



I/O RACK

---

**Rio3224-D2**

**Rio1608-D2**

## **Owner's Manual**

Keep This Manual For Future Reference.

AUDIO INTERFACE

EN

# Contents

## **PRECAUTIONS..... 5**

## **Introduction 7**

Features .....	7
Firmware Updates.....	7
Precautions for Rack Mounting .....	8
Recessed Installation .....	8

## **About Dante 8**

Caution when using a network switch.....	8
--	---

## **Controls and Functions 9**

Front Panel .....	9
Rear Panel.....	11

## **Display Operations 12**

Operation Flow.....	12
Menu structure .....	12
Selecting menu items.....	12
About the parameter display .....	12
Selecting ports.....	13
About port names.....	13
METER menu .....	14
GAIN menu .....	15
+48V ON menu .....	15
HPF ON menu .....	16
HPF F menu .....	16
GC (Gain Compensation) ON menu .....	17
About the status indication .....	17
SETUP menu .....	18
Status bar .....	20
INFORMATION menu .....	21
Support for Dante Domain Manager (DDM) (V1.10 or later) .....	22
Other functions.....	24

## **About Connections 25**

Daisy Chain Network .....	25
Star Network.....	25
Dante Network Settings and Audio Routing .....	26

## **Head Amp Control 26**

Control from a Supported Device.....	26
Head Amplifier Parameters That Can be Monitored and Controlled .....	26

## **Troubleshooting 27**

Troubleshooting .....	27
Messages .....	28

## **Specifications 31**

General Specifications .....	31
Analog Input Characteristics.....	32
Analog Output Characteristics.....	32
Digital I/O Characteristics .....	32
Digital Output Characteristics .....	32
Dimensions .....	33

### **Accessories**

#### **(Please check the package contents.)**

- Owner's Manual
- AC power cord
- Dante Virtual Soundcard Token leaflet

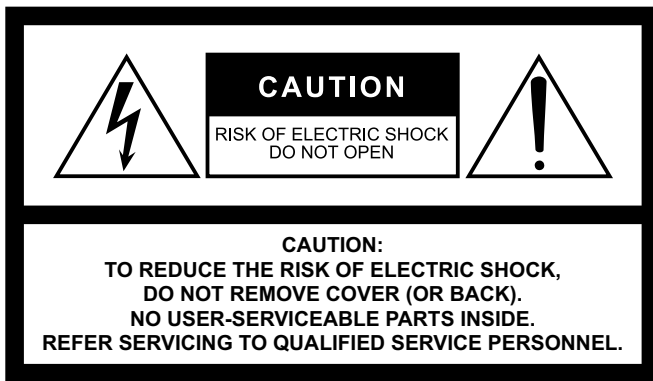

The above warning is located on the rear of the unit.



L'avertissement ci-dessus est situé sur l'arrière de l'unité.

## Explanation of Graphical Symbols Explication des symboles



The lightning flash with arrowhead symbol within an equilateral triangle is intended to alert the user to the presence of uninsulated "dangerous voltage" within the product's enclosure that may be of sufficient magnitude to constitute a risk of electric shock to persons.  
L'éclair avec une flèche à l'intérieur d'un triangle équilatéral est destiné à attirer l'attention de l'utilisateur sur la présence d'une « tension dangereuse » non isolée à l'intérieur de l'appareil, pouvant être suffisamment élevée pour constituer un risque d'électrocution.



The exclamation point within an equilateral triangle is intended to alert the user to the presence of important operating and maintenance (servicing) instructions in the literature accompanying the product.  
Le point d'exclamation à l'intérieur d'un triangle équilatéral est destiné à attirer l'attention de l'utilisateur sur la présence d'instructions importantes sur l'emploi ou la maintenance (réparation) de l'appareil dans la documentation fournie.

## IMPORTANT SAFETY INSTRUCTIONS

- 1 Read these instructions.
- 2 Keep these instructions.
- 3 Heed all warnings.
- 4 Follow all instructions.
- 5 Do not use this apparatus near water.
- 6 Clean only with dry cloth.
- 7 Do not block any ventilation openings. Install in accordance with the manufacturer's instructions.
- 8 Do not install near any heat sources such as radiators, heat registers, stoves, or other apparatus (including amplifiers) that produce heat.
- 9 Do not defeat the safety purpose of the polarized or grounding-type plug. A polarized plug has two blades with one wider than the other. A grounding type plug has two blades and a third grounding prong. The wide blade or the third prong are provided for your safety. If the provided plug does not fit into your outlet, consult an electrician for replacement of the obsolete outlet.
- 10 Protect the power cord from being walked on or pinched particularly at plugs, convenience receptacles, and the point where they exit from the apparatus.
- 11 Only use attachments/accessories specified by the manufacturer.
- 12 Use only with the cart, stand, tripod, bracket, or table specified by the manufacturer, or sold with the apparatus. When a cart is used, use caution when moving the cart/apparatus combination to avoid injury from tip-over.
- 13 Unplug this apparatus during lightning storms or when unused for long periods of time.
- 14 Refer all servicing to qualified service personnel. Servicing is required when the apparatus has been damaged in any way, such as power-supply cord or plug is damaged, liquid has been spilled or objects have fallen into the apparatus, the apparatus has been exposed to rain or moisture, does not operate normally, or has been dropped.



### WARNING

TO REDUCE THE RISK OF FIRE OR ELECTRIC SHOCK, DO NOT EXPOSE THIS APPARATUS TO RAIN OR MOISTURE.

(UL60065\_03)

## PRÉCAUTIONS CONCERNANT LA SÉCURITÉ

- 1 Lire ces instructions.
- 2 Conserver ces instructions.
- 3 Tenir compte de tous les avertissements.
- 4 Suivre toutes les instructions.
- 5 Ne pas utiliser ce produit à proximité d'eau.
- 6 Nettoyer uniquement avec un chiffon propre et sec.
- 7 Ne pas bloquer les orifices de ventilation. Installer l'appareil conformément aux instructions du fabricant.
- 8 Ne pas installer l'appareil à proximité d'une source de chaleur comme un radiateur, une bouche de chaleur, un poêle ou tout autre appareil (y compris un amplificateur) produisant de la chaleur.
- 9 Ne pas modifier le système de sécurité de la fiche polarisée ou de la fiche de terre. Une fiche polarisée dispose de deux broches dont une est plus large que l'autre. Une fiche de terre dispose de deux broches et d'une troisième pour le raccordement à la terre. Cette broche plus large ou cette troisième broche est destinée à assurer la sécurité de l'utilisateur. Si la fiche équipant l'appareil n'est pas compatible avec les prises de courant disponibles, faire remplacer les prises par un électricien.
- 10 Acheminer les cordons d'alimentation de sorte qu'ils ne soient pas piétinés ni coincés, en faisant tout spécialement attention aux fiches, prises de courant et au point de sortie de l'appareil.
- 11 Utiliser exclusivement les fixations et accessoires spécifiés par le fabricant.
- 12 Utiliser exclusivement le chariot, le stand, le trépied, le support ou la table recommandés par le fabricant ou vendus avec cet appareil. Si l'appareil est posé sur un chariot, déplacer le chariot avec précaution pour éviter tout risque de chute et de blessure.
- 13 Débrancher l'appareil en cas d'orage ou lorsqu'il doit rester hors service pendant une période prolongée.
- 14 Confier toute réparation à un personnel qualifié. Faire réparer l'appareil s'il a subi tout dommage, par exemple si la fiche ou le cordon d'alimentation est endommagé, si du liquide a coulé ou si des objets sont tombés à l'intérieur de l'appareil, si l'appareil a été exposé à la pluie ou à de l'humidité, si l'appareil ne fonctionne pas normalement ou est tombé.



### AVERTISSEMENT

POUR RÉDUIRE LES RISQUES D'INCENDIE OU DE DÉCHARGE ÉLECTRIQUE, N'EXPOSEZ PAS CET APPAREIL À LA PLUIE OU À L'HUMIDITÉ.

(UL60065\_03)

## FCC INFORMATION (U.S.A.)

### 1. IMPORTANT NOTICE: DO NOT MODIFY THIS UNIT!

This product, when installed as indicated in the instructions contained in this manual, meets FCC requirements. Modifications not expressly approved by Yamaha may void your authority, granted by the FCC, to use the product.

### 2. IMPORTANT:

When connecting this product to accessories and/or another product use only high quality shielded cables. Cable/s supplied with this product MUST be used. Follow all installation instructions. Failure to follow instructions could void your FCC authorization to use this product in the USA.

### 3. NOTE:

This product has been tested and found to comply with the requirements listed in FCC Regulations, Part 15 for Class "B" digital devices. Compliance with these requirements provides a reasonable level of assurance that your use of this product in a residential environment will not result in harmful interference with other electronic devices. This equipment generates/uses radio frequencies and, if not installed and used according to the instructions found in the users manual, may cause interference harmful to the operation of other electronic devices. Compliance with FCC regulations does

not guarantee that interference will not occur in all installations. If this product is found to be the source of interference, which can be determined by turning the unit "OFF" and "ON", please try to eliminate the problem by using one of the following measures:

Relocate either this product or the device that is being affected by the interference.

Utilize power outlets that are on different branch (circuit breaker or fuse) circuits or install AC line filter/s.

In the case of radio or TV interference, relocate/reorient the antenna. If the antenna lead-in is 300 ohm ribbon lead, change the lead-in to co-axial type cable.

If these corrective measures do not produce satisfactory results, please contact the local retailer authorized to distribute this type of product. If you can not locate the appropriate retailer, please contact Yamaha Corporation of America, Electronic Service Division, 6600 Orangethorpe Ave, Buena Park, CA90620

The above statements apply ONLY to those products distributed by Yamaha Corporation of America or its subsidiaries.

\* This applies only to products distributed by YAMAHA CORPORATION OF AMERICA.

(class B)

### COMPLIANCE INFORMATION STATEMENT (DECLARATION OF CONFORMITY PROCEDURE)

Responsible Party : Yamaha Corporation of America  
Address : 6600 Orangethorpe Ave., Buena Park, Calif. 90620  
Telephone : 714-522-9011  
Type of Equipment : AUDIO INTERFACE  
Model Name : Rio3224-D2/Rio1608-D2

This device complies with Part 15 of the FCC Rules.  
Operation is subject to the following two conditions:  
1) this device may not cause harmful interference, and  
2) this device must accept any interference received including interference that may cause undesired operation.  
See user manual instructions if interference to radio reception is suspected.

\* This applies only to products distributed by  
YAMAHA CORPORATION OF AMERICA.

(FCC DoC)

# PRECAUTIONS

## PLEASE READ CAREFULLY BEFORE PROCEEDING

Please keep this manual in a safe place for future reference.



### **WARNING**

**Always follow the basic precautions listed below to avoid the possibility of serious injury or even death from electrical shock, short-circuiting, damages, fire or other hazards. These precautions include, but are not limited to, the following:**

#### **Power supply/power cord**

- Do not place the power cord near heat sources such as heaters or radiators, and do not excessively bend or otherwise damage the cord, place heavy objects on it, or place it in a position where anyone could walk on, trip over, or roll anything over it.
- Only use the voltage specified as correct for the device. The required voltage is printed on the name plate of the device.
- Use only the supplied power cord/plug.  
If you intend to use the device in an area other than in the one you purchased, the included power cord may not be compatible. Please check with your Yamaha dealer.
- Check the electric plug periodically and remove any dirt or dust which may have accumulated on it.
- Be sure to insert the power plug completely. Otherwise, electrical shock or fire might be caused.
- When setting up the device, make sure that the AC outlet you are using is easily accessible. If some trouble or malfunction occurs, immediately turn off the power switch and disconnect the plug from the outlet. Even when the power switch is turned off, as long as the power cord is not unplugged from the wall AC outlet, the device will not be disconnected from the power source.
- Remove the electric plug from the outlet when the device is not to be used for extended periods of time, or during electrical storms.
- Be sure to connect to an appropriate outlet with a protective grounding connection. Improper grounding can result in electrical shock, fire, or damage.



#### **Shock hazard**

##### **Disconnect all power sources.**

This device receives power from multi sources. When setting up the device, make sure that the AC outlet you are using is easily accessible. If some trouble or malfunction occurs, immediately turn off the power switch and disconnect the all plugs from the outlet. Even when the power switch is turned off, as long as the power cord is not unplugged from the wall AC outlet, the device will not be disconnected from the power source.

#### **Do not open**

- This device contains no user-serviceable parts. Do not open the device or attempt to disassemble the internal parts or modify them in any way. If it should appear to be malfunctioning, discontinue use immediately and have it inspected by qualified Yamaha service personnel.

#### **Water warning**

- Do not expose the device to rain, use it near water or in damp or wet conditions, or place on it any containers (such as vases, bottles or glasses) containing liquids which might spill into any openings. If any liquid such as water seeps into the device, turn off the power immediately and unplug the power cord from the AC outlet. Then have the device inspected by qualified Yamaha service personnel.
- Never insert or remove an electric plug with wet hands.

#### **Hearing loss**

- Before connecting the device to other devices, turn off the power for all devices. Also, before turning the power of all devices on or off, make sure that all volume levels are set to the minimum. Failing to do so may result in hearing loss, electric shock, or device damage.
- When turning on the AC power in your audio system, always turn on the power amplifier LAST, to avoid hearing loss and speaker damage. When turning the power off, the power amplifier should be turned off FIRST for the same reason.

#### **Fire warning**

- Do not place any burning items or open flames near the device, since they may cause a fire.

#### **If you notice any abnormality**

- If any of the following problems occur, immediately turn off the power switch and disconnect the electric plug from the outlet.
  - The power cord or plug becomes frayed or damaged.
  - Unusual smells or smoke are emitted.
  - Some object has been dropped into the device.
  - There is a sudden loss of sound during use of the device.
  - Cracks or other visible damage appear on the device.Then have the device inspected or repaired by qualified Yamaha service personnel.
- If this device should be dropped or damaged, immediately turn off the power switch, disconnect the electric plug from the outlet, and have the device inspected by qualified Yamaha service personnel.



### **CAUTION**

**Always follow the basic precautions listed below to avoid the possibility of physical injury to you or others, or damage to the device or other property. These precautions include, but are not limited to, the following:**

#### **Power supply/power cord**

- When removing the electric plug from the device or an outlet, always hold the plug itself and not the cord. Pulling by the cord can damage it.

#### **Location**

- Do not place the device in an unstable position where it might accidentally fall over and cause injuries.
- Do not block the vents. This device has ventilation holes at the rear to prevent the internal temperature from becoming too high. In particular, do not place the device on its side or upside down. Inadequate ventilation can result in overheating, possibly causing damage to the device(s), or even fire.
- Do not place the device in a location where it may come into contact with corrosive gases or salt air. Doing so may result in malfunction.

- Before moving the device, remove all connected cables.
- If the device is mounted in an EIA standard rack, carefully read the section “Precautions for Rack Mounting” on page 8. Inadequate ventilation can result in overheating, possibly causing damage to the device(s), malfunction, or even fire.

## Maintenance

- Remove the power plug from the AC outlet when cleaning the device.

## Handling caution

- Do not insert your fingers or hands in any gaps or openings on the device (vents, etc.).
- Avoid inserting or dropping foreign objects (paper, plastic, metal, etc.) into any gaps or openings on the device (vents, etc.) If this happens, immediately turn off the power, unplug the power cord from the AC outlet, and have the device inspected by qualified Yamaha service personnel.
- Do not rest your weight on the device or place heavy objects on it. Avoid applying excessive force to the buttons, switches or connectors to prevent injuries.
- Avoid pulling the connected cables to prevent injuries or damage to the device.

Yamaha cannot be held responsible for damage caused by improper use or modifications to the device, or data that is lost or destroyed.

## NOTICE

**To avoid the possibility of malfunction/ damage to the product, damage to data, or damage to other property, follow the notices below.**

### Handling and maintenance

- Do not use the device in the vicinity of a TV, radio, AV equipment, mobile phone, or other electric devices. Otherwise, the device, TV, or radio may generate noise.
- Do not expose the device to excessive dust or vibration, or extreme cold or heat (such as in direct sunlight, near a heater, or in a car during the day), in order to prevent the possibility of panel disfiguration, unstable operation, or damage to the internal components.
- Do not place vinyl, plastic or rubber objects on the device, since this might discolor the panel.
- When cleaning the device, use a dry and soft cloth. Do not use paint thinners, solvents, cleaning fluids, or chemical-impregnated wiping cloths.
- Condensation can occur in the device due to rapid, drastic changes in ambient temperature—when the device is moved from one location to another, or air conditioning is turned on or off, for example. Using the device while condensation is present can cause damage. If there is reason to believe that condensation might have occurred, leave the device for several hours without turning on the power until the condensation has completely dried out.
- Always turn the power off when the device is not in use.

### Connectors

XLR-type connectors are wired as follows (IEC60268 standard): pin 1: ground, pin 2: hot (+), and pin 3: cold (-).

## Information

### About copyrights

\* Copying of the commercially available musical data including but not limited to MIDI data and/or audio data is strictly prohibited except for your personal use.

### About this manual

\* The illustrations and LCD screens as shown in this manual are for instructional purposes only.

\* The company names and product names in this manual are the trademarks or registered trademarks of their respective companies.

### About the organic EL display

\* Organic EL displays are created using extremely sophisticated technology. For this reason, there might be a very small number of picture elements that remain unlit or constantly lit. Also, you might notice line-shaped irregularities in color or brightness, or changes in color. Such things are due to the structure of an organic EL display, and are not malfunctions. Thank you for your understanding.

### About disposal

This product contains recyclable components. When disposing of this product, please contact the appropriate local authorities.

### European models

Purchaser/User Information specified in EN55103-2:2009.

Conforms to Environments: E1, E2, E3 and E4

### Information for Users on Collection and Disposal of Old Equipment



This symbol on the products, packaging, and/or accompanying documents means that used electrical and electronic products should not be mixed with general household waste.

For proper treatment, recovery and recycling of old products, please take them to applicable collection points, in accordance with your national legislation and the Directives 2002/96/EC.

By disposing of these products correctly, you will help to save valuable resources and prevent any potential negative effects on human health and the environment which could otherwise arise from inappropriate waste handling.

For more information about collection and recycling of old products, please contact your local municipality, your waste disposal service or the point of sale where you purchased the items.

#### [For business users in the European Union]

If you wish to discard electrical and electronic equipment, please contact your dealer or supplier for further information.

#### [Information on Disposal in other Countries outside the European Union]

This symbol is only valid in the European Union. If you wish to discard these items, please contact your local authorities or dealer and ask for the correct method of disposal.

(weee\_eu)

The model number, serial number, power requirements, etc., may be found on or near the name plate, which is at the rear of the unit. You should note this serial number in the space provided below and retain this manual as a permanent record of your purchase to aid identification in the event of theft.

**Model No.**

**Serial No.**

(rear\_en\_01)

# Introduction

Thank you for choosing the Yamaha Rio3224-D2/Rio1608-D2 I/O Rack. This product is a Dante-compatible I/O rack for use in a mixing system. The Rio3224-D2 is an I/O rack featuring 32 channels of analog input, 16 channels of analog output, and 8 channels of AES/EBU output. The Rio1608-D2 is an I/O rack featuring 16 channels of analog input and 8 channels of analog output. This manual explains the settings and troubleshooting that a mixing engineer or operator will perform when setting up or preparing the mixing system. In order to take full advantage of this product's functionality, be sure to read this owner's manual before use. After reading the manual, keep it for future reference.

## NOTE

- Where specifications for the Rio3224-D2 differ from the Rio1608-D2, this manual places specifications that apply only to the Rio1608-D2 in curly brackets { } (e.g., [INPUT connectors 1-32 {1-16}]).
- Unless otherwise noted, illustrations for the Rio3224-D2 are used.
- If certain specifications are common to both the Rio3224-D2 and Rio1608-D2, both units are collectively called "Rio-D2."
- The RIVAGE PM, CL, and QL series devices can control the head amplifiers over communication protocols which allow for redundant connections. These devices are called "supported digital mixers" in this manual. On the other hand, the TF series, Nuage, MTX, and R Remote devices can control the head amplifiers over communication protocols which do not allow for redundant connections. Not only these devices but also "supported digital mixers" are collectively called "supported devices" in this manual.

## Features

### Long-distance Dante Network Capability

Low-latency, low-jitter audio can be transferred over distances up to 100 meters\* between devices via standard Ethernet cables using the Dante network protocol. The Rio-D2 can be used as a general-purpose I/O box for the Dante network. Supported sampling rates are 44.1 kHz, 48 kHz, 88.2 kHz, and 96 kHz.

This unit supports the AES67 standard for audio networking interoperability, and allows audio connections via AES67 with various compatible audio networks.

\* Maximum practical distance may vary according to the cable used.

### Display and Encoder for Improved Visibility and Operability

The front panel features an organic EL display, an encoder with switch, and buttons. The internal head amps and parameters such as HPF can be viewed and controlled using only the Rio-D2 unit itself. The unit's internal errors and status are clearly indicated in the display.

### Remotely Controllable Internal Head Amplifiers

Internal head amp parameters can be remotely controlled from the supported devices.

### Digital Outputs (Rio3224-D2 only)

The Rio3224-D2 features XLR-3-32 type balanced connectors for AES/EBU format digital audio outputs.

### Gain Compensation Function

If the Gain Compensation function of the Rio-D2 is enabled from a supported device (such as a RIVAGE PM, CL, or QL series) or R Remote, the subsequent fluctuations in analog gain will be compensated for by the internal digital gain of the Rio-D2, and the audio signal will be output to the Dante network at the gain level that was fixed immediately before the Gain Compensation function was enabled. This means that, for example, if the same inputs are shared by FOH and monitor, changing the FOH gain will not affect the monitor mix balance.

### Two Internal Power Supply Units

Duplicate power supplies allow continued operation even in the unlikely event that one power supply experiences a problem.

### Quietness

Noise-reduction measures for the fans provide greater silence.

## Firmware Updates

This product enables you to update the unit firmware to improve operations, add functions, and correct possible malfunctions. The following two types of firmware are available for the unit.

- Unit's firmware
- Dante module firmware

Details on updating the firmware are available on the following website:

<http://www.yamahaproaudio.com/>

For information on updating and setting up the unit, please refer to the firmware update guide available on the website.

## NOTE

When you update Dante firmware on the unit, be sure to update Dante firmware on other Dante-compatible devices connected to the Rio-D2.

## Precautions for Rack Mounting

This unit is rated for operation at ambient temperatures ranging from 0 to 40 degrees Celsius. When mounting the unit with other Rio-D2 unit(s) or other device(s) in an EIA standard equipment rack, internal temperatures can exceed the specified upper limit, resulting in impaired performance or failure. When rack mounting the unit, always observe the following requirements to avoid heat buildup:

- If three or more Rio-D2 units are mounted without space in the same rack, set the fan speeds to HIGH.
- If multiple units are mounted in the same rack with their fan speeds set to LOW, leave a 1U rack space between every two units. Also either leave the open spaces uncovered or install appropriate ventilating panels to minimize the possibility of heat buildup.
- When mounting the unit in a rack with devices such as power amplifiers that generate a significant amount of heat, leave more than 1U of space between the Rio-D2 and other equipment. Also either leave the open spaces uncovered or install appropriate ventilating panels to minimize the possibility of heat buildup.
- To ensure sufficient airflow, leave the rear of the rack open and position it at least 10 centimeters from walls or other surfaces. If the rear of the rack can't be left open, install a commercially available fan or similar ventilating option to secure sufficient airflow. If you've installed a fan kit, there may be cases in which closing the rear of the rack will produce a greater cooling effect. Refer to the rack and/or fan unit manual for details.

## Recessed Installation

If you want to recess the front panel surface of the device from the front edge of the rack, you can adjust the position of the rack mount brackets to recess the device by 50mm or 100mm, as shown in the illustration below.

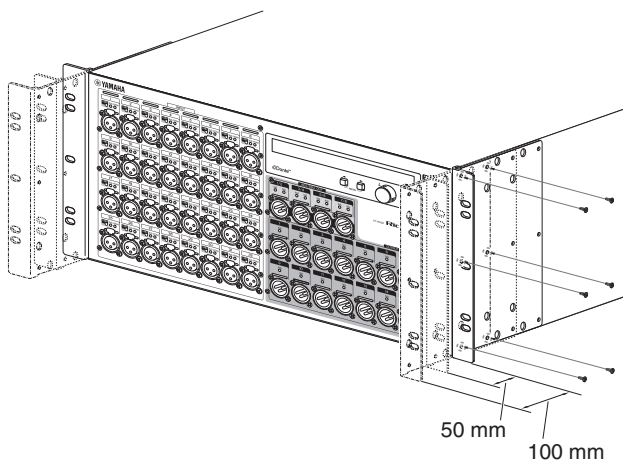

In the same way, rack mount hardware can also be attached to the rear panel surface.

### NOTE

When you install the brackets, use the same screws that you just removed.

## About Dante

Dante is a network audio protocol developed by the Audinate. Within a Giga-bit Ethernet (GbE), Dante delivers multi-channel audio signals at various sampling frequencies and bit rates, as well as device control signals.

Visit the Audinate website for more details on Dante.

<http://www.audinate.com/>

More information on Dante is also posted on the Yamaha Pro Audio website:

<http://www.yamahaproaudio.com/>

This product uses Dante Brooklyn2.

Refer to the Audinate website (English) for details on the open-source licenses for the particular software.

<https://www.audinate.com/software-licensing>

## Caution when using a network switch

Please do not use the EEE function (\*) of network switches in a Dante network.

Although power management should be negotiated automatically in switches that support EEE, some switches do not perform the negotiation properly.

This may cause EEE to be enabled in Dante networks when it is not appropriate, resulting in poor synchronization performance and occasional dropouts.

Therefore we strongly recommend the following:

- When using a managed switch, turn off the EEE function of all ports used by Dante. Do not use a switch that is unable to turn off the EEE function.
- If using an unmanaged switch, do not use a switch that supports the EEE function. Such switches are unable to turn off the EEE function.

\* EEE (Energy Efficient Ethernet) is a technology that reduces switch power consumption during periods of low network traffic. It is also known as Green Ethernet or IEEE802.3az.



# Controls and Functions

## Front Panel

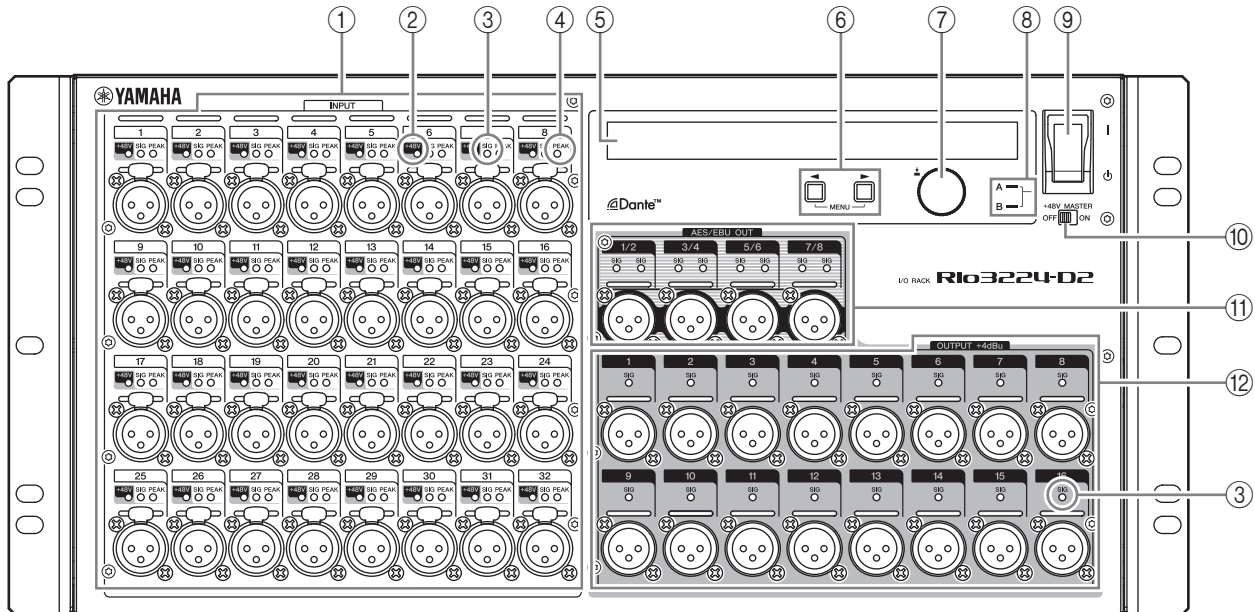

### ① [INPUT] Connectors 1–32 {1–16}

These are the XLR-3-31 type analog balanced connectors for the input channels. The input level range is from  $-62$  dBu to  $+10$  dBu.  $+48$ V phantom power can be supplied to devices that require it via the input connectors.

### ② [+48V] Indicators

These indicators light when  $+48$ V phantom power is turned ON for the corresponding input channels. On/off switching is controlled from this unit's front panel display, or from a compatible digital mixer. No phantom power will be supplied, however, if the [+48V MASTER] switch is OFF, even if phantom power to individual channels is turned ON (the  $+48$ V indicators will flash). If a serious error occurs in this unit, the indicators of all channels will light or flash.



### CAUTION:

- If phantom power is not required, you must turn OFF the  $+48$ V MASTER switch or the phantom power setting.
- When turning phantom power ON, make sure that no equipment other than phantom-powered devices such as condenser microphones are connected to the corresponding [INPUT] connectors. Applying phantom power to a device that does not require phantom power can damage the connected device.
- Do not connect or disconnect a device to an INPUT while phantom power is applied. Doing so can damage the connected device and/or the unit itself.
- To prevent possible damage to speakers, make sure that power amplifiers and/or powered speakers are turned OFF when switching phantom power ON or OFF. We also recommend setting all digital mixing console output controls to minimum when turning phantom power ON or OFF. Sudden high level peaks caused by the switching operation can damage equipment as well as the hearing of those present.

### ③ [SIG] (Signal) Indicators

These indicators light green when the signal applied to the corresponding channel reaches or exceeds  $-40$  dBFS.

If a serious error occurs in this unit, the indicators of all channels will light or flash.

### ④ [PEAK] Indicators

These indicators light red when the signal level of the corresponding channel reaches or exceeds  $-3$  dBFS.

If a serious error occurs in this unit, the indicators of all channels will light or flash.

### ⑤ Display

This shows information such as the parameter values of each port's head amp, or error and status indications.

### ⑥ ◀ (DEC) button / ▶ (INC) button

Use these to move the cursor within the display.

### ⑦ Encoder with switch

By turning this you can edit a parameter value shown in the display. By pressing the encoder you can select or confirm a setting, or switch the display.

### ⑧ Power Indicator

Lights when AC power to the unit is ON.

### ⑨ Power Switch (⏻)

Turns power to the unit ON or OFF.



#### **CAUTION:**

Even when the power switch is turned off, electricity is still flowing to the product at the minimum level. When you are not using the product for a long time, make sure to unplug the power cord from the wall AC outlet.

#### **NOTE**

Rapidly turning the unit on and off in succession can cause it to malfunction. After turning the unit off, wait for about 6 seconds before turning it on again.

### ⑩ [+48V MASTER] Switch

This is the master switch for the unit's +48V phantom power supply.

If the [+48V MASTER] switch is off, no phantom power will be supplied to the unit's input connectors even if the individual input phantom power settings are ON. In this case, the [+48V] indicators will flash on channels for which phantom power is turned ON.

### ⑪ [AES/EBU OUT] Connectors 1/2–7/8 (Rio3224-D2 only)

These XLR-3-32 type balanced connectors deliver AES/EBU format digital output from the unit's corresponding output channels. Each connector outputs 2-channel digital audio.

### ⑫ [OUTPUT +4 dBu] Connectors 1–16 {1–8}

These XLR-3-32 type balanced connectors deliver analog output from the unit's corresponding output channels. Nominal output level is +4 dBu.

#### **NOTICE:**

If you cannot avoid connecting this unit's balanced output to an unbalanced device, you should match the ground polarity of each unit, since differences in the ground polarity may cause a device to malfunction.

For the cable used to connect an unbalanced device, connect pin 3 COLD with pin 1 GND.

## Rear Panel

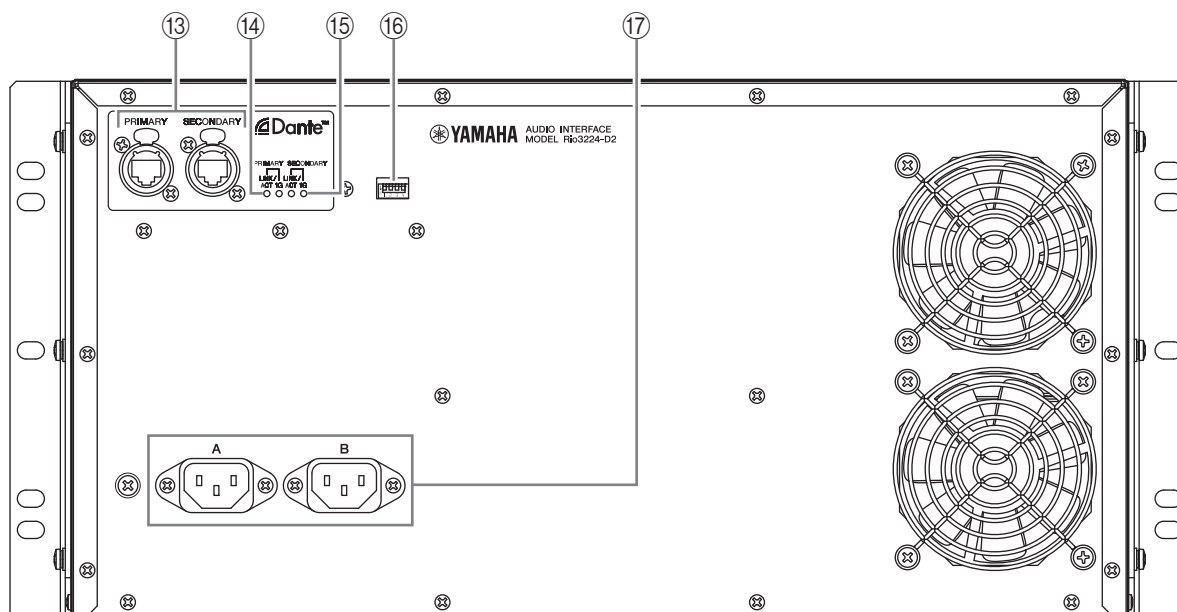

### 13 [PRIMARY]/[SECONDARY] Connectors

These etherCON (RJ45) ports can be connected to other Dante devices such as a RIVAGE PM, CL, QL, or TF series unit using Ethernet cables (CAT5e or better recommended).

If the SETUP menu SECONDARY PORT parameter is set to DAISY CHAIN in the display, the signal that is input from one port is transmitted to the other port. Refer to “Daisy Chain Network” in the “About Connections” section (see page 25) for more information on daisy chain connections.

If the SETUP menu SECONDARY PORT parameter is set to REDUNDANT in the display, the [PRIMARY] port is for the primary connection and the [SECONDARY] port is for the secondary (backup) connection. If the unit is unable to transmit signals through the [PRIMARY] connector for some reason (e.g., due to damage or accidental removal of the cable, or a failed network switch), the [SECONDARY] connector will automatically take over the connection. Refer to “About Redundant Networks” in the “About Connections” section (see page 25) for more information on redundant networks.

#### NOTE

- The use of Ethernet cables with Neutrik etherCON CAT5e compatible RJ45 plugs is recommended. Standard RJ45 plugs can also be used.
- Use STP (shielded twisted pair) cable to prevent electromagnetic interference. Make sure that the metal parts of the plugs are electrically connected to the STP cable shield by conductive tape or comparable means.
- Connect only Dante-compatible devices or GbE-compatible devices (including a computer).

### 14 [LINK/ACT] Indicators

These indicators show the communication status of the [PRIMARY] and [SECONDARY] connectors. They flash fast if the Ethernet cables are connected properly.

### 15 [1G] Indicators

These indicators light when the Dante network is functioning as Giga-bit Ethernet.

### 16 DIP switches

These are for expanding the functionality in the future. At present, no functions are assigned to these DIP switches.

### 17 AC IN Connector

Connect the supplied AC power cord here. First, connect the power cord to the device, then insert the power cord plug into the AC outlet.

The supplied power cord features a special latching mechanism (V-LOCK) to prevent the power cord from being accidentally disconnected. Connect the power cord by inserting the power cord fully until it is locked.



#### CAUTION:

Be sure to turn the power off before connecting or disconnecting the power cord. Press the latch button on the plug to disconnect the power cord.

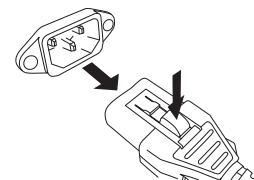

# Display Operations

## Operation Flow

On the Rio-D2, you can use the front panel display, ◀ (DEC) button, ▶ (INC) button, and the encoder with switch to set the various parameters that are shown in each menu.

- The menu name is shown at the left edge of the display.
- The parameters of each menu are shown in the center of the display.
- The status of the unit is shown by icons at the right edge of the display.

## Menu structure

The menu shown at the left edge of the display has the following structure. Select a menu item by pressing the ◀ (DEC) button and ▶ (INC) button appropriately.

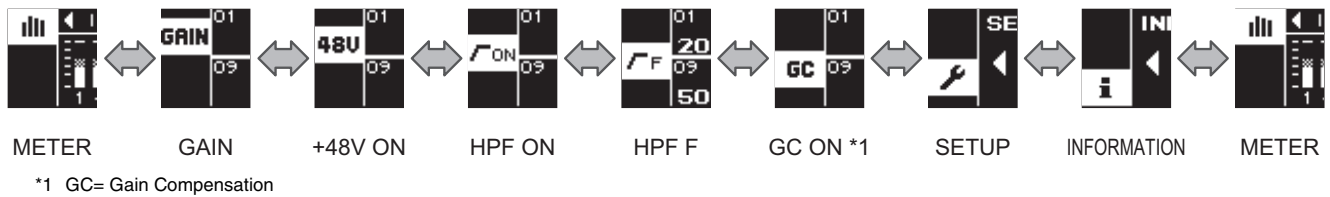

## Selecting menu items

You can use any of the following methods to select the next-lower menu.

- Press the ◀ (DEC) button and ▶ (INC) button simultaneously.
- While holding down the ◀ (DEC) button for 1.5 seconds or longer, press the ▶ (INC) button.

You can use any of the following methods to select the next-higher menu.

- Hold down the ◀ (DEC) button and ▶ (INC) button simultaneously for 1.5 seconds or longer.
- While holding down the ▶ (INC) button for 1.5 seconds or longer, press the ◀ (DEC) button.

## About the parameter display

The parameter values of each port are shown divided into three areas (upper line, middle line, lower line).

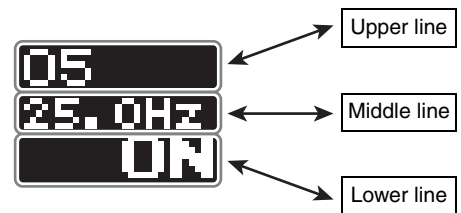

For the HPF ON menu

## Selecting ports

### For the METER menu

You can select ports by pressing the ◀ (DEC) button or ▶ (INC) button. When you do so, the selected port's LEDs (+48V/SIG/PEAK for Input, or SIG for Output) is lit for one second. The corresponding location is indicated by a white frame cursor. The white frame cursor disappears when 10 seconds have elapsed without any front panel operation being performed. When you once again press the ◀ (DEC) button or ▶ (INC) button, the white frame cursor appears at the previous port position.

By long-pressing the ◀ (DEC) button or ▶ (INC) button, you can jump to the first of every eight ports.

### For the GAIN, +48V ON, HPF ON, HPF F, and GC ON menus

You can select the input port or status by pressing the ◀ (DEC) button or ▶ (INC) button. Output ports cannot be selected. The parameter display area of the selected input port is highlighted; at the same time, the selected input port's LEDs (+48V/SIG/PEAK) are lit for one second. The highlighted indication disappears when 10 seconds have elapsed without any front panel operation being performed. When you once again press the ◀ (DEC) button or ▶ (INC) button, the white frame cursor appears at the previous port position.

By long-pressing the ◀ (DEC) button or ▶ (INC) button, you can jump to the first of every eight ports.

## About port names

### For the METER menu

The port name shown in the upper middle of the display can be edited from Dante Controller. A name of up to 31 characters can be specified for each input or output port.

### For the GAIN, +48V ON, HPF ON, HPF F, and GC ON menus

The port name shown in the upper line can be edited from Dante Controller. A name of up to 31 characters can be specified for each input or output port. However, since a maximum of five characters of the port name can be shown in this menu, “..” is shown following the fourth character if six or more characters have been specified.

## METER menu

Level meters for all input ports are shown at the left, and level meters for all output ports are shown at the right. The upper part of the display shows icons that indicate the +48V ON, HPF ON, and GC ON status of the selected port.



Rio3224-D2



Rio1608-D2

### Viewing the meters

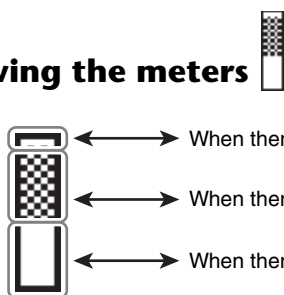

When there is an input or output of  $-3$  dBFS or greater

When there is an input or output greater than  $-18$  dBFS and not exceeding  $-3$  dBFS

When there is an input or output greater than  $-60$  dBFS and not exceeding  $-18$  dBFS

**NOTE**

PEAK HOLD is always on, but you can clear the PEAK held for each port by pressing the encoder switch.

### Head amp (HA) gain value settings

By turning the encoder with switch, you can adjust the HA gain value of the selected port. This can be adjusted in the range of  $-6$  dB to  $+66$  dB, in 1 dB units.

## GAIN menu

This shows the HA parameters of all input ports (upper line: port name, middle line: GC ON status and compensation gain value, lower line: HA gain value), the port name of all output ports, and the status of the unit itself. In this menu you can set the HA gain value of each input port.

<b>GAIN</b>	01	02	03	04	05	06	07	08	17	18	19	20	21	22	23	24
	-6	-5	-4	gc -3 -3	-2	gc -1 -1	gc 0 0	gc +1 +1	+20	+21	+22	gc +23 +23	+24	gc +25 +25	gc +26 +26	gc +27 +27
	09	10	11	gc +13 +13	+14	gc +15 +15	gc +16 +16	gc +17 +17	+59	+60	+61	gc +62 +62	+63	gc +64 +64	gc +65 +65	gc +66 +66

Rio3224-D2 input ports

<b>GAIN</b>	01	02	03	04	05	06	07	08	Y002-Yamaha-Rio3224-D2-123abc							
	09	10	11	12	13	14	15	16	17	18	19	20	21	22	23	24

Rio3224-D2 output ports/status (upper right)

<b>GAIN</b>	01	02	03	04	05	06	07	08	Y002-Yamaha-Rio1608-D2-123abc							
	-6	-5	-4	gc -3 -3	-2	gc -1 -1	gc 0 0	gc +1 +1	DANTE AUDIO RESOURCE OVERFLOW!							
	09	10	11	gc +13 +13	+14	gc +15 +15	gc +16 +16	gc +17 +17	01	02	03	04	05	06	07	08

Rio1608-D2 input ports (left half) / output ports (lower right) / status (upper right)

## Head amp (HA) gain value settings

By turning the encoder with switch, you can adjust the HA gain value of the selected port. This can be adjusted in the range of -6 dB to +66 dB, in 1 dB units.

## +48V ON menu

This shows the +48V parameters of all input ports (upper line: port name, lower line: +48V ON), the port name of all output ports, and the status of the unit itself. In this menu, you can turn on/off the phantom power (+48V) of each input port.

<b>48V</b>	01	02	03	04	05	06	07	08	17	18	19	20	21	22	23	24
	ON	OFF	ON	ON	ON	ON	ON	ON	ON	ON	ON	ON	ON	ON	ON	ON
	09	10	11	12	13	14	15	16	25	26	27	28	29	30	31	32
	ON	ON	ON	ON	ON	ON	ON	ON	ON	ON	ON	ON	ON	ON	ON	ON

Rio3224-D2 input ports

<b>48V</b>	01	02	03	04	05	06	07	08	Y002-Yamaha-Rio3224-D2-123abc							
	09	10	11	12	13	14	15	16	17	18	19	20	21	22	23	24

Rio3224-D2 output ports/status (upper right)

<b>48V</b>	01	02	03	04	05	06	07	08	Y002-Yamaha-Rio1608-D2-123abc							
	ON	OFF	ON	ON	ON	ON	ON	ON	DANTE AUDIO RESOURCE OVERFLOW!							
	09	10	11	12	13	14	15	16	01	02	03	04	05	06	07	08
	ON	ON	ON	ON	ON	ON	ON	ON								

Rio1608-D2 input ports (left half) / output ports (lower right) / status (upper right)

## Phantom power (+48V) settings

By turning the encoder with switch, you can turn on/off the phantom power (+48V) of the selected port. If the value is changed, the display area of the currently selected parameter flashes. When you press the encoder, the setting is actually specified, and the flashing stops. If you move the cursor while the parameter display area is flashing, the change is discarded and the flashing also stops. In the same way, if you switch the menu selection while the parameter display area is flashing, the change is discarded.

## HPF ON menu

This shows the HPF parameters of all input ports (upper line: port name, middle line: HPF cutoff frequency, lower line: HPF ON status), the port name of all output ports, and the status of the unit itself. In this menu you can set the HPF on/off status of each input port.

01	02	03	04	05	06	07	08	17	18	19	20	21	22	23	24		
ON		22.4Hz	ON	25.0Hz	ON	28.0Hz	ON	30.0Hz	ON	100Hz	ON	112Hz	ON	125Hz	ON	132Hz	ON
09	10	11	12	13	14	15	16	25	26	27	28	29	30	31	32		
		56.0Hz	ON	63.0Hz	ON	71.0Hz	ON	75.0Hz	ON	450Hz	ON	500Hz	ON	560Hz	ON	600Hz	ON

Rio3224-D2 input ports

01	02	03	04	05	06	07	08	Y002-Yamaha-Rio3224-D2-123abc							
ON								17	18	19	20	21	22	23	24

Rio3224-D2 output ports/status (upper right)

01	02	03	04	05	06	07	08	Y002-Yamaha-Rio1608-D2-123abc							
ON		22.4Hz	ON	25.0Hz	ON	28.0Hz	ON	30.0Hz	ON	DANTE AUDIO RESOURCE OVERFLOW!					
09	10	11	12	13	14	15	16	01	02	03	04	05	06	07	08
		56.0Hz	ON	63.0Hz	ON	71.0Hz	ON	75.0Hz	ON						

Rio1608-D2 input ports (left half) / output ports (lower right) / status (upper right)

## HPF on/off settings

By turning the encoder with switch, you can turn on/off the HPF of the selected port. If the value is changed, the display area of the currently selected parameter flashes. When you press the encoder, the setting is actually specified, and the flashing stops. If you move the cursor while the parameter display area is flashing, the change is discarded and the flashing also stops. In the same way, if you switch the menu selection while the parameter display area is flashing, the change is discarded.

## HPF F menu

This shows the HPF parameters of all input ports (upper line: port name, middle line: HPF ON status, lower line: HPF cutoff frequency), the port name of all output ports, and the status of the unit itself. In this menu you can set the HPF cutoff frequency of each input port.

01	02	03	04	05	06	07	08	17	18	19	20	21	22	23	24		
F		20.0	21.2	22.4	23.6	25.0	26.5	28.0	30.0	90.0	95.0	100	106	112	118	125	132
09	10	11	12	13	14	15	16	25	26	27	28	29	30	31	32		
		50.0	53.0	56.0	60.0	63.0	67.0	71.0	75.0	400	425	450	475	500	530	560	600

Rio3224-D2 input ports

01	02	03	04	05	06	07	08	Y002-Yamaha-Rio3224-D2-123abc							
F								17	18	19	20	21	22	23	24

Rio3224-D2 output ports/status (upper right)

01	02	03	04	05	06	07	08	Y002-Yamaha-Rio1608-D2-123abc							
F		20.0	21.2	22.4	23.6	25.0	26.5	28.0	30.0	DANTE AUDIO RESOURCE OVERFLOW!					
09	10	11	12	13	14	15	16	01	02	03	04	05	06	07	08
		50.0	53.0	56.0	60.0	63.0	67.0	71.0	75.0						

Rio1608-D2 input ports (left half) / output ports (lower right) / status (upper right)

## HPF cutoff frequency settings

By turning the encoder with switch, you can change the HPF cutoff frequency of the selected port in the range of 20.0 Hz to 600.0 Hz.



## GC (Gain Compensation) ON menu

This shows the GC parameters of all input ports (upper line: port name, middle line: compensation gain value if GC is ON; HA gain value if GC is OFF, lower line: GC ON status), the port name of all output ports, and the status of the unit itself. In this menu you can set the GC on/off status of each input port.

	01	02	03 -4dB OFF	04 -3dB ON	05	06 -1dB ON	07 0dB ON	08 +1dB ON	17	18	19	20 +23dB ON	21	22 +25dB ON	23 +26dB ON	24 +27dB ON
GC	09	10	11	12 +13dB ON	13	14 +15dB ON	15 +16dB ON	16 +17dB ON	25	26	27	28 +62dB ON	29	30 +64dB ON	31 +65dB ON	32 +66dB ON

Rio3224-D2 input ports

	01	02	03	04	05	06	07	08	Y002-Yamaha-Rio3224-D2-123abc							
GC	09	10	11	12	13	14	15	16	17	18	19	20	21	22	23	24

Rio3224-D2 output ports/status (upper right)

	01	02	03 -4dB OFF	04 -3dB ON	05	06 -1dB ON	07 0dB ON	08 +1dB ON	Y002-Yamaha-Rio1608-D2-123abc							
GC	09	10	11	12 +13dB ON	13	14 +15dB ON	15 +16dB ON	16 +17dB ON	01	02	03	04	05	06	07	08

Rio1608-D2 input ports (left half) / output ports (lower right) / status (upper right)

### GC on/off settings

By turning the encoder with switch, you can turn on/off the GC of the selected port. If the value is changed, the display area of the currently selected parameter flashes. When you press the encoder, the setting is actually specified, and the flashing stops. If you move the cursor while the parameter display area is flashing, the change is discarded and the flashing also stops. In the same way, if you switch the menu selection while the parameter display area is flashing, the change is discarded.

### About the status indication

The upper line of the status area shown in each menu shows the Dante device label of the unit; the lower line shows an ERROR/INFORMATION icon and corresponding message only if an ERROR/INFORMATION state occurs.

	01	02	03	04	05	06	07	08	Y002-Yamaha-Rio3224-D2-123abc								
GC	09	10	11	12	13	14	15	16	17	18	19	20	21	22	23	24	⚠️

Rio3224-D2 output ports/status (upper right)

	01	02	03	04 -3dB ON	05	06 -1dB ON	07 0dB ON	08 +1dB ON	Y002-Yamaha-Rio1608-D2-123abc								
GC	09	10	11	12 +13dB ON	13	14 +15dB ON	15 +16dB ON	16 +17dB ON	01	02	03	04	05	06	07	08	⚠️

Rio1608-D2 input ports (left half) / output ports (lower right) / status (upper right)

#### NOTE

If multiple ERROR/INFORMATION states occur, the highest-priority state is shown.

The device label can be specified from Dante Controller. Assign the device label as follows.

- Do not change the first five characters of "Y0##-" (## is the UNIT ID). Even if you try to change them, they are forcibly corrected back to "Y0##-".
- A maximum of 31 characters total

When you move the cursor to the status indication and press the encoder with switch, the unit's version, SYSTEM/SYNC message ID, and ERROR state (SYSTEM/SYNC message) are shown as depicted in the following illustration. Press the encoder once again to return to the menu screen. For a list of the SYSTEM/SYNC messages, refer to the "Troubleshooting" section's table "SYSTEM/SYNC Messages" (page 29).

NAME: Y002-Yamaha-Rio3224-D2-123abc	SYSTEM: NORMAL	✕
MODEL: V1.00	SYNC: E01-03	
FPGA: V1.00	ERROR: WRONG WORD CLOCK!	
DANTE: 3.10.2.2 4.0.3.5 1.3.4		

## SETUP menu

This shows the current values for various setup parameters of this unit.



### Selecting a setup item

You can select setup items by pressing the ◀ (DEC) button or ▶ (INC) button. The parameter value of the selected item is highlighted. The highlighted indication disappears when 10 seconds have elapsed without any front panel operation being performed. You can switch screens by long-pressing the ◀ (DEC) button or ▶ (INC) button.

### Setting a parameter value

By turning the encoder with switch, you can select the parameter value of the selected item. If the value is changed, the display area of the currently selected parameter flashes. When you press the encoder, the setting is actually specified, and the flashing stops. If you move the cursor while the parameter display area is flashing, the change is discarded and the flashing also stops. In the same way, if you switch the menu selection while the parameter display area is flashing, the change is discarded.

### Table of parameters

The following table shows the items that can be selected, the description of the parameters, and the values that can be specified (\* is the default value).

Item/parameter	Description	Values												
UNIT ID	Specifies the ID of the unit.	Y000(0)–Y07F(127) Y001*												
START UP MODE	<p>Selects the HA parameter settings at start-up. This setting is applied the next time the unit starts up.</p> <p>If you plan to control the HA parameters from a supported digital mixer such as the RIVAGE PM, CL, or QL series product, set the switches to [REFRESH]. The input and output audio of the Rio-D2 will be muted until the connected supported mixer transmits its settings to the Rio-D2, in order to prevent accidental audio output from the Rio-D2.</p> <p>REFRESH: Initializes a portion of the internal memory when starting up. Also, the input and output audio is muted until the HA parameter settings from a supported digital mixer is completed.</p> <table border="1" style="margin-left: 20px;"> <tr><td>HA GAIN</td><td>–6 dB</td></tr> <tr><td>+48V</td><td>OFF</td></tr> <tr><td>HPF</td><td>OFF</td></tr> <tr><td>HPF FREQ</td><td>80.0 Hz</td></tr> <tr><td>GAIN COMPENSATION</td><td>OFF</td></tr> <tr><td>COMPENSATION GAIN</td><td>–6 dB</td></tr> </table> <p>RESUME: Starts up in the state prior to the most recent power-off. The input and output audio is not muted.</p> <p>REFRESH w/o MUTE Initializes a portion of the internal memory when starting up. The initial values are the same as for REFRESH. However, the input and output audio is not muted.</p>	HA GAIN	–6 dB	+48V	OFF	HPF	OFF	HPF FREQ	80.0 Hz	GAIN COMPENSATION	OFF	COMPENSATION GAIN	–6 dB	REFRESH*, RESUME, REFRESH w/o MUTE
HA GAIN	–6 dB													
+48V	OFF													
HPF	OFF													
HPF FREQ	80.0 Hz													
GAIN COMPENSATION	OFF													
COMPENSATION GAIN	–6 dB													

Item/parameter	Description	Values
SECONDARY PORT	Specifies the operating mode of the Dante secondary port.	DAISY CHAIN*, REDUNDANT
FAN SPEED	Specifies the rotation speed of the fan.	LOW*, HIGH
NETWORK MODE	Selects the IP address setting mode. This IP address is used when remotely controlling the unit from a computer, or when updating the firmware. This is different than the IP address for Dante.	AUTO*, STATIC IP
IP ADDRESS	Specifies the IP address. (when STATIC IP is specified)	0.0.0.0 In the case of AUTO, the current value is shown*
SUBNET MASK	Specifies the SUBNET MASK. (when STATIC IP is specified)	0.0.0.0 In the case of AUTO, the current value is shown*
DEFAULT GW	Specifies the DEFAULT GATEWAY. (when STATIC IP is specified)	0.0.0.0 In the case of AUTO, the current value is shown*
DIMMER	Specifies the time after which the organic EL display goes dark when the unit has not been operated for a time. In order to extend the life of the organic EL display, it is designed to go dark after the specified time.	10sec, 30sec, 1min, 2min, 3min*, 5min
ERROR MESSAGES	Specifies whether an error message is shown without dimming the display when an error/alert occurs.	LIGHT OFF*, KEEP MESSAGES
BRIGHTNESS	Specifies the brightness of the organic EL display. This can also be adjusted by long-pressing the ◀ (DEC) button and ▶ (INC) button for 1.5 seconds or longer, and turning the encoder with switch.	5%–100% (adjustable in 5% steps), 70%*
INITIALIZE	When you select the memory that you want to initialize, and then press the encoder with switch, a confirmation appears; press [OK] to execute initialization.	FACTORY PRESET*, HA PARAMETERS, DANTE SETTINGS

IP ADDRESS, SUBNET MASK, and DEFAULT GW can be edited only if NETWORK MODE is set to STATIC IP. If it is set to AUTO, the current settings can only be displayed, and not edited.

If Dante Device Lock has been enabled from Dante Controller, it is not possible to change the Dante-related settings UNIT ID or SECONDARY PORT. If you want to change these settings, use Dante Controller to defeat Dante Device Lock.

## Status bar

The status bar at the right edge of the display shows icons to indicate the status of the Rio-D2 unit.



### Icon

Six types of icons are shown.



ERROR



INFORMATION



MUTE



DAISY CHAIN



PANEL LOCK



HA READ ONLY

The displayed position depends on the icon.

<b>Upper line</b>	Shows the ERROR icon  or the INFORMATION icon . If both ERROR and INFORMATION have occurred, the ERROR icon takes priority and is shown. If neither ERROR nor INFORMATION has occurred, nothing is displayed. If ERROR or INFORMATION have occurred, the content is shown in the second line of the status display area within each HA screen. For an explanation of the content, refer to “Messages” (page 28).
<b>Middle line</b>	Shows the MUTE icon  if muted (all ports together). If the SECONDARY PORT parameter is set to DAISY CHAIN, the DAISY CHAIN icon  is shown. If muted (all ports together) and in addition the SECONDARY PORT parameter is set to DAISY CHAIN, the MUTE icon takes priority and is shown. If mute is cleared (all ports together) and in addition the SECONDARY PORT parameter is set to REDUNDANT, nothing is displayed.
<b>Lower line</b>	Shows the LOCK status. If panel lock is enabled, the PANEL LOCK icon  is shown. If HA Read Only is specified, the HA READ ONLY icon  is shown to indicate read-only. If panel lock is enabled and HA Read Only is specified, the PANEL LOCK icon  takes priority and is shown. If panel lock is not enabled, or if HA Read Only is not specified, nothing is displayed.

### About HA Read Only

This function allows the HA parameters to be changed only from a supported digital mixer such as a RIVAGE PM, CL or QL series device. When the HA Read Only is ON, it will not be possible to turn off the settings of the HA parameters or HA Read Only from this device.

Also, this function is set when this device synchronizes with a supported digital mixer, or when this device is operated after the synchronization. Once HA Read Only is turned to ON, even if the connection between this device and the supported digital mixer is interrupted, the HA Read Only setting is maintained until this device is restarted.

#### NOTE

The settings in the SETUP menu of this device can be changed even when HA Read Only is ON.

In order to turn HA Read Only OFF, you must perform an operation from the supported digital mixer, or power-cycle this unit.

# INFORMATION menu

This shows various information about this unit.



When the INFORMATION menu is selected

## Selecting items and viewing detailed information

You can select items by pressing the ◀ (DEC) button or ▶ (INC) button. The highlighted indication disappears when 10 seconds have elapsed without any front panel operation being performed.

When you press the encoder with switch, detailed information for the selected item is shown. By turning the encoder, you can scroll the displayed content up or down.

## List of items

The viewable items are as follows.

Item	Description
SYSTEM	Shows the version of this unit, the SYSTEM/SYNC status, and the ERROR occurrence status.
DANTE	Shows information for Dante-related settings. (For display only)
LOG	Shows the event/error history of this unit.
REPORT	Shows basic information and historical information for this unit.

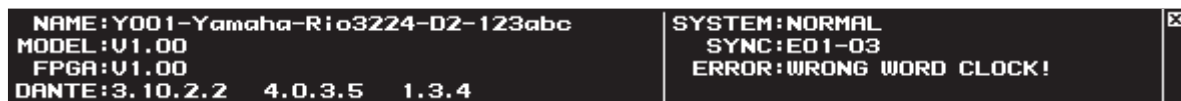

SYSTEM information display example



DANTE information display example

- \*) DEVICE LABEL, SAMPLE RATE, ENCODING, LATENCY or PREFERRED LEADER can be set only from Dante Controller.
- \*) If this unit's Dante Device Lock is enabled, or if AES67 mode is enabled, the respective icon is shown in the upper right.

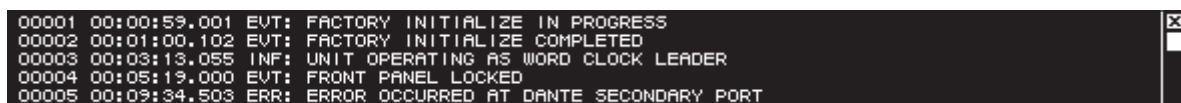

LOG information display example

- \*) By turning the encoder, you can scroll the displayed content up or down.



REPORT information display example

- \*) By turning the encoder, you can scroll the displayed content up or down.

## Support for Dante Domain Manager (DDM) (V1.10 or later)

### NOTE

Firmware V1.10 or later is required for Rio-D2 to enroll a domain with DDM.

### INFORMATION – DANTE screen

#### ■ When enrolling a domain:

The DDM indicator appears at the top right side of the DANTE screen.

The R/W indicator or the R/O indicator also appears, depending on the LOCAL CONTROLLER ACCESS setting for the DDM server.

\* LOCAL CONTROLLER ACCESS = Read Write

DEVICE LABEL: Y001-Yamaha-Rio3224-D2-123abc		DDM	R/W	✕
SAMPLE RATE: 96.0kHz, NONE	ENCODING: 24bit	LATENCY: 1.00ms	PREFERRED LEADER: OFF	SECONDARY PORT: SWITCHED
			LINK SPEED: PRI 1G, SEC -	

\* LOCAL CONTROLLER ACCESS = Read Only

DEVICE LABEL: Y001-Yamaha-Rio3224-D2-123abc		DDM	R/O	✕
SAMPLE RATE: 96.0kHz, NONE	ENCODING: 24bit	LATENCY: 1.00ms	PREFERRED LEADER: OFF	SECONDARY PORT: SWITCHED
			LINK SPEED: PRI 1G, SEC -	

When the local access is set to “Read Only,” changing the Dante settings (UNIT ID, SECONDARY PORT) on the Rio-D2 unit will result in the following pop-up message.



When a DDM domain is enrolled, unregistering the domain will result in the DISC indicator appearing at the top right side of the screen. In addition, when a DDM domain is enrolled without connecting to the DDM server, the DISC indicator also appears.

DEVICE LABEL: Y001-Yamaha-Rio3224-D2-123abc		DDM	DISC	✕
SAMPLE RATE: 96.0kHz, NONE	ENCODING: 24bit	LATENCY: 1.00ms	PREFERRED LEADER: OFF	SECONDARY PORT: SWITCHED
			LINK SPEED: PRI 1G, SEC -	

## INFORMATION – REPORT screen

### ■ Enrolling a domain

```
DDM_CONNECT_STATE = CONNECTED
DDM_DOMAIN_KIND = DOMAIN
DDM_DOMAIN_UUID = 00-FD-FD-FD-FD-AB-AB-AB-AB-AB-AB-AB-AB-FE-EE-FE
DDM_LOCAL_ACCESS = READ_ONLY
DDM_REMOTE_ACCESS = NONE
```

\* Local Access = Read Only, Remote Access = None

### ■ No DDM server

```
DDM_CONNECT_STATE = DISCONNECTED
DDM_DOMAIN_KIND = DOMAIN
DDM_DOMAIN_UUID = 00-FD-FD-FD-FD-AB-AB-AB-AB-AB-AB-AB-AB-FE-EE-FE
DDM_LOCAL_ACCESS = READ_ONLY
DDM_REMOTE_ACCESS = NONE
```

#### ① DDM\_CONNECT\_STATE

Displays the connection status to the DDM server in the network.

- CONNECTED: The unit has been connected to the DDM server in the network.
- DISCONNECTED: There is no DDM server in the network.

#### ② DDM\_DOMAIN\_KIND

Displays the enrolling status for the DDM domain.

- DOMAIN: DDM domain is enrolled
- UNMANAGED: DDM domain is not enrolled

#### ③ DDM\_DOMAIN\_UUID

Displays the UUID of an applicable domain when enrolling the DDM domain.

When the unit has not enrolled a domain, FF-FF-FF-FF-FF-FF-FF-FF-FF-FF-FF-FF-FF-FF-FF-FF is displayed.

#### ④ DDM\_LOCAL\_ACCESS

Displays the accessing status of the Dante setup (including the DANTE PATCH settings) of the unit.

- READ\_WRITE: Editing is available
- READ\_ONLY: Editing is disabled

#### ⑤ DDM\_REMOTE\_ACCESS

Displays the status of Dante setup accessing the external Dante device.

- OPERATOR: Editing is available  
(however, operating from the Rio-D2 unit is not available)
- GUEST: Reading is available, editing is disabled
- NONE: Reading and editing are disabled

## Other functions

### Initializing to the factory-set state

If you turn on the power while holding down both the ◀ (DEC) button and ▶ (INC) button, you can enter a mode that returns this unit's settings to their factory-set state. This is the same as if you use the SETUP menu to select INITIALIZE → FACTORY PRESET.

### Initializing the HA parameters

If you turn on the power while holding down only the ◀ (DEC) button, you will enter a mode that returns the HA parameter values to their factory-set state.

This is the same as if you use the SETUP menu to select INITIALIZE → HA PARAMETERS.

### Initializing the Dante parameters

If you turn on the power while holding down only the ▶ (INC) button, you will enter a mode that returns the Dante parameter values to their factory-set state. This is the same as if you use the SETUP menu to select INITIALIZE → DANTE SETTINGS.

### Factory-set initial values

The following table shows the factory-set initial values.

	Parameter	Initial value
SETUP	UNIT ID	Y001
	START UP MODE	REFRESH
	SECONDARY PORT	DAISY CHAIN
	FAN SPEED	LOW
	NETWORK MODE	AUTO
	IP ADDRESS	(determined by DHCP or link local)
	SUBNET MASK	(determined by DHCP or link local)
	DEFAULT GW	(determined by DHCP or link local)
	DIMMER	3 min
	ERROR MESSAGE	LIGHT OFF
	BRIGHTNESS	70%
HA Parameters	HA GAIN	-6 dB
	+48V	Off
	HPF	Off, 80.0 Hz
	GAIN COMPENSATION	Off, -6 dB
DANTE Settings	Sample Rate	96 kHz (follower), Pull-up/down = None *1
	Latency	1.0 ms
	Encoding	PCM 24 bit
	Dante Redundancy	Switched (depends on the setting of SETUP → SECONDARY PORT)
	IP Address	Auto
	Device Label	Y001-Yamaha-Rio3224-D2-nnnnnn *2 Y001-Yamaha-Rio1608-D2-nnnnnn *2
	Channel Label	<channel number>
	AES67 Mode	Disabled
	Device Lock	Unlock

\*1 The default setting of the Sample Rate is 96 kHz. Please be careful when using Rio-D2 in combination with devices which do not support 96 kHz (such as CL or QL series).

\*2 nnnnnn is the lowest six digits of the Dante Primary MAC Address.

### Panel lock

While this unit is operating, you can put it in the panel lock state by simultaneously holding down the ◀ (DEC) button, ▶ (INC) button, and the encoder with switch for approximately three seconds. This state is maintained even if the unit is power-cycled. To defeat the panel lock state, simultaneously hold down the ◀ (DEC) button, ▶ (INC) button, and the encoder with switch once again for approximately three seconds.

### Brightness adjustment

While this unit is operating, simultaneously hold down the ◀ (DEC) button and ▶ (INC) button for at least 1.5 seconds, and turn the encoder with switch to adjust the brightness of the display (BRIGHTNESS).



# About Connections

There are two ways to connect the Rio-D2 to a Dante network.

**NOTE**

A daisy chain connection is suitable for a simple system with a small number of devices. Use a star network if a large number of devices are connected.

## Daisy Chain Network

A daisy chain is a wiring scheme in which multiple devices are connected together in sequence. In this way, networking is simple and requires no network switches.

If you connect a large number of devices, you must set a higher latency value to avoid skipping audio that could be caused by an increased delay in signal transfer among the devices. Also, if a connection is broken in a daisy chain network, the signal flow is interrupted at that point and no signal will be transferred beyond that point.

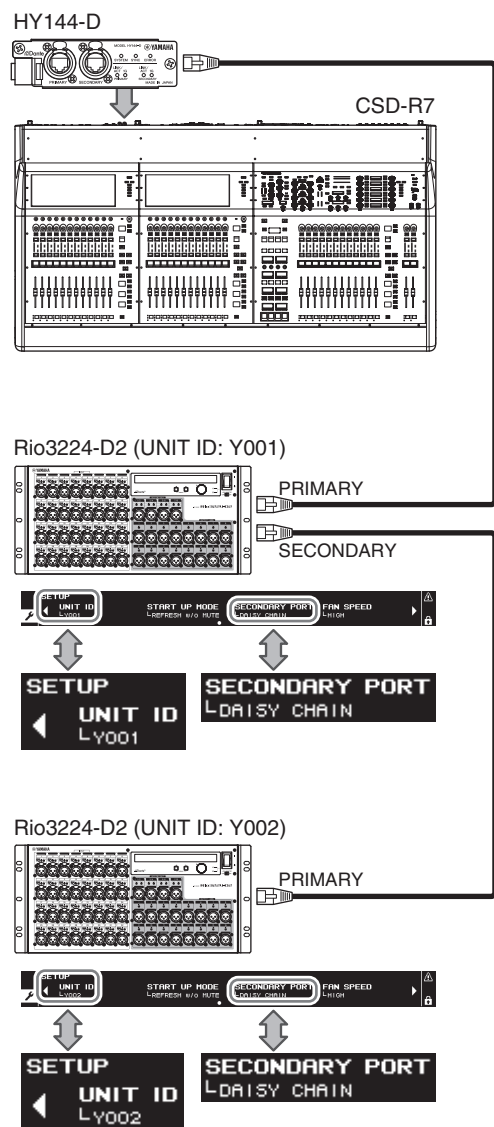

## Star Network

In a star network, each device is connected to a central network switch. Using a GbE-compatible network switch enables you to configure a wide-band, large-scale network. We recommend a network switch that features various functions to control and monitor the network (such as Qos, the ability to assign priority to data flows - e.g., clock synchronization or audio transmission on certain data circuits.)

With this topology, it is common to configure a redundant network so that an unexpected network problem will not affect any audio or otherwise stable communications.

## About Redundant Networks

A redundant network consists of two circuits, a primary circuit and a secondary circuit. Normally, the network operates on the primary circuit. However, if the primary connection is broken, the secondary circuit will automatically take over communications. Therefore, using a redundant network with a star topology would increase communication stability relative to a daisy chain network.

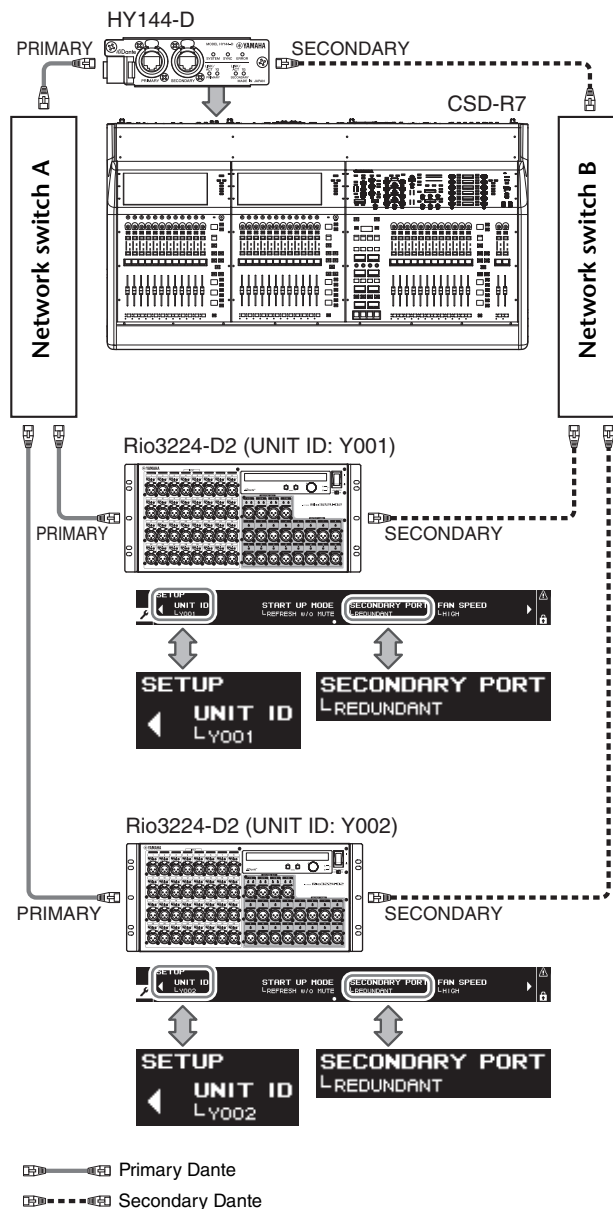

## Dante Network Settings and Audio Routing

Rio-D2 does not have the function for changing Dante network settings, such as Sample Rate, Latency or Encoding. The Dante network settings will be controlled from Dante Controller or the supported digital mixers.

For details on the Dante network settings, refer to the corresponding owner's manual of the supported digital mixers.

The audio inputs and outputs of multiple Dante devices can be freely routed within a Dante network. This means that you need to make settings that specify the destination to which each channel's signal will be sent.

Use Dante Controller to specify the Dante network and audio routing settings.

Dante Controller can be downloaded from the following website.

<http://www.yamahaproaudio.com/>

For details on Dante Controller, refer to the Dante Controller owner's manual on the same website.

## Head Amp Control

The Rio-D2 head amplifiers can be remotely controlled from a host device, such as a compatible Yamaha digital mixing console.

### Control from a Supported Device

The Rio-D2 head amplifiers can be controlled remotely from a supported device such as a RIVAGE PM, CL, QL, or TF series device.

The supported device connected to Rio-D2 displays the model name and UNIT ID number of the corresponding Rio-D2 unit to be controlled.

If you plan to connect to a supported device to monitor and control the head amplifiers, refer to the owner's manual for the corresponding device.

### Head Amplifier Parameters That Can be Monitored and Controlled

Parameter	Description
+48V	Turns +48V phantom power ON or OFF for each channel.
HA GAIN	Adjusts gain from -6 dB to 66 dB in 1-dB increments.
HPF	Turns the high-pass filter ON or OFF.
HPF FREQ	Adjusts the cutoff frequency of the high-pass filter (12 dB/Oct.) from 20 Hz to 600 Hz in 60 steps.
METER	Displays a level meter for each input channel.
+48V Master SW	Displays the [+48V MASTER] switch ON/OFF status of the +48V phantom power supply.
Gain Compensation	Turns the Gain Compensation ON or OFF.

# Troubleshooting

## Troubleshooting

Symptom	Cause	Possible Solution
The power won't turn on. The power indicator doesn't light.	The power cable is connected improperly.	Connect the power cable properly (see page 11).
	The [POWER] switch is not turned ON.	Turn the [POWER] switch ON. If the power still will not come on, refer the problem to your Yamaha dealer.
The unit is not receiving an input signal.	The input cables are not connected properly.	Connect the cables properly.
	The source device is not delivering an appropriate signal.	Output a signal from the source device and make sure that the SIG indicators on the appropriate channels will light.
	The internal head amplifier gain is not set to an appropriate level.	Set the internal head amplifier gain to an appropriate level.
	The SETUP menu's START UP MODE setting is REFRESH, but the supported digital mixer has not started up.	Start the supported digital mixer to send the setting to the Rio-D2.
The input level is too low.	A condenser microphone is connected.	Turn the [+48V MASTER] switch ON. Turn phantom power for the corresponding channel(s) ON.
	The internal head amplifier gain is not set to an appropriate level.	Set the internal head amplifier gain to an appropriate level.
	No sound is heard.	The cables are not connected properly.
No sound is heard.	The SETUP menu's START UP MODE setting is REFRESH, but the supported digital mixer has not started up.	Start the supported digital mixer to send the setting to the Rio-D2.
	Output is muted.	Unmute the output on the supported digital mixer.
	The Dante settings of the Rio-D2 do not match with those of the supported devices.	If you are using a supported digital mixer, set the CONSOLE ID to #1 on the digital mixer to be synchronized. For other devices, match the settings in Dante Controller.
	The head amp cannot be controlled.	The Rio-D2 has not been mounted on the RACK of the supported digital mixer.
Adjusting the internal head amp gain does not change the audio level.	The Gain Compensation function is turned on.	If you are not using the Gain Compensation function, turn it off.
The Rio-D2 cannot be found in Dante Controller.	An incorrect value is assigned to the IP address for Dante.	Initialize the Rio-D2.
The Rio-D2 cannot be found in R Remote.	The UNIT ID setting conflicts with another R series unit.	Set each UNIT ID uniquely.
The Rio-D2 cannot be found in R Remote.	The IP address setting is incorrect. Alternatively, the network is connected wrongly.	Re-check the network settings. Check whether they are set to the same subnet. If the SECONDARY PORT parameter is set to REDUNDANT, check whether the unit is connected to the [PRIMARY] port.
The power LED is lit, but nothing appears in the display.	A malfunction may have occurred.	Contact a Yamaha service center.
Button operations and encoder operations do not work.	Panel lock is enabled.	Defeat panel lock. To defeat panel lock, simultaneously hold down the ◀ (DEC) button, ▶ (INC) button, and the encoder with switch for approximately three seconds.

The Yamaha Pro Audio site provides a FAQ (frequently asked questions and answers).

<http://www.yamahaproaudio.com/>

## Messages

The front panel display of the Rio-D2 shows various messages such as errors, alerts, warnings, information, and confirmations.

### Error Messages

Message	Description	Possible Solution
SYSTEM DOWN - PLEASE CONTACT YAMAHA SERVICE	A system error was detected at the previous execution.	Contact a Yamaha service center.
DANTE MODULE ERROR	A problem was detected in the Dante module.	Restart this unit.
ILLEGAL MAC ADDRESS - PLEASE CONTACT YAMAYA SERVICE	There is no valid Mac Address.	Contact a Yamaha service center.
FAN HAS MALFUNCTIONED - PLEASE CONTACT YAMAHA SERVICE	The fan is not working correctly.	
MEMORY ERROR	Failed to read from non-volatile memory.	Information that was saved during the previous operation was lost, so this information must be reset.

### Alert Messages

Message	Description	Possible Solution
FIRMWARE VERSION MISMATCH - BETWEEN YAMAHA AND DANTE. PLEASE UPDATE FIRMWARE.	The combination of this unit's firmware and the Dante firmware is incorrect.	Match them to compatible versions.
FIRMWARE VERSION MISMATCH - BETWEEN DEVICE AND CONSOLE. PLEASE UPDATE FIRMWARE.	The combination of the Rio-D2's firmware and the console's firmware is incorrect.	
POWER SUPPLY "A" ("B") FAILED - IF A RECURRING ERROR, PLEASE CONTACT YAMAHA SERVICE	The supply of power to either power supply A or B has been interrupted.	Check that the power supply cable is connected. If checking does not resolve the problem, contact a Yamaha service center.
GIGABIT NETWORK LINK FAILED - SWITCHED TO 100Mbps (or 10Mbps)	Dante is not operating at 1 Gbps.	Check the link status. Try plugging into a different network switch or a different port. Alternatively, try using a different network cable.
DANTE PRIMARY NETWORK LOST - SWITCHED TO SECONDARY PORT	When connected via a redundant network, a problem occurred with the primary connection, and communication has switched to the secondary connection.	Check the connections of the Dante primary network.

### Warning Messages

Message	Description	Possible Solution
DANTE AUDIO RESOURCE OVERFLOW	The number of Dante flows has exceeded the limit.	Re-configure the Dante audio routing, for example by eliminating unneeded routings, or by using multicast rather than unicast to improve the efficiency.
WRONG WORD CLOCK	A problem was detected in the word clock.	Check the Word Clock setting.
DANTE PORTS HAVE NO NETWORK CONNECTION	Nothing is connected to the Dante port.	Check the Dante connection.
DANTE CONNECTION ERROR	A problem was detected in the Dante connection.	
ERROR OCCURRED AT DANTE SECONDARY PORT	The Dante secondary port is not functioning.	
DANTE DEVICE LOCK ENABLED	You may have attempted to change a Dante setting such as this unit's UNIT ID or SECONDARY PORT while Dante Device Lock was enabled.	Use Dante Controller to defeat Dante Device Lock.

## Information Messages

Message	Description
FACTORY INITIALIZE IN PROGRESS	Started initializing to the factory-set state.
FACTORY INITIALIZE COMPLETED	Finished initializing to the factory-set state.
HA MEMORY INITIALIZE IN PROGRESS	Started initializing the HA parameters.
HA MEMORY INITIALIZE COMPLETED	Finished initializing the HA parameters.
DANTE INITIALIZE IN PROGRESS	Started initializing the Dante settings.
DANTE INITIALIZE COMPLETED	Finished initializing the Dante settings.
FRONT PANEL LOCKED	Started panel lock.
FRONT PANEL LOCKED. TO UNLOCK - PRESS ALL BUTTONS FOR 3 SECONDS	Panel lock is enabled.
FRONT PANEL UNLOCKED	Panel lock was disabled.

## Confirmation Messages

Message	Description
ARE YOU SURE YOU WANT TO INITIALIZE? - FACTORY PRESET -	Start initializing to the factory-set state?
ARE YOU SURE YOU WANT TO INITIALIZE? - HA PARAMETERS -	Start initializing the HA parameters?
ARE YOU SURE YOU WANT TO INITIALIZE? - DANTE SETTINGS -	Start initializing the Dante settings?

## SYSTEM Messages

Message	ID *	Description	Possible Solution
NORMAL		Starting up normally	---
DANTE MODULE ERROR!	E00-03	An error has occurred in the Dante module.	The device has malfunctioned; please contact a Yamaha service center.
ILLEGAL MAC ADDRESS!	E00-04	Because the MAC Address setting has been damaged, communication is not possible.	
UNIT FAN HAS MALFUNCTIONED!	E00-06	The cooling fan has stopped.	Check whether a foreign object might be caught in the fan. If this does not solve the problem, contact a Yamaha service center.
MEMORY ERROR!	E00-07	Because the internal memory has been lost, all data was initialized.	If you are using the unit with the START UP MODE parameter set to RESUME, and power-cycling the unit does not solve the problem, please contact a Yamaha service center.
VERSION MISMATCH!	E00-10	The combination of this unit's firmware and the Dante firmware is incorrect. The combination of this unit's firmware and the supported digital mixer's firmware is incorrect.	Match them to compatible versions.
DANTE AUDIO RESOURCE OVERFLOW!	E00-11	The number of Dante flows has exceeded the limit.	Re-configure the Dante audio routing, for example by eliminating unneeded routings, or by using multicast rather than unicast to improve the efficiency.
POWER SUPPLY FAILED!	E00-13	The supply of power to either power supply A or B has been interrupted.	Check that the power supply cable is connected. If checking does not resolve the problem, contact a Yamaha service center.

\* If the ID is blank, the message is shown. Otherwise, the ID is shown.

## SYNC Messages

Message	ID *	Description	Possible Solution
NORMAL		Operating normally	---
SYNCHRONIZATION		Currently processing synchronization within the Dante network.	Wait until startup or synchronization is completed. It may take up to 45 seconds for this to be completed.
WRONG WORD CLOCK!	E01-03	The word clock setting is incorrect.	On the supported digital mixer or in Dante Controller, set the clock leader and the sampling frequency correctly.
DANTE PORT DOES NOT HAVE CONNECTION!	E01-04	The Dante network is not connected.	Check whether an Ethernet cable might be disconnected or broken.
DANTE CONNECTION ERROR!	E01-05	Other Dante devices cannot be found because the Dante network connections are incorrect.	Check whether the Ethernet cable connections are correct.
DANTE IS NOT WORKING BY GIGA BIT!	E01-06	A device that does not support gigabit Ethernet is connected.	If you are conveying audio via Dante, use devices that support gigabit Ethernet.
DANTE IS WORKING AT SECONDARY!	E01-07	In the case of a redundant network, communication is occurring via the [SECONDARY] port.	Check the circuit that is connected to the [PRIMARY] port.
ERROR OCCURRED AT SECONDARY PORT!	E01-08	In the case of a redundant network, a problem has occurred in the circuit that is connected to the [SECONDARY] port.	Check the circuit that is connected to the [SECONDARY] port.
DANTE WORD CLOCK LEADER		Functioning correctly as the word clock leader.	This indicates that the device is the word clock leader.
DANTE IS NOT WORKING BY GIGA BIT!	E01-10	Functioning correctly as the word clock leader. A device that does not support gigabit Ethernet is connected.	This indicates that the device is the word clock leader. If you are conveying audio via Dante, use devices that support gigabit Ethernet.
DANTE IS WORKING AT SECONDARY!	E01-11	Functioning correctly as the word clock leader. In the case of a redundant network, communication is occurring via the [SECONDARY] port.	This indicates that the device is the word clock leader. Check the circuit that is connected to the [PRIMARY] port.
ERROR OCCURRED AT SECONDARY PORT!	E01-12	Functioning correctly as the word clock leader. In the case of a redundant network, a problem has occurred in the circuit that is connected to the [SECONDARY] port.	This indicates that the device is the word clock leader. Check the circuit that is connected to the [SECONDARY] port.

\* If the ID is blank, the message is shown. Otherwise, the ID is shown.

# Specifications

## General Specifications

Sampling Frequency	External	44.1 kHz +4.1667%, +0.1%, -0.1%, -4.0%	±200 ppm
		48 kHz +4.1667%, +0.1%, -0.1%, -4.0%	±200 ppm
		88.2 kHz +4.1667%, +0.1%, -0.1%, -4.0%	±200 ppm
		96 kHz +4.1667%, +0.1%, -0.1%, -4.0%	±200 ppm
Signal Delay	Less than 1.9 ms Rio-D2 INPUT to Rio-D2 OUTPUT connect with PM10 using Dante, Fs= 96 kHz. Dante Receive Latency set to 0.25 msec		
Frequency Response	+0.5, -1.5 dB 20 Hz-20 kHz, refer to +4 dBu output @1 kHz, INPUT to OUTPUT, Fs= 48 kHz +0.5, -1.5 dB 20 Hz-20 kHz, refer to +4 dBu output @1 kHz, INPUT to OUTPUT, Fs= 96 kHz		
Total Harmonic Distortion*1	Less than 0.05% 20 Hz-20 kHz@+4 dBu into 600Ω, Fs= 48 kHz Less than 0.05% 20 Hz-20 kHz@+4 dBu into 600Ω, Fs= 96 kHz INPUT to OUTPUT, Input Gain= Min.		
Hum&Noise*2	-128 dBu typ., Equivalent Input Noise, Input Gain= Max. -88 dBu Residual output noise, ST master off.		
Dynamic Range	112 dB typ., DA Converter, 108 dB typ., INPUT to OUTPUT, Input Gain= Min.		
Crosstalk@1 kHz	-100 dB*3, adjacent INPUT/OUTPUT channels, Input Gain= Min.		
Dimensions (WxHxD) and Net Weight	Rio3224-D2: 480 mm x 220 mm x 367.5 mm, 13.5 kg Rio1608-D2: 480 mm x 132 mm x 367.5 mm, 9.6 kg		
Power Requirements (wattage)	Rio3224-D2: 120 W Rio1608-D2: 72 W		
Power Requirements (voltage and hertz)	100-240V 50/60 Hz		
Temperature Range	Operating temperature range: 0 - 40°C Storage temperature range: -20 - 60°C		
NC value	Rio3224-D2 FAN MODE LOW: NC=20 / HIGH: NC=30 Rio1608-D2 FAN MODE LOW: NC=15 / HIGH: NC=25 Measurement position: 1 m from the front of the unit		
Included Accessories	Owner's Manual, AC power cord, Dante Virtual Soundcard Token leaflet		

\*1. Total Harmonic Distortion is measured with 18 dB/octave filter @80 kHz

\*2. Hum & Noise are measured with A-Weight filter.

\*3. Crosstalk is measured with a 30 dB/octave filter @22 kHz

## Analog Input Characteristics

Input Terminals	GAIN	Actual Load Impedance	For Use With Nominal	Input Level		Connector
				Nominal	Max. before clip	
INPUT 1-16	+66 dB	7.5 k $\Omega$	50-600 $\Omega$ Mics & 600 $\Omega$ Lines	-62 dBu (0.616 mV)	-42 dBu (6.16 mV)	XLR-3-31 type (Balanced) <sup>*1</sup>
	-6 dB			+10 dBu (2.45 V)	+30 dBu (24.5 V)	
INPUT 17-32 <sup>*2</sup>	+66 dB	7.5 k $\Omega$	50-600 $\Omega$ Mics & 600 $\Omega$ Lines	-62 dBu (0.616 mV)	-42 dBu (6.16 mV)	XLR-3-31 type (Balanced) <sup>*1</sup>
	-6 dB			+10 dBu (2.45 V)	+30 dBu (24.5 V)	

\*1. XLR-3-31 type connectors are balanced. (1= GND, 2= HOT, 3= COLD)

\*2. Rio3224-D2 only

\* In these specifications, 0 dBu= 0.775 Vrms.

\* +48V DC ( phantom power ) is supplied to INPUT XLR type connectors via each individual software controlled switch.

## Analog Output Characteristics

Output Terminals	Actual Source Impedance	For Use With Nominal	Max. Output Level Select SW <sup>*1</sup>	Output Level		Connector
				Nominal	Max. before clip	
OUTPUT 1-8	75 $\Omega$	600 $\Omega$ Lines	+24 dB (default)	+4 dBu (1.23 V)	+24 dBu (12.3 V)	XLR-3-32 type (Balanced) <sup>*2</sup>
			+18 dB	-2 dBu (616 mV)	+18 dBu (6.16 V)	
OUTPUT 9-16 <sup>*3</sup>	75 $\Omega$	600 $\Omega$ Lines	+24 dB (default)	+4 dBu (1.23 V)	+24 dBu (12.3 V)	XLR-3-32 type (Balanced) <sup>*2</sup>
			+18 dB	-2 dBu (616 mV)	+18 dBu (6.16 V)	

\*1. There are switches inside the body to preset the maximum output level.

\*2. XLR-3-32 type connectors are balanced. (1= GND, 2= HOT, 3= COLD )

\*3. Rio3224-D2 only

\* In these specifications, 0 dBu= 0.775 Vrms.

## Digital I/O Characteristics

Terminals	Format	Data length	Level	Audio	Connector
Primary/Secondary	Dante	24-bit or 32-bit	1000BASE-T	32ch (Rio3224-D2 to other devices) 24ch (Other devices to Rio3224-D2) 16ch (Rio1608-D2 to other devices) 8ch (Other devices to Rio1608-D2)	etherCON Cat5e

## Digital Output Characteristics

Terminal	Format	Data Length	Level	Connector
AES/EBU OUT 1-8 <sup>*1</sup>	AES/EBU	AES/EBU Professional use <sup>*1</sup>	24-bit	RS422 XLR-3-32 type (Balanced) <sup>*2</sup>

\*1. Rio3224-D2 only

\*2. XLR-3-32 type connectors are balanced. (1= GND, 2= HOT, 3= COLD)



# Dimensions

## Rio3224-D2

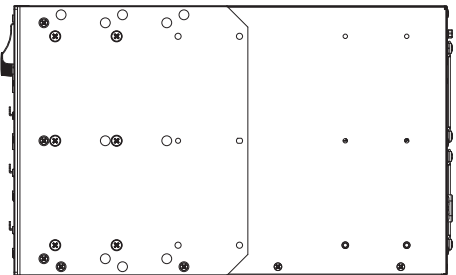
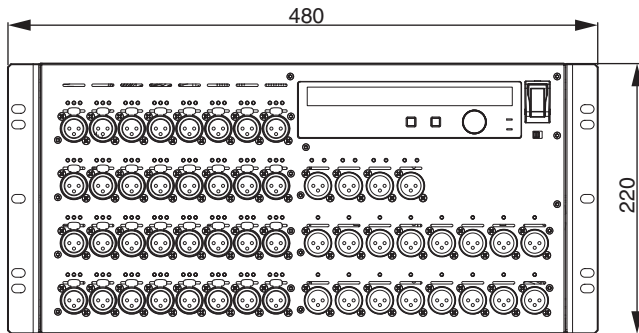
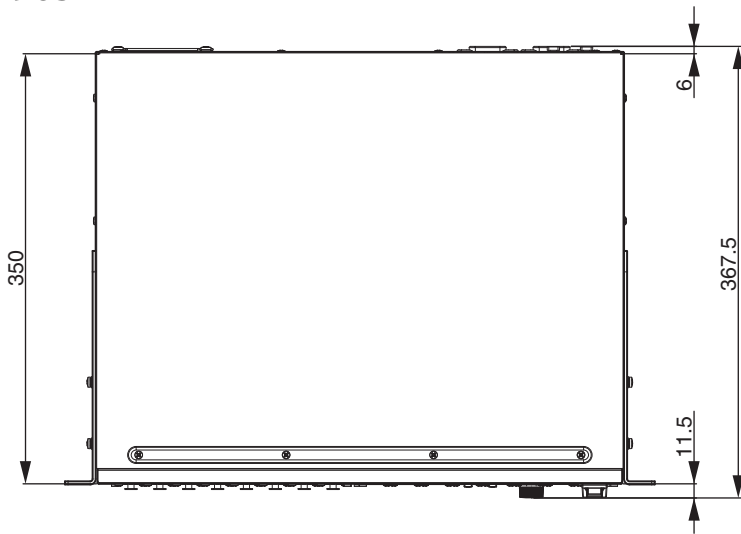

## Rio1608-D2

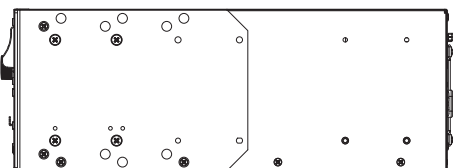
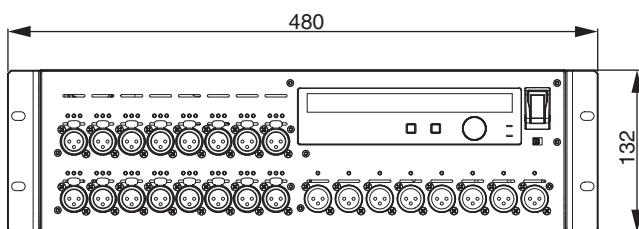
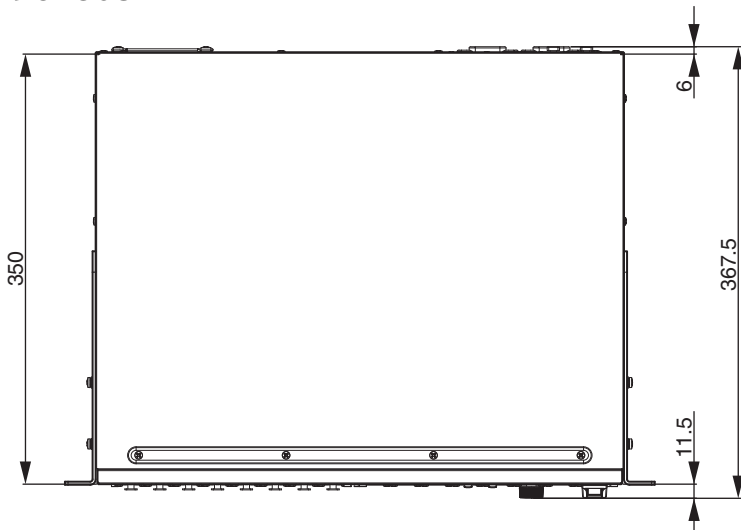

Unit: mm

\* The contents of this manual apply to the latest specifications as of the publishing date. To obtain the latest manual, access the Yamaha website then download the manual file.

# Important Notice: Guarantee Information for customers in European Economic Area (EEA) and Switzerland

<b>Important Notice: Guarantee Information for customers in EEA* and Switzerland</b> For detailed guarantee information about this Yamaha product, and Pan-EEA* and Switzerland warranty service, please either visit the website address below (Printable file is available at our website) or contact the Yamaha representative office for your country. * EEA: European Economic Area	<b>English</b>
<b>Wichtiger Hinweis: Garantie-Information für Kunden in der EWR* und der Schweiz</b> Für nähere Garantie-Information über dieses Produkt von Yamaha, sowie über den Pan-EWR*- und Schweizer Garantieservice, besuchen Sie bitte entweder die folgend angegebene Internetadresse (eine druckfähige Version befindet sich auch auf unserer Webseite), oder wenden Sie sich an den für Ihr Land zuständigen Yamaha-Vertrieb. *EWR: Europäischer Wirtschaftsraum	<b>Deutsch</b>
<b>Remarque importante: informations de garantie pour les clients de l'EEE et la Suisse</b> Pour des informations plus détaillées sur la garantie de ce produit Yamaha et sur le service de garantie applicable dans l'ensemble de l'EEE ainsi qu'en Suisse, consultez notre site Web à l'adresse ci-dessous (le fichier imprimable est disponible sur notre site Web) ou contactez directement Yamaha dans votre pays de résidence. * EEE : Espace Economique Européen	<b>Français</b>
<b>Belangrijke mededeling: Garantie-informatie voor klanten in de EER* en Zwitserland</b> Voor gedetailleerde garantie-informatie over dit Yamaha-product en de garantieservice in heel de EER* en Zwitserland, gaat u naar de onderstaande website (u vindt een afdrukbaar bestand op onze website) of neemt u contact op met de vertegenwoordiging van Yamaha in uw land. * EER: Europese Economische Ruimte	<b>Nederlands</b>
<b>Aviso importante: información sobre la garantía para los clientes del EEE* y Suiza</b> Para una información detallada sobre este producto Yamaha y sobre el soporte de garantía en la zona EEE* y Suiza, visite la dirección web que se incluye más abajo (la versión del archivo para imprimir esta disponible en nuestro sitio web) o póngase en contacto con el representante de Yamaha en su país. * EEE: Espacio Económico Europeo	<b>Español</b>
<b>Avviso importante: informazioni sulla garanzia per i clienti residenti nell'EEA* e in Svizzera</b> Per informazioni dettagliate sulla garanzia relativa a questo prodotto Yamaha e l'assistenza in garanzia nei paesi EEA* e in Svizzera, potete consultare il sito Web all'indirizzo riportato di seguito (è disponibile il file in formato stampabile) oppure contattare l'ufficio di rappresentanza locale della Yamaha. * EEA: Area Economica Europea	<b>Italiano</b>
<b>Aviso importante: informações sobre as garantias para clientes da AEE* e da Suíça</b> Para obter uma informação pormenorizada sobre este produto da Yamaha e sobre o serviço de garantia na AEE* e na Suíça, visite o site a seguir (o arquivo para impressão está disponível no nosso site) ou entre em contato com o escritório de representação da Yamaha no seu país. * AEE: Área Económica Européia	<b>Português</b>
<b>Σημαντική σημείωση: Πληροφορίες εγγύησης για τους πελάτες στον ΕΟΧ* και Ελλάδα</b> Για λεπτομερείς πληροφορίες εγγύησης σχετικά με το παρόν προϊόν της Yamaha και την κάλυψη εγγύησης σε όλες τις χώρες του ΕΟΧ και την Ελλάδα, επισκεφτείτε την παρακάτω ιστοσελίδα (Εκτυπώσιμη μορφή είναι διαθέσιμη στην ιστοσελίδα μας) ή απευθυνθείτε στην αντιπροσωπεία της Yamaha στη χώρα σας. * ΕΟΧ: Ευρωπαϊκός Οικονομικός Χώρος	<b>Ελληνικά</b>
<b>Viktigt: Garantiinformation för kunder i EES-området* och Schweiz</b> För detaljerad information om denna Yamahaprodukt samt garantiservice i hela EES-området* och Schweiz kan du antingen besöka nedanstående webbadress (en utskriftsvänlig fil finns på webbplatsen) eller kontakta Yamahas officiella representant i ditt land. * EES: Europeiska Ekonomiska Samarbetsområdet	<b>Svenska</b>
<b>Viktig merknad: Garantiinformasjon for kunder i EØS* og Sveits</b> Detaljert garantiinformasjon om dette Yamaha-produktet og garantiservice for hele EØS-området* og Sveits kan fås enten ved å besøke nettadressen nedenfor (utskriftsversjon finnes på våre nettsider) eller kontakte Yamahas kontoret i landet der du bor. *EØS: Det europeiske økonomiske samarbeidsområdet	<b>Norsk</b>
<b>Vigtig oplysning: Garantioplysninger til kunder i EØO* og Schweiz</b> De kan finde detaljerede garantioplysninger om dette Yamaha-produkt og den fælles garantiserviceordning for EØO* (og Schweiz) ved at besøge det websted, der er angivet nedenfor (der findes en fil, som kan udskrives, på vores websted), eller ved at kontakte Yamahas nationale repræsentationskontor i det land, hvor De bor. * EØO: Det Europæiske Økonomiske Område	<b>Dansk</b>
<b>Tärkeä ilmoitus: Takuutiedot Euroopan talousalueen (ETA)* ja Sveitsin asiakkaille</b> Tämän Yamaha-tuotteen sekä ETA-alueen ja Sveitsin takuuta koskevat yksityiskohtaiset tiedot saatte alla olevasta nettiosoitteesta. (Tulostettava tiedosto saatavissa sivustollamme.) Voitte myös ottaa yhteyttä paikalliseen Yamaha-edustajaan. *ETA: Euroopan talousalue	<b>Suomi</b>
<b>Ważne: Warunki gwarancyjne obowiązujące w EOG* i Szwajcarii</b> Aby dowiedzieć się więcej na temat warunków gwarancyjnych tego produktu firmy Yamaha i serwisu gwarancyjnego w całym EOG* i Szwajcarii, należy odwiedzić wskazaną poniżej stronę internetową (Plik gotowy do wydruku znajduje się na naszej stronie internetowej) lub skontaktować się z przedstawicielstwem firmy Yamaha w swoim kraju. * EOG — Europejski Obszar Gospodarczy	<b>Polski</b>
<b>Důležité oznámení: Záruční informace pro zákazníky v EHS* a ve Švýcarsku</b> Podrobné záruční informace o tomto produktu Yamaha a záručním servisu v celém EHS* a ve Švýcarsku naleznete na níže uvedené webové adrese (soubor k tisku je dostupný na našich webových stránkách) nebo se můžete obrátit na zastoupení firmy Yamaha ve své zemi. * EHS: Evropský hospodářský prostor	<b>Česky</b>
<b>Fontos figyelmeztetés: Garancia-információk az EGT* területén és Svájcban élő vásárlók számára</b> A jelen Yamaha termékre vonatkozó részletes garancia-információk, valamint az EGT*-re és Svájcra kiterjedő garanciális szolgáltatás tekintetében keresse fel webhelyünket az alábbi címen (a webhelyen nyomtatható fájl is talál), vagy pedig lépjen kapcsolatba az országában működő Yamaha képviselői irodával. * EGT: Európai Gazdasági Térség	<b>Magyar</b>
<b>Oluline märkus: Garantiiteave Euroopa Majanduspiirkonna (EMP)* ja Šveitsi klientidele</b> Täpsema teabe saamiseks selle Yamaha toote garantii ning kogu Euroopa Majanduspiirkonna ja Šveitsi garantiiteeninduse kohta, külastage palun veebisaiti alljärgneval aadressil (meie saidil on saadaval prinditav fail) või pöörduge Teie regiooni Yamaha esinduse poole. * EMP: Euroopa Majanduspiirkond	<b>Eesti keel</b>
<b>Svarīgs paziņojums: garantijas informācija klientiem EEZ* un Šveicē</b> Lai saņemtu detalizētu garantijas informāciju par šo Yamaha produktu, kā arī garantijas apkalpošanu EEZ* un Šveicē, lūdzu, apmeklējiet zemāk norādīto tīmekļa vietnes adresi (tīmekļa vietnē ir pieejams drukājams fails) vai sazinieties ar jūsu valsti apkalpojošo Yamaha pārstāvniecību. * EEZ: Eiropas Ekonomikas zona	<b>Latviešu</b>
<b>Dėmesio: informacija dėl garantijos pirkėjams EEE* ir Šveicarijoje</b> Jei reikia išsamios informacijos apie šį „Yamaha“ produktą ir jo techninę priežiūrą visoje EEE* ir Šveicarijoje, apsilankykite mūsų svetainėje toliau nurodytu adresu (svetainėje yra spausdinamas failas) arba kreipkitės į „Yamaha“ atstovybę savo šaliai. *EEE – Europos ekonominė erdvė	<b>Lietuvių kalba</b>
<b>Dôležité upozornenie: Informácie o záruke pre zákazníkov v EHP* a Švajčiarsku</b> Podrobné informácie o záruke týkajúce sa tohto produktu od spoločnosti Yamaha a garančnom servise v EHP* a Švajčiarsku nájdete na webovej stránke uvedenej nižšie (na našej webovej stránke je k dispozícii súbor na tlač) alebo sa obráťte na zástupcu spoločnosti Yamaha vo svojej krajine. * EHP: Európsky hospodársky priestor	<b>Slovenčina</b>
<b>Pomembno obvestilo: Informacije o garanciji za kupce v EGP* in Švici</b> Za podrobnejše informacije o tem Yamahinem izdelku ter garancijskem servisu v celotnem EGP in Švici, obiščite spletno mesto, ki je navedeno spodaj (natisljiva datoteka je na voljo na našem spletnem mestu), ali se obrnite na Yamahinega predstavnika v svoji državi. * EGP: Evropski gospodarski prostor	<b>Slovenščina</b>
<b>Важно съобщение: Информация за гаранцията за клиенти в ЕИП* и Швейцария</b> За подробна информация за гаранцията за този продукт на Yamaha и гаранционното обслужване в паневропейската зона на ЕИП* и Швейцария или посетете посочения по-долу уеб сайт (на нашия уеб сайт има файл за печат), или се свържете с представителния офис на Yamaha във вашата страна. * ЕИП: Европейско икономическо пространство	<b>Български език</b>
<b>Notificare importantă: Informații despre garanție pentru clienții din SEE* și Elveția</b> Pentru informații detaliate privind acest produs Yamaha și serviciul de garanție Pan-SEE* și Elveția, vizitați site-ul la adresa de mai jos (fișierul imprimabil este disponibil pe site-ul nostru) sau contactați biroul reprezentanței Yamaha din țara dumneavoastră. * SEE: Spațiul Economic European	<b>Limba română</b>
<b>Važna obavijest: Informacije o jamstvu za države EGP-a i Švicarske</b> Za detaljne informacije o jamstvu za ovaj Yamahin proizvod te jamstvenom servisu za cijeli EGP i Švicarsku, molimo Vas da posjetite web-stranicu navedenu u nastavku ili kontaktirate ovlaštenog Yamahinog dobavljača u svojoj zemlji. * EGP: Evropski gospodarski prostor	<b>Hrvatski</b>

<https://europe.yamaha.com/warranty/>

## ADDRESS LIST

### NORTH AMERICA

#### CANADA

**Yamaha Canada Music Ltd.**  
135 Milner Avenue, Toronto, Ontario,  
M1S 3R1, Canada  
Tel: +1-416-298-1311

#### U.S.A.

**Yamaha Corporation of America**  
6600 Orangethorpe Avenue, Buena Park, CA 90620,  
U.S.A.  
Tel: +1-714-522-9011

### CENTRAL & SOUTH AMERICA

#### MEXICO

**Yamaha de México, S.A. de C.V.**  
Av. Insurgentes Sur 1647 Piso 9, Col. San José  
Insurgentes, Delegación Benito Juárez, CDMX,  
C.P. 03900, México  
Tel: +52-55-5804-0600

#### BRAZIL

**Yamaha Musical do Brasil Ltda.**  
Praça Professor José Lannes, 40, Cjs 21 e 22, Brooklin  
Paulista Novo CEP 04571-100 – São Paulo – SP,  
Brazil  
Tel: +55-11-3704-1377

#### ARGENTINA

**Yamaha Music Latin America, S.A.,  
Sucursal Argentina**  
Olga Cossettini 1553, Piso 4 Norte,  
Madero Este-C1107CEK,  
Buenos Aires, Argentina  
Tel: +54-11-4119-7000

#### PANAMA AND OTHER LATIN

#### AMERICAN/CARIBBEAN REGIONS

**Yamaha Music Latin America, S.A.**  
Edif. Torre Banco General, Piso 7, Urbanización  
Marbella, Calle 47 y Aquilino de la Guardia,  
Ciudad de Panamá, República de Panamá  
Tel: +507-269-5311

### EUROPE

#### THE UNITED KINGDOM/IRELAND

**Yamaha Music Europe GmbH (UK)**  
Sherbourne Drive, Tilbrook, Milton Keynes,  
MK7 8BL, U.K.  
Tel: +44-1908-366700

#### GERMANY

**Yamaha Music Europe GmbH**  
Siemensstrasse 22-34, 25462 Rellingen, Germany  
Tel: +49-4101-303-0

#### SWITZERLAND/LIECHTENSTEIN

**Yamaha Music Europe GmbH, Branch  
Switzerland in Thalwil**  
Seestrasse 18a, 8800 Thalwil, Switzerland  
Tel: +41-44-3878080

#### AUSTRIA/BULGARIA/ CZECH REPUBLIC/HUNGARY/ ROMANIA/SLOVAKIA/SLOVENIA

**Yamaha Music Europe GmbH  
Branch Austria**  
Schleiergasse 20, 1100 Wien, Austria  
Tel: +43-1-60203900

#### POLAND

**Yamaha Music Europe GmbH  
Sp.z o.o. Oddział w Polsce**  
ul. Wielicka 52, 02-657 Warszawa, Poland  
Tel: +48-22-880-08-88

#### MALTA

**Olimpus Music Ltd.**  
Valletta Road, Mosta MST9010, Malta  
Tel: +356-2133-2093

#### NETHERLANDS/BELGIUM/ LUXEMBOURG

**Yamaha Music Europe Branch Benelux**  
Clarissenhof 5b, 4133 AB Vianen, The Netherlands  
Tel: +31-347-358040

#### FRANCE

**Yamaha Music Europe**  
7 rue Ambroise Croizat, Zone d'activités de Pariest,  
77183 Croissy-Beaubourg, France  
Tel: +33-1-6461-4000

#### ITALY

**Yamaha Music Europe GmbH, Branch Italy**  
Via Tinelli N.67/69 20855 Gerno di Lesmo (MB),  
Italy  
Tel: +39-039-9065-1

#### SPAIN/PORTUGAL

**Yamaha Music Europe GmbH Ibérica, Sucursal  
en España**  
Ctra. de la Coruña km. 17,200, 28231  
Las Rozas de Madrid, Spain  
Tel: +34-91-639-88-88

#### GREECE

**Philippos Nakas S.A. The Music House**  
19th klm. Leof. Lavriou 190 02 Peania – Attiki,  
Greece  
Tel: +30-210-6686168

#### SWEDEN/FINLAND/ICELAND

**Yamaha Music Europe GmbH Germany filial  
Scandinavia**  
JA Wettergrensgata 1, 400 43 Göteborg, Sweden  
Tel: +46-31-89-34-00

#### DENMARK

**Yamaha Music Denmark,  
Fillial of Yamaha Music Europe GmbH, Tyskland**  
Generatorvej 8C, ST. TH. , 2860 Søborg, Denmark  
Tel: +45-44-92-49-00

#### NORWAY

**Yamaha Music Europe GmbH Germany -  
Norwegian Branch**  
Grini Næringspark 1, 1332 Østerås, Norway  
Tel: +47-6716-7800

#### CYPRUS

**Yamaha Music Europe GmbH**  
Siemensstrasse 22-34, 25462 Rellingen, Germany  
Tel: +49-4101-303-0

#### RUSSIA

**Yamaha Music (Russia) LLC.**  
Room 37, entrance 7, bld. 7, Kievskaya street,  
Moscow, 121059, Russia  
Tel: +7-495-626-5005

#### OTHER EUROPEAN REGIONS

**Yamaha Music Europe GmbH**  
Siemensstrasse 22-34, 25462 Rellingen, Germany  
Tel: +49-4101-3030

### AFRICA

**Yamaha Music Gulf FZE**  
JAFZA-16, Office 512, P.O.Box 17328,  
Jebel Ali FZE, Dubai, UAE  
Tel: +971-4-801-1500

### MIDDLE EAST

#### TURKEY

**Yamaha Music Europe GmbH  
Merkezi Almanya Türkiye İstanbul Şubesi**  
Mor Sumbul Sokak Varyap Meridian Business  
1.Blok No:1 113-114-115  
Bati Atasehir İstanbul, Turkey  
Tel: +90-216-275-7960

#### OTHER REGIONS

**Yamaha Music Gulf FZE**  
JAFZA-16, Office 512, P.O.Box 17328,  
Jebel Ali FZE, Dubai, UAE  
Tel: +971-4-801-1500

### ASIA

#### THE PEOPLE'S REPUBLIC OF CHINA

**Yamaha Music & Electronics (China) Co.,Ltd.**  
2F, Yunhedasha, 1818 Xinzha-lu, Jingan-qu,  
Shanghai, China  
Tel: +86-400-051-7700

#### INDIA

**Yamaha Music India Private Limited**  
P-401, JMD Megapolis, Sector-48, Sohna Road,  
Gurugram-122018, Haryana, India  
Tel: +91-124-485-3300

#### INDONESIA

**PT Yamaha Musik Indonesia Distributor**  
Yamaha Music Center Bldg. Jalan Jend. Gatot  
Subroto Kav. 4, Jakarta 12930, Indonesia  
Tel: +62-21-520-2577

#### KOREA

**Yamaha Music Korea Ltd.**  
11F, Prudential Tower, 298, Gangnam-daero,  
Gangnam-gu, Seoul, 06253, Korea  
Tel: +82-2-3467-3300

#### MALAYSIA

**Yamaha Music (Malaysia) Sdn. Bhd.**  
No.8, Jalan Perbandaran, Kelana Jaya, 47301  
Petaling Jaya, Selangor, Malaysia  
Tel: +60-3-78030900

#### SINGAPORE

**Yamaha Music (Asia) Private Limited**  
Block 202 Hougang Street 21, #02-00,  
Singapore 530202, Singapore  
Tel: +65-6740-9200

#### TAIWAN

**Yamaha Music & Electronics Taiwan Co.,Ltd.**  
2F., No.1, Yuandong Rd., Banqiao Dist.,  
New Taipei City 22063, Taiwan (R.O.C.)  
Tel: +886-2-7741-8888

#### THAILAND

**Siam Music Yamaha Co., Ltd.**  
3, 4, 15, 16th Fl., Siam Motors Building,  
891/1 Rama 1 Road, Wangmai,  
Pathumwan, Bangkok 10330, Thailand  
Tel: +66-2215-2622

#### VIETNAM

**Yamaha Music Vietnam Company Limited**  
15th Floor, Nam A Bank Tower, 201-203 Cach  
Mang Thang Tam St., Ward 4, Dist.3,  
Ho Chi Minh City, Vietnam  
Tel: +84-8-3818-1122

#### OTHER ASIAN REGIONS

<http://asia.yamaha.com/>

### OCEANIA

#### AUSTRALIA

**Yamaha Music Australia Pty. Ltd.**  
Level 1, 80 Market Street, South Melbourne,  
VIC 3205, Australia  
Tel: +61-3-9693-5111

#### REGIONS AND TRUST TERRITORIES IN PACIFIC OCEAN

<http://asia.yamaha.com/>

Head Office/Manufacturer: Yamaha Corporation 10-1, Nakazawa-cho, Naka-ku, Hamamatsu, 430-8650, Japan

Importer (European Union): Yamaha Music Europe GmbH Siemensstrasse 22-34, 25462 Rellingen, Germany

Importer (United Kingdom): Yamaha Music Europe GmbH (UK) Sherbourne Drive, Tilbrook, Milton Keynes, MK7 8BL, United Kingdom

Yamaha Pro Audio global website  
<http://www.yamahaproaudio.com/>  
Yamaha Downloads  
<https://download.yamaha.com/>

Manual Development Group  
© 2017 Yamaha Corporation  
Published 08/2021  
IPES-D0

VFH2270