



SRv6

Technology and Deployment Use-Cases

Clarence Filsfils

Cisco Fellow – cf@cisco.com

An extended recording
of this presentation is
available at

segment-routing.net/srv6-status/

SR-MPLS: de-facto IPv4 solution

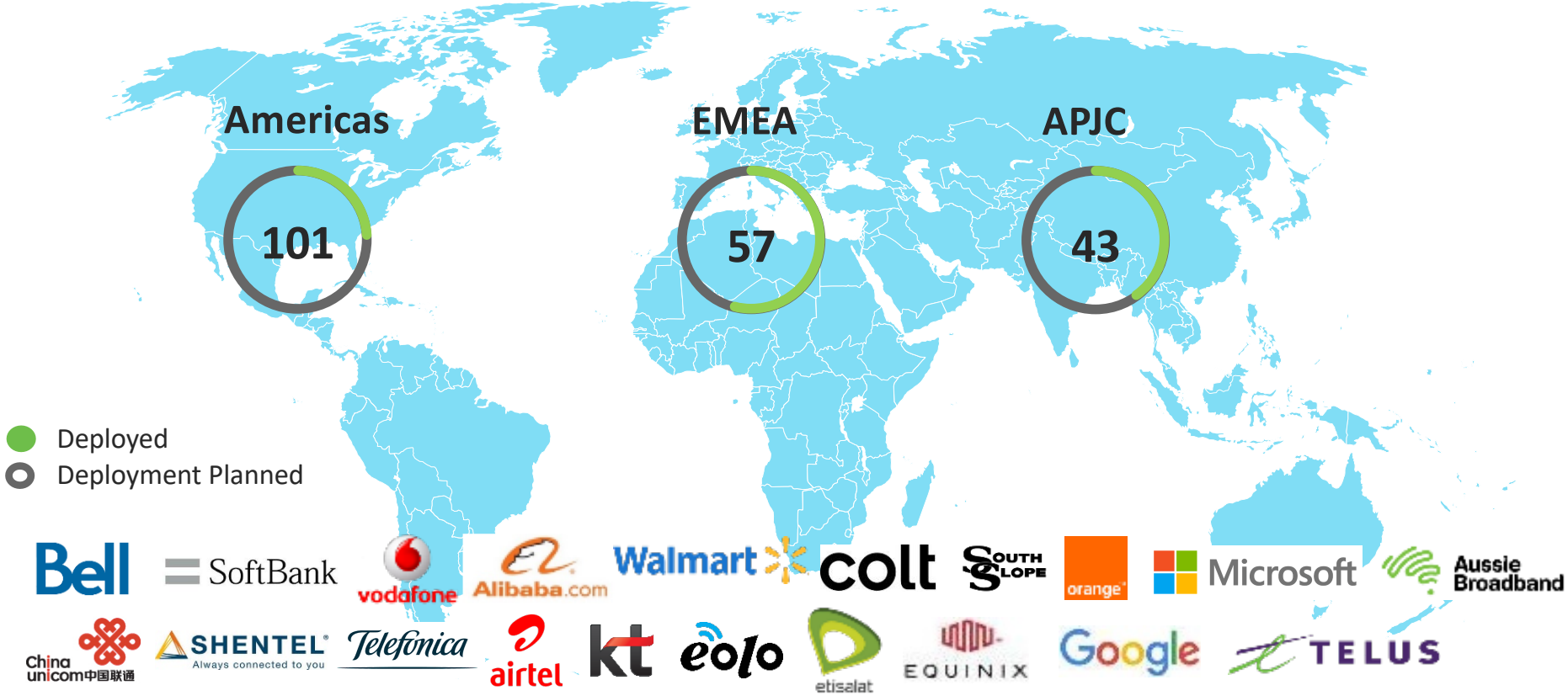

Let's focus on SRv6: SR for IPv6

Simplicity Always Prevails



- ~~LDP~~
- ~~RSVP-TE~~
- ~~Inter-AS Option A/B/C~~
- ~~MPLS~~
- ~~UDP/VxLAN~~
- ~~NSH~~

Furthermore with more scale and functionality

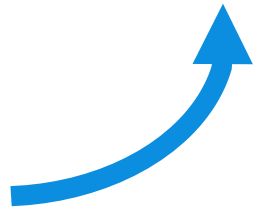

SRv6 Eco-System



At record speed

- In 2019: 8 large-scale commercial deployments
 - Softbank, Iliad, China Telecom, LINE corporation, China Unicom, CERNET2, China Bank and Uganda MTN.
- 18 HW linerate implementations
 - Cisco Systems, Huawei
 - Broadcom, Barefoot, Intel, Marvell, Mellanox
 - Multiple Interop Reports
- 11 open-source platforms/ Applications
 - Linux, FD.io VPP, P4, Wireshark, tcpdump, iptables, nftables, snort, ExaBGP, Contiv-VPP



- Nationwide deployment in Italy
- 1000 Cisco NCS 5500
- 1800 Iliad Nodeboxes

Re: [spring] SPRING SRv6 Deployment Status draft

Sébastien Parisot <sparisot@free-mobile.fr> | Tue, 10 December 2019 09:34 UTC | [Show header](#)

Hi Satoru, Zafar,

I would like to provide an update to SRv6 deployment in Iliad's nationwide network in Italy.

As of the end of 2019, the SRv6 network consists of:

- 1000 Cisco NCS 5500 routers
- 1800 Iliad's Nodeboxes
- The network services 4.5 million mobile subscribers (as of Q3 2019)
- The network is carrying 300 Gbps of commercial traffic at peak hours
- It is expected to grow to more than 4000 Nodeboxes in 2020.

The following SRv6 features have been deployed:

- A Segment Routing Header based data plane
- End (PSP), End.X (PSP), End.DT4, T.Encaps.Red, T.Insert.Red functions
- BGP VPN SRv6 extensions
- ISIS SRv6 extensions
- SRH-based Topology Independent (TI-LFA) Fast Reroute mechanisms
- Support for ping and traceroute

Can you please update the SRv6 deployment draft accordingly?

Thanks,
Sébastien



SRv6 Ecosystem

Network Equipment Manufacturers



Merchant Silicon



Open-Source Applications



Open-Source Networking Stacks



Smart NIC



NFV Partners

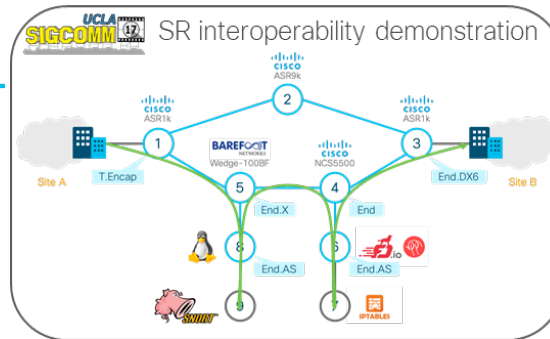

SRv6 is a Proposed Standard

- RFC 8402 - Architecture
 - Defines SRv6 with SRH and SRv6 SID's
- RFC xxxx – SR Extension Header (SRH)
 - Defines the SRv6 dataplane encapsulation
- Last-Call status
 - Net Pgm
 - ISIS
 - OAM

Shipping: Cisco NCS5500, NCS560, NCS540, ASR9k

- **ISIS**
 - TILFA and uLoop
 - Flex-Algo (Low-Delay Slice) with TILFA
- **BGP**
 - PIC Core/Edge
 - L3VPN (IPv4)
 - Internet (IPv4)
 - eVPN VPWS
- **SRv6-SR-MPLS Gateway**
- **OAM**
 - Ping
 - Trace
 - SID Verification

Shipping: DC – Cisco Nexus 9K GX series

Nexus 9K Platforms

- 16 X 400G
- 28x100G+8x400G
- 64x100G

N9K-C9316D-GX



N9K-C93600CD-GX



N9K-C9364C-GX



SRv6 forwarding performance

- 400G Line-rate Performance for SRv6
- 6.4 TBPS Packet Processing
- Insert up to 9 SIDs @ line-rate

- IS-IS, OSPFv3
- BGP
 - L3VPN (IPv4, IPv6)
 - Internet (IPv4, IPv6)
- VxLAN – SRv6 gateway
- OAM
 - Ping
 - Trace
 - SID verification

SRv6 - Reminder



Network Programming

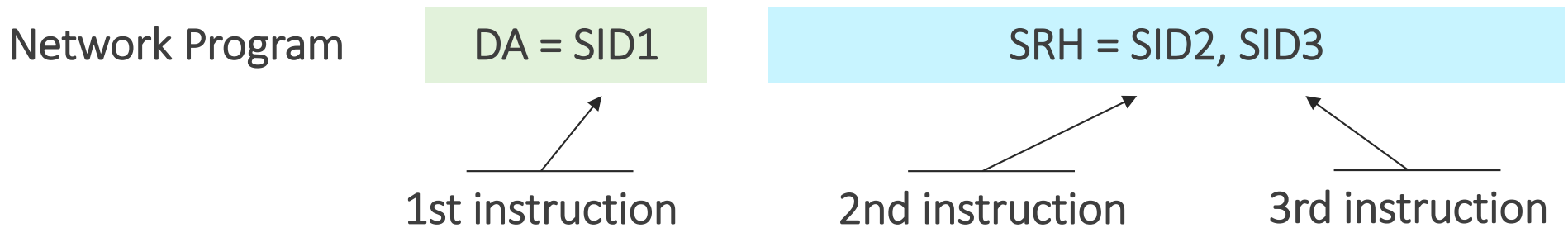

- A network program is a list of instructions (128-bit SRv6 SID)
- An instruction can be bound to any behavior
 - TE/FRR: END, END.X
 - VPN: END.DX, END.DT

SRv6 Header

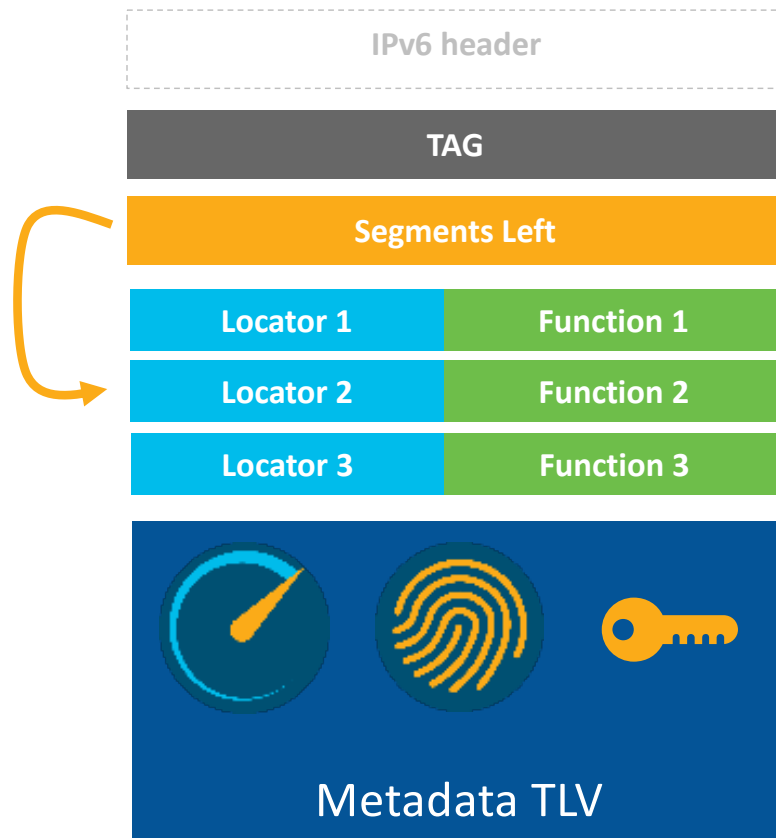

RFC – Proposed Standard
18 HW linerate implementations
8 deployments

Optimized for HW processing
e.g. FRR, TE & VPN use-cases

Optimized for SW processing
e.g. NFV, Container, Micro-Service

SRv6 Domain

IPv6 enabled provider infrastructure
SR Domain

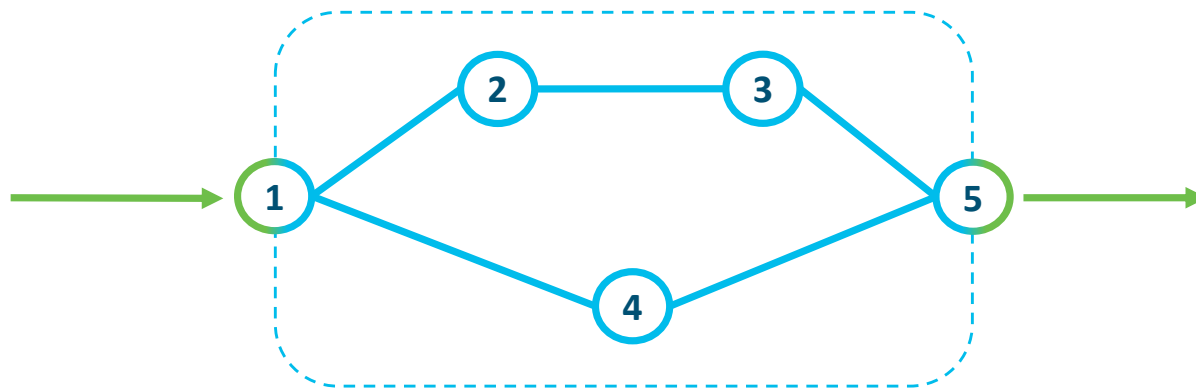

Encapsulation at the Domain ingress

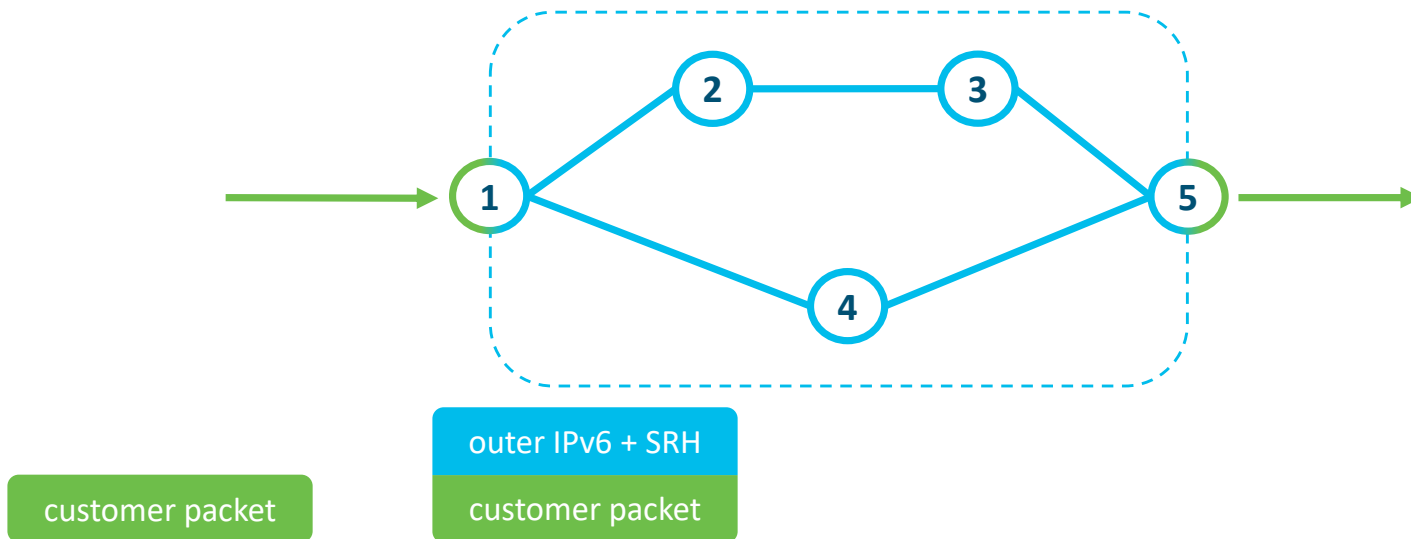

- IPv4, IPv6 or L2 frame is encapsulated within the SR Domain
- Outer IPv6 header includes an SRH with the list of segments

SRH of the outer IPv6 encapsulation

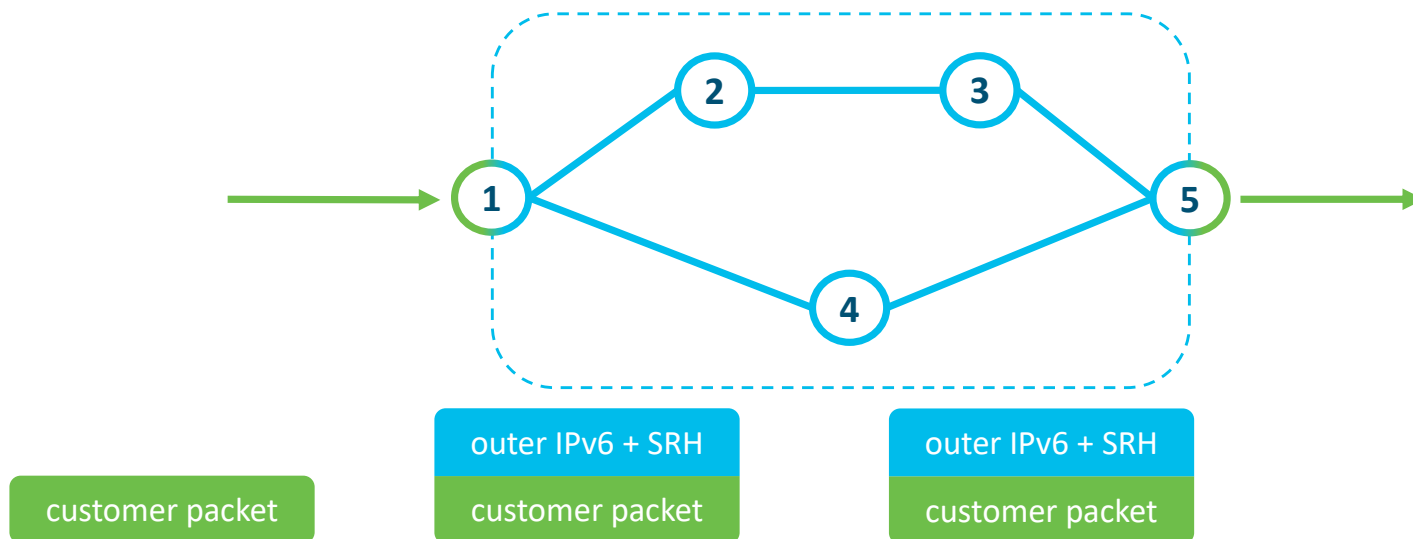

- Domain acts as a giant computer
- The network program in the outer SRH is executed

Decapsulation at Domain Egress

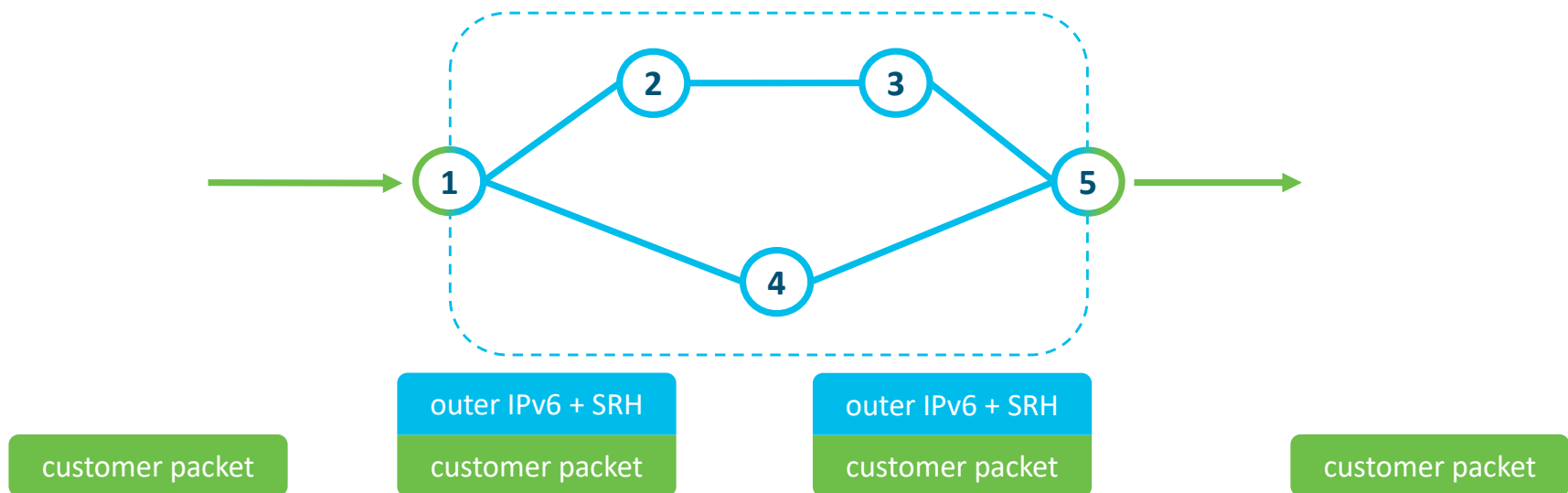

- Egress PE removes the outer IPv6 header as the packet leaves the SR domain

End-to-End Integrity

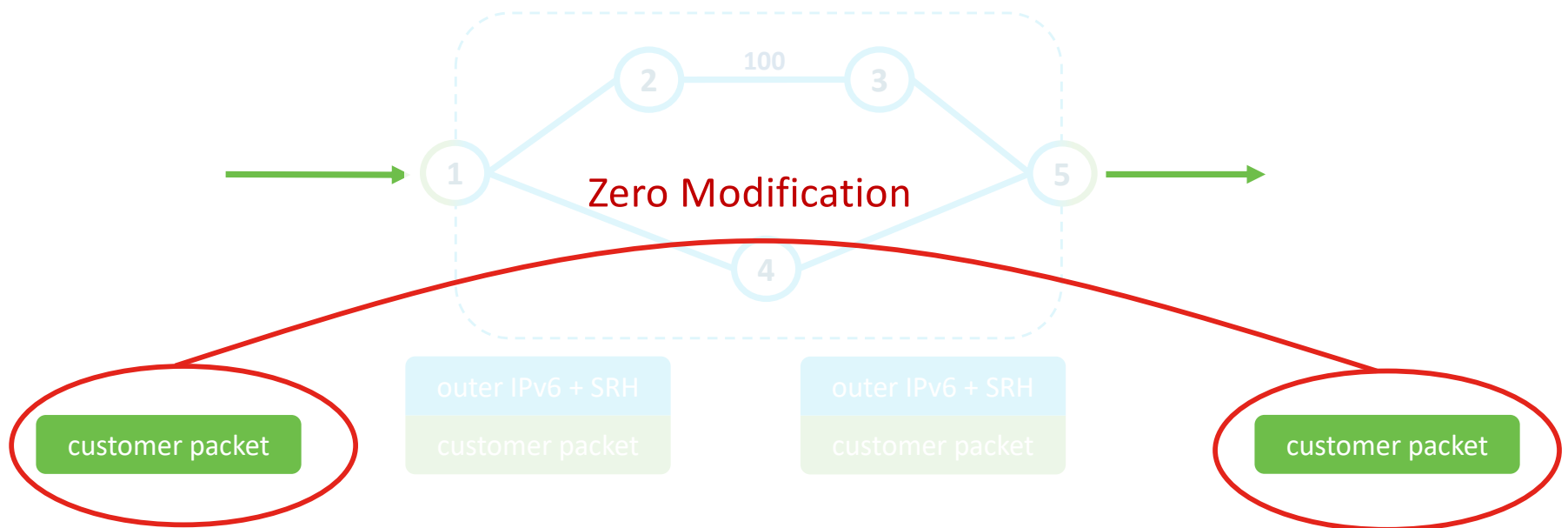

- End-to-end integrity principle is strictly guaranteed
 - Inner packet is unmodified
 - Same as SR-MPLS (MPLS stack is replaced by IPv6 outer header and SRH)

SRv6 Deployed Use-Cases



VPN over Best-Effort 5G Slice

Network Program: B:3:V(9)

B: locator block is associated with ISIS base algo (Low Cost, Best Effort)

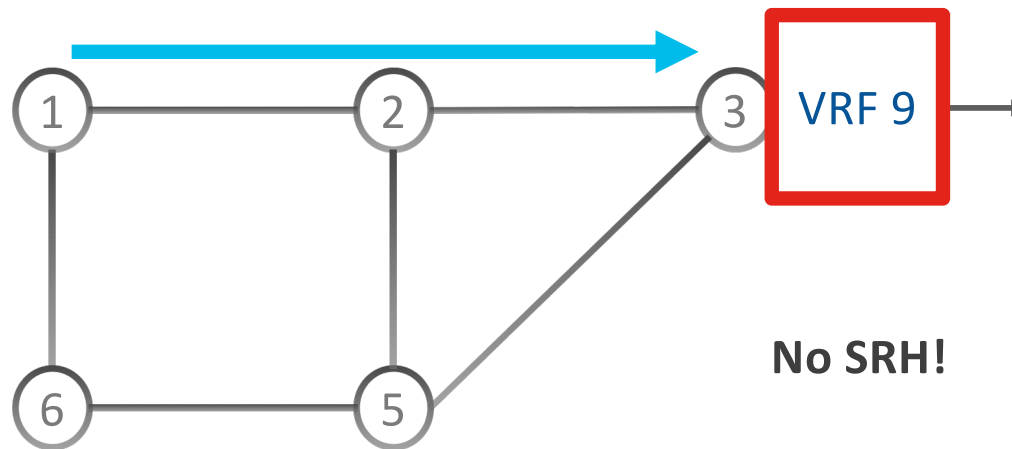

VPN with Low-Delay 5G Slice – SR-TE option

Network Program: B:2:C5 then B:3:V(9)

B: locator block is associated with ISIS base algo (Low Cost)

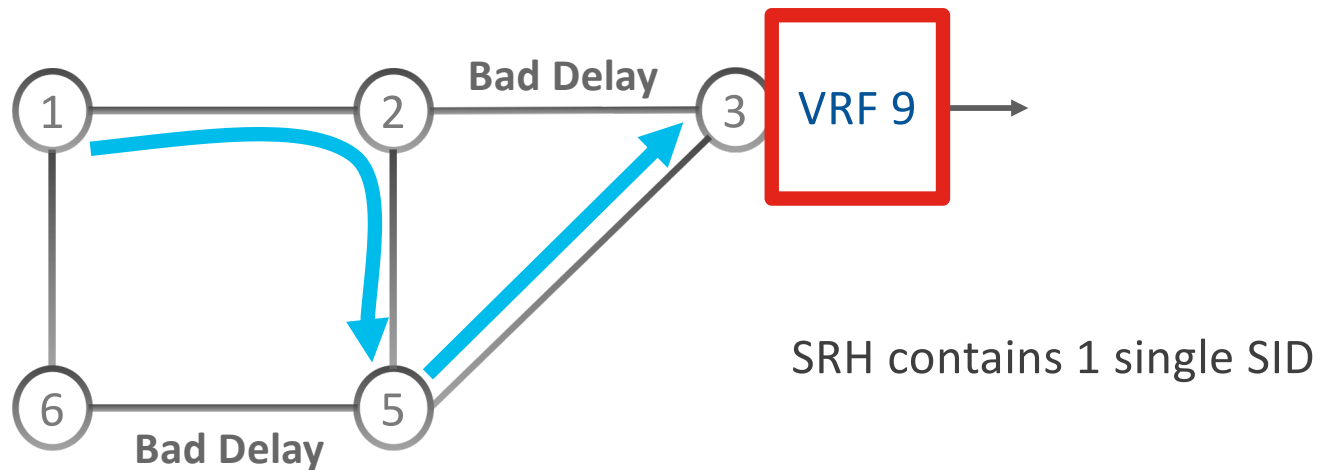

VPN with Low-Delay 5G Slice – Flex-algo option

Network Program: D:3:V(9)

D: locator block is associated with Low Delay Flex-Algo

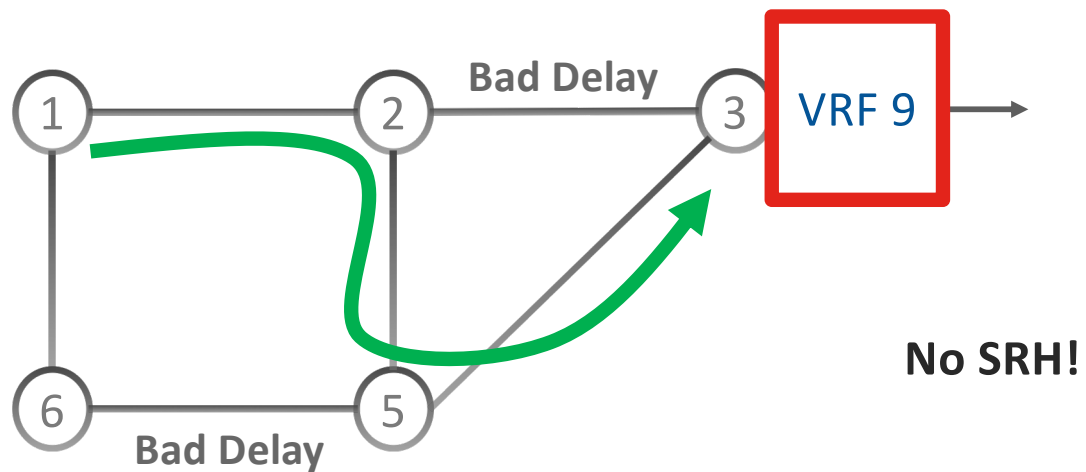

Snort firewall, VPN & Low-Delay Slice

Network Program: D:2:SNORT then D:3:V(9)

D: locator block is associated with Low Delay Flex-Algo

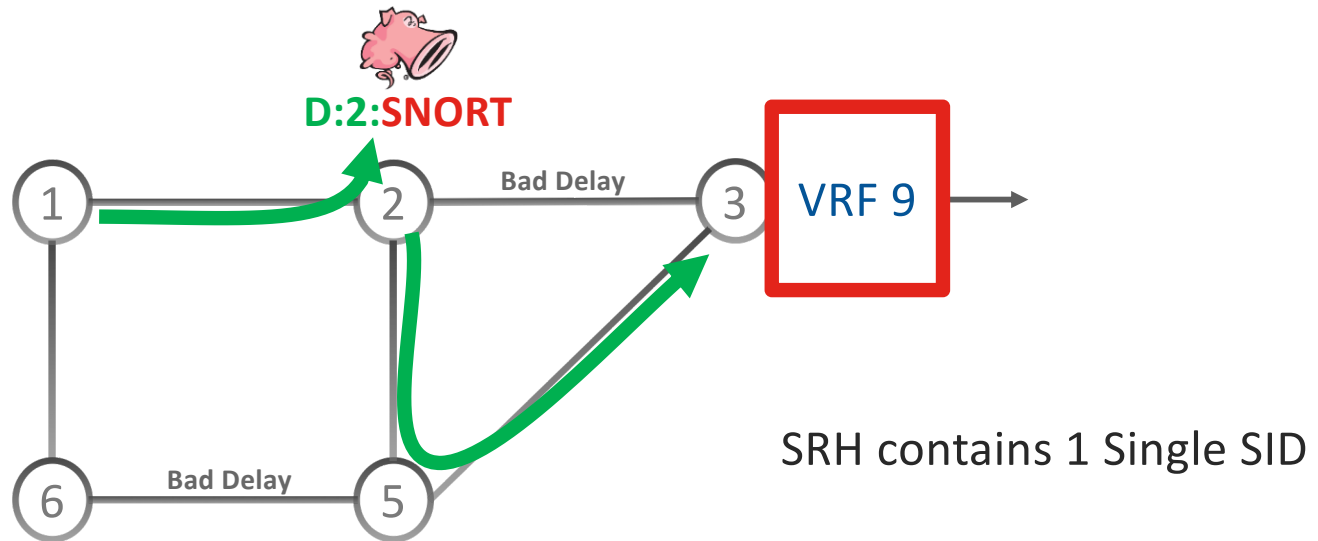

Load-balancing

- 20-bit entropy
- No additional protocol
 - infamous mpls entropy label

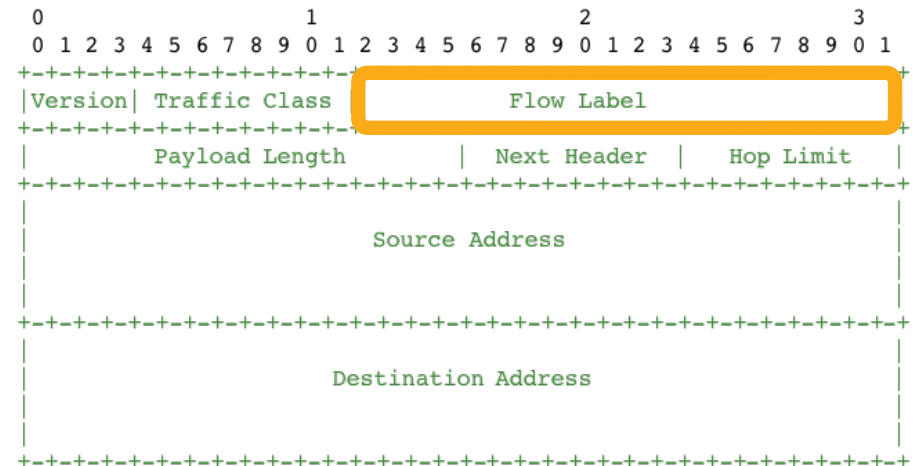

Seamless Incremental Deployment

- As soon as the network supports plain IPv6 forwarding
 - A new SRv6-VPN service only requires PE upgrade
 - TE objective can be achieved with a few well selected TE waypoints
 - FRR is deployed incrementally

Prefix Summarization

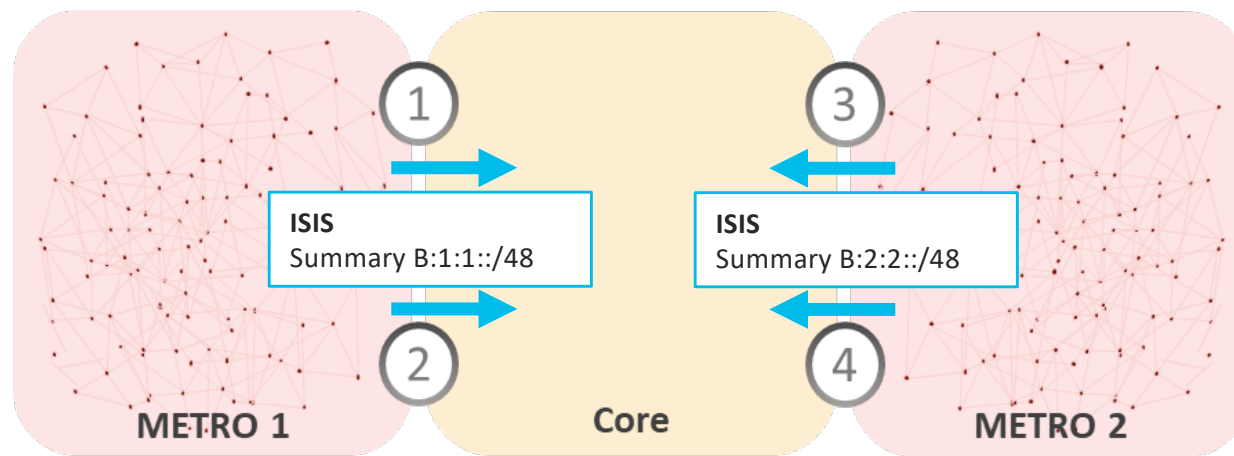

- Back to basic IP routing and summarization
- No BGP inter-AS Option A/B/C

SRv6 has excellent native Scale

- Many use-cases do not even use an SRH 😊
 - Any VPN (L3VPN, PW, eVPN)
 - Egress Peering Engineering
 - Low-Latency or Disjoint Slicing
 - Optimal Load-Balancing
- If SRH is needed, most cases will use 1 or 2 SID's
- Prefix Summarization gain
- Talk to the operators who deployed, they are happy to share experience

SRv6 NSO Automation

- Address allocation
 - Loopback and interfaces
- SID allocation
 - Algo 0 and Flex-Algos
- Multi-Domain
- ISIS summarization and redistribution between domains
- Latency Measurement
- Flex-Algo – Delay Slice
- TI-LFA
- BFD
- BGP-VPN

Negligible SRv6 SID block allocation - Iliad

As of the end of 2019, the SRv6 network consists of:

- o 1000 Cisco NCS 5500 routers.
- o 1800 Iliad's Nodeboxes.
- o The network services 4.5 million mobile subscribers (as of Q3 2019).
- o The network is carrying 300 Gbps of commercial traffic at peak hours.
- o It is expected to grow to more than 4000 Nodeboxes in 2020. The SRv6 SIDs are allocated from a /40 sub-block of FC/8.

Less than 1 billionth of the FC/8 space - Negligible

Negligible SRv6 SID block allocation - SBB

- SBB currently has a /20 public IPv6 space from APNIC
- SBB SRv6 is supported by a /40 sub-block
- This is only 1 millionth of the current SBB allocation

Micro-Program



A new set of (micro)-instructions

- Full leverage of SRH encapsulation
 - Zero extension
- Full leverage of SRv6 control-plane
 - Zero extension

Network Program

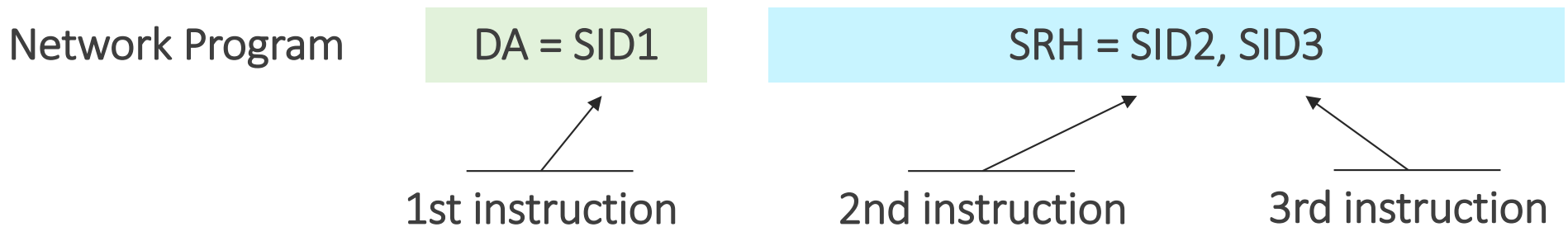

- A network program is a list of instructions (128-bit SRv6 SID)
- An instruction can be bound to any behavior
 - TE/FRR: END, END.X
 - VPN: END.DX, END.DT

Any instruction could hold a micro-program

Network Program

DA = SID1

1st instruction
carries a micro-
program

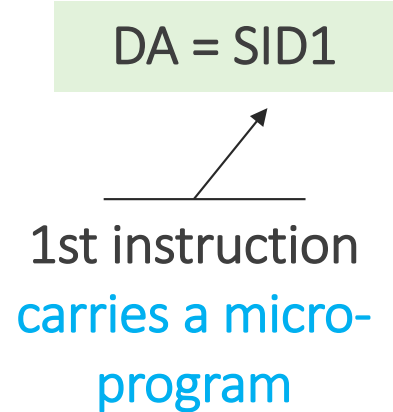

SRH = SID2, SID3

2nd instruction
carries a micro-
program

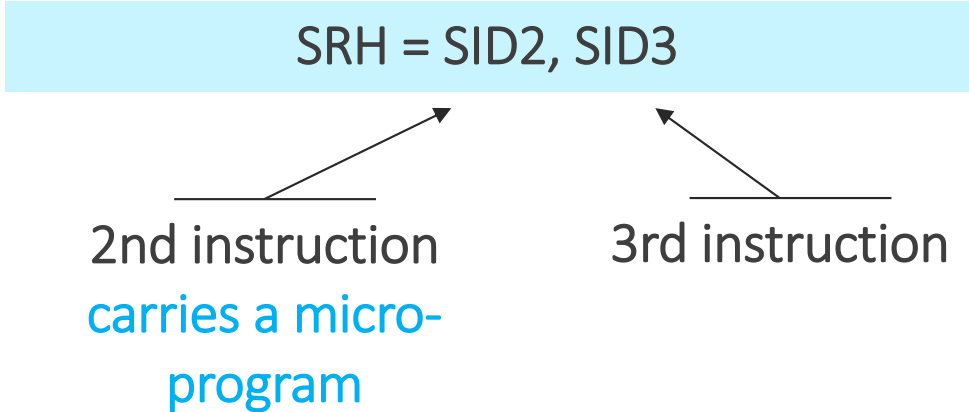

3rd instruction



Any instruction could hold a micro-program

Network Program

DA = SID1

1st instruction

SRH = SID2, SID3

2nd instruction
carries a micro-
program

3rd instruction
carries a micro-
program

Micro-Program in an SRv6 SID

SRv6 SID = 128 bits = 8 groups of 4 nibbles

Assuming an allocation block in /32 (B:B::/32)

Assuming a micro-instruction ID in 4 nibbles

B:B:uID1:uID2:uID3:uID4:uID5:uID6

6 micro instructions per SRv6 Instruction

Illustration: go to 8 then 7 then 2 and decaps

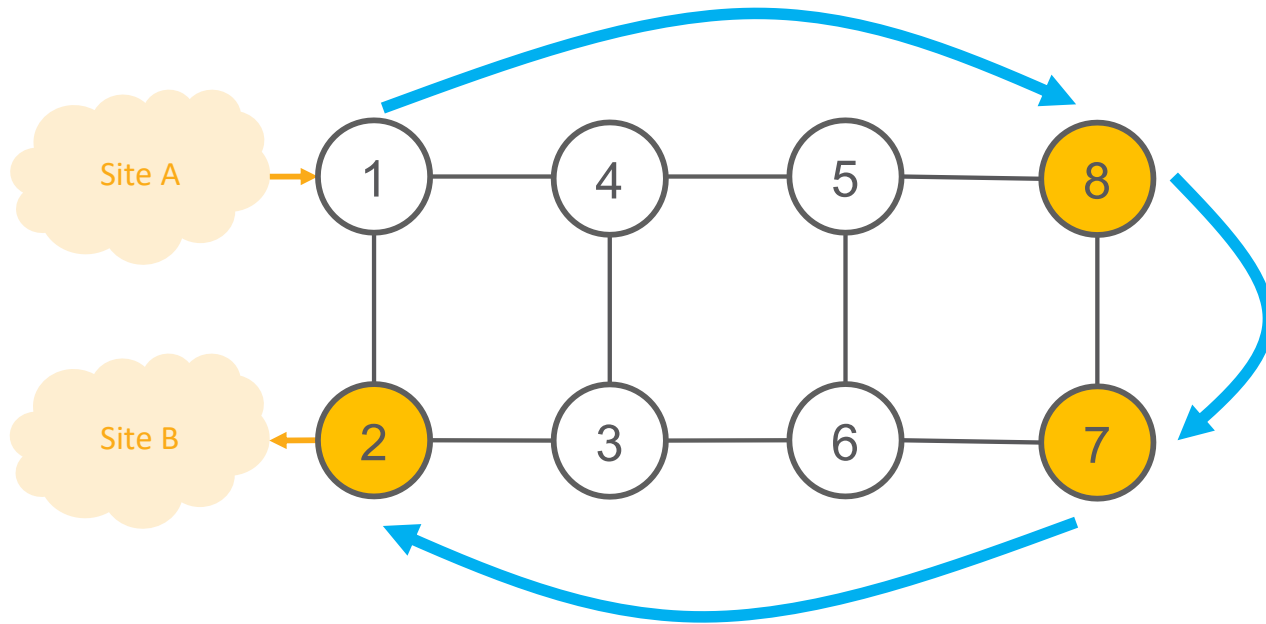

One single micro-program in the DA is enough

DA = **bbbb:bbbb:0800:0700:0200:0000:0000:0000**

Basic IP Routing: no new extension

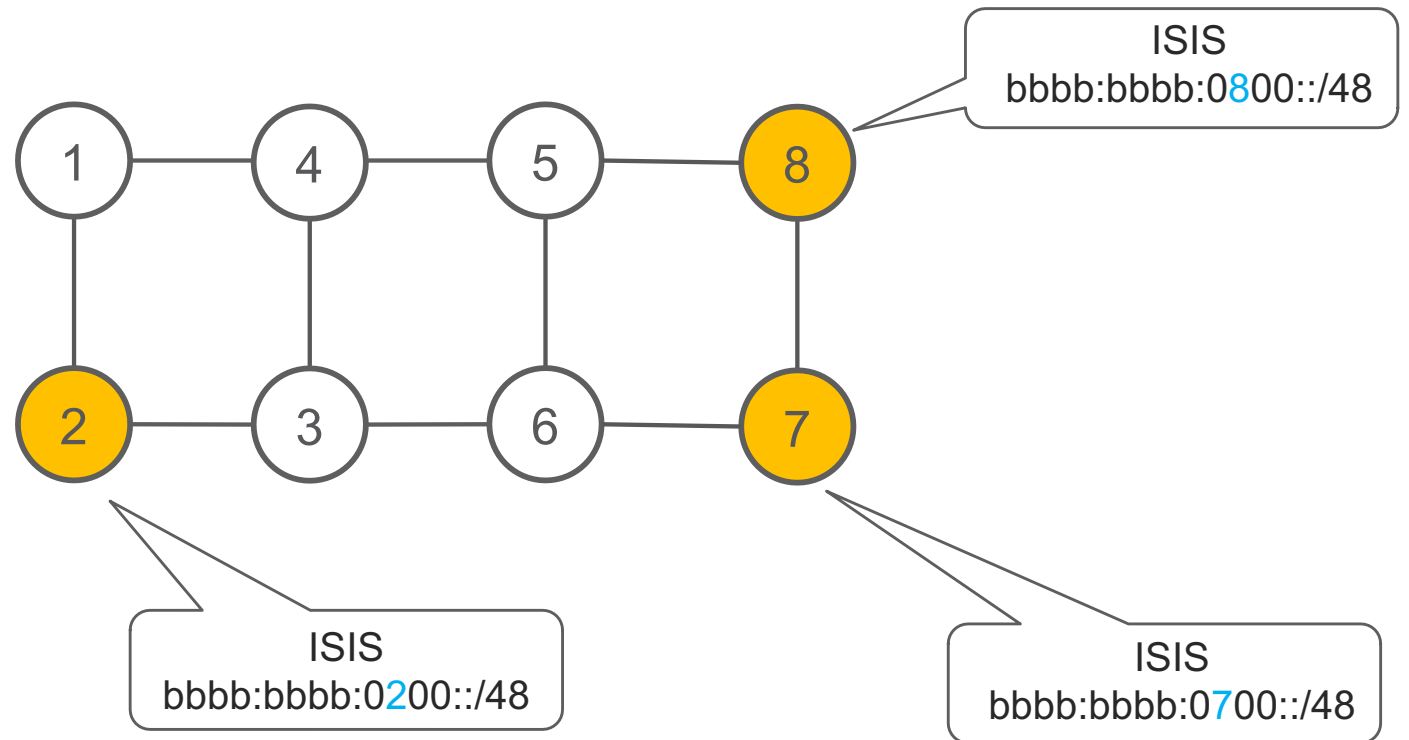

@1: basic IPv6

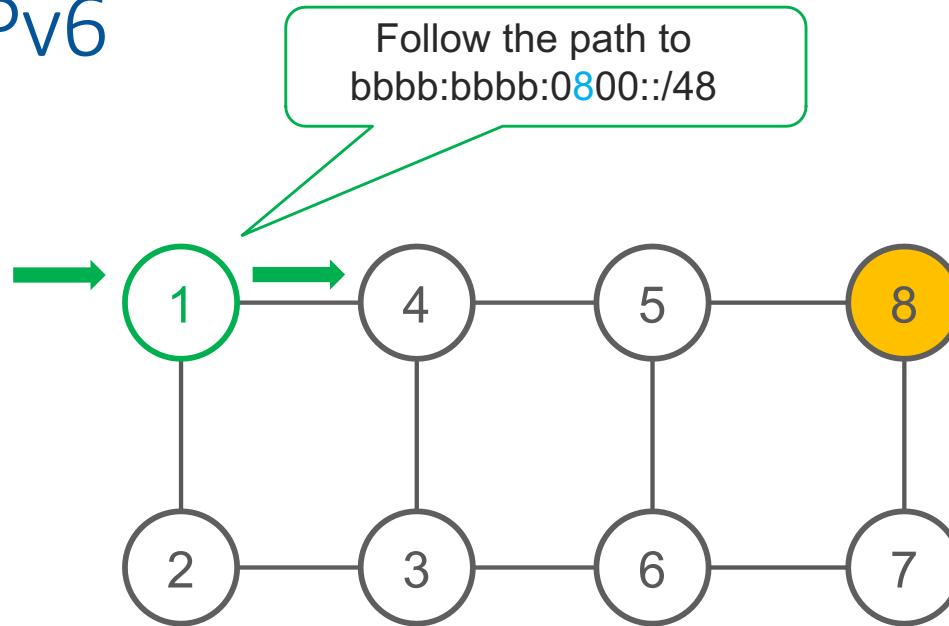

DA = bbbb:bbbb:0800:0700:0200:0000:0000:0000

@4: basic IPv6

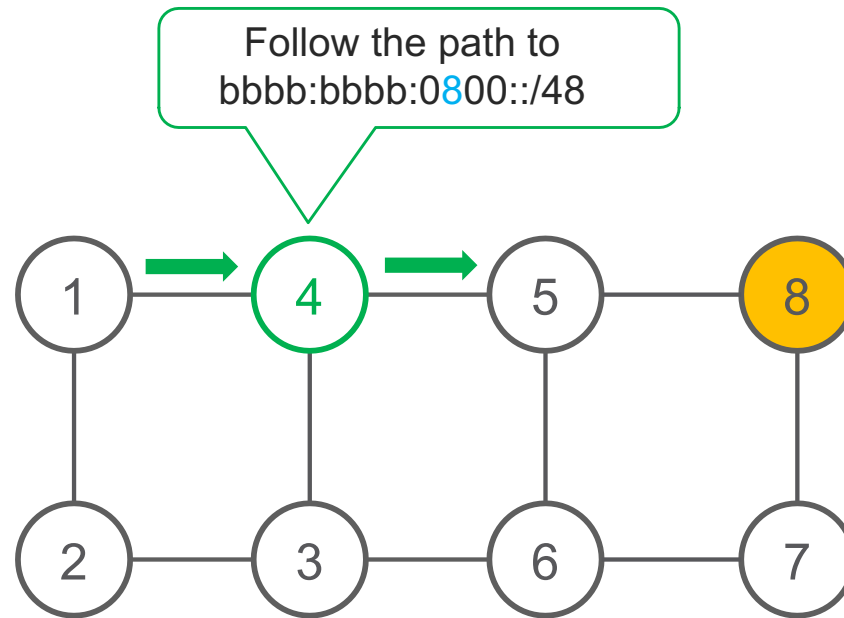

DA = bbbb:bbbb:0800:0700:0200:0000:0000:0000

@5: basic IPv6

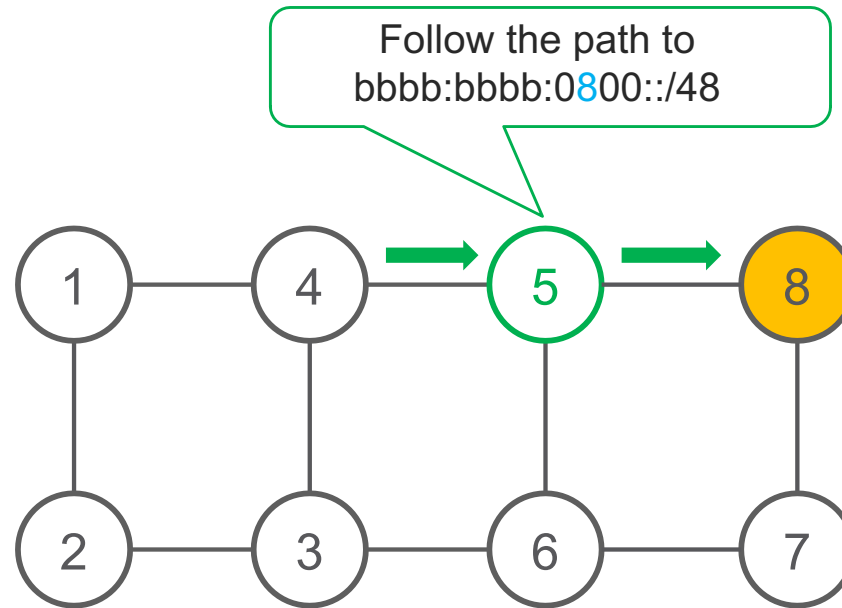

DA = **bbbb:bbbb:0800:0700:0200:0000:0000:0000**

@8: Shift and Forward

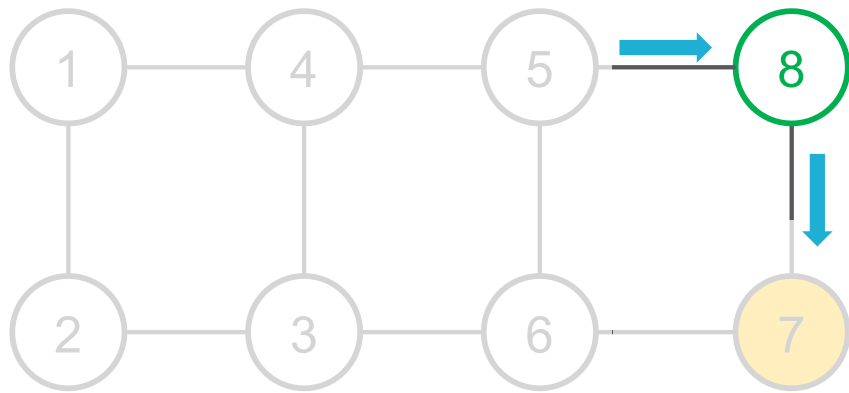

Rx'd DA: bbbb:bbbb:0800:0700:0200:0000:0000:0000

SHIFT << 16

Tx'd DA: bbbb:bbbb:0700:

bbbb:bbbb:0700::/48

FIB Longest-Match `bbbb:bbbb:0800::/48` → SRv6 Instruction:

Shift micro-Program by one micro-Instruction

Set last micro-instruction to "end of micro-program"

Lookup the updated DA and forward

@7: Shift and Forward

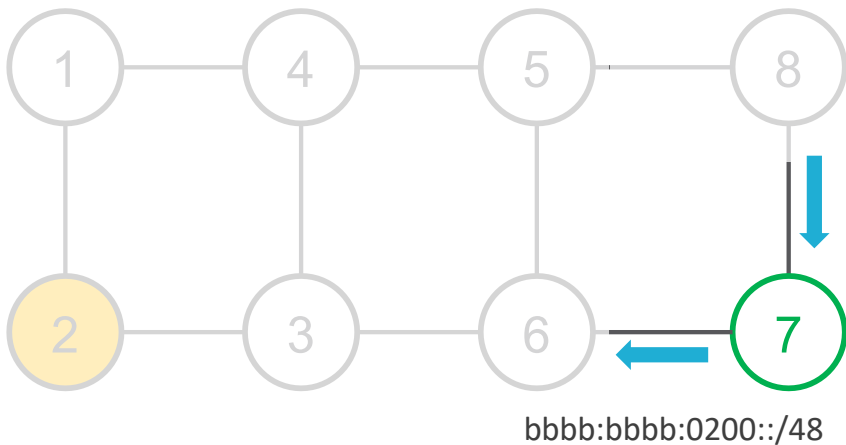

Rx'd DA: bbbb:bbbb:0700:0200:0000:0000:0000:0000

SHIFT << 16

Tx'd DA: bbbb:bbbb:0200:

FIB Longest-Match `bbbb:bbbb:0700::/48` → SRv6 Instruction:

Shift micro-Program by one micro-Instruction

Set last micro-instruction to "end of micro-program"

Lookup the updated DA and forward

@6: basic IPv6

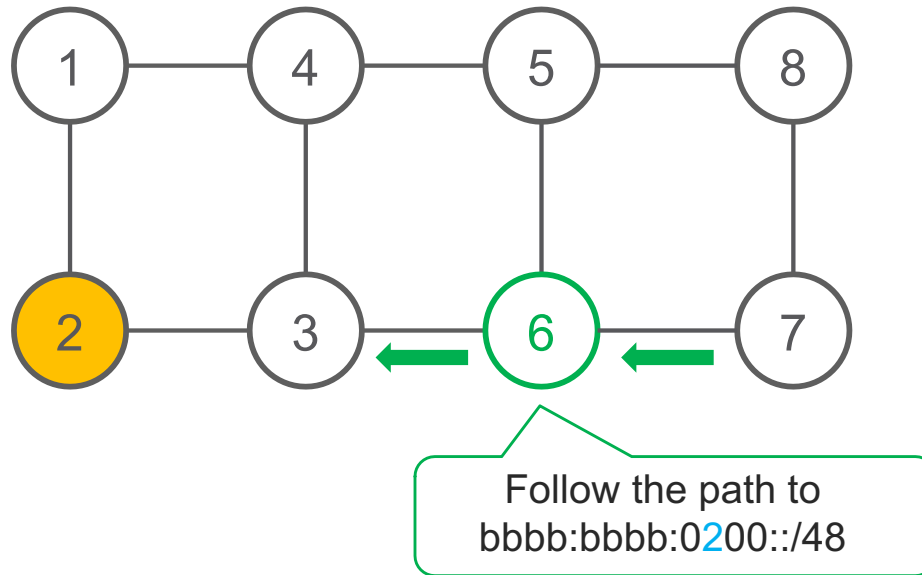

DA = **bbbb:bbbb:0200**:0000:0000:0000:0000:0000

@3: basic IPv6

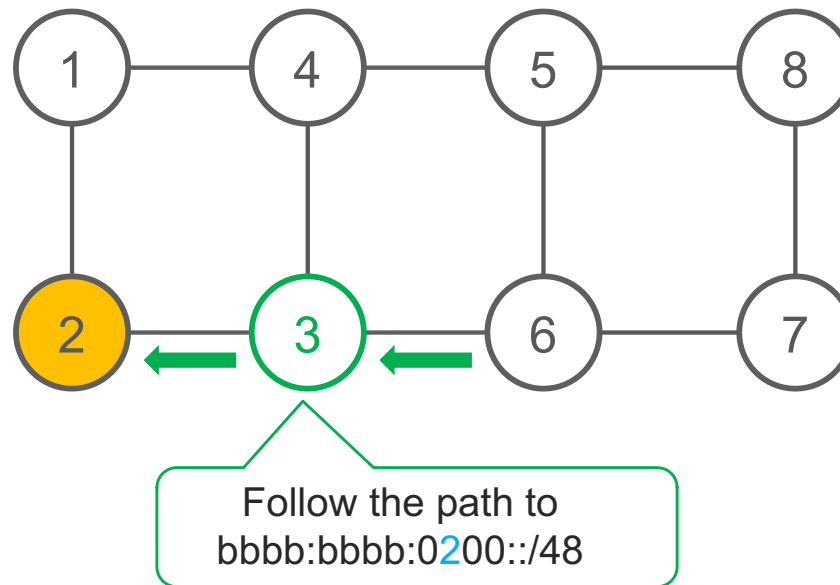

DA = **bbbb:bbbb:0200**:0000:0000:0000:0000:0000

@2: SRv6 End.DX4 behavior

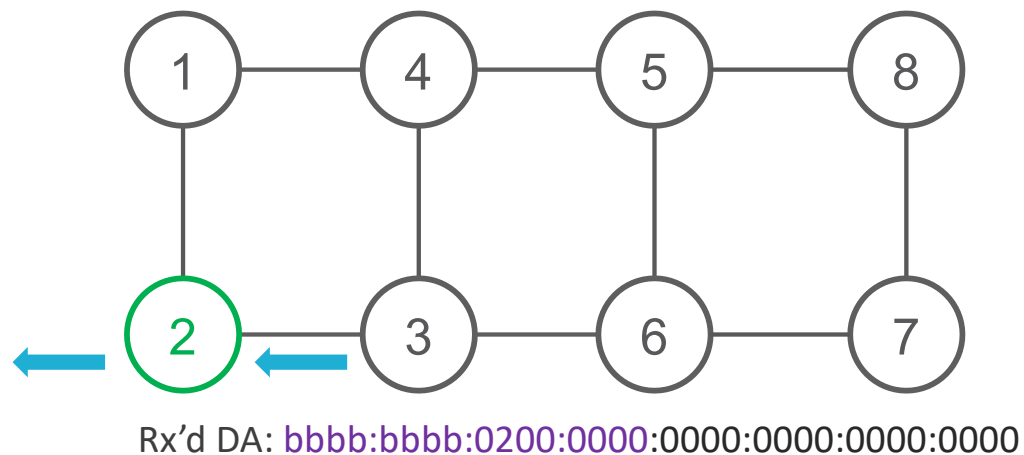

**FIB Longest-Match `bbbb:bbbb:0200:0000::/64` → SRv6 Instruction:
Decapsulate and cross-connect inner IPv4 packet to Site B**

Benefits

- Ultra-scalable for 5G deployment
 - 18 FRR, TE, NFV and VPN micro-instructions in only 40 byte SRH overhead
- Mathematically the best SRv6 compression solution
- Linerate for multi-Tbps hardware
 - Shift is a basic hardware logic
- Friendly to merchant silicon
 - Proven by endorsement and interop
- Friendly to legacy equipment

No Cost

- Full leverage (zero change) to SRv6
 - Net PGM model
 - SRH encapsulation
 - Control Plane
- Seamless Deployment on IPv6 host

Alibaba



- Dennis Cai reports successful milestone in January 2020
 - SRv6 micro-program linerate hardware verification in Cisco lab
 - Cisco 8000 series (silicon one), NCS-5500, ASR9k
- Use-case
 - Applications are already IPv6 enabled
 - Network is already IPv6-enabled
 - Seamless end-to-end SDN control from Apps through DC, Metro, Backbone

Bell Canada



- Dan Voyer reports successful milestone in January 2020
 - SRv6 micro-program linerate hardware verification
 - Cisco 8000 series (silicon one), NCS-5500, ASR9k, CRS-X
- Use-case: 5G with
 - Ultra Scale
 - Protocol simplification and IPv6 convergence
 - Integrated TE, FRR, Slicing, VPN and NFV for end-to-end value-added service
 - Optimum Load-Balancing
 - Legacy reuse, CRS-X

Network Topology

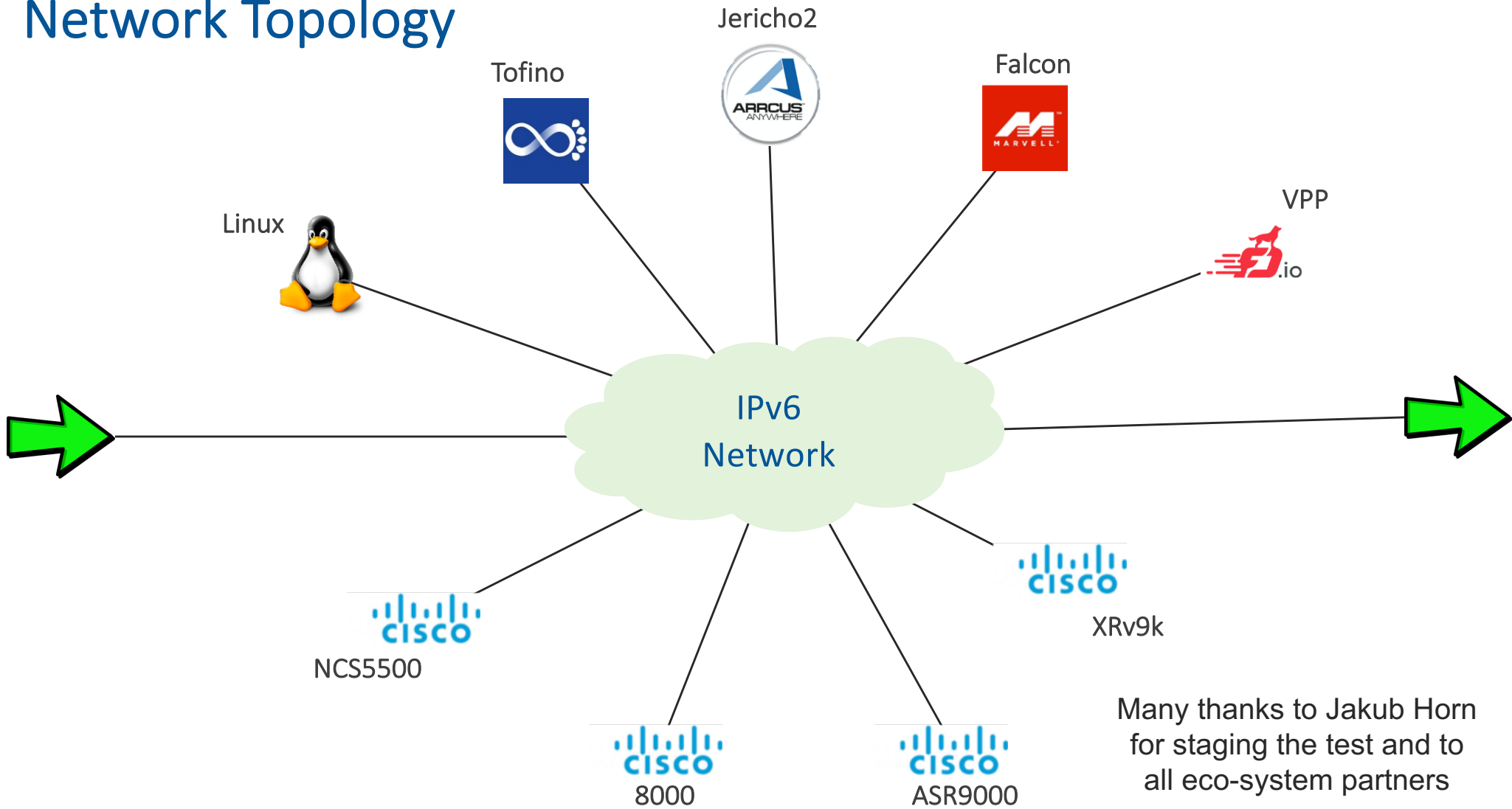

Many thanks to Jakub Horn for staging the test and to all eco-system partners

Conclusion

Simplicity Always Prevails



- ~~LDP~~
- ~~RSVP-TE~~
- ~~Inter-AS Option A/B/C~~
- ~~MPLS~~
- ~~UDP/VxLAN~~
- ~~NSH~~

Furthermore with more scale and functionality

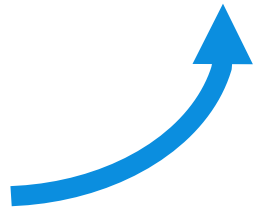

At record speed

- In 2019: 8 large-scale commercial deployments
 - Softbank, Iliad, China Telecom, LINE corporation, China Unicom, CERNET2, China Bank and Uganda MTN.
- 18 HW linerate implementations
 - Cisco Systems, Huawei
 - Broadcom, Barefoot, Intel, Marvell, Mellanox
 - Multiple Interop Reports
- 11 open-source platforms/ Applications
 - Linux, FD.io VPP, P4, Wireshark, tcpdump, iptables, nftables, snort, ExaBGP, Contiv-VPP

An extended recording
of this presentation is
available at

segment-routing.net/srv6-status/

Stay up-to-date

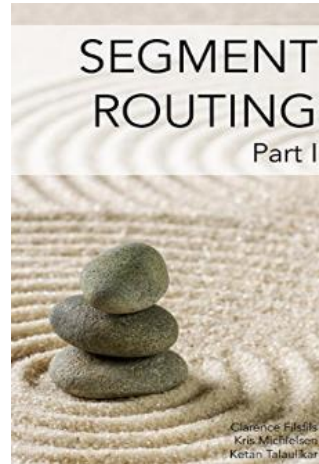

amzn.com/B01I58LSUO

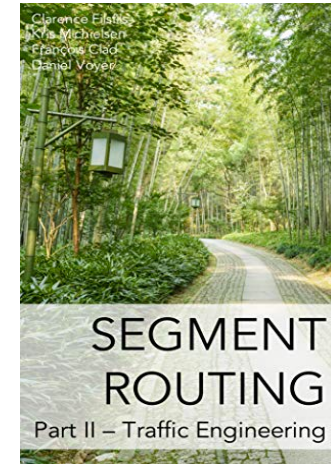

amazon.com/dp/B07N13RDM9



twitter.com/SegmentRouting



facebook.com/SegmentRouting/



segment-routing.net



linkedin.com/groups/8266623

Thank you!