

THE TRANSFER TEST

www.thetransfertest.com | info@thetransfertest.com

Revision Booklet 4 In Maths and English

Tasks	Completed <input checked="" type="checkbox"/>
Speed +	
Speed -	
Speed x	
Speed ÷	
Poetry Text	
Apostrophes	
Non-Fiction Text	
Homonyms	

Tasks	Completed <input checked="" type="checkbox"/>
2D Shape	
3D Shape	
3D Shape: True or False	
Nets	
Volume	
Angles	
Interior Angles	
Coordinates	

Suggested Guidance

Spend 5 minutes on the Speed Test.

Spend 15 minutes on the two Maths Topics.

Spend 10 minutes on the English Topic.

Total time spent: 30 minutes

Week 1	Week 2	Week 3	Week 4
Speed +	Speed -	Speed x	Speed ÷
2D Shape	3D Shape: True or False	Volume	Interior Angles
3D Shape	Nets	Angles	Coordinates
Poetry Text	Apostrophes	Non-Fiction Text	Homonyms

3
KEEPING SKILLS SHARP

ADDITION SPEED TEST

Use a timer.

Spend **five minutes** on this Speed Test.

Score out of 100: _____

$1 + 3 =$	$0 + 9 =$	$6 + 9 =$	$2 + 0 =$	$1 + 5 =$
$3 + 7 =$	$8 + 2 =$	$4 + 5 =$	$6 + 0 =$	$4 + 2 =$
$8 + 8 =$	$5 + 6 =$	$6 + 3 =$	$6 + 8 =$	$7 + 7 =$
$2 + 2 =$	$0 + 1 =$	$7 + 5 =$	$2 + 3 =$	$8 + 4 =$
$3 + 5 =$	$9 + 2 =$	$2 + 3 =$	$6 + 7 =$	$5 + 5 =$
$8 + 7 =$	$8 + 5 =$	$1 + 8 =$	$1 + 9 =$	$2 + 9 =$
$1 + 3 =$	$8 + 6 =$	$2 + 0 =$	$8 + 7 =$	$8 + 3 =$
$4 + 9 =$	$2 + 5 =$	$2 + 9 =$	$8 + 9 =$	$3 + 9 =$
$9 + 9 =$	$1 + 1 =$	$4 + 3 =$	$4 + 8 =$	$6 + 2 =$
$3 + 9 =$	$7 + 9 =$	$3 + 7 =$	$4 + 1 =$	$5 + 6 =$
$3 + 3 =$	$2 + 7 =$	$6 + 6 =$	$5 + 8 =$	$0 + 3 =$
$4 + 0 =$	$6 + 1 =$	$6 + 7 =$	$7 + 3 =$	$5 + 7 =$
$7 + 8 =$	$8 + 8 =$	$7 + 8 =$	$5 + 4 =$	$8 + 5 =$
$8 + 7 =$	$9 + 9 =$	$0 + 5 =$	$6 + 9 =$	$1 + 7 =$
$9 + 5 =$	$4 + 4 =$	$6 + 5 =$	$5 + 9 =$	$7 + 5 =$
$6 + 4 =$	$6 + 8 =$	$7 + 9 =$	$8 + 9 =$	$0 + 7 =$
$8 + 6 =$	$9 + 7 =$	$8 + 6 =$	$4 + 7 =$	$9 + 6 =$
$7 + 9 =$	$8 + 0 =$	$9 + 4 =$	$9 + 8 =$	$8 + 4 =$
$5 + 5 =$	$9 + 8 =$	$8 + 1 =$	$9 + 6 =$	$4 + 6 =$
$9 + 2 =$	$12 + 5 =$	$10 + 3 =$	$13 + 6 =$	$11 + 4 =$

KEEPING SKILLS SHARP

SUBTRACTION SPEED TEST

Use a timer.

Spend **five minutes** on this Speed Test.

Score out of 100: _____

$0 - 0 =$	$6 - 1 =$	$7 - 3 =$	$1 - 1 =$	$8 - 3 =$
$9 - 5 =$	$2 - 1 =$	$9 - 4 =$	$9 - 9 =$	$4 - 0 =$
$2 - 0 =$	$10 - 6 =$	$5 - 4 =$	$5 - 0 =$	$6 - 5 =$
$6 - 2 =$	$3 - 0 =$	$3 - 1 =$	$7 - 6 =$	$9 - 7 =$
$10 - 5 =$	$2 - 1 =$	$3 - 3 =$	$7 - 2 =$	$6 - 3 =$
$6 - 5 =$	$8 - 4 =$	$5 - 1 =$	$4 - 1 =$	$12 - 9 =$
$12 - 7 =$	$7 - 4 =$	$5 - 2 =$	$4 - 4 =$	$11 - 8 =$
$8 - 7 =$	$5 - 2 =$	$11 - 6 =$	$8 - 5 =$	$3 - 2 =$
$14 - 9 =$	$9 - 8 =$	$12 - 9 =$	$6 - 6 =$	$8 - 6 =$
$5 - 5 =$	$9 - 6 =$	$4 - 3 =$	$10 - 7 =$	$13 - 9 =$
$12 - 8 =$	$2 - 2 =$	$11 - 7 =$	$13 - 8 =$	$7 - 3 =$
$11 - 2 =$	$17 - 9 =$	$10 - 1 =$	$8 - 8 =$	$4 - 2 =$
$7 - 5 =$	$5 - 3 =$	$9 - 9 =$	$9 - 3 =$	$9 - 0 =$
$8 - 2 =$	$6 - 4 =$	$14 - 5 =$	$6 - 0 =$	$10 - 6 =$
$12 - 6 =$	$13 - 4 =$	$6 - 4 =$	$17 - 9 =$	$15 - 4 =$
$16 - 5 =$	$7 - 1 =$	$13 - 7 =$	$11 - 5 =$	$7 - 7 =$
$16 - 8 =$	$17 - 3 =$	$13 - 3 =$	$17 - 8 =$	$14 - 5 =$
$18 - 9 =$	$13 - 7 =$	$10 - 4 =$	$12 - 3 =$	$18 - 9 =$
$15 - 6 =$	$19 - 7 =$	$13 - 2 =$	$16 - 7 =$	$16 - 3 =$
$14 - 3 =$	$12 - 4 =$	$17 - 5 =$	$14 - 6 =$	$18 - 7 =$

5
KEEPING SKILLS SHARP
MULTIPLICATION SPEED TEST

Use a timer.

Spend **five minutes** on this Speed Test.

Score out of 100: _____

9 X 1 =	8 X 1 =	0 X 0 =	4 X 3 =	2 X 1 =
7 X 2 =	4 X 2 =	9 X 2 =	1 X 1 =	3 X 3 =
8 X 4 =	0 X 1 =	5 X 1 =	3 X 9 =	6 X 2 =
0 X 5 =	7 X 1 =	3 X 2 =	5 X 5 =	1 X 5 =
5 X 3 =	2 X 9 =	3 X 4 =	0 X 2 =	6 X 4 =
1 X 2 =	6 X 3 =	0 X 6 =	8 X 3 =	1 X 7 =
7 X 3 =	4 X 1 =	5 X 4 =	2 X 5 =	3 X 1 =
6 X 7 =	0 X 3 =	1 X 6 =	7 X 4 =	0 X 4 =
3 X 5 =	4 X 9 =	8 X 2 =	2 X 8 =	4 X 4 =
7 X 5 =	6 X 1 =	2 X 2 =	1 X 3 =	2 X 4 =
1 X 8 =	2 X 7 =	3 X 6 =	6 X 6 =	4 X 6 =
8 X 5 =	5 X 6 =	7 X 6 =	0 X 7 =	5 X 2 =
1 X 4 =	2 X 3 =	3 X 8 =	8 X 6 =	2 X 6 =
4 X 5 =	6 X 5 =	7 X 7 =	1 X 9 =	4 X 8 =
5 X 8 =	0 X 8 =	4 X 7 =	9 X 9 =	3 X 7 =
7 X 9 =	8 X 7 =	6 X 8 =	5 X 7 =	9 X 3 =
9 X 5 =	9 X 12 =	9 X 4 =	0 X 9 =	8 X 9 =
9 X 8 =	5 X 9 =	7 X 8 =	8 X 12 =	9 X 7 =
8 X 8 =	7 X 12 =	9 X 6 =	6 X 12 =	6 X 9 =
11 X 3 =	9 X 6 =	4 X 12 =	8 X 7 =	5 X 12 =

KEEPING SKILLS SHARP

DIVISION SPEED TEST

Use a timer.

Spend **five minutes** on this Speed Test.

Score out of 100: _____

$10 \div 5 =$	$4 \div 4 =$	$4 \div 1 =$	$3 \div 3 =$	$8 \div 2 =$
$24 \div 3 =$	$0 \div 0 =$	$18 \div 3 =$	$20 \div 5 =$	$0 \div 4 =$
$10 \div 2 =$	$6 \div 3 =$	$27 \div 3 =$	$2 \div 1 =$	$4 \div 2 =$
$8 \div 4 =$	$6 \div 2 =$	$0 \div 1 =$	$15 \div 5 =$	$36 \div 4 =$
$0 \div 7 =$	$5 \div 1 =$	$12 \div 4 =$	$9 \div 3 =$	$0 \div 6 =$
$40 \div 4 =$	$2 \div 2 =$	$1 \div 1 =$	$32 \div 4 =$	$30 \div 3 =$
$21 \div 3 =$	$0 \div 2 =$	$5 \div 5 =$	$12 \div 2 =$	$25 \div 5 =$
$12 \div 3 =$	$35 \div 5 =$	$7 \div 1 =$	$16 \div 4 =$	$28 \div 4 =$
$3 \div 1 =$	$12 \div 6 =$	$30 \div 5 =$	$18 \div 6 =$	$0 \div 3 =$
$35 \div 7 =$	$0 \div 5 =$	$15 \div 3 =$	$6 \div 6 =$	$40 \div 5 =$
$24 \div 4 =$	$50 \div 5 =$	$28 \div 7 =$	$0 \div 8 =$	$6 \div 1 =$
$24 \div 6 =$	$21 \div 7 =$	$60 \div 5 =$	$7 \div 7 =$	$42 \div 7 =$
$45 \div 5 =$	$44 \div 4 =$	$20 \div 4 =$	$8 \div 1 =$	$55 \div 5 =$
$54 \div 6 =$	$0 \div 9 =$	$24 \div 8 =$	$27 \div 9 =$	$8 \div 8 =$
$14 \div 7 =$	$16 \div 8 =$	$48 \div 6 =$	$49 \div 7 =$	$9 \div 1 =$
$80 \div 8 =$	$30 \div 6 =$	$64 \div 8 =$	$9 \div 9 =$	$40 \div 8 =$
$48 \div 8 =$	$18 \div 9 =$	$36 \div 9 =$	$36 \div 6 =$	$45 \div 9 =$
$42 \div 6 =$	$56 \div 7 =$	$32 \div 8 =$	$108 \div 9 =$	$60 \div 6 =$
$96 \div 8 =$	$54 \div 9 =$	$56 \div 8 =$	$63 \div 7 =$	$63 \div 9 =$
$72 \div 6 =$	$70 \div 7 =$	$72 \div 9 =$	$84 \div 7 =$	$72 \div 8 =$

MAKE SURE YOU HAVE LEARNED THE INFORMATION ON THIS PAGE BEFORE TRYING THE QUESTIONS.

Parallel Lines

Lines that never cross are called parallel lines.

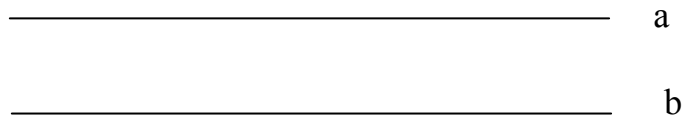

Line **a** is **parallel** to line **b**.

Intersecting Lines

Lines that cross are called intersecting lines.

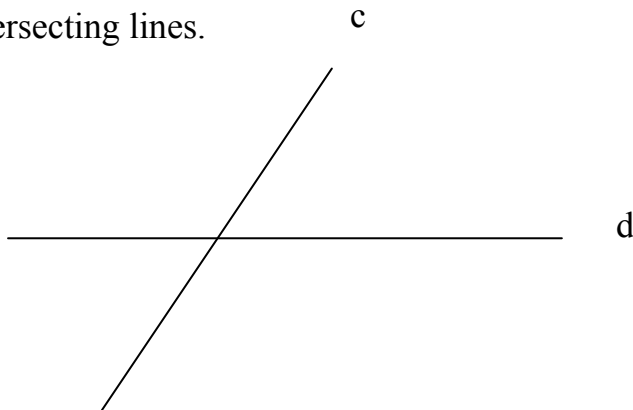

Line **c** intersects line **d**.

Perpendicular Lines

Lines that intersect at right angles are called perpendicular lines.

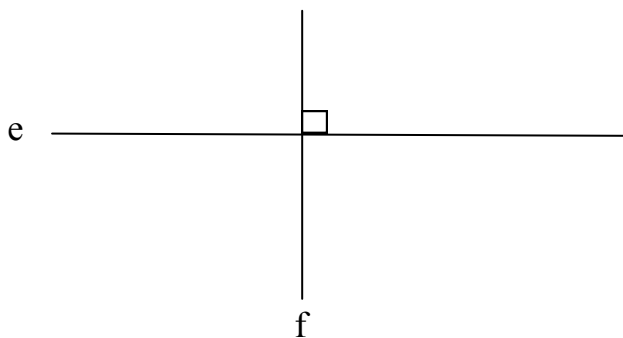

Line **e** is **perpendicular** to line **f**.

1. Look at the lines marked **h**, **i**, **j**, **k**, **l** and **m** drawn in the figure below.

Line **h** is **parallel** to line **j**.

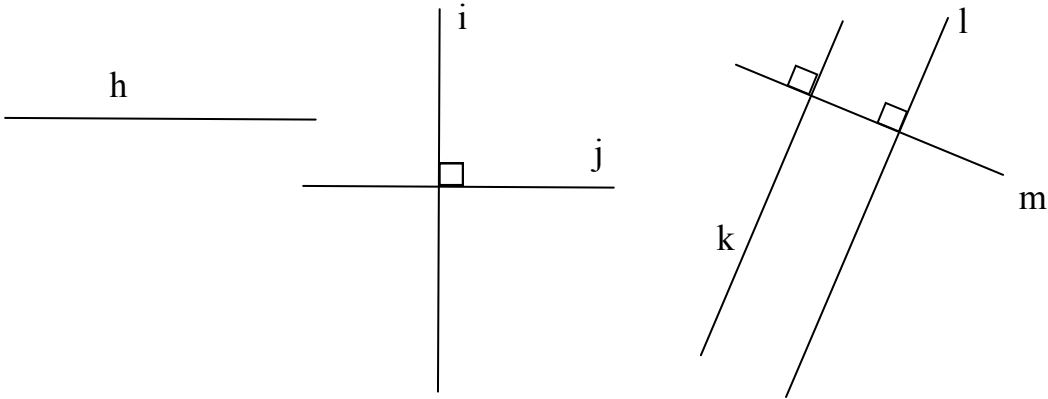

Tick each of the statements below true or false.

	True	False
Line m is perpendicular to line k	<input type="checkbox"/>	<input type="checkbox"/>
Line i is parallel to line m	<input type="checkbox"/>	<input type="checkbox"/>
Line k is perpendicular to line m	<input type="checkbox"/>	<input type="checkbox"/>
Line j is perpendicular to line i	<input type="checkbox"/>	<input type="checkbox"/>

2. Look at the three statements below. Tick each statement true or false.

	True	False
A rhombus has four 90° angles	<input type="checkbox"/>	<input type="checkbox"/>
The three angles of a triangle add to make 180°	<input type="checkbox"/>	<input type="checkbox"/>
Opposite angles are equal in a parallelogram	<input type="checkbox"/>	<input type="checkbox"/>

(7)

3. The figure below shows 4 lines **r**, **s**, **t** and **u**.

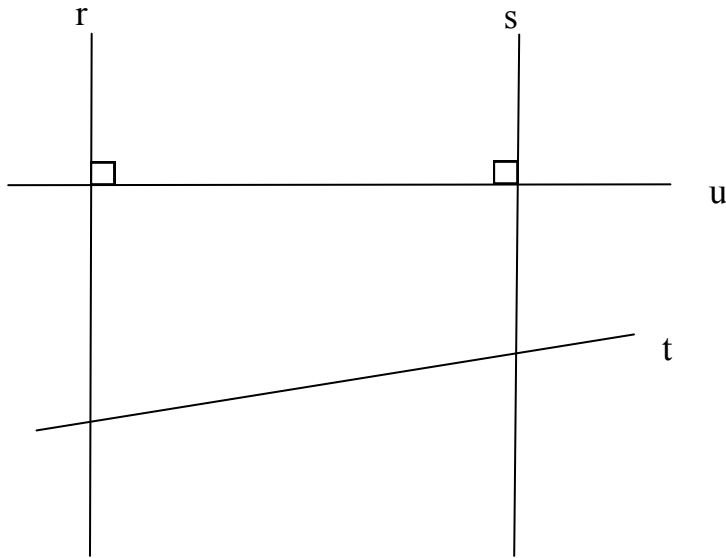

Tick each of the statements below true or false.





	True	False
Line s is parallel to line r	<input type="checkbox"/>	<input type="checkbox"/>
Line t is parallel to line u	<input type="checkbox"/>	<input type="checkbox"/>
Line t is perpendicular to line r	<input type="checkbox"/>	<input type="checkbox"/>
Line u is perpendicular to line s	<input type="checkbox"/>	<input type="checkbox"/>

4. Look at the three statements below. Tick each statement true or false.

	True	False
A square has four 60° angles	<input type="checkbox"/>	<input type="checkbox"/>
A scalene triangle has two sides of equal length	<input type="checkbox"/>	<input type="checkbox"/>
A hexagon has 6 sides	<input type="checkbox"/>	<input type="checkbox"/>

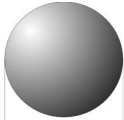
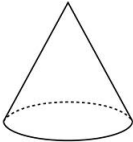
10
3D Shape

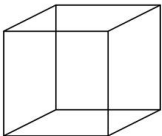
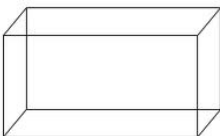
MAKE SURE YOU HAVE LEARNED THE INFORMATION ON THIS PAGE BEFORE TRYING THE QUESTIONS.

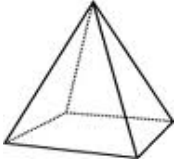
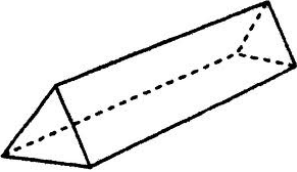
Shape	Name	Faces	Edges	Vertices
	Sphere	1	0	0
	Cone	2	1	1
	Cylinder	3	2	0
	Cube	6	12	8
	Cuboid	6	12	8
	Triangle-based pyramid	4	6	4
	Square-based pyramid	5	8	5
	Triangular prism	5	9	6

A **vertex** is a corner.

An **edge** joins one vertex with another.

A **face** is an individual surface and can be flat or curved.

1. Look at the **square-based pyramid** below.

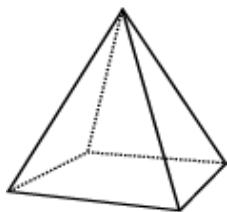

Complete the table below to show the number of **faces**, **edges** and **vertices** in the pyramid. Write your answers in the boxes below.

Faces	Edges	Vertices

Look at the cuboid below. Its dimensions are **8 cm** by **7 cm** by **3 cm**.

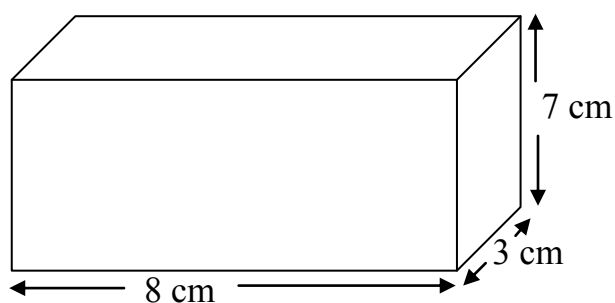

2. What is the **total length of all the edges** of the cuboid?

Write your answer in the space below.

_____ cm

3. The cuboid has six faces. What is the **area of the face** with the **largest** area? Write your answer in the space below.

_____ cm²

4. Look at the **cone** below.

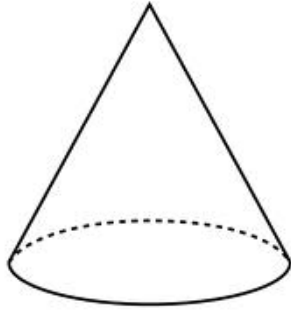

Complete the table below to show the number of **faces, edges and vertices** in the cone. Write your answers in the boxes below.

Faces	Edges	Vertices

5. Look at the **triangular prism** below.

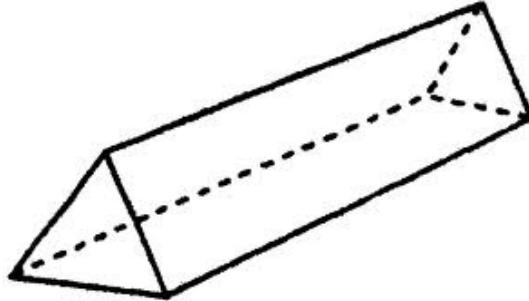

Complete the table below to show the number of **faces, edges and vertices** in the triangular prism. Write your answers in the boxes below.

Faces	Edges	Vertices

Poetry Text

All through the winter, long and cold,
 Dear Minnie every morning fed
 The little sparrows, pert and bold,
 And robins, with their breasts so red.

She loved to see the little birds
 Come fluttering to the window pane,
 In answer to the gentle words
 With which she scattered crumbs and grain.

One robin, bolder than the rest,
 Would perch upon her finger fair,
 And this of all she loved the best,
 And daily fed with tenderest care.

But one sad morn', when Minnie came,
 Her precious little pet she found,
 Not hopping, when she called his name,
 But lying dead upon the ground.

Anonymous

-
1. In the final verse the word **morn'** is used. Write the word without the apostrophe and using all its letters. Write your answer in the space below.

	(1)

2. Write the words below in **alphabetical order** in the spaces provided. The first one has been done for you.

robin round rot rolling rod

robin

3. Which **line** of the **third verse** of the poem tells us that Minnie **lovingly gave the robin food every day**? Write the line in the space below.

4. Look at the **three statements** below. **Based on your reading of the poem**, tick the correct box to show whether each statement is **true** or **false**.

	True	False
She found her sparrow lying dead on the ground	<input type="checkbox"/>	<input type="checkbox"/>
Minnie spoke kindly to them when she gave them food	<input type="checkbox"/>	<input type="checkbox"/>
Minnie fed the birds at the coldest time of year	<input type="checkbox"/>	<input type="checkbox"/>

5. Which of these words best describes the poem? Tick the best answer.

Serious

Humorous

Depressing

Exciting

	(4)

MAKE SURE YOU HAVE LEARNED THE INFORMATION ON THIS PAGE BEFORE TRYING THE QUESTIONS.

TOP TIP:

REVISE THE INFORMATION ABOUT 3D SHAPES BEFORE TRYING THE FOLLOWING QUESTIONS.

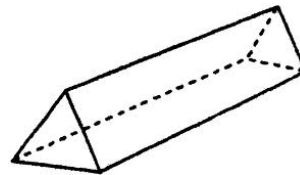
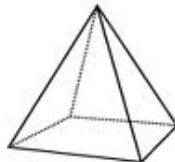
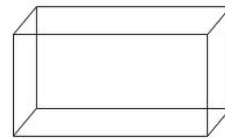
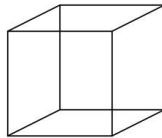
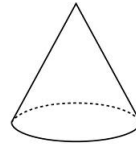
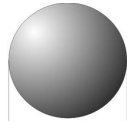

1. The statements below are about three dimensional solid objects.

Tick each of the statements below **true or false**.

	True	False
A cone has 1 face	<input type="checkbox"/>	<input type="checkbox"/>
A cuboid has 12 edges	<input type="checkbox"/>	<input type="checkbox"/>
A cube has 6 faces	<input type="checkbox"/>	<input type="checkbox"/>
A triangular prism has 9 vertices	<input type="checkbox"/>	<input type="checkbox"/>

2. The statements below are about three dimensional solid objects.

Tick each of the statements below **true or false**.

	True	False
A sphere has 1 curved face	<input type="checkbox"/>	<input type="checkbox"/>
A cylinder has 2 vertices	<input type="checkbox"/>	<input type="checkbox"/>
A triangle-based pyramid has 5 faces	<input type="checkbox"/>	<input type="checkbox"/>
A triangular prism has 6 edges	<input type="checkbox"/>	<input type="checkbox"/>

3. The statements below are about three dimensional solid objects.

Tick each of the statements below **true or false**.

	True	False
A cuboid has 8 vertices	<input type="checkbox"/>	<input type="checkbox"/>
A cube has 6 edges	<input type="checkbox"/>	<input type="checkbox"/>
A sphere has no edges	<input type="checkbox"/>	<input type="checkbox"/>
A cone has 1 vertex	<input type="checkbox"/>	<input type="checkbox"/>

4. The statements below are about three dimensional solid objects.

Tick each of the statements below **true or false**.

	True	False
A triangular prism has 5 faces	<input type="checkbox"/>	<input type="checkbox"/>
A cylinder has 2 edges	<input type="checkbox"/>	<input type="checkbox"/>
A cuboid has 8 faces	<input type="checkbox"/>	<input type="checkbox"/>
A cylinder has no edges	<input type="checkbox"/>	<input type="checkbox"/>

5. The statements below are about three dimensional solid objects.

Tick each of the statements below **true or false**.

	True	False
A cylinder has 2 faces	<input type="checkbox"/>	<input type="checkbox"/>
A triangle-based pyramid has 5 vertices	<input type="checkbox"/>	<input type="checkbox"/>
A cone has 1 edge	<input type="checkbox"/>	<input type="checkbox"/>
A square-based pyramid has 5 vertices	<input type="checkbox"/>	<input type="checkbox"/>

6. The statements below are about three dimensional solid objects.

Tick each of the statements below **true or false**.

	True	False
A sphere has no vertices	<input type="checkbox"/>	<input type="checkbox"/>
A triangle-based pyramid has 6 edges	<input type="checkbox"/>	<input type="checkbox"/>
A cube has 6 vertices	<input type="checkbox"/>	<input type="checkbox"/>
A square-based pyramid has 7 edges	<input type="checkbox"/>	<input type="checkbox"/>

MAKE SURE YOU HAVE LEARNED THE INFORMATION ON THIS PAGE BEFORE TRYING THE QUESTIONS.

A **net** is the **2D pattern** that creates the 3D shape.

Think about taking apart a box so it is flat. This would be the net.

The Net of a Cube

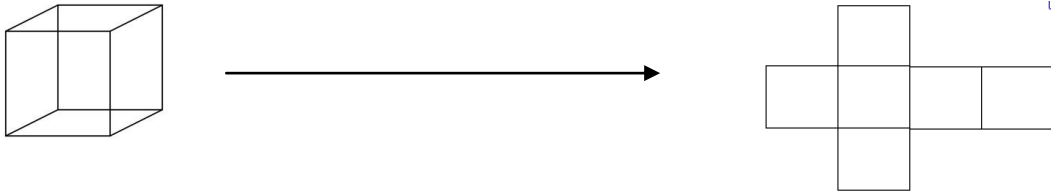

The Net of a Cuboid

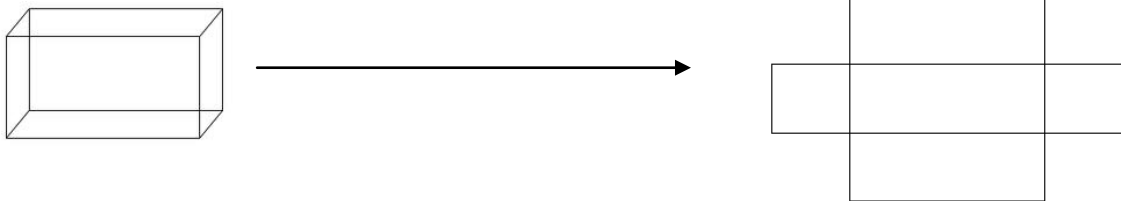

The Net of a Triangle-based Pyramid

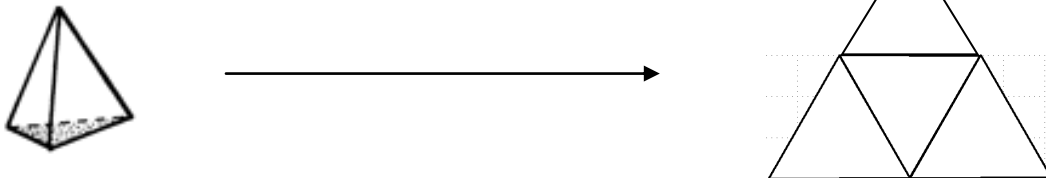

The Net of a Square-based Pyramid

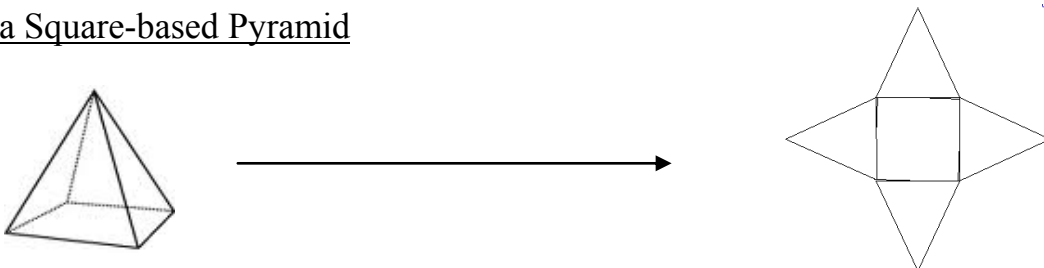

The Net of a Triangular Prism

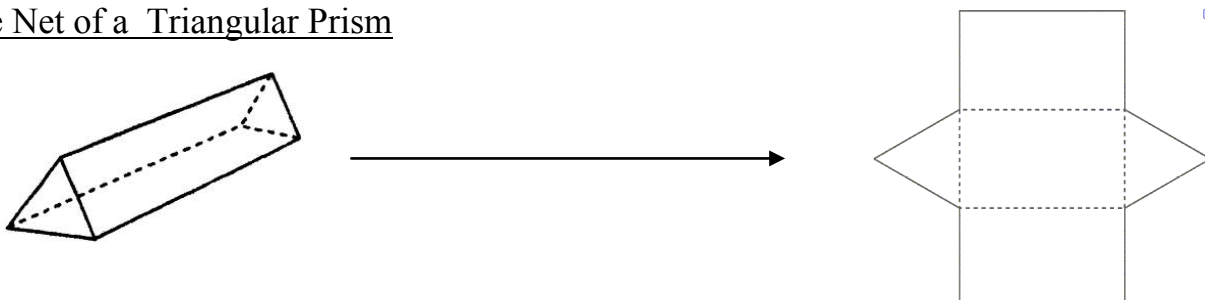

1. A net of a cube can be folded to make a cube. Look at the four figures below. Circle the **two** figures that are nets of a cube.

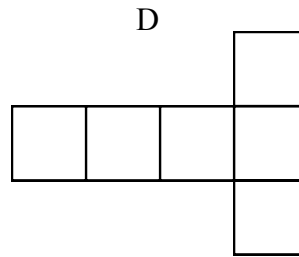
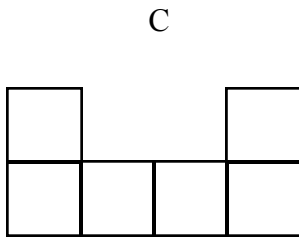
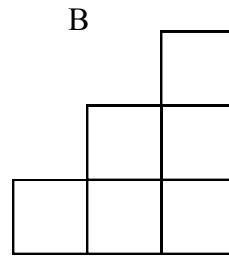
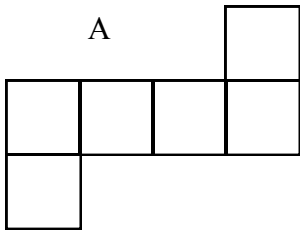

2. Two of the four figures below **could** be the **net** of a **triangular prism**. Circle the 2 figures that could be nets of triangular prisms.

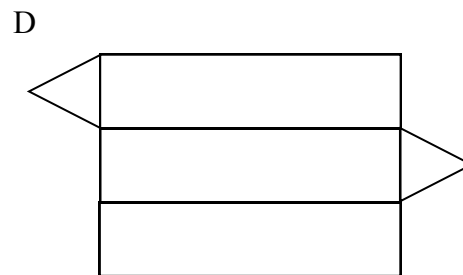
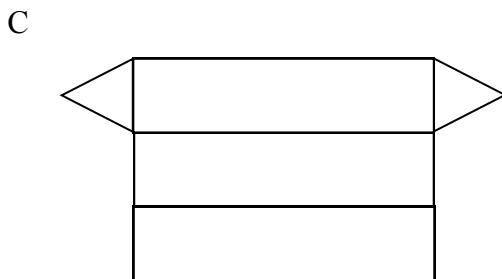
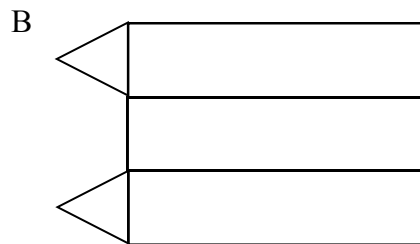
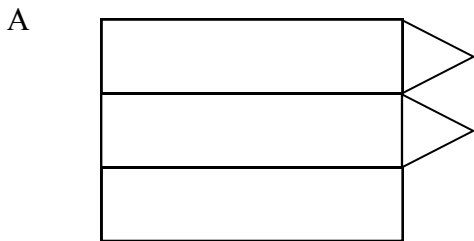

3. A net of a cuboid can be folded to make a cuboid. Look at the four figures below. Circle the **two** figures that are nets of a cuboid.

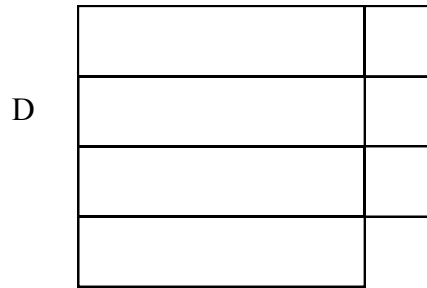
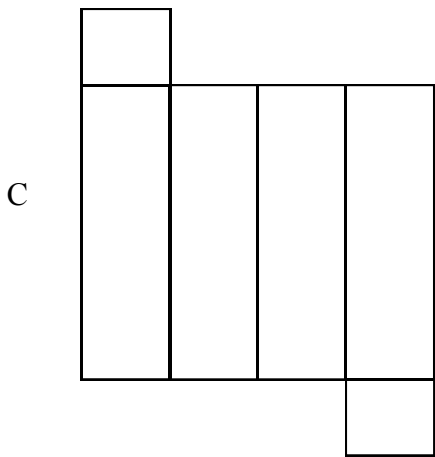
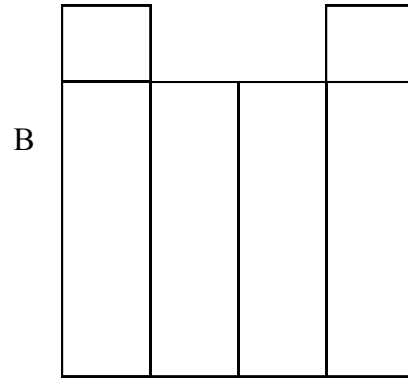

4. Identify the nets. Write your answers in the spaces provided.

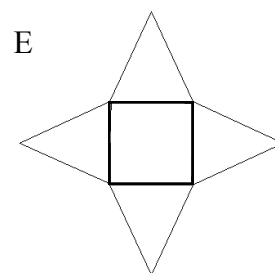
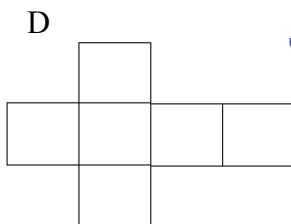
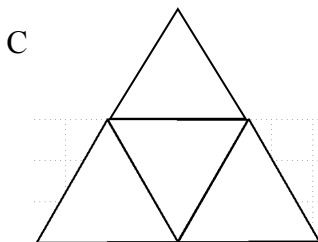
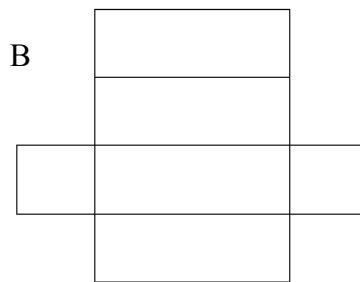
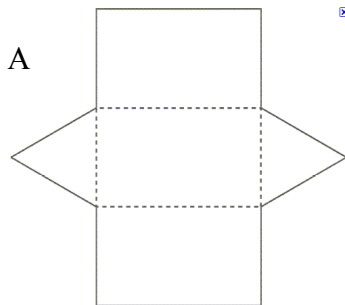

21
Apostrophes

MAKE SURE YOU HAVE LEARNED THE INFORMATION ON THIS PAGE BEFORE TRYING THE QUESTIONS.

Apostrophes are used in contractions (the shortened form of words, where some letters have been left out).

The apostrophe always goes where the letters have been left out.

I am	I'm	I will / I shall	I'll
you are	you're	you will / you shall	you'll
he is	he's	he will / he shall	he'll
she is	she's	she will / she shall	she'll
we are	we're	we will / we shall	we'll
they are	they're	they will / they shall	they'll
it is	it's	it will / it shall	it'll

I have	I've	I would / I had	I'd
you have	you've	you would / you had	you'd
he has	he's	he would / he had	he'd
she has	she's	she would / she had	she'd
we have	we've	we would / we had	we'd
they have	they've	they would / had	they'd
it has	it's	it would / it had	it'd

1. Write the contraction (shortened form of the words) for each of the pairs of words below. Remember to write an apostrophe.

I have _____

it will _____

he would _____

2. The words below are contractions. Write the two words that the contraction is formed from in the space below.

I'm _____

I'll _____

you've _____

3. Write the contraction (shortened form of the words) for each of the pairs of words below. Remember to write an apostrophe.

I would _____

you are _____

it has _____

4. The words below are contractions. Write the two words that the contraction is formed from in the space below.

he's _____

you'll _____

you 'd _____

5. Write the contraction (shortened form of the words) for each of the pairs of words below. Remember to write an apostrophe.

she has _____

she will _____

it is _____

6. The words below are contractions. Write the two words that the contraction is formed from in the space below.

they'll _____

we're _____

they've _____

7. Write the contraction (shortened form of the words) for each of the pairs of words below. Remember to write an apostrophe.

we will _____

she is _____

we have _____

8. The words below are contractions. Write the two words that the contraction is formed from in the space below.

he's _____

they're _____

he'll _____

MAKE SURE YOU HAVE LEARNED THE INFORMATION ON THIS PAGE BEFORE TRYING THE QUESTIONS.

Volume is the amount of space a solid shape takes up.

To calculate the volume of a shape, multiply its length, width and height.

Volume = length x width x height

To calculate the volume of this cuboid:

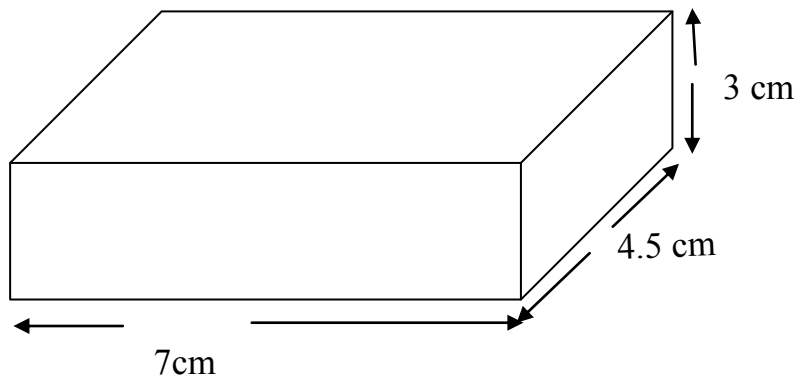

Volume = length x width x height

Volume = $7 \times 4.5 \times 3$

Answer: 94.5 cm^3

To calculate a missing dimension:

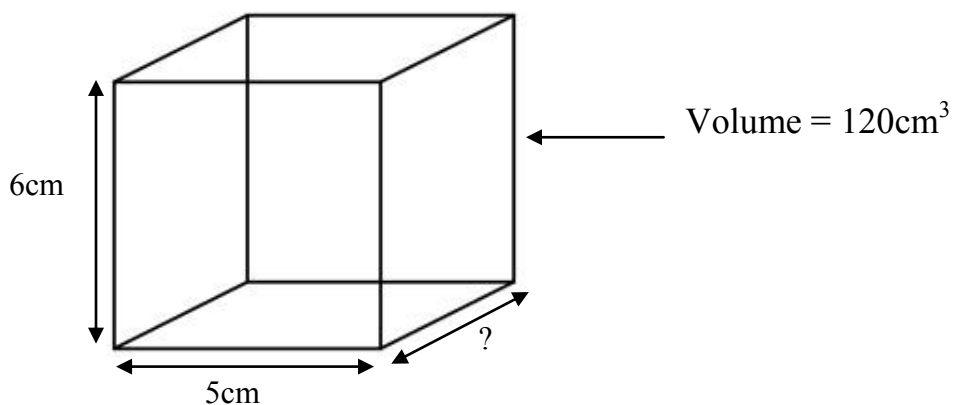

Volume = length x width x height

$120 = 6 \times 5 \times ?$

$120 = 30 \times ?$

$120 = 30 \times 4$

Answer: 4 cm

1. The **cuboid** below is 7 cm by 6.4 cm by 2 cm.

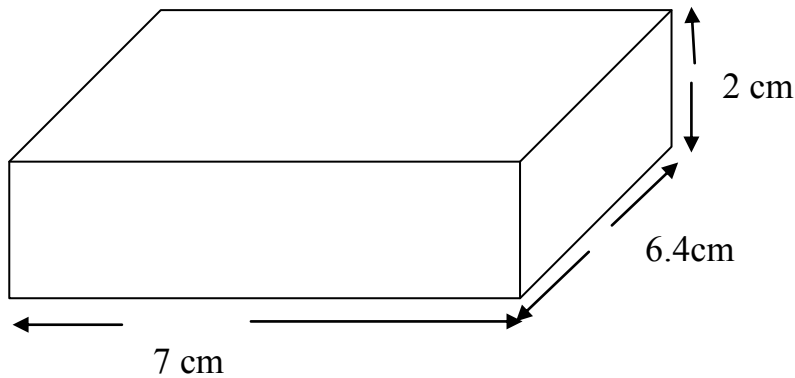

What is the **volume** of this cuboid? Write your answer in the space below.

_____ cm³

Look at the cuboid below.

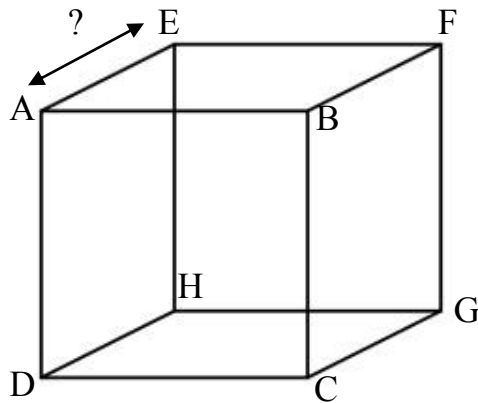

2. **ABCD** is a **square**. **Each side** of the square is 4cm. The **volume** of the cuboid is **80cm³**. What is the length of the line **AE**? Write your answer in the space below.

_____ cm

(2)

3. Look at the blocks below. One block is a cube and one block is a cuboid.

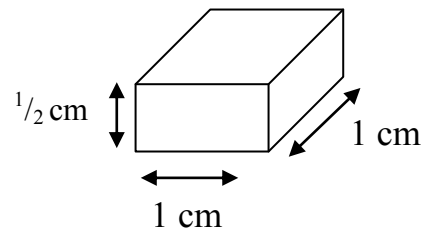
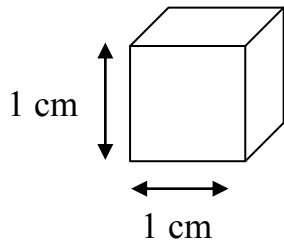

The blocks are used to build the structure below. The block has two layers of cubes and one layer of cuboids.

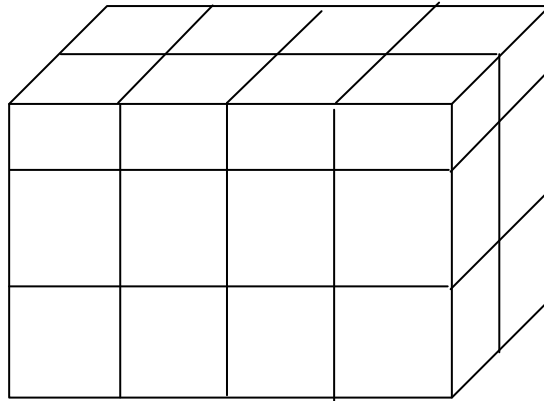

What is the **volume** of the block? Write your answer in the space below.

_____ cm^3



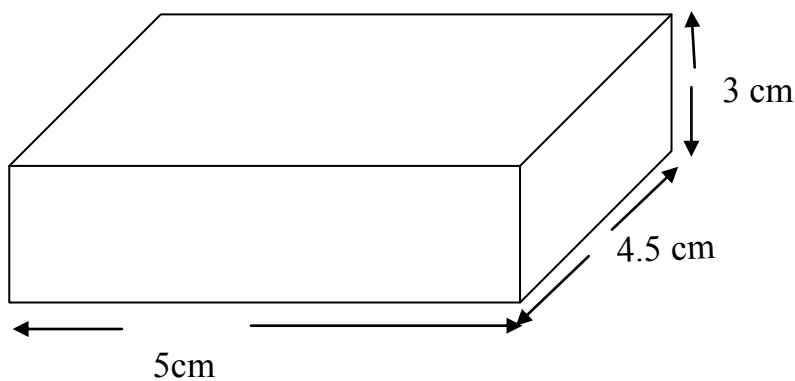

4. The **cuboid** below is 5 cm by 4.5 cm by 3 cm.

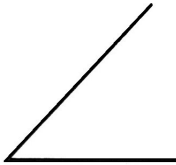

What is the **volume** of this cuboid? Write your answer in the space below.

_____ cm^3

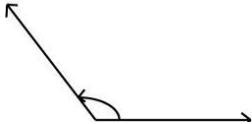
MAKE SURE YOU HAVE LEARNED THE INFORMATION ON THIS PAGE BEFORE TRYING THE QUESTIONS.

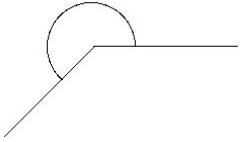
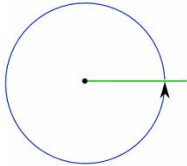
Angle	Name	Description
	Acute	Less than 90°
	Right-angle	90° exactly
	Obtuse	More than 90° less than 180°
	Straight-line	180° exactly
	Reflex	More than 180° less than 360°
	Full rotation	360° exactly

Each interval on the compass is 45°

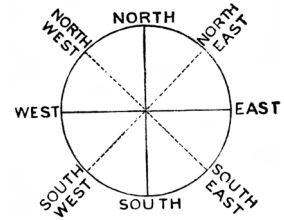

From	Clockwise to	Angle of Turn
North	North East	45°
North	East	90°
North	South East	135°
North	South	180°
North	South West	225°
North	West	270°
North	North West	315°
North	North	360°

Each interval on the clock is 30°

So...

The acute angle is 60°

The reflex angle is 300°

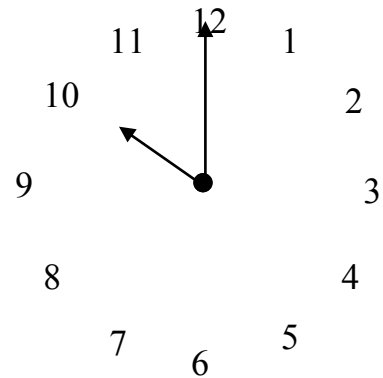

From	Clockwise to	Angle of Turn
12	1	30°
12	2	60°
12	3	90°
12	4	120°
12	5	150°
12	6	180°
12	7	210°
12	8	240°
12	9	270°
12	10	300°
12	11	330°
12	12	360°

1. A ballerina spins on the stage. She turns $2\frac{1}{4}$ times before stopping. How many degrees has she turned?

Write your answer in the space below.

_____°

2. Seana is facing **South**. She **turns through 45°** . In which direction is she now facing? There are **two possible correct answers**. Write your answers in the spaces below.

3. Look at the statements below. Tick each statement true or false.

	True	False
$\frac{1}{6}$ of a complete turn is an acute angle	<input type="checkbox"/>	<input type="checkbox"/>
$\frac{4}{6}$ of a complete turn is an obtuse angle	<input type="checkbox"/>	<input type="checkbox"/>
$\frac{5}{6}$ of a complete turn is less than 3 right angles	<input type="checkbox"/>	<input type="checkbox"/>

4. I face **East**. I turn **135° anti-clockwise**. In what direction do I now face? Tick the correct answer.

- South-East
- South-West
- North-East
- North-West
-

5. I am facing **South**. Through **how many degrees** must I turn **clockwise** to face **North East**? Write your answers in the space below.

_____°

(5)

Look at the stopwatch below.

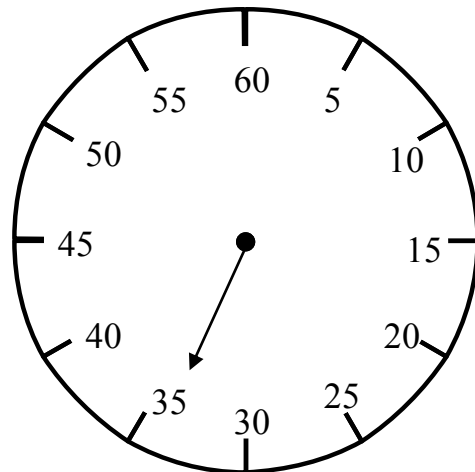

6. The hand on the stopwatch is pointing to **35**. The hand now moves **clockwise** through **210°** . What **number** will the hand be pointing to after turning **clockwise through 210°** ? Write your answer in the space below.

Look at the clock below.

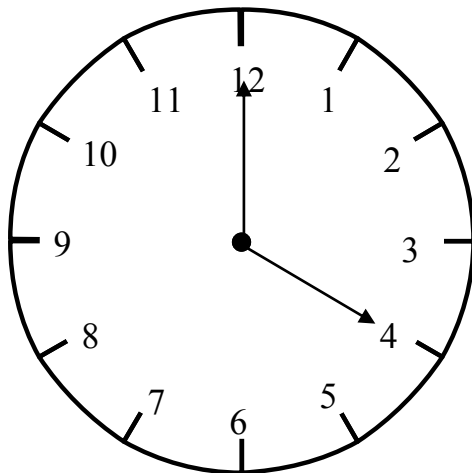

7. The hands of the clock show that the time is **4 o'clock**. What is the value of the **reflex angle between the hands** of the clock? Write your answer in the space below.

The passage you are about to read contains five errors. Read the passage and then answer the questions that follow it.

Non-Fiction Text

A sandwich that stays fresh for two years has been developed (line 1)
 for the US Army. Food scientists created the long-lasting (line 2)
 snack using engredients that can keep moisture trapped inside (line 3)
 them, like honey, salt and sugar. (line 4)
 (line 5)
 Thats important because the bacteria that decays food needs (line 6)
 water to grow, By keeping its moisture, the sandwich holds (line 7)
 off the bacteria and it stays fresh and tasty to eat! Inside the (line 8)
 sandwich wrapper there is also a tiny pack of iron shavings. It (line 9)
 zaps oxygen, which is another thing some bacteria need. (line 10)
 (line 11)
 The sandwich has been made to help feed soldiers while (line 12)
 their in the field. That's a big challenge because food has to (line 13)
 be light to carry, easy to eat, contain loads of energy and last a (line 14)
 long time. Would you like to eat a sandwich like this. (line 15)
 (line 16)

-
1. In one line of the passage a comma has been used incorrectly. A full stop rather than a comma should have been used. Tick the number of the line in which this error was made.

line 4

line 7

line 10

line 14

	(1)
--	-----

2. A question mark is needed instead of a full stop on one line of the passage. Tick the number of the line in which the question mark is needed.

line 4

line 10

line 13

line 15

3. There is a spelling error in one of the lines of the passage. Tick the number of the line containing the spelling error.

line 1

line 3

line 9

line 14

4. A word has been used incorrectly in the passage. Tick the number of the line containing the incorrect word.

line 7

line 9

line 13

line 14

5. There is an apostrophe missing from one of the words in the passage. Tick the number of the line containing the word with the missing apostrophe.

line 1

line 6

line 7

line 12

	(4)

33
Interior Angles

MAKE SURE YOU HAVE LEARNED THE INFORMATION ON THIS PAGE BEFORE TRYING THE QUESTIONS.

Remember: the interior angles of ANY TRIANGLE add to give 180°

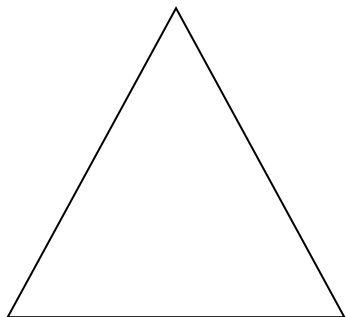

An Equilateral Triangle has:

- 3 sides the same length
- 3 angles the same
- Each angle is 60°

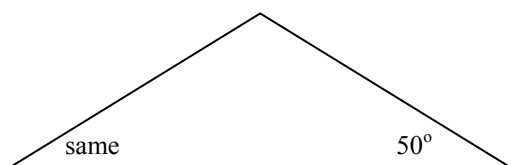

An Isosceles Triangle has:

- 2 sides the same length
- 2 angles the same

If you know one angle, you can work out the others.

If one angle is 50° so is the opposite angle.

$180 - 50 - 50 = 80^\circ$ so the last angle is 80°

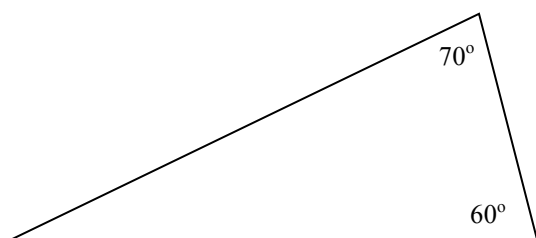

A Scalene Triangle has:

- no sides the same length
- no angles the same

If you know two angles, you can work out the other.

The angles we know are 70° and 60°

$180 - 60 - 70 = 50^\circ$ so the last angle is 50°

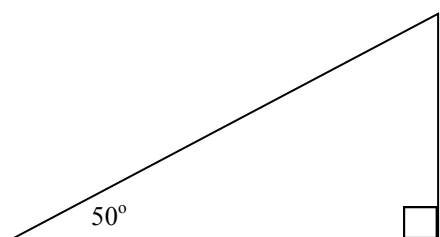

A Right-angled triangle has:

- One 90° angle.

If you know two angles, you can work out the other.

The angles we know are 90° and 50°

$180 - 90 - 50 = 40^\circ$ so the last angle is 40°

Remember: the interior angles of ANY QUADRILATERAL add to give 360°

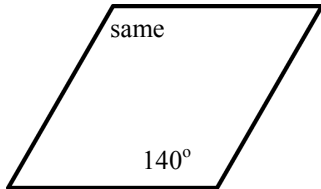

A rhombus has:

- All sides the same length
- Opposite angles are the same

If you know one angle, you can work out the others.
If one angle is 140° so is the opposite angle.
The angles at the same side add to give 180°
This means that the missing angles are each 40°

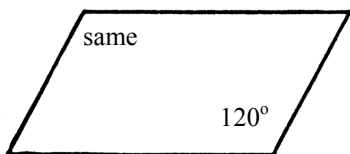

A parallelogram has:

- Opposite sides are the same length
- Opposite angles are the same

If you know one angle, you can work out the others.
If one angle is 120° so is the opposite angle.
The angles at the same side add to give 180°
This means that the missing angles are each 60°

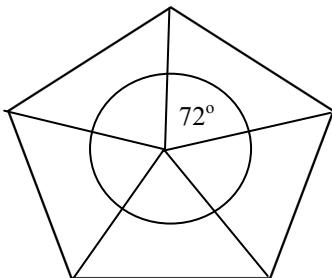

A regular pentagon has:

- 5 sides the same length
- 5 equal interior angles

There is a full rotation inside the pentagon.
The pentagon is divided into 5 equal parts.
 $360^\circ \div 5 = 72^\circ$

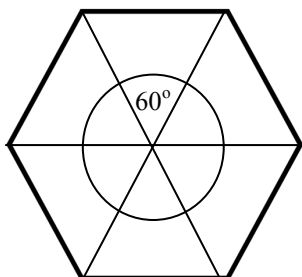

A regular hexagon has:

- 6 sides the same length
- 6 equal interior angles

There is a full rotation inside the hexagon.
The hexagon is divided into 6 equal parts.
 $360^\circ \div 6 = 60^\circ$

1. Look at the **hexagon** below. There are **6 equal angles** drawn at the centre of the hexagon. **Each angle is a°** .

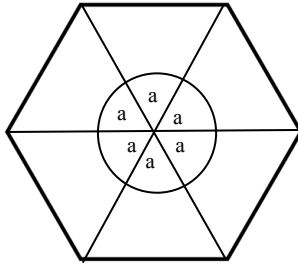

Write the **value of a** in the space below.

_____ $^\circ$

2. Look at the triangle and quadrilateral below.

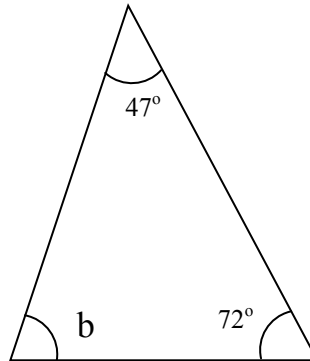
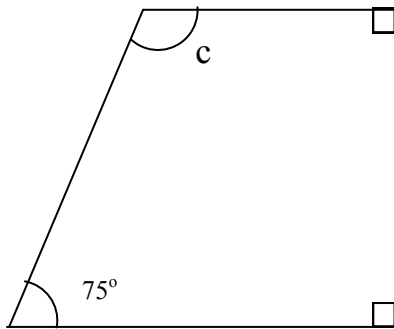

By **how many degrees** is angle **c** **greater** than angle **b** ?

Write your answer in the space below.

_____ $^\circ$

The **triangle** below is **isosceles**.

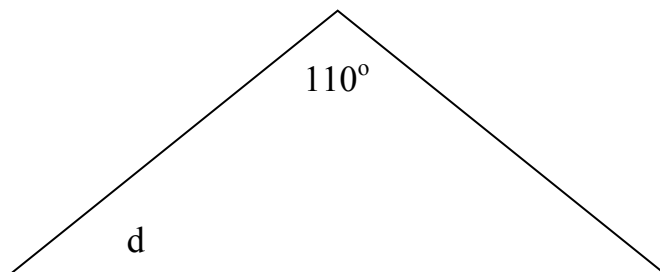

3. Calculate the value of the angle **d** . Write your answer in the space below.

_____ $^\circ$

4. Look at the **right-angled triangle** below.

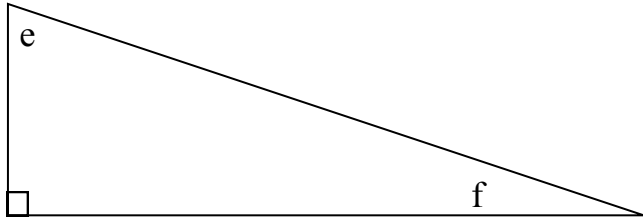

Angle **e** is **30° bigger than** angle **f**. What is the size of angle **f**?

Write your answer in the space below.

_____ °

5. Look at the **quadrilateral** below.

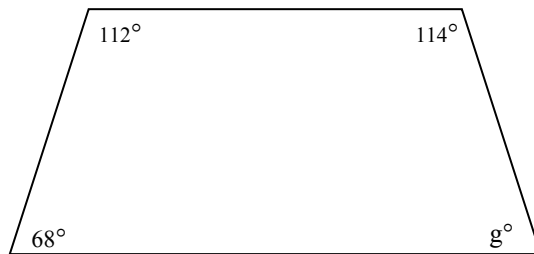

The angles of the quadrilateral are **112°**, **114°**, **68°** and **g**. Work out the size of the missing angle . Write your answer in the space below.

_____ °

6. Look at the 2 **triangles** below. The triangle **HIJ** is **isosceles**. The sides **HI** and **HJ** are the **same length**. The triangle **KLM** is **equilateral**.

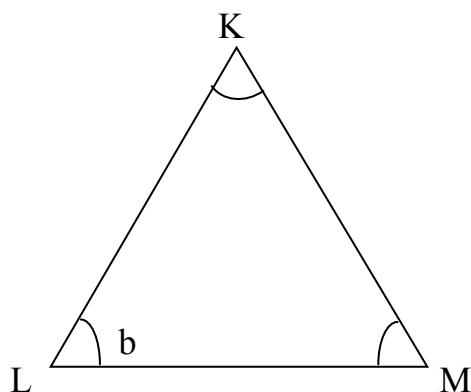
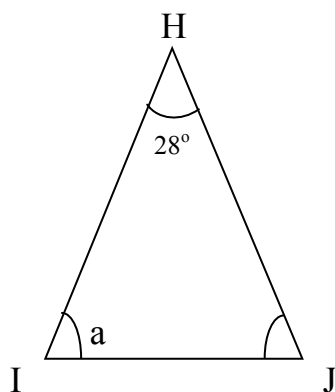

By **how many degrees** is angle **a greater than** angle **b**? Write your answer in the space below.

_____ °

MAKE SURE YOU HAVE LEARNED THE INFORMATION ON THIS PAGE BEFORE TRYING THE QUESTIONS.

Coordinates are a pair of numbers used to describe the position of a point.

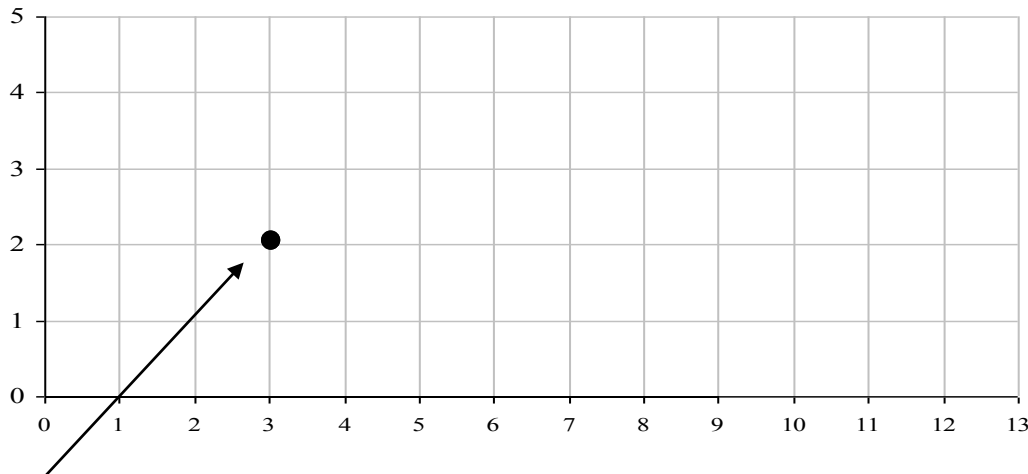

Look at (3,2)

(3, 2) means that the point is 3 across and 2 up.

THE FIRST NUMBER TELLS US HOW MANY SPACES WE GO ACROSS.

THE SECOND NUMBER TELLS US HOW MANY SPACES WE GO UP.

To remember this, we say:

You must crawl \longrightarrow before you can stand. \uparrow

You go in the door \longrightarrow before you go up the stairs. \uparrow

Look at the grid below.

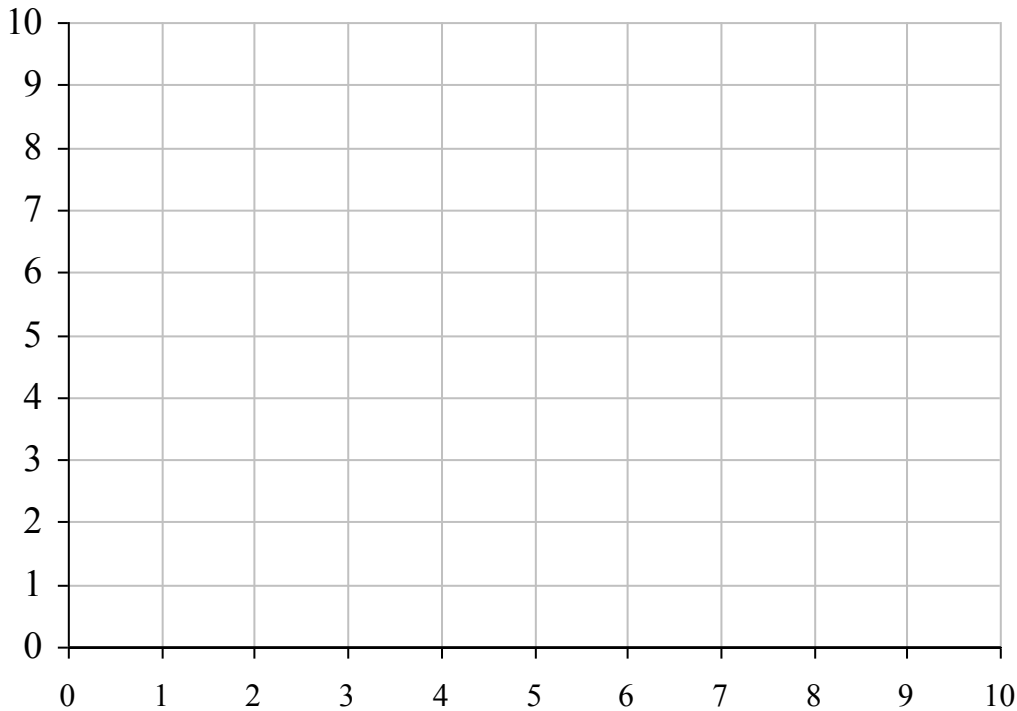

1.

- (a) Plot the points $(3, 2)$, $(7, 2)$ and $(3, 4)$ on the grid.
- (b) When a fourth point is added to the grid, the four points can be joined to form a rectangle. Write the coordinates of the fourth point in the space below.

2.

- (a) Plot the points $(2, 8)$, $(2, 10)$ and $(4, 10)$ on the grid.
- (b) When a fourth point is added to the grid, the four points can be joined to form a square. Write the coordinates of the fourth point in the space below.

(2)

3. **Three of the vertices of a parallelogram are shown by dots in the grid below.**

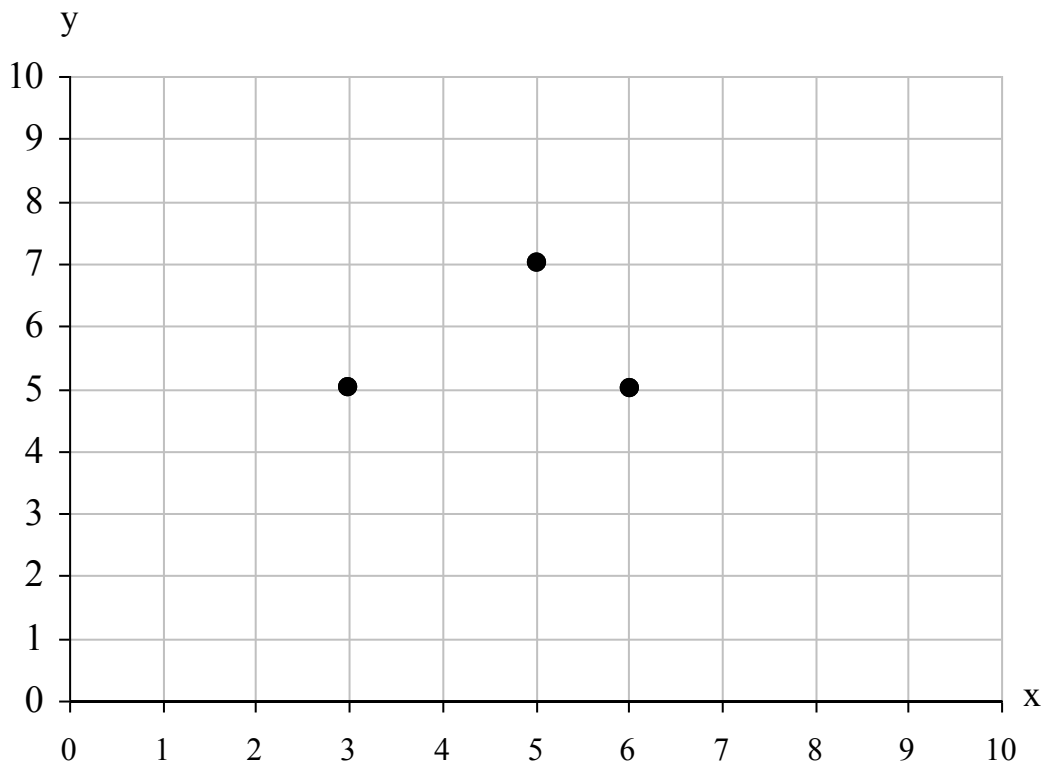

Two possible points for the fourth vertex can be drawn on the grid.
Write the **co-ordinates** of the **2 points** in the spaces below.

(,) (,)

4. In this question you may use the grid below to plot points. In each of the statements (a), (b) and (c) below you will be given the coordinates of four points. By plotting these four points and joining them **in order** you will be able to draw a **quadrilateral**.

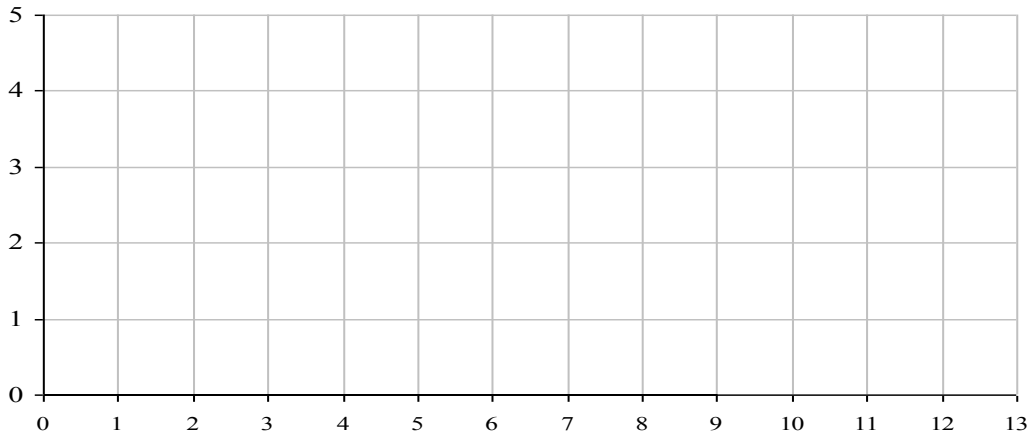

Here are the names of five quadrilaterals:

square rectangle parallelogram kite trapezium

Look at the statements below. Make statements (b) and (c) true by **choosing a name** from the five above. Write **the name** in the space provided. Statement (a) has been done for you.

(a) (2, 1) (4, 1) (2, 3) and (4, 3) join to make a **square**

(b) (8, 1) (12, 1) (9, 2) and (11, 2) join to make a _____

(c) (3, 5) (9, 5) (2, 3) and (8, 3) join to make a _____

Homonyms

MAKE SURE YOU HAVE LEARNED THE INFORMATION ON THIS PAGE BEFORE TRYING THE QUESTIONS.

If a word has been used incorrectly, then its homonym (same sound word) has been used in the passage instead.

Common homonyms to look out for are:

our	It is <u>our</u> classroom. (belonging to us)
are	We <u>are</u> going to school.
hour	There are sixty seconds in one <u>hour</u> .

there	The door is over <u>there</u> . (Talking about a place; notice how <u>here</u> is in <u>there</u>).
they're	<u>They're</u> (they are) my friends.
their	<u>Their</u> dog is very friendly. (belonging to them)

where	<u>Where</u> is the toilet? (Talking about a place; notice how <u>here</u> is in <u>where</u>).
were	We <u>were</u> going out to play. (past tense of are)
wear	I will <u>wear</u> my pyjamas to bed.

to	I am going <u>to</u> the shop.
too	Would you like to come <u>too</u> ?
two	The number after one is <u>two</u> .

its	The dog chewed <u>its</u> bone. (belonging to <u>it</u>).
it's	<u>It's</u> a fine day. (the contraction for <u>it is</u>).

1. The words **they're**, **their** and **there** sound the same but are used differently. Complete the sentences below correctly by writing the word **they're**, **their** and **there** in the space provided.

_____ looking for _____ dog. It might be over
_____.

2. The words **to**, **two** and **too** sound the same but are used differently. Complete each sentence by writing the word **to**, **two** or **too** in each of the blank spaces.

Fergus went to the shop _____ get _____ buns. His mum went to the
shop _____.

3. **It's** and **its** sound the same but have different meanings. Complete the sentences below correctly by circling either the word **it's** or **its** in each case.

It's / **its** important to look after your dog properly. Always make sure
it has water in **it's** / **its** bowl and brush **it's** / **its** coat so that it stays
neat and glossy.

(3)

4. The words **where**, **were** and **wear** sound the same but are used differently. Complete each sentence by writing the word **where**, **were** or **wear** in each of the blank spaces.

We wanted to buy something new to _____ to the party, but we -
 _____ not sure _____ the best shops _____ .

5. **Hour**, **our** and **are** sound the same but have different meanings. Complete the sentences below correctly by circling either the word **hour**, **our** or **are** in each case.

Hour / Our / Are lessons are so much fun! Tomorrow we **hour / our / are**
 going to spend an **hour / our / are** working on **hour / our / are** projects.

Addition Answers

$1 + 3 = 4$	$0 + 9 = 9$	$6 + 9 = 15$	$2 + 0 = 2$	$1 + 5 = 6$
$3 + 7 = 10$	$8 + 2 = 10$	$4 + 5 = 9$	$6 + 0 = 6$	$4 + 2 = 6$
$8 + 8 = 16$	$5 + 6 = 11$	$6 + 3 = 9$	$6 + 8 = 14$	$7 + 7 = 14$
$2 + 2 = 4$	$0 + 1 = 1$	$7 + 5 = 12$	$2 + 3 = 5$	$8 + 4 = 12$
$3 + 5 = 8$	$9 + 2 = 11$	$2 + 3 = 5$	$6 + 7 = 13$	$5 + 5 = 10$
$8 + 7 = 15$	$8 + 5 = 13$	$1 + 8 = 9$	$1 + 9 = 10$	$2 + 9 = 11$
$1 + 3 = 4$	$8 + 6 = 14$	$2 + 0 = 2$	$8 + 7 = 15$	$8 + 3 = 11$
$4 + 9 = 13$	$2 + 5 = 7$	$2 + 9 = 11$	$8 + 9 = 17$	$3 + 9 = 12$
$9 + 9 = 18$	$1 + 1 = 2$	$4 + 3 = 7$	$4 + 8 = 12$	$6 + 2 = 8$
$3 + 9 = 12$	$7 + 9 = 16$	$3 + 7 = 10$	$4 + 1 = 5$	$5 + 6 = 11$
$3 + 3 = 6$	$2 + 7 = 9$	$6 + 6 = 12$	$5 + 8 = 13$	$0 + 3 = 3$
$4 + 0 = 4$	$6 + 1 = 7$	$6 + 7 = 13$	$7 + 3 = 10$	$5 + 7 = 12$
$7 + 8 = 15$	$8 + 8 = 16$	$7 + 8 = 15$	$5 + 4 = 9$	$8 + 5 = 13$
$8 + 7 = 15$	$9 + 9 = 18$	$0 + 5 = 5$	$6 + 9 = 15$	$1 + 7 = 8$
$9 + 5 = 14$	$4 + 4 = 8$	$6 + 5 = 11$	$5 + 9 = 14$	$7 + 5 = 12$
$6 + 4 = 10$	$6 + 8 = 14$	$7 + 9 = 16$	$8 + 9 = 17$	$0 + 7 = 7$
$8 + 6 = 14$	$9 + 7 = 16$	$8 + 6 = 14$	$4 + 7 = 11$	$9 + 6 = 15$
$7 + 9 = 16$	$8 + 0 = 8$	$9 + 4 = 13$	$9 + 8 = 17$	$8 + 4 = 12$
$5 + 5 = 10$	$9 + 8 = 17$	$8 + 1 = 9$	$9 + 6 = 15$	$4 + 6 = 10$
$9 + 2 = 11$	$12 + 5 = 17$	$10 + 3 = 13$	$13 + 6 = 19$	$11 + 4 = 15$

Subtraction Answers

$0 - 0 = 0$	$6 - 1 = 5$	$7 - 3 = 4$	$1 - 1 = 0$	$8 - 3 = 5$
$9 - 5 = 4$	$2 - 1 = 1$	$9 - 4 = 5$	$9 - 9 = 0$	$4 - 0 = 4$
$2 - 0 = 2$	$10 - 6 = 4$	$5 - 4 = 1$	$5 - 0 = 5$	$6 - 5 = 1$
$6 - 2 = 4$	$3 - 0 = 3$	$3 - 1 = 2$	$7 - 6 = 1$	$9 - 7 = 2$
$10 - 5 = 5$	$2 - 1 = 1$	$3 - 3 = 0$	$7 - 2 = 5$	$6 - 3 = 3$
$6 - 5 = 1$	$8 - 4 = 4$	$5 - 1 = 4$	$4 - 1 = 3$	$12 - 9 = 3$
$12 - 7 = 5$	$7 - 4 = 3$	$5 - 2 = 3$	$4 - 4 = 0$	$11 - 8 = 3$
$8 - 7 = 1$	$5 - 2 = 3$	$11 - 6 = 5$	$8 - 5 = 3$	$3 - 2 = 1$
$14 - 9 = 5$	$9 - 8 = 1$	$12 - 9 = 3$	$6 - 6 = 0$	$8 - 6 = 2$
$5 - 5 = 0$	$9 - 6 = 3$	$4 - 3 = 1$	$10 - 7 = 3$	$13 - 9 = 4$
$12 - 8 = 4$	$2 - 2 = 0$	$11 - 7 = 4$	$13 - 8 = 5$	$7 - 3 = 4$
$11 - 2 = 9$	$17 - 9 = 8$	$10 - 1 = 9$	$8 - 8 = 0$	$4 - 2 = 2$
$7 - 5 = 2$	$5 - 3 = 2$	$9 - 9 = 0$	$9 - 3 = 6$	$9 - 0 = 9$
$8 - 2 = 6$	$6 - 4 = 2$	$14 - 5 = 9$	$6 - 0 = 6$	$10 - 6 = 4$
$12 - 6 = 6$	$13 - 4 = 9$	$6 - 4 = 2$	$17 - 9 = 8$	$15 - 4 = 11$
$16 - 5 = 11$	$7 - 1 = 6$	$13 - 7 = 6$	$11 - 5 = 6$	$7 - 7 = 0$
$16 - 8 = 8$	$17 - 3 = 14$	$13 - 3 = 10$	$17 - 8 = 9$	$14 - 5 = 9$
$18 - 9 = 9$	$13 - 7 = 6$	$10 - 4 = 6$	$12 - 3 = 9$	$18 - 9 = 9$
$15 - 6 = 9$	$19 - 7 = 12$	$13 - 2 = 11$	$16 - 7 = 9$	$16 - 3 = 13$
$14 - 3 = 11$	$12 - 4 = 8$	$17 - 5 = 12$	$14 - 6 = 8$	$18 - 7 = 11$

Multiplication Answers

$9 \times 1 = 9$	$8 \times 1 = 8$	$0 \times 0 = 0$	$4 \times 3 = 12$	$2 \times 1 = 2$
$7 \times 2 = 14$	$4 \times 2 = 8$	$9 \times 2 = 18$	$1 \times 1 = 1$	$3 \times 3 = 9$
$8 \times 4 = 32$	$0 \times 1 = 0$	$5 \times 1 = 5$	$3 \times 9 = 27$	$6 \times 2 = 12$
$0 \times 5 = 0$	$7 \times 1 = 7$	$3 \times 2 = 6$	$5 \times 5 = 25$	$1 \times 5 = 5$
$5 \times 3 = 15$	$2 \times 9 = 18$	$3 \times 4 = 12$	$0 \times 2 = 0$	$6 \times 4 = 24$
$1 \times 2 = 2$	$6 \times 3 = 18$	$0 \times 6 = 0$	$8 \times 3 = 24$	$1 \times 7 = 7$
$7 \times 3 = 21$	$4 \times 1 = 4$	$5 \times 4 = 20$	$2 \times 5 = 10$	$3 \times 1 = 3$
$6 \times 7 = 42$	$0 \times 3 = 0$	$1 \times 6 = 6$	$7 \times 4 = 28$	$0 \times 4 = 0$
$3 \times 5 = 15$	$4 \times 9 = 36$	$8 \times 2 = 16$	$2 \times 8 = 16$	$4 \times 4 = 16$
$7 \times 5 = 35$	$6 \times 1 = 6$	$2 \times 2 = 4$	$1 \times 3 = 3$	$2 \times 4 = 8$
$1 \times 8 = 8$	$2 \times 7 = 14$	$3 \times 6 = 18$	$6 \times 6 = 36$	$4 \times 6 = 24$
$8 \times 5 = 40$	$5 \times 6 = 30$	$7 \times 6 = 42$	$0 \times 7 = 0$	$5 \times 2 = 10$
$1 \times 4 = 4$	$2 \times 3 = 6$	$3 \times 8 = 24$	$8 \times 6 = 48$	$2 \times 6 = 12$
$4 \times 5 = 20$	$6 \times 5 = 30$	$7 \times 7 = 49$	$1 \times 9 = 9$	$4 \times 8 = 32$
$5 \times 8 = 40$	$0 \times 8 = 0$	$4 \times 7 = 28$	$9 \times 9 = 81$	$3 \times 7 = 21$
$7 \times 9 = 63$	$8 \times 7 = 56$	$6 \times 8 = 48$	$5 \times 7 = 35$	$9 \times 3 = 27$
$9 \times 5 = 45$	$9 \times 12 = 108$	$9 \times 4 = 36$	$0 \times 9 = 0$	$8 \times 9 = 72$
$9 \times 8 = 72$	$5 \times 9 = 45$	$7 \times 8 = 56$	$8 \times 12 = 96$	$9 \times 7 = 63$
$8 \times 8 = 64$	$7 \times 12 = 84$	$9 \times 6 = 54$	$6 \times 12 = 72$	$6 \times 9 = 54$
$11 \times 3 = 33$	$9 \times 6 = 54$	$4 \times 12 = 48$	$8 \times 7 = 56$	$5 \times 12 = 60$

Division Answers

$10 \div 5 = 2$	$4 \div 4 = 1$	$4 \div 1 = 4$	$3 \div 3 = 1$	$8 \div 2 = 4$
$24 \div 3 = 8$	$0 \div 0 = 0$	$18 \div 3 = 6$	$20 \div 5 = 4$	$0 \div 4 = 0$
$10 \div 2 = 5$	$6 \div 3 = 2$	$27 \div 3 = 9$	$2 \div 1 = 2$	$4 \div 2 = 2$
$8 \div 4 = 2$	$6 \div 2 = 3$	$0 \div 1 = 0$	$15 \div 5 = 3$	$36 \div 4 = 9$
$0 \div 7 = 0$	$5 \div 1 = 5$	$12 \div 4 = 3$	$9 \div 3 = 3$	$0 \div 6 = 0$
$40 \div 4 = 10$	$2 \div 2 = 1$	$1 \div 1 = 1$	$32 \div 4 = 8$	$30 \div 3 = 10$
$21 \div 3 = 7$	$0 \div 2 = 0$	$5 \div 5 = 1$	$12 \div 2 = 6$	$25 \div 5 = 5$
$12 \div 3 = 4$	$35 \div 5 = 7$	$7 \div 1 = 7$	$16 \div 4 = 4$	$28 \div 4 = 7$
$3 \div 1 = 3$	$12 \div 6 = 2$	$30 \div 5 = 6$	$18 \div 6 = 3$	$0 \div 3 = 0$
$35 \div 7 = 5$	$0 \div 5 = 0$	$15 \div 3 = 5$	$6 \div 6 = 1$	$40 \div 5 = 8$
$24 \div 4 = 6$	$50 \div 5 = 10$	$28 \div 7 = 4$	$0 \div 8 = 0$	$6 \div 1 = 6$
$24 \div 6 = 4$	$21 \div 7 = 3$	$60 \div 5 = 12$	$7 \div 7 = 1$	$42 \div 7 = 6$
$45 \div 5 = 9$	$44 \div 4 = 11$	$20 \div 4 = 5$	$8 \div 1 = 8$	$55 \div 5 = 11$
$54 \div 6 = 9$	$0 \div 9 = 0$	$24 \div 8 = 3$	$27 \div 9 = 3$	$8 \div 8 = 1$
$14 \div 7 = 2$	$16 \div 8 = 2$	$48 \div 6 = 8$	$49 \div 7 = 7$	$9 \div 1 = 9$
$80 \div 8 = 10$	$30 \div 6 = 5$	$64 \div 8 = 8$	$9 \div 9 = 1$	$40 \div 8 = 5$
$48 \div 8 = 6$	$18 \div 9 = 2$	$36 \div 9 = 4$	$36 \div 6 = 6$	$45 \div 9 = 5$
$42 \div 6 = 7$	$56 \div 7 = 8$	$32 \div 8 = 4$	$108 \div 9 = 12$	$60 \div 6 = 10$
$96 \div 8 = 12$	$54 \div 9 = 6$	$56 \div 8 = 7$	$63 \div 7 = 9$	$63 \div 9 = 7$
$72 \div 6 = 12$	$70 \div 7 = 10$	$72 \div 9 = 8$	$84 \div 7 = 12$	$72 \div 8 = 9$

Answers**2D Shape**

1. T F T T
2. F T T
3. T F F T
4. F F T

3D Shape

1. 5, 8, 5
2. 72 cm
3. 56 cm
4. 2, 1, 1
5. 5, 9, 6

Poetry Text

1. morning
2. robin, rod, rolling, rot, round
3. and daily fed with tenderest care
4. F T T
5. depressing

3D Shape: True or False

1. F T T F
2. T F F F
3. T F T T
4. T T F F
5. F F T T
6. T T F F

Nets

1. A D
2. C D
3. A C
- 4a. triangular prism
- 4b. cuboid

4c. triangular based pyramid

4d. cube

4e. square based pyramid

Apostrophes

1. I've, it'll, he'd
2. I am, I will / shall, you have
3. I'd, you're, it's
4. he is / has, you will / shall, you had / would
5. she's, she'll, it's
6. they will / shall, we are, they have
7. we'll, she's, we've
8. he is / has, they are, he will / shall

Volume

1. 89.6 cm^3
2. 5cm
3. 20 cm^3
4. 67.5 cm^3

Angles

1. 810°
2. SW and SE
3. T F F
4. NW
5. 225°
6. 10
7. 240°

Non-Fiction Text

1. line 7
2. line 15
3. line 3

4. line 13

5. Line 6

Interior Angles

1. 60°
2. 44°
3. 35°
4. 30°
5. 66°
6. 16°

Coordinates

1. (7, 4)
2. (4, 8)
3. (2, 7) (8, 7)
- 4b. trapezium
- 4c. parallelogram

Homonyms

1. they're, their, there
2. to, two, too
3. it's, its, its
4. wear, were, where, were
5. our, are, hour, our