

**ROLLS-ROYCE SILVER CLOUD**

**ROLLS-ROYCE SILVER CLOUD II**

**PHANTOM V**

# **Workshop Manual**

**BENTLEY S**

**BENTLEY S2**

**BENTLEY CONTINENTAL S**

**BENTLEY CONTINENTAL S2**

**SUPPLEMENT  
TSD 2003**

The name Bentley is a registered trademark of  
Bentley Motors Limited © 2005.

The name Rolls Royce is a registered trademark of  
Rolls Royce plc.

All material enclosed in this publication was accurate at original publication.  
Please refer to your authorised Bentley dealership for any update/ changes.  
Originally printed in 1963.

TSD Publication 2003  
Published by:-  
Bentley Motors Limited.

Re-printed by Elanders Hindson Limited, England.

## PREFACE

It is intended that this Supplement be read in conjunction with the Workshop Manual (T.S.D. Publication 729) for S1 and S2 cars. Where information in the Workshop Manual differs from that contained in the Supplement, it is that in the Supplement which applies to S3 cars.

It should be noted that the pages and titles to illustrations in this Supplement have a suffix (S) after the Page or figure number. The (S) has been added to avoid confusion with the page numbers in the Workshop Manual.

Page numbers and Figure numbers shown in parentheses in this Supplement, refer to the S1 and S2 Workshop Manual (T.S.D. Publication 729).

This Supplement to the Workshop Manual has been compiled in an endeavour to assist service personnel responsible for maintenance and overhaul, in properly maintaining the high standard of engineering achieved in the production of Rolls-Royce and Bentley motor cars.

Although all the information contained in this Supplement was correct when going to print, modifications which may subsequently develop will be kept up to date by means of Service Bulletins.

Information given in the latest Bulletin will supersede that given in the Section of this Supplement to which it refers, until such times as the Supplement is re-issued with the necessary amendments.

Personnel of Rolls-Royce Service Departments at Hythe Road, Willesden, London, N.W.10, and at Pym's Lane, Crewe, are always prepared to answer queries or give advice on individual servicing problems, but it will assist them if queries are accompanied by the chassis number of the car.

Information contained herein applies to the following cars

<b>Rolls-Royce</b>	<b>Bentley</b>
Silver Cloud III	S3
Silver Cloud III Long Wheelbase	S3 Long Wheelbase
Phantom V	Continental S3

The following publications are available for reference in conjunction with this Supplement

T.S.D. 471	Automatic gearbox service manual
T.S.D. 2034	Supplement to the automatic gearbox service manual
T.S.D. 753	Rolls-Royce Silver Cloud II and Bentley S2 engine manual
T.S.D. 2006	Supplement to the Rolls-Royce Silver Cloud II and Bentley S2 engine manual
T.S.D. 723	Air conditioning system — Underwing unit
T.S.D. 744	Air conditioning system — O.M.C. refrigeration unit

## CONTENTS

	<i>Chapter</i>
GENERAL INFORMATION .. .. .	A
AIR CONDITIONING .. .. .	C
LUBRICATION AND MAINTENANCE .. .. .	D
BRAKING SYSTEM .. .. .	G
SUSPENSION, SHOCK DAMPERS, PIVOT PINS AND STUB AXLES ..	H
FUEL SYSTEM AND CARBURETTORS .. .. .	K
ENGINE COOLING SYSTEM .. .. .	L
ELECTRICAL, IGNITION AND RADIO .. .. .	M
STEERING .. .. .	N
CHASSIS FRAME .. .. .	P
EXHAUST SYSTEM .. .. .	Q
WHEELS AND TYRES .. .. .	R
BODY .. .. .	S

# CHAPTER A

## GENERAL INFORMATION

<b>SECTION</b>		<b>PAGE</b>
<b>A 1</b>	<b>Specification — S3 Cars</b>	<b>A1(S)</b>

## CHAPTER A

# GENERAL INFORMATION

### SECTION A 1 SPECIFICATION — S3 CARS

<b>Engine</b>	Engine data appears in T.S.D. 2006.
<b>Fuel system</b>	
Carburettors	Two S.U. H.D.8. diaphragm type 2.00 in. choke bores. Automatic choke for cold starting.
Air cleaner	Either a Purolator paper type element or an oil wetted wire mesh filter element depending upon which country the engine will be operating in. For details see latest Service Bulletin Section D, dealing with this subject.
Fuel pumps	Twin S.U. electric.
Fuel tank capacity	18 galls. (Imp.) 21.6 galls. (U.S.) 81.8 litres.
Fuel strainers	Main fuel strainer mounted on the frame member in front of the fuel tank. Small gauze strainer at the carburetter inlets and in the fuel pumps.
Fuel gauge	Electric — registers when the ignition is switched on.
<b>Cooling system</b>	
Coolant capacity	21 pints (Imp.) 25.21 pints (U.S.) 11.93 litres.
Pump	Centrifugal
Fan	5-blade
Fan diameter	18 in.
Pump and fan drive	$\frac{1}{2}$ in. adjustable 'Vee' belts
Radiator matrix	Film type
Radiator shutters	Fixed
Coolant temperature control	82°C. – 86°C.
Temperature indicator	On instrument panel. Electric, registers when the ignition switch is on.
Coolant	An inhibited solution of ethylene glycol (B.S.S. 3150).
<b>Propeller shaft</b>	
	Divided type, having a ball and trunnion universal joint and two needle roller universal joints. The shaft is supported in the centre by a flexibly mounted ball race.

**Rear axle**

Type	Semi-floating
Final drive	Through a hypoid crown wheel and pinion.
Pinion teeth	
Standard S3 cars	13
Long Wheelbase S3 cars	13
Bentley Continental S3 cars	13
Phantom V cars	9
Crown wheel teeth	
Standard S3 cars	40
Long Wheelbase S3 cars	40
Bentley Continental S3 cars	40
Phantom V cars	35
Ratio	
Standard S3 cars	3.08 : 1
Long Wheelbase S3 cars	3.08 : 1
Bentley Continental S3 cars	3.08 : 1
Phantom V cars	3.89 : 1
Oil capacity of casing	
Standard S3 cars	1 $\frac{3}{8}$ pints
Long Wheelbase S3 cars	1 $\frac{3}{8}$ pints
Bentley Continental S3 cars	1 $\frac{3}{8}$ pints
Phantom V cars	1 $\frac{3}{4}$ pints

**Brakes**

Foot brake	Power assistance provided by a servo motor. Independent twin hydraulic system with additional mechanical linkage to rear shoes.
Hand brake	Mechanical to rear wheels. Warning lamp fitted, operates when hand brake is applied and ignition switched on.
Brake shoe linings	Ferodo DS2 or Mintex M 14
Friction lining area (4 brakes)	
S3 cars	240 sq.in. (1548 sq.cm.)
Early Bentley Continental S3 cars	304 sq.in. (1960 sq.cm.)
Late Bentley Continental S3 cars	240 sq.in. (1548 sq.cm.)
Phantom V cars	240 sq.in. (1548 sq.cm.)
Hand brake lever	Twist grip barrel type

**Servo motor**

General	The servo motor operates on the principle of the dry disc clutch. The lined friction plate is driven from the gearbox final shaft at approximately one-fifth of the propeller shaft speed.
Servo motor lining	Ferodo DM8
Cam angle	
S3 cars	37.5° — twin master cylinders
Early Bentley Continental S3 cars	47° — twin master cylinders
Late Bentley Continental S3 cars	37.5° — twin master cylinders
Phantom V cars	37.5° — twin master cylinders

**Front hubs**

General Two taper roller races

**Wheels and tyres**

Wheels Bolted-on pressed steel wheels with covering discs.

Rim wheels Well base rims, 6L × 15·00 in.

**Tyres**

Standard S3 cars 8·20 in. — 15·00 in.

Long Wheelbase S3 cars 8·20 in. — 15·00 in.

Bentley Continental S3 cars 8·00 in. — 15·00 in.

Phantom V cars 8·90 in. — 15·00 in.

**Steering**

Type Power assisted

Steering unit Cam and roller

Drive Right or left-hand

Steering wheel diameter 17 in.

**Suspension**

Front Independent coil spring suspension, hydraulic shock dampers and anti-roll stabiliser.

Rear (except Phantom V) Semi-elliptic leaf springs. Controllable hydraulic shock dampers. A special form of axle control rod is fitted which, together with the road springs, takes the torque and brake reaction.

Phantom V The Phantom V is as specified above with the exception of the rear axle control rod which is not fitted to the Phantom V chassis.

**Front shock dampers**

Make and type Rolls-Royce hydraulic double-acting.

**Rear shock dampers**

Make and type Rolls-Royce hydraulic double-acting.

General Controllable through a switch on the steering column.

**Chassis frame**

Type Box section throughout, with all welded joints.

**Jacking system**

Type Smith Bevelift jacks.

**Battery**

Make and type Either P & R Dagenite — 6 HZP 11/9 GZF  
or Exide — 6 XTHZ 11/L.

Voltage 12 v.

Capacity 67 ampere-hours

Earth Negative to chassis frame



**Ignition distributor**

Standard S3 cars and Continental S3 cars

Make and type

Lucas 20 D8. Eight lobe cam with double contact breakers.

Rotation

Anti-clockwise

Advance mechanism

Automatic centrifugal advance with built-in vacuum timing control.

Ignition timing

2° B.T.D.C.

Firing order

A1, B1, A4, B4, B2, A3, B3, A2.

( 1, 5, 4, 8, 6, 3, 7, 2.)

Contact gap

0.014 in. — 0.016 in.

Drive

Through camshaft skew gears

Phantom V

Make and type

Delco-Remy. Twin contact breakers with synchronised contact breaker arms.

Rotation

Anti-clockwise

Advance mechanism

Automatic (centrifugal governor)

Ignition timing

2° B.T.D.C.

Firing order

A1, B1, A4, B4, B2, A3, B3, A2.

( 1, 5, 4, 8, 6, 3, 7, 2.)

Contact gap

0.019 in. — 0.021 in.

Drive

Through camshaft skew gears

**Ignition coil**

Make

Lucas

**Sparking plugs**

Make and type

9 : 1 compression ratio

Champion RN.8

8 : 1 compression ratio

Champion RN.8, Champion RN.13P or Lodge CLNP.

Cars destined for Australia

Champion UN.12 Y

Gap

0.025 in.

**Generator**

Make

Lucas

Type

C 48

Maximum output

35 amperes, 13.5 v.

Drive

Twin 'Vee'-belts

Voltage regulator and cut-out

Lucas RB 310, current voltage type.

**Starter motor**

Make and type

Lucas M-45G. 12 v.

Rotation

Anti-clockwise (from front of the engine).

Flywheel to pinion ratio

18 : 1

**Horns**

Make and type

Lucas WT 618. Twin Wind-tone.

**Direction indicators**

Make and type

Lucas combined side lamps and flashing indicators, combined rear stop/tail and flashing indicators.

**Windscreen wipers**

Make and type

Lucas DR 3. Two-speed self-parking.

**Headlamps**

Make and type

Lucas 5¼ in. twin sealed beam headlamps mounted horizontally in each front wing.

General

A small red warning lamp, mounted in the speedometer is illuminated whenever the headlamps are switched to main beam. A switch for flashing the headlamp main beams is incorporated in the direction indicator switch.

**Fog lamps**

General

Twin fog lamps with single filament bulbs are fitted.

**Fuse box**

General

Large box contains eight circuit fuses. Each circuit fuse is one strand of No. 28 S.W.G. tinned copper wire. Spare fuse wire is provided on a special holder within large fuse box.

A small fuse box carries the horn fuse and headlamp flasher relay fuse. These are cartridge type fuses of 25 amp. rating.

**Heating, de-misting, de-icing and ventilation**

Standard S3 and Long Wheelbase cars

The 'Upper' heat exchanger under the right-hand front wing delivers fresh air which may be heated or at ambient temperature. Additional fresh air at ambient temperature can be obtained from a duct in the left-hand front wing.

The 'Lower' heat exchanger under the right-hand front wing delivers recirculated air to the car interior; this air may be heated or at ambient temperature.

The rear window is electrically heated.

**Windscreen washer**

Make

Lucas S2J 026

General

Electrically operated. Special liquid has a low surface tension and anti-freeze properties.

**Radio**

Make

Radiomobile

Type

620T Medium and long wave radio suitable for the whole of Europe with the exception of Spain, Portugal and Italy.

622T Medium wave radio suitable for the U.S.A., Canada and Japan.

230R Medium and short wave radio suitable for Africa, Asia, South America, West Indies, Italy, Spain and Portugal.

Make

Pye

Type

TCR 2000/E medium wave radio suitable for Australia and New Zealand.

**Body**

## General

Steel and light alloy stressed skin construction has been employed, the floor being an integral part of the body, to ensure optimum strength and rigidity consistent with lightness.

**Dimensions**

## Wheelbase

Standard S3 and Bentley Continental S3 cars	10 ft. 3 in. (312.4 cm.)
Long Wheelbase S3 cars	10 ft. 7 in. (322.6 cm.)
Phantom V cars	12 ft. 1 in. (368.3 cm.)

## Track, front

Standard S3, Bentley Continental S3 and Long Wheelbase S3 cars	4 ft. 10½ in. (148.6 cm.)
Phantom V cars	5 ft. 0⅞ in. (154.6 cm.)

## Track, rear

Standard S3, Bentley Continental S3 and Long Wheelbase S3 cars	5 ft. 0 in. (152.4 cm.)
Phantom V cars	5 ft. 4 in. (162.6 cm.)

## Overall length\* (including bumpers)

Standard S3 and Bentley Continental S3 cars	17 ft. 6½ in. (534.0 cm.)
Long Wheelbase S3 cars	17 ft. 10¼ in. (544.2 cm.)
Phantom V cars	19 ft. 8½ in. (620.2 cm.)

\*Cars destined for America will be approximately 1½ in. longer

## Overall width (over wings)

Standard S3 and Long Wheelbase S3 cars	6 ft. 2¾ in. (189.8 cm.)
Bentley Continental S3 cars	6 ft. 1 in. (185.4 cm.)
Phantom V cars	6 ft. 7 in. (200.6 cm.)

## Overall height (unladen)

Standard S3, Bentley Continental S3 and Long Wheelbase S3 cars	5 ft. 4 in. (162.6 cm.)
Phantom V cars	5 ft. 9 in. (175.3 cm.)

## Turning circle diameter

Standard S3 and Bentley Continental S3 cars	41 ft. 8 in. (12.70 m.)
Long Wheelbase S3 cars	43 ft. 0 in. (13.10 m.)
Phantom V cars	48 ft. 9 in. (14.86 m.)

## Weight, kerbside

Standard S3 cars	41.5 cwt. (2108 kgs.)
Bentley Continental S3 cars	38 cwt. (1930.5 kgs.)
Long Wheelbase S3 cars	43 cwt. (2184 kgs.)
Phantom V cars	50 cwt. (2540 kgs.)

## SECTION A2 — CHASSIS TORQUE TIGHTENING CHART

### TORQUE FIGURES — CADMIUM PLATED STANDARD PARTS

Size	Full Nut Torque		Half Nut Torque	
2 B.A.	48 lb. in.	to 60 lb. in.	30 lb. in.	to 36 lb. in.
$\frac{1}{8}$ in. UNF $\frac{7}{16}$ in. A.F.	8 lb. ft. (0.97 kg.m.)	to 10 lb. ft. (1.39 kg.m.)	5 lb. ft. (0.69 kg.m.)	to 10 lb. ft. (1.39 kg.m.)
$\frac{1}{16}$ in. UNF $\frac{1}{2}$ in. A.F.	16 lb. ft. (2.21 kg.m.)	to 18 lb. ft. (2.49 kg.m.)	13 lb. ft. (1.80 kg.m.)	to 15 lb. ft. (2.07 kg.m.)
$\frac{3}{16}$ in. UNF $\frac{9}{16}$ in. A.F.	29 lb. ft. (4.01 kg.m.)	to 32 lb. ft. (4.42 kg.m.)	22 lb. ft. (3.04 kg.m.)	to 25 lb. ft. (3.46 kg.m.)
$\frac{7}{16}$ in. UNF $\frac{5}{8}$ in. A.F.	42 lb. ft. (5.80 kg.m.)	to 45 lb. ft. (6.22 kg.m.)	33 lb. ft. (4.56 kg.m.)	to 36 lb. ft. (4.98 kg.m.)
$\frac{1}{2}$ in. UNF $\frac{3}{4}$ in. A.F.	60 lb. ft. (8.30 kg.m.)	to 65 lb. ft. (9.00 kg.m.)	48 lb. ft. (6.63 kg.m.)	to 52 lb. ft. (7.19 kg.m.)
$\frac{5}{8}$ in. UNF —	85 lb. ft. (11.75 kg.m.)	to 90 lb. ft. (12.44 kg.m.)	73 lb. ft. (10.10 kg.m.)	to 78 lb. ft. (10.80 kg.m.)

#### Setscrews

All setscrews are to be torque tightened to the appropriate figures quoted in the above table for full nuts, unless otherwise specified.

#### Important

In order to ensure correct torque tightness figures are obtained for plated parts, all burrs and foreign matter e.g. grit, grease and paint must be removed from the abutment faces of the nuts, setscrews, washers and components.

#### Non-Plated Parts

The following non-plated parts are to be torque tightened to the appropriate figures quoted in the above table for cadmium plated parts.

Rear spring 'U' bolts.

Exhaust downtake pipe.

The torque loadings for non-plated nuts and bolts apply when engine oil is smeared on the threads and the bolt or nut faces.

**For SPECIAL TORQUE TIGHTNESS FIGURES, see overleaf**

## SPECIAL TORQUE TIGHTNESS FIGURES

	<b>Torque</b>
<b>Bumpers — Front and Rear</b>	
$\frac{3}{8}$ in. dia. UNF nut — Output flange .. .. .	10 lb. ft. (1.39 kg.m.) to 12 lb. ft. (1.66 kg.m.)
<b>Dampers — Front</b>	
$\frac{7}{16}$ in. dia. UNF nut — Piston actuating lever .. .. .	60 lb. ft. (8.30 kg.m.) to 70 lb. ft. (9.68 kg.m.)
$\frac{7}{16}$ in. dia. UNF filler plug .. .. .	12 lb. ft. (1.66 kg.m.) to 15 lb. ft. (2.07 kg.m.)
$\frac{5}{16}$ in. dia. UNF solenoid control plug .. .. .	10 lb. ft. (1.38 kg.m.) to 12 lb. ft. (1.66 kg.m.)
$\frac{7}{8}$ in. dia. UNF rear plug .. .. .	30 lb. ft. (4.15 kg.m.) to 45 lb. ft. (6.22 kg.m.)
<b>Dampers — Rear</b>	
$\frac{7}{16}$ in. dia. UNF nut — Piston actuating lever .. .. .	60 lb. ft. (8.30 kg.m.) to 70 lb. ft. (9.68 kg.m.)
$\frac{7}{16}$ in. dia. UNF filler plug .. .. .	12 lb. ft. (1.66 kg.m.) to 15 lb. ft. (2.07 kg.m.)
$\frac{5}{16}$ in. dia. UNF solenoid control plug .. .. .	10 lb. ft. (1.38 kg.m.) to 12 lb. ft. (1.66 kg.m.)
$\frac{7}{8}$ in. dia. UNF rear plug .. .. .	30 lb. ft. (4.15 kg.m.) to 45 lb. ft. (6.22 kg.m.)
$\frac{1}{2}$ in. dia. UNF nut — Damper links .. .. .	45 lb. ft. (6.22 kg.m.) to 60 lb. ft. (8.30 kg.m.)
<b>Drag Link and Track Rods</b>	
$\frac{3}{8}$ in. dia. nut securing ball pins .. .. .	35 lb. ft. (4.84 kg.m.) to 40 lb. ft. (5.53 kg.m.)
$1\frac{1}{4}$ in. dia. UNF ball pin socket plug .. .. .	45 lb. ft. (6.22 kg.m.) to 50 lb. ft. (6.91 kg.m.)
<b>Frame and Fittings</b>	
$\frac{7}{8}$ in. dia. nut — Rear spring front anchorage .. .. .	150 lb. ft. (20.73 kg.m.) to 180 lb. ft. (24.88 kg.m.)
<b>Front Suspension</b>	
<b>B</b> $\frac{3}{4}$ in. dia. UNF fulcrum pin — Upper .. .. .	150 lb. ft. (20.73 kg.m.)
<b>B</b> $1\frac{1}{4}$ in. dia. UNF threaded bushes — Lower triangle levers .. .. .	250 lb. ft. (34.57 kg.m.)

**Rolls-Royce Silver Cloud III, and Phantom V**  
**Bentley S3 and Bentley Continental S3**

**Workshop Manual**  
**Supplement**

**Fuel Pumps**

$\frac{3}{8}$ in. dia. cone adaptors (light alloy) .. .. .	17 lb. ft. (2.35 kg.m.)
	to 20 lb. ft. (2.77 kg.m.)

**Fuel Tank**

$\frac{3}{8}$ in. dia. adaptor .. .. .	17 lb. ft. (2.35 kg.m.)
	to 20 lb. ft. (2.77 kg.m.)
1 in. dia. drain plug .. .. .	35 lb. ft. (4.84 kg.m.)
	to 40 lb. ft. (5.53 kg.m.)

**Generator**

C47 — Nut — Retaining fan and pulley .. .. .	50 lb. ft. (6.91 kg.m.)
C48 — Nut — Retaining fan and pulley .. .. .	40 lb. ft. (5.53 kg.m.)

**Hubs — Front**

$\frac{1}{4}$ in. dia. UNF screw — Drum .. .. .	30 lb. in.
	to 35 lb. in.
$\frac{1}{2}$ in. dia. UNF wheel nuts .. .. .	45 lb. ft. (6.22 kg.m.)
	to 50 lb. ft. (6.91 kg.m.)

**Hubs — Rear**

$\frac{1}{2}$ in. dia. UNF wheel nuts .. .. .	45 lb. ft. (6.22 kg.m.)
	to 50 lb. ft. (6.91 kg.m.)

**Lamps and Body Electrical Fittings**

$\frac{3}{8}$ in. dia. nut — Fog lamps .. .. .	27 lb. ft. (3.73 kg.m.)
	to 30 lb. ft. (4.15 kg.m.)

**Pipes and Fittings**

$\frac{1}{8}$ in. British standard pipe fitting — fuel filter drain plug .. .. .	7 lb. ft. (0.97 kg.m.)
	to 9 lb. ft. (1.24 kg.m.)
Brake hose lock-nuts .. .. .	10 lb. ft. (1.39 kg.m.)
	to 12 lb. ft. (1.66 kg.m.)
All brake pipe nuts are to be torque tightened .. .. .	10 lb. ft. (1.39 kg.m.)
	to 12 lb. ft. (1.66 kg.m.)
All Bijur pipe nuts are to be torque tightened .. .. .	5 lb. ft. (0.69 kg.m.)
	to 8 lb. ft. (1.11 kg.m.)
$\frac{3}{8}$ in. dia. cone adaptors — Filter .. .. .	17 lb. ft. (2.35 kg.m.)
	to 20 lb. ft. (2.77 kg.m.)
$\frac{3}{8}$ in. dia. sleeve — Fuel pipes .. .. .	12 lb. ft. (1.66 kg.m.)
	to 14 lb. ft. (1.94 kg.m.)

**Propeller Shaft**

1 in. dia. UNF nut propeller shaft flange .. .. .	150 lb. ft. (20.73 kg.m.)
	to 180 lb. ft. (24.88 kg.m.)
A $\frac{7}{16}$ in. dia. UNF nut — Detroit joint to flange .. .. .	45 lb. ft. (6.22 kg.m.)
	to 50 lb. ft. (6.91 kg.m.)
B $\frac{9}{16}$ in. dia. UNF nut — Detroit joint to flange .. .. .	70 lb. ft. (9.68 kg.m.)
	to 75 lb. ft. (10.37 kg.m.)

**Rear Axle**

1 in. dia. UNF ventilator plug	.. .. .	30 lb. ft. (4.15 kg.m.)
1 in. dia. UNF filler and drain plug	.. .. .	to 35 lb. ft. (4.84 kg.m.)
1 in. dia. UNF nut — Pinion flange	.. .. .	to 50 lb. ft. (6.91 kg.m.)
1 1/8 in. dia. UNF nut — Pinion bearing	.. .. .	195 lb. ft. (27.00 kg.m.)
1/16 in. dia. UNF setscrews — Axle tube to end plate	.. .. .	to 215 lb. ft. (29.43 kg.m.)
3/8 in. dia. UNF setscrews — Axle tube to wheel bearing housing	.. .. .	150 lb. ft. (20.73 kg.m.)
1/16 in. dia. UNF nuts — Securing end plate to centre casing	.. .. .	to 180 lb. ft. (24.88 kg.m.)
3/8 in. dia. UNF nuts — Crown wheel to differential casing	.. .. .	22 lb. ft. (3.04 kg.m.)
		to 24 lb. ft. (3.32 kg.m.)
		38 lb. ft. (5.26 kg.m.)
		to 40 lb. ft. (5.53 kg.m.)
		22 lb. ft. (3.04 kg.m.)
		to 24 lb. ft. (3.32 kg.m.)
		45 lb. ft. (6.22 kg.m.)
		to 50 lb. ft. (6.91 kg.m.)

**Side Steering Lever**

3/8 in. dia. UNF setscrew (non waisted and no identification mark)	As torque figure for standard parts
7/16 in. dia. UNF setscrew (non waisted and no identification mark)	As torque figure for standard parts
3/8 in. dia. UNF setscrew (waisted and vee cuts on corners of hexagon for identification)	37 lb. ft. (5.11 kg.m.)
	to 42 lb. ft. (5.81 kg.m.)
7/16 in. dia. UNF setscrew (waisted and vee cuts on corners of hexagon for identification)	54 lb. ft. (7.47 kg.m.)
	to 57 lb. ft. (7.88 kg.m.)

**Wiring and Fittings**

2 B.A. nut — Starter motor solenoid, tighten lightly (because of pulling on to rubber), fit and tighten lock-nut	.. .. .	24 lb. in.
		to 30 lb. in.

**Yoke and Cross Steering Pivots**

A 3/4 in. UNF adaptor with 1/8 in. reducing adaptor for yoke lubrication	.. .. .	35 lb. ft. (4.84 kg.m.)
		to 40 lb. ft. (5.53 kg.m.)

**Miscellaneous**

All cheesehead screws including those of worm-drive clips are to be torque tightened to 20 lb. in.

**ITEMS WHICH ARE NOT TORQUE TIGHTENED**

1. Nuts which are locked by riveting
2. 3 1/8 in. dia. UNF nut — Oil seal housing retaining — Rear axle
3. Woodscrews
4. Bearing end float adjustment nuts — Front stub axles
5. The 1/4 in. dia. screws in door striker plates
6. All threads less than 2 B.A.
7. Front door private locks 3/8 in. dia. nuts

A S1 Series

B S2 Series onwards

Torque tightening figures for the threads of the engine and gearbox interior components are not included

# CHAPTER C

## AIR CONDITIONING

SECTION		PAGE
C2	Underwing Air Conditioning Unit . . . . .	C1 (S)



## CHAPTER C

## AIR CONDITIONING

## SECTION C2

**The underwing air conditioning unit**  
(Page C 7 in Workshop Manual)

**Note** The air conditioning system fitted to Continental S3 and Phantom V cars is the same as that described in the Workshop Manual.

**For S3 cars read as follows**

**On standard Silver Cloud III and Bentley S3 cars** the de-misting, heating and ventilation system is built into a single unit mounted under the right-hand front wing. This unit can supply fresh and recirculated air at the desired temperature to all regions of the car, through concealed ducting.

The air supply of a non-refrigerated car can be considered as two independent systems; one system heating fresh air drawn from outside the car and the second system heating air recirculated within the car interior. As the upper section of the heating unit is

devoted to one system and the lower section to the other, the systems are identified as 'Upper' and 'Lower' as shown in Figure C1(S) of this Supplement.

**'Upper' or fresh air system**

In the 'Upper' system, fresh air is admitted through an intake in the right-hand front wing of the car and is filtered through a fine gauze. It is then boosted, if so required, by a blower motor through the heat exchange matrix in the main air conditioning unit. The air then passes along a cross-duct below the facia and is admitted to the front compartment through the windscreen de-misting slots and the adjustable outlets in the facia capping rail.

The flap valves controlling the air flow through the heat exchanger matrix are controlled by electric actuators, as is the tap controlling the flow of hot engine coolant to the 'Upper' heater matrix.

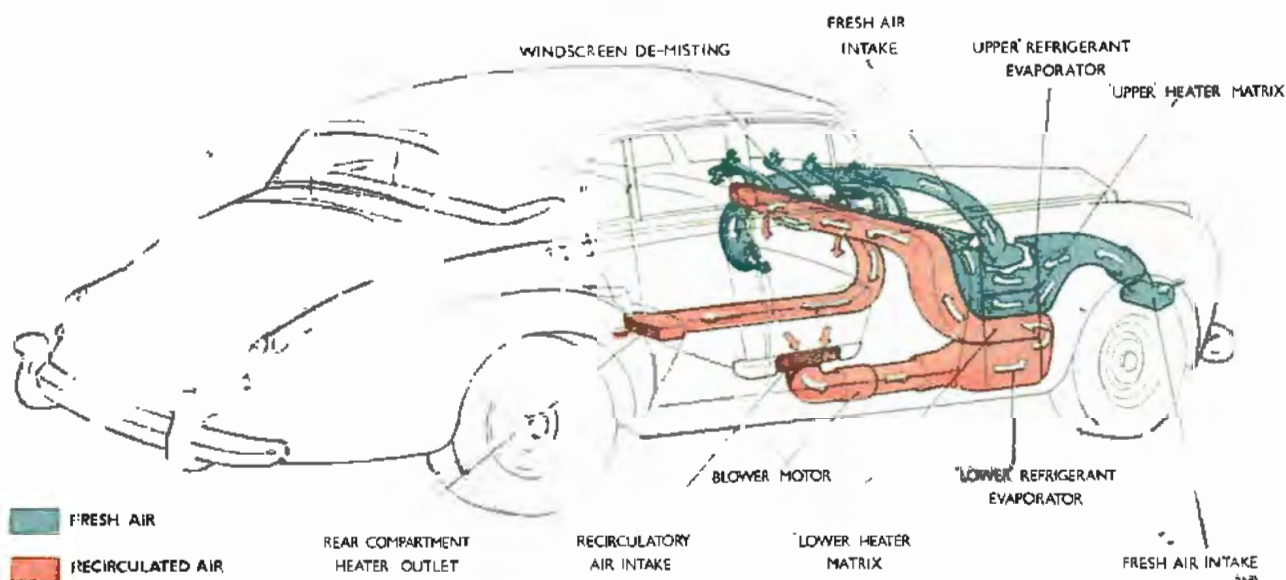

Fig. C1(S) Air circulation diagram

**'Upper' airstream switch**  
(Page C 9 in Workshop Manual)

**S3 cars only**

This switch controls the heater and evaporator flap actuators, blower motor, water tap actuator and refrigeration compressor clutch (if fitted).

The switch utilises seven angular positions which are: vertical 'off' position, four positions clockwise and two positions anti-clockwise. If refrigeration is fitted a third anti-clockwise position is incorporated.

With the switch knob 'in' air enters the saloon only through ram effect induced by the forward motion of the car. When the switch is withdrawn to its first or second position, air flow is increased by a blower motor operating at half and full speed respectively. This is achieved by the provision of a contact sleeve

'Upper' switch terminal identification is as follows

TERMINAL NUMBER	COLOUR OF WIRE	FUNCTION
1	Brown and black	Water tap leak
2	Red and white	Evaporator flap closed
3	Purple and black	Supply
4	Green and purple	Water tap fully open
6	Purple	Heater fully open
7	Brown and red	Water tap closed
8	Red and Green	Heater flap closed
10	Red	Evaporator flap fully open
11	Brown	Blower motor medium speed
12	Yellow	Blower motor full speed
13	Blue and black	Evaporator flap two-thirds open
14	Purple and green	Evaporator flap one-third open

SWITCH POSITION	CORRESPONDING POSITION OF FLAPS AND ACTUATORS	EFFECT PRODUCED
1st right	Water tap leak Hot flap full open Cold flap full open	Tepid air
2nd right	Water tap leak Hot flap full open Cold flap two-thirds open	Warm air
3rd right	Water tap full open Hot flap full open Cold flap one-third open	Hot air
4th right	Water tap full open Hot flap full open Cold flap shut	Very hot air
1st left	Water tap shut Hot flap full open Cold flap shut	Fresh air low volume
2nd left	Water tap shut Hot flap full open Cold flap full open	Fresh air full volume

at the end of the switch spindle; this sleeve connects with two fixed contacts, one of which is placed slightly forward of the other. When the knob is withdrawn to the first position, the most forward of the two contacts connects with the contact sleeve and introduces a resistance into the blower motor circuit, causing the blower motor to operate at half speed. When the knob is withdrawn to the second position the second fixed contact connects with the contact sleeve and by-passes the resistance in the blower motor circuit.

The main switch mechanism consists basically of five sets of moving contacts which rotate when the control knob is turned. Lobes on the contacts 'make' and 'break' with fixed contacts spaced around the arc of travel. The effect produced by each position of the switch is described in Figure C2(S) of this Supplement.

Further ventilation may be obtained for the front compartment through an auxiliary duct which directs fresh air, at ambient temperature, from an intake in the left-hand front wing to a grille in the left-hand scuttle wall.

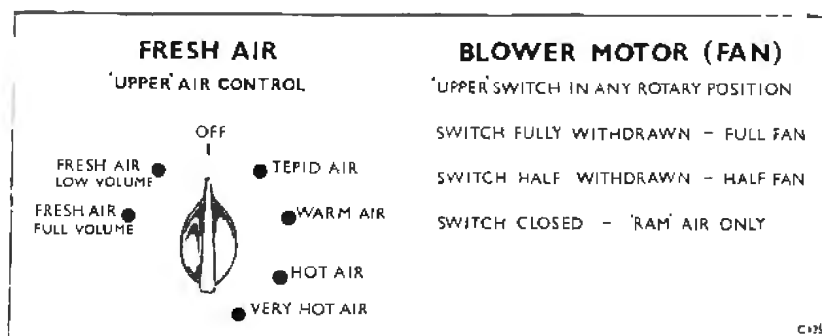

Fig. C2(S) Switch positions heating unit 'Upper' system

Air flow through this duct is controlled by a butterfly valve which is cable operated by an independent control beneath the fascia adjacent to the steering column. On long wheelbase cars with a division this control is marked 'Fresh Air' and is positioned adjacent to the 'Upper' switch.

### 'Lower' or recirculatory system

#### S3 cars only

The air intake grille for this system is positioned at the right-hand side of the driver's seat, projecting into both the front and rear compartments. Air is drawn through this grille by the action of a blower motor and passed through the lower heat exchanger matrix.

The air then enters the interior of the car via the cross-duct beneath the fascia and a centre duct which passes beneath the front seats to the rear compartment.

### 'Lower' airstream switch

(Page C 10 in Workshop Manual)

For S3 cars the 'Note' is not applicable.

The effect produced by each position of the switch is described in Figure C3 (S) of this Supplement.

SWITCH POSITION	CORRESPONDING OPERATIONS OF WATER TAP AND BLOWER MOTOR	EFFECT PRODUCED
1st right	Motor half speed Water tap leak	Warm air Half fan
2nd right	Motor half speed Water tap full open	Hot air Half fan
3rd right	Motor full speed Water tap full open	Hot air Full fan
1st left	Motor half speed Water tap shut	Unheated air Half fan
2nd left	Motor full speed Water tap shut	Unheated air Full fan

'Lower' switch terminal identification is as follows

TERMINAL NUMBER	COLOUR OF WIRE	FUNCTION
1	Yellow	Blower motor full speed
2	Blue	Blower motor medium speed
3	Purple and black	Supply
4	Green and white	Water tap leak
7	Red and black	Water tap closed
8	Purple and black	Supply
11	Green and black	Water tap open

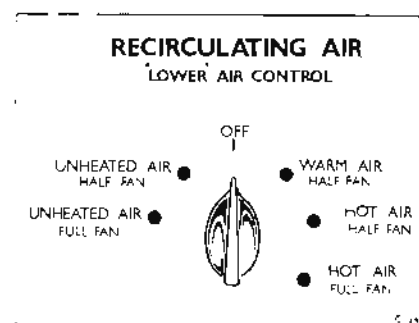

Fig. C3 (S) Switch positions heating unit 'Lower' system

### Right-hand front wing — To remove (Page C 11 in Workshop Manual)

For S3 cars the second to sixth paragraphs are not applicable. The seventh and eighth paragraphs to read

Unscrew the four bolts which secure the top of the radiator to the matrix and the bonnet centre stay, also the bolts securing the lower end of the shell to the undertray and front apron.

Remove the bolts securing the front apron to the side fairing, also the four nuts, bolts and washers securing the right-hand side fairing to the wing.

For S3 cars the following three paragraphs should be read in place of the eleventh

Remove the interior trim from the right-hand scuttle wall; this exposes the bolts which secure the rear vertical edge of the wing.

Remove the four bolts from the right-hand scuttle wall. Open the door approximately half way and remove the bolt which secures the rear lower edge of the wing to the sill.

Open the door fully and remove the bolt which secures the rear top edge of the wing to the scuttle wall. Remove also the two self-tapping screws and one bolt which secure the stainless steel strip to the lower edge of the wing.

For S3 cars the paragraph headed 'Note' is not applicable.

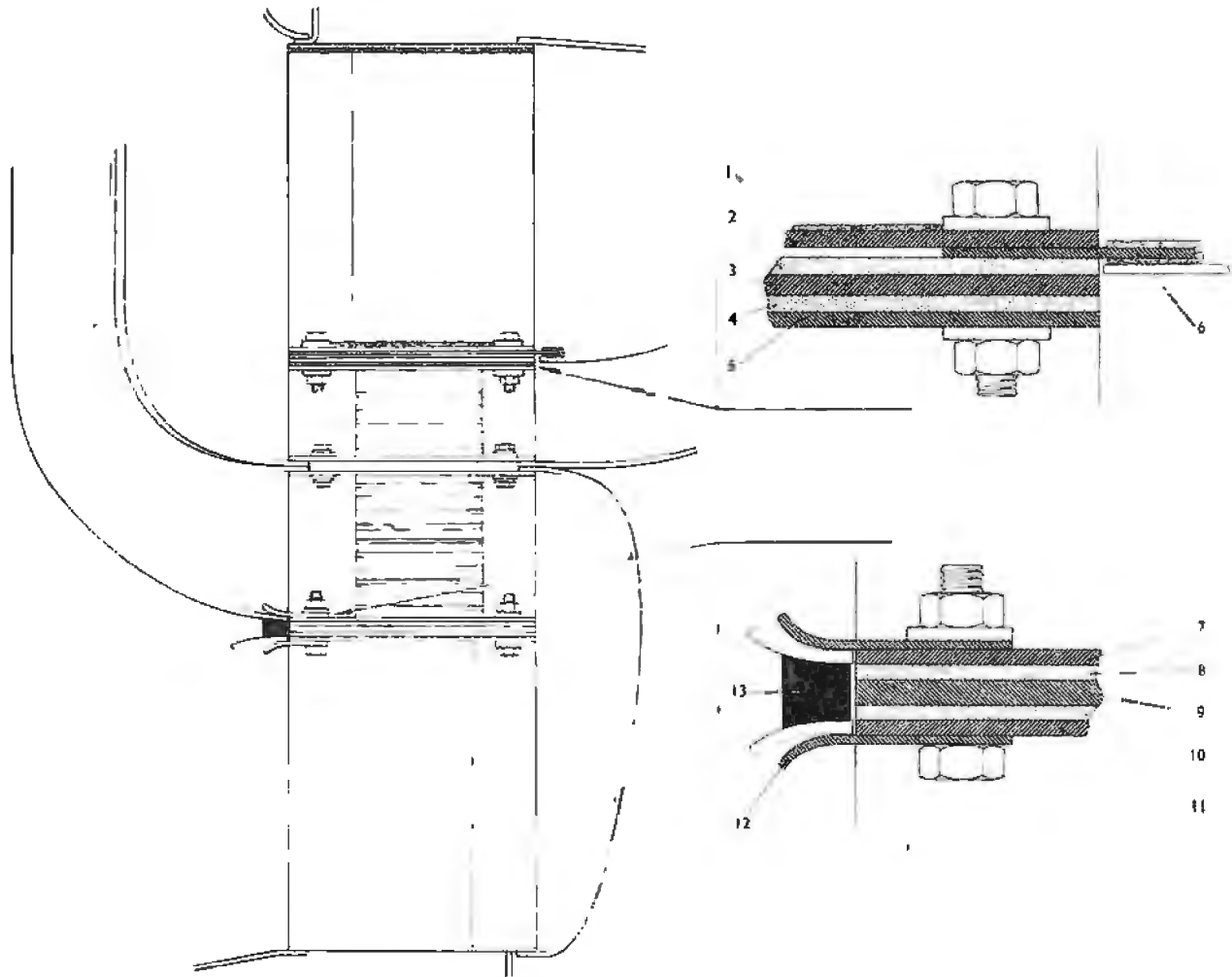

**Fig. C4 (S) Sectional view of heating unit**

C48

- 1 UPPER (DUMMY) EVAPORATOR
- 2 FEROBESTOS PACKING PIECE
- 3 UPPER SUPPORT BRACKET
- 4 FEROBESTOS PACKING PIECE

- 5 UPPER HEATER MATRIX
- 6 FELTED PACKING STRIP
- 7 LOWER HEATER MATRIX
- 8 FEROBESTOS PACKING PIECE
- 9 LOWER SUPPORT BRACKET

- 10 FEROBESTOS PACKING PIECE
- 11 LOWER (DUMMY) EVAPORATOR
- 12 RETAINER PLATE
- 13 RUBBER SEALING STRIP

**Underwing unit — To dismantle**  
(Page C 11 in Workshop Manual)

For S3 cars the third paragraph to read  
Remove the eighteen nuts, bolts and washers securing the four sections of the matrix block together; separate the sections and retain the packing strips and brackets held between them.

**Underwing unit — To assemble**  
(Page C 13 in Workshop Manual)

**S3 cars only**

Fit the 'Ferobestos' packing piece between the 'Upper' and 'Lower' matrices, positioning the 'Upper' matrix so that the outlet or straighter of the two pipes face

towards the valance plate; then using six nuts, bolts and twelve plain and 'Ferobestos' washers bolt the two matrices together as shown in Figure C4 (S) of this Supplement.

Continue to assemble the heating unit, following the procedure described on page C13 in Workshop Manual.

**For S3 cars the first to fourth paragraphs to read**

Fit the main support brackets to the heater matrix block, fitting one of the thinner 'Ferobestos' packing pieces between the upper support bracket and the matrix block, and another one between the lower support bracket and matrix block. The upper bracket is the one with the larger flange.

Fit the upper 'dummy' evaporator above the matrix and bracket placing a thin 'Ferobestos' packing between the evaporator and the bracket. Ensure that the diagonal stiffener of the upper 'dummy' evaporator is to the rear of the assembly as shown in Figure C4 (S) of this Supplement. Refit the felt covered sealing strip between the evaporator and the 'Ferobestos' packing pieces as shown in Figure C4 (S) of this Supplement. If a new felted strip is fitted, the outer edge must be trimmed to fit the ducting; then using six  $\frac{1}{4}$  in. nuts, bolts and plain washers, bolt the assembly together.

Repeat the above procedure with the lower 'dummy' evaporator noting that in this case the diagonal stiffener must be to the front of the assembly. Two 'Ferobestos' packing pieces are used, one each side of the mounting bracket, and in addition two curved plates are bolted along the lower edge of the matrix to locate and secure the rear ducting as shown in Figure C4 (S) of this Supplement.

Attach the three ducts to the rear of the matrix block, fitting the edges of the ducts into the slots formed in the matrix block. Coat the adjacent surfaces of the lower two ducts with Bostik adhesive, then press a  $9\frac{3}{4}$  in. length of rubber sealing strip between them to wedge the ducts into position.

**For S3 cars the eighth paragraph to read**

Fit the forward pair of ducts to the matrix block, ensuring that the lower edge of the upper duct and the upper edge of the lower duct fit into the slot formed in the matrix block. Secure the ducting to the matrix block with self-tapping screws and reinforcement strips.

**Underwing unit — To fit**

(Page C 13 in Workshop Manual)

**For S3 cars the following two paragraphs should be read in place of the fourth.**

Connect the coolant hoses to the pipes of the heater matrices; the hose from the water tap on the right-hand valance should be connected to the lower pipe on the 'Lower' heater matrix. The hose from the water tap on the left-hand valance should be connected to the 'Upper' heater matrix. The 'Upper' heater matrix return pipe is connected to the matrix inside the engine compartment.

Secure the hoses with worm drive clips. When fitting the clips, position the screwdriver slots so that when the wing is in position, it will be possible to remove the heater hoses.

## ACTUATORS

**Description**

(Page C 15 in Workshop Manual)

**For S3 cars the fifth paragraph to read**

The water tap actuators are situated low down, at the forward end of both the left and right-hand valance plates. Figure C18 in the Workshop Manual shows the water tap which is situated on the right-hand valance and controls the flow of hot coolant to the 'Lower' heater matrix.

**Actuators — To adjust**

(Page C 15 in Workshop Manual)

**For S3 cars the fourth to eighth instructions inclusive are not applicable.**

**Evaporator flap (Upper) actuator —**

**To adjust**

(Page C 16 in Workshop Manual)

**S3 cars only**

- 1 Push the extension spindle fully 'home' into the flap conpling tube, then tighten the pinch bolt securing the crank lever to the extension spindle.

- 2 Withdraw the extension spindle and crank lever about  $\frac{1}{16}$  in., then tighten the grubscrews securing the collar against the end face of the spindle bearing tube.
- 3 Remove the crank lever from the actuator gear shaft and check that the extension spindle is free to rotate through  $90^\circ$ . Any movement through more than  $90^\circ$  indicates that the flap coupling tube is not engaged with the extension spindle dogs and requires rectification.
- 4 Switch on the ignition and turn the 'Upper' and 'Lower' switches to their off positions. Allow approximately 30 seconds for the actuator to return to the fully closed position.
- 5 Position the actuator crank lever so that it points to the No. 1 position on the actuator motor casing, then tighten the pinch bolt.
- 6 Slacken the pinch bolt securing the crank lever on the flap extension spindle. Turn the extension spindle anti-clockwise (when viewed over the left-hand wing) to close the flap valve. With the flap valve held closed, adjust the position of the extension spindle crank lever so that the link arm between the two crank levers can just be fitted under slight tension. Fit new split pins on the link arms.

### Heater flap (Lower) actuator — To adjust (Page C 16 in Workshop Manual)

#### S3 cars only

Repeat the operations 1-4 as described for the evaporator flap.

- 5 Position the actuator crank lever so that it points to the No. 3 position on the actuator motor casing. Tighten the pinch bolt.

- 6 Slacken the pinch bolt securing the crank lever on the flap extension spindle. Turn the extension spindle clockwise (when viewed over the left-hand wing) to close the flap valve. With the flap valve held closed, adjust the position of the extension spindle crank lever so that the link arm between the crank levers can just be fitted under slight tension. Fit new split pins on the link arms.

### Water tap opening — To check

#### S3 cars only

To ascertain that the water taps are closed, turn both the 'Upper' and 'Lower' airstream switches to either the 'Off' or one of the anti-clockwise positions, wait 30 seconds to allow the actuator motor to operate and then return the switches to the 'Off' position. Before continuing the check, allow sufficient time for the coolant in the heater matrices to cool; to facilitate this turn both the 'Upper' and 'Lower' airstream switches to the second anti-clockwise position, withdrawing the 'Upper' airstream switch to its full extent. This action causes the blower motor to operate, thereby cooling the heater matrices. After a sufficient time period return the switches to their 'Off' position.

If the taps are closed and the engine is warm, the three pipes which lead to the heater matrices under the right-hand front wing should be cold; if one of the taps is leaking then the pipes will be warm. The pipe which is connected to the 'Upper' heater matrix is in turn connected to the water tap on the left-hand valance. The two pipes connected to the 'Lower' heater matrix are in turn connected to the water tap on the right-hand valance.

If the pipes are warm, adjust each water tap in turn using the following procedure.

### 'Lower' water tap — To check

#### S3 cars only

- 1 Drain the coolant into a suitable container, or disconnect the two pipes connected to the water tap on the right-hand valance and plug them with suitable wooden pegs to prevent any loss of coolant.

- 2 Close the water tap by turning the 'Lower' air-stream switch anti-clockwise and waiting 30 seconds, then turn the switch back to the 'Off' position.
- 3 If the coolant has been drained, disconnect the two hoses to the water tap. Remove the four bolts securing the tap and actuator motor to the wing valance, then lift out the tap.
- 4 Check whether the tap is open or closed by passing air through the tap from the inlet side.
- 5 If the tap is not properly closed, slacken the clamping bolt on the actuator and push the tap lever to the closed position. Hold the lever in the closed position and tighten the clamping bolt.
- 6 Check the functioning of the tap, and if correct, fit the tap and actuator motor on the wing valance.

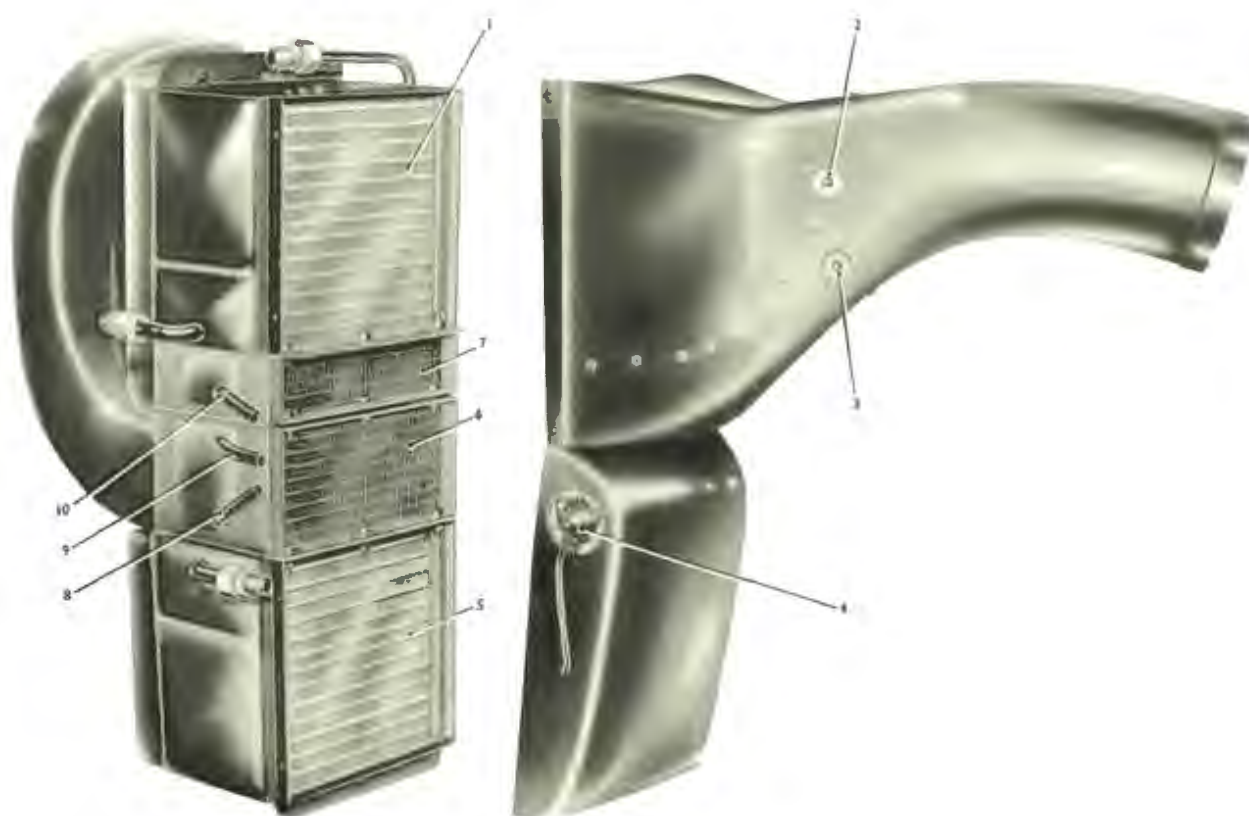

Fig. C5 (S) Access to matrices

- |                           |                              |
|---------------------------|------------------------------|
| 1 UPPER EVAPORATOR MATRIX | 6 LOWER HEATER MATRIX        |
| 2 COLD FLAP SPINDLE       | 7 UPPER HEATER MATRIX        |
| 3 HOT FLAP SPINDLE        | 8 LOWER HEATER MATRIX INLET  |
| 4 THERMOSTATIC SWITCH     | 9 LOWER HEATER MATRIX OUTLET |
| 5 LOWER EVAPORATOR MATRIX | 10 UPPER HEATER MATRIX INLET |

### **'Upper' water tap — To check**

#### **S3 cars only**

Repeat the operations described for the 'Lower' water tap, noting that the 'Upper' airstream switch controls the 'Upper' tap actuator and that the tap and actuator

motor are mounted low down at the forward end of the left-hand valance plate.

Figures C13, C14, C15 and C16 in the Workshop Manual are not applicable to the S3 Air Conditioning Unit.

The remaining information in this Section which applies to S2 cars is also applicable to S3 cars.



# CHAPTER D

## LUBRICATION AND MAINTENANCE

SECTION	PAGE
D 1 Maintenance Data—S3 Cars . . . . .	D1 (S)

## CHAPTER D

## LUBRICATION AND MAINTENANCE

## SECTION D1—MAINTENANCE DATA

## SILVER CLOUD III, BENTLEY S3, BENTLEY CONTINENTAL S3 AND PHANTOM V

**Engine**Silver Cloud III, Bentley S3 and  
Continental S3

Distributor contact breaker gap	0.014 in. — 0.016 in.
Distributor 'dwell' angle	31° to 37° at 0.015 in. gap
Sparking plugs	
9 : 1 compression ratio	Champion RN.8.
8 : 1 compression ratio	Champion RN.8, Champion RN.13P, Lodge CLNP.
Sparking plug gap	0.025 in.
Firing order	A1, B1, A4, B4, B2, A3, B3, A2. ( 1, 5, 4, 8, 6, 3, 7, 2.)
Ignition timing	2° B.T.D.C.
Valve timing	5° A.T.D.C.

**Engine**

Phantom V

Distributor contact breaker gap	0.019 in. — 0.021 in.
Distributor 'dwell' angle	31° to 32½° at 0.020 in. gap
Sparking plugs	
9 : 1 compression ratio	Champion RN.8.
8 : 1 compression ratio	Champion RN.8, Champion RN.13P, Lodge CLNP.
Sparking plug gap	0.025 in.
Firing order	A1, B1, A4, B4, B2, A3, B3, A2. ( 1, 5, 4, 8, 6, 3, 7, 2.)
Ignition timing	2° B.T.D.C.
Valve timing	5° A.T.D.C.

**Capacities**

	Imperial	U.S.	Litres
Engine	12 pints	14.4 pints	6.81
Automatic gearbox	20 pints	24 pints	11.36
Rear axle — Silver Cloud III	1 $\frac{5}{8}$ pints	1.95 pints	0.92
Bentley S3			
Continental S3			
Phantom V			
Steering system	3 pints	3.6 pints	1.7
Steering (transfer box)	$\frac{5}{8}$ pints	0.75 pints	0.355
Cooling system	22 pints	26.41 pints	12.5
Fuel tank — Silver Cloud III	18 galls.	21.6 galls.	81.82
Bentley S3			
Continental S3			
Phantom V			
	23 galls.	27.62 galls.	104.56

**Levels**

Engine sump	Maximum mark on dipstick
Automatic gearbox	F line on dipstick
Rear axle	Bottom of level plug orifice
Steering system	Just covering the filter
Steering (transfer box)	Bottom of level plug orifice
Shock dampers	Bottom threads of filler plug orifice
Hydraulic brake fluid reservoirs	Level marks on clamping straps
Coolant level	Bottom of radiator filler orifice
Battery electrolyte	$\frac{3}{8}$ in. above the top of separators
Windscreen washer reservoir	1 in. below the top of filler orifice

**Tyre pressures**

Silver Cloud III and Bentley S3 — 8.20 in. × 15 in. tyres	Front 22 lb/sq.in. (1.55 kg/sq.cm.)	} Cold
	Rear 27 lb/sq.in. (1.90 kg/sq.cm.)	
Silver Cloud III and Bentley S3 Long Wheelbase — 8.20 in. × 15 in. tyres	Front 23 lb/sq.in. (1.62 kg/sq.cm.)	} Cold
	Rear 29 lb/sq.in. (2.04 kg/sq.cm.)	
Bentley Continental S3 — 8.00 in. × 15 in. tyres	Front 20 lb/sq.in. (1.41 kg/sq.cm.)	} Cold for normal speed running.
	Rear 25 lb/sq.in. (1.76 kg/sq.cm.)	
	Front 25 lb/sq.in. (1.76 kg/sq.cm.)	} Cold for maximum speed running.
	Rear 30 lb/sq.in. (2.11 kg/sq.cm.)	
Park Ward Convertible Coupe — 8.00 in. × 15 in. tyres	Front 20 lb/sq.in. (1.41 kg/sq.cm.)	} Cold for normal speed running.
	Rear 28 lb/sq.in. (1.97 kg/sq.cm.)	
	Front 25 lb/sq.in. (1.76 kg/sq.cm.)	} Cold for maximum speed running.
	Rear 33 lb/sq.in. (2.33 kg/sq.cm.)	
Phantom V — 8.90 in. × 15 in. tyres	Front 22 lb/sq.in. (1.55 kg/sq.cm.)	} Cold
	Rear 27 lb/sq.in. (1.90 kg/sq.cm.)	

**Note** The tyre pressures quoted for Phantom V cars are nominal figures only, as the pressures may vary between individual cars according to the weight.

**Electrical equipment**

Battery	Dagenite or Exide 12v. 67 amp/hr.
Earth	Negative to frame
Generator	Lucas C48 12v.
Starter motor	Lucas M-45 G 12v.
Horns	Lucas WT 618/1
Headlamps	Twin sealed-beam type

**Headlamp type and ratings**

	Type	Rating	Colour	Fitting
U.K.	1A	12v 37½w	Clear	Push-in two blade
	2A	12v 37½/50w	Clear	Push-in three blade
Europe, except France	1A	12v 37½w	Clear	Push-in two blade
	European	12v 45/40w	Clear	Push-in three blade
France	1A	12v 37½w	Yellow	Push-in two blade
	2A	12v 45/40w	Yellow	Push-in three blade
Middle and Far East	1A	12v 37½w	Clear	Push-in two blade
Canada, South and America U.S.A. }	2 or 2A	12v 37½/50w	Clear	Push-in three blade

**Bulbs****Foglamps**

All countries except U.S.A. and Canada	12v 48w	Yellow	B.P.F.
U.S.A. and Canada	12v 48w	Clear	B.P.F.
Front side lamp	12v 6w	Clear	M.C.C. bayonet
Front flasher lamp	12v 21w	Clear	S.C.C. bayonet
Rear stop/tail lamp	12v 21/6w	Clear	S.B.C. bayonet
Rear flasher lamp	12v 21w	Clear	S.C.C. bayonet
Reversing lamp	12v 21w	Clear	S.C.C. bayonet
Number plate lamp	12v 6w	Clear	M.C.C. bayonet
Boot lamp	12v 6w	Clear	M.C.C. bayonet
Inspection lamp	12v 6w	Clear	M.C.C. bayonet
Companion lamp	12v 6w	Clear	M.C.C. bayonet
Map lamp	12v 6w	Clear	M.C.C. bayonet
Roof lamp	12v 6w	Clear	Double-ended festoon
Capping rail lamp	12v 3w	Clear	Double-ended festoon
Speedometer			
Illumination	12v 2·2w	Clear	M.E.S. screw
Flasher warning lamps	12v 2·2w	Clear	M.E.S. screw
Headlamp main beam	12v 2·2w	Clear	M.E.S. screw
'4' in '1' instrument lamp	12v 2·2w	Clear	M.E.S. screw
Clock illumination	12v 2·2w	Clear	M.E.S. screw
Hand brake warning lamp	12v 2·2w	Clear	M.E.S. screw
Switchbox			
Generator warning lamp	16v 3w	Clear	M.E.S. screw
Fuel level warning lamp	16v 3w	Clear	M.E.S. screw

**Fuses**

	30 amp. (one strand of No. 28 SWG (0·0148 in. dia.) tinned copper wire).
Horn fuse	25 amp. cartridge type
Headlamp flasher relay	25 amp. cartridge type
Radio fuse	5 amp. cartridge type

**PERIODIC LUBRICATION AND MAINTENANCE****SCHEDULES FOR****SILVER CLOUD III, BENTLEY S3, BENTLEY CONTINENTAL S3 AND PHANTOM V**

The following periodic service schedules have been drawn up to assist retailers and service personnel with the maintenance of Rolls-Royce and Bentley motor cars.

Retailers are advised to adopt these schedules as normal service procedure and to make appropriate arrangements with any owners wishing to avail themselves of this service.

Should some owners wish to carry out their own maintenance inspections, it should be noted that these schedules do not in any way supersede the instructions given in the Owner's Handbook.

**INITIAL 3,000 MILE SCHEDULE**

At the completion of the first 3000 miles (5000 Kms.) Engine oil change. Oil level checks, engine and chassis adjustments, electrical system checks and road test.

**6000 MILE SCHEDULE**

At the completion of every 6000 miles (10,000 Kms.).

Repetition of the 3000 mile schedule plus — Engine oil change — engine oil filter change — brake system check — minor engine, chassis and electrical system checks and lubrication.

**12,000 MILE SCHEDULE**

At the completion of every 12,000 miles (20,000 Kms.).

Repetition of the 6000 mile schedule plus — Complete lubrication of suspension, steering and transmission — further maintenance of engine, chassis and electrical system components.

**24,000 MILE SCHEDULE**

At the completion of every 24,000 miles (40,000 Kms.).

Repetition of the 12,000 mile schedule plus — change of major components — maintenance of power assisted steering unit.

**INITIAL 3000 MILE (5000KM.) SCHEDULE****Oil changes**

- 1 Drain and refill the crankcase sump. For subsequent oil changes refer to the 6000 mile schedule.

**Oil level checks and lubrication**

- 1 Carburetter air valve damper.
- 2 Steering pump reservoir.
- 3 Brake fluid reservoirs.
- 4 Automatic gearbox. (Check with the engine running as described in the Automatic Gearbox Manual.)
- 5 Lubricate the eight grease nipples on the front suspension.

**Engine and chassis adjustments**

- 1 Check the coolant level and if necessary top-up with the correct anti-freeze mixture. Tighten the worm drive clips securing all coolant hoses.
- 2 Check the tension of the belts driving the fan, steering pump, generator and refrigerant compressor (if fitted) and adjust if necessary. If individual belt tension is uneven a new matched pair of belts should be fitted.
- 3 Check and if necessary adjust the rear brakes and servo.
- 4 Check and adjust tyre pressures (including spare).

**Electrical system checks**

- 1 Check the level of the battery electrolyte and top-up if necessary.
- 2 Check, and if necessary top-up the windscreen washer reservoir with the correct mixture of distilled water and Rolls-Royce windscreen washer fluid.

**Road test**

- 1 Test the car on the road and adjust the T.V. rod ('A' rod) if necessary.

**6000 MILE (10,000 KM.) SCHEDULE**

- 1 Repeat the 3000 mile schedule.

**Oil changes**

- 1 Drain and refill the crankcase.  
If the car is used regularly for town work and is subjected to a considerable amount of 'stop-start' operation, the engine crankcase should be drained and refilled every 3000 miles (5000 Kms.).

**Engine adjustments and checks**

- 1 Renew the oil filter element.
- 2 Clean the air valves in the carburetters.  
Check the oil level in the air valve dampers and top-up if necessary to the correct level.
- 3 Lubricate the ignition distributor automatic advance mechanism, shaft bearings, governor spindle and cam.
- 4 Clean the contact breaker points, check the gap and apply one drop of engine oil to the pivot pin of each rocker arm.  
Check and if necessary, reset the ignition timing.
- 5 Clean spark plugs and set gaps as necessary.
- 6 Remove, clean and re-oil the wire mesh air filter element.

**Chassis adjustments and checks**

- 1 Remove any foreign matter from the refrigerator condenser matrix (if fitted).
- 2 Lubricate the gear range selector controls and accelerator linkage.
- 3 Lubricate the brake system pivot pins and bearings.
- 4 Remove the brake drums and inspect the brake linings for wear. The face of a lining should not be less than  $\frac{1}{16}$  in. above the rivets.
- 5 Interchange the wheels to minimise variations in tyre wear.
- 6 Check and if necessary balance the wheels.

**Electrical system**

- 1 Check that the heater controls are operating satisfactorily.
- 2 Check that all lights, flasher units and instruments are operating satisfactorily.

**12,000 MILE (20,000 KM.) SCHEDULE**

- 1 Repeat the 6000 mile schedule.

**Oil level checks**

- 1 Check the shock absorbers for signs of leakage; if apparent, inspect the oil level and top-up if necessary with the recommended oil.
- 2 Check and if necessary, top-up the rear axle with oil.

**Engine adjustments and checks**

- 1 Renew the sparking plugs.
- 2 Renew the carburetter air filter element — this only applies where the paper type air filter element is fitted (certain overseas countries only).
- 3 Clean the gauze filters and the carburetter float chamber feed connections.

**Chassis adjustments and checks**

- 1 Lubricate the grease nipple on the master cylinder balance lever.
- 2 Lubricate the thirteen grease nipples on the steering mechanism.
- 3 Lubricate the eight grease nipples on the front suspension.
- 4 Lubricate the three grease nipples on the rear propeller shaft.
- 5 Clean out the main fuel line filter and filter bowl and the filter gauzes in the fuel pump. Clean the electrical contact points and check the functioning of the fuel pumps. (Each pump should be tested independently.)

**Electrical system checks**

- 1 Clean, apply vaseline and tighten the battery terminals.

**Heater (recirculatory)**

- 1 Clean the filter gauze in the intake beneath the right-hand front seat. Test the car on the road.

**24,000 MILE (40,000 KM.) SCHEDULE**

- 1 Repeat the 12,000 mile schedule.

**Oil changes**

- 1 Drain the gearbox and fluid coupling; refill with the recommended fluid.
- 2 Drain and refill the rear axle.

**Oil level checks**

- 1 Check the oil level in the transfer steering box and top-up if necessary.

### **Engine adjustments and checks**

- 1 Clean the flame traps in the crankcase breather tube.

### **Chassis adjustments and checks**

- 1 Renew the filter element in the steering pump reservoir.
- 2 Release, but do not remove the fuel tank drain plug to allow any accumulated water to escape.

### **Electrical system checks**

- 1 Inspect the generator commutator and brushes for wear and for freedom in their holders.

### **SEASONAL SCHEDULES**

#### **Every 12 months**

##### **Engine cooling system**

- 1 Drain the anti-freeze from the radiator and both cylinder blocks. Thoroughly flush out the coolant passages with a continuous flow of water. This should be carried out just prior to the Autumn. (In the U.K. prior to September 21st.)  
Refill the system with the correct anti-freeze mixture.

### **Refrigeration system (if fitted)**

**These operations should only be carried out by an experienced refrigeration engineer.**

Check that the refrigeration system is functioning correctly and if necessary top-up the system with refrigerant. If loss of refrigerant is evident, check the system for leaks.

Check the level of oil in the refrigerant compressor.

Clean the filter gauze fitted over the evaporator air intake (boot units only).

#### **Every 24 months**

Repetition of 12 months schedule plus —

Renewal of heater and coolant hoses.

### **SPECIAL PRECAUTIONS**

Should the car be used in constant temperatures of 0°F. and below

#### **Carburettors**

Drain and refill the carburetter air valve dampers with oil of viscosity S.A.E. 10.

#### **Engine**

Drain the engine sump when thoroughly warm and refill with oil of viscosity S.A.E. 10.

# CHAPTER G

## BRAKING SYSTEM

SECTION		PAGE
G 1	Data and General Description . . . . .	G1 (S)
G 4	Servo Motor . . . . .	G1 (S)
G 5	Brake Shoes, Drums and Expander Mechanism	G1 (S)
G 7	Basic Adjustment of Brake Rods and Linkages	G2 (S)



## CHAPTER G

# BRAKING SYSTEM

### SECTION G 1 — DATA AND GENERAL INFORMATION

#### **Four shoe brake system — Front brakes** (Page G 3 in Workshop Manual)

The fitting of four shoe brakes to Bentley Continental cars has been discontinued from Chassis No. BC164XA and replaced by two shoe brakes as fitted to standard S2 and S3 cars.

The information in this Section which applies to Bentley Continental S2 cars is also applicable to Bentley Continental S3 cars to Chassis No. BC164XA inclusive.

The information in this Section which applies to S2 cars is also applicable to S3 cars and Bentley Continental S3 cars from Chassis No. BC166XA inclusive.

### SECTION G 4 — SERVO MOTOR

#### **Servo cam angle on Bentley Continental S2 and late S1 cars** (Page G 16 in Workshop Manual)

The information in this Section which applies to Bentley Continental S2 cars is also applicable to Bentley Continental S3 cars to Chassis No. BC164XA inclusive.

#### **On S2 and Phantom V cars**

The information in this Section which applies to S2 cars is also applicable to S3 cars and Bentley Continental S3 cars from Chassis No. BC166XA inclusive.

### SECTION G 5 — BRAKE SHOES, DRUMS AND EXPANDER MECHANISM

#### **Front brakes — To dismantle** (Page G 17 in Workshop Manual)

The information in the first paragraph of this Section which applies to Bentley Continental S2 cars is also applicable to Bentley Continental S3 cars to Chassis No. BC164XA inclusive.

The remaining information in this Section which applies to S2 cars is also applicable to S3 cars and

Bentley Continental S3 cars from Chassis No. BC166XA inclusive.

#### **Front brakes — To dismantle Bentley Continental S2** (Page G 25 in Workshop Manual)

The information in this Section which applies to Bentley Continental S2 cars is also applicable to Bentley Continental S3 cars to Chassis No. BC164XA inclusive.

**SECTION G7 — BASIC ADJUSTMENT OF BRAKE RODS AND LINKAGES**

**Hand brake warning lamp—Description**

A warning lamp is fitted to all present production cars to indicate to the driver that the hand brake is either 'on' or 'off'. The warning lamp is operated by a micro-switch mounted on a bracket on the chassis frame behind the hand brake operating lever. For the warning lamp to function correctly, it is essential that when the hand brake is applied, the light comes on before the hand brake reaches the first notch on the ratchet. Any warning lamp which is incorrectly set should be adjusted as follows

**Hand brake warning lamp — To adjust**

With the hand brake in the 'off' position and with the button on the micro-switch held down, the micro-switch should be adjusted so that a 0.060 in. gap is obtained between the button and the hand brake operating lever.

After carrying out the adjustment, check to ensure that the warning light comes on before the first notch on the hand brake is reached.

The remaining information in this Section which applies to S2 cars is also applicable to S3 cars.

# CHAPTER H

## SUSPENSION

SECTION		PAGE
H 1	Front Suspension	H1 (S)
H 6	Upper and Lower Triangle Levers and Stub Axle Yokes	H1 (S)

## CHAPTER H

# SUSPENSION

### SECTION H 1 — FRONT SUSPENSION

#### FRONT SUSPENSION DATA

#### **S2 cars**

(Page H 1 in Workshop Manual)

For S3 cars, castor angle to read 1° positive.

#### SECTION H 6

#### **Upper and lower triangle levers and stub axle yokes — S2 cars**

(Page H 17 in Workshop Manual)

The stub axle yokes fitted on S3 cars are machined to provide a castor angle of 1° positive. These yokes are

for use with the lighter steering introduced on S3 cars and are not interchangeable with the stub axle yokes fitted on S1 and S2 cars.

The remaining information in this Chapter which applies to S2 cars is also applicable to S3 cars.

# CHAPTER K

## FUEL SYSTEM AND CARBURETTERS

SECTION		PAGE
K 1	Fuel System . . . . .	K 1(S)
K 2	Fuel Pumps . . . . .	K 1(S)
K 3	Air Cleaners . . . . .	K 3(S)
K 4	The Carburetter and Automatic Choke System	K 3(S)
K 5	Throttle Valve Control Linkage Settings . . .	K 6(S)

## CHAPTER K

# FUEL SYSTEM AND CARBURETTORS

### SECTION K1 — FUEL SYSTEM

#### **Fuel tank** (Page K2 in Workshop Manual)

For S3 cars the paragraph headed 'All cars' to read  
A vent pipe is fitted to the top of the fuel tank; the pipe is connected by a length of rubber hose to a further vent pipe which is fitted in the filler tube assembly. This eliminates the possibility of an air lock forming, when the tank is being filled.

#### **Fuel tank — To remove and fit** (Page K3 in Workshop Manual)

For S3 cars the seventh and eighth paragraphs to read  
Allow the tank to drop sufficiently for the rubber hose connected to the tank vent pipe to be removed. Remove the tank together with the fabric packing strips.

To fit the fuel tank, reverse the procedure adopted for its removal, making sure that the rubber hose is connected to the vent pipe as the tank is lifted into position.

### SECTION K2 — THE FUEL PUMPS

#### **Test data** (Page K6 in Workshop Manual)

On S3 cars both pumps operating together deliver 1 pint of paraffin in 28 seconds at a delivery head of 4 ft. and a suction lift of 2 ft. 6 in.

Mount the pump on a test rig 2 ft. 6 in. above a paraffin bath. Fit  $\frac{1}{8}$  in. bore pipes to both the inlet and outlet unions of the pump; immerse the pipe

connected to the inlet union in the paraffin bath and suspend the pipe connected to the outlet union 4 ft. above the pump unit. A measuring jar or receptacle of known capacity should be placed beneath the outlet union, and the delivery of the pump checked against a stopwatch.

The remaining information in this Section which applies to S2 cars is also applicable to S3 cars.

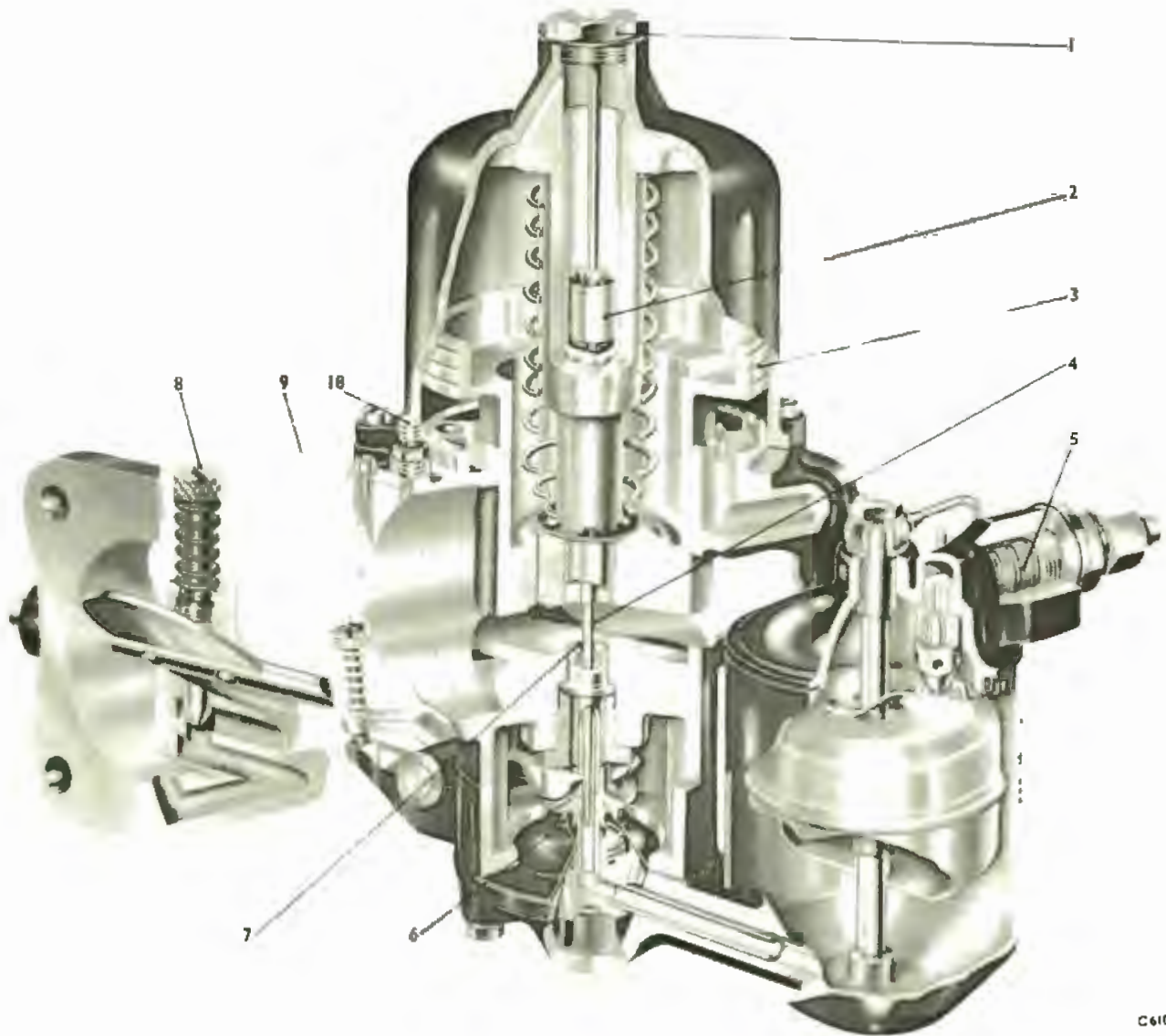

C610

**Fig. K1 (S) Cut-away view of one carburetter**

1 OIL RESERVOIR CAP

2 HYDRAULIC DAMPER PISTON

3 AIR VALVE PISTON

4 NEEDLE

5 FILTER

6 DIAPHRAGM

7 JET

8 VOLUME ADJUSTMENT SCREW

9 JET ADJUSTMENT SCREW

10 VACUUM PIPE UNION

**K2 (S)**

## SECTION K3—AIR CLEANERS

**S2 cars**  
(Page K7 in Workshop Manual)**S3 cars only**

The air filter and silencer unit fitted may be either an oil soaked wire mesh element or a 'Purolator' paper element depending upon the destination of the car.

All cars destined for the following countries are fitted with a Purolator paper air filter element:

Africa (including Algeria, Egypt, Kenya, South Africa, Morocco, Sudan, Tunisia, Madeira, Tangiers, Nigeria, etc.) also Asia (including India, Turkey, Iran, Iraq, Syria, Lebanon, Israel, Jordan, Hong Kong, etc.) also Australia, New Zealand, Spain, Portugal, Greece, Yugoslavia, Gibraltar, South America, Jamaica, Bahamas and Mexico.

The Purolator element of this filter should be renewed every 12,000 miles (20,000 Kms.).

All cars destined for countries other than those previously listed are fitted with an oil wetted wire mesh air filter element.

Every 6000 miles (10,000 Kms.) the filter should be removed and washed thoroughly in petrol.

After washing, all surplus petrol should be removed by blowing through the filter from the inside with a high pressure air line.

The filter should then be completely immersed in engine oil and allowed to soak for a period of approxi-

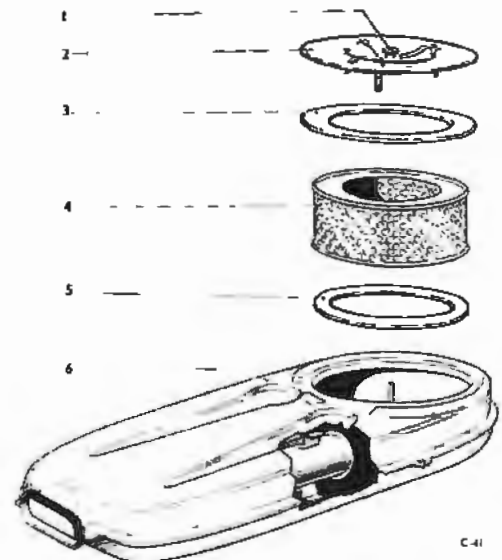

Fig. K2 (S) Exploded view of air filter

- |                |                  |
|----------------|------------------|
| 1 KNURLED NUT  | 4 FILTER ELEMENT |
| 2 COVER        | 5 JOINT WASHER   |
| 3 JOINT WASHER | 6 SILENCER       |

mately five minutes and afterwards allowed to drain for a period of two hours.

Refit the element to the silencer.

## SECTION K4—THE CARBURETTER AND AUTOMATIC CHOKE SYSTEM

**Data**  
(Page K9 in Workshop Manual)**S3 cars only**

Carburetter S.U. HD8 diaphragm type  
Choke size 2.00 in. (50.80 mm.) dia. bore.  
Jet size 0.125 in.  
Jet needle U.S.

**S3 cars only**

Two HD8 diaphragm carburetters with 2.00 in. choke bores are fitted to the engine on a central 'Tee' piece which is mounted over an eight-branch induction manifold.



Whilst operating on the same principles as the HD6 carburetter fitted to the S2 engine, the HD8 carburetter embodies a number of differences. The choke bore has been increased in size to 2.00 in. and a larger jet fitted, these two features allow the engine to produce greater power, and by careful adjustment and attention to detail, to achieve a higher standard of economy.

Apart from the increased choke bore and resultant general increase in size, a tapping has been provided immediately above the butterfly closed position on the 'A' bank carburetter. This tapping, shown in Figure K1 (S), is provided to operate the vacuum timing control fitted to the distributor.

### Carburetters — To remove S2 cars (Page K13 in Workshop Manual)

**For S3 cars this paragraph to follow the eighth paragraph.**

Remove the closed circuit engine breather from the butterfly housing and from the oil filler pedestal.

### Carburetters — To fit

#### S3 cars only

To fit the carburetters reverse the procedure given for removal noting the following points.

New gaskets to be fitted to all the joints.

Clean the flame traps in the crankcase breather tube by washing them in petrol and drying them with a high pressure air line.

Before refitting the union to the oil filter pedestal check the condition of the rubber sealing ring and renew if necessary.

### Automatic choke system (Page K16 in Workshop Manual)

**For S3 cars the fourth feature to read**

A 'fast-idle' cam, loose coupled to a pick-up lever which is in turn connected to the butterfly spindle. The 'fast-idle' cam has only two steps, the second of which is tapered to provide a progressive closing of the throttle.

### 'Fast-idle' cam (Page K18 in the Workshop Manual)

**For S3 cars the second paragraph onward to read**

Remove the 'fast-idle' adjusting screw and ensure that a clearance of approximately  $\frac{1}{16}$  in. exists between the cam link which is mounted alongside the 'fast-idle' cam and the boss on the carburetter 'fast-idle' lever.

Insufficient clearance at this point could result in the cam link fouling the 'fast-idle' lever. In the event of this happening the 'fast-idle' lever would be prevented from returning to the throttle closed position, thus causing a fast idling speed.

Ensure that the throttles are closed.

Screw down the 'fast-idle' adjusting screw until it just makes contact with the high step of the cam.

Place a 0.100 in. drill between the short side of the choke butterfly and the choke housing, as for setting the kick-gap.

With this drill in position adjust the length of butterfly rod so that the tip of the 'fast-idle' screw rests on the edge of the high step of the cam (i.e. the position when the tip of the adjusting screw is about to fall from the high step to the low step).

Remove the 0.100 in. drill from the choke housing.

### Carburetter — To set (Page K19 in Workshop Manual)

**For S3 cars the fourth paragraph onward to read**

Screw down each idle bleed adjusting screw, shown in Figure K3 (S) of this Supplement, to the full extent of its travel, then unscrew  $1\frac{1}{2}$  turns.

The mixture strength is regulated by the jet adjusting screw, shown in Figure K3 (S) of this Supplement, which should be manipulated until the jet is level with the top of the bore in which it is located. Then screw the adjusting screw two complete turns down.

Fit the suction chambers and top-up the damper reservoir with oil. See Chapter D in this Supplement.

Run the engine until normal operating temperature is reached and carry out the final adjustment as follows.

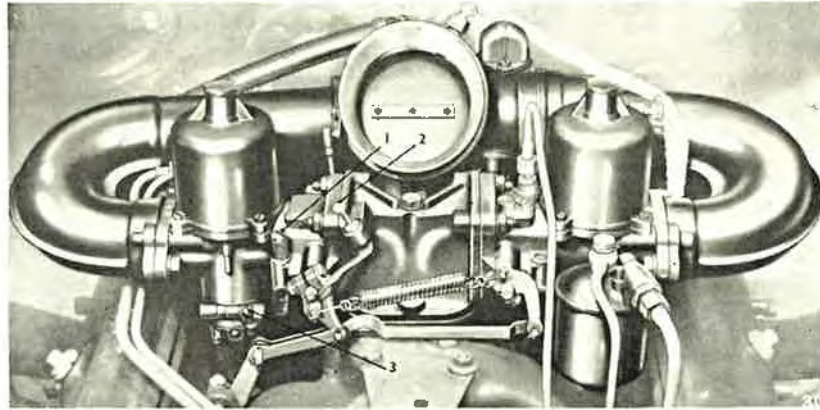

Fig. K3 (S) The carburetters

1 VOLUME ADJUSTMENT SCREW

2 THROTTLE STOP SCREW

3 JET ADJUSTMENT SCREW

### Slow running — To adjust

Engage the refrigeration compressor (if fitted).

Adjust the mixture control screw on each carburettor until the smoothest running of the engine is obtained. Turning the screw clockwise lowers the jet and richens the mixture; turning the screw anti-clockwise raises the jet and weakens the mixture.

Then using the volume screws balance the carburetters so that the hiss heard from each carburettor is of equal intensity. The volume screws should only be adjusted within the range, fully closed to two complete turns up, otherwise an obtrusive whistle from the carburetters may result.

After balancing the carburetters with the volume screws, adjust the slow running by means of the throttle stop screw to the maximum speed that will not cause the car to creep when in gear. This is usually in the order of 475 r.p.m. in neutral and 450 r.p.m. in gear. After adjusting the slow running speed, lock the throttle stop screw by means of the lock-nut.

### Cold start engine speed

(Page K21 in Workshop Manual)

**For S3 cars the following three paragraphs should be read in place of the eleventh**

Ensure that the gear change selector is in the neutral 'N' position.

Check to see that the 'fast-idle' adjusting screw is resting on the high step of the cam, then using the 'fast-idle' adjusting screw adjust the engine speed to 1850 r.p.m. Lock the adjusting screw by means of the lock-nut and recheck to ensure that the engine speed is still 1850 r.p.m. By slightly opening the throttles the cam will fall away; on releasing the throttles the engine will idle normally.

Where the engine is required to start below a temperature of 10°F. (−12°C.) the 'fast-idle' speed should be set to 2000 r.p.m.

The remaining information in this Section which applies to S2 cars is also applicable to S3 cars.

**SECTION K5 — THROTTLE VALVE CONTROL LINKAGE**

**Throttle valve control linkage settings**

(Page 21 in Workshop Manual)

**S3 cars**

Throttle valve control settings which apply to S2 cars are also applicable to S3 cars.

**The closed circuit engine breather — S3 cars**

The engine crankcase is ventilated through a breather pipe connected at one end to the rear of the oil filler pedestal and the other end to the choke butterfly housing. On a number of early S3 cars the breather pipe is connected on the engine side of the choke butterfly; on later S3 cars the pipe is positioned on the air cleaner side of the choke butterfly.

The breather pipe is of double skin construction with insulating material sandwiched between the two skins to prevent condensation forming on the inside of the tube.

A flame trap in the form of six gauze filters is incorporated in the union at the oil filler pedestal end of the breather tube. Every 24,000 miles, the filters in the flame trap should be removed and cleaned.

**Breather pipe — To remove**

Remove the setscrews securing the breather pipe union to the oil filter pedestal; disconnect the union from the pedestal (slight pressure may be felt owing to the rubber joint on the union).

Remove the setscrews securing the breather pipe to the choke butterfly housing.

Disconnect the pipe from the engine.

Remove from the pipe the union containing the flame trap.

Remove the filters and wash them in clean petrol, then dry them with a high pressure air line.

**Breather pipe — To assemble**

To assemble the crankcase breather pipe reverse the procedure given for its removal, noting the following points.

Before refitting the union to the oil filler pedestal check the condition of the rubber sealing rings and renew if necessary.

Check the condition of the sealing ring in the union at the choke butterfly housing end of the breather pipe; renew if necessary.

Check the aluminium washer on the centre securing bolt; renew if damaged.

# CHAPTER L

## ENGINE COOLING SYSTEM

SECTION		PAGE
L 1	Data . . . . .	L 1(S)
L 3	Radiator . . . . .	L 1(S)
L 4	Thermostat . . . . .	L 2(S)
L 5	Coolant Pump . . . . .	L 2(S)

## CHAPTER L

## ENGINE COOLING SYSTEM

## SECTION L 1 — DATA

(Page L 1 in Workshop Manual)

For S3 cars read as follows

Capacity	Imperial	U.S.	Litres
Silver Cloud III Bentley S3 Bentley Continental S3 Phantom V	22 pints	26.41 pints	12.50
	23 pints	27.60 pints	13.07
<b>Pump</b>	Centrifugal		
<b>Pump drive</b>	Twin belts	46.00 in. × 0.406 in.	
<b>Fan</b>	Five blade	18 in. diameter	
<b>Thermostat</b>	'Summer' opening temperature of 82°C to 86°C 'Winter' opening temperature of 87°C to 89°C		
<b>Radiator</b>	Fixed shutters		

## SECTION L 3 — RADIATOR

**Description**

(Page L 4 in Workshop Manual)

For S3 cars read as follows

The dimensions of the radiator matrices are as follows

	Surface area	Dimensions
Silver Cloud III and Bentley S3 Phantom V Continental S3	420.000 sq.in.	21.150 in. × 19.875 in. × 2.283 in.
	449.675 sq.in.	22.625 in. × 19.875 in. × 2.283 in.
	400.000 sq.in.	20.125 in. × 19.875 in. × 2.283 in.

**On all S2 cars**

(Page L4 in Workshop Manual)

For S3 cars the second paragraph is not applicable.

The remaining information in this Section which applies to S2 cars is also applicable to S3 cars.

## SECTION L 4 — THERMOSTAT

**Description**

(Page L6 in Workshop Manual)

**For S3 cars read as follows**

The thermostat comprises a cast body having a bridge piece on top; into this bridge piece is screwed a stud to act as a fixed piston. A dished valve, which seats on the underside of the thermostat body, incorporates a cylinder enclosing the piston, and carrying a wax filled capsule in its base. The valve is held in the closed position by a spring which is retained by a 'U' piece, the latter also serving as a guide for the cylinder.

The valve incorporates a vent hole containing a 'jiggle' pin. This vent allows air to escape while the cooling system is being replenished, thus avoiding air locks. When the system is operating, the 'jiggle' pin rises to close the vent against the passage of coolant.

An increase in coolant temperature causes the wax capsule to expand and force the valve downward off its seat.

A decrease in temperature causes the wax to contract and under the action of the spring the valve closes.

The valve is thus sensitive to the coolant temperature and controls the flow of coolant through the thermostat housing to suit the cooling requirements of the engine.

The bore of the coolant passage in the main body of the thermostat is 1.406 in. in diameter.

When the dished valve is closed, the by-pass valve is fully open, and allows the coolant to circulate around the engine only, excluding the radiator. The by-pass valve closes when the temperature reaches 93.3°C to 96.1°C, and allows all the coolant to pass through the radiator.

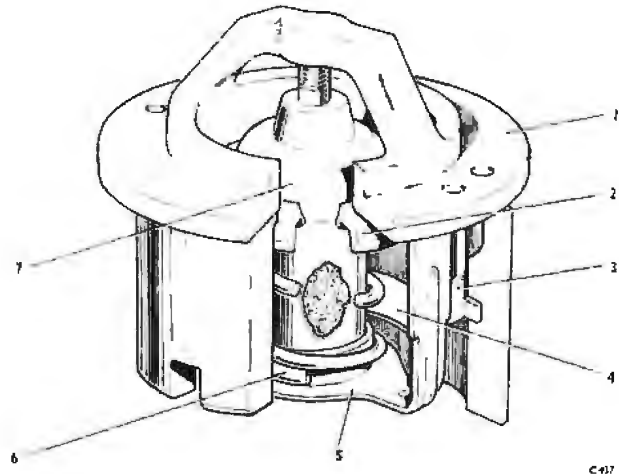

Fig. L1 (S) Sectional view of thermostat

- |                    |                                  |
|--------------------|----------------------------------|
| 1 THERMOSTAT BODY  | 5 'U' PIECE                      |
| 2 THERMOSTAT VALVE | 6 THERMOSTAT VALVE RETURN SPRING |
| 3 BY-PASS VALVE    | 7 WAX FILLED CAPSULE             |
| 4 BY-PASS PORT     |                                  |

**Thermostat — To test****On S2 cars**

(Page L8 in Workshop Manual)

On S3 cars, the thermostats are marked with their opening temperature range on the base of the wax filled bulb.

The standard thermostat unit is marked 82°C or 180°F. The by-pass valve is fully closed at 93°C to 96°C.

The thermostat provided for use in very cold conditions is marked 87.7°C or 190°F.

With this thermostat the by-pass valve fully closes at 98.8°C.

The remaining information in this Section which applies to S2 cars is also applicable to S3 cars.

## SECTION L 5 — COOLANT PUMP

(Page L8 in Workshop Manual)

All information which applies to the S2 coolant pump is also applicable to the S3 coolant pump.

# CHAPTER M

## ELECTRICAL, IGNITION AND RADIO

SECTION	PAGE
M 7 Ignition System S3 Cars . . . . .	M 1 (S)
M 9 Lighting Equipment . . . . .	M 7 (S)
M 10 Instruments and Accessories . . . . .	M 13 (S)

## CHAPTER M

## ELECTRICAL, IGNITION AND RADIO

## SECTION M7—IGNITION SYSTEM—S3 CARS

**Distributor**

(Page M 28 in Workshop Manual)

Type	Lucas 20D8
Firing order	A1, B1, A4, B4, B2, A3, B3, A2
Timing	2° B.T.D.C.
Direction of rotation	Anti-clockwise
Contact gap	0.014 in. to 0.016 in. (0.356 mm. to 0.406 mm.)
Dwell angle	31° to 37° at 0.015 in. gap
Contact arm spring tension	18 oz. to 24 oz.
Condenser capacity	0.18 mfd. to 0.23 mfd.
Radio interference suppressor carbon resistor pick-up brush	5000 ohms to 6500 ohms approximately

**Coil**

(Page M 28 in Workshop Manual)

Type	Lucas HA12 negative earth
Insulation resistance to case	20 meg. at 500 v.
Primary winding resistance	4.25 ohms to 4.65 ohms at 75°F.
Secondary winding resistance	5500 ohms to 7100 ohms at 75°F.
Radio interference suppressor: Capacitor on 'SW' terminal	1 mfd.

**Sparking plugs**

9 : 1 compression ratio Make and type	Champion RN 8
8 : 1 compression ratio Make and type	Lodge CLNP Champion RN 13P Champion RN 8
Cars destined for Australia Make and type Gap	Champion UN 12 Y 0.025 in. (0.635 mm.)



**Distributor**

(Page M 28 in Workshop Manual)

**Description**

On S3 cars the distributor contains two sets of contacts which are wired in parallel and are so arranged that their actions overlap.

In this way, one set of contacts break the low tension circuit and initiate the high tension spark and after a brief dwell period the other set of contacts reconnect the low tension circuit.

The timing of the spark is controlled by a centrifugal governor, mounted on the distributor driving shaft beneath the contact breaker base plate. In addition to the centrifugal advance and retard mechanism, a vacuum timing control is provided, manifold depression being utilised to vary the timing in accordance with engine loadings.

An octane selector is mounted adjacent to the vacuum timing unit on the outside of the contact breaker housing. The octane selector consists of an eccentric pin working in a slot in the lower part of the distributor body, thus affording final manual adjustment of the ignition timing to suit low octane fuels.

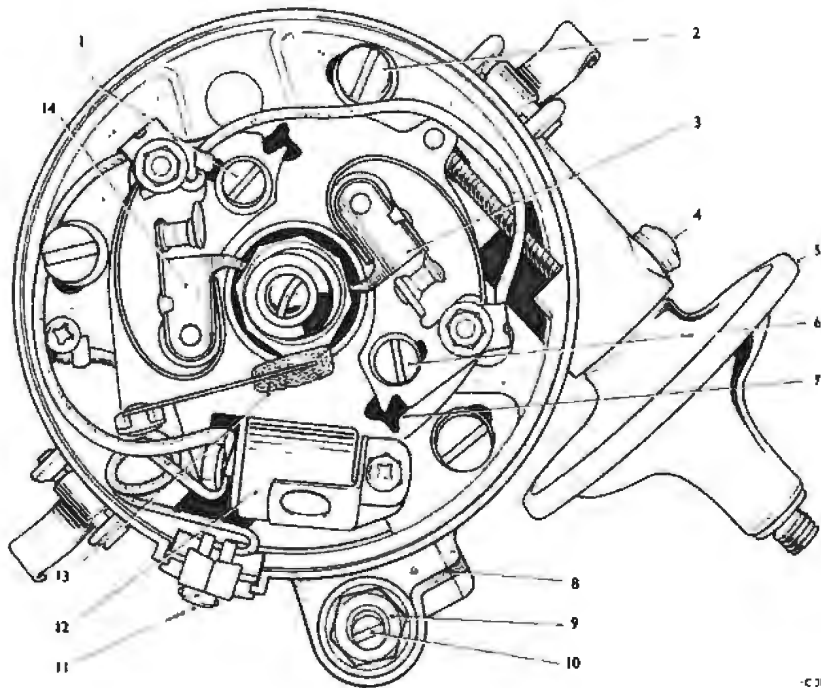

Fig. M1 (S) Internal view of distributor

- |   |   |                                       |
|---|---|---------------------------------------|
| 1 FIXED CONTACT PLATE<br>SECURING SCREWS    | 5 VACUUM TIMING CONTROL UNIT                  | 10 OCTANE SELECTOR ADJUSTING<br>SCREW |
| 2 CONTACT BREAKER HOUSING<br>SECURING SCREW | 6 FIXED CONTACT PLATE SECURING<br>SCREW       | 11 L. T. TERMINAL                     |
| 3 CONTACT BREAKER                           | 7 CONTACT BREAKER GAP<br>ADJUSTING SLOT       | 12 CONDENSER                          |
| 4 VACUUM UNIT SECURING SCREW                | 8 OCTANE SELECTOR SCALE                       | 13 CAM LUBRICATING PAD                |
|   | 9 OCTANE SELECTOR ADJUSTING<br>SCREW LOCK-NUT | 14 CONTACT BREAKER                    |

## Maintenance—Lubrication (Page M 28 in Workshop Manual) Every 6000 miles (10,000 kilometres)

### S3 cars only

Remove and clean the distributor cap, using a soft dry cloth; pay particular attention to the areas between the terminals. Check that the carbon brush is in its bore and that it moves freely.

Lubricate the centrifugal advance mechanism by injecting a few drops of clean engine oil through a convenient aperture in the contact breaker base plate.

Withdraw the rotor arm and inject a few drops of clean engine oil into the rotor arm spindle.

Lightly smear the faces of the cam with grease or clean engine oil.

Apply one drop of oil to each of the contact breaker pivots.

**Important** Do not allow oil or grease on or near the contacts when lubricating the distributor.

## Ignition timing Contact points—To clean and adjust (Page M 28 in Workshop Manual)

### S3 cars only

For identification of detail parts of the distributor, refer to Figure M1(S) of this Supplement.

#### Note:

To clean and accurately adjust the contact points, it may be considered more convenient to remove the distributor from the crankcase, therefore instructions for removing the distributor have been included in the following passages.

Remove the distributor cap, noting the position in which the rotor arm should be placed for the ignition of cylinder A1.

Press the button on the end of the starter motor relay to turn the crankshaft until the position of cylinder A1 is approached. This may be seen by the position of the rotor arm.

Remove the flywheel housing inspection cover and rotate the flywheel by hand to the correct ignition timing mark of 2° B.T.D.C.

The flywheel should only be turned in the normal direction of rotation (anti-clockwise when viewed from rear of engine). If rotated otherwise an inaccurate timing setting may be obtained due to backlash in the gears.

To remove the distributor from the crankcase, disconnect the low tension lead from the terminal on the distributor casing, then unscrew the two setscrews securing the distributor to the crankcase.

If the contact points require cleaning or refacing they should be removed from the distributor as follows.

Remove the nuts from the posts to which the contact breaker springs are anchored.

Remove the insulating pieces and electrical connections.

The contact breaker levers can then be lifted off the pivot posts.

Remove the screws (1 and 6 see Fig. M1 (S) of this Supplement) which secure the fixed contact points and withdraw the fixed contact points from the distributor.

Examine the contact points for pitting and piling. They should be cleaned as necessary with a fine carborundum stone, taking care to keep the contact faces as square as possible. If the points are seriously corroded they should be renewed.

To fit the contact points reverse the procedure for removal, taking care to align the points so that they make full face contact.

To adjust the points slacken the two screws (1 and 6) shown in Figure M1(S) of this Supplement, which secure the fixed contact points, then using a screwdriver in the contact breaker gap adjusting slot (7), set the gaps to between 0.014 in. (0.256 mm.) and 0.016 in. (0.406 mm.).

Tighten the two locking screws.

**Note** Should the crankshaft be rotated inadvertently while the distributor is removed from the engine, the correct position for ignition timing of A1 cylinder may be obtained as follows.

Remove the 'A' bank rocker cover which is on the right-hand side of the engine when viewed from the driver's seat. Rotate the crankshaft until the A1 inlet valve (the first valve at the front of the engine) has opened and just closed.

Rotate the crankshaft by hand in its normal direction of rotation until the flywheel is at 2° B.T.D.C.

Refit the 'A' bank rocker cover.

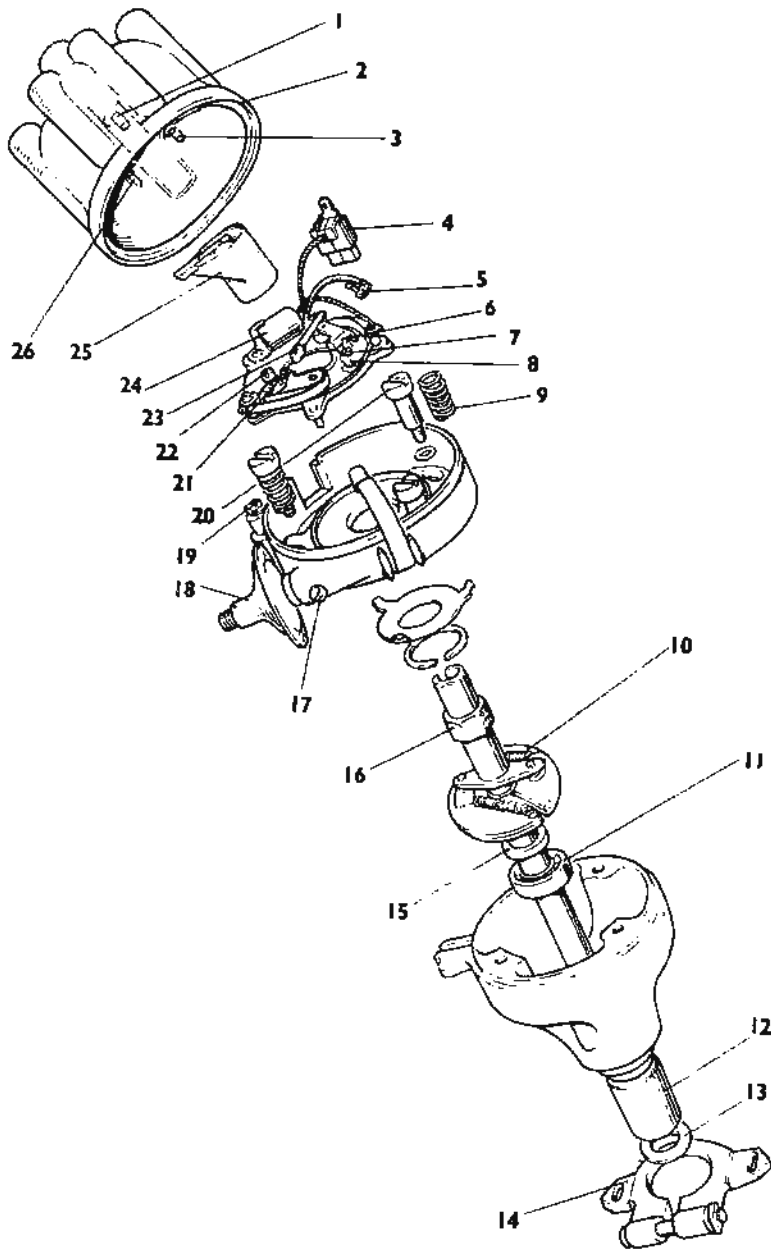

**Fig. M2 (S) Exploded view of distributor**

- |                                |                                       |                                    |
|--------------------------------|---------------------------------------|------------------------------------|
| 1 CARBON BRUSH                 | 10 CENTRIFUGAL TIMING CONTROL         | 19 OCTANE SELECTOR ADJUSTING SCREW |
| 2 DISTRIBUTOR CAP              | 11 BEARING                            | 20 SCREW C.B. HOUSING              |
| 3 H.T. ELECTRODE               | 12 DISTRIBUTOR BODY SPIGOT            | 21 CONTACTS                        |
| 4 L.T. TERMINAL                | 13 THRUST WASHER                      | 22 FIXED CONTACT SECURING SCREW    |
| 5 C.B. EARTH LEAD              | 14 SECURING PLATE                     | 23 CAM LUBRICATING PAD             |
| 6 CONTACTS                     | 15 DISTANCE COLLAR                    | 24 CONDENSER                       |
| 7 FIXED CONTACT SECURING SCREW | 16 CAM                                | 25 ROTOR                           |
| 8 C.B. GAP ADJUSTING SLOT      | 17 VACUUM TIMING CONTROL FIXING SCREW | 26 H.T. ELECTRODE                  |
| 9 SPRING                       | 18 VACUUM TIMING CONTROL UNIT         |                                    |

### Ignition timing—To adjust (Page M 31 in Workshop Manual)

#### S3 cars only

Time the ignition with the octane selector in the fully advanced position, this should be carried out as follows.

Release the lock-nut (9) shown in Figure M1(S) of this Supplement and set the octane selector (8) to the 'A' mark on the scale before carrying out the ignition timing.

Turn the distributor spindle until the rotor arm is in line with No. A1 cylinder ignition position.

Fit the distributor and secure the pedestal to the crankcase with two setscrews as shown in Figure M3(S) of this Supplement.

Release the distributor clamping screw, then rotate the distributor body until the set of contacts (14) shown in Figure M1(S) of this Supplement, opposite the vacuum advance unit, are just breaking.

During this operation hold the top of the rotor in the fully retarded position to take up any backlash in the centrifugal advance mechanism. Clockwise rotation of the distributor body will advance the timing, and anti-clockwise rotation will retard the timing.

The most suitable method of checking when the contact points are just breaking is with an ignition timing lamp.

Tighten the distributor clamping screw to lock the body in position.

Rotate the crankshaft two full turns and with the aid of an ignition timing lamp, recheck to ensure that the contact points are just breaking when the rotor arm is in line with No. A1 firing position and the flywheel is at 2° B.T.D.C.

### Distributor overhaul (Page M 31 in Workshop Manual)

For identification of the distributor components refer to Figure M2(S) of this Supplement.

Remove the distributor from the crankcase and remove the rotor arm and the contact breaker points. see 'Contact points—To clean and adjust' in this Supplement.

The distributor should then be dismantled as follows.

Unscrew and remove the condenser securing screw; withdraw the condenser.

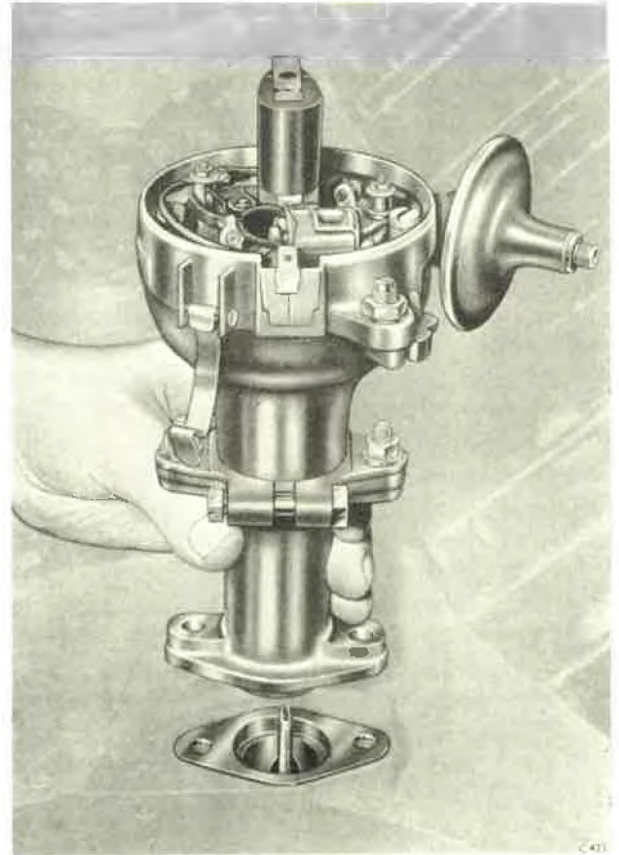

Fig. M3 (S) Method of fitting distributor

Remove the three spring-loaded screws (20) shown in Figure M2(S) of this Supplement; the upper portion of the distributor can then be withdrawn exposing the centrifugal advance mechanism.

Remove the circlip which retains the star washer on the underside of the contact breaker housing.

Lift the contact breaker base plate out of the contact breaker housing.

Unscrew the fixing screw (17) shown in Figure M2(S) of this Supplement and remove the vacuum diaphragm unit.

Remove the cam spindle screw and withdraw the cam assembly.

Lift the weights, springs and toggles off the action plate. To ensure correct re-assembly take care to **note the position** in which the parts are fitted in relation to each other.

Remove the tapered retaining pin which secures the driving sleeve to the shaft.

Remove the driving sleeve from the shaft and lift off the thrust washer.

Press the driving shaft out of the distributor body, taking care not to lose the distance piece located beneath the centrifugal timing control mounting plate.

Inspect the ball bearing at the top of the distributor body shaft housing. If excessive wear or roughness is apparent, the bearing should be withdrawn using a claw type extractor. Before fitting a new bearing, renew the neoprene oil seal located immediately below the bearing.

To facilitate fitting of the upper ball bearing, heat the distributor body to a temperature of 110°C. to 120°C.

Inspect the shaft for wear and parallelism; if excessively worn the shaft should be renewed.

If a new shaft is fitted, or if the shaft is only slightly worn a new bush should be fitted at the bottom of the distributor body. After fitting the bush ream it to size.

Assemble the distributor, reversing the procedure for dismantling, noting the following points.

Fit the distance collar to the shaft before fitting the shaft into the distributor body.

Ensure that the vacuum advance peg engages correctly with the vacuum unit spring link.

If facilities permit, it is advisable to check the automatic advance mechanism to ensure that the performance curves lie within the prescribed limits. The advance curves are shown in Figure M4(S) of this Supplement.

### Ignition coil (Page M 32 in Workshop Manual)

#### For S3 cars the first paragraph to read

The ignition coil fitted to S3 cars is of Lucas manufacture and is of negative earth polarity. The terminals are marked 'S.W.' (switch wire) and 'C.B.' (contact breaker).

### Sparking plugs (Page M 32 in Workshop Manual)

#### S3 cars only

The recommended sparking plugs are as follows

9 : 1 compression ratio	Champion RN 8
8 : 1 compression ratio	Lodge CLNP
	Champion RN 13P
	Champion RN 8

Cars desined for Australia Champion UN 12Y

Lodge CLNP and Champion RN 13P are platinum pointed plugs.

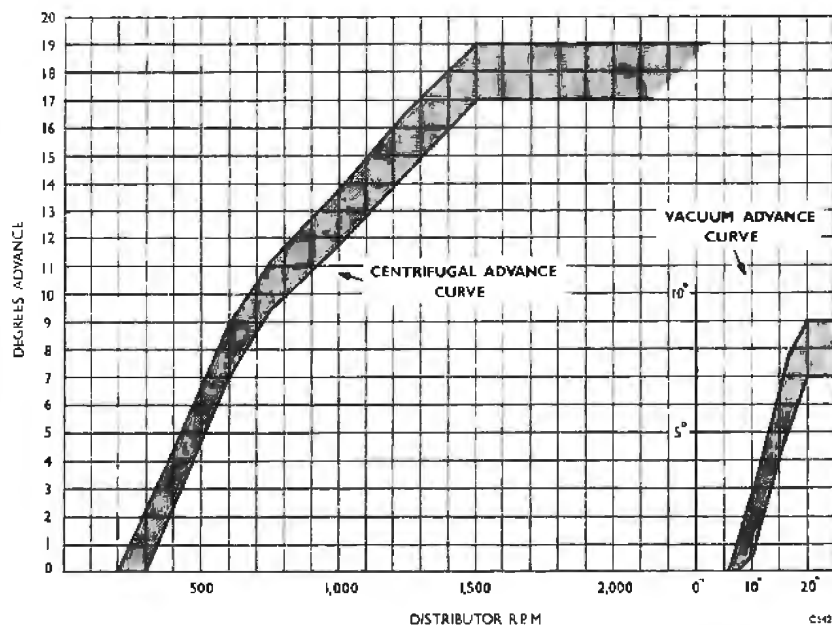

Fig. M4 (S) Ignition advance curves S3 cars

**Maintenance**

(Page M 32 in Workshop Manual)

**S3 cars only**

Every 6000 miles (10,000 kilometres) the plugs should be removed and cleaned. Before refitting the plugs, set the gaps by feeler gauge to 0.025 in. (0.635 mm.).

If Champion RN.8 sparking plugs are fitted, it is recommended that they be serviced using a standard sparking plug servicing and sand blasting machine.

If either Lodge CLNP or Champion RN.13P platinum pointed sparking plugs are fitted, they should be serviced by brushing off the carbon and inspecting the points.

Every 12,000 miles (20,000 kilometres) the plugs should be renewed to maintain satisfactory performance.

The remaining information in this Section which applies to S2 cars is also applicable to S3 cars.

**SECTION M9—LIGHTING EQUIPMENT****Headlamps**

(Page M 34 in Workshop Manual)

**S3 cars only**

The headlamps are controlled by two switches, the master switch on the fascia and a foot operated switch for beam selection. A small red warning lamp mounted in the speedometer is illuminated whenever the headlamps are on 'main beam'.

Four headlamps are fitted which are of the sealed beam type. The 'all glass' sealed beam units which are fitted to the majority of cars are in effect large gas filled bulbs having internal aluminised glass reflectors fused to the front lens; the filaments are accurately focused and sealed in the reflector.

Alternative lamp units are fitted to cars intended for countries where special lighting requirements exist. These units consist of a metal reflector and front glass sealed together and contain either a soldered in bulb or a detachable bulb.

The components of the 'all glass' sealed beam unit and the metal backed lamp unit with a soldered in bulb cannot be separated; failure of a filament necessitates the renewal of the complete unit.

In the case of the metal backed lamp unit which contains a bulb, failure of a filament necessitates the renewal of the bulb.

The two inner lamps each contain a single filament placed at the focal point of the reflector to provide long range illumination for main beam driving. The two outer lamps each contain two filaments, one fitted

at the focal point to provide the dipped beam, and the other displaced from the focal point to provide short range flood illumination for use in conjunction with the main beam.

For main beam driving all four lamps are switched on, the two inner lamps providing controlled long range illumination, whilst the out of focus filament in each outer lamp provides the short range flood illumination necessary to light the nearer section of the road. For dipped beam driving the filaments which are placed at the focal point of the outer two lamps are switched on, and provide illumination at intermediate range; when dipped beam is selected the four main beam filaments are switched off.

This arrangement of four separate lamps, enables the filaments for both the main and dipped beams to be accurately focused as required, to give the improved light distribution and greater accuracy of beam setting.

**Headlamp bulb—To renew**  
(Page M 35 in Workshop Manual)**For S3 cars read****Sealed beam unit—To renew**

To gain access to the lamp units, remove the headlamp fairing as follows.

Remove the two retaining screws and pull the top of the headlamp fairing out of the recess into which it is fitted.

Lift the fairing off the locating peg in the bottom of the headlamp recess.

Remove the lamp units as follows.

Slacken the three setscrews securing the headlamp bezel sufficiently to allow the bezel to be rotated; rotate the bezel so that the screw heads can pass through the enlarged end of the slots. Remove the bezel taking care that the sealed beam unit does not fall.

Withdraw the sealed beam unit and detach the connecting plug from the terminal at the rear of the unit.

The replacement unit should then be fitted by reversing the procedure described above, noting the following points.

Before refitting the headlamp fairing, the large rubber ring which fits around the lamp unit retaining bezel should be drawn forward slightly, thus effecting a pleasing appearance when the fairing is fitted.

To ensure that the lamps are correctly paired, lamp units for the inner two lamps have '1' or '1A' inscribed on the lens; these are single filament units. Similarly, lamp units for the outer two lamps have '2' or '2A' or 'European' inscribed on the lens and each contain two filaments.

When a replacement unit has been fitted, no appreciable change should be apparent in the alignment of the headlamp beams. If the alignment is in doubt, the headlamp beams should be checked and if necessary reset.

### Main beam setting (Page M 35 in Workshop Manual)

For S3 cars read

### Alignment and setting

The headlamp beams should be checked, and if necessary reset if the headlamp units or the wings have been disturbed for any reason.

To obtain the best results with the four headlamp system it is recommended that the Lucas 'Lev-L-Lite' beam aimer is used.

### Headlamps—To adjust

Drive the car onto a flat surface and ensure that the tyres are inflated to the recommended pressures.

Rock the car to equalise the suspension.

Remove the two retaining screws from each fairing and withdraw the fairings from around the headlamps to expose the beam adjusting screws.

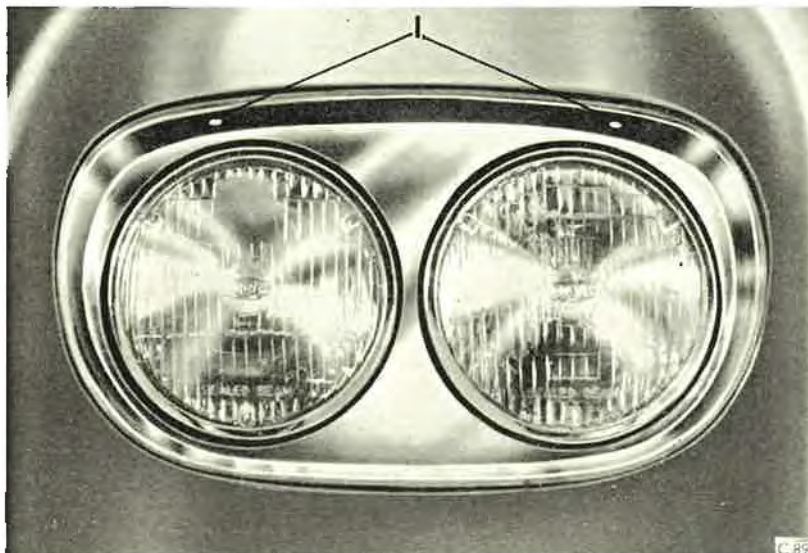

Fig. M5 (S) The headlamps  
1 SECURING SCREWS

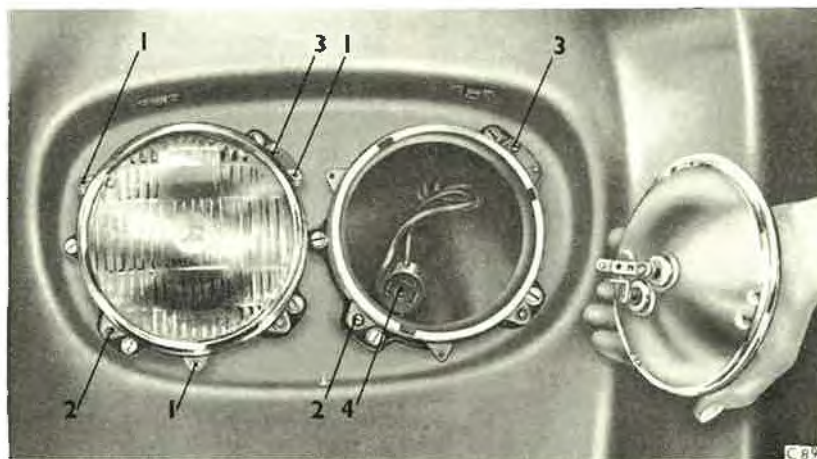

Fig. M6 (S) Access to the sealed beam units

- |                                   |                                 |
|-----------------------------------|---------------------------------|
| 1 SEALED BEAM UNIT SECURING SCREW | 3 VERTICAL BEAM ADJUSTING SCREW |
| 2 HORIZONTAL BEAM ADJUSTING SCREW | 4 CONNECTING PLUG               |

Clean the headlamp lens with a damp cloth.

Fit the Lucas 'Lev-L-Lite' beam aimers to each outer headlamp as follows.

The sight openings of the beam aimers must be facing the centre of the car. Place each beam aimer on the headlamp lens making sure that the three aiming pads of the lens engage the smooth inner ring of the aimer. Secure the aimer to the lamp by pushing forward the sliding handle situated underneath the beam aimer, until the vacuum cup engages the headlamp lens. Draw back the handle until the spring catch is engaged.

Set the pointer of the scale marked RIGHT—LEFT to ZERO, by means of the knob provided, then set the pointer of the scale marked UP—DOWN to one division down, by means of the knob provided; this must be done on each aimer.

Place the transit target on the floor by one of the rear wheels then place the transit on the floor by the front wheel on the same side. Turn the transit until the target is visible through the viewer.

Adjust the screw on the rear end of the transit until the split image of the target is aligned, then turn the knob situated on the left-hand side of the transit, until the bubble of the spirit level on top of the transit is central.

Note the reading on the dial of the transit, then obtain the same plus or minus reading on the dial situated in the end of the beam aimer, on that side of the car, by rotating the floor level compensator screw using a screwdriver.

Place the transit target on the floor by the rear wheel on the other side of the car and carry out the same procedure.

To check the horizontal aim, look through the viewer port on top of each beam aimer. If the images are aligned the horizontal setting is correct. If the images are not aligned adjustments should be made as follows.

Slacken the lock-nut on each of the horizontal adjusting screws, shown in Figure M6(S), then adjust the screws until the images are aligned. The final adjustments should always be made by turning the screw clockwise to eliminate backlash.

When the adjustment is correct, tighten the lock-nut.

To check the vertical aim, note the position of the bubble in the spirit level situated on the top of each beam aimer. If it is central then the vertical aim is correct, if it is not central adjustment should be made as follows.

Slacken the lock-nut on each of the vertical adjusting screws, shown in Figure M6(S), then adjust the screw



until the bubble in each spirit level is central. The final adjustment should always be made by turning the screw clockwise to eliminate backlash.

When the adjustment is correct, tighten the lock-nuts.

To remove the beam aimer, hold the aimer, release the spring catch, then push the sliding handle toward the headlamp.

To adjust the inner headlamps it is not necessary to again use the transit target and transit, but the setting of the floor compensator dial in the end of the beam aimers should not be altered.

The adjustment for the inner headlamps is similar to that described for the adjustment of the outer headlamps, the only difference being that both dials on top of the beam aimers must be set at ZERO.

When all the headlamps have been adjusted correctly refit the headlamp finishers making sure that the finishers do not foul the lamp bezels.

Before moving the car after the headlamp finishers have been fitted, the headlamps should again be checked with the 'Lev-L-Lite' beam aimers to make sure that the setting has not been upset.

In the event of a Lucas 'Lev-L-Lite' beam aimer not being available the headlamps may be adjusted by a visual setting using either of the following methods of alignment.

1 By employing a matt white painted movable screen marked out as shown in Figure M7(S) provided with an adjustable horizontal tape and aiming block and cords also shown in Figure M7(S).

The screen should be used on a flat floor which is approximately 40 ft. in length.

2 By employing a flat wall surface, preferably with a light coloured matt finish, marked out as in Figure M8(S) adjacent to a flat floor which is approximately 40 ft. in length and marked out as in Figure M8(S). An adjustable horizontal tape should also be provided.

**Method 1**

To prepare for checking the headlamp beam setting, drive the car onto the flat surface, then ensure that the tyres are inflated to the recommended pressures.

Remove the rear wheel discs.

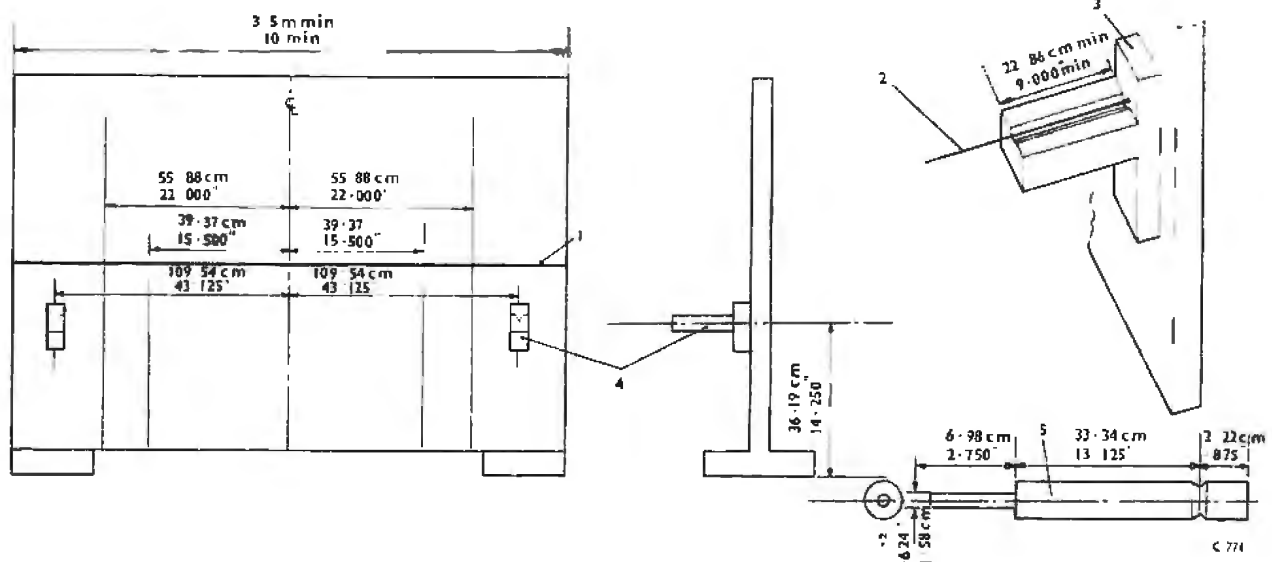

**Fig. M7 (S) Headlamp adjusting screen and accessories**

1 ADJUSTABLE HORIZONTAL TAPE  
2 CORD

3 AIMING BLOCK

4 POSITION OF AIMING BLOCKS  
5 CORD ANCHORAGE PEG

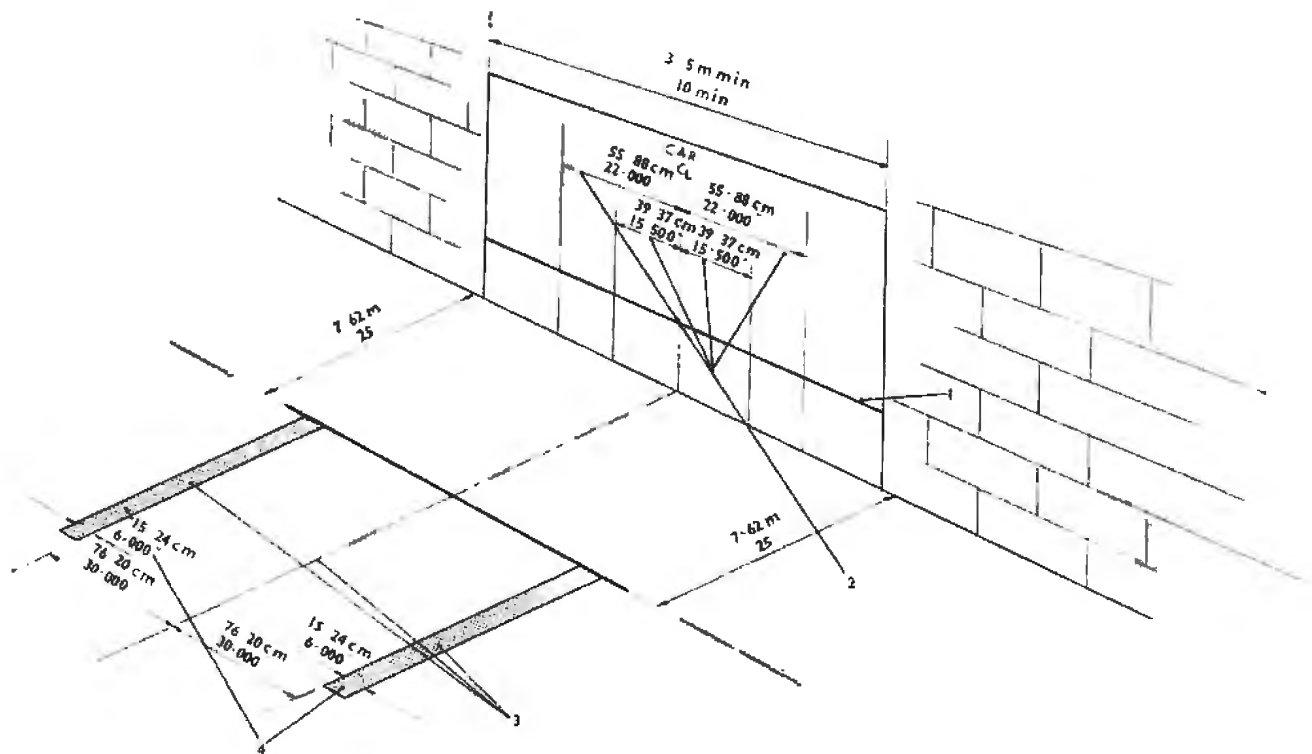

Fig. M8 (S) Wall and floor marked for headlamp adjustment

- |                                    |                                   |
|------------------------------------|-----------------------------------|
| 1 ADJUSTABLE HORIZONTAL TAPE       | 3 MEASUREMENTS OF REAR WHEELTRACK |
| 2 MEASUREMENTS OF HEADLAMP CENTRES | 4 WHEELTRACKS                     |

Remove the two retaining screws from each fairing and withdraw the fairings from around the headlamps to expose the beam adjusting screws.

Clean the headlamp lens with a damp cloth.

Rock the car to equalise the suspension.

Push the cord anchorage pegs into the holes in the rear axle shafts, then move the screen away from the car until the cords are taut. Move the screen sideways until the cords line up with the grooves in the aiming blocks.

### Method 2

To prepare for checking the headlamp beam setting, drive the car onto the flat surface with the front and rear wheels in alignment with the marks on the floor and the headlamps 25 ft. from the wall.

Because of the difference in front and rear wheel tracks, the front wheel should be  $\frac{1}{4}$  in. further inboard than the rear wheels. Check to ensure that the tyres

are inflated to the recommended pressures. Remove the two retaining screws from each fairing and withdraw the fairings from around the headlamps to expose the headlamp adjusting screws.

Clean the headlamp lens with a damp cloth.

Rock the car to equalise the suspension.

Whichever of the previous methods is employed for alignment, the aiming and adjustment of the headlamps is identical.

### Headlamp aiming

Measure the height to the centre of the headlamps from the ground and adjust the horizontal tape on the screen or wall to this height.

The lamps should be aimed in pairs, i.e. the two outer lamps for the meeting beam, and the two inner lamps for the main beam.

The outer pair of lamps must be covered whilst aiming the main beam.

**Main beam**

**Vertical aim** The centre of the high intensity zone should be on the horizontal centre line, which represents the height of the lamp centres from the floor on which the car is standing.

**Lateral aim** The centre of the high intensity zone should be on the vertical line straight ahead of the lamp centre.

**Meeting beam**

**Vertical aim** The top edge of the high intensity zone should be on the horizontal centre line, or not more than 1 in. below the horizontal centre line.

**Lateral aim** The right-hand edge of the high intensity zone should be 2 in. to the left of the vertical centre line, straight ahead of the lamp centre.

These aiming instructions are for right-hand drive cars. On left-hand drive cars the lateral aim of the meeting beam should be 2 in. to the right of the vertical centre line, straight ahead of the lamp centre.

If these settings are found to be incorrect the headlamps should be adjusted by the same method employed when using the Lucas 'Lev-L-Lite' beam aimer.

**Side lamps**

(Page M 36 in Workshop Manual)

**Side and flasher lamps**

On S3 cars each side and front indicator lamp is incorporated in a single lamp. The two bulbs are screened from one another but are placed behind a common lens. The flasher lamp bulb occupies the upper part of the lamp and the side lamp bulb the lower half.

To renew a bulb, unscrew the two lens retaining screws then withdraw the lens and rim; remove the bulb from the bulb holder. The bulbs are of standard bayonet fitting.

**Fog lamps**

(Page M 36 in Workshop Manual)

On S3 cars twin fog lamps are fitted and each contain a single filament pre-focus bulb.

To renew a bulb, unscrew the lens retaining screw and lift out the complete lamp unit. Release the bakelite contact holder by turning it in the direction of the arrow, then remove the bulb.

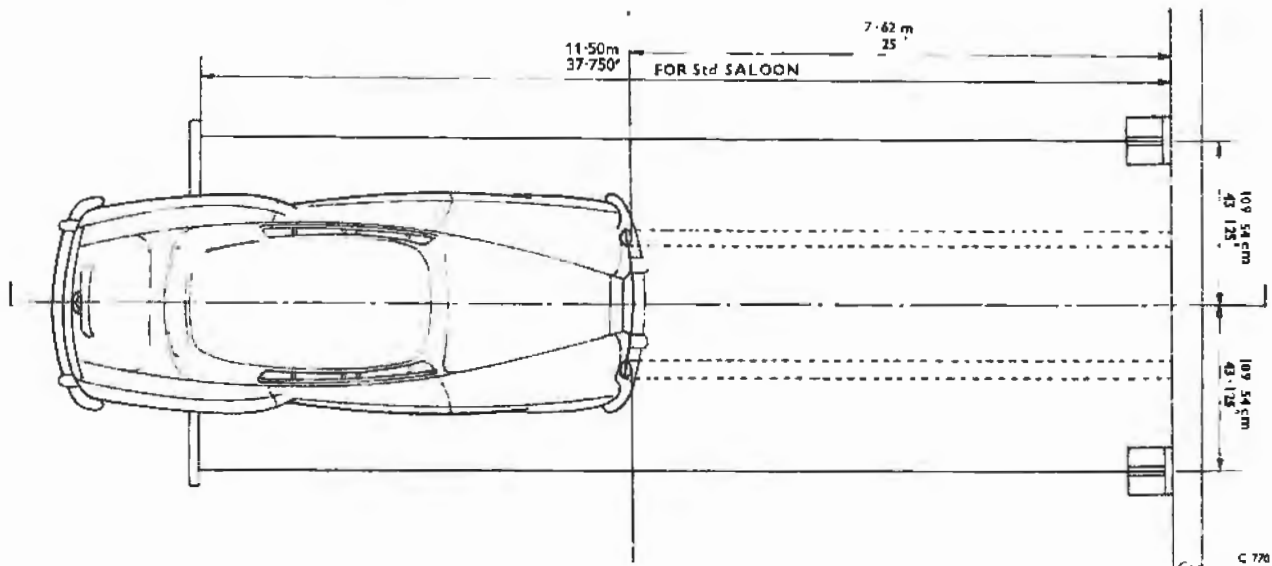

**Fig. M9 (S) Car in position for headlamp aiming**

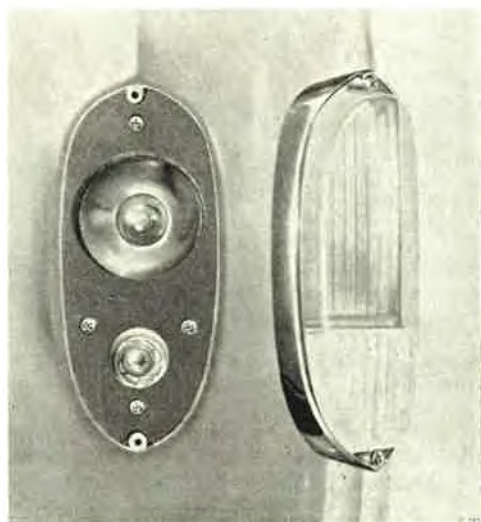

Fig. M10 (S) Access to the side/flasher lamp bulbs

### Hand brake warning lamp

On S3 cars a warning lamp is fitted to the fascia to remind the driver that the hand brake is applied. The lamp operates whenever the hand brake is applied and the ignition switched on.

Access to the bulb is gained behind the fascia; withdraw the lamp unit and remove the bulb. The bulbs are of standard screw-in fitting.

The remaining information in this Section which applies to S2 cars is also applicable to S3 cars.

## SECTION M10—INSTRUMENTS AND ACCESSORIES

### Direction indicators

(Page M 44 in Workshop Manual)

On S3 cars, the direction indicator switch mounted on the steering column is designed to indicate a turn and to flash the headlamps simultaneously. The switch energises the headlamp main beam circuit only.

To indicate a turn to the right, move the control lever up and to indicate a turn to the left, move the control lever down. The switch is cancelled auto-

matically when the steering wheel is moved to the straight ahead position after a turn.

To flash the headlamps draw the control switch towards the steering wheel. It is not possible to flash the headlamps when main beams are already in use.

On cars destined for the U.S.A. the headlamp flashing connection is omitted.

The sixth paragraph in the Workshop Manual is not applicable to the S3 car.

**Direction indicators—  
Self-cancelling adjustment****S3 cars**

If the steering box or steering column have been removed and the position of the steering column, relative to the steering box, has been altered it will be necessary to adjust the 'knock-off' cam mounted on the steering column.

To obtain access to the 'knock-off' cam, withdraw the lower half of the gear control quadrant after removing the two Allen screws.

Set the steering in the straight ahead position, then adjust the 'knock-off' cam by slackening the Allen grub screw and moving the cam until it lies directly between the two direction indicator switch 'knock-off' levers.

Tighten the Allen grub screw, then refit the lower half of the gear control quadrant and secure with the two Allen screws.

The remaining information in this Section which applies to S2 cars is also applicable to S3 cars.

**Radio**

(Page M 45 in Workshop Manual)

On S3 cars, the radio receivers fitted as standard equipment are as follows.

Model No.	Type
Smiths 'Radiomobile' 620 T	Medium and long wave, suitable for the whole of Europe with the exception of Spain, Portugal and Italy.
Smiths 'Radiomobile' 622 T	Medium wave only, suitable for the U.S.A., Canada and Japan.
Smiths 'Radiomobile' 230 R	Medium and short wave, suitable for Africa, Asia, South America, West Indies, Italy, Spain and Portugal.
Pye TCR 2000/E	Suitable for Australia and New Zealand.

**Description****On S2 cars**

(Page M 45 in Workshop Manual)

**For S3 cars the first paragraph to read**

The radio receivers fitted, with the exception of the 230 R and Pye TCR 2000/E consist of all-transistor units utilising nine transistors and two germanium diodes, operating directly from the 12 volt battery supply. The circuit comprises tuned aerial and R.F. amplifier stages, frequency changer and one stage I.F. amplification, demodulator, and a direct-coupled A.F. pair. The direct coupled A.F. pair drives a push-pull emitter follower stage which in turn drives the push-pull stage. The output stage is transformer coupled to a twin speaker balance-control circuit. Continuously-variable tone control is provided in conjunction with negative feed-back from the output transformer to the driver stage input. The receiver and controls are shown in Figure M11(S) of this Supplement.

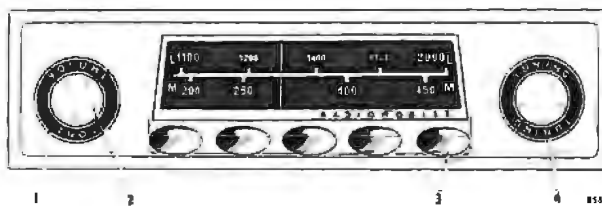

Fig. M11 (S) Radio controls 620T receiver

- |                                    |                         |
|------------------------------------|-------------------------|
| 1 TONE CONTROL                     | 3 TUNING BUTTONS        |
| 2 VOLUME CONTROL AND ON/OFF SWITCH | 4 MANUAL TUNING CONTROL |

**Receiver and amplifier—To remove**

(Page M 47 in Workshop Manual)

**For S3 cars the second paragraph to read**

Unscrew the six wood-screws, securing the receiver surround to the fascia panel; this surround need not be removed from the receiver. Withdraw the picnic table to its full extent to gain access to the receiver securing bolts. Unscrew the four 2 B.A. bolts positioned under the fascia, which secure the receiver brackets to their supports. Disconnect the battery feed to the receiver by unscrewing the fuse carrier and

removing the glass cartridge fuse. Remove the screw securing the earth cable to the receiver frame and withdraw the loudspeaker and aerial plugs. Carefully draw the receiver through the front of the fascia.

**Rear loudspeaker—To remove**  
(Page M 47 in Workshop Manual)

On S3 cars access to the rear loudspeaker is gained

through a removable panel in the roof trim of the luggage boot. Remove the screws securing the rear loudspeaker access panel and remove the panel. Disconnect two leads from the loudspeaker. Unscrew the wood screws securing the loudspeaker to its mounting board and remove the loudspeaker.

The remaining information in this Section which applies to S2 cars is also applicable to S3 cars.

# CHAPTER N

## STEERING

<b>SECTION</b>		<b>PAGE</b>
<b>N 1</b>	<b>Data and Description . . . . .</b>	<b>N1 (S)</b>
<b>N 2</b>	<b>Oil pump — Power-assisted Steering . . . . .</b>	<b>N3 (S)</b>
<b>N 3</b>	<b>Power Cylinder Hoses . . . . .</b>	<b>N9 (S)</b>
<b>N 7</b>	<b>Steering Column and Steering Box — S3 Cars . . . . .</b>	<b>N9 (S)</b>

## CHAPTER N

## STEERING

## SECTION N1 — DATA AND DESCRIPTION

**Data**

(Page N1 in Workshop Manual)

**S3 cars only**

Steering wheel diameter	17 in. (43.18 cm.)
Steering box gear ratio	18.7 : 1
Number of turns of steering wheel lock to lock	4½

**On S2 cars**

(Page N3 in Workshop Manual)

**For S3 cars the first paragraph to read**

The connecting shaft at the lower end of the steering tube enters a rubber coupling; the coupling transmits steering wheel movement to a gear mounted on two taper roller bearings on an eccentric shaft in the transfer gearbox. The function of the transfer gearbox is to offset the drive from the lower end of the steering column to the steering box which is positioned out-board of the chassis sidemember. The cast iron casing contains two helical gears mounted on 3.758 in. (94.45 mm.) centres and having a gear ratio of 1 : 1. Splines in the bore of the driven transfer gear locate on splines at the rear end of the cam tube which carries the steering cam.

**On S1 and S2 cars**

(Page N5 in Workshop Manual)

**For S3 cars the first paragraph to read**

The power assistance unit provides a variable proportion of assistance controlled by the effort required at the steering wheel. When maximum assistance is required for low speed manoeuvring, such as shunting or parking the car it is provided at full pump pressure automatically.

**For S3 cars the following five paragraphs should be read in place of the sixth and seventh.**

By axial movement of a spool valve in the housing

situated between the transfer box and the steering box; causing annular grooves in the valve to communicate with passages in the spool valve housing which direct oil to the appropriate side of the hydraulic ram. Movement of the spool valve is effected by the reaction of a normal steering cam against the roller when the steering wheel is turned. The spool valve is normally held in the central or no load position by a disc spring washer at each end of the spool valve housing. Any load applied at the steering wheel rim is sufficient to displace the spool valve from the central position, thus causing oil to be directed to the appropriate side of the hydraulic ram.

The pressure at which oil is delivered is dependent upon the resistance encountered at the ram. As the resistance on the ram increases, the pump rapidly builds up pressure in the system until it is delivering at the maximum controlled pressure of approximately 750 lb/sq.in.

Figure N1 (S) of this Supplement shows the oil circulating diagram when the steering is in straight ahead or no load position. The delivery pressure from the pump is approximately 80 lb/sq.in. The pressure in the steering box is approximately 60 lb/sq.in. and the pressure of the return flow to the reservoir is approximately 5 lb/sq.in.

Figure N2 (S) of this Supplement shows the condition when commencing a normal right-hand turn on the open road. The assistance is automatically regulated by the load applied at the steering wheel rim and the position of the spool valve in the valve housing.

Figure N3 (S) of this Supplement shows the condition when parking on left-hand lock under very heavy load conditions. The spool valve is fully opened and the oil pressure has built up to the maximum allowed by the pump relief valve.



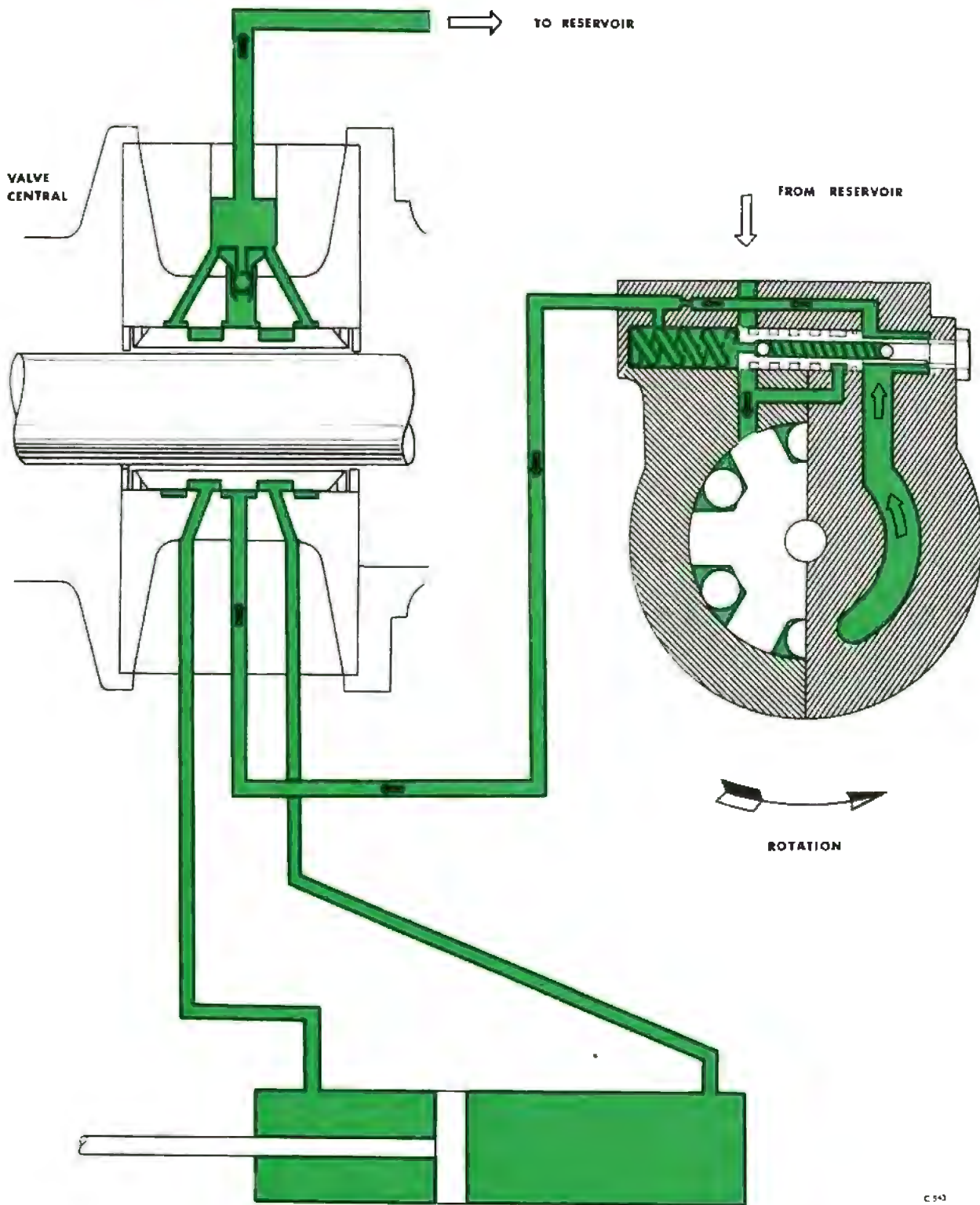

Fig. N1 (S) Circulation diagram—steering straight ahead conditions—no load

N2 (S)

**The flow control valve and pressure relief valve**

On S3 cars the flow control valve is situated in a bore alongside the pump discharge port; its function is to control the flow of oil leaving the pump.

On leaving the pump the oil has to pass through a metering hole situated in the outlet port. As the speed of the pump increases the volume of oil which has to pass through the metering hole also increases, causing a pressure build up on the end of the flow control

valve; this pressure forces the valve along the valve housing until it uncovers a by-pass port, which directs oil in excess of 1.4 gals. to 1.7 gals. (6.47 litres to 7.7 litres) per minute back to the inlet side of the pump.

When the pressure in the system exceeds approximately 750 lb/sq.in. (52.73 kg/sq.cm.) the relief valve inside the flow control valve is forced back, compressing its spring and uncovering a bore through which oil in excess of this pressure is returned to the inlet side of the pump.

**SECTION N2 — OIL PUMP — POWER ASSISTED STEERING****Description — S3 cars**

Basically the power assisted steering pump consists of a ring of rollers axially disposed around a rotor which operates within a cam ring. The rotor, rollers and cam ring are mounted inside a split pump body; the rotor is keyed to a shaft which is driven by the engine. As soon as the rotor begins to revolve, centrifugal force causes the rollers to move outward into contact with the cam; this action forms a working chamber between the cam ring and the rotor, the roller acting as a seal between the two. As the pump rotates this working chamber increases and decreases in volume relative to the position of the cam and rotor. During the phase when the volume is increasing, oil is drawn into the pump from the reservoir via the inlet port. Further rotation of the pump results in a decrease in the volume of the working chamber and consequent pressurising of the oil in the chamber; thus oil is forced under pressure out into the discharge port of the pump and on into the system.

After passing through the system, the oil returns to the reservoir through the main filter. For technical reasons it is necessary to position the filter in the return flow to the reservoir and any foreign matter must find its way through the system before being filtered. The circulation of oil is maintained at a constant flow by the flow control valve described in 'The flow control valve and pressure relief valve' of this Supplement.

**Servicing (Page N7 in Work-shop Manual)  
Oil level — To check****S3 cars only**

Every 6000 miles (10,000 Kms.), the oil level in the steering pump reservoir should be checked and if necessary topped-up with one of the recommended fluids until the level of the fluid is just above the top of the filter.

**Note** It is important that only clean oil should be used to top-up the steering pump reservoir.

**Filter element — To renew**

(Page N9 in Workshop Manual)

**For S3 cars the first paragraph to read**

The oil filter element must be changed every 24,000 miles (40,000 Kms.).

**Priming and filling the system**

(Page N9 in Workshop Manual)

**S3 cars only**

To ensure that the steering system operates smoothly and free from judder it is essential that all air is expelled from the system, it is therefore recommended that the following priming procedure is adhered to.

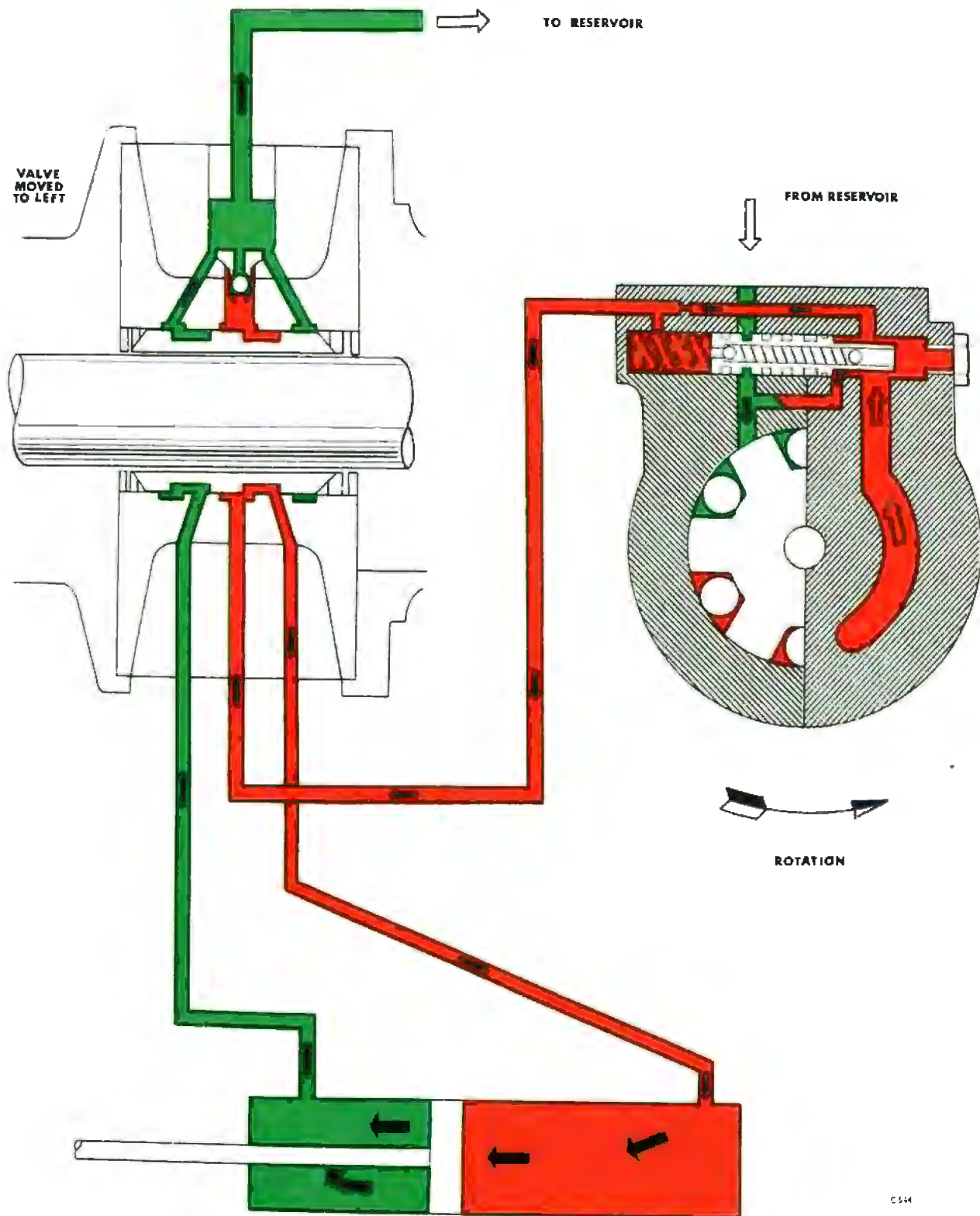

Fig. N2 (S) Circulation diagram—normal turning condition right-hand lock — light load

N4 (S)

Fill the steering pump reservoir until the fluid is just above the top of the filter.

Start the engine and allow it to idle.

Set the steering system so that the piston in the hydraulic ram is in its most forward position, i.e. on right-hand drive cars the steering should be set on full left-hand lock; on left-hand drive cars the steering should be set on full right-hand lock.

Remove the protective cap, fit a bleed tube to the hydraulic ram bleeder nipple and insert the free end of the tube into a clean glass jar.

Unscrew the bleeder nipple sufficiently to allow fluid to pass into the jar.

During the previous operations the level of the fluid in the steering pump reservoir should be constantly checked and topped-up to the correct level.

Continue bleeding until air bubbles no longer issue from the bleed tube.

Tighten the bleeder nipple, remove the bleed tube and refit the protective cap.

Finally return the steering wheel to the central position and recheck the level of the fluid in the steering pump reservoir.

On later S3 cars a bleeder nipple is fitted also in the top of the rocking shaft bearing housing.

To bleed from this nipple carry out the same procedure as employed when bleeding the hydraulic ram, but with the steering wheel in the straight ahead position.

### Oil pump — To test

To follow 'Oil pump — To remove'  
(Page N9 in Workshop Manual)

If facilities exist it is advisable to test the pump to ensure that it is delivering the correct pressure and flow.

### Test data

#### S3 cars only

Flow 1.4 gals. to 1.7 gals. (6.47 litres to 7.7 litres)  
per minute at 3000 (Pump) r.p.m.  
Pressure 700 lb/sq.in. to 750 lb/sq.in. at 900 (Pump)  
r.p.m.

If the steering pump is not delivering the correct pressure and flow, ensure that the flow control valve is not sticking. If the flow control valve is found to be operating satisfactorily, it will be necessary to dismantle and inspect the pump.

### Oil pump — To dismantle and inspect (Page N10 in Workshop Manual)

For S3 cars the third paragraph onwards to read

For identification of detail components refer to Figure N4 (S) of this Supplement.

Remove the reservoir cover; lift off the spring and filter retaining washer and withdraw the filter.

Screw a  $\frac{5}{16}$  in. UNF nut onto a  $\frac{5}{16}$  in. UNF setscrew; screw the setscrew into the centre pedestal, tighten the nut and remove the pedestal.

If the previous method is not successful, a pair of grips may be used to remove the pedestal.

Remove the filter support plate.

Remove the setscrew and the  $\frac{3}{4}$  in. UNF blanking plug, then withdraw the clamping plate (7). See Figure N4 (S) of this Supplement.

Lift off the reservoir body taking care not to misplace the rubber sealing rings and distance plate located beneath the body.

Withdraw the sleeve from the inlet port of the pump.

Remove the pump pulley, if necessary using a suitable extractor; take care not to misplace the Woodruff key.

Using an Allen key unscrew the six setscrews which secure the two halves of the pump body together.

Separate the pump from the cover and collect the sealing ring (14) shown in Figure N4 (S) of this Supplement.

Before removing the rotor, rollers and cam ring, **take note** of the direction in which the rotor is fitted.

Using a straight edge across the body of the pump, check with a feeler gauge, the end clearance of the rotor and rollers. This should be within the range 0.001 in. to 0.0018 in.

Remove the rotor, rollers and cam ring from the pump body, taking care not to misplace the rotor driving key from the shaft.

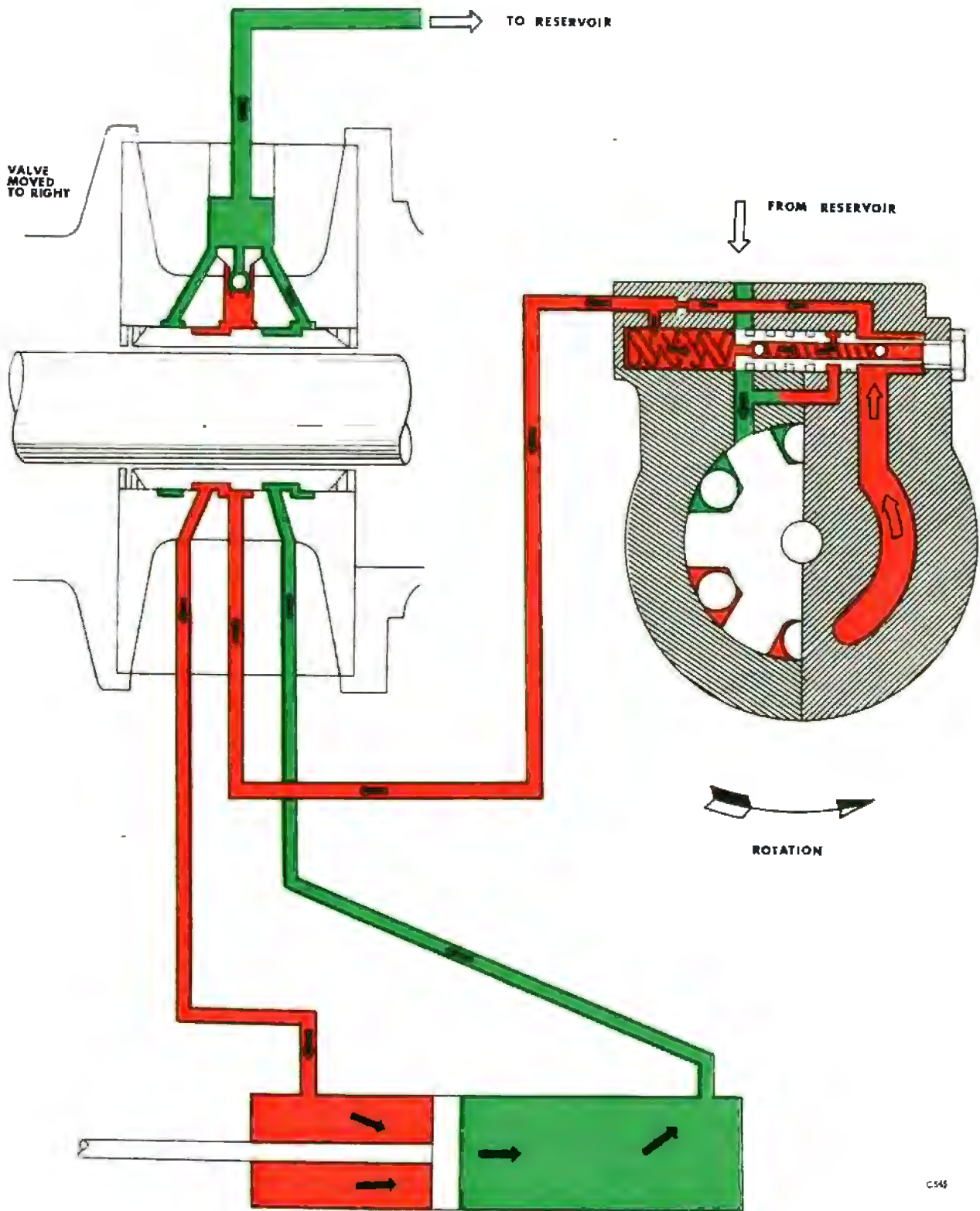

**Fig. N3 (S) Circulation diagram—parking condition — left-hand lock — very heavy load**

Unscrew the four countersunk headed screws and remove the bearing retaining plate.

Remove the shaft from the housing, then gently tap the oil seal out of the housing.

Inspect the bearing for wear or damage, if excessively worn the bearing should be removed from the shaft and a new one fitted.

Remove the flow control valve plug (30) (see Figure N4 (S) of this Supplement) from the side of the pump body and withdraw the combined flow control and relief valve, taking care not to misplace the flow control valve spring.

Inspect the pump body and cover, for wear or scoring by the rotor; if excessive wear or scoring has taken place and the end clearance of the rotor in the body exceeds 0.0018 in., the body and cover should be renewed and a new matched set of rotor, rollers and cam ring fitted.

### Oil pump — To assemble (Page N11 in Workshop Manual)

**For S3 cars the second paragraph onwards to read**

Coat the outside of the new oil seal with a thin layer of Wellseal, then after greasing the lip of the new seal, insert it into the pump body. Care should be taken not to damage the seal.

Insert the drive-shaft, at the same time turning it so as to minimise the risk of damage to the oil seal. Tap the bearing into the body, then using the four countersunk headed screws, fit the bearing retaining plate.

Fit the cam ring, ensuring that it is located correctly on the pin in the pump body.

Fit the key and slide the rotor on to the shaft. The rotor should be fitted so that when viewed from the rear of the pump, the leading edge of the rotor blades should face anti-clockwise.

Insert the six rollers into the spaces between the rotor blades. Fit new rubber sealing rings in the

annular groove formed on the end of the cam ring and in the recess formed in the flow control by-pass port. Fit the six Allen setscrews to secure the cover to the pump body. Whilst tightening the setscrews rotate the shaft to ensure that no binding takes place.

Fit the flow control valve spring and the combined flow control and relief valve into the pump body, ensuring that it moves freely in its bore.

Fit the flow control valve cap using a new 'O' ring.

Fit the reservoir to the pump body ensuring that new sealing rings are fitted to each side of the distance plate. Fit the sleeve into the inlet port of the pump, then using the  $\frac{3}{4}$  in. UNF blanking plug and the  $\frac{1}{8}$  in. UNF setscrews secure the reservoir firmly to the pump body.

Fit the filter support plate and the centre pedestal, then tighten the pedestal in a similar manner to that described for removal.

Fit the filter, filter retaining washer, spring and reservoir cap ensuring that the reservoir cap seal and the securing screw seal are in good condition.

### Fault diagnosis (Page N12 in Workshop Manual)

**For S3 cars the fourth paragraph to read**

The pump delivery pressure should be approximately 750 lb/sq.in. (52.73 kg/sq.cm.), with the engine idling and the wheels against the stops.

### Steering judder

**On S3 cars** a probable cause of steering judder is the presence of air in the system. This can be removed by priming the steering system as described on Page N3(S) in this Supplement; ensure that the correct fluid level is maintained in the reservoir.

The remaining information in this Section which applies to S2 cars is also applicable to S3 cars.

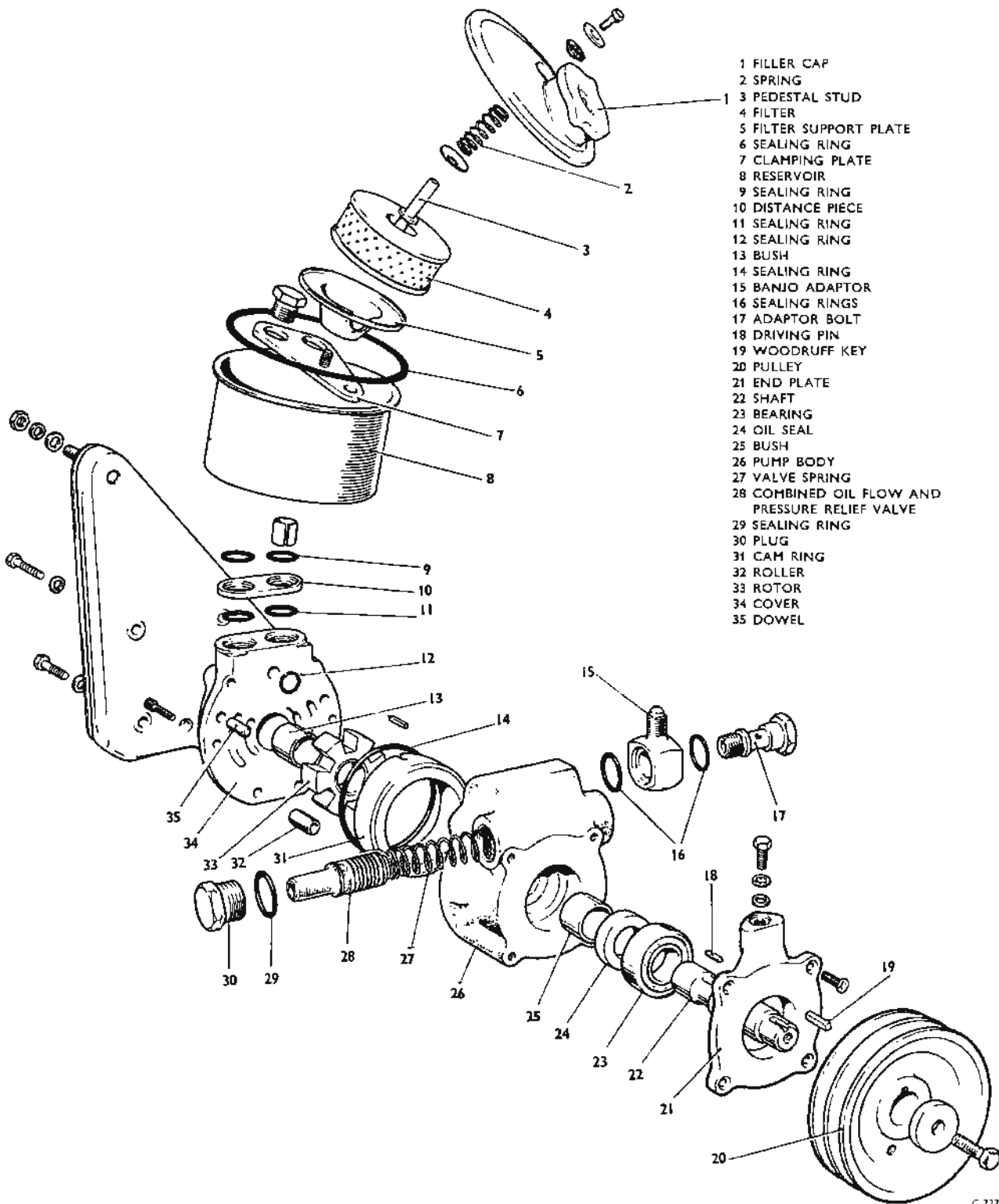

Fig. N4 (S) Exploded view of steering pump

C 737

## SECTION N3 — POWER CYLINDER AND HOSES

**Hoses****Right-hand drive — S2 cars**  
(Page N14 in Workshop Manual)**For S3 cars the second paragraph to read**

The delivery hose from the pump to the valve housing, sweeps down from the pump to a clip at the centre of the front pan; it then passes through a clip on the right-hand damper top. From this point it runs alongside the power cylinder rear hose and is connected to the higher of the two remaining ports. The return hose from the valve housing to the pump is connected to the remaining port in the valve housing, it then sweeps downwards from the valve housing through a clip on the steering box mounting arm; from the mounting arm the hose rises and passes over the front of the engine crankcase and is connected by a worm drive clip to the inlet pipe on the pump reservoir.

**Hoses****Left-hand drive — S2 cars**  
(Page N14 in Workshop Manual)**For S3 cars the first paragraph to read**

From the valve housing, the two power cylinder hoses sweep inwards and down to a clip on the inner surface of the chassis side member, then rise to a clip on the left-hand damper top and a clip at the lower corner of the valance before leading down behind the stabilizer bar to the power cylinder. The return hose from the valve housing sweeps in and down to the clip on the inner surface of the chassis side member, from where it rises to another clip on the engine crankcase. From the clip on the crankcase the hose sweeps underneath and behind the pump to connect to the inlet union.

## SECTION N7 — STEERING COLUMN AND STEERING BOX

**Servicing**

(Page N35 in Workshop Manual)

**For S3 cars the following two paragraphs should be read in place of the first**

Every 24,000 miles (40,000 Kms.) check the oil level in the transfer gearbox. Remove the filler plug and the oil level plug. The filler plug is positioned on top of the driven gear casing; the oil level plug is positioned at the front of the driving gear casing, adjacent to the eccentric adjuster. If necessary, the transfer gearbox should be topped-up with the approved oil to the oil level hole. Fit the filler and level plugs.

If when checking the oil level in the transfer gearbox, it is found that an excess of oil is present, this may be due to a fault in the oil seal situated in the transfer

gearbox adaptor plate which is positioned between the transfer gearbox and the steering box spool valve housing; in this case it will be necessary to renew the oil seal as described in 'Steering box oil seals — To renew' of this Supplement.

**Steering column and steering box — To remove****S3 cars**

If the steering column and steering box are required to be removed as separate assemblies, follow the procedure described in 'Steering column—To remove' and 'Steering box—To remove' (Page N36 in Workshop Manual).

It is possible to remove the steering column and steering box as a complete assembly as follows.

Disconnect the battery leads.



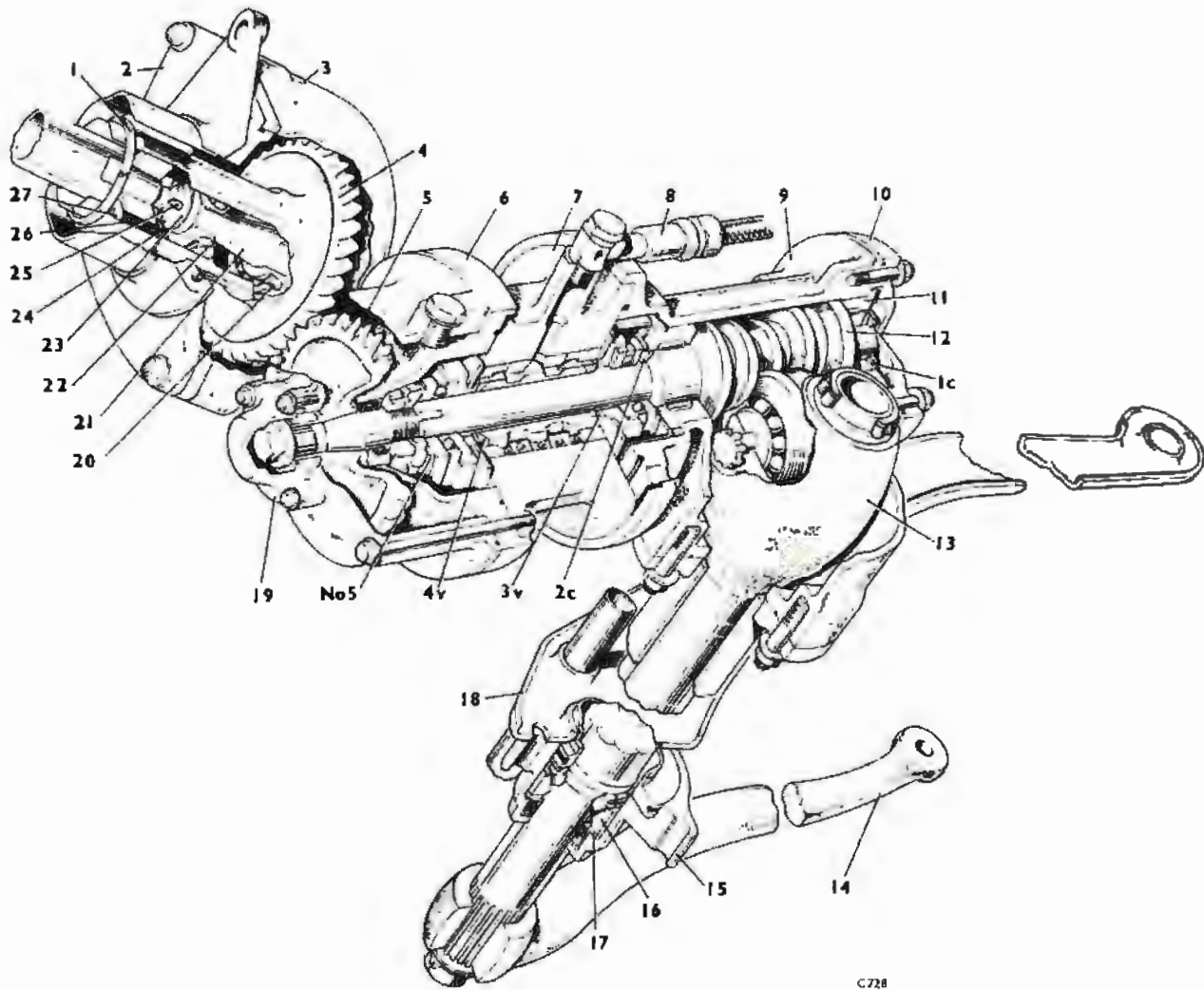

**Fig. N5 (S) Cut-away view of steering box**

- |                         |                     |                    |
|-------------------------|---------------------|--------------------|
| 1 SNAP RING             | 10 END COVER        | 19 BEARING HOUSING |
| 2 TOP COVER             | 11 OUTER RACE       | 20 BEARING         |
| 3 TRANSFER GEAR CASING  | 12 STEERING CAM     | 21 ECCENTRIC PIN   |
| 4 DRIVING GEAR          | 13 ROCKING SHAFT    | 22 BEARING         |
| 5 DRIVEN GEAR           | 14 PENDULUM LEVER   | 23 NUT             |
| 6 ADAPTOR VALVE HOUSING | 15 BEARING HOUSING  | 24 DISTANCE PIECE  |
| 7 SPOOL VALVE HOUSING   | 16 OUTER RACE       | 25 SPLIT PIN       |
| 8 ADAPTOR               | 17 ADJUSTING WASHER | 26 COUPLING        |
| 9 STEERING BOX          | 18 MOUNTING ARM     | 27 DISTANCE PIECE  |
- 
- |                                       |                                       |
|---------------------------------------|---------------------------------------|
| 1C LOWER CAM ADJUSTING WASHER         | 2C UPPER CAM ADJUSTING WASHER         |
| 3V LOWER SPOOL VALVE ADJUSTING WASHER | 4V UPPER SPOOL VALVE ADJUSTING WASHER |
- No. 5 SPOOL VALVE CROSS-LOAD ADJUSTING WASHER

Apply the hand brake and carefully position a jack under the front pan; ensure that the jack head cannot contact and so damage the power steering cylinder as it is raised. Jack up the front of the car and position supports under the stabilizer rod chassis mountings.

To gain access to the steering box; remove the front wheel and the valance plate panel from the driver's side of the car.

**On right-hand drive cars**, it is necessary also to remove the undersheet on the right-hand side of the car.

Remove the three screws retaining the horn push plate assembly to the steering wheel. Disconnect the horn wire snap connector and withdraw the assembly. Unlock and remove the steering wheel retaining nut and tab washer.

A scribed line or centre punch dot should be used to mark the wheel hub position in relation to the shaft for convenient assembly.

Refit the nut a few threads to prevent damage to the threaded end of the tube.

Using Special tool RH 593 in conjunction with the pressure pad RH 7271, withdraw the steering wheel; care should be taken not to trap the horn wire between the steering tube and extractor.

Remove the extractor and the retaining nut and lift off the steering wheel.

Remove the front seats and carpet, then remove the setscrews securing the insulating panel and gas seal plate to the bulkhead. Remove the brake fluid pipe clip attached to one of the setscrews securing the insulating panel.

Remove the foot brake pedal from the brake pedal lever and slide the insulator panel, together with the gas seal plate, along the column.

Disconnect the horn and earthing wires situated midway along the steering column.

Remove the two screws and withdraw the horn brush housing.

Disconnect the ride control and flasher indicator wires at the junction behind the fascia panel.

Disconnect the micro-switch wires.

Unscrew the pinch bolt and nut from the gear operating lever at the lower end of the control rod.

Remove the two screws which secure the ride control switch to the steering column.

Unscrew the two Allen screws securing the gear range quadrant to the steering column. Remove the quadrant and withdraw the control rod from the operating lever. Remove the control rod from the steering column, taking care not to misplace the locating key fitted at the lower end of the control rod.

Remove the micro-switches from the lower end of the steering column.

Remove the nut, lock-washer and plain washer securing the pendulum lever to the splined end of the rocking shaft. Mark the position of the pendulum lever in relation to the rocking shaft to assist in re-assembly, then withdraw the pendulum lever using extractor tool RH 321.

**On left-hand drive cars**, if difficulty is experienced in fitting the extractor tool owing to lack of space between the end of the rocking shaft and the exhaust pipe, the pendulum lever should be withdrawn when the steering box mountings have been removed.

Disconnect the oil pipes from the spool valve housing and mask the ends to prevent oil leakage and the ingress of dirt.

Unscrew the two Allen screws and remove the steering column clamp from the bracket on the fascia.

Remove the nut, bolt and washers securing the steering box mounting arm to the bracket on the chassis frame.

Support the steering box and remove the four setscrews, washers and mounting brackets securing the mounting tube in position on the chassis frame.

At this point a second operator is required to assist in the removal of the steering box and column from the chassis.

Support the steering box and remove the insulating panel and gas seal plate from the steering column. To facilitate this, wrap the steering column with masking tape, particularly around the tube which normally contains the wires for the ride control and direction indicator switches. A light coating of a rubber lubricant will also assist the removal of the panel and gas seal plate.

Carefully remove the steering column and steering box, taking care not to damage or mark the enamelled outer tube of the column.

## **Steering column and box — To dismantle**

### **S3 cars only**

Unscrew and remove the four setscrews and washers securing the transfer gearbox to the valve housing adaptor. Place a suitable container beneath the transfer gearbox to collect the oil which will drain from it.

The steering column may then be dismantled following the procedure described in 'Steering Column — To dismantle' (Page N36 in Workshop Manual) noting that the first six paragraphs are not applicable if the steering column and steering box have been removed as a complete assembly.

## **Steering box — To dismantle** (Page N37 in Workshop Manual)

### **S3 cars only**

It should only be necessary to dismantle the steering box for the renewal of the transfer gears, the cam tube oil seal and the rocking shaft oil seal.

No attempt should be made to remove the valve housing assembly, the steering cam tube assembly or the rocking shaft assembly from the steering box.

Should faults or damage occur in these assemblies the complete steering box should be returned to

CREWE SERVICE DEPARTMENT  
ROLLS-ROYCE LIMITED  
Pym's Lane, Crewe  
Cheshire England.

To remove the driven transfer gear from the steering cam tube, remove the setscrew and washer securing the gear whilst holding the gear by means of the special tool RH 7235. Mark the position of the driven gear to the cam tube, then withdraw the gear using extractor RH 7226.

Remove the transfer gearbox adaptor plate and tap out the oil seal.

## **Steering box oil seals — To renew**

### **S3 cars only**

To remove the steering cam tube oil seal carry out the procedure as described in 'Steering box — To dismantle' in this Supplement.

Smear the new oil seal outer casing with a small amount of Wellseal then fit the new oil seal into the adaptor plate.

Fit the adaptor plate to the steering box as described in 'Steering box — To assemble' of this Supplement.

To renew the rocking shaft oil seal, remove the lower bearing housing from the steering box, taking note of the position of the pointer in relation to the scale engraved on the steering box mounting arm.

Remove the taper roller bearing and the adjusting washer, then tap out the oil seal.

Smear the new oil seal outer casing with a small amount of Wellseal then fit the new oil seal into the bearing housing; replace the adjusting washer and refit the taper roller bearing. Fit a new 'O' ring into the groove in the steering box mounting arm. Mask the splines of the rocking shaft to avoid damaging the oil seal. Refit the bearing housing to the steering box ensuring that the position of the pointer is in its original position.

## **Steering box — To assemble** (Page N39 in Workshop Manual)

### **S3 cars only**

Having renewed the steering cam tube oil seal, fit a new 'O' ring into the transfer gearbox adaptor plate, then fit the adaptor plate to the steering box.

Fit the driven transfer gear onto the cam tube, ensuring that the correlation marks are in alignment.

Fit the setscrew and washer, then tighten the setscrew by holding the driven gear by means of the special tool RH 7235.

**Note** The transfer gears are supplied in pairs and must not be interchanged with other gears; there is also a correlation mark on each gear to provide the best meshing on assembly.

Fit a new 'O' ring into the transfer gear casing, then fit the casing to the steering box.

Fit a new 'O' ring inside the transfer gear casing, then fit the transfer drive gear assembly. Ensure that the correlation marks on the teeth of the transfer gears are aligned.

Coat the transfer gear teeth with Retinax 'A' grease and adjust the gear mesh to obtain zero backlash by rotating the eccentric pin. The lock-nut must be tightened before making the check.

Fit a new 'O' ring into the steering column adaptor plate and if necessary renew the eight rubber mounting bushes. Fit the adaptor plate to the transfer gearbox; tighten the four nuts progressively to avoid distorting the plate.

Fit the steering column assembly to the steering box assembly.

Fit a new 'O' ring to the rear end of the transfer gearbox and fit the small driven gear bush housing.

Whilst tightening the four 2 BA nuts on the bush housing the steering wheel should be continually rotated in each direction in order to ensure that the bush housing is centralized correctly.

### Steering column and box — To fit (Page N42 in Workshop Manual)

#### S3 cars only

Refit the steering column and steering box as a complete assembly to the car, carefully reversing the procedure given for removal in 'Steering column and steering box — To remove' of this Supplement. If necessary renew the rubber bushes on the steering box mounting arm.

When the steering column and steering box are in position remove the transfer gearbox level and filler plugs and add a quantity of the recommended lubricant until a flow is observed from the oil level plug hole. This will require approximately  $\frac{3}{4}$  pint (0.355 litres). Refit and tighten both plugs.

Prime and fill the steering system as described in 'Priming and filling the system' of this Supplement.

Thoroughly clean the chassis frame adjacent to the steering box, then road test the car and check for oil leaks.

# CHAPTER P

## CHASSIS FRAME

SECTION	PAGE
P 1 General Description . . . . .	P 1(S)

## CHAPTER P

# CHASSIS FRAME

### SECTION P 1 — GENERAL DESCRIPTION

(Page P1 in Workshop Manual)

For S3 cars the following three paragraphs should be read in place of the seventh.

All S3 chassis frames are provided with angled tunnels through the left-hand side member and the rear left-hand cruciform member to accommodate the 'through-the-frame' exhaust pipe run (see Figure P1 (S) of this

Supplement). These tunnels are lined with seamed steel tubing, arc welded into position in the frame.

The rear silencer front support bracket is positioned immediately behind the tunnel in the rear left-hand cruciform member.

The remaining information in this Section which applies to S2 cars is also applicable to S3 cars.

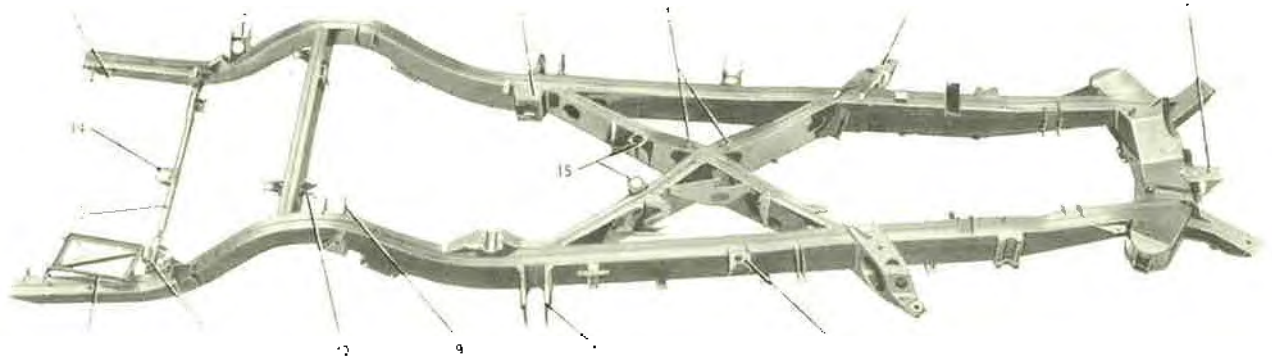

Fig. P1 (S) S3 chassis frame

- |                          |                            |                           |
|--------------------------|----------------------------|---------------------------|
| 1 BODY MOUNTING BRACKET  | 6 RADIATOR SUPPORT BRACKET | 11 REAR SHACKLE EYE       |
| 2 BODY MOUNTING BRACKET  | 7 BODY MOUNTING BRACKET    | 12 BATTERY CARRIER        |
| 3 REAR SHAGKLE ANCHORAGE | 8 BODY MOUNTING BRACKET    | 13 TUBULAR MEMBER         |
| 4 CRUCIFORM              | 9 BODY MOUNTING BRACKET    | 14 BODY MOUNTING BRACKET  |
| 5 BODY MOUNTING BRACKET  | 10 FUEL FILTER MOUNTING    | 15 BODY MOUNTING BRACKETS |

# CHAPTER Q

## EXHAUST SYSTEM

SECTION		PAGE
Q 1	Description . . . . .	Q 1(S)
Q 2	To Remove and Fit . . . . .	Q 2(S)

## CHAPTER Q

## EXHAUST SYSTEM

## SECTION Q1 — DESCRIPTION

(Page Q1 in Workshop Manual)

**S3 cars**

The information in this Section which applies to S2 cars is also applicable to S3 cars with the following Chassis Nos.

Rolls-Royce Silver Cloud III From SAZ1 to SAZ61 inclusive.

Bentley S3 From B2AV to B26AV inclusive.

**On all other S3 cars** the exhaust system is of the acoustic type.

The exhaust gases pass from the engine through two cast-iron manifolds and down two downtake pipes to enter a single pipe through a welded breeches piece.

The two downtake pipes are of 2 in. outside diameter.

The single exhaust pipe from the breeches piece to the front silencer passes along the outside of the chassis frame and is of 2½ in. outside diameter.

The exhaust gases flow through the front silencer along two perforated tubes, one being the inlet and one being the outlet. The tubes are set at an angle inside the silencer shell and are supported by a centrally situated plate which also acts as a stiffener for the silencer shell.

The silencer is almost rectangular in shape and its approximate external dimensions are 16 in. × 8½ in. × 8 in.

The underside of the car floor, above the front silencer and exhaust pipe is protected against heat by aluminium-asbestos shields.

The exhaust gases on leaving the front silencer flow through a single exhaust pipe, which passes through the chassis frame side member, through the rear left-

hand cruciform member and into the rear silencer.

The rear silencer is cylindrical in shape and is approximately 21½ in. long and 5½ in. in diameter.

The underside of the car floor above the rear silencer is protected against heat by an aluminium-asbestos shield.

The exhaust gases finally pass from the rear silencer through a high frequency damper and out through the exhaust tail pipe.

The damper is cylindrical in shape and is approximately 8 in. long and 4 in. in diameter. It consists of a perforated tube, around which is packed 7½ oz. of 'Rocksil' wool.

The outer surface of the front silencer is lagged with ½ in. thick asbestos sheet enclosed within a welded aluminium casing; this is the only lagged silencer in the system.

The silencers and the damper are manufactured from stainless steel as a protection against condensation corrosion.

The exhaust system is secured to the chassis frame in four places by 'Vibrashock' mountings.

The down pipe from the 'A' bank exhaust manifold, positioned on the right-hand side of the car, sweeps under the engine and is secured to a bracket on the left-hand side of the engine mounting, before joining the breeches piece on the outside of the chassis frame.

Copper-asbestos joints are fitted between the exhaust manifolds and the cylinder heads, the exhaust manifolds being secured to the cylinder heads by ½ in. diameter extension nuts.

Cupro-nickel joints are fitted between the exhaust downtake pipes and the exhaust manifolds.

All the other exhaust pipe joints are fitted with steel spherical sealing rings which are held in position by bridge type clamps.



## SECTION Q2 — TO REMOVE AND FIT

## Exhaust manifolds — To renew

## S3 cars only

Remove the oil level dipstick from the engine, then remove the bolt from the dipstick tube support bracket, together with the two setscrews and washers securing the dipstick tube to the engine sump; remove the dipstick tube. This procedure prevents accidental damage to the dipstick and tube and improves access to the exhaust manifold. Mask the dipstick hole in the sump to prevent the entry of foreign matter.

Remove the two union nuts attaching the choke stove pipes to the right-hand side exhaust manifold (see Fig. Q1 (S) of this Supplement).

Disconnect the down pipe flanges from the exhaust manifold by removing the three nuts and washers from each flange.

Remove the nut, bolt and washer from the 'A' bank down pipe mounting which is positioned on the left-hand side of the engine sump. Access to this mounting is facilitated by raising the car on a ramp.

Withdraw the down pipes from the exhaust manifolds.

Remove the sixteen extension nuts from the exhaust manifolds, then lift the manifolds from the studs (see Fig. Q2 (S) of this Supplement).

The manifolds have slotted holes in Nos. 1, 2 and 4 exhaust port flanges, counting from the front of the engine. The slotted holes allow for normal expansion and contraction without distortion of the manifolds. The slots are 0.325 in. wide and the drilled holes are 0.325 in. in diameter.

The exhaust manifolds should be checked for distortion using a straight edge across the joint faces; if necessary, the joint face should be re-faced.

The importance of the manifold faces being flat and square cannot be over-emphasised.

Assemble the exhaust manifolds by reversing the procedure given for their removal noting the following points.

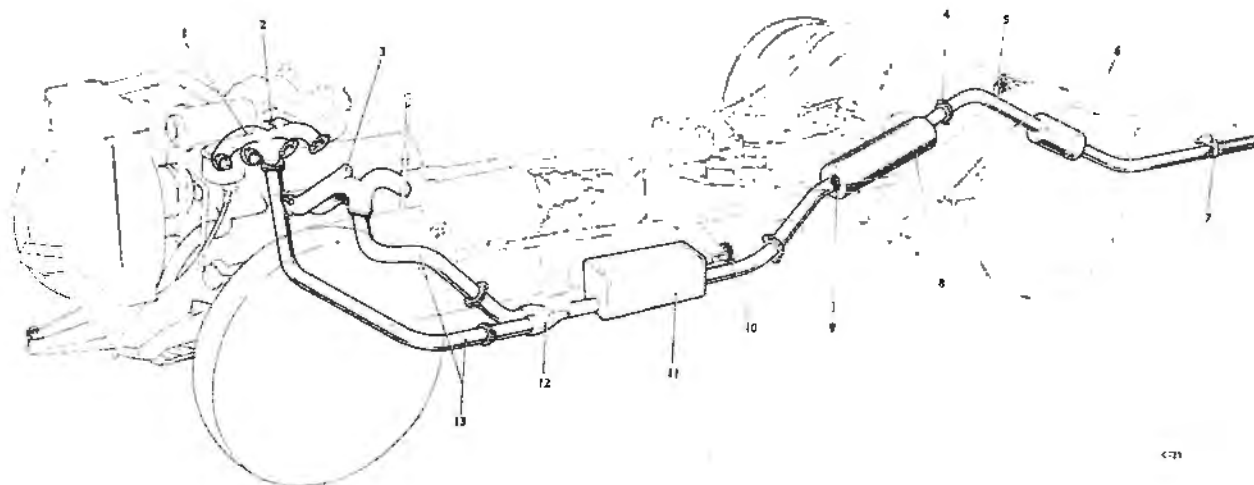

Fig. Q1 (S) Exhaust system — S3 cars (except Phantom V)

- 1 RIGHT-HAND MANIFOLD
- 2 CHOKE STOVE PIPES
- 3 LEFT-HAND MANIFOLD
- 4 BRIDGE CLAMP
- 5 DAMPER MOUNTING BRACKET

- 6 DAMPER
- 7 TAILPIPE MOUNTING BRACKET
- 8 REAR SILENCER
- 9 REAR SILENCER MOUNTING BRACKET

- 10 FRONT SILENCER MOUNTING BRACKET
- 11 FRONT SILENCER
- 12 BREECHES PIECE
- 13 DOWN PIPES

Fit new copper-asbestos joints between the exhaust manifolds and the cylinder heads and fit new cupro-nickel joints between the exhaust manifolds and the exhaust down pipes.

No jointing compound should be used on any of the joints but the extension nuts should be lubricated to ensure that no binding of the threads occurs during re-assembly.

The re-connecting of the right-hand side down pipe support should be carried out last.

Remove all adhesive tape masking from the sump and refit the oil level dipstick and tube.

All nuts and bolts should be evenly tightened.

After the engine has run sufficiently to reach its normal operating temperature, the nuts and bolts should again be evenly tightened.

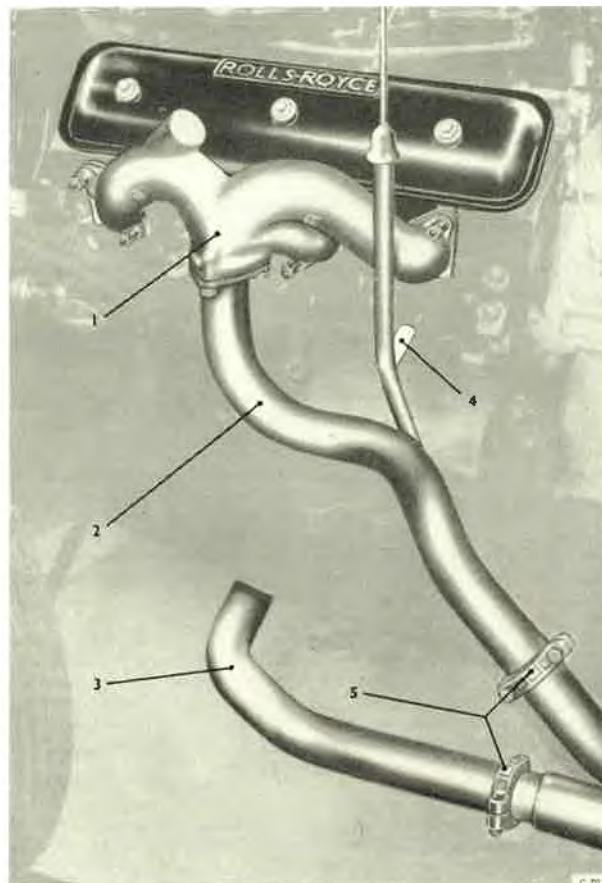

Fig. Q2 (S) Exhaust manifold and down pipes — S3 cars

- |                       |                                 |
|-----------------------|---------------------------------|
| 1 MANIFOLD            | 3 RIGHT-HAND DOWN PIPE          |
| 2 LEFT-HAND DOWN PIPE | 4 DIPSTICK TUBE SUPPORT BRACKET |
|                       | 5 CLAMPS                        |

## Exhaust down pipes — To renew

### S3 cars only

Remove the right-hand down pipes as follows

Remove the three nuts and washers securing the down pipe to the exhaust manifold flange.

Remove the two nuts, bolts and bridge clamps securing the down pipe to the breeches piece (see Fig. Q2 (S) of this Supplement).

Support the down pipe and remove the nut, bolt and washer securing the pipe to the engine mounting.

Withdraw the down pipe from the manifold flange studs; the pipe may then be removed and the spherical steel sealing ring retained for use when a replacement down pipe is fitted.

The procedure for the removal of the left-hand side down pipe is similar to that described above, a difference being that no supporting bracket is fitted to the left-hand pipe.

Assemble the exhaust down pipes by reversing the procedure given for their removal noting the following points.

New cupro-nickel flange joints must be fitted between the exhaust manifold flanges and the down take pipe flanges.

The spherical steel sealing rings should be clean and free from scale.

Smear the spherical faces of the sealing rings and the grooves in the clamps with a suitable graphite lubricant to ensure correct alignment of pieces on re-assembly.

All the nuts should be lubricated to ensure that no binding of the threads occurs during re-assembly.

## Front silencer — To renew

### S3 cars only

Remove the nuts, bolts and bridge clamps securing the down pipes to the breeches piece (see Fig. Q2 (S) of this Supplement).

Remove the bridge clamps from the outlet pipe of the front silencer (see Fig. Q1 (S) of this Supplement).

Remove the 2 BA nut, bolt and washer securing the flexible earthing strip to the front silencer mounting bracket.

Support the silencer while removing the setscrew securing the outlet pipe bracket to the 'Vibrashock' mounting.

Lower and remove the silencer assembly. Retain the spherical steel sealing rings for use when fitting the replacement silencer.

Assemble the front silencer by reversing the procedure given for its removal noting the following points.

Do not tighten any one bridge clamp securing the down pipes to the breeches piece until both bridge clamps are in position on the pipes.

The spherical steel sealing rings should be clean and free from scale.

Smear the spherical faces of the sealing rings and the grooves in the clamps with a suitable graphited lubricant to ensure correct alignment of the pieces on re-assembly.

All the nuts should be lubricated to ensure that no binding of the threads occurs during re-assembly.

### Rear silencer — To renew

#### S3 cars only

Remove the nuts, bolts and bridge clamps from the rear silencer inlet and outlet pipes, then remove the 2 BA nut, bolt and washer securing the flexible earthing strip to the rear silencer mounting bracket.

Support the rear silencer while removing the setscrew securing the silencer bracket to the 'Vibrashock' mounting (see Fig. Q1 (S) of this Supplement).

Lower and remove the silencer; retain the spherical steel sealing rings for use when fitting the replacement silencer.

Assemble the rear silencer by reversing the procedure given for its removal noting the following points.

The spherical steel sealing rings should be clean and free from scale.

Smear the spherical faces of the sealing rings and the grooves in the clamps with a suitable graphited lubricant to ensure correct alignment of the pieces on re-assembly.

All the nuts should be lubricated to ensure that no binding of the threads occurs during re-assembly.

### Damper box — To renew

#### S3 cars only

Remove the nuts, bolts and bridge clamps from the damper box inlet pipe, then remove the 2 BA nuts, bolts and washers securing the flexible earthing strips to the damper box and the tailpipe mounting bracket.

Remove the setscrew securing the tailpipe bracket to the 'Vibrashock' mounting (see Fig. Q1 (S) of this Supplement).

Support the damper box while removing the setscrew securing the damper box mounting bracket to the 'Vibrashock' mounting.

Lower and remove the damper box assembly; retain the spherical steel sealing ring for use when fitting the replacement damper box.

Assemble the damper box by reversing the procedure given for its removal noting the following points.

The spherical steel sealing ring should be clean and free from scale.

Smear the spherical faces of the sealing ring and the grooves in the clamps with a suitable graphited lubricant to ensure correct alignment of the pieces on re-assembly.

All the nuts should be lubricated to ensure that no binding of the threads occurs during re-assembly.

# CHAPTER R

## WHEELS AND TYRES

## CHAPTER R

## WHEELS AND TYRES

**Data**

(Page R 1 in Workshop Manual)

**Wheels — S3 cars only**

Rim diameter	15.00 in.
Rim width	6.00 in.

**Tyre sizes**

Silver Cloud III	8.20 in. × 15.00 in.
Bentley S3	8.20 in. × 15.00 in.
Bentley Continental S3	8.00 in. × 15.00 in.
Phantom V	8.90 in. × 15.00 in.

**Wheel balancing**

(Page R1 in Workshop Manual)

**For S3 cars the first paragraph to read**

The wheels are both statically and dynamically balanced on initial assembly and it is advisable to check the balance every 6000 miles (10,000 Kms.).

**Pressures**

(Page R2 in Workshop Manual)

**On S3 cars the recommended tyre pressures are:**

Silver Cloud III and Bentley S3 — 8.20 in. × 15.00 in. tyres		
Front	22 lb/sq.in. (1.55 kg/sq.cm.)	} Cold
Rear	27 lb/sq.in. (1.90 kg/sq.cm.)	
Silver Cloud III and Bentley S3 Long Wheelbase 8.20 in. × 15.00 in. tyres		
Front	23 lb/sq.in. (1.62 kg/sq.cm.)	} Cold
Rear	29 lb/sq.in. (2.04 kg/sq.cm.)	

Bentley Continental S3 8.00 in. × 15.00 in. tyres	Front	20 lb/sq.in. (1.41 kg/sq.cm.)	}	Cold for normal speed running
	Rear	25 lb/sq.in. (1.76 kg/sq.cm.)		
	Front	25 lb/sq.in. (1.76 kg/sq.cm.)	}	Cold for maximum speed running
	Rear	30 lb/sq.in. (2.11 kg/sq.cm.)		
Phantom V 8.90 in. × 15.00 in. tyres	Front	22 lb/sq.in. (1.55 kg/sq.cm.)	}	Cold
	Rear	27 lb/sq.in. (1.90 kg/sq.cm.)		

**Tyre service**  
(Page R3 in Workshop Manual)

**Interchanging wheels**

For S3 cars the first paragraph to read  
Every 6000 miles (10,000 Kms.) the wheels should be

interchanged in order to equalise wear between the  
front and rear tyres. This should be so arranged that  
the best tyres of the set are used on the front wheels.

The remaining information in this Section which  
applies to S2 cars is also applicable to S3 cars.

# CHAPTER S

## BODY

<b>SECTION</b>		<b>PAGE</b>
<b>S 1</b>	<b>Description and General Maintenance . . . . .</b>	<b>S 1(S)</b>
<b>S 10</b>	<b>Front and Rear Seats . . . . .</b>	<b>S 1(S)</b>
<b>S 12</b>	<b>Body Removal and Mounting . . . . .</b>	<b>S 2(S)</b>

## CHAPTER 5

# BODY

### SECTION S 1 — DESCRIPTION AND GENERAL MAINTENANCE

#### Description

(Page S1 in Workshop Manual)

**For S3 cars the eighth paragraph to read**

Individual type front seats are fitted, each one being provided with adjustment for the rake of the back rest.

The remaining information in this Section which applies to S2 cars is also applicable to S3 cars.

### SECTION S 10 — FRONT AND REAR SEATS

#### Front seat — To remove

(Page S29 in Workshop Manual)

##### S3 cars only

To remove either of the front seats, carry out the following procedure.

Depress the lever situated on the front valance of the seat and slide the seat forward to the limit of its travel.

Remove the two Allen screws from the rear end of each slide, then slide the seat backward to the limit of its travel and unscrew the two Allen screws from the front end of each slide.

It will then be possible to remove the front seat from the car, through the front door opening.

Care should be taken to ensure that the distance pieces at each end of the slides are retained.

The remaining information in this Section which applies to S2 cars is also applicable to S3 cars.



## SECTION 5 12—BODY REMOVAL AND MOUNTING

### Front wings — To remove

#### **S3 cars only**

Unscrew the nuts securing the front bumper to the chassis frame brackets then remove the front bumper.

Disconnect the fog lamp wiring at the foglamps, then remove the foglamps.

Unscrew the nuts and bolts securing the front fairings to the wings and front apron then remove the fairings.

Unscrew the nuts and bolts securing the front apron to the radiator grille and remove the front apron.

Remove the bonnet top, then remove the four setscrews which secure the radiator grille to the top edge of the front wing.

Remove the two setscrews securing the bottom edge of the radiator grille then remove the grille.

Disconnect the headlamp and side/flasher lamp wiring at the snap connectors situated on the wing valance and withdraw the wires through the rubber grommets in the wing valance.

Remove the side trim from the inside of the body below the facia panel then remove the four setscrews retaining the front wing to the body.

Open the front door and remove the setscrew situated at the rear of the front wing.

Remove the setscrew situated underneath the rear of the wing and also the setscrew which is situated inside the rear of the wing.

Remove the nuts and bolts securing the rear of the left-hand wing to the support stays.

Remove the four setscrews securing the wing to the valance plate at the front vertical edge of the wing.

Remove the self-tapping screws securing the stainless steel strip to the lower edge of the body, then remove the strip.

Mask the front edge of the front doors and the rear edge of the wings to prevent damage occurring whilst removing the wings.

Support the wing and remove the eleven setscrews securing the top edge of the valance to the wing.

Carefully remove the wing from the car.

### Front wings — To fit

#### **S3 cars only**

Fit the front wings by reversing the procedure given for removal, noting the following points.

Before fitting the front wings apply a suitable length of 'Prestik' sealing strip to the rear vertical edge of the wing and the top surface of the body sill.

Do not tighten any of the setscrews securing the wings until all the setscrews are in position.

Tighten the setscrews progressively ensuring that the wing is in alignment with the adjacent components.

After fitting the front wings it will be necessary to reset the headlamp as described in 'Headlamps-To adjust' in Section M9 of this Supplement.

The remaining information in this Section which applies to S2 cars is also applicable to S3 cars.

# WIRING DIAGRAM

Right-hand drive

**SILVER CLOUD III**

and

**BENTLEY S3**

© Rolls-Royce Limited (1962)

*Printed in England by  
Knight & Forster Limited, Water Lane Works, Leeds 11.*

TSD Publication 2076

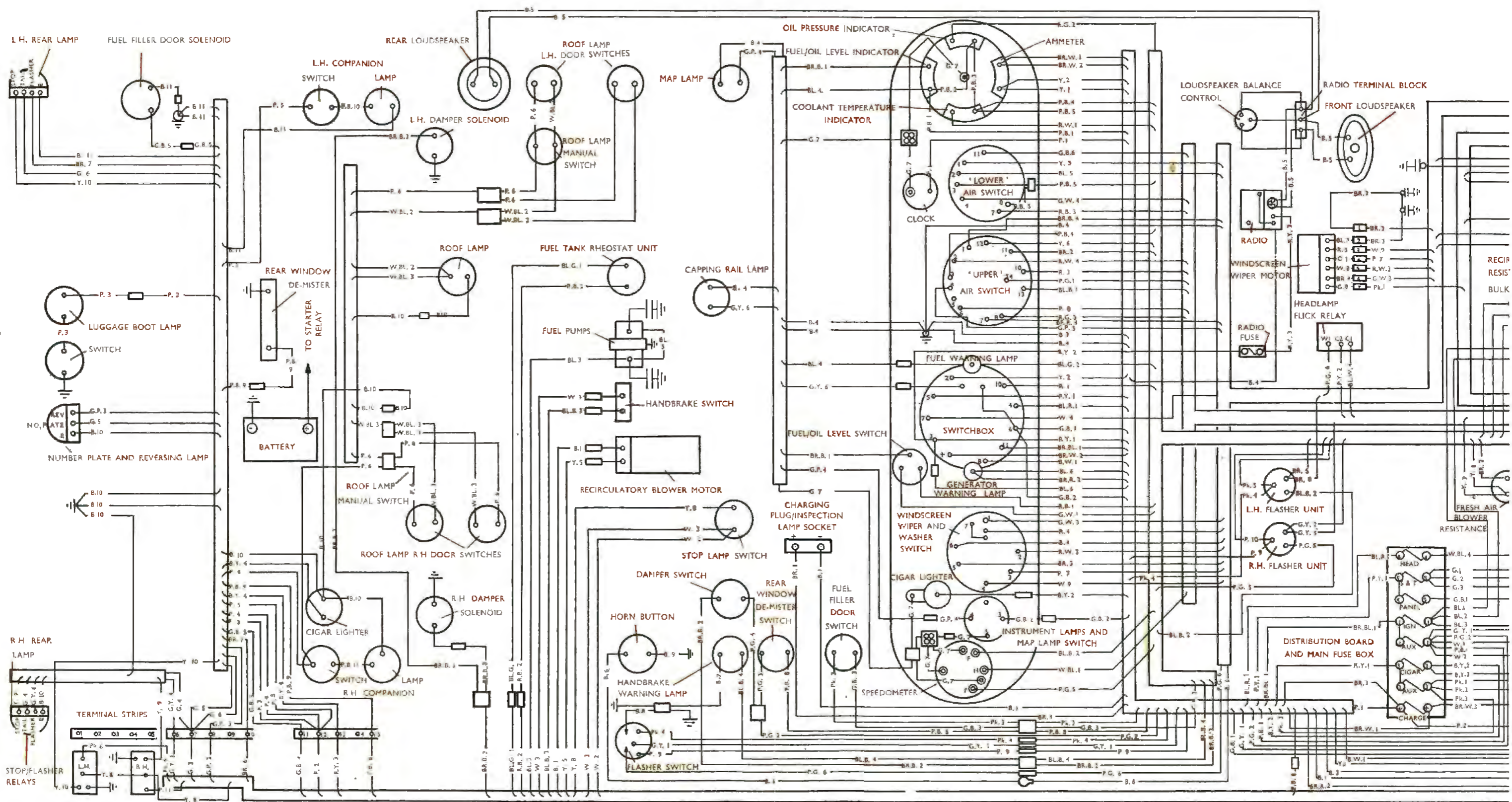

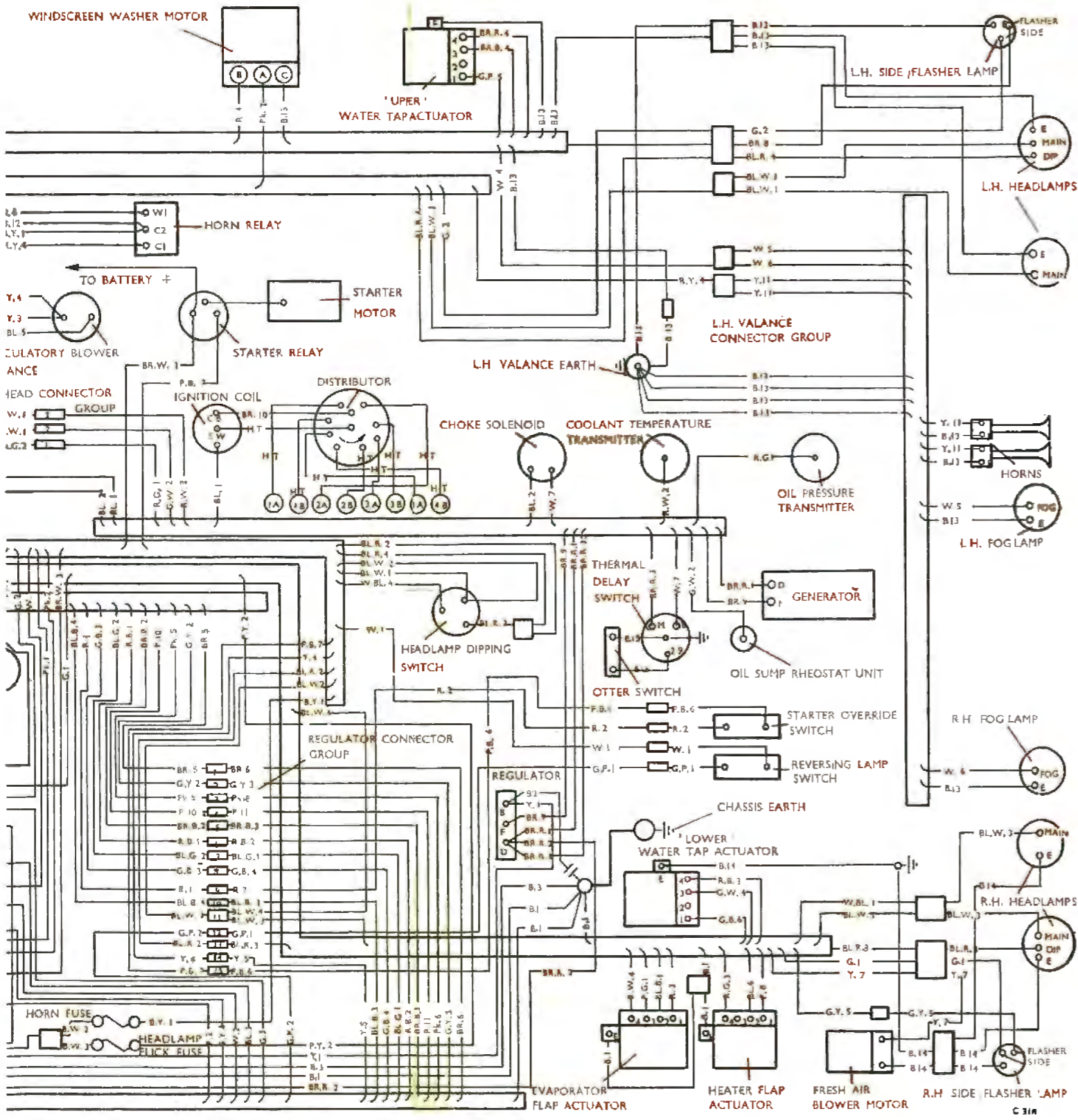

### KEY TO COLOUR CODING AND CONVENTIONAL SYMBOLS

R — RED W — WHITE Y — YELLOW G — GREEN B — BLACK  
 BL — BLUE BR — BROWN P — PURPLE PK — PINK O — ORANGE

These colours are often combined in pairs; e.g. P.Y. — PURPLE AND YELLOW, BR.R. — BROWN AND RED.

The figure attached as a suffix to each colour coding identifies the wire and enables its destination to be traced.

CODING	WIRING CONNECTIONS																																																																					
R.1	Switchbox 10																																																																					
R.2	Regulator Connector 9																																																																					
R.3	'Upper' Air Switch 10																																																																					
R.4	Windscreen Washer Switch																																																																					
R.5	Windscreen Wiper Connector 3																																																																					
R.W.1	Coolant Temperature Indicator																																																																					
R.W.2	Bulkhead Connector 3																																																																					
R.W.3	Windscreen Wiper Switch 2																																																																					
R.W.4	'Upper' Air Switch 2																																																																					
R.Y.1	Distribution Board 3																																																																					
R.Y.2	Switchbox 3																																																																					
R.Y.3	Radio Fuse																																																																					
R.Y.4	Horn Relay C1																																																																					
R.G.1	Oil Pressure Transmitter																																																																					
R.G.2	Bulkhead Connector 1																																																																					
R.G.3	Oil Pressure Indicator																																																																					
R.B.1	Fuel/Oil Level Switch																																																																					
R.B.2	Regulator Connector 6																																																																					
R.B.3	'Lower' Air Switch 7																																																																					
W.1	Distribution Board 11																																																																					
W.2	Distribution Board 11																																																																					
W.3	Stop Lamp Switch																																																																					
W.4	Switchbox 7																																																																					
W.5	LH Valance Connector Group																																																																					
W.6	RH Fog Lamp																																																																					
W.7	Thermal Delay Switch																																																																					
W.8	Windscreen Wiper Connector 5																																																																					
W.9	Windscreen Wiper Switch 4																																																																					
W.BL.1	RH Headlamps (Main)																																																																					
W.BL.2	Roof Lamp																																																																					
W.BL.3	Roof Lamp																																																																					
W.BL.4	Distribution Board 4																																																																					
Y.1	Regulator B																																																																					
Y.2	Ammeter																																																																					
Y.3	'Lower' Air Switch 1																																																																					
Y.4	Recirculatory Blower Resistance																																																																					
Y.5	Regulator Connector 14																																																																					
Y.6	Fresh Air Switch 12																																																																					
Y.7	Fresh Air Blower Resistance																																																																					
Y.8	Stop Lamp Switch																																																																					
Y.9	RH Stop/Flasher Relay C3																																																																					
Y.10	LH Stop/Flasher Relay C3																																																																					
Y.11	LH Valance Connector Group																																																																					
G.1	Distribution Board 5																																																																					
G.2	Distribution Board 5																																																																					
G.3	Distribution Board 5																																																																					
G.4	Terminal Strip 7																																																																					
G.5	Terminal Strip 7																																																																					
G.6	Terminal Strip 7																																																																					
G.7	Instrument/Map Lamp Switch 5																																																																					
G.8	Windscreen Wiper Connector 7																																																																					
G.W.1	Fuel/Oil Level Switch																																																																					
G.W.2	Bulkhead Connector 2																																																																					
G.W.3	Windscreen Wiper Switch 1																																																																					
G.W.4	'Lower' Air Switch 4																																																																					
G.Y.1	Distribution Board 11																																																																					
G.Y.2	RH Flasher Unit																																																																					
G.Y.3	Regulator Connector 2																																																																					
G.Y.4	Terminal Strip 6																																																																					
G.Y.5	RH Flasher Unit																																																																					
G.Y.6	Switchbox																																																																					
G.P.1	Reversing Lamp Switch																																																																					
G.P.2	Regulator Connector 12																																																																					
G.P.3	Terminal Strip 8																																																																					
G.P.4	Instrument/Map Lamp Switch 4																																																																					
G.P.5	'Upper' Air Switch 4																																																																					
G.B.1	Distribution Board 5																																																																					
G.B.2	Switchbox 6																																																																					
G.B.3	Fuel Filler Door Switch																																																																					
G.B.4	Regulator Connector 8																																																																					
G.B.5	Terminal Strip 11																																																																					
G.B.6	'Lower' Air Switch 11																																																																					
B.1	Flap Actuators E, Recirculatory Blower Motor, Charging Plug (-)																																																																					
B.2	Regulator B																																																																					
B.3	Regulator Earth																																																																					
B.4	Map Lamp, Capping Rail Lamp, Radio, Windscreen Wiper Switch 6																																																																					
B.5	Radio Amplifier																																																																					
B.6	Horn Button																																																																					
B.7	Hand Brake Warning Lamp																																																																					
B.8	Flasher Switch																																																																					
B.9	Horn Button																																																																					
B.10	Number Plate Lamp, Cigar Lighter, RH Rear Lamp, RH Companion Lamp, Roof Lamp, LH Rear Lamp, LH Companion Lamp, Fuel Filler Door Solenoid																																																																					
B.11	Horn Relay C2																																																																					
B.12	Horn, Fog Lamps, LH Side/Flasher Lamp, LH Headlamps, Windscreen Washer Motor 'C', 'Upper' Water Tap Actuator 'E'																																																																					
B.13	'Lower' Water Tap Actuator 'E', Fresh Air Blower Motor, RH Side/Flasher Lamp, RH Headlamps																																																																					
B.14	Otter Switch																																																																					
B.15	Otter Switch																																																																					
B.16	Otter Switch																																																																					
to Regulator Connector 9	to Evaporator Flap Actuator 1	to Windscreen Wiper Motor	to Bulkhead Connector 3	to Windscreen Wiper Connector 5	to Evaporator Flap Actuator 4	to Reversing Lamp Switch	to Stop Lamp Switch	to LH Fog Lamp	to Choke Solenoid	to Windscreen Wiper Motor	to Windscreen Wiper Connector 3	to Headlamp Warning Lamp (Speedometer)	to Roof Lamp LH Switches	to Roof Lamp RH Switches	to Headlamp Dipping Switch	to Ammeter	to Switchbox 2	to Recirculatory Blower Resistance	to Regulator Connector 14	to Recirculatory Blower Motor	to Fresh Air Blower Resistance	to Fresh Air Blower Motor	to Stop/Flasher Relay C2	to LH Rear Lamp (Stop)	to LH Rear Lamp (Stop)	to Horns	to RH Side Lamp	to LH Side Lamp	to Terminal Strip 7	to RH Rear Lamp (Tail)	to Number Plate Lamp	to LH Rear Lamp (Tail)	to Instrument Lamps	to Windscreen Wiper Motor	to Bulkhead Connector 2	to Oil Sump Rheostat Unit	to Windscreen Wiper Connector 6	to 'Lower' Water Tap Actuator 3	to Flasher Switch	to Regulator Connector 2	to Terminal Strip 6	to RH Rear Lamp (Flasher)	to RH Side/Flasher Lamp	to Capping Rail Lamp	to Regulator Connector 12	to Terminal Strip 8	to Reversing Lamp	to Map Lamp	to 'Upper' Water Tap Actuator 1	to Switchbox 6	to Instrument Lamps Switch 3	to Regulator Connector 8	to Terminal Strip 11	to Fuel Filler Door Solenoid	to 'Lower' Water Tap Actuator 1	to Regulator Earth	to Condenser	to Instrument Panel Earth	to Radio Loudspeakers	to Horn Relay W1	to Instrument Side Plate Earth	to Steering Column Earth	to Steering Column Earth	to Body RH Rear Earth	to Body LH Rear Earth	to Condenser	to LH Valance Earth	to RH Valance Earth	to Earth on Thermal Delay Switch	to Thermal Delay Switch

### CODING WIRING CONNECTIONS

B.W.1	Switchbox 8	to Horn Fuse Connector
B.W.2	Horn Fuse Connector	to Horn Fuse
B.W.3	Horn Fuse Connector	to Headlamp Flick Fuse
B.Y.1	Horn Fuse	to Horn Relay C2
B.Y.2	Distribution Board 3	to Facia Cigar Lighter
B.Y.3	Distribution Board 3	to Terminal Strip 13
B.Y.4	Terminal Strip 13	to RH Companion Cigar Lighter
BL.1	Distribution Board 11	to Ignition Coil (S.W.)
BL.2	Distribution Board 11	to Choke Solenoid
BL.3	Distribution Board 11	to Fuel Pumps
BL.4	Fuel/Oil Level Indicator	to Fuel Warning Lamp
BL.5	'Lower' Air Switch 2	to Recirculatory Blower Resistance
BL.6	Switchbox 3	to Generator Warning Lamp
BL.7	Windscreen Wiper Connector 2	to Windscreen Wiper Motor
BL.R.1	Distribution Board 4	to Switchbox 4
BL.R.2	Headlamp Dipping Switch	to Regulator Connector 13
BL.R.3	Regulator Connector 13	to RH Headlamp (Dip)
BL.R.4	Headlamp Dipping Switch	to LH Headlamp (Dip)
BL.W.1	Headlamp Dipping Switch	to LH Headlamp (Main)
BL.W.2	Headlamp Dipping Switch	to LH Headlamp (Main)
BL.W.3	Regulator Connector 11	to RH Headlamps (Main)
BL.W.4	Regulator Connector 11	to Headlamp Flick Relay 'C1'
BL.G.1	Fuel Tank Rheostat Unit	to Regulator Connector 7
BL.G.2	Regulator Connector 7	to Fuel Warning Lamp
BL.B.1	'Upper' Air Switch 13	to Evaporator Flap Actuator 2
BL.B.2	LH Flasher Unit	to LH Flasher Warning Lamp (Speedometer)
BL.B.3	Hand Brake Switch	to Regulator Connector 10
BL.B.4	Regulator Connector 10	to Hand Brake Warning Lamp
BR.1	Distribution Board (+)	to Charging Plug (-)
BR.2	'Upper' Air Switch 11	to Fresh Air Blower Resistance
BR.3	Windscreen Wiper Switch 5	to Windscreen Wiper Connectors 1 and 2
BR.4	Windscreen Wiper Connector 6	to Windscreen Wiper Motor
BR.5	LH Flasher Unit	to Regulator Connector 1
BR.6	Regulator Connector 1	to Terminal Strip 10
BR.7	Terminal Strip 10	to LH Rear Lamp (Flasher)
BR.8	LH Flasher Unit	to LH Side/Flasher Lamp
BR.9	Generator F	to Regulator F
BR.10	Ignition Coil (C.S.)	to Distributor (Contact Breaker)
BR.R.1	Generator D	to Regulator D
BR.R.2	Regulator D	to Generator Warning Lamp
BR.R.3	Regulator D	to Thermal Delay Switch
BR.R.4	'Upper' Air Switch 7	to 'Upper' Water Tap Actuator 4
BR.W.1	Distribution Board (+)	to Ammeter
BR.W.2	Ammeter	to Switchbox (+)
BR.W.3	Distribution Board (+)	to Starter Relay
BR.BL.1	Distribution Board 11	to Switchbox 11
BR.B.1	Fuel/Oil Level Switch	to Fuel/Oil Level Indicator
BR.B.2	Damper Switch	to Regulator Connector 5
BR.B.3	Regulator Connector 5	to Damper Solenoids
BR.B.4	'Upper' Air Switch 4	to 'Upper' Water Tap Actuator 3
P.1	Distribution Board (+)	to Clock
P.2	Distribution Board (+)	to Terminal Strip 12
P.3	Terminal Strip 12	to Luggage Boot Lamp
P.4	Terminal Strip 12	to RH Companion Switch
P.5	Terminal Strip 12	to LH Companion Switch
P.6	RH Companion Switch	to Roof Lamp Switches
P.7	Windscreen Wiper Switch 2	to Windscreen Wiper Connector 4
P.8	'Upper' Air Switch 6	to Heater Flap Actuator 1
P.9	Flasher Switch	to RH Flasher Unit
P.10	RH Flasher Unit	to Regulator Connector 4
P.11	Regulator Connector 4	to RH Stop/Flasher Relay W1
P.Y.1	Distribution Board 5	to Switchbox 5
P.Y.2	Headlamp Flick Fuse	to Headlamp Flick Relay C2
P.G.1	'Upper' Air Switch 14	to Evaporator Flap Actuator 3
P.G.2	Distribution Board 11	to Steering Column Connector Group
P.G.3	Steering Column Connector Group	to Rear Window De-mister Switch
P.G.4	Steering Column Connector Group	to Damper Switch
P.G.5	RH Flasher Unit	to RH Flasher Warning Lamp (Speedometer)
P.G.6	Flasher Switch	to Headlamp Flick Relay W1
P.B.1	Distribution Board 11	to Fuel/Oil Level Indicator
P.B.2	Fuel/Oil Level Indicator	to Oil Pressure Indicator
P.B.3	Oil Pressure Indicator	to Coolant Temperature Indicator
P.B.4	Coolant Temperature Indicator	to 'Upper' Air Switch 3
P.B.5	Coolant Temperature Indicator	to 'Lower' Air Switch 3 and 8
P.B.6	Starter Override Switch	to Regulator Connector 15
P.B.7	Regulator Connector 15	to Starter Relay
P.B.8	Rear Window De-mister Switch	to Terminal Strip 15
P.B.9	Terminal Strip 15	to Rear Window De-mister
P.B.10	Terminal Strip 15	to LH Companion Lamp
P.B.11	RH Companion Lamp Switch	to RH Companion Lamp
PK.1	Distribution Board 3	to Windscreen Wiper Connector 7
PK.2	Distribution Board 3	to Windscreen Washer Motor A
PK.3	Distribution Board 3	to Fuel Filler Door Switch
PK.4	Flasher Switch	to LH Flasher Unit
PK.5	LH Flasher Unit	to Regulator Connector 3
PK.6	Regulator Connector 3	to LH Stop/Flasher Relay W1
O.1	Windscreen Wiper Connector 4	to Windscreen Wiper Motor

In addition to the colour coding, the following symbols are employed throughout the diagram.

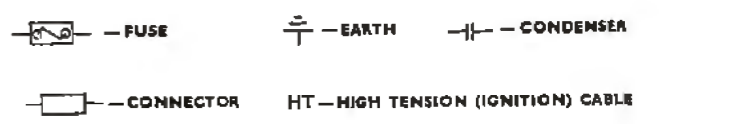

# WIRING DIAGRAM

Left-hand drive  
**SILVER CLOUD III**  
and  
**BENTLEY S3**

© Rolls-Royce Limited (1962)

*Printed in England by  
Knight & Farster Limited, Water Lane Works, Leeds 11.*

TSD Publication 2077

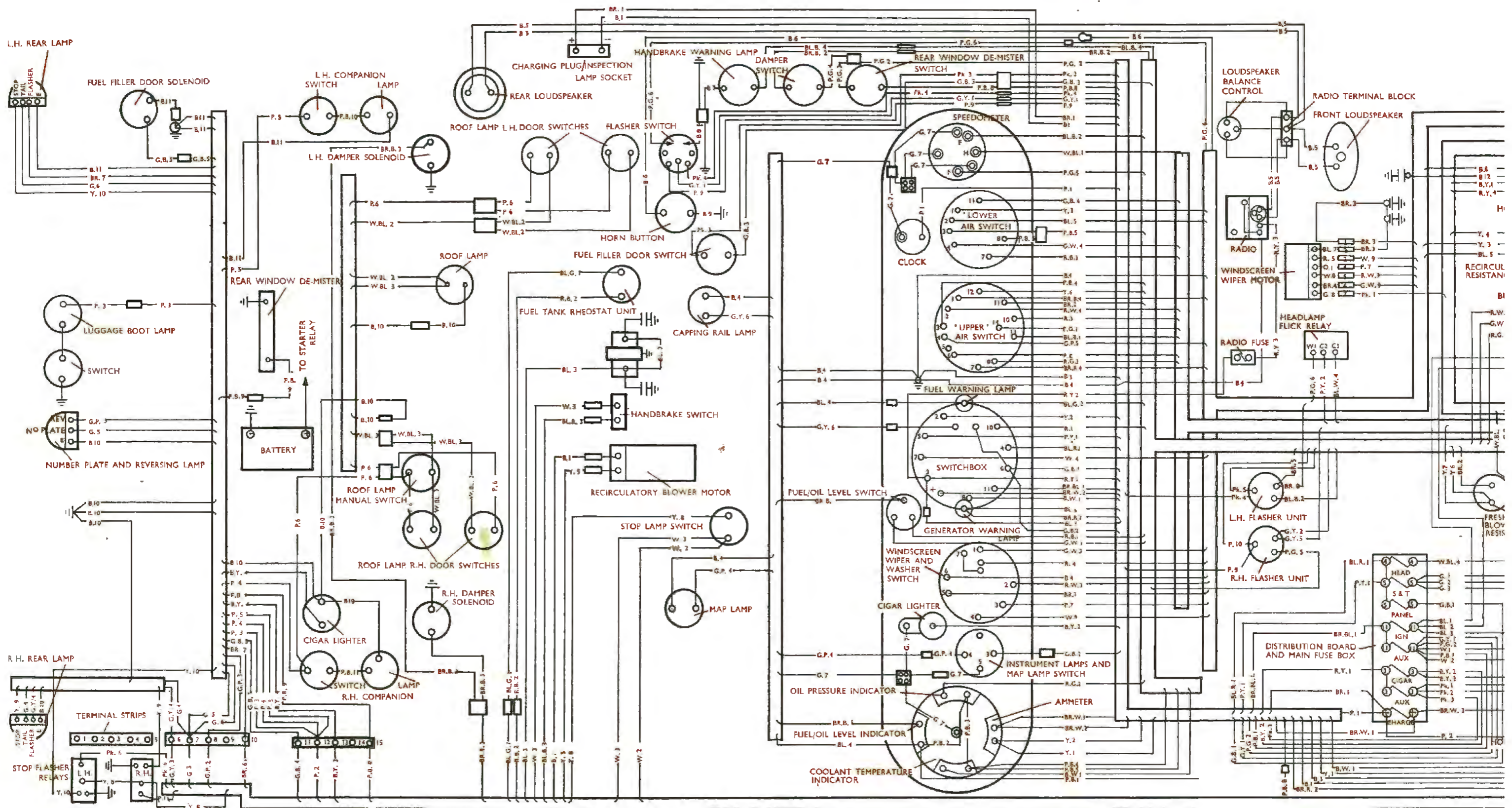

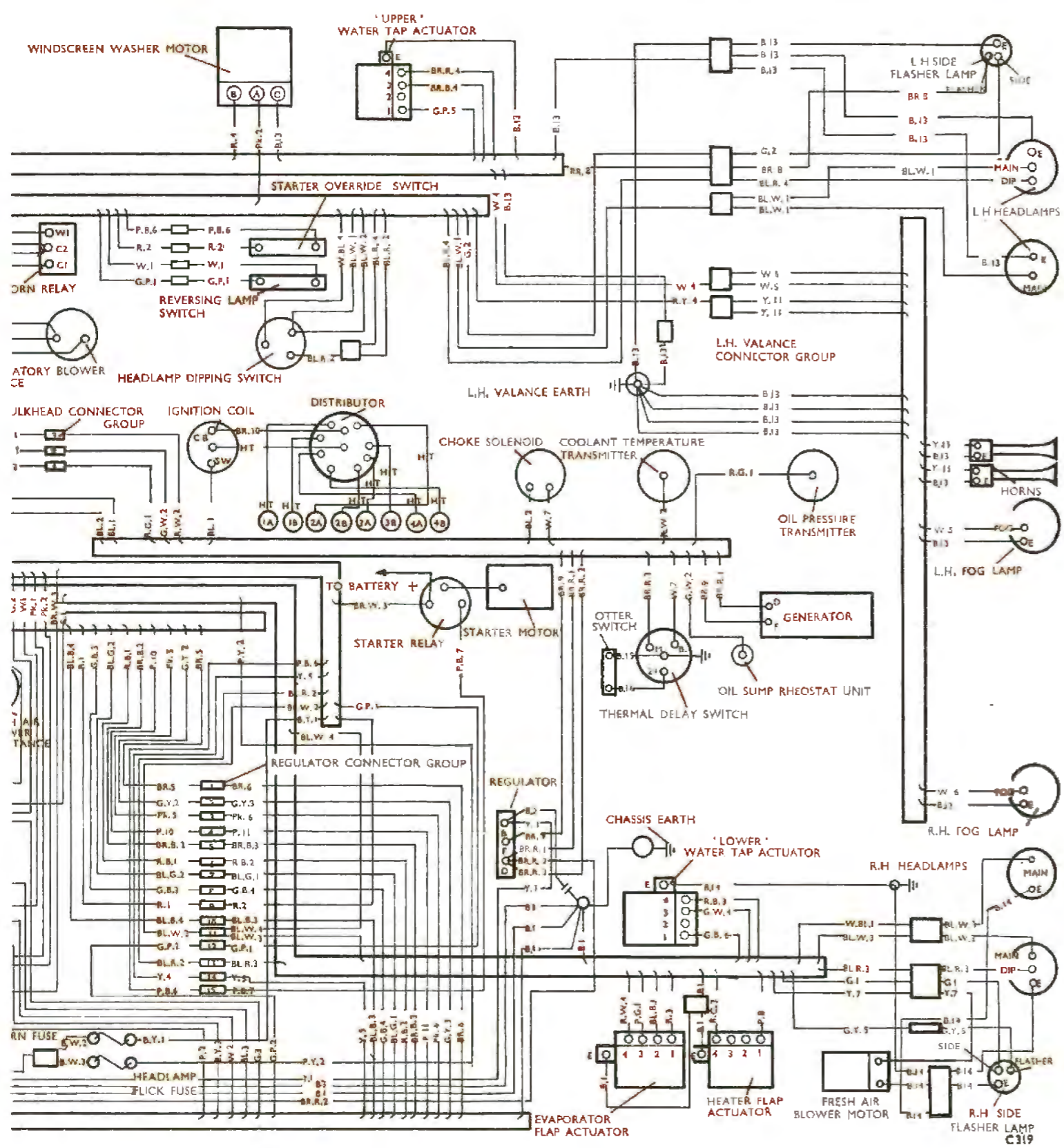

**KEY TO COLOUR CODING AND CONVENTIONAL SYMBOLS**

R — RED  
 BL — BLUE  
 W — WHITE  
 BR — BROWN  
 Y — YELLOW  
 P — PURPLE  
 G — GREEN  
 PK — PINK  
 B — BLACK  
 O — ORANGE

These colours are often combined in pairs; e.g. P.Y. — PURPLE AND YELLOW, B.R.R. — BROWN AND RED.

The figure attached as a suffix to each colour coding identifies the wire and enables its destination to be traced.

CODING		WIRING CONNECTIONS	
R.1	Switchbox 10	to	Regulator Connector 9
R.2	Regulator Connector 9	to	Starter Override Switch
R.3	'Upper' Air Switch 10	to	Evaporator Flap Actuator 1
R.4	Windscreen Washer Switch	to	Windscreen Washer Motor B
R.5	Windscreen Wiper Connector 3	to	Windscreen Wiper Motor
R.W.1	Coolant Temperature Indicator	to	Bulkhead Connector 3
R.W.2	Bulkhead Connector 3	to	Coolant Temperature Transmitter
R.W.3	Windscreen Wiper Switch 2	to	Windscreen Wiper Connector 5
R.W.4	'Upper' Air Switch 2	to	Evaporator Flap Actuator 4
R.T.1	Distribution Board 3	to	Switchbox 3
R.Y.2	Switchbox 3	to	Radio Fuse
R.Y.3	Radio Fuse	to	LH Valve Connector Group
R.Y.4	Horn Relay C1	to	Switchbox 3
R.G.1	Oil Pressure Transmitter	to	Bulkhead Connector 1
R.G.2	Bulkhead Connector 1	to	Oil Pressure Indicator
R.G.3	'Upper' Air Switch 8	to	Heater Flap Actuator 4
R.B.1	Fuel/Oil Level Switch	to	Regulator Connector 6
R.B.2	Regulator Connector 6	to	Fuel Tank Rheostat Unit
R.B.3	'Lower' Air Switch 7	to	'Lower' Water Tap Actuator 4
W.1	Distribution Board 11	to	Reversing Lamp Switch
W.2	Distribution Board 11	to	Stop Lamp Switch
W.3	Stop Lamp Switch	to	Hand Brake Switch
W.4	Switchbox 7	to	LH Valve Connector Group
W.5	LH Valve Connector Group	to	LH Fog Lamp
W.6	LH Valve Connector Group	to	RH Fog Lamp
W.7	Thermal Delay Switch B	to	Choke Solenoid
W.8	Windscreen Wiper Connector 5	to	Windscreen Wiper Motor
W.9	Windscreen Wiper Switch 4	to	Windscreen Wiper Connector 3
W.B.L.1	RH Headlamps (Main)	to	Headlamp Warning Lamp (Speedometer)
W.B.L.2	RH Headlamps (Main)	to	Roof Lamp LH Switches
W.B.L.3	Roof Lamp	to	Roof Lamp RH Switches
W.B.L.4	Distribution Board 4	to	Headlamp Dipping Switch
Y.1	Regulator B	to	Ammeter
Y.2	Ammeter	to	Switchbox 2
Y.3	'Lower' Air Switch 1	to	Recirculatory Blower Resistance
Y.4	Regulator Connector 14	to	Regulator Connector 14
Y.5	Regulator Connector 14	to	Recirculatory Blower Motor
Y.6	'Upper' Air Switch 12	to	Fresh Air Blower Resistance
Y.7	Fresh Air Blower Resistance	to	Fresh Air Blower Motor
Y.8	Stop Lamp Switch	to	Stop/Flasher Relays C2
Y.9	RH Stop/Flasher Relay C3	to	RH Rear Lamp (Stop)
Y.10	LH Stop/Flasher Relay C3	to	LH Rear Lamp (Stop)
Y.11	LH Valve Connector Group	to	Horns
G.1	Distribution Board 5	to	RH Side Lamp
G.2	Distribution Board 5	to	LH Side Lamp
G.3	Distribution Board 5	to	Terminal Strip 7
G.4	Terminal Strip 7	to	RH Rear Lamp (Tail)
G.5	Terminal Strip 7	to	Number Plate Lamp
G.6	Terminal Strip 7	to	LH Rear Lamp (Tail)
G.7	Instrument/Map Lamp Switch 5	to	Instrument Lamps
G.8	Windscreen Wiper Connector 7	to	Windscreen Wiper Motor
G.W.1	Fuel/Oil Level Switch	to	Bulkhead Connector 2
G.W.2	Bulkhead Connector 2	to	Oil Sump Rheostat Unit
G.W.3	Windscreen Wiper Switch 1	to	Windscreen Wiper Connector 6
G.W.4	'Lower' Air Switch 4	to	'Lower' Water Tap Actuator 3
G.Y.1	Distribution Board 11	to	Flasher Switch
G.Y.2	RH Flasher Unit	to	Regulator Connector 2
G.Y.3	Regulator Connector 2	to	Terminal Strip 11
G.Y.4	Terminal Strip 11	to	RH Rear Lamp (Flasher)
G.Y.5	RH Flasher Unit	to	RH Side/Flasher Lamp
G.Y.6	Switchbox	to	Capping Rail Lamp
G.P.1	Reversing Lamp Switch	to	Regulator Connector 12
G.P.2	Regulator Connector 12	to	Terminal Strip 8
G.P.3	Terminal Strip 8	to	Reversing Lamp
G.P.4	Instrument/Map Lamp Switch 4	to	'Upper' Water Tap Actuator 1
G.P.5	'Upper' Air Switch 4	to	Switchbox 6
G.B.1	Distribution Board 5	to	Instrument Lamps Switch 3
G.B.2	Switchbox 6	to	Regulator Connector 8
G.B.3	Fuel Filler Door Switch	to	Terminal Strip 11
G.B.4	Regulator Connector 8	to	Terminal Strip 11
G.B.5	Terminal Strip 11	to	Fuel Filler Door Solenoid
G.B.6	'Lower' Air Switch 11	to	'Lower' Water Tap Actuator 1
B.1	Flap Actuators E, Recirculatory Blower Motor, Charging Plug (-)	to	Regulator Earth
B.2	Regulator B	to	Condenser
B.3	Regulator Earth	to	Instrument Panel Earth
B.4	Map Lamp, Capping Rail Lamp, Radio, Windscreen Wiper Switch 6	to	Instrument Panel Earth
B.5	Radio Amplifier	to	Radio Loudspeakers
B.6	Horn Button	to	Horn Relay W1
B.7	Hand Brake Warning Lamp	to	Instrument Side Plate Earth
B.8	Flasher Switch	to	Steering Column Earth
B.9	Horn Button	to	Steering Column Earth
B.10	Number Plate Lamp, Cigar Lighter, RH Rear Lamp, RH Companion Lamp, Fuel Filler	to	Body RH Rear Earth
B.11	LH Rear Lamp, LH Companion Lamp, Fuel Filler	to	Body LH Rear Earth
B.12	Horn Relay C2	to	Condenser
B.13	Horns, Fog Lamps, LH Side/Flasher Lamp, LH Headlamps, Windscreen Washer Motor 'C', 'Upper' Water Tap Actuator 'E'	to	LH Valve Earth
B.14	'Lower' Water Tap Actuator 'E', Fresh Air Blower Motor, RH Side/Flasher Lamp, RH Headlamp	to	RH Valve Earth
B.15	Oster Switch	to	Earth on Thermal Delay Switch
B.16	Oster Switch	to	Thermal Delay Switch

CODING		WIRING CONNECTIONS	
B.W.1	Switchbox 8	to	Horn Fuse Connector
B.W.2	Horn Fuse Connector	to	Horn Fuse
B.W.3	Horn Fuse Connector	to	Headlamp Flick Fuse
B.Y.1	Horn Fuse	to	Horn Relay C2
B.Y.2	Distribution Board 3	to	Facia Cigar Lighter
B.Y.3	Distribution Board 3	to	Terminal Strip 13
B.Y.4	Terminal Strip 13	to	RH Companion Cigar Lighter
BL.1	Distribution Board 11	to	Ignition Coil (S.W.)
BL.2	Distribution Board 11	to	Choke Solenoid
BL.3	Distribution Board 11	to	Fuel Pumps
BL.4	Fuel/Oil Level Indicator	to	Fuel Warning Lamp
BL.5	'Lower' Air Switch 2	to	Recirculatory Blower Resistance
BL.6	Switchbox 3	to	Generator Warning Lamp
BL.7	Windscreen Wiper Connector 2	to	Windscreen Wiper Motor
BL.B.1	Distribution Board 4	to	Switchbox 4
BL.B.2	Headlamp Dipping Switch	to	Regulator Connector 13
BL.B.3	Regulator Connector 13	to	RH Headlamp (Dip)
BL.B.4	Headlamp Dipping Switch	to	LH Headlamp (Dip)
BL.W.1	Headlamp Dipping Switch	to	LH Headlamp (Main)
BL.W.2	Headlamp Dipping Switch	to	Regulator Connector 11
BL.W.3	Regulator Connector 11	to	RH Headlamps (Main)
BL.W.4	Regulator Connector 11	to	Headlamp Flick Relay 'C1'
BL.G.1	Fuel Tank Rheostat Unit	to	Regulator Connector 7
BL.G.2	Regulator Connector 7	to	Fuel Warning Lamp
BL.B.1	'Upper' Air Switch 13	to	Evaporator Flap Actuator 2
BL.B.2	LH Flasher Unit	to	LH Flasher Warning Lamp (Speedometer)
BL.B.3	Hand Brake Switch	to	Regulator Connector 10
BL.B.4	Regulator Connector 10	to	Hand Brake Warning Lamp
BR.1	Distribution Board (+)	to	Charging Plug (+)
BR.2	'Upper' Air Switch 11	to	Fresh Air Blower Resistance
BR.3	Windscreen Wiper Switch 5	to	Windscreen Wiper Connectors 1 and 2
BR.4	Windscreen Wiper Connector 6	to	Windscreen Wiper Motor
BR.5	LH Flasher Unit	to	Regulator Connector 1
BR.6	Regulator Connector 1	to	Terminal Strip 10
BR.7	Terminal Strip 10	to	LH Rear Lamp (Flasher)
BR.8	LH Flasher Unit	to	LH Side/Flasher Lamp
BR.9	Generator F	to	Regulator F
BR.10	Ignition Coil (C.B.)	to	Distributor (Contact Breaker)
BR.R.1	Generator D	to	Regulator D
BR.R.2	Regulator D	to	Generator Warning Lamp
BR.R.3	Regulator D	to	Thermal Delay Switch
BR.R.4	'Upper' Air Switch 7	to	'Upper' Water Tap Actuator 4
BR.W.1	Distribution Board (+)	to	Ammeter
BR.W.2	Ammeter	to	Switchbox (+)
BR.W.3	Distribution Board (+)	to	Starter Relay
BR.B.L.1	Distribution Board 11	to	Switchbox 11
BR.B.1	Fuel/Oil Level Switch	to	Fuel/Oil Level Indicator
BR.B.2	Damper Switch	to	Regulator Connector 5
BR.B.3	Regulator Connector 5	to	Damper Solenoids
BR.B.4	'Upper' Air Switch 1	to	'Upper' Water Tap Actuator 3
P.1	Distribution Board (+)	to	Clock
P.2	Distribution Board (+)	to	Terminal Strip 12
P.3	Luggage Boot Lamp	to	Luggage Boot Lamp
P.4	Terminal Strip 12	to	RH Companion Switch
P.5	Terminal Strip 12	to	LH Companion Switch
P.6	RH Companion Switch	to	Roof Lamp Switches
P.7	Windscreen Wiper Connector 3	to	Windscreen Wiper Connector 4
P.8	'Upper' Air Switch 6	to	Heater Flap Actuator 1
P.9	Flasher Switch	to	RH Flasher Unit
P.10	Regulator Connector 4	to	Regulator Connector 4
P.11	Regulator Connector 4	to	RH Stop/Flasher Relay W1
P.Y.1	Distribution Board 5	to	Switchbox 5
P.Y.2	Headlamp Flick Fuse	to	Headlamp Flick Relay C2
P.G.1	'Upper' Air Switch 14	to	Evaporator Flap Actuator 3
P.G.2	Distribution Board 11	to	Steering Column Connector Group
P.G.3	Steering Column Connector Group	to	Rear Window De-mister Switch
P.G.4	Steering Column Connector Group	to	Damper Switch
P.G.5	RH Flasher Unit	to	RH Flasher Warning Lamp (Speedometer)
P.G.6	Flasher Switch	to	Headlamp Flick Relay W1
P.B.1	Distribution Board 11	to	Fuel/Oil Level Indicator
P.B.2	Fuel/Oil Level Indicator	to	Oil Pressure Indicator
P.B.3	Oil Pressure Indicator	to	Coolant Temperature Indicator
P.B.4	Coolant Temperature Indicator	to	'Upper' Air Switch 3
P.B.5	Coolant Temperature Indicator	to	'Lower' Air Switch 3 and 8
P.B.6	Starter Override Switch	to	Regulator Connector 13
P.B.7	Regulator Connector 13	to	Starter Relay
P.B.8	Rear Window De-mister Switch	to	Terminal Strip 15
P.B.9	Terminal Strip 15	to	Rear Window De-mister
P.B.10	LH Companion Lamp Switch	to	LH Companion Lamp
P.B.11	RH Companion Lamp Switch	to	RH Companion Lamp
PK.1	Distribution Board 3	to	Windscreen Wiper Connector 7
PK.2	Distribution Board 3	to	Windscreen Washer Motor A
PK.3	Distribution Board 3	to	Fuel Filler Door Switch
PK.4	Flasher Switch	to	LH Flasher Unit
PK.5	LH Flasher Unit	to	Regulator Connector 3
PK.6	Regulator Connector 3	to	LH Stop/Flasher Relay W1
O.1	Windscreen Wiper Connector 4	to	Windscreen Wiper Motor

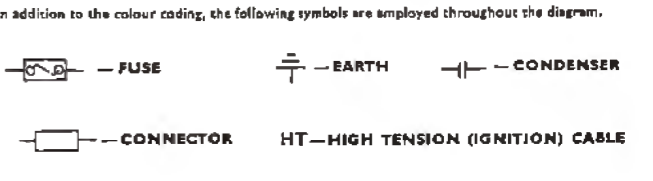

# WIRING DIAGRAM

## BENTLEY CONTINENTAL S3

This wiring diagram shows the differences between the electrical system of the Bentley Continental S3 and the Bentley Continental S2, therefore, it is necessary to read this diagram in conjunction with the wiring diagram for the Bentley Continental S2.

© Bentley Motors(1931)Ltd., (1963)



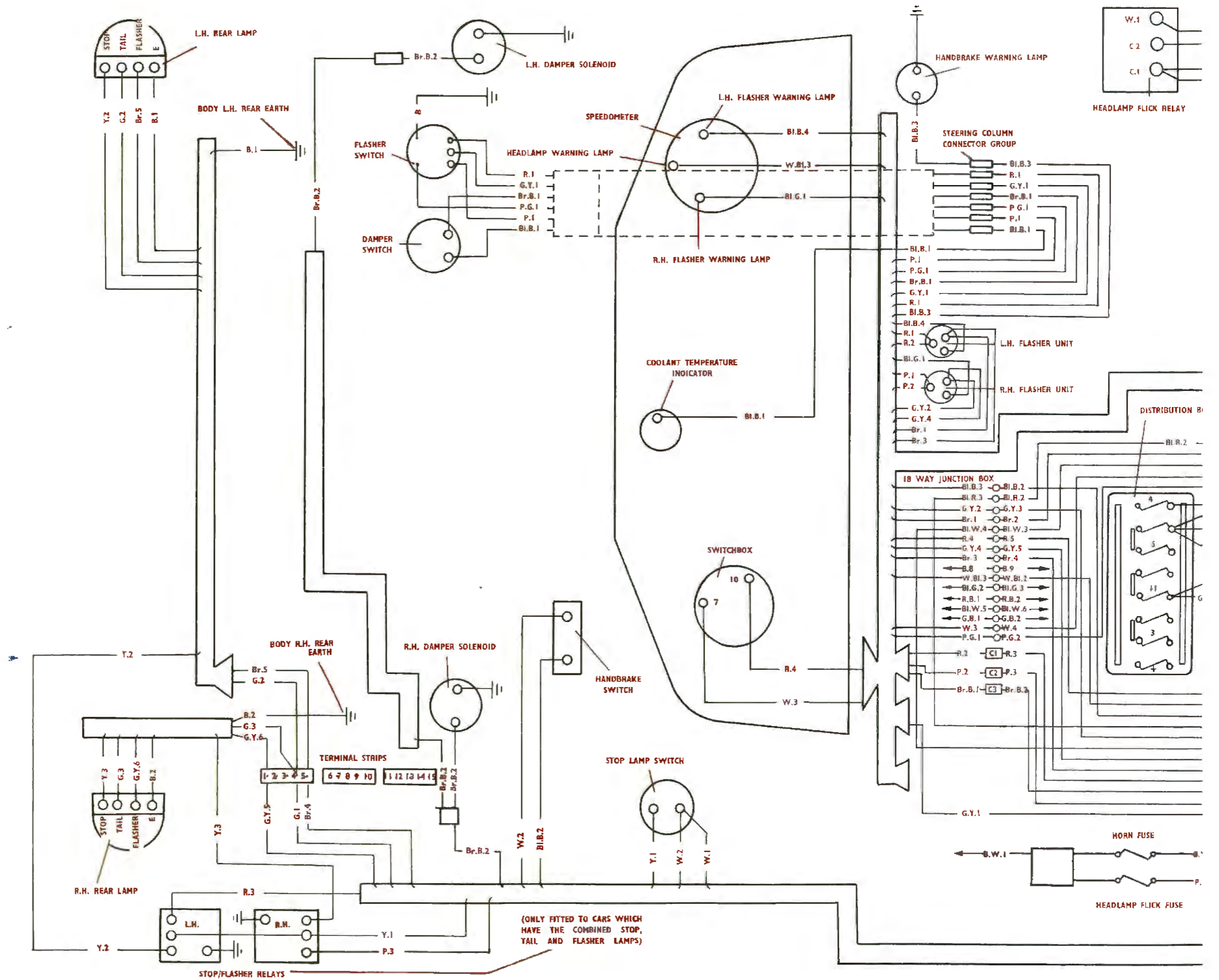

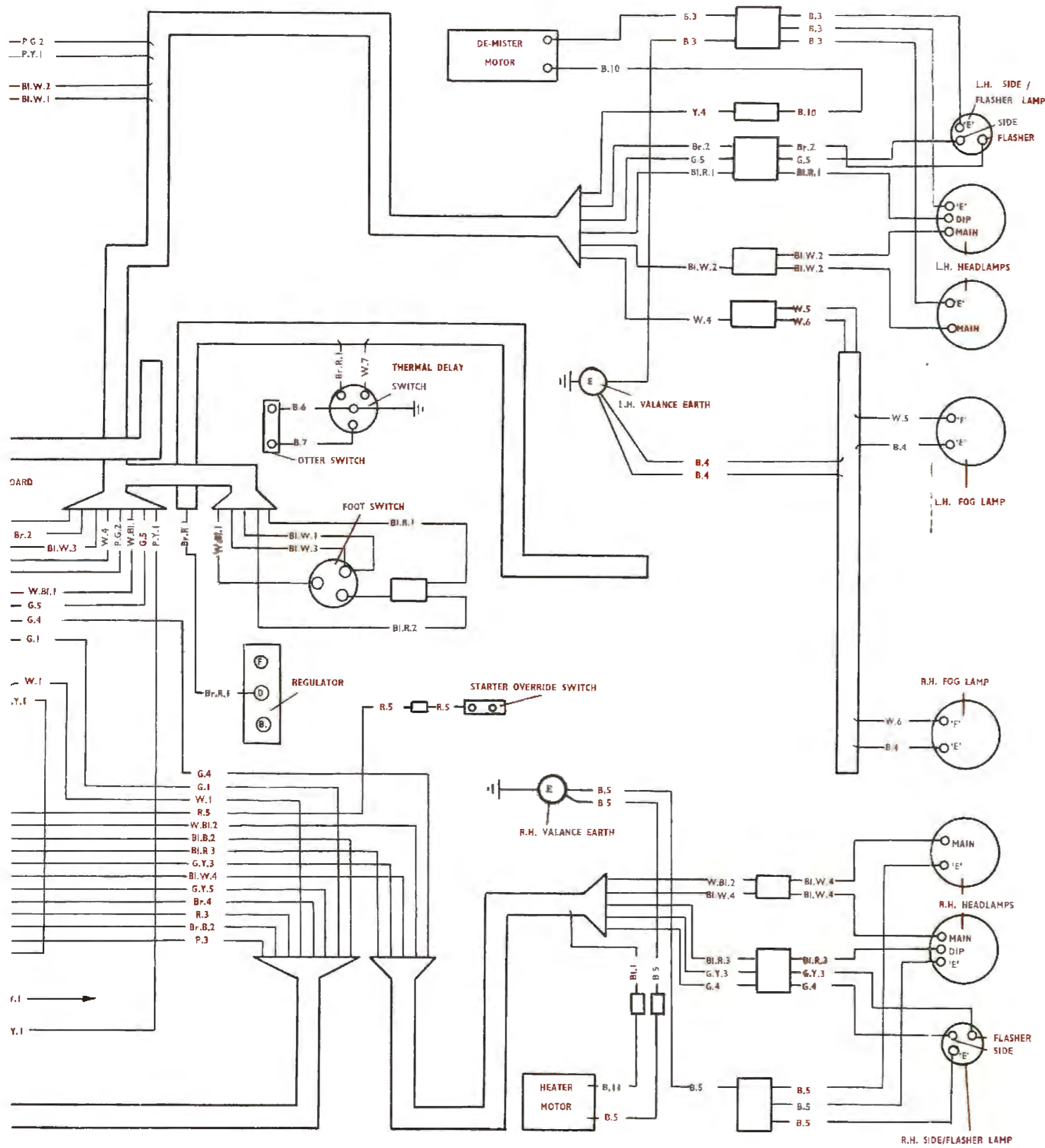

**KEY TO COLOUR CODING AND CONVENTIONAL SYMBOLS**

- R — RED      W — WHITE      Y — YELLOW      G — GREEN      B — BLACK**  
**Bl — BLUE      Br — BROWN      P — PURPLE      Pk — PINK      O — ORANGE**

These colours are often combined in pairs; e.g. P.Y. — PURPLE AND YELLOW, Br.R. — BROWN AND RED.

The figure attached as a suffix to each colour coding identifies the wire and enables its destination to be traced.

**CODING      WIRING CONNECTIONS**

<b>B.1</b>	L.H. Rear Lamp	to Body L.H. — Rear Earth
<b>B.2</b>	R.H. Rear Lamp	to Body R.H. — Rear Earth
<b>B.3</b>	De-mister Motor, L.H. Side/Flasher and L.H. Headlamps	to L.H. Valance Earth
<b>B.4</b>	Fog Lamps	to L.H. Valance Earth
<b>B.5</b>	Heater Motor, R.H. Side/Flasher and R.H. Headlamps	to R.H. Valance Earth
<b>B.6</b>	Otter Switch	to Earth on Thermal Delay Switch
<b>B.7</b>	Otter Switch	to Thermal Delay Switch
<b>B.8</b>	18-way Junction Box	to Horn Button
<b>B.9</b>	18-way Junction Box	to Horn Relay W1
<b>B.10</b>	Connector — De-mister Motor	to De-mister Motor
<b>B.11</b>	Connector — Heater Motor	to Heater Motor
<b>Bl.1</b>	Connector — Heater Motor	to Heater Motor Resistance
<b>Bl.B.1</b>	Coolant Temperature Indicator	to Damper Switch
<b>Bl.B.2</b>	Handbrake Switch	to 18-way Junction Box
<b>Bl.B.3</b>	18-way Junction Box	to Handbrake Warning Lamp
<b>Bl.B.4</b>	L.H. Flasher Unit	to L.H. Flasher Warning Lamp
<b>Bl.G.1</b>	R.H. Flasher Unit	to R.H. Flasher Warning Lamp
<b>Bl.G.2</b>	18-way Junction Box	to Fuel Warning Lamp
<b>Bl.G.3</b>	18-way Junction Box	to Fuel Tank Rheostat Unit
<b>Bl.R.1</b>	Footswitch	to L.H. Headlamp (Dip)
<b>Bl.R.2</b>	Footswitch	to 18-way Junction Box
<b>Bl.R.3</b>	18-way Junction Box	to R.H. Headlamp (Dip)
<b>Bl.W.1</b>	Footswitch	to Headlamp Flick Relay C1
<b>Bl.W.2</b>	Headlamp Flick Relay C1	to L.H. Twin Headlamps (Main)
<b>Bl.W.3</b>	Footswitch	to 18-way Junction Box
<b>Bl.W.4</b>	18-way Junction Box	to R.H. Twin Headlamps (Main)
<b>Bl.W.5</b>	18-way Junction Box	to Interior Lamp Switch
<b>Bl.W.6</b>	18-way Junction Box	to Interior Lamp
<b>Br.1</b>	L.H. Flasher Unit	to 18-way Junction Box
<b>Br.2</b>	18-way Junction Box	to L.H. Front Flasher
<b>Br.3</b>	L.H. Flasher Unit	to 18-way Junction Box
<b>Br.4</b>	18-way Junction Box	to Terminal Strip 5
<b>Br.5</b>	Terminal Strip 5	to L.H. Rear Flasher
<b>Br.B.1</b>	Damper Switch	to 18-way Junction Box Connector C3
<b>Br.B.2</b>	18-way Junction Box Connector C3	to Damper Solenoids
<b>Br.R.1</b>	Regulator D	to Thermal Delay Switch
<b>B.W.1</b>	Connector — Horn Fuse and Headlamp Flick Fuse	to Switchbox 8
<b>B.Y.1</b>	Horn Fuse	to Horn Relay C2
<b>G.1</b>	Distribution Board 5	to Terminal Strip 4
<b>G.2</b>	Terminal Strip 4	to L.H. Rear Lamp (Tail)
<b>G.3</b>	Terminal Strip 4	to R.H. Rear Lamp (Tail)
<b>G.4</b>	Distribution Board 5	to R.H. Side Lamp
<b>G.5</b>	Distribution Board 5	to L.H. Side Lamp
<b>G.B.1</b>	18-way Junction Box	to Fuel Filler Door Switch
<b>G.B.2</b>	18-way Junction Box	to Fuel Filler Door Solenoid
<b>G.Y.1</b>	Distribution Board 11	to Flasher Switch
<b>G.Y.2</b>	R.H. Flasher Unit	to 18-way Junction Box
<b>G.Y.3</b>	18-way Junction Box	to R.H. Front Flasher
<b>G.Y.4</b>	R.H. Flasher Unit	to 18-way Junction Box
<b>G.Y.5</b>	18-way Junction Box	to Terminal Strip 1
<b>G.Y.6</b>	Terminal Strip 1	to R.H. Rear Flasher
<b>P.1</b>	Flasher Switch	to R.H. Flasher Unit
<b>P.2</b>	R.H. Flasher Unit	to 18-way Junction Box Connector C2
<b>P.3</b>	18-way Junction Box Connector C2	to R.H. Stop/Flasher Relay
<b>P.G.1</b>	Flasher Switch	to 18-way Junction Box
<b>P.G.2</b>	18-way Junction Box	to Headlamp Flick Relay W1
<b>P.Y.1</b>	Headlamp Flick Fuse	to Headlamp Flick Relay C2
<b>R.1</b>	Flasher Switch	to L.H. Flasher Unit
<b>R.2</b>	L.H. Flasher Unit	to 18-way Junction Box Connector C1
<b>R.3</b>	18-way Junction Box Connector C1	to L.H. Stop/Flasher Relay
<b>R.4</b>	Switchbox 10	to 18-way Junction Box
<b>R.5</b>	18-way Junction Box	to Starter Override Switch
<b>R.B.1</b>	18-way Junction Box	to Fuel/Oil Level Switch
<b>R.B.2</b>	18-way Junction Box	to Fuel Tank Rheostat Unit
<b>W.1</b>	Distribution Board 11	to Stop Lamp Switch
<b>W.2</b>	Stop Lamp Switch	to Handbrake Switch
<b>W.3</b>	Switchbox 7	to 18-way Junction Box
<b>W.4</b>	18-way Junction Box	to Fog Lamp Connector
<b>W.5</b>	Fog Lamp Connector	to L.H. Fog Lamp
<b>W.6</b>	Fog Lamp Connector	to R.H. Fog Lamp
<b>W.7</b>	Thermal Delay Switch	to Choke Solenoid
<b>W.Bl.1</b>	Distribution Board 4	to Footswitch
<b>W.Bl.2</b>	Connector — R.H. Twin Headlamps	to 18-way Junction Box
<b>W.Bl.3</b>	18-way Junction Box	to Headlamp Main Beam Warning Lamp
<b>Y.1</b>	Stop Lamp Switch	to Stop/Flasher Relays
<b>Y.2</b>	L.H. Stop/Flasher Relay	to L.H. Rear Lamp (Stop)
<b>Y.3</b>	R.H. Stop/Flasher Relay	to R.H. Rear Lamp (Stop)
<b>Y.4</b>	De-mister Motor Connector	to De-mister Motor Resistance

In addition to the colour coding, the following symbols are employed throughout the diagram.

- FUSE      EARTH      CONNECTOR

# WIRING DIAGRAM

**ROLLS-ROYCE**

**SILVER CLOUD III WITH COACHWORK BY**

**H. J. MULLINER, PARK WARD LIMITED**

© Rolls-Royce Limited (1964)

Rolls-Royce policy is one of continuous engineering improvement and the right is reserved to revise the contents of this publication without prior notice.

*Printed in England by  
William Hodge and Chilvers Ltd, 86 Hatten Garden, London E.C.1*

(T.S.D. Publication 2183)



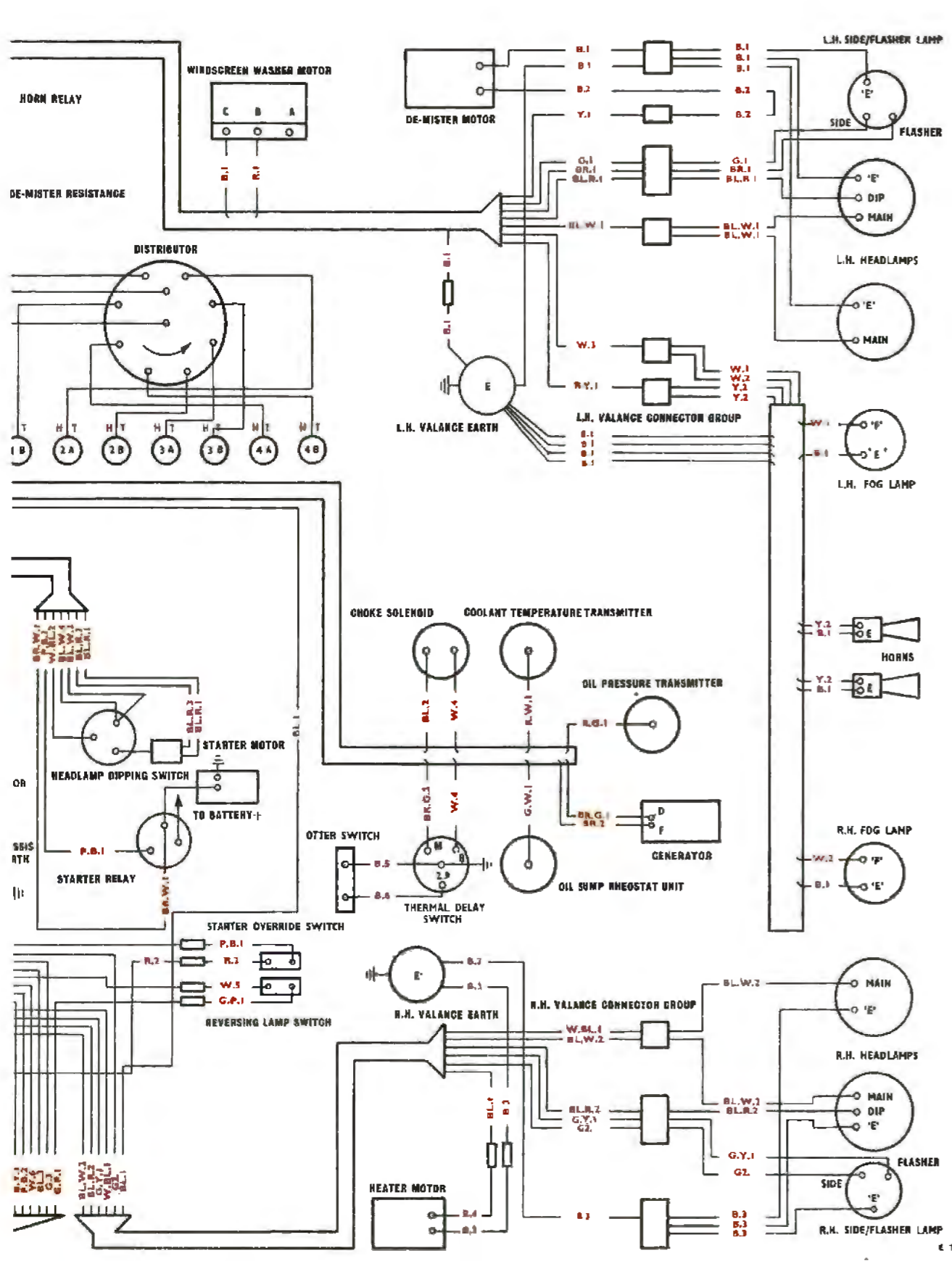

**KEY TO COLOUR CODING AND CONVENTIONAL SYMBOLS**

B = BLACK    BL = BLUE    BR = BROWN    G = GREEN    O = ORANGE  
 P = PURPLE    PK = PINK    R = RED    W = WHITE    Y = YELLOW

These colours are often combined in pairs; e.g. P.Y. = PURPLE AND YELLOW, BR.R. = BROWN AND RED.

The figures attached as a suffix to each colour coding identifies the wire and enables its destination to be traced.

CODING	WIRING CONNECTIONS
B.1	De-mister blower motor, L.H. side/flasher lamp, L.H. headlamps, fog lamps, horns and windscreen washer motor
B.2	De-mister blower motor
B.3	Heater blower motor, R.H. headlamps and R.H. side/flasher lamp
B.4	Heater blower motor
B.5	Oster switch
B.6	Oster switch
B.7	Regulator B
B.8	Regulator earth
B.9	Chassis earth
B.10	Chassis earth
B.11	Horn relay W1
B.12	Junction box 11
B.13	Radio
B.14	Radio, ignition switch lamp and windscreen wiper and washer switch 6
B.15	Radio terminal block
B.16	L.H. rear flasher lamp, L.H. stop/tail lamp and fuel filler door solenoid
B.17	Number plate lamps, roof lamp, reverse lamp, R.H. rear flasher lamp and R.H. stop/tail lamp
B.18	Flasher switch
B.19	Horn relay C2
B.W.1	Switchbox B
B.W.2	Horn fuse connector
B.W.3	Horn fuse connector
B.Y.1	Distribution board 3
B.Y.2	Horn fuse
B.Y.3	Cigar lighter
BL.1	R.H. valance connector group
BL.2	Distribution board 11
BL.3	Distribution board 11
BL.4	Distribution board 11
BL.5	Heater resistance
BL.6	Windscreen wiper motor connector 2
BL.7	De-mister resistance
BL.8	Fuel/oil level indicator
BL.9	Switchbox 3
BL.B.1	Junction box 3
BL.B.2	Junction box 3
BL.B.3	L.H. flasher unit
BL.G.1	Ignition coil
BL.G.2	Junction box 13
BL.G.3	Junction box 13
BL.R.1	L.H. headlamp (dip)
BL.R.2	R.H. headlamp (dip)
BL.R.3	Junction box 4
BL.R.4	Switchbox 4
BL.W.1	L.H. headlamps (main)
BL.W.2	R.H. headlamps (main)
BL.W.3	Junction box 7
BL.W.4	Headlamp dipping switch
BL.W.5	Junction box 15
BL.W.6	Junction box 15
BL.W.7	Terminal strip
BL.W.8	R.H. door connector
BL.W.9	L.H. door connector
BR.1	L.H. front flasher lamp
BR.2	Generator F
BR.3	Junction box 10
BR.4	Distribution board (1)
BR.5	L.H. flasher unit
BR.6	Windscreen wiper and washer switch 5
BR.7	Junction box 10
BR.8	Terminal strip
BR.B.1	Bulkhead connector
BR.B.2	Bulkhead connector
BR.B.3	Fuel/oil level indicator
BR.BL.1	Switchbox 11
BR.G.1	Generator D
BR.G.2	Regulator WL
BR.G.3	Regulator WL
BR.W.1	Starter relay
BR.W.2	Distribution board (+)
BR.W.3	Ammeter
G.1	L.H. side lamp
G.2	Distribution board 5
G.3	Distribution board 5
G.4	Instrument lamps
G.5	Terminal strip
G.6	Terminal strip
G.7	Terminal strip
G.8	Windscreen wiper motor
G.B.1	Junction box 16
G.B.2	Distribution board 5
G.B.3	Junction box 16
G.B.4	Switchbox
G.B.5	Terminal strip
G.P.1	Reversing lamp switch
G.P.2	Terminal strip
G.W.1	Oil sump rheostat unit
G.W.2	Windscreen wiper motor connector 6
G.Y.1	R.H. front flasher lamp
G.Y.2	Junction box 9
G.Y.3	Distribution board 11
G.Y.4	R.H. flasher unit
G.Y.5	R.H. flasher unit
G.Y.6	Switchbox
G.Y.7	Terminal strip
O.1	Windscreen wiper motor
PK.1	Windscreen wiper motor connector 7
PK.2	Distribution board 3
P.1	Distribution board (+)
P.2	Boot lamp switch
P.3	Distribution board (+)
P.4	R.H. flasher unit
P.5	Windscreen wiper and washer switch 3
P.6	Clock
P.7	Terminal strip
P.8	Terminal strip
P.9	R.H. door switch connector
P.B.1	Starter override switch
P.B.2	Rear window de-mister switch
P.B.3	Distribution board 11
P.B.4	Facia connector group
P.B.5	Oil pressure indicator
P.B.6	Oil pressure indicator
P.B.7	Revolution counter
P.B.8	Coolant temperature indicator
P.B.9	Coolant temperature indicator
P.B.10	Facia connector group
P.B.11	Terminal strip
P.G.1	Junction box 18
P.G.2	Junction box 18
P.G.3	R.H. flasher warning lamp (speedometer)
P.Y.1	Distribution board 5
P.Y.2	Headlamp flasher fuse
R.1	Windscreen washer motor
R.2	Starter override switch
R.3	Junction box 8
R.4	L.H. flasher unit
R.5	Windscreen wiper motor connector 3
R.B.1	Junction box 14
R.B.2	Junction box 14
R.G.1	Oil pressure transmitter
R.W.1	Coolant temperature transmitter
R.W.2	Windscreen wiper motor connector 5
R.Y.1	L.H. valance connector group
R.Y.2	Switchbox 3
R.Y.3	Switchbox 3
W.1	L.H. fog lamp
W.2	R.H. fog lamp
W.3	L.H. valance connector group
W.4	Choke solenoid
W.5	Distribution board 11
W.6	Distribution board 11
W.7	Switchbox 7
W.8	Windscreen wiper and washer switch 4
W.9	Windscreen wiper motor connector 5
W.10	Stop lamp switch
W.BL.1	R.H. valance connector group
W.BL.2	Headlamp dipping switch
W.BL.3	Headlamp warning lamp (speedometer)
W.BL.4	Roof lamp
W.BL.5	Roof lamp
Y.1	L.H. valance connector group
Y.2	Horns
Y.3	De-mister resistance
Y.4	Heater resistance
Y.5	Regulator B
Y.6	Ammeter
Y.7	Stop lamp switch
Y.8	Terminal strip
Y.9	Terminal strip

CODING	WIRING CONNECTIONS
G.P.1	Reversing lamp switch
G.P.2	Terminal strip
G.W.1	Oil sump rheostat unit
G.W.2	Windscreen wiper motor connector 6
G.Y.1	R.H. front flasher lamp
G.Y.2	Junction box 9
G.Y.3	Distribution board 11
G.Y.4	R.H. flasher unit
G.Y.5	R.H. flasher unit
G.Y.6	Switchbox
G.Y.7	Terminal strip
O.1	Windscreen wiper motor
PK.1	Windscreen wiper motor connector 7
PK.2	Distribution board 3
P.1	Distribution board (+)
P.2	Boot lamp switch
P.3	Distribution board (+)
P.4	R.H. flasher unit
P.5	Windscreen wiper and washer switch 3
P.6	Clock
P.7	Terminal strip
P.8	Terminal strip
P.9	R.H. door switch connector
P.B.1	Starter override switch
P.B.2	Rear window de-mister switch
P.B.3	Distribution board 11
P.B.4	Facia connector group
P.B.5	Oil pressure indicator
P.B.6	Oil pressure indicator
P.B.7	Revolution counter
P.B.8	Coolant temperature indicator
P.B.9	Coolant temperature indicator
P.B.10	Facia connector group
P.B.11	Terminal strip
P.G.1	Junction box 18
P.G.2	Junction box 18
P.G.3	R.H. flasher warning lamp (speedometer)
P.Y.1	Distribution board 5
P.Y.2	Headlamp flasher fuse
R.1	Windscreen washer motor
R.2	Starter override switch
R.3	Junction box 8
R.4	L.H. flasher unit
R.5	Windscreen wiper motor connector 3
R.B.1	Junction box 14
R.B.2	Junction box 14
R.G.1	Oil pressure transmitter
R.W.1	Coolant temperature transmitter
R.W.2	Windscreen wiper motor connector 5
R.Y.1	L.H. valance connector group
R.Y.2	Switchbox 3
R.Y.3	Switchbox 3
W.1	L.H. fog lamp
W.2	R.H. fog lamp
W.3	L.H. valance connector group
W.4	Choke solenoid
W.5	Distribution board 11
W.6	Distribution board 11
W.7	Switchbox 7
W.8	Windscreen wiper and washer switch 4
W.9	Windscreen wiper motor connector 5
W.10	Stop lamp switch
W.BL.1	R.H. valance connector group
W.BL.2	Headlamp dipping switch
W.BL.3	Headlamp warning lamp (speedometer)
W.BL.4	Roof lamp
W.BL.5	Roof lamp
Y.1	L.H. valance connector group
Y.2	Horns
Y.3	De-mister resistance
Y.4	Heater resistance
Y.5	Regulator B
Y.6	Ammeter
Y.7	Stop lamp switch
Y.8	Terminal strip
Y.9	Terminal strip

In addition to the colour coding, the following symbols are employed throughout the diagram:

FUSE   
 EARTH   
 CONDENSER  
 CONNECTOR  
 HT — HIGH TENSION (IGNITION) CABLE

# SUPPLEMENTARY WIRING DIAGRAM

**ROLLS-ROYCE**  
**SILVER CLOUD III WITH COACHWORK BY**  
**H. J. MULLINER, PARK WARD LIMITED**

This wiring diagram is provided to show the additional wiring for cars fitted with electrically operated actuators for the heating, demisting and ventilation system.

© Rolls-Royce Limited ( 1966 )

Rolls-Royce policy is one of continuous engineering improvement and the right is reserved to revise the contents of this publication without prior notice.

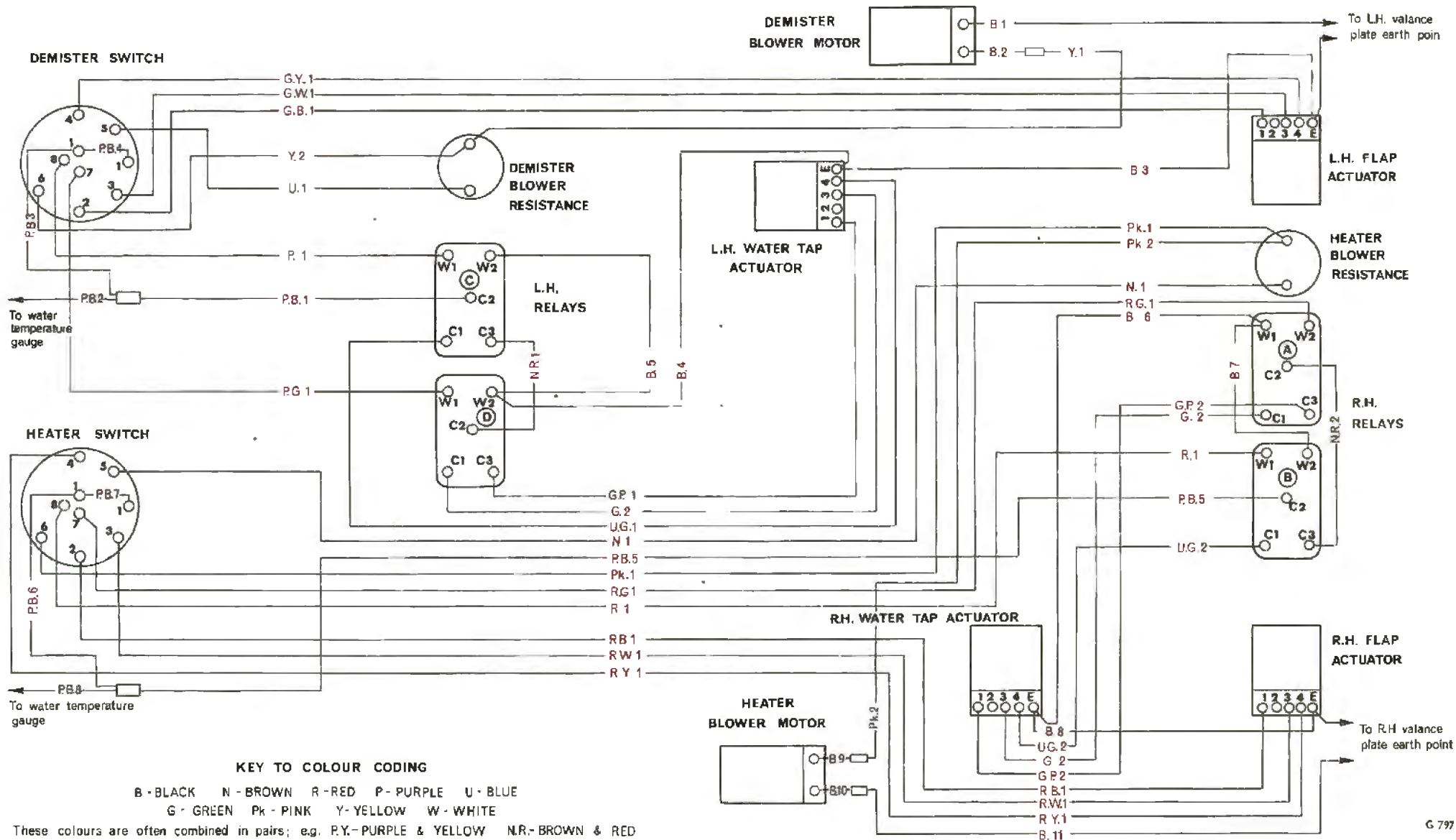

# WIRING DIAGRAM

## PHANTOM V

Chassis No. 5.VA.1 onwards

© Rolls-Royce Limited (1963)

*Printed in England by  
Knight & Forster Limited, Water Lane Works, Leeds 11.*

TSD Publication 2123



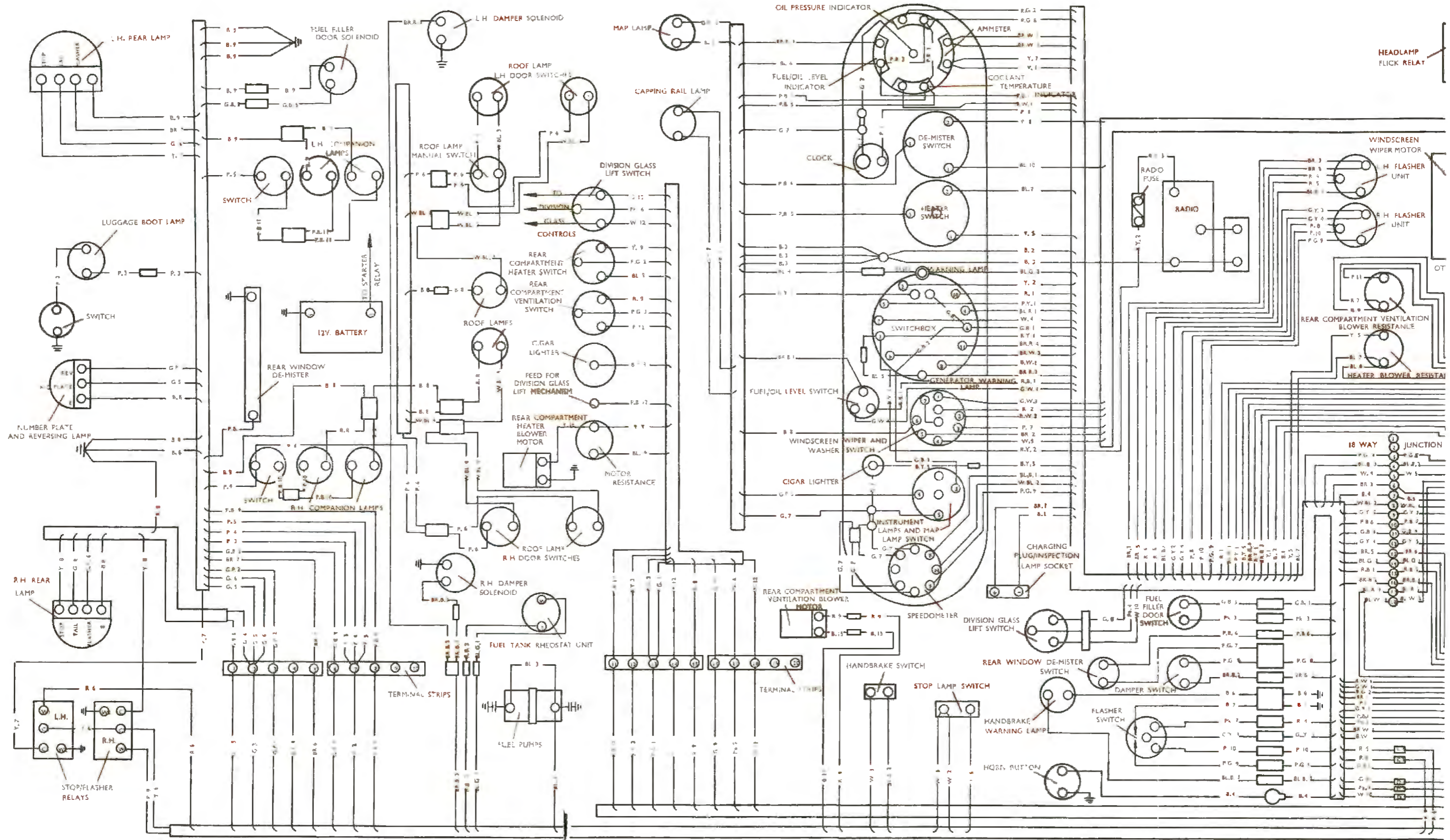

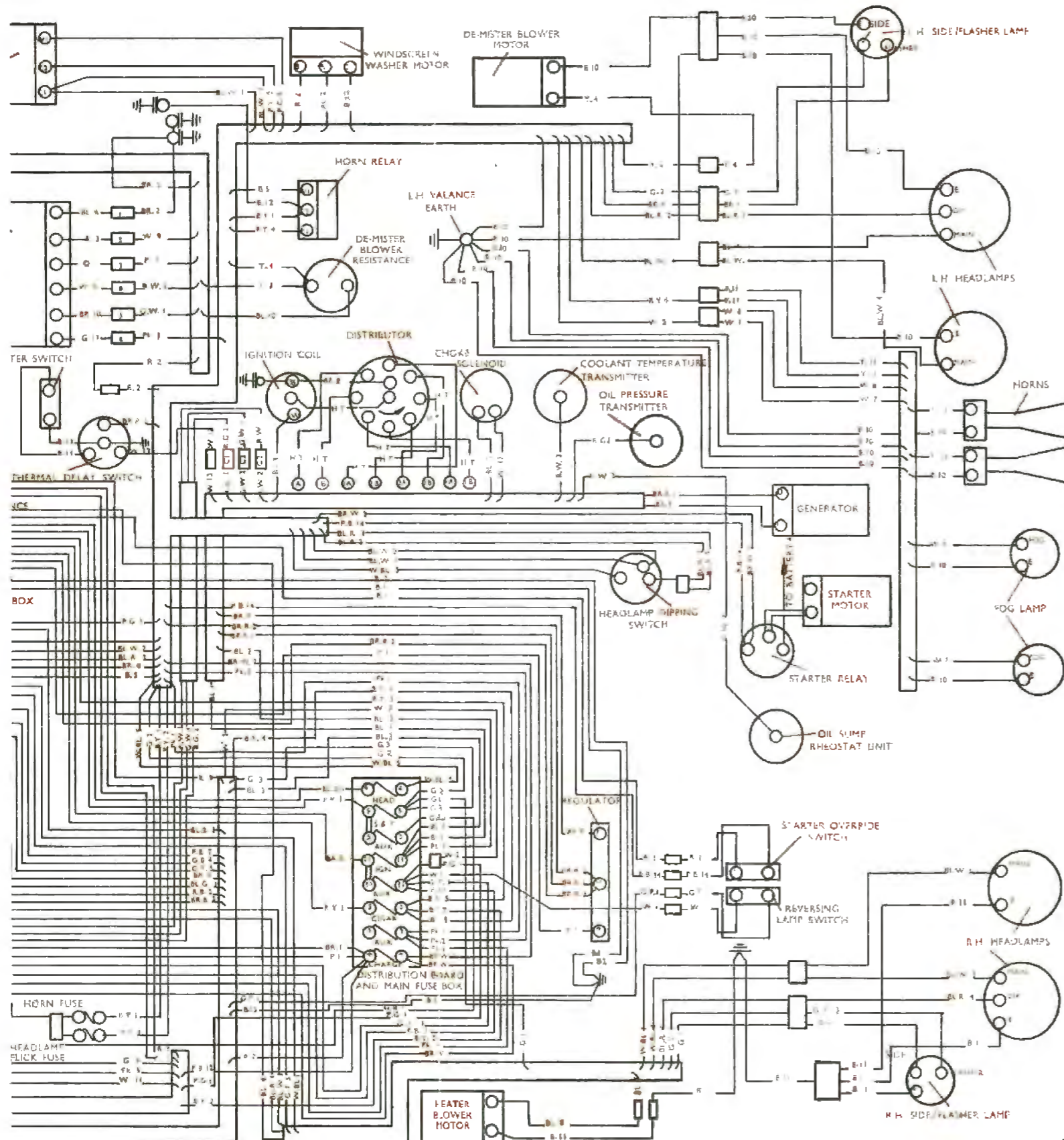

### KEY TO COLOUR CODING AND CONVENTIONAL SYMBOLS

R = RED W = WHITE Y = YELLOW G = GREEN B = BLACK  
 BL = BLUE BR = BROWN P = PURPLE PK = PINK O = ORANGE  
 These colours are often combined in pairs; e.g. P.Y. = PURPLE AND YELLOW B.B.R. = BROWN AND RED.

CODING		CODING	
CODING		CODING	
R.1	Switchbox 10	to	Starter Override Switch
R.2	Windscreen Washer Switch	to	Windscreen Washer Motor B
R.3	Windscreen Wiper Motor Connector 2	to	Windscreen Wiper Motor
R.4	LH Flasher Unit	to	Steering Column Connector Group
R.5	LH Flasher Unit	to	Bulkhead Connector C4
R.6	Bulkhead Connector C4	to	LH Stop Flasher Relay W1
R.7	Rear Compartment Ventilation Blower Resistance	to	Terminal Strip 15
R.8	Terminal Strip 15	to	Rear Compartment Ventilation Switch
R.9	Rear Compartment Ventilation Blower Resistance	to	Rear Compartment Ventilation Blower Motor
R.W.1	Coolant Temperature Indicator Connector C3	to	Connector C3
R.W.2	Windscreen Wiper Switch 2	to	Coolant Temperature Transmitter
R.W.3	Windscreen Wiper Motor Connector 4	to	Windscreen Wiper Motor Connector 4
R.Y.1	Distribution Board 3	to	Switchbox 3
R.Y.2	Switchbox 3	to	Radio Fuse
R.Y.3	Radio Fuse	to	Radio
R.Y.4	Horn Relay C1	to	LH Valve Connector Group
R.G.1	Oil Pressure Transmitter Connector C1	to	Connector C1
R.G.2	Oil Pressure Indicator	to	Oil Pressure Indicator
R.B.1	Fuel/Oil Level Switch	to	Junction Box 15
R.B.2	Junction Box 15	to	Fuel Tank Rheostat Unit T
W.1	Distribution Board 11	to	Reversing Lamp Switch
W.2	Distribution Board 11	to	Stop Lamp Switch
W.3	Switchbox 7	to	Hand Brake Switch
W.4	Junction Box 5	to	Junction Box 5
W.5	Junction Box 5	to	LH Valve Connector Group
W.6	LH Valve Connector Group	to	RH Fog Lamp
W.7	LH Valve Connector Group	to	RH Flasher Unit
W.8	Windscreen Wiper Motor Connector 4	to	Windscreen Wiper Motor
W.9	Windscreen Wiper Motor Connector 2	to	Windscreen Wiper Motor Connector 2
W.10	Division Glass Lift Switch (Facia)	to	Bulkhead Connector D3
W.11	Bulkhead Connector D3	to	Terminal Strip 18
W.12	Terminal Strip 18	to	Division Glass Lift Switch (Rear Compartment)
W.13	Thermal Delay Switch B	to	Choke Solenoid
W.B.1	RH Valve Connector Group	to	Junction Box 8
W.B.2	Junction Box 8	to	Headlamp Warning Lamp (Speedometer)
W.B.3	LH Roof Lamp Switches	to	LH Roof Lamp
W.B.4	LH Roof Lamp Connector	to	LH Roof Lamp and Switches
W.B.5	Headlamp Dipping Switch	to	Distribution Board 4
Y.1	Regulator B	to	Ammeter
Y.2	Ammeter	to	Switchbox 2
Y.3	De-mister Switch 2 (Facia)	to	De-mister Blower Resistance
Y.4	De-mister Blower Resistance	to	De-mister Blower Motor
Y.5	Heater Blower Resistance	to	Heater Switch 1 (Facia)
Y.6	Stop Lamp Switch	to	Stop Flasher Relays C2
Y.7	LH Stop Flasher Relay C3	to	LH Rear Lamp (Stop)
Y.8	RH Stop Flasher Relay C3	to	LH Rear Lamp (Stop)
Y.9	Heater Switch (Rear Compartment)	to	Heater Blower Resistance
Y.10	Heater Blower Resistance	to	Heater Blower Motor
Y.11	LH Valve Connector Group	to	Horns
G.1	Distribution Board 5	to	RH Side Lamp
G.2	Distribution Board 5	to	LH Side Lamp
G.3	Distribution Board 5	to	Terminal Strip 2
G.4	Terminal Strip 2	to	RH Rear Lamp (Tail)
G.5	Terminal Strip 2	to	Number Plate Lamp
G.6	Terminal Strip 2	to	LH Rear Lamp (Tail)
G.7	Instruments/Map Lamp Switch 5	to	Instruments Lamps
G.8	Division Glass Lift Switch (Facia)	to	Bulkhead Connector D1
G.9	Bulkhead Connector D1	to	Terminal Strip 16
G.10	Terminal Strip 16	to	Division Glass Lift Switch (Rear Compartment)
G.11	Windscreen Wiper Motor Connector 6	to	Windscreen Wiper Motor
G.W.1	Fuel/Oil Level Switch Connector C2	to	Connector C2
G.W.2	Windscreen Wiper Switch 1	to	Oil Sump Rheostat Unit
G.W.3	Windscreen Wiper Motor Connector 5	to	Windscreen Wiper Motor Connector 5
G.Y.1	Distribution Board 11	to	Flasher Switch
G.Y.2	RH Flasher Unit	to	Junction Box 9
G.Y.3	Junction Box 9	to	RH Side Flasher Lamp
G.Y.4	RH Flasher Unit	to	Junction Box 12
G.Y.5	Junction Box 12	to	Terminal Strip 1
G.Y.6	Terminal Strip 1	to	RH Rear Lamp (Flasher)
G.Y.7	Switchbox	to	Capping Rail Lamp
G.P.1	Reversing Lamp Switch	to	Terminal Strip 3
G.P.2	Terminal Strip 3	to	Reversing Lamp
G.P.3	Instruments/Map Lamp Switch 4	to	Map Lamp
G.B.1	Distribution Board 5	to	Switchbox 6
G.B.2	Switchbox 6	to	Instruments Lamps Switch 3
G.B.3	Fuel Filler Door Switch	to	Junction Box 11
G.B.4	Junction Box 11	to	Terminal Strip 6
G.B.5	Terminal Strip 6	to	Fuel Filler Door Solenoid
B.1	Charging Plug (-)	to	Regulator Earth
B.2	Regulator Earth	to	Instruments Panel Earth
B.3	Map Lamp, Capping Rail Lamp, Radio and Windscreen Wiper Switch 6	to	Instruments Panel Earth
B.4	Horn Button	to	Horn Relay W1
B.5	Junction Box 7	to	Hand Brake Warning Lamp
B.6	Hand Brake Warning Lamp	to	Steering Column Earth Point
B.7	Flasher Switch	to	Instrument Side Plate Earth
B.8	Number Plate Lamp, RH Rear Lamp, RH Companion Lamp and Roof Lamps	to	Body RH Earth
B.9	LH Rear Lamp, LH Companion Lamp and Fuel Filler Door Solenoid	to	Body LH Earth
B.10	Horns, Fog Lamps, LH Side Flasher Lamp, LH Headlamps, Windscreen Washer Motor C and De-mister Blower Motor	to	Body LH Earth
B.11	Heater Blower Motor, RH Side Flasher Lamp and RH Headlamps	to	RH Valve Earth
B.12	Horn Relay C2	to	Condenser
B.13	Earth on Thermal Delay Switch	to	Earth on Thermal Delay Switch
B.14	Stop Switch	to	Thermal Delay Switch
B.15	Ventilation Blower Motor (Rear Compartment)	to	Regulator Earth

CODING		CODING	
CODING		CODING	
B.W.1	Switchbox 8	to	Horn Fuse Connector
B.Y.1	Horn Fuse	to	Horn Relay C2
B.Y.2	Distribution Board 3	to	Terminal Strip 12
B.Y.3	Terminal Strip 12	to	Cigar Lighter (Rear Compartment)
B.Y.4	Distribution Board 3	to	Terminal Strip 4
B.Y.5	Distribution Board 3	to	Cigar Lighter (Facia)
BL.1	Distribution Board 11	to	Ignition Coil (S.W.)
BL.2	Distribution Board 11	to	Choke Solenoid
BL.3	Distribution Board 11	to	Fuel Pumps
BL.4	Fuel/Oil Level Indicator	to	Fuel Warning Lamp
BL.5	Switchbox 3	to	Generator Warning Lamp
BL.6	Windscreen Wiper Motor Connector 1	to	Windscreen Wiper Motor
BL.7	Heater Switch 2 (Facia)	to	Heater Blower Motor Resistance
BL.8	Heater Blower Resistance	to	Heater Blower Motor
BL.9	Heater Switch (Rear Compartment)	to	Heater Blower Motor Resistance
BL.10	De-mister Switch	to	De-mister Blower Motor Resistance
BL.R.1	Distribution Board 4	to	Switchbox 4
BL.R.2	Headlamp Dipping Switch	to	LH Headlamp (Dip)
BL.R.3	Headlamp Dipping Switch	to	Junction Box 17
BL.R.4	Junction Box 17	to	LH Headlamp (Dip)
BL.W.1	Headlamp Dipping Switch	to	Headlamp Flick Relay C1
BL.W.2	Headlamp Dipping Switch	to	Junction Box 18
BL.W.3	Junction Box 18	to	RH Headlamps (Main)
BL.W.4	Headlamp Flick Relay C1	to	LH Headlamps (Main)
BL.G.1	Fuel Tank Rheostat Unit W	to	Junction Box 14
BL.G.2	Junction Box 14	to	Fuel Warning Lamp
BL.B.1	LH Flasher Unit	to	LH Flasher Warning Lamp (Speedometer)
BL.B.2	Hand Brake Switch	to	Junction Box 4
BL.B.3	Junction Box 4	to	Hand Brake Warning Lamp
BR.1	Distribution Board (-)	to	Charging Plug (-)
BR.2	Windscreen Wiper Switch 5	to	Windscreen Wiper Motor Connector 1
BR.3	LH Flasher Unit	to	Junction Box 6
BR.4	Junction Box 6	to	LH Side Flasher Lamp
BR.5	LH Flasher Unit	to	Junction Box 13
BR.6	Junction Box 13	to	Terminal Strip 5
BR.7	Terminal Strip 5	to	LH Rear Lamp (Flasher)
BR.8	Ignition Coil (C.B.)	to	Distributor Contact Breaker
BR.9	Generator F	to	Regulator F
BR.10	Windscreen Wiper Motor Connector 5	to	Windscreen Wiper Motor
BR.R.1	Generator D	to	Regulator D
BR.R.2	Regulator D	to	Thermal Delay Switch
BR.R.3	Regulator D	to	Generator Warning Lamp
BR.R.4	Switchbox 11	to	Distribution Board 11
BR.W.1	Distribution Board (-)	to	Ammeter
BR.W.2	Distribution Board (1)	to	Scarcor Relay
BR.W.3	Switchbox (1)	to	Switchbox (1)
BR.B.1	Fuel/Oil Level Switch	to	Fuel/Oil Level Indicator
BR.B.2	Damper Switch	to	Junction Box 16
BR.B.3	Junction Box 16	to	Damper Solenoids
P.1	Distribution Board (-)	to	Clock
P.2	Distribution Board (-)	to	Terminal Strip 7
P.3	Terminal Strip 7	to	Luggage Boot Lamp
P.4	Terminal Strip 7	to	RH Companion Switch
P.5	Terminal Strip 7	to	RH Companion Switch
P.6	RH Companion Switch	to	Rear Window Solenoid
P.7	Windscreen Wiper Switch 3	to	Windscreen Wiper Motor Connector 3
P.8	RH Flasher Unit	to	Bulkhead Connector C5
P.9	Bulkhead Connector C5	to	RH Stop Flasher Relay W1
P.10	RH Flasher Unit	to	Flasher Switch
P.11	Ventilation Blower Motor Resistance (Rear Compartment)	to	Terminal Strip 14
P.12	Terminal Strip 14	to	Ventilation Switch (Rear Compartment)
P.Y.1	Distribution Board 5	to	Switchbox 5
P.Y.2	Headlamp Flick Fuse	to	Headlamp Flick Relay C2
P.G.1	Distribution Board 11	to	Terminal Strip 13
P.G.2	Terminal Strip 13	to	Heater Switch (Rear Compartment)
P.G.3	Terminal Strip 13	to	Ventilation Switch (Rear Compartment)
P.G.4	Flasher Switch	to	Junction Box 3
P.G.5	Junction Box 3	to	Headlamp Flick Relay W1
P.G.6	Damper Switch	to	Steering Column Connector Group
P.G.7	Rear Window De-mister Switch	to	Steering Column Connector Group
P.G.8	Steering Column Connector Group	to	Oil Pressure Indicator
P.G.9	RH Flasher Unit	to	RH Flasher Warning Lamp (Speedometer)
P.B.1	Distribution Board 11	to	Fuel/Oil Level Indicator
P.B.2	Fuel/Oil Level Indicator	to	Oil Pressure Indicator
P.B.3	Oil Pressure Indicator	to	Coolant Temperature Indicator
P.B.4	Coolant Temperature Indicator	to	De-mister Switch 3 (Facia)
P.B.5	Coolant Temperature Indicator	to	Heater Switch 3 (Facia)
P.B.6	Rear Window De-mister Switch	to	Junction Box 10
P.B.7	Junction Box 10	to	Terminal Strip 8
P.B.8	Terminal Strip 8	to	Rear Window De-mister
P.B.9	Terminal Strip 8	to	RH Companion Lamp
P.B.10	RH Companion Lamp Switch	to	LH Companion Lamps
P.B.11	Distribution Board (-)	to	Terminal Strip 11
P.B.12	Terminal Strip 11	to	Feed for Division Glass Lift Mechanism
P.B.13	Terminal Strip 11	to	Starter Relay
P.B.14	Starter Override Switch	to	Starter Relay
PK.1	Distribution Board 3	to	Windscreen Wiper Motor Connector 6
PK.2	Distribution Board 3	to	Windscreen Washer Motor A
PK.3	Distribution Board 3	to	Fuel Filler Door Switch
PK.4	Division Glass Lift Switch (Facia)	to	Bulkhead Connector D2
PK.5	Bulkhead Connector D2	to	Terminal Strip 17
PK.6	Terminal Strip 17	to	Division Glass Lift Switch (Rear Compartment)
Ph.1	Flasher Switch	to	Steering Column Connector Group
O.1	Windscreen Wiper Motor Connector 3	to	Windscreen Wiper Motor

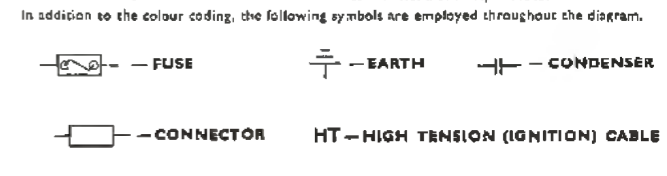

# SUPPLEMENTARY WIRING DIAGRAM

**ROLLS-ROYCE PHANTOM V**  
**Chassis No. 5.VD.93 onwards**

This wiring diagram should be read in conjunction with wiring diagram T.S.D. Publication 2123 and shows the additional wiring and alteration to wiring required for cars fitted with the hazard warning system and electrically operated actuators for the heating, demisting and ventilation system.

© Rolls-Royce Limited (1967)

Rolls-Royce policy is one of continuous engineering improvement and the right is reserved to revise the contents of this publication without prior notice.

