



**Rolls-Royce
Silver Cloud II
and Bentley S2**



**Air Conditioning System
Manual**



AIR CONDITIONING (REFRIGERATION)



PREFACE

The primary purpose of this Manual is to provide the refrigeration engineer with information necessary to enable him to service and maintain the Rolls-Royce Refrigeration System. The Manual will also be of great assistance to the motor car engineer wishing to familiarise himself with the function and position of the various components.

Contained herein is a description of the system and comprehensive instructions for the maintenance, dismantling and assembly of each unit, together with the necessary service procedure. All special tools required to carry out service operations are listed and illustrated.

Although all information provided within the Manual was correct when going to print, additions or modifications may subsequently be necessary. These will be brought to the notice of the reader by means of Service Bulletins, and it is recommended that a note be made in the appropriate Section of the Manual, referring to the latest Bulletin.

Advice and assistance regarding maintenance and servicing problems will always be available on application to the Service Department at Pym's Lane, Crewe; all such enquiries should be accompanied by the chassis number of the car.

AIR CONDITIONING

REFRIGERATION

UNDERWING UNIT

INTRODUCTION

The underwing air conditioning system fitted to Standard Steel Saloon Rolls-Royce Silver Cloud II and Bentley S.2 motor cars provides de-misting, de-frosting, car heating and ventilation. Alternatively, a comprehensive underwing refrigeration system, providing a wide range of heating and cooling conditions, can be installed at the customer's request.

Whilst servicing of the standard heating and de-misting system may be undertaken with confidence by the normal service engineer, it must be appreciated that correct maintenance of the refrigeration system will be better effected by a specialised refrigeration engineer.

Special equipment and precautions are necessary when undertaking servicing and overhaul operations and it should be always remembered that the refrigerant circulation system is sealed and pressurised. Thus joints should not be disturbed unnecessarily as the system must be discharged prior to breaking any joint, unless this is protected by service valves.

The Refrigeration System, although an optional extra, is in fact not an isolated unit, but a large system carefully integrated into the design of the motor car. The electrical wiring, in most cases, is combined in the main wiring looms and the individual mechanical and electro-mechanical control units have been installed in positions promoting simplicity of operation and the facilitation of servicing.

All enquiries should be addressed to:—

ROLLS-ROYCE LIMITED

Pym's Lane

Crewe

Cheshire

Telephone:

Crewe 55155

Telegrams:

"ROYCRU, CREWE"

T.S.D. Publication 723

Printed in England

CONTENTS

DESCRIPTION	SECTION C.1
OPERATING THE SYSTEM	SECTION C.2
ELECTRICAL COMPONENTS	SECTION C.3
COMPRESSOR, CONTROL VALVES AND ANCILLARY UNITS	SECTION C.4
MAINTENANCE	SECTION C.5
SERVICING	SECTION C.6

INDEX

Description	1		
Operating the system	5	To remove and fit	16
Electrical components		Receiver	18
Actuators	9	Maintenance	
To adjust	10	Schedules	21
Blower motors	13	Every 2,500 miles	21
Evaporator change-over relay	12	Every 5,000 miles	21
Lower airstream switch	8	Every 10,000 miles or annually	21
Magnetic clutch — compressor	11	Servicing	
Rear window de-mister relay	12	Charging the system	28
Resistances — blower motors	13	Checking for leaks	29
Solenoid valves	11	Discharging the refrigerant	26
Thermostatic switches	9	Evacuating the system	27
Upper airstream switch	7	Fault diagnosis	23
The compressor, control valves and ancillary units		Air delivery	24
Compressor	15	Fault location	24
Fault diagnosis	15	Pressure tests	26
Lubricant	17	Refrigerant circulation	24
Oil level — to check	17	Superheat test	26
Shaft seal — to replace	17	Importance of chemical stability	23
To purge the air	18	Sealing of components	23
To remove and fit	15	Precautions to be observed	23
Condenser	18	Exposure to refrigerant	23
Drier	19	First-aid treatment	23
Expansion valves	19	Right-hand front wing — to remove	29
Flow control valve	20	Special tools required	23
Magnetic clutch	15	Sweeping the system	27
		Underwing unit — to remove	30
		To fit	30

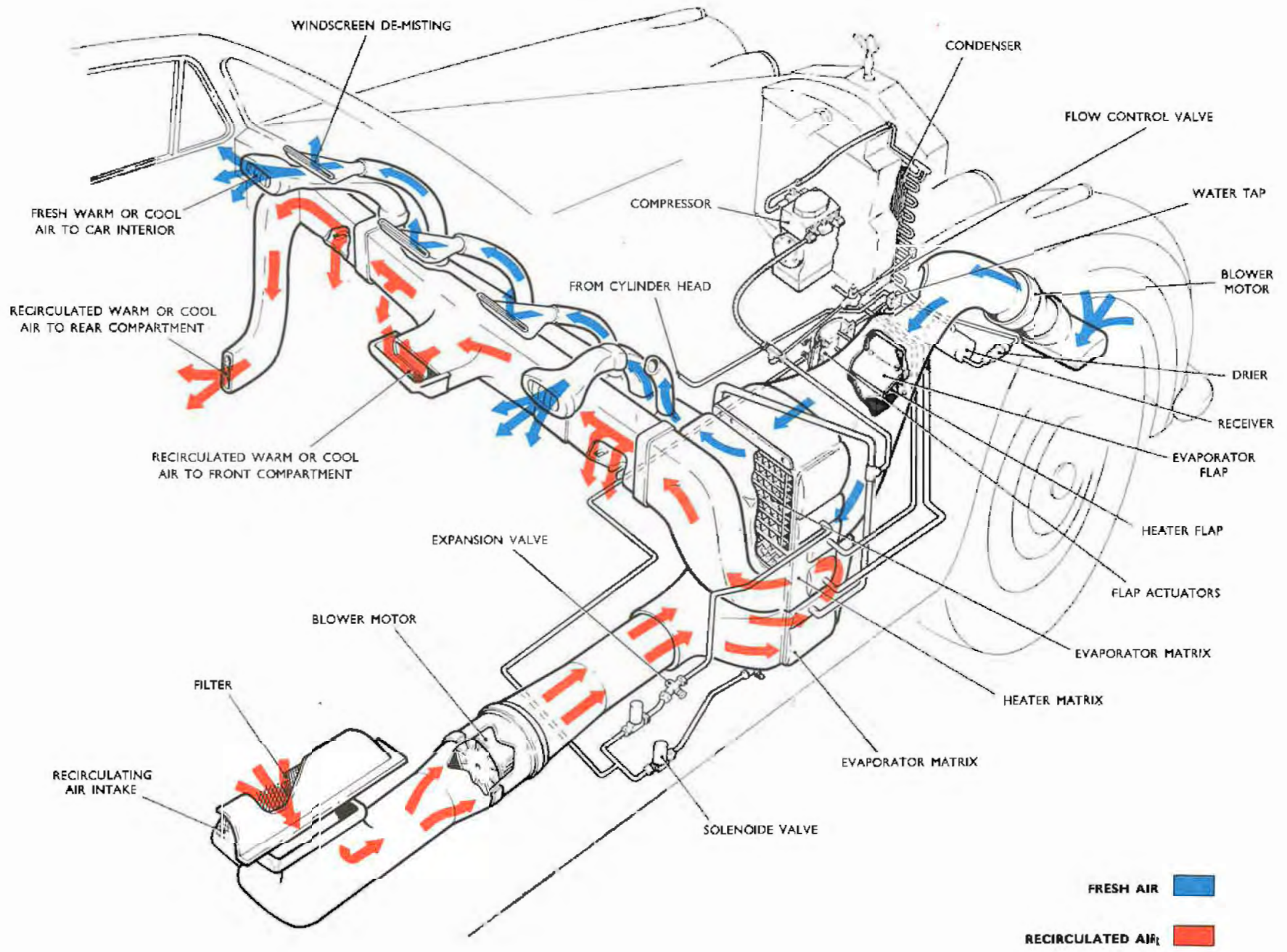

Fig. 1 The air conditioning system

SECTION C.1

DESCRIPTION

The function of the Rolls-Royce Air Conditioning Unit is to maintain the car interior temperature and humidity at a comfortable level in all climatic conditions.

The unit is divided into two parts — the fresh air system, and the recirculatory system; these

may be operated independently or together in order to produce the desired condition. The fresh air system introduces heated, cooled or ambient temperature air into the car interior; the recirculatory system draws air from the car interior, conditions it, and re-introduces it.

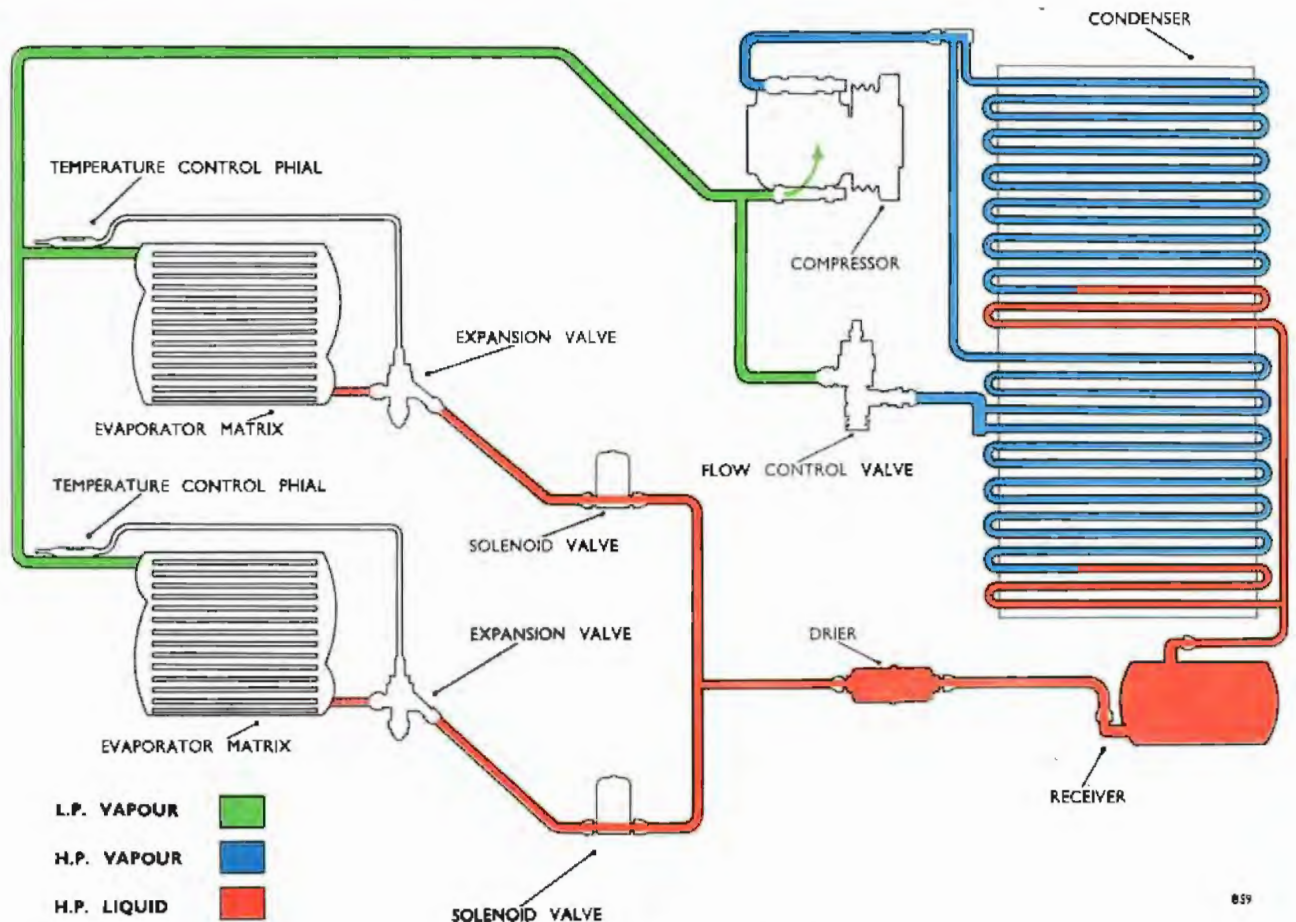

Fig. 2 Diagram of refrigerant circulation

T.S.D. 723/B1907

The main advantage of this feature is that although recirculation enables the air conditioning system to operate more effectively, the simultaneous introduction of fresh air provides adequate ventilation, permitting the car to be driven with the windows closed.

In countries where humidity is high, the unit will extract a large proportion of moisture from the air; if necessary, the heater may be used in conjunction with the refrigeration system to provide warm, dry air when the atmosphere is cool and damp.

Fine gauze filters incorporated in the recirculation and fresh air intakes (see Fig. 1), prevent the ingress of grit and other foreign particles.

The refrigeration system operates on a cyclic principle: after being compressed in the compressor, the refrigerant passes to a condenser and then in liquid form to a valve where it expands and then evaporates in a matrix before returning to the compressor.

During evaporation, the gas absorbs heat from the air passing over the matrix surface. The air thus enters the car at a reduced temperature, also at reduced humidity, since a proportion of the water vapour in the air will condense during the cooling process and drain away through drain holes provided.

The system is charged with Freon 12 refrigerant (Dichlorodifluoromethane) circulated by the compressor. The compressor is driven via a magnetic clutch by Vee belts from the coolant pump pulley.

The compressor delivers refrigerant to the condenser mounted in front of the engine radiator matrix, where the gas is condensed to liquid.

A series of pipes incorporating receiver, drier, solenoid valves and expansion valves connects the condenser to the evaporator units.



- 1 HIGH PRESSURE SERVICE VALVE
- 2 LOW PRESSURE SERVICE VALVE
- 3 COMPRESSOR OIL FILLER PLUG

IMPORTANT: Refer to compressor details for instructions regarding the removal of this plug.

Fig. 3 Compressor in position

The refrigerant is atomised in the expansion valves before entering the evaporators, where the resultant pressure drop permits the liquid to vaporise and so absorb heat from the air passing through the matrices.

Air is ducted to the evaporators by two systems:

From the air intake situated at the front of the right-hand wing, fresh air is ducted along inside

the wing and boosted, by means of a blower motor, through the upper evaporator matrix and/or the top half of the heater matrix. The air is delivered into the saloon through the capping rail adjustable outlets and the windscreen de-misting slots.

The recirculating air is ducted from the air intake, situated behind the right-hand front seat, and boosted, by means of a blower motor, through the lower evaporator matrix and the lower half of the heater matrix. It then enters the saloon via the cross duct under the fascia, the adjustable duct under the front picnic tray, and the duct on the left-hand side of the scuttle.

To prevent the temperature of the air passing through the evaporator falling below freezing point and the system becoming blocked by the formation of ice, a thermostatic switch is fitted to each matrix and is used in conjunction with the solenoid valves to control the flow of refrigerant. If both solenoid valves are closed, the refrigerant is by-passed from the condenser back to the compressor through the flow control valve. The control valve is adjusted to maintain a minimum pressure of 2 lb./sq. in. in the low pressure side of the system. The thermostatic switches control the minimum temperature of the evaporators and must not be set below 2°C., otherwise icing may occur.

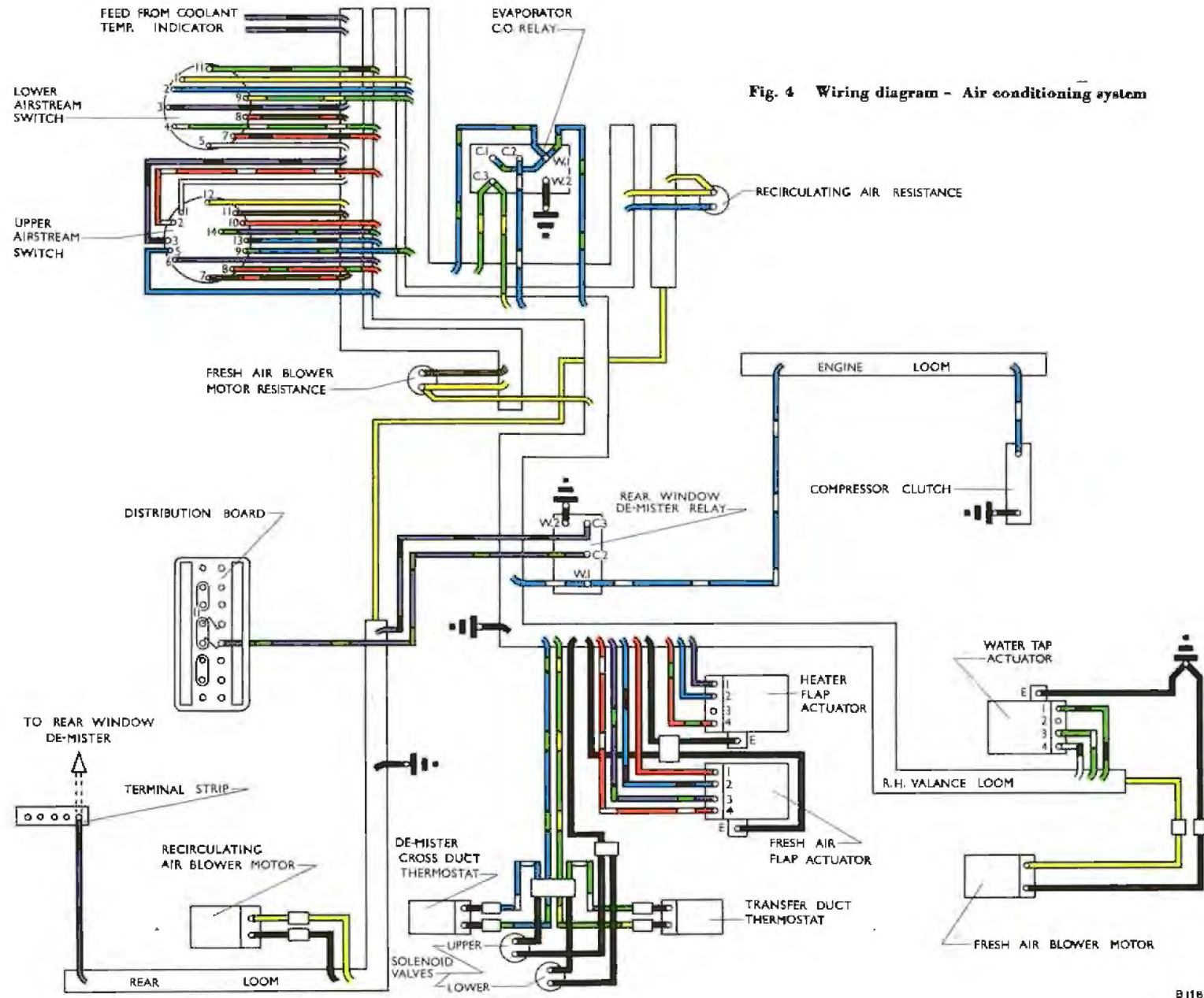

Fig. 4 Wiring diagram - Air conditioning system

B116

SECTION C.2

OPERATING THE SYSTEM

The system is controlled by two switches mounted on the facia board and marked 'UPPER' and 'LOWER'.

The 'UPPER' switch controls the fresh air system and regulates the air entering the saloon from the adjustable vents on either side of the capping rail and from the windscreen de-misting slots. This switch has seven positions — four positions clockwise which control the heating system, and three positions anti-clockwise which control the refrigeration.

To obtain the desired condition when operating the refrigeration, the switch must be rotated anti-clockwise.

In the first position the evaporator flap will be fully open and the heater flap fully closed; the water tap will be closed and the blower motor operating at medium speed. This results in normal ambient air entering the saloon.

In the second position both the evaporator flap and the heater flap will be fully open; the water tap will be closed, the compressor operating and the blower motor running at medium speed. The result is a mixture of ambient and refrigerated air passing from the top half of the heater matrix and the upper evaporator unit.

In the third position the evaporator flap will be fully open, the heater flap will be fully closed, the water tap will be closed, the compressor operating and the blower motor at medium speed. This results in cold air entering the saloon via the upper evaporator.

If the knob of the 'UPPER' switch is pulled out whilst turned to any of its positions, the blower motor operates at full speed.

The 'LOWER' switch controls the recirculating system and has five positions. Three positions clockwise control the heating system and the two positions anti-clockwise control the refrigeration system.

In the first position anti-clockwise the water tap will be closed, the compressor operating and the blower motor at medium speed. This results in cold recirculated air entering the saloon via the lower evaporator.

In the second position anti-clockwise the water tap will be closed, the compressor operating and the blower motor at full speed. This results in recirculated air of minimum temperature entering the saloon.

SECTION C.3

ELECTRICAL COMPONENTS

UPPER AIRSTREAM SWITCH

This switch controls the heater and evaporator flap actuators, the fresh air blower motor, the compressor clutch and the water tap actuator.

The switch utilises eight angular positions — the vertical or OFF position, four positions clockwise and three positions anti-clockwise.

In all seven operating positions, with the switch knob 'in', the fresh air blower motor operates at medium speed.

When the switch knob is pulled outwards, all seven conditions are duplicated but with the blower motor operating at full speed. This is achieved by the provision of a contact sleeve at the end of the switch spindle. This sleeve connects two fixed contacts when the knob is pulled outwards, thereby completing a new circuit by-passing the resistance.

The main switch mechanism consists basically of five sets of moving contacts which rotate when the control knob is turned. Lobes on these contact plates 'make' and 'break' with eleven sets of fixed contacts spaced around the arc of travel of the contact lobes.

A numbered disc is attached to the rear of the switch for terminal identification, the key to which is as follows:—

Terminal Number

1	Water Tap 'Leak'.
2	Evaporator Flap Closed.
3	Supply.
5	Heater Flap $\frac{3}{4}$ Open.
6	Heater Flap Fully Open.
7	Water Tap Closed.
8	Heater Flap Closed.
9	Compressor Clutch 'In'.
10	Evaporator Flap Fully Open.
11	Blower Motor Medium Speed.
12	Blower Motor Full Speed.
13	Evaporator Flap $\frac{2}{3}$ Open.
14	Evaporator Flap $\frac{1}{3}$ Open.

Switch positions

1st clockwise

Evaporator Flap	..	FULLY OPEN
Heater Flap	..	CLOSED
Water Tap	..	LEAK POSITION
Blower Motor	..	MEDIUM SPEED

Providing Normal ambient air flow at Medium Speed. (Heater Matrix warming in readiness for 2nd position.)

2nd clockwise

Evaporator Flap	..	$\frac{3}{4}$ OPEN
Heater Flap	..	$\frac{3}{4}$ OPEN
Water Tap	..	LEAK POSITION
Blower Motor	..	MEDIUM SPEED

Providing Mixed flow of ambient and warm air.

3rd clockwise

Evaporator Flap	..	$\frac{1}{2}$ OPEN
Heater Flap	..	$\frac{1}{2}$ OPEN
Water Tap	..	LEAK POSITION
Blower Motor	..	MEDIUM SPEED

Providing As above, but air of increased temperature entering the car.

4th clockwise

Evaporator Flap	..	CLOSED
Heater Flap	..	FULLY OPEN
Water Tap	..	LEAK POSITION
Blower Motor	..	MEDIUM SPEED

Providing Maximum air temperature permitted by coolant leak.

N.B. Knob pulled fully out in any position — blower motor operates at FULL SPEED.

1st anti-clockwise

- Evaporator Flap .. FULLY OPEN
- Heater Flap .. CLOSED
- Water Tap CLOSED
- Blower Motor .. MEDIUM SPEED

Providing Air of ambient temperature entering the car.

2nd anti-clockwise

- Evaporator Flap .. FULLY OPEN
- Heater Flap .. FULLY OPEN
- Water Tap CLOSED
- Compressor .. OPERATING
- Blower Motor .. MEDIUM SPEED

Providing Ambient and cold air flow via the upper heater and upper evaporator matrices.

3rd anti-clockwise

- Evaporator Flap .. FULLY OPEN
- Heater Flap .. CLOSED
- Water Tap CLOSED
- Compressor .. OPERATING
- Blower Motor .. MEDIUM SPEED

Providing Air of minimum temperature entering the car via the upper evaporator matrix.

N.B. If the switch knob is pulled out, the blower motor operates at FULL SPEED.

LOWER AIRSTREAM SWITCH

This switch controls the recirculatory blower motor, the water tap actuator and the compressor clutch.

Six positions are utilised — the vertical or OFF position, three positions clockwise and two positions anti-clockwise.

The construction and operation of the mechanism is similar to that of the upper airstream switch except that no 'pull-out' mechanism

is provided for blower motor full speed — full speed is only obtained in position three clockwise and position two anti-clockwise.

Lobes on four sets of moving contacts complete circuits with combinations of the nine sets of fixed contacts.

A numbered disc is attached to the rear of the switch to assist terminal identification; the key to these numbers is as follows: —

Terminal Number

- 1 Recirculation Blower Motor Full Speed.
- 2 Recirculation Blower Motor Medium Speed.
- 3 Supply.
- 4 Water Tap 'Leak'.
- 5 Supply from Upper Airstream Switch No. 1 Terminal.
- 7 Water Tap Closed.
- 8 Supply from Upper Airstream Switch No. 7 Terminal.
- 9 Compressor Clutch 'In'.
- 11 Water Tap Open.

Note: The system will not provide warm fresh air and cold recirculated air simultaneously.

If the lower airstream switch is in a 'cold' position (anti-clockwise) the water tap remains closed for all positions of the upper airstream switch, either clockwise or anti-clockwise.

If the lower airstream switch is 'off' or in position 1 clockwise, the upper airstream switch selects water tap leak for all clockwise positions.

If the lower airstream switch is in positions 2 or 3 clockwise, the upper airstream switch selects water tap open for all clockwise positions.

Switch positions

1st clockwise

- Water Tap LEAK POSITION
- Blower Motor .. MEDIUM SPEED

Providing Warm recirculated air.

2nd clockwise

- Water Tap OPEN
- Blower Motor .. MEDIUM SPEED

Providing Recirculated air of increased temperature.

3rd clockwise

Water Tap OPEN
Blower Motor .. FULL SPEED

Providing Recirculated air of maximum temperature.

1st anti-clockwise

Water Tap CLOSED
Compressor .. OPERATING
Blower Motor .. MEDIUM SPEED

Providing Cold recirculated air entering the car via the lower evaporator matrix.

2nd anti-clockwise

Water Tap CLOSED
Compressor .. OPERATING
Blower Motor .. FULL SPEED

Providing Recirculated air of minimum temperature entering the car via the lower evaporator matrix.

THERMOSTATIC SWITCHES

The Cartridge Thermostat consists of two silver contacts attached to, but insulated from, two special nickel steel members of low expansion coefficient, mounted under tension in a seamless drawn brass tubular shell.

Changes in temperature cause the shell to expand or contract, subjecting the steel contact supports to changes of tension, thereby causing the contacts to 'make' or 'break'.

Two thermostats are incorporated in the system, each controlling one of the solenoid valves which regulate the supply of refrigerant to the evaporator matrices. When the temperature of the air leaving the matrices falls to a level a little above freezing point, the flow of refrigerant is cut off, in order to prevent the matrices becoming blocked by ice formation.

Adjustment of the cut-off point is effected by varying the tension in the nickel steel members by means of a vernier screw which is accessible when the thermostat rubber end cover is removed (see Fig. 5).

Setting the switch should be attempted only with the aid of a power source and indicator light. Random operation of the setting screw, without positive indication of the 'make' or 'break' of the contacts, may strain the internal assembly.

A locking clamp is provided to ensure that the setting remains undisturbed by vibrations, and should be adjusted so that the vernier screw may be turned without undue strain; this should be carried out *before* final adjustment of the switch, since tightening of the locking screw after adjustment may alter the setting.

Care should be exercised in handling the thermostat, since it is the outside shell which forms the operating element and distortion of this shell may affect the operation.

ACTUATORS

The heater flap, evaporator flap and heater water tap actuators are identical units, consisting of a small electric motor driving through a reduction gear train. The shaft carrying the final gear in the train also carries a contact disc which has a portion removed; this disc conveys current to the motor via any one of four fixed contacts, when the circuit is completed by the upper or lower airstream switch action.

Operation of the motor causes the disc to rotate until the gap in the disc reaches the contact, thus breaking the circuit.

Attached to the end of each actuator gear shaft is a crank lever. These crank levers are connected by links to similar levers fixed to the water tap spindle and to extensions of the heater and evaporator flap spindles. The extension spindles protrude through the actuator mounting platform, and flexible couplings transmit the drive, through holes in the valance, to the flap spindles. Rubber sleeves are provided under the wing to protect the flap driving mechanism.



Fig. 5 Thermostatic switch

The water tap actuator is situated low down at the forward end of the right-hand valance (see Fig. 6). The heater and evaporator flap actuators are mounted together on a single platform midway along the valance, adjacent to the forward brake fluid reservoir (see Fig. 7).

Actuators — to adjust

Whenever the underwing unit or the wing has been removed, it will be necessary to check and possibly adjust the actuator setting. This should be carried out after the wing has been refitted.

The procedure to be adopted is as follows, noting that instructions 2, 3 and 4 do not apply if the wing only has been removed:—

1. Slacken the four bolts which clamp the crank levers to the extension spindles and gear shafts, also slacken the two Allen grub screws securing the collars to the extension spindles.
2. Remove the single nut and washer securing the forward end of the mounting platform to the valance and slacken the two rear securing nuts.
3. Move the forward end of the mounting platform away from the valance and insert the two coupling tubes through the valance

holes, locating them on the driving dogs on the flap spindles.

4. Insert the extension spindle dogs into the slots in the coupling tubes and secure the mounting platform to the valance.
5. Push the extension spindles fully into the coupling tubes and tighten the two crank lever clamping bolts on to the extension spindles.
6. Slowly withdraw the extension spindles about $\frac{1}{8}$ in. and tighten the Allen grub screws to lock the collars against the end faces of the bearing tubes.
7. Detach the two crank levers from the gear shafts and rotate the extension spindles by means of their crank arms. The spindles should be free to rotate through 90° . Movement through a larger angle indicates that the coupling tubes are not engaged with the dogs on the spindles and this should be rectified.
8. Ensure that the upper and lower airstream switches are in the OFF position. Switch on the ignition for approximately 30 seconds to allow the actuator motors to

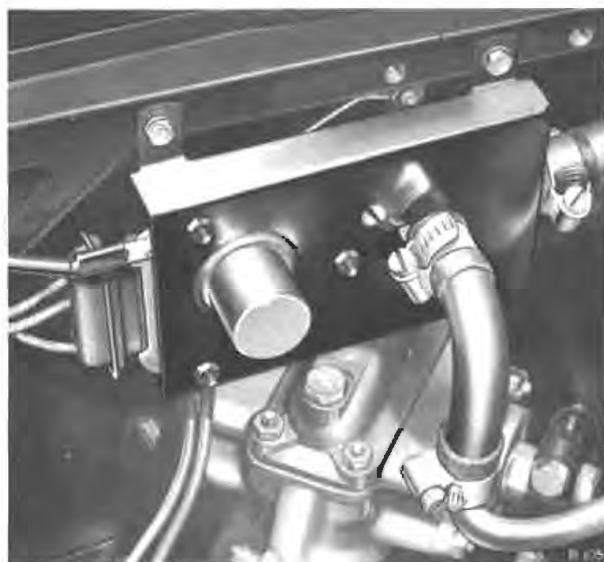

Fig. 6 Water tap and actuator

rotate to the fully closed position. It will then be necessary to adjust the two actuators separately as follows:—

Evaporator flap actuator

1. Rotate the extension spindle anti-clockwise (when viewed over the left-hand wing) until resistance is encountered.
2. Slightly slacken the crank lever clamping bolt and rotate the crank lever until it slopes forward and upward at 45°.
3. Place the gear shaft crank lever loosely in position on the gear shaft.
4. Adjust the position of the extension crank so that when the gear shaft crank is rotated clockwise on the shaft, resistance is encountered for a few degrees to each side of the fully rearward position. (This indicates that the flap is being pressed tightly into its fully closed position). Tighten the clamping bolt to lock the extension spindle crank.
5. Rotate the gear shaft crank to the fully rearward end of its stroke (i.e. when the gear shaft crank and the connecting link are parallel) then tighten the clamping bolt.

Heater flap actuator

1. Rotate the extension spindle clockwise (when viewed over the left-hand wing) until resistance is encountered.
2. Slightly slacken the crank lever clamping bolt and rotate the crank lever until it slopes 60° forward of the vertical downward position.
3. Place the gear shaft crank lever loosely in position on the gear shaft.
4. Adjust the position of the extension spindle crank so that when the gear shaft crank is rotated clockwise on the shaft, resistance is encountered for a few degrees to each side of the fully rearward position.

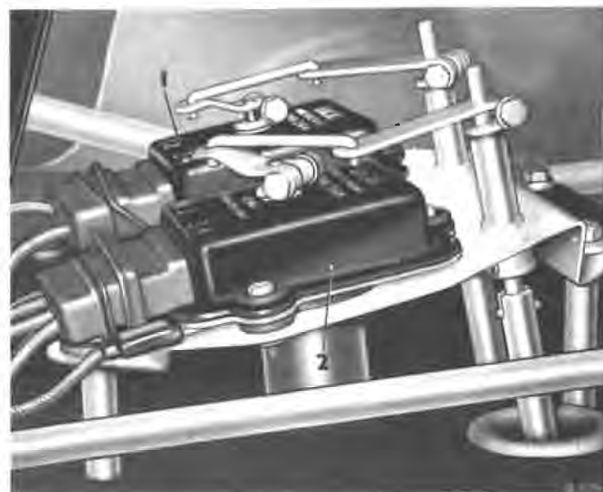

1 HEATER FLAP ACTUATOR
2 EVAPORATOR FLAP ACTUATOR

Fig. 7 Flap actuators

Tighten the clamping bolt to lock the extension spindle crank.

5. Rotate the gear shaft crank to the fully rearward end of its stroke (i.e. when the gear shaft crank and the connecting link are parallel), then tighten the clamping bolt.

Operate the switches and visually check that the actuators are functioning correctly.

MAGNETIC CLUTCH — COMPRESSOR

See Page 15 for description and procedure.

SOLENOID VALVES

Model . . Danfoss EVJD-6 (Stamped 'F' on the valve body).

The solenoid valves control the flow of refrigerant to the expansion valves which serve the two evaporator matrices.

The lower end of the moving core has a rubber insert which seats against a nozzle protruding upwards from the body of the valve. When the circuit is open, the core seat is held against the nozzle by a spring-loaded plunger which is situated in the core so as to extend from the upper face and contact the blind end of the solenoid bore (see Fig. 8).



- 1 RETAINING SCREW
- 2 IDENTIFICATION PLATE
- 3 SOLENOID AND CASING
- 4 VALVE CHAMBER COVER
- 5 SECURING SCREWS
- 6 MOVING CORE
- 7 DIAPHRAGM AND NOZZLE
- 8 SEALING RING
- 9 VALVE BODY

Fig. 8 Solenoid valve — exploded view

When the coil is energised, the core is drawn upwards and the refrigerant flows through two small holes in the rubber diaphragm which mounts the nozzle, leaving via the nozzle orifice.

Since the total area of the two inlet holes in the diaphragm is less than the area of the nozzle

orifice, the resultant pressure drop in the chamber causes the diaphragm to lift from its seating, allowing the refrigerant to flow from the annular inlet groove, under the diaphragm, to the outlet port, thus by-passing the two inlet holes and the nozzle orifice and permitting full flow.

A leak from the valve casing will probably be due to inefficient sealing; renew the rubber 'O' ring between the valve body and the valve chamber cover, refit the cover and tighten the six retaining screws.

A leaking valve may be caused either by a faulty diaphragm or a damaged core rubber insert.

Icing of the evaporator may be caused by a leaking valve or incorrect operation due to a faulty or wrongly set thermostat.

THE REAR WINDOW DE-MISTER RELAY

In order to prevent heavy loading of the battery, resulting from the refrigeration system and the rear window de-mister unit working in opposition, a relay is incorporated in the system to break the circuit for the rear window de-mister whenever refrigerated air is being passed into the car, i.e. upper airstream switch — positions 2 and 3 anti-clockwise; lower airstream switch — positions 1 and 2 anti-clockwise.

The relay is mounted on the upper right-hand side of the bulkhead.

THE EVAPORATOR CHANGE-OVER RELAY

The leads from the number nine terminals of the upper and lower airstream switches leave the left-hand valance loom and enter the W1 and C3 terminals of the change-over relay mounted at the centre of the bulkhead. From these terminals, leads pass through the right-hand valance loom to the cross duct and transfer duct thermostats which control the solenoid valves. From the C2 terminal a lead feeds the compressor clutch via the rear window de-mister relay.

The purpose of the change-over relay is to provide a feed to the compressor clutch from



B 103

Fig. 9 Blower motor — exploded view

either of the independently operated airstream switches.

The C3 and C2 contacts are normally closed, allowing a feed when the lower switch is turned to an anti-clockwise position. Operation of the upper switch to a 'cool' position energises the winding and 'makes' the C1 and C2 contacts.

THE BLOWER MOTORS

Model Smiths FHM 5342/01

Two identical motors are utilised in the system: the fresh air blower situated in the inlet ducting beneath the wing, and the recirculation blower mounted in the recirculation inlet duct beneath the front floor, to the rear of the lower evaporator.

Each motor and fan is mounted in a cast aluminium housing (see Fig. 9).

The motor shaft is carried in self-lubricating spherical bushes which are self-aligning to ensure smooth operation.

Two speeds — medium and high — are provided by the incorporation of a resistance in the circuit, which is by-passed when the upper airstream control knob is pulled outwards, or the lower airstream switch is turned to the third position clockwise or the second position anti-clockwise.

RESISTANCES — BLOWER MOTORS

Two resistances — one for each blower motor — are used to provide medium motor speed when placed in circuit.

Each resistance consists of a 66-inch length of oxidised wire forming a winding of 70 turns giving a resistance of 2.8 ohms. The resistance is held in a spool-type ceramic insulator bolted to a Bakelite mounting block which is attached to the bulkhead (see Fig. 10).

The resistance for the fresh air blower is mounted on the upper right-hand side of the bulkhead and the recirculation blower resistance on the upper left-hand side of the bulkhead.



B 102

Fig. 10 Resistance — blower motor

SECTION C.4

THE COMPRESSOR, CONTROL VALVES
AND ANCILLARY UNITS**THE COMPRESSOR**

The compressor fitted to the Silver Cloud II and Bentley S.2 is the Tecumseh HH vertical twin cylinder unit, with an Eaton electromagnetic clutch (see Fig. 12).

Replacement units are readily available and it is not recommended that any major overhaul work be attempted, except by the manufacturers. The valve plate, oil seal, clutch bearing, and the brush unit may be renewed as necessary.

Fault diagnosis

When carrying out pressure tests, a low reading on the high pressure side indicates an inoperative valve or defective gasket. To confirm the diagnosis, reduce the engine speed to 'slow idle' and turn the compressor low pressure service valve clockwise to the forward-seated position. The compound gauge should register 12 in. to 18 in. Hg almost immediately if the intake valve is satisfactory.

Switch off and observe the gauge readings. A leaking shaft seal will permit a rise to atmospheric pressure. A rise above atmospheric pressure indicates a defective gasket, or that the delivery valve is not seating correctly.

Before disturbing any compressor joint, close the service valves to seal off the system and release the pressure from the head as described for the oil level check.

When the cylinder head is removed, examine the valves and cylinder bores. A damaged valve will necessitate changing the valve plate assembly; where a cylinder bore is badly scored, a replacement compressor must be fitted.

When re-assembling, clean all joint faces carefully and immerse the new gaskets in clean refrigerant oil before fitting.

The compressor — To remove and fit

Remove the magnetic clutch (see Page 16).

Forward-seat both compressor service valves and release the compressor pressure, as described for the oil level check. Release the Allen screws securing the service valves to the compressor. Remove the gauze filter from the compressor inlet port, together with the fibre washer.

Unscrew the four compressor securing setscrews situated beneath the compressor mounting bracket and remove the compressor unit, leaving the service valves connected to the pipes.

When fitting the compressor, secure all connections, then purge the air (see Page 18), and turn both service valves anti-clockwise until fully back-seated.

Test for leaks under operating conditions and static conditions. Install the gauge set, check the pressures, and ensure that the complete system is functioning correctly.

The magnetic clutch — compressor

The clutch consists of an electromagnetic fly-wheel driven by twin 'Vee' belts from the engine, and a drive plate attached by a flexible coupling plate to the forward end of the compressor crankshaft (see Fig. 3).

The flywheel is constantly driven by the engine and when the circuit is open, idles on a single bearing carried on the drive plate shaft. When the circuit is closed, current to energise the electromagnet is conveyed through two carbon brushes mounted on the compressor body and two copper collector rings attached to the inner face of the flywheel. The electromagnet attracts

the drive plate which is fitted with a fibre friction facing to take up the drive to the compressor.

To remove and fit

Remove the single retaining bolt and withdraw the flywheel and drive plate assembly from the crankshaft. Care should be exercised when removing the assembly to ensure that the brushes are not damaged.

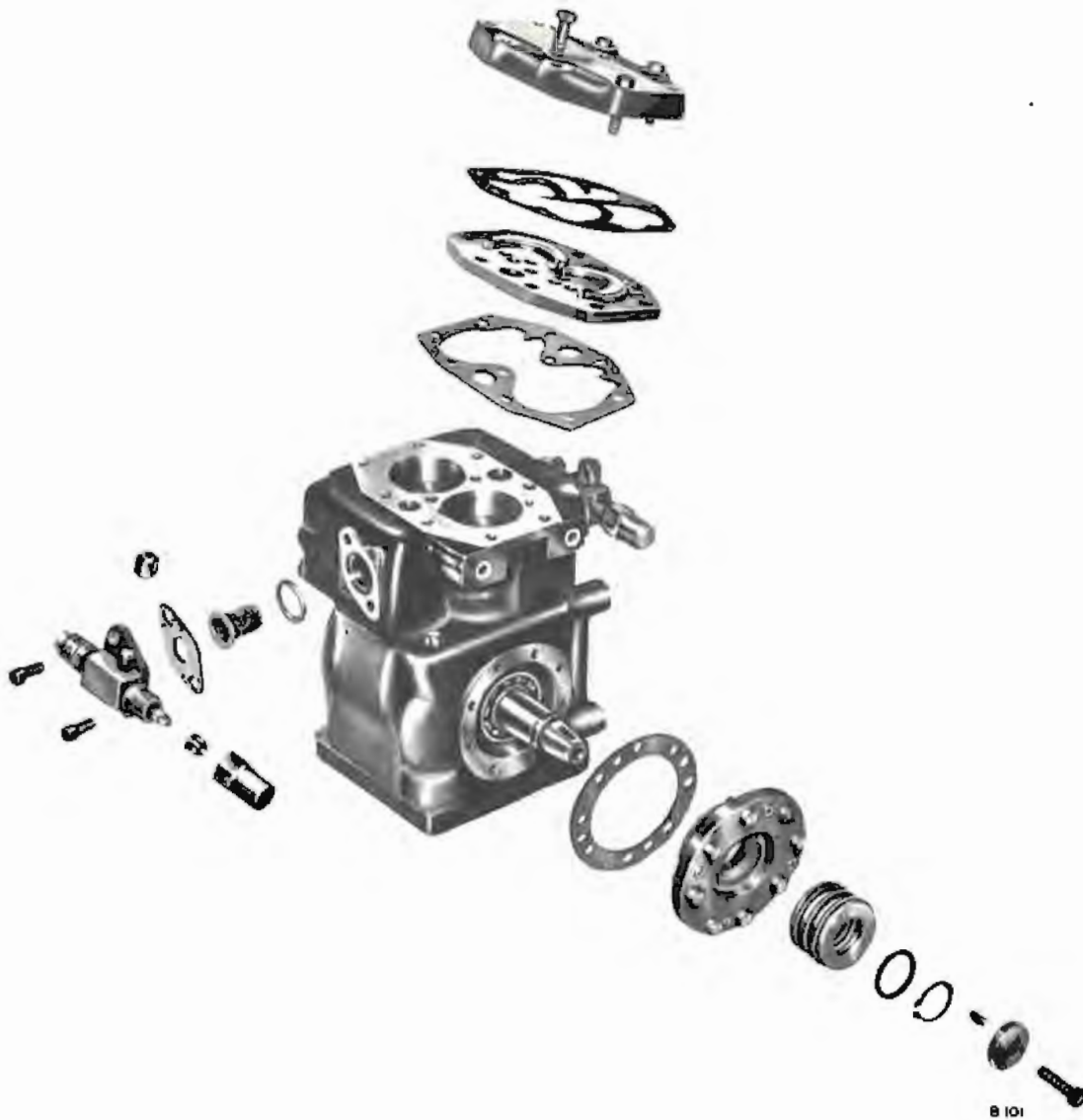

Fig. 11 Compressor – exploded view

Remove the retaining circlip and withdraw the drive plate. Inspect the plate for wear of the fibre facing and for cracked springs or loss of tension; renew the plate if necessary. Examine the bearing for wear and clean the collector rings.

Re-assemble the clutch and set the air gap between the two drive faces by means of the three adjusting screws in the drive plate. The gap should be 0.025 in. to 0.035 in.

Examine the brushes for wear and renew the brush unit if necessary.

Note: Failure of the clutch may be due to the presence of grease or oil on the collector rings and brushes. This should be removed with a cloth moistened with petrol, and the unit assembled and tested.

Shaft seal — To replace

With the clutch assembly removed from the compressor, press in the sealing ring seat and extract the circlip to permit withdrawal of the seal assembly.

Remove any roughness from the shaft surface by lightly stoning, then coat all parts with refrigerant oil before re-assembling.

Lubricant

The following proprietary lubricants are approved:

Mobil Gargoyle Arctic 155

Wakefield Icematic Heavy

Shell Clavus 33

New compressors are supplied dehydrated and containing the correct quantity of oil. When a new compressor is installed, it is possible that some oil will remain in the system, therefore the oil level must be checked and if necessary adjusted.

The oil level must also be checked when any refrigerant is extracted from the system.

The correct oil level, when checked by a dipstick, should be between $1\frac{1}{8}$ in. and $1\frac{1}{2}$ in.

Oil level — To check

Run the engine at fast idle with the refrigeration system operating, until the compressor is fully warmed (approximately 10 minutes) to ensure that no liquid refrigerant remains in the compressor crankcase. Forward-seat the low pressure service valve, run the engine for a further minute and



Fig. 12 Magnetic clutch — compressor

switch off. Forward-seat the high pressure service valve immediately. *Do not operate the compressor with the high pressure valve closed.*

Carefully slacken the gauge attachment capnut on each service valve to release the gas pressure from the head, then re-tighten. Thoroughly clean and dry the area around the oil filler plug and slowly remove the plug so as to gradually release the gas pressure from the crankcase.

When releasing gas pressures, protective goggles must be worn to prevent any possibility of refrigerant coming into contact with the eyes.

Measure the oil depth, using a dry, clean rod approximately $\frac{1}{8}$ in. diameter. It may be found necessary to rotate the compressor slowly by hand to allow the 'dipstick' to pass the crank balance weights.

Adjust the oil level by means of a syringe, adding or drawing-off oil as necessary. Refit the filler plug loosely; do not tighten the plug as it is necessary to purge the air from the compressor.

Note: It is recommended that oil be used only from a sealed container.

To purge the air from the compressor

Slacken the protective cap on the high pressure service valve. Open the low pressure service valve very slightly and allow gas to pass through the compressor for about ten seconds. Whilst the gas is still passing, tighten the oil filler plug and then the valve capnut.

Back-seat both service valves and refit the protective caps.

THE CONDENSER

The condenser matrix is situated between the radiator matrix and the intake grille (see Fig. 13). Its purpose is to cool refrigerant gas delivered by the compressor and condense it; the liquid refrigerant then passes into the receiver.

The matrix comprises two banks, each of sixteen horizontal tubes. A single inlet pipe conveys compressed refrigerant to a 'Tee' junction at the head of the matrix. This junction supplies the



Fig. 13 Condenser matrix

two banks independently. At the base of the matrix another junction connects them to the single outlet.

A by-pass pipe to the flow control valve permits high pressure vapour to flow back to the side of the compressor when the valve is open.

THE RECEIVER

The receiver is a steel container of welded construction, secured by three bolts to a bracket forward of the frame front cross-member (see Fig. 14).

The inlet pipe union is situated at the top of the container; the outlet union is positioned midway down the right-hand end-face. Inside the receiver, a pipe attached to the outlet union bends downward to the base of the unit in order to ensure that liquid refrigerant only will pass to the drier.

A fusible plug, inserted at the base of the unit (see Fig. 14), prevents explosion in the event of

fire. Under no circumstances must this be replaced by a solid plug.

THE DRIER

The drier unit is mounted below the right-hand front apron and in the liquid line between the refrigerant receiver and the twin solenoid valves (see (Fig. 14).

The unit consists of a steel tubular shell fitted with flared connections at the inlet and outlet. Screwed into the inlet port is a metal gauze filter to prevent the ingress of coarse impurities and to protect the dehydration charge, which is granulated silica-gel. At the outlet end, a felt pad, retained by a perforated metal plate, prevents the ingress of fine impurities.

The drier unit and the dehydration charge should be renewed alternately at intervals of 10,000 miles, i.e. after 10,000 miles, renew the unit; after 20,000 miles, renew the charge only.

The charge must also be renewed if for any reason the system is opened to remove a faulty unit.

To remove the unit, release the pipe union at each end of the shell.

To renew the charge, remove the union situated at the inlet end, clean the gauze filter and check to ensure that the felt filter is not obstructed. Extract the spent charge and replace by a fresh quantity of silica-gel.

THE EXPANSION VALVES

Two expansion valves are used, each valve controlling the atomisation of the refrigerant entering its respective evaporator matrix.

The valve body is a brass stamping and basically comprises an inlet passage, valve chamber and an outlet bore; the inlet and outlet bores are fitted with flared connections. A renewable gauze filter is provided in the inlet bore to prevent the ingress of coarse impurities which could obstruct the valve orifice.

The valve is operated by the pressure difference in a hermetically sealed chamber containing a



1 DRIER 2 RECEIVER
3 FUSIBLE PLUG

Fig. 14 Drier and receiver

bellows system. The interior of the bellows is connected to the valve chamber by a single drilled hole.

The bellows exterior surface is subjected to pressure governed by the phial clipped to the return pipe from the evaporator and connected to the valve by a capillary tube (see Fig. 2). Expansion and contraction of the bellows operates the valve by moving three pins, which act on a spring-loaded piston attached to the valve seat. The spring tension is varied by means of an adjusting spindle, the squared end of which is protected by the capnut at the base of the valve. Adjustment of the spring tension effectively adjusts the degree of superheat; this is set during initial testing at the factory and should require no re-adjustment.

In the event of adjustment being necessary, it will be noted that one complete turn clockwise of the spindle corresponds to approximately 3.6°F. (2°C.) decrease to the superheat. The cap must always be tightened after each adjustment, otherwise refrigerant may escape or moisture may enter the system.

THE FLOW CONTROL VALVE

The flow control valve is mounted midway along the right-hand valance and is connected in the by-pass line between the compressor pipe and the condenser.

The purpose of this valve is to maintain a minimum pressure of 2 lb./sq. in. on the low pressure side of the system. To maintain this pressure, high pressure vapour from the condenser is cooled by expanding it through the valve, before re-introducing it to the suction side of the compressor. This prevents too heavy a pressure drop in the compressor crankcase, which could cause priming of the oil.



Fig. 15 Flow control valve

The outlet port (compressor suction line) is directly connected with the valve chamber and the interior of a spring-loaded bellows system. The bellows exterior is subjected to pressure in a sealed chamber; thus the valve chamber pressure acts in opposition to the spring force and the pressure in the sealed chamber.

When the suction line pressure, and therefore the valve chamber pressure, falls to 2 lb./sq. in., the valve will be opened by the spring.

A combined friction and bellows damping device is incorporated to prevent too-frequent valve operation caused by rapidly fluctuating conditions.

An adjusting screw is fitted in the top of the valve to vary the spring force and thus the valve opening pressure. This is set during initial testing and should require no further adjustment. Should adjustment be necessary, the screwed cap must always be tightened afterwards.

SECTION C.5

MAINTENANCE

No regular maintenance will be necessary other than that required at the specified intervals, but it should be noted that whenever the car enters a Service Department for periodic maintenance, the system should be checked for satisfactory operational effect.

The following schedules outline the necessary periodic maintenance operations.

SCHEDULES

Every 2,500 miles

Check the tension of the compressor driving belts. A 6 lb. load applied to each belt at the mid-point of the run between the compressor and generator pulleys should cause the belt to deflect $\frac{1}{8}$ in.

Every 5,000 miles

In addition to the foregoing, the following points require attention.

Apply a few drops of engine oil to the flap actuator linkages.

Examine the condenser matrix and remove all obstructions.

Inspect the filters in the fresh and recirculated air intakes for damage or blockage.

Note: These filters are self-cleaning and will generally require no attention.

Every 10,000 miles or annually, whichever is the shorter period

Discharge the system until the pressure falls to approximately 5 lb./sq. in.

Remove and clean the two filters situated in the expansion valve inlet bores, by releasing the flared connections.

Remove the gauze filter from the compressor inlet port, clean and refit (see Page 15).

Renew either the silica-gel charge or the complete drier unit (see Page 19).

Check and adjust the compressor oil level (see Page 17). Inspect the magnetic clutch collector rings for the presence of oil or grease, and check that the carbon brushes are not badly worn. Renew the brush unit if necessary (see Page 17).

Adjust the tension of the compressor driving belts (see 2,500 miles schedule).

Lubricate the flap actuator linkages.

Examine the condenser matrix and the air intake filters and remove any obstructions.

Evacuate, sweep and charge the system (see Pages 27 to 29). Check all connections for leakage.

Operate the system throughout the full range of switch positions and ensure that all the components function correctly.

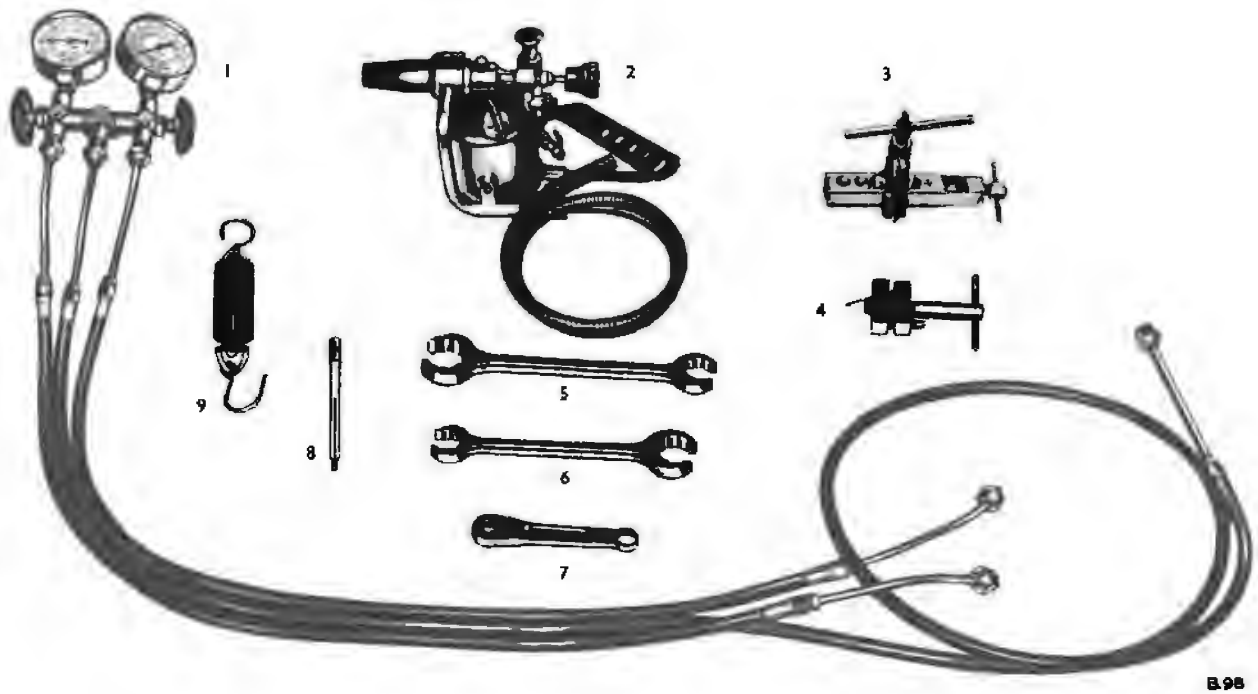

- | | | | |
|---|--------------------|----------------|--------------------------------------|
| 1 | MANIFOLD GAUGE SET | 5 | SPANNER 1.125 in. A/F x .875 in. A/F |
| 2 | LEAK DETECTOR LAMP | 6 | SPANNER 1.00 in. A/F x .750 in. A/F |
| 3 | TUBE FLARING TOOL | 7 | RATCHET WRENCH .250 in. SQUARE |
| 4 | TUBE CUTTING TOOL | 8 | THERMOMETER |
| | 9 | SPRING BALANCE | |

Fig. 16 Service tools

SECTION C.6

SERVICING

SPECIAL TOOLS REQUIRED

Part No.	Description	Number off
RH.527	'Blaydon' leak detector lamp, or similar model	1
RH.528	Tube flaring tool	1
RH.529	Spring balance, 0-25 lb.	1
RH.530	Thermometer	1
RH.531	Spanner, ring, 1.125 A/F × 0.875 A/F	1
RH.532	Spanner, ring, 0.750 A/F × 1.00 A/F	1
RH.533	Wrench, ratchet, 0.250 square	1
RH.534	Tube cutting tool	1
RH.538	Manifold gauge set assembly	1

Also: A pair of goggles and a First-Aid kit containing medicated liquid paraffin, and saline wash.

PRECAUTIONS TO BE OBSERVED WHEN HANDLING REFRIGERANT**Exposure to refrigerant**

Large quantities of refrigerant gas discharged into a confined space will displace the oxygen in the air and could cause suffocation.

Liquid refrigerant which may accidentally escape is at least 20°F. below zero and if allowed to come into contact with the skin it can cause a burn by the rapid transference of heat from the skin to the liquid as it evaporates. Serious damage to the eyes will result from contact with liquid refrigerant. For this reason, goggles should always be worn when contact might be possible.

Should liquid refrigerant come into contact with the eye, *immediate first-aid treatment is necessary* and a doctor or eye specialist should be consulted as soon as is possible.

First-Aid treatment

Medicated liquid paraffin from the first-aid kit should be applied to the eye from an eye dropper,

to wash away the Freon. The eye should not be rubbed, as this will increase the area of injury. If the eye remains painful after a few minutes, the wash should be repeated, using a sterile salt solution containing not more than 2% sodium chloride.

THE IMPORTANCE OF CHEMICAL STABILITY

The efficient operation of the system is dependent upon the pressure-saturation temperature relationship of pure Freon 12. So long as the system contains only pure Freon 12 (plus a certain amount of compressor lubricant which mixes with the Freon), it is considered to be chemically stable.

When foreign materials such as dirt, air or moisture are allowed to enter the system, they will affect chemical stability, change the pressure-saturation temperature relationship of the Freon, and possibly cause freezing-up of the expansion valve. Thus, the system will no longer operate at the correct pressures and temperatures, with a consequent decrease in efficiency.

The sealing of components

Whenever it becomes necessary to break a refrigerant connection, the exposed ends should be immediately capped. Air entering the system will carry moisture, which collects quickly on any exposed surface, causing deterioration, owing to the acidic properties of an air-Freon compound.

FAULT DIAGNOSIS

In order to facilitate fault diagnosis, the unit may be considered as two separate systems, viz. the air delivery system and the refrigerant circulation system; these should be checked independently. The upper and lower airstream switches individually control air delivery through the fresh air and recirculated air ducting respectively.

Air delivery

Switch on the blower motors and check the air delivery at the duct outlets. This should be carried out over the full range of switch positions.

Failure of one system in all switch positions indicates a blocked intake or filter, a defective blower motor or flap actuator, or faulty wiring.

Failure of the fresh air blower motor to operate when the knob of the upper airstream switch is in the pushed-in (medium speed) position only, indicates a defective resistance or switch or a wiring fault. Failure of the recirculation blower motor to operate in the medium speed positions (1st and 2nd clockwise and 1st anti-clockwise) of the lower airstream switch will probably be due to a similar defect.

A failure in one switch position will probably be caused by defective switch contacts. Complete failure indicates a fuse, switch or wiring defect.

Refrigerant circulation

Initial procedure

Site the car in a well ventilated and shady position. Check the tension of the compressor driving belts and the external cleanliness of the condenser, as detailed in the Maintenance Schedule.

Start the engine and allow it to run at a fast idle, operating the refrigeration system with the blower motors at full speed. Visually check that the magnetic clutch is operating.

Fault location

An obstructed condenser matrix cannot function efficiently and will result in insufficient cooling and high compressor head pressures.

Blowers and compressor operating — No cooling

Possible causes are as follows:—

1. Low refrigerant charge.
2. An inoperative thermostat or solenoid valve.
3. A restriction in the refrigerant circuit.
4. Incorrect functioning of the compressor valves.

5. A faulty expansion valve.
6. Blower motor incorrectly installed.

The following action should be taken:—

1. Check the system for leaks and rectify, then re-charge.
2. Test the operation of the thermostat and solenoid valves and adjust or renew a faulty thermostat; service or renew a defective solenoid valve.
3. Inspect all hoses and pipes for kinks and check that the expansion valves are operating.
4. Test compressor head pressures and valves (see Page 15).
5. Test the expansion valves for correct operation; if faulty, remove and clean or if necessary renew the unit.
6. Check that the blower motor and impeller housing have not been installed facing in the reverse direction. This will cause a flow out of the intake. Reversing the motor leads will not effect a cure.

Blowers operating — Partial cooling

Possible causes:

1. Low refrigerant charge.
2. A defective expansion valve.
3. The compressor operating above normal pressure.
4. Restricted condenser tubes or discharge line.
5. A faulty thermostat or solenoid valve.
6. The condenser matrix obstructed.
7. Incorrect refrigerant.

Action to be taken:

1. Check the system for leaks and re-charge.
2. Test the expansion valve, clean, adjust or renew.
3. Test the compressor head pressures (see Page 15) and if necessary inspect the valves.

4. Discharge the refrigerant, remove the discharge line, and inspect it for signs of restriction. Inspect the condenser for kinked or obstructed tubes; apply dry compressed air or nitrogen to the tubes to dislodge obstructions or, if necessary, renew the unit.
5. Test the thermostats and solenoid valves for correct operation, check the wiring connections.
6. Inspect the condenser matrix for obstructions and remove any foreign matter by cleaning the matrix with warm water and applying compressed air from the side adjacent to the radiator.
7. Test the pressure-saturation temperature relationship of the refrigerant (see Page 26).
5. Inspect the temperature control phials for maximum contact with their adjacent pipes, and examine the phials and capillary tubes for damage. Renew the complete valve unit if damage prevents correct operation.
6. Remove and clean the expansion valves and filters.
7. Carry out the pressure test (see Page 15), if this reveals a faulty valve, renew the valve plate assembly.

Low suction pressure and high head pressure

The probable cause is a blockage in the discharge pipe or condenser tubes. The obstruction should be removed or, if necessary, the component renewed.

High suction pressure and high head pressure

Probable causes are:

1. The superheat setting of the expansion valve or valves is too low, causing the admission of liquid refrigerant to the compressor.
2. An obstructed condenser matrix.
3. The presence of air and/or moisture in the system.
4. Too great a quantity of refrigerant.

Action to be taken:

1. Test the expansion valves and adjust or, if necessary, renew a faulty valve.
2. Wash the external surfaces of the condenser matrix with warm water and free the matrix of obstructions by applying compressed air to the face of the matrix adjacent to the radiator.
3. Discharge the system and re-charge it with the correct quantity of refrigerant.
4. Évacuate and re-charge the system.

Suction pressure correct but head pressure high

Probable causes are:

1. The presence of air in the system.
2. Too great a charge of refrigerant.

Low suction pressure and low head pressure

Possible causes:

1. Refrigerant charge low.
2. Filter-drier unit obstructed.
3. An obstruction in the liquid line.
4. An incorrect expansion valve superheat setting.
5. A damaged temperature control phial or a phial not correctly in contact with its adjacent pipe.
6. An expansion valve filter or port plugged with moisture or grit.
7. Faulty compressor valves.

Action to be taken:

1. Check the system for leaks and re-charge.
2. Clean the filter and renew the dehydration charge or renew the complete unit.
3. A partial blockage in the pipe will create a temperature fall at the point of restriction; this will be obvious to the touch. Remove the pipe from the unit and remove the obstruction, using dry compressed air or, if necessary, fit a new pipe.
4. Check the superheat reading (see Page 26), reset or, if necessary, renew the expansion valve.

Action to be taken:

1. Check the suction side of the system for leaks and rectify. Discharge the refrigerant, renew the dehydration charge in the drier, and evacuate. Re-charge with the correct quantity of new refrigerant.
2. Discharge the refrigerant and re-charge with the correct quantity.

Head pressure correct but suction pressure low
Probable causes are:

1. Blower motor or motors not functioning.
2. Restricted filter-drier.
3. The Superheat setting of the expansion valve or valves too high.

Action to be taken:

1. Check the blower motor operation.
2. Test the filter-drier and renew it if the filters are choked.
3. Check the superheat settings.

Pressure tests

Switch off and install the manifold gauge set with both its valves firmly closed. Remove the protection caps from the compressor service valves and just crack open both valves by rotating one half-turn clockwise.

Warning: During these tests it is essential that the compressor service valves are not fully open, as this closes the system delivery and intake valves and could possibly cause an explosion.

Run the engine at fast idle with the refrigeration system operating and the blower motors at full speed.

Turn the compressor service valves anti-clockwise to damp out any gauge fluctuation.

The compound gauge reading should be 20 to 35 lb./sq.in. With the following ambient air

temperatures (temperature in the shade) the pressure gauge reading should be:—

60°F.	(15.6°C.)	100-150 lb./sq.in.
80°F.	(24.7°C.)	140-190 lb./sq.in.
100°F.	(37.8°C.)	180-240 lb./sq.in.
110°F.	(43.3°C.)	230-280 lb./sq.in.

Superheat test

The system may be checked for correct operation by testing the upper and lower evaporators individually as follows:—

Attach the thermometer RH.530 to the suction pipe from the evaporator. Cover the thermometer bulb and the pipe with a thick cloth to provide insulation from atmospheric temperature, leaving the scale visible. Allow the engine to run for a few minutes at 1,200-1,800 r.p.m. with the refrigeration system operating. Read the thermometer, and the compound gauge at the compressor. Add 3 lb./sq.in. to the gauge reading to compensate for pressure drop in the suction line.

Refer to the following table to obtain the saturation temperature corresponding to this pressure and subtract this figure from the thermometer reading. The result should be between 8° and 15°F. which is termed the 'Superheat Reading'.

Having obtained the correct values, any inefficiency can only be attributed to poor air delivery. In such cases, check the blower motor operation and ensure that the inlet and outlet ducts are unobstructed.

TO DISCHARGE THE REFRIGERANT

The refrigerant must be discharged from the system prior to breaking any joint, except the compressor unit joints which are protected by the service valves.

Do not discharge in the presence of an open flame; the refrigerant does not burn, but decomposes to form a poisonous gas.

Remove the protective caps from the compressor service valves. Just 'crack' the high pressure valve in a clockwise direction, allowing

Pressure-Saturation Temperature Relationship Table — Freon 12.

Pressure lb./sq.in.	Temperature ° F.	Pressure lb./sq.in.	Temperature ° F.
20	19.5	36	39
21	21	37	40
22	22	38	41
23	23.5	39	42
24	24.5	40	43.5
25	25.5	41	44.5
26	27	42	45.5
27	28.5	43	46.5
28	29.5	44	47.5
29	31	45	48.5
30	32.5	46	49.5
31	33.5	47	50.5
32	34.5	48	51.5
33	36	49	52.25
34	37	50	53
35	38		

the refrigerant in the system to be discharged to atmosphere. Care must be taken not to release the refrigerant too quickly as this will result in oil being drawn from the system. The operation should require at least fifteen minutes to ensure complete discharge.

Always use two spanners in opposition when releasing and securing flared connections, to prevent damaging the flares or tubes.

On completion of repair work it is necessary to evacuate and sweep the system to remove all moisture before re-charging. The compressor oil level should be checked, as described under 'Compressor'.

TO EVACUATE THE SYSTEM

The use of a vacuum pump for evacuation is advisable but if this is not available the compressor may be utilised as follows:—

Fit the manifold gauge set to the compressor as illustrated in Figure 17. Forward-seat the compressor high pressure service valve by turning it clockwise to the end of its travel. Open the pressure valve of the manifold gauge set by turning it fully anti-clockwise.

Close the vacuum valve of the manifold gauge set by turning it clockwise. Just 'crack' the low pressure service valve by rotating it one half turn clockwise.

Start the engine and switch on the blower motors to 'Fast' speed. Observe the vacuum gauge and when a vacuum of 28 inches Hg is reached, allow the compressor to continue drawing a vacuum for a further 10 minutes, then switch off the system and close the pressure valve on the manifold gauge set. These two operations must be carried out simultaneously, necessitating two operators.

Switch off the ignition and allow 20 minutes for conditions to settle before taking a reading of the vacuum gauge. This reading should be maintained for 5 hours. If a drop in vacuum is evident after this period, a leak in the system is indicated (see under leak detection).

TO SWEEP THE SYSTEM

Back-seat the high pressure service valve by turning it fully anti-clockwise. Forward-seat the low pressure service valve by turning it clockwise. Connect the centre union of the manifold gauge set to a Freon 12 container. Close both valves on the manifold gauge set by turning them clockwise.

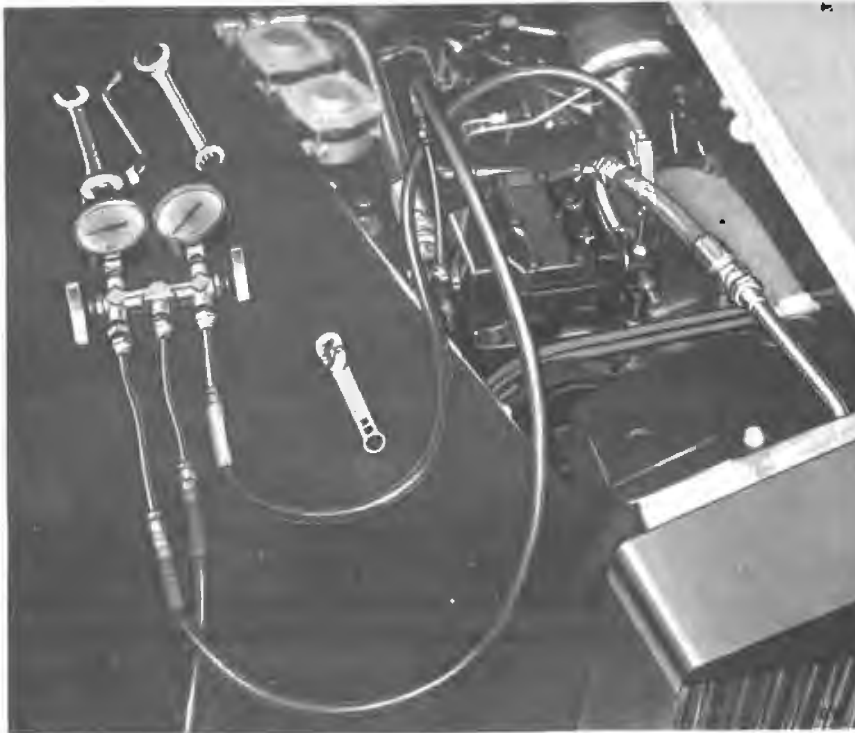

Fig. 17 Manifold gauge set in position

Open the valve of the Freon 12 container, purge the air for a few seconds and then re-tighten. Attach a spring balance to the container and record the weight.

Open the vacuum valve of the manifold gauge set and allow 1 lb. of gas to pass into the system. In some cases, when the temperature (and therefore the pressure) is low, it may be necessary to start the engine and switch on the system in order to draw in the refrigerant. Owing to the variation in the time taken to charge, the weight of refrigerant remaining in the container must be checked frequently. Do not allow the pressure reading on the compound gauge to exceed 50 lb./sq.in. This can be controlled by regulating the manifold gauge set vacuum valve.

Switch off the compressor and the ignition. Close the manifold gauge set vacuum valve and back-seat the compressor low pressure service valve by turning it anti-clockwise. Close the valve of the refrigerant container and disconnect the centre hose. Start the engine and operate the

system for approximately 10 minutes with the blower motors at full speed.

Switch off the system and switch off the ignition.

If the system fails to hold the vacuum when testing, it is necessary at this stage to locate the leak; this is possible because the system is under pressure and escape of refrigerant can be detected (see Section on Leak Detection). If the system maintains the vacuum it is ready for charging upon completion of the sweeping operation.

Ensure that the valves on the manifold gauge set are closed. Turn the high pressure service valve two complete turns clockwise.

Drain the system by slightly opening the pressure valve of the manifold gauge set.

TO CHARGE

Before charging, it is necessary to draw out the refrigerant remaining from the sweeping operation. Repeat the evacuation process (see Page 27).

Back-seat the high pressure service valve and forward-seat the low pressure service valve. Connect the centre union of the manifold gauge set to the refrigerant container and open the valve of the container. Break the joint of the manifold centre hose and purge the air for a few seconds, then re-tighten.

Attach a spring balance to the refrigerant container and record the weight. Open the vacuum of the manifold gauge set.

Start the engine and switch on both blower motors. If the refrigerant does not flow into the system, even with the compressor in operation, place the container in a bucket of warm water not exceeding 113°F. *Do not apply a flame, or localised heat. This could cause an explosion.* Do not allow the reading on the compound gauge to exceed 50 lb./sq.in. This can be controlled by regulating the vacuum valve of the manifold gauge set.

When 7 lb. of refrigerant has been drawn into the system, switch off the ignition and close the vacuum valve of the manifold gauge set.

Close the valve of the Freon 12 container and disconnect the centre hose. Back-seat both service valves on the compressor. Disconnect and remove the manifold gauge set and refit the protective covers on the service valves. Check the system for leaks, adopting the following procedure.

TO CHECK FOR LEAKS

Leak detection should be carried out at full operating pressure and under static conditions, using the Detector Lamp RH.527 (see under pressure tests for appropriate figures). In order to obtain the correct pressure, it may be necessary to re-charge the system.

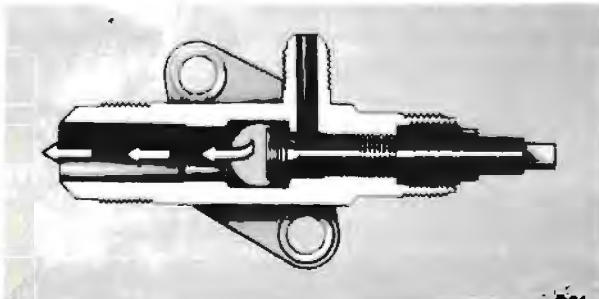

Fig. 18 Compressor service valve — backward-seated

Pass the end of the detector lamp flexible hose over all points where leaks are possible. The colour of the lamp flame will change to green when the open end passes over a leak point.

Note: It is important not to operate the lamp pressure pump when in the vicinity of possible leaks, as refrigerant will be drawn into the fuel container of the lamp, causing the flame to remain green for some time. Furthermore, the car should be placed in an adequately ventilated position, otherwise refrigerant may persist in the vicinity of the car and give misleading results.

RIGHT-HAND FRONT WING — TO REMOVE

Should it be necessary to remove the wing in order to carry out leak detection tests or to remove the underwing unit, the following procedure should be adopted:—

The right-hand front door and the radiator shell must first be removed in order to gain access to the wing securing bolts:—

Open the right-hand front door and place a suitable support beneath the door to take its weight. Remove the split pin and clevis pin from the checkstrap.

If electrically operated windows are fitted, it will be necessary to remove the three screws securing the conduit to the hinge post before unscrewing the six hinge bolts.

The door may then be removed unless this is prevented by the leads to the electrically operated window, in which case the door should be moved rearwards to the extent of the leads.

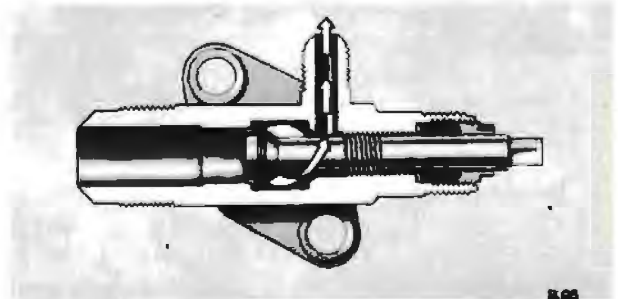

Fig. 19 Compressor service valve — forward-seated

Unscrew the four bolts which secure the top of the radiator shell to the matrix and the bonnet centre stay, also the eight bolts securing the lower end of the shell to the under-tray and the front apron.

Remove the four bolts securing the front apron to the side fairings, also the four nuts, bolts and washers securing the right-hand side fairing to the wing.

Remove the side fairing, the front apron, and the radiator shell.

The wing panel can then be removed as follows:—

Remove the six bolts from the rear vertical edge of the wing, also two self-tapping screws and one bolt which secure the stainless steel strip to the lower edge.

Remove six bolts from the lower edge and front vertical edge of the wing.

Support the weight of the wing and remove the ten bolts securing the wing to the valance. Disconnect the headlamp and side lamp cables and remove the wing panel.

Should the cables for the electrically operated window have prevented removal of the door, it will be advisable to temporarily re-secure the hinges.

UNDERWING UNIT — TO REMOVE

Should the detection of a leaking matrix or similar fault necessitate the removal of the matrices and underwing ducting, proceed as follows.

Discharge the refrigerant from the system (see Page 26).

Remove the right-hand front wing (see Page 29).

Forward-seat the compressor low pressure service valve by rotating clockwise to the full extent of travel. Disconnect the evaporator return pipe union at the junction adjacent to the flap actuators.

To prevent loss of engine coolant when disconnecting the pipes from the heater matrix, drain the radiator matrix, or alternatively, seal the heater pipes immediately they are disconnected, by inserting $\frac{3}{8}$ in. bolts into their bores and clamping the hoses with worm drive clips.

Disconnect the two pipe unions at the forward ends of the solenoid valves.

Slacken the worm drive clip situated at the forward end of the recirculation ducting.

Disconnect the transfer duct thermostat at the rear snap connector leads.

Unscrew the seven nuts securing the underwing unit to the valance.

Disconnect the fresh air blower motor leads at the snap connectors, then slide the underwing unit off the motor housing, allowing the motor leads to pass through the hole in the ducting; remove the unit from the car.

Remove the two actuator coupling tubes, situated within the rubber seals protruding from the valance.

UNDERWING UNIT — TO FIT

Pass the blower motor leads through the hole in the front ducting and place the unit in position against the valance, so that the six mounting studs protrude through the valance, the rear duct locates on the recirculation duct and the intake end fits over the housing of the fresh air blower motor. Secure the unit to the valance by fitting washers and nuts to the mounting studs and refitting the bolt, washer and nut at the top of the unit. Tighten the worm drive clip on the recirculation duct and seal with adhesive tape the joint between the ducting and blower housing.

Connect the coolant hoses to the heater matrix pipes; the hose from the water tap should be connected to the lower pipe from the matrix. Secure the hoses with worm drive clips.

Top-up or refill the radiator matrix with the correct anti-freeze mixture.

Attach the blower motor leads and the transfer duct thermostat leads to their respective connectors.

Connect the pipes between the expansion valves and the solenoid valves.

Secure the evaporator return pipe union at the valance Tee junction.

Evacuate and sweep the system, then check for leaks (refer to the appropriate Sections).

Charge the system with 7 lb. of refrigerant (see appropriate Section).

Fit the wing.

Check and, if necessary, reset the actuator adjustment.

AIR CONDITIONING REFRIGERATION

O.M.C. UNIT

CONTENTS

DESCRIPTION	SECTION C1
OPERATING THE SYSTEM	SECTION C2
ELECTRICAL COMPONENTS	SECTION C3
COMPRESSOR, CONTROL VALVES AND ANCILLARY UNITS	SECTION C4
MAINTENANCE	SECTION C5
SERVICING	SECTION C6

Published by
The Technical Publications Department
Rolls-Royce Limited
Pym's Lane,
Crewe

(T.S.D. Publication 744)

Printed in Great Britain by William Hodge & Chilver Limited, London

INDEX

	<i>Page</i>
Description	C1
Operating the System	
Introduction	C5
To Operate (No. 1 Installation)	C5
To Operate (No. 2 Installation)	C5
Electrical Components	
Blower Motors	C7
Blower Motor Resistances	C7
By-pass Solenoid Valve	C9
Rear Window De-mister Relay	C9
Thermostat Control Switch	C8
The Compressor, Control Valves and Ancillary Units	
Compressor	C11
Fault Diagnosis	
To Remove and Fit	
Condenser	C15
Drier	C15
Lubricants	C13
Oil Level—To Check	
To Purge the Air	
Magnetic Clutch	C11
Eaton Clutch	
Electro Lock Clutch	
Shaft Seal—to Renew	C12
Tecumseh HH	
York A.209	
Maintenance	
Safety Device	C17
Schedules	C17
Storage	C17
Servicing	
Charging	C24
Chemical Stability—Importance of	C20
Diagnosis	C21
Discharging Refrigerant	C23
Evacuating	C23
Fault Location	C20
Air Circulation	
Refrigerant Circulation	
First Aid Treatment	C20
Leak Detection	C24
Precautions	C20
Pressure Tests	C21
Sealing of Components	C20
Superheat Test	C22
Sweeping	C23
Tools	C19

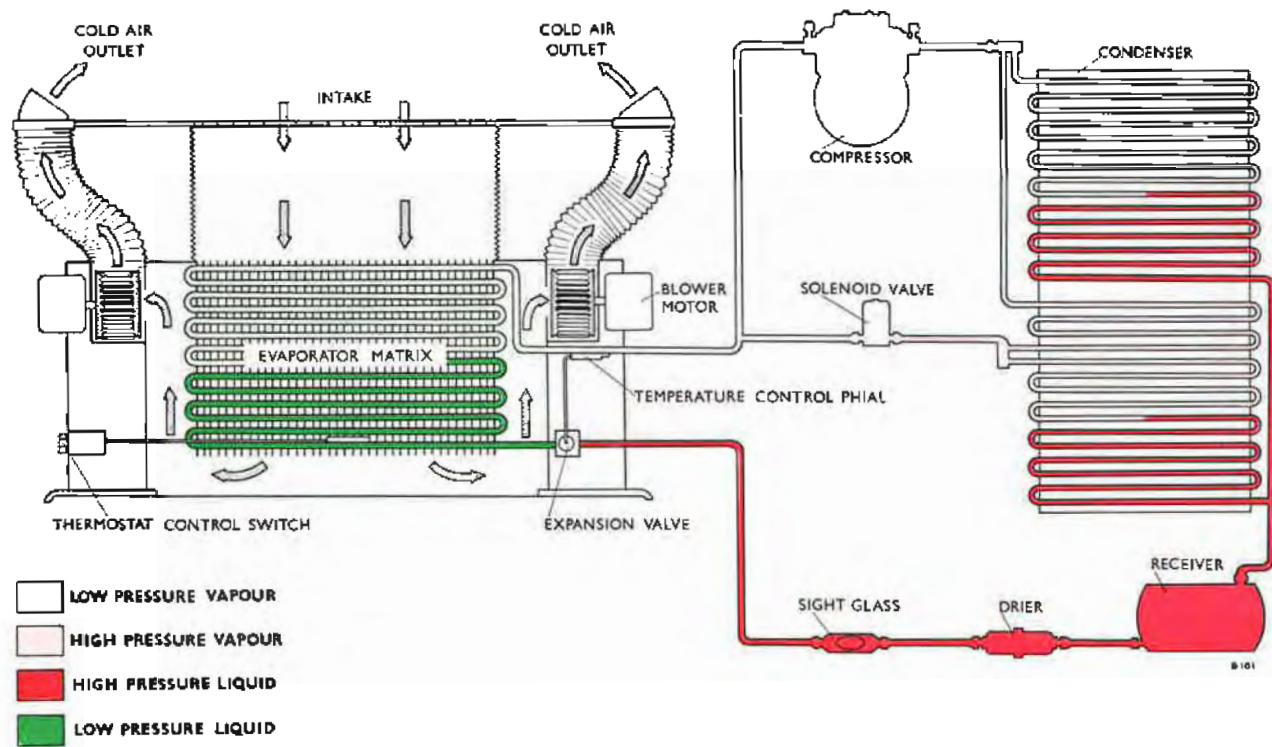

Fig. 1 Refrigerant Circulation Diagram

Section C1

DESCRIPTION

The vapour compression system used on Rolls-Royce and Bentley cars is designed to reduce the temperature and humidity in the saloon when surrounding air temperature and humidity are high.

To achieve greater efficiency, Jablite roof insulation, 'Sundym' (tinted) glass and an exhaust heat shield are used to minimise heat penetration into the car interior.

Circulation of the refrigerant, Freon 12 (DI-CHLORODIFLUOROMETHANE), is maintained by a compressor, driven through the medium of an electromagnetic clutch and Vee belts (see Fig. 2).

The purpose of the compressor is two-fold; to raise the pressure and temperature of the refrigerant vapour and also to pump the refrigerant through the system. The high pressure, high temperature vapour is delivered by the compressor to the condenser which is mounted in front of the radiator matrix. Ambient air passes across the condenser tubes by the forward motion of the car and engine fan action.

This air, which is of a lower temperature than the refrigerant vapour circulating through the condenser, creates a heat transfer between these two media. Condensation of the vapour occurs, creating a liquid refrigerant (see Fig. 3).

The high pressure and high temperature liquid now passes to the receiver, which is a storage tank located just below the condenser, through the filter drier and sight glass to the expansion valve located in the evaporator assembly in the boot (see Fig. 4).

This automatic thermal expansion valve is the dividing point, separating the high pressure and low pressure sides of the system. It automatically meters the high pressure, high temperature liquid refrigerant through a small orifice into the low pressure area of the evaporator coil. The low pressure is created by the pull of the low pressure (suction) side of the compressor.

At this point, as the liquid pressure is immediately decreased, the temperature will correspondingly decrease. Heat laden air from the car interior is passed over the evaporator coil fins and tubes (through which the now cold refrigerant liquid is circulating), by twin blower motors, via the return air ducts.



- 1 HIGH PRESSURE SERVICE VALVE
- 2 LOW PRESSURE SERVICE VALVE
- 3 COMPRESSOR OIL FILLER PLUG

IMPORTANT: REFER TO COMPRESSOR DETAILS FOR INSTRUCTIONS REGARDING THE REMOVAL OF THIS PLUG

Fig. 2 Tecumseh Compressor in Position

The temperature difference created by these two media causes a heat transfer from the warm air to the cold refrigerant liquid. As the liquid refrigerant absorbs the heat from the air, the refrigerant vaporises (or boils) due to the low temperature in the evaporator coil.

The cold, de-humidified air is then discharged through two outlet ducts situated in the rear parcel shelf of the car interior.

Condensation of the air moisture simultaneously occurs with the reduction of the air temperature. This condensation is drained as water out of the evaporator assembly by two drain pipes.

An expansion valve capillary tube strapped to the evaporator coil outlet is sensitive to the temperature of the circulating refrigerant vapour. The pressure corresponding to this temperature is relayed to a diaphragm in the valve which opposes a balancing spring tension. The action of these two opposing forces closes or opens the valve port in relation to the increase or reduction of heat absorbed by the refrigerant vapour beyond the quantity necessary to complete the vaporisation process.

In this manner, the valve automatically meters the correct amount of liquid refrigerant into the evaporator coil depending upon the degree of superheat

existing at the evaporator outlet. It should be clearly pointed out that no attempt to alter the factory setting of the expansion valve should be made unless thorough experience with such adjustment has been gained.

The refrigerant vapour from the evaporator coil (bearing the heat from the car interior) is then pulled into the suction side of the compressor, compressed and begins another cycle.

Prevention of the evaporator coil from icing and control of the car interior temperature is obtained by the action of a thermostat in the evaporator assembly which controls a solenoid by-pass valve. The thermostat is located on the left-hand side of the evaporator casing and has a manual setting with seven positions. Normal thermostat setting is position 6. For insufficient cool air flow across the condenser or with the air delivery volume set at a minimum, reduce the manual setting accordingly. In adverse conditions as stated or in the cooler, more humid climates it may be necessary to set the control at 'O'. A capillary tube (bulb) from the thermostat is inserted adjacent to the evaporator coil and is sensitive to the coil temperature. As the thermostat points are 'normally open', reduction of the coil temperature below the predetermined thermostat setting will cause the points to close.



Fig. 3 Evaporator Unit Installed in Boot

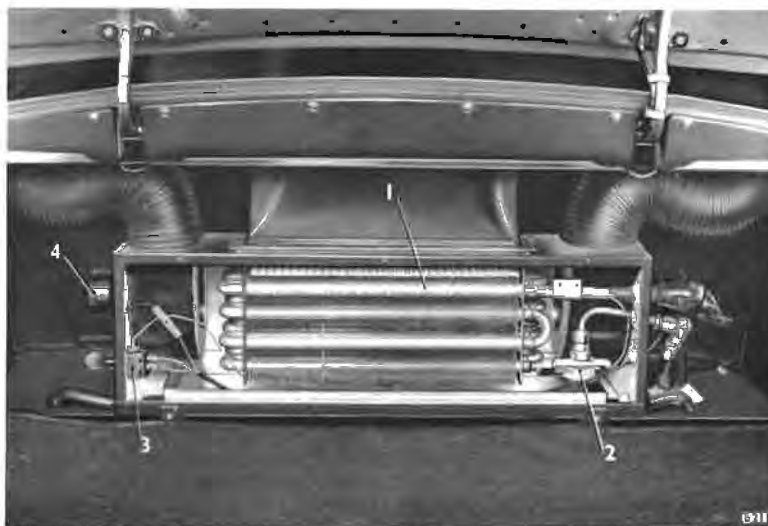

- 1 EVAPORATOR MATRIX
- 2 EXPANSION VALVE
- 3 THERMOSTAT CONTROL SWITCH
- 4 BLOWER MOTOR

Fig. 4 Evaporator Unit with Cover Removed

This creates an electrical circuit to a normally closed solenoid valve coil, causing the valve to open. The valve, located under the bonnet and adjacent to the right-hand valance, is connected to the condenser, and to a 'T' connection on the suction side of the compressor. As the valve opens, high pressure vapour from the condenser is mixed with the low pressure vapour from the evaporator. The resultant

pressure raises the evaporator pressure and correspondingly increases the evaporator temperature. The thermostat is governed for an approximate 5°F. variation at any setting. If the evaporator temperature varies more than 5°F., the thermostat points will open, simultaneously closing the solenoid by-pass valve.

Section C2

OPERATING THE SYSTEM

INTRODUCTION

Two slightly different control switches are fitted to operate the Rolls-Royce Silver Cloud II and Bentley S2 car Air Conditioning (Refrigeration) O.M.C. unit; these are described in detail below. The first description (No. 1) of operation covers the push-button control switch panel located immediately to the left of the steering column (see Fig. 5) which is provided with a centre 'OFF-ON' cancelling button with three buttons on either side, marked LO, MED and HI. Those to the left of the 'OFF-ON' button control the left-hand blower speed and likewise those to the right control the right-hand blower speed.

The second installation (No. 2) is similar except that on the extreme right of the push-button control switch panel is an additional toggle type switch.

TO OPERATE (No. 1 INSTALLATION)

A. Turn the switch marked 'LOWER' (located on

the facia panel) to the *FIRST* position anti-clockwise. (The compressor is now operative and circulates the refrigerant through the system).

B. To Operate both Blower Motors

Select the required blower speed and push 'IN' the respective buttons on the push-button control panel.

C. To Operate One Blower Motor

Push 'IN' the centre 'OFF-ON' button (this cancels all buttons). Push 'IN' the button of the blower and speed desired.

TO OPERATE (No. 2 INSTALLATION)

A. Push 'UP' or 'DOWN' the toggle switch marked 'CLUTCH' (located on the extreme right of the push-button control panel).

B. Blower motor selection and speed desired see B and C of No. 1 INSTALLATION OPERATION.



Fig. 5 Blower Motor Control Panel

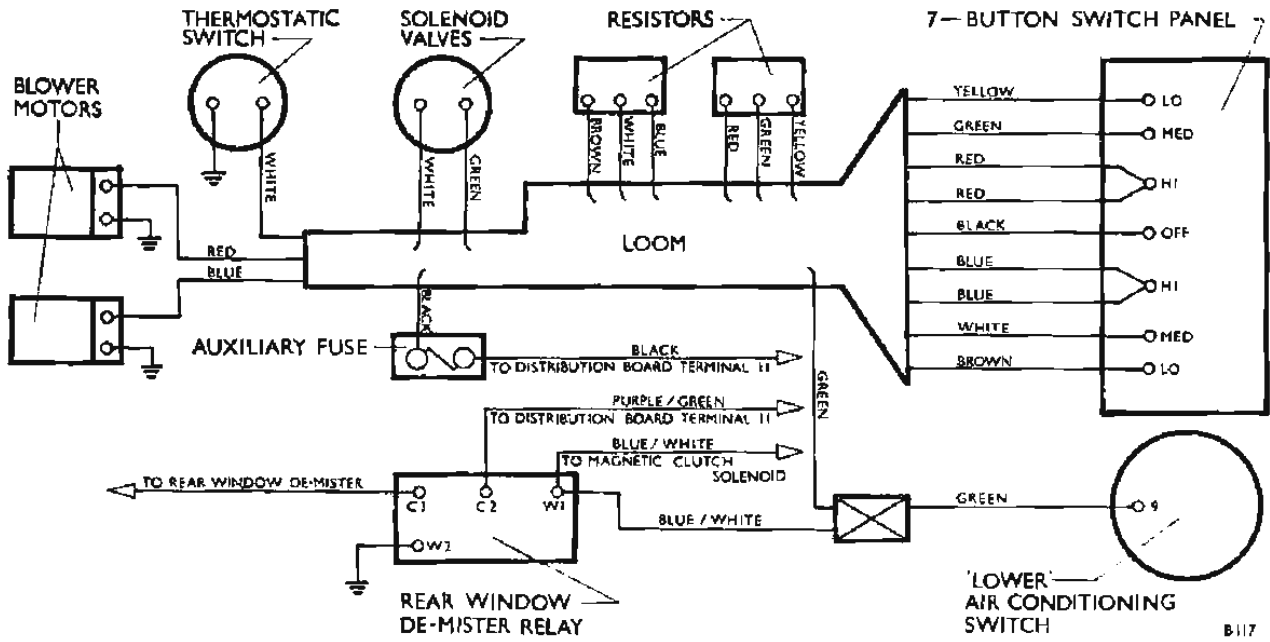

Fig. 6 Wiring Diagram

Section C3**ELECTRICAL COMPONENTS****THE BLOWER MOTOR RESISTANCES**

Two resistance units are incorporated in the circuits for the two blower motors.

The resistances are mounted together on the right-hand side of the bulkhead and secured by screws. The resistance unit mounted to the right is in circuit with the right-hand blower motor.

The resistance consists of a wire coil inside a domed fibre cover. The coil has a centre tapping for medium speed motor operation.

THE BLOWER MOTORS

The twin blower motors are situated at each end of the evaporator casing in the boot. They are identical units and are self-lubricating, thus requiring no attention.

Each motor has a centrifugal drum-shaped aluminium fan which draws air, from the central duct on the parcel shelf, through the evaporator matrix, and discharges through its individual duct in the rear quarter.

The two motors are operated independently by the push-button control panel adjacent to the steering column. Three speeds are made available by the introduction of resistances with centre tappings.

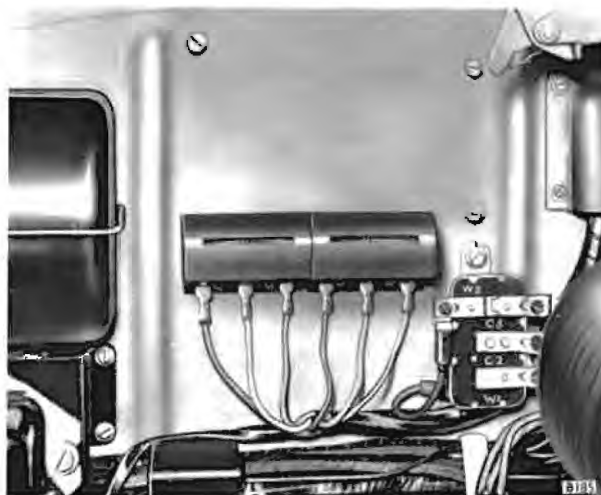

Fig. 7 Blower Motor Resistances

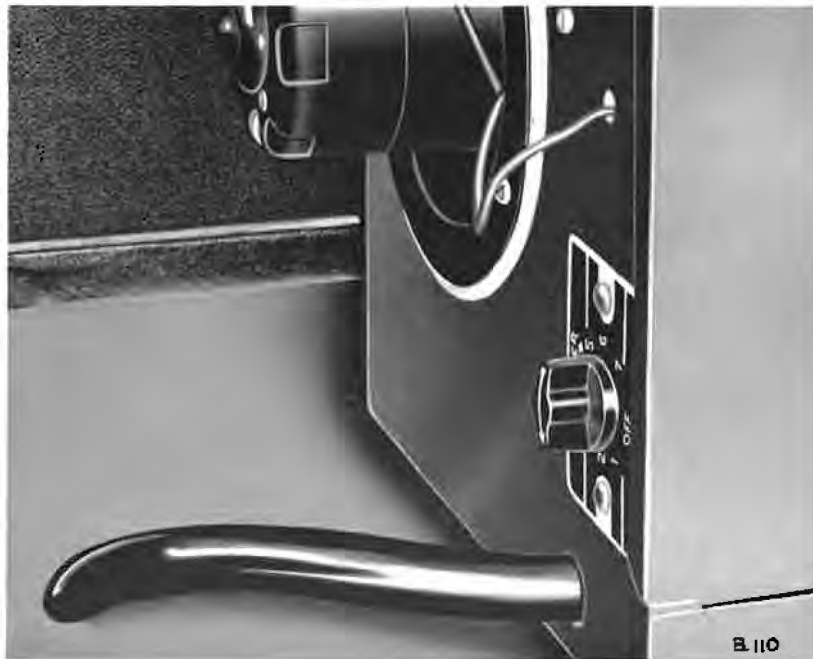

Fig. 8 Thermostat Control Switch

THE THERMOSTAT CONTROL SWITCH

A seven-position switch mounted on the left-hand side of the evaporator casing controls the cut-in temperature of the solenoid by-pass valve.

A capillary tube from the top of the thermostat enters the evaporator matrix, making the thermostat sensitive to the temperature of the cooled air. Adjustment of the switch position varies the point at which the solenoid valve will open and cycle the compressor. This prevents too low a temperature in the evaporator matrix, which could cause icing of the fins and reduced airflow.

An internal adjustment screw is provided for initial setting of the switch temperature range. This must be set to the required range (given below) when a replacement switch is fitted; no further adjustment should be necessary. **WARNING.** The switch knob should never be placed in the 'OFF' position when the system is operating as this could cause damage to the solenoid valve and the compressor.

The approximate minimum temperatures corresponding to the seven operating positions are as follows:—

1	2	3	4	5	6	7
42 -40 F	40 -38 F	38 -36 F	36 -34 F	34 -32 F	32 -30 F	30 -28 F

THE BY-PASS SOLENOID VALVE

Model—Danfoss EVJD-6 (Stamped FXM or FXMW on the valve body).

The solenoid valve is mounted midway along the right-hand valance and is connected in the by-pass line between the compressor intake pipe and the condenser. Operation of the valve is governed by a thermostatic switch controlled by a phial in the evaporator matrix.

The purpose of this valve is to control the degree of cooling, preventing icing of the evaporator, and to maintain a minimum pressure of 2 lb/sq. in. on the low pressure side of the system. To maintain this pressure, high pressure vapour from the condenser is passed through the valve and reintroduced to the suction side of the compressor. This also prevents too heavy a pressure drop in the compressor crankcase, which could cause priming of the oil.

The construction of the valve is shown in Figure 9.

The lower end of the moving core has a rubber insert which seats against a nozzle protruding upwards from the body of the valve. When the circuit is open, the core seat is held against the nozzle by a spring-loaded plunger which is situated in the core so as to extend from the upper face and contact the blind end of the solenoid bore (see Fig. 9).

When the coil is energised the core is drawn upwards and the refrigerant flows through two small holes in the rubber diaphragm which mounts the nozzle, leaving via the nozzle orifice.

Since the total area of the two inlet holes in the diaphragm is less than the area of the nozzle orifice, the resultant pressure drop in the chamber causes the diaphragm to lift from its seating, allowing the refrigerant to flow from the annular inlet groove, under the diaphragm, to the outlet port, thus by-passing the two inlet holes and the nozzle orifice and permitting full flow.

A leak from the valve casing will probably be due to inefficient sealing; renew the rubber 'O' ring between the valve body and the valve chamber cover, refit the cover and tighten the six retaining screws.

A leaking valve may be caused either by a faulty diaphragm or a damaged core rubber insert.



B 104

- | | | | |
|---|--|---|----------------------|
| 1 | RETAINING SCREW | 5 | SECURING SCREWS |
| 2 | IDENTIFICATION PLATE
(FITTED TO EARLY
TYPE ONLY) | 6 | MOVING CORE |
| 3 | SOLENOID AND CASING | 7 | DIAPHRAGM AND NOZZLE |
| 4 | VALVE CHAMBER COVER | 8 | SEALING RING |
| | | 9 | VALVE BODY |

Fig. 9 By-pass Solenoid Valve

THE REAR WINDOW DE-MISTER RELAY

In order to prevent heavy loading of the battery, resulting from the refrigeration system and the rear window de-mister unit working in opposition, a relay is incorporated in the system to break the circuit for the rear window de-mister whenever refrigerated air is being passed into the car.

The relay is mounted on the upper right-hand side of the bulkhead.

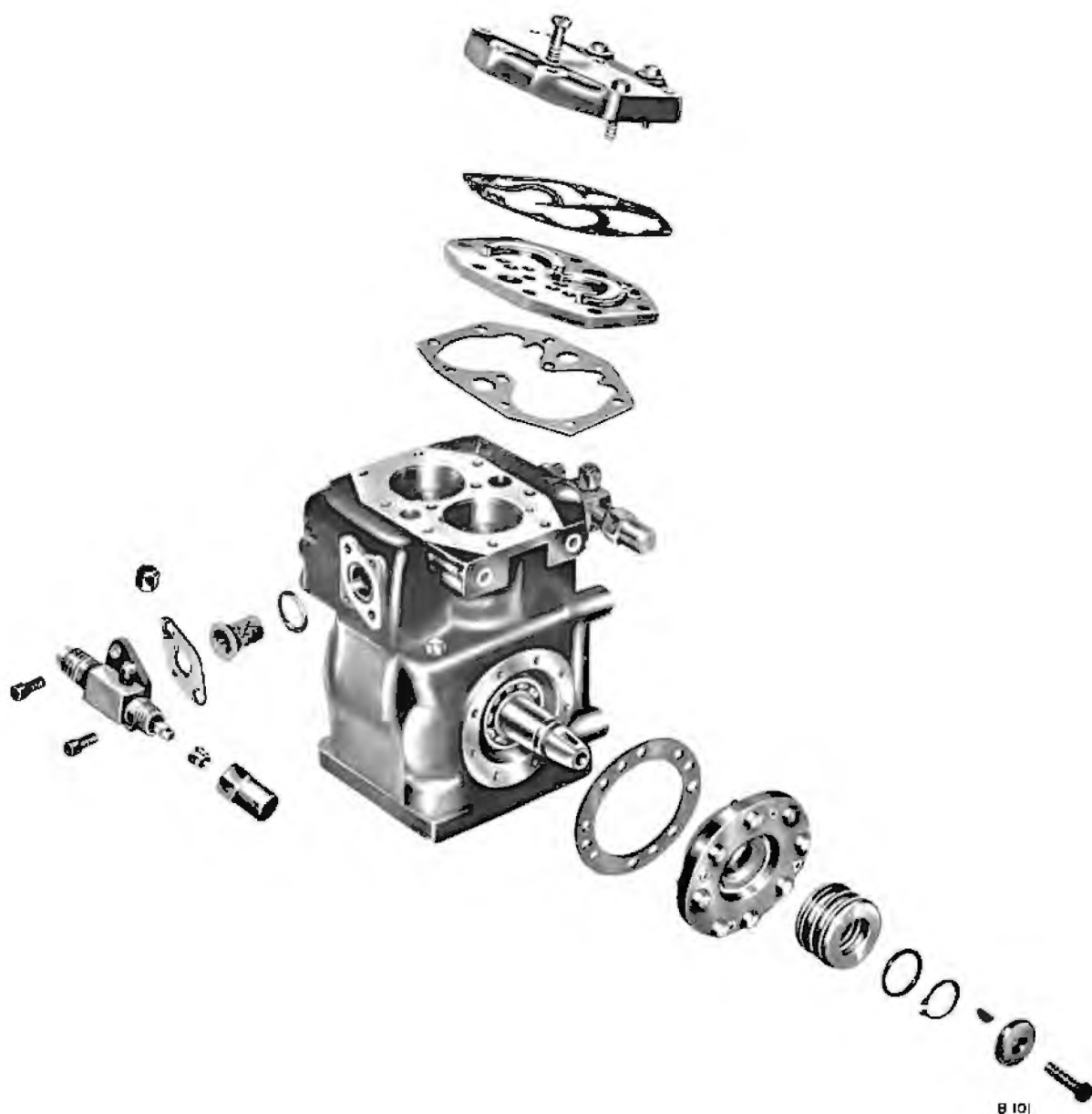

B 101

Fig. 10 Tecumseh Compressor—Exploded View

Section C4

THE COMPRESSOR, CONTROL VALVES AND ANCILLARY UNITS

THE COMPRESSOR

The compressor used in conjunction with the O.M.C. unit is either the Tecumseh HH vertical twin cylinder unit, with an Eaton Electromagnetic clutch (see Fig. 2), or the York A.209 with an Electro Lock Inc. clutch.

Replacement units are readily available and it is not recommended that any major overhaul work be attempted, except by the manufacturers. The valve plate, oil seal and clutch bearing may be renewed as necessary.

FAULT DIAGNOSIS

When carrying out pressure tests, a low reading on the high pressure side indicates an inoperative valve or defective gasket. To confirm the diagnosis, reduce the engine speed to 'slow idle' and turn the compressor low pressure service valve clockwise to the forward-seated position. The compound gauge should register 12 in. to 18 in. Hg. almost immediately if the intake valve is satisfactory.

Switch off and observe the gauge readings. A leaking shaft seal will permit a rise to atmospheric pressure. A rise above atmospheric pressure indicates a defective gasket, or that the delivery valve is not seating correctly.

Before disturbing any compressor joint, close the service valves to seal off the system, and release the pressure from the head as described for the oil level check.

When the cylinder head is removed, examine the valves and cylinder bores. A damaged valve will necessitate changing the valve plate assembly; where a cylinder bore is badly scored, a replacement compressor must be fitted.

When re-assembling, clean all joint faces carefully and immerse the new gaskets in clean refrigerant oil before fitting.

COMPRESSOR UNIT—TO REMOVE AND FIT
To Remove

Remove the magnetic clutch.

Forward-seat both compressor service valves and release the compressor pressure, as described for the

oil level check. Release the screws securing the service valves to the compressor. Remove the gauze filter from the compressor inlet port (also the fibre washer on Tecumseh units).

Unscrew the four compressor securing setscrews situated beneath the compressor mounting bracket and remove the compressor unit, leaving the service valves connected to the pipes.

To Fit

When fitting the compressor, secure all connections, then purge the air and turn both service valves anti-clockwise until fully back-seated.

Test for leaks under operating conditions and static conditions. Install the gauge set, check the pressures and ensure that the complete system is functioning correctly.

MAGNETIC CLUTCH-COMPRESSOR

The Eaton Clutch, as Fitted to the Tecumseh HH

The clutch consists of an electromagnetic flywheel driven by twin 'Vee' belts from the engine, and a drive plate attached by a flexible coupling plate to the forward end of the compressor crankshaft.

The flywheel is constantly driven by the engine and when the circuit is open, idles on a single bearing carried on the drive plate shaft. When the circuit is closed, current to energise the electromagnet is conveyed through two carbon brushes mounted on the compressor body and two copper collector rings attached to the inner face of the flywheel. The electromagnet attracts the drive plate which is fitted with a fibre friction facing to take up the drive to the compressor.

Eaton Clutch—To Remove

Remove the single retaining bolt and withdraw the flywheel and drive plate assembly from the crankshaft. Care should be exercised when removing the assembly to ensure that the brushes are not damaged.

Remove the retaining circlip and withdraw the drive plate. Inspect the plate for wear of the fibre facing and for cracked springs or loss of tension; renew the plate if necessary. Examine the bearing for wear and clean the collector rings.



Fig. 11 Eaton Magnetic Clutch

Re-assemble the clutch and set the air gap between the two drive faces by means of the three adjusting screws in the drive plate. The gap should be 0.025 in. to 0.035 in.

Examine the brushes for wear and renew the brush unit if necessary. Failure of the clutch may be due to the presence of grease or oil on the collector rings and brushes. This should be removed with a cloth moistened with petrol and the unit assembled and tested.

The Electro Lock Magnetic Clutch as Fitted to the York A.209

This clutch differs from the Eaton clutch in that the solenoid does not rotate with the flywheel but is secured to the compressor crankcase and thus remains stationary. The stationary solenoid design eliminates the necessity for feed brushes and collector rings and reduces servicing to the provision of lubrication for the bearings on which the clutch rotates.

Electro Lock Clutch—To Remove

Remove the central retaining bolt and washer from the compressor crankshaft; insert a $\frac{5}{8}$ in. UNC. bolt into the bore of the clutch. Screw in the bolt just far enough to free the clutch from the crankshaft, then withdraw the clutch and remove the bolt.

Extract the spring ring from the clutch shaft and withdraw the shaft and driving plate. Inspect the

drive springs and nylon spigots, also the fibre facing in the annular groove in the driving plate.

Check that the bearings in the pulley are adequately lubricated and rotate freely without roughness or wear.

Shaft Seal—Tecumseh HH—To Renew

With the clutch assembly removed from the compressor, press in the sealing ring seat and extract the circlip to permit withdrawal of the seal assembly.

Remove any roughness from the shaft surface by lightly stoning, then coat all parts with refrigerant oil before re-assembling.

Shaft Seal—York A.209—To Renew

REMOVAL

Remove the flywheel or clutch and the woodruff key from the compressor shaft.

Remove the seal plate capscrews and washers and gently pry the seal plate loose, taking care not to mar or scratch the flat sealing surfaces or the polished shaft surface. When removing the seal plate, the hand should be held under the seal housing to catch the carbon ring if it is free.

Do not pry or force the carbon ring with a hard sharp object in such a manner as to damage the

carbon ring. In some cases it may be bonded to the retainer.

Remove the seal assembly from the shaft by prying behind the drive ring which is that portion of the seal assembly farthest back on the shaft. When prying the seal assembly from the shaft, do not scratch the crankshaft or the sealing housing face on the crankcase.

All parts should be cleaned prior to re-assembly.

INSTALLATION

Check the front face of the crankshaft front bearing journal in the seal housing, to make certain that the two seal drive pins are in place. These two drive pins are located 180° apart on the front bearing journal face.

Wash all portions of the seal assembly in clean refrigerant oil.

Push the seal assembly, less the carbon ring, if it is free, over the end of the shaft, with the carbon ring retainer facing out. Move the assembly along the shaft a few times to ensure a good seal between the neoprene ring and the shaft. Push the seal assembly all the way on the shaft making sure the slots in the seal drive ring engage the drive pins on the shaft bearing journal face.

If the carbon ring is separate, place it in the ring retainer so that the polished surface is facing out. The carbon ring must engage the driving lugs and be fully seated in the ring retainer.

Place a very light film of clean refrigerant oil on the matching metal faces where the seal plate gasket is to be placed. Place the seal plate gasket, dry, in position on the seal housing face.



Fig. 12 York Compressor in Position

Place the seal face plate in position with the polished portion facing the carbon ring and insert the capscrews with the washers. Turn in the capscrews evenly while rotating the shaft, making sure there is even clearance between the shaft and shaft hole in the face plate. If clearance is not the same all around the shaft, gently tap the seal face plate into position until there is equal clearance. After equal clearance is obtained, tighten all the capscrews by tightening diagonally opposite capscrews evenly to the required 90 lb. in. torque.

LUBRICANTS

The following proprietary lubricants are approved for use in the Tecumseh HH and York A.209 compressors:—

	MOBIL	CASTROL	SHELL
TECUMSEH HH	GARGOYLE ARCTIC 155	ICEMATIC HEAVY	CLAVUS 33
YORK A.209	REGENT TEXACO CAPELLA E		

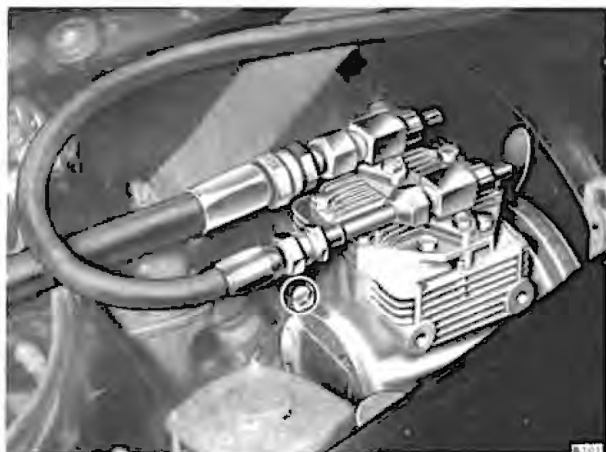

Fig. 13 Filler Plug—York Compressor

New compressors are supplied dehydrated and containing the correct quantity of oil. When a new compressor is installed, it is possible that some oil will remain in the system, therefore the oil level must be checked and if necessary adjusted.

The oil level must also be checked when any refrigerant is extracted from the system.

The correct oil depth in the Tecumseh compressor, when checked by a dipstick, is between $1\frac{1}{8}$ in. and $1\frac{1}{2}$ in. The correct oil depth in the York A.209 is $1\frac{1}{4}$ in.

Oil Level—to Check

Run the engine at fast idle with the refrigeration system operating, until the compressor is fully warmed (approximately 10 minutes) to ensure that no liquid refrigerant remains in the compressor crankcase. Forward-seat the low pressure service valve, run the engine for a further minute and switch off. Forward-seat the high pressure service valve immediately.

Do not operate the compressor with the high pressure valve closed.

Carefully slacken the gauge attachment cap nut on each service valve to release the gas pressure from the head, then re-tighten. Thoroughly clean and dry the area around the oil filler plug and slowly remove the plug so as to gradually release the gas pressure from the crankcase.

When releasing gas pressures, protective goggles must be worn to prevent any possibility of refrigerant coming into contact with the eyes.

Measure the oil depth using a dry, clean rod approximately $\frac{1}{8}$ in. diameter. It may be found necessary to rotate the compressor slowly by hand to allow the 'dipstick' to pass the crank balance weights.

Adjust the oil level by means of a syringe, adding or drawing-off oil as necessary. Refit the filler plug loosely; do not tighten the plug as it is necessary to purge the air from the compressor.

NOTE: It is recommended that oil be used only from a sealed container.

To Purge the Air from the Compressor

Slacken the protective cap on the high pressure service valve. Open the low pressure service valve very slightly and allow gas to pass through the compressor for about ten seconds. Whilst the gas is still passing, tighten the oil filler plug and then the valve cap nut.

Back-seat both service valves and refit the protective caps.



Fig. 14 Condenser Matrix

CONDENSER

The condenser matrix is situated between the radiator matrix and the intake grille (see Fig. 14). Its purpose is to cool refrigerant gas delivered by the compressor and condense it; the liquid refrigerant then passes into the receiver.

The matrix comprises two banks, each of sixteen horizontal tubes. A single inlet pipe conveys compressed refrigerant to a 'Tee' junction at the head of the matrix. This junction supplies the two banks independently. At the base of the matrix another junction connects them to the single outlet.

A by-pass pipe to the solenoid valve permits high pressure vapour to flow back to the suction side of the compressor when the valve is open.

THE RECEIVER

The receiver is a steel container of welded construction, secured by three bolts to a bracket forward of the frame front cross-member (see Fig. 15).

The inlet pipe union is situated at the top of the container; the outlet union is positioned midway down the right-hand end-face. Inside the receiver, a pipe attached to the outlet union bends downward to the base of the unit in order to ensure that liquid refrigerant only will pass to the drier.

A fusible plug, inserted at the base of the unit, prevents explosion in the event of fire. *Under no circumstances must this be replaced by a solid plug.*



1 SIGHT GLASS
2 RECEIVER
3 DRIER

Fig. 15 Drier, Receiver and Sight Glass

THE DRIER

The drier unit is mounted below the right-hand front apron (see Fig. 15), and has a sight glass attached to the elbow at the outlet end.

The drier unit consists of a steel tubular shell fitted with flared connections at the inlet and outlet.



Fig. 16 Compressor and Refrigerant Lines

Screwed into the inlet port is a metal gauze filter to prevent the ingress of coarse impurities and to protect the dehydration charge, which is granulated Silica-gel. At the outlet end, a felt pad, retained by a perforated metal plate, prevents the ingress of fine impurities.

The drier unit and the dehydration charge should be renewed alternately at intervals of 10,000 miles, i.e., after 10,000 miles, renew the unit; after 20,000 miles, renew the charge only.

The charge must also be renewed if for any reason the system is opened to remove a faulty unit.

To remove the unit, release the pipe union at each end of the shell.

To renew the charge, remove the union situated at the inlet end, clean the gauze filter and check to ensure that the felt filter is not obstructed. Extract the spent charge and replace by a fresh quantity of Silica-gel.

Section C5**MAINTENANCE**

The complete system should be checked every six months for correct operation and topped-up with refrigerant as necessary, particularly after periods of non-use of the Air Conditioning System during winter months.

EVERY 5,000 MILES

1. Check the tension of the compressor driving belts. A 6 lb. load applied at the mid-point of the drive-side run of either belt should cause a deflection of $\frac{3}{8}$ in.

2. Using compressed air, thoroughly clean the condenser matrix fins of all foreign matter.

STORAGE

The operation of the system should be checked before use after storage as loss of refrigerant can ensue due to leakage past seals.

SAFETY DEVICE

A fusible plug is inserted in the receiver to prevent explosion in the event of fire. Under no circumstances must this be replaced by a solid plug.

Section C6

SERVICING

The following special tools are available and can be ordered through Rolls-Royce and Bentley distributors, if required.

Part No.	Description	Off.			
RH.531	Wrench, Ring, 1.125 in. A/F × .875 in. A/F	1	RH.530	Thermometer	1
RH.532	Wrench, Ring, .750 in. A/F × 1.000 in. A/F	1	RH.529	Spring Balance, 0-25 lbs.	1
RH.533	Wrench, Ratchet, .250 in. square ..	1	RH.527	'Blaydon' Leak Detector Lamp, or Similar Model	1
RH.538	Manifold Gauge Set, Assembly ..	1	RH.528	Tube Flaring Tool	1
			RH.534	Tube Cutting Tool	1
			RH.669	Filter	1
				Goggles, Pair	
				Kit, First Aid, containing medicated liquid paraffin and saline wash.	

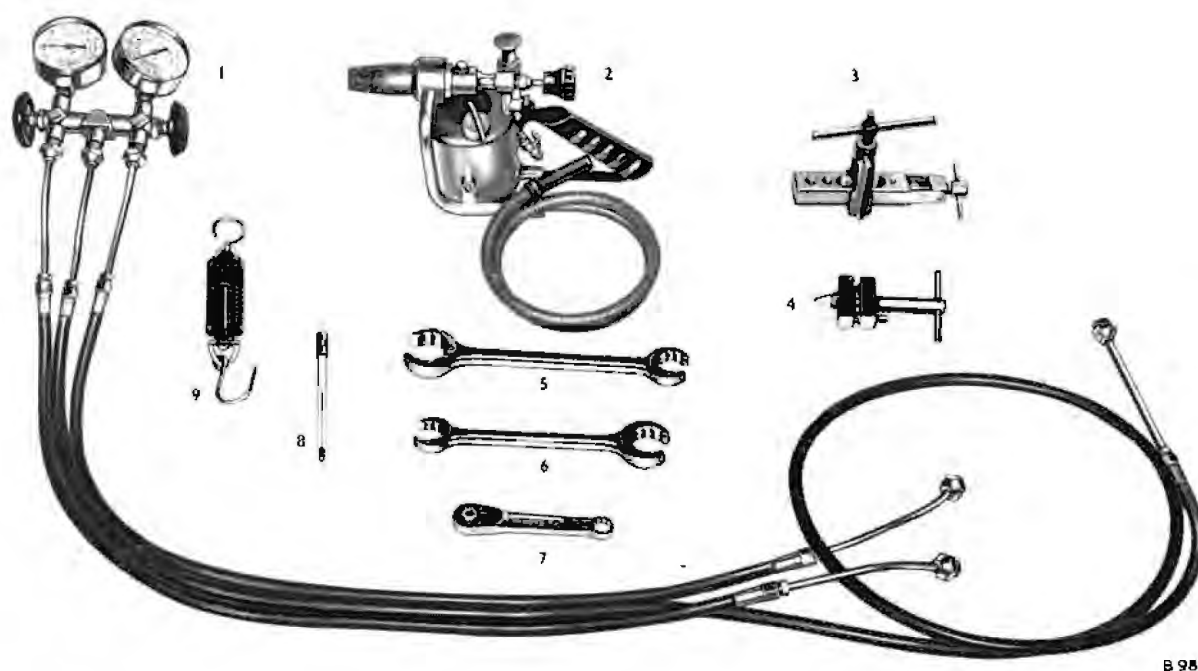

- | | | | |
|---|--------------------|---|--------------------------------------|
| 1 | MANIFOLD GAUGE SET | 5 | SPANNER 1.125 in. A/F x .875 in. A/F |
| 2 | LEAK DETECTOR LAMP | 6 | SPANNER 1.000 in. A/F x .750 in. A/F |
| 3 | TUBE FLARING TOOL | 7 | RATCHET WRENCH .250 in. SQUARE |
| 4 | TUBE CUTTING TOOL | 8 | THERMOMETER |
| | | 9 | SPRING BALANCE |

Fig. 17 Service Tools

PRECAUTIONS TO BE OBSERVED WHEN HANDLING REFRIGERANT

Exposure to Refrigerant

Large quantities of refrigerant gas discharged into a confined space will displace the oxygen in the air and could cause suffocation.

Liquid refrigerant which may accidentally escape is at least 20°F. below zero and, if allowed to come into contact with the skin, it can cause a burn by the rapid transference of heat from the skin to the liquid as it evaporates. Serious damage to the eyes will result from contact with liquid refrigerant. For this reason, goggles should always be worn when contact might be possible.

Should liquid refrigerant come into contact with the eye, *immediate First Aid is necessary* and a doctor or eye specialist should be consulted as soon as possible.

First Aid Treatment

Medicated liquid paraffin from the First Aid Kit should be applied to the eye from an eye dropper, to wash away the Freon. The eye should not be rubbed, as this will increase the area of injury. If the eye remains painful after a few minutes, the wash should be repeated, using a sterile salt solution containing not more than 2% sodium chloride.

The Importance of Chemical Stability

The efficient operation of the system is dependent upon the Pressure-Saturation Temperature Relationship of pure Freon 12. So long as the system contains only pure Freon 12 (plus a certain amount of compressor lubricant which mixes with the Freon), it is considered to be chemically stable.

When foreign materials such as dirt, air or moisture are allowed to enter the system, they will affect chemical stability, change the Pressure-Saturation Temperature Relationship of the Freon, and possibly cause freezing up of the expansion valve. Thus, the system will no longer operate at the correct pressures and temperatures, with a consequent decrease in efficiency.

The Sealing of Components

Whenever it becomes necessary to break a refrigerant connection, the exposed ends should be immediately capped. Air entering the system will carry moisture, which collects quickly on any exposed

surface, causing deterioration, owing to the acidic properties of an air-Freon compound.

FAULT LOCATION

For the purpose of complaint diagnosis, the system falls into two groups.

1. **Air Circulation**
2. **Refrigerant Circulation**

AIR CIRCULATION

Switch on and check air delivery at the duct outlets. Check over the full range of blower speeds.

A failure on one side only would be due to either a defective blower on that side or a defective connection between the push-button switch and the blower motor.

A failure in one switch position only would be due to a defective switch.

A complete failure indicates a fuse, switch or wiring defect.

REFRIGERANT CIRCULATION

Initial Checks

Site the car in a well ventilated and shaded area. Check the belt tension and the external cleanliness of the condenser, as detailed under 'MAINTENANCE'.

Start the engine and warm-up at a fast idle, operating the Air Conditioning system with the blowers full on. Visually check that the magnetic clutch is operating.

Observe the sight glass located adjacent to the filter drier (this is either located adjacent to the receiver or in some instances adjacent to the evaporator assembly). If bubbles or foam appear in the sight glass, the refrigerant is low. Also, a distinct continuous or intermittent hiss from the expansion valve in the boot indicates that vapour is being passed through the valve and that the refrigerant charge is low. In either case check the system for leaks. (See Section on Leak Detection).

Ice formation adjacent to the compressor intake is an indication of excessive delivery through the expansion valve, this can be caused by a faulty expansion valve.

A partial blockage will create a drop in temperature at the point of restriction in a hot vapour or liquid line, or across the receiver or filter-drier assembly, and this will be obvious to the touch.

PRESSURE TESTS

Before taking readings, the car should be sighted in a well-ventilated position to ensure an adequate flow of air over the condenser. It is advisable to place a fan in front of the radiator for additional air flow over the condenser if the system is to be operated over a long period. Check the security of the radiator cap, after topping-up the coolant level as necessary. The 'blow-off' pressure is 7 lb/sq. in. and the pressure relief valve is located under the detachable plate on top of the radiator header tank, or is incorporated in the filler cap.

Switch OFF and install the manifold gauge set on the compressor valve service ports with both its valves firmly closed. Remove the protection caps from the compressor service valves and just crack open both valves by rotating one half turn in a clockwise direction.

During these tests, it is essential that the compressor service valves are not fully opened, as this closes the system delivery and damage to the compressor and lines could occur.

Run the engine at a fast idle with the Air Conditioning system operating as previously mentioned.

Turn the compressor service valves ANTI-CLOCKWISE as necessary to damp out gauge fluctuation.

The compound gauge reading should be 15-30 lb/sq. in.

With the following ambient air temperatures (temperature recorded in the shade), the pressure gauge reading should be as follows:

60°F (15.6°C)	100—150 lb/sq. in.
80°F (26.7°C)	140—190 lb/sq. in.
100°F (37.8°C)	180—240 lb/sq. in.
110°F (43.3°C)	215—270 lb/sq. in.

N.B.—The maximum reading for each of the above temperatures would only apply if very little air flow is allowed to pass over the condenser.

DIAGNOSIS

Set the compressor valves $\frac{1}{2}$ a turn clockwise from the fully anti-clockwise position.

A low reading on the high pressure gauge coupled with a high reading on the compound gauge, indicates a defective compressor head gasket or valve plate gasket or a defective valve. (See Section—Valve Plate and Gaskets).

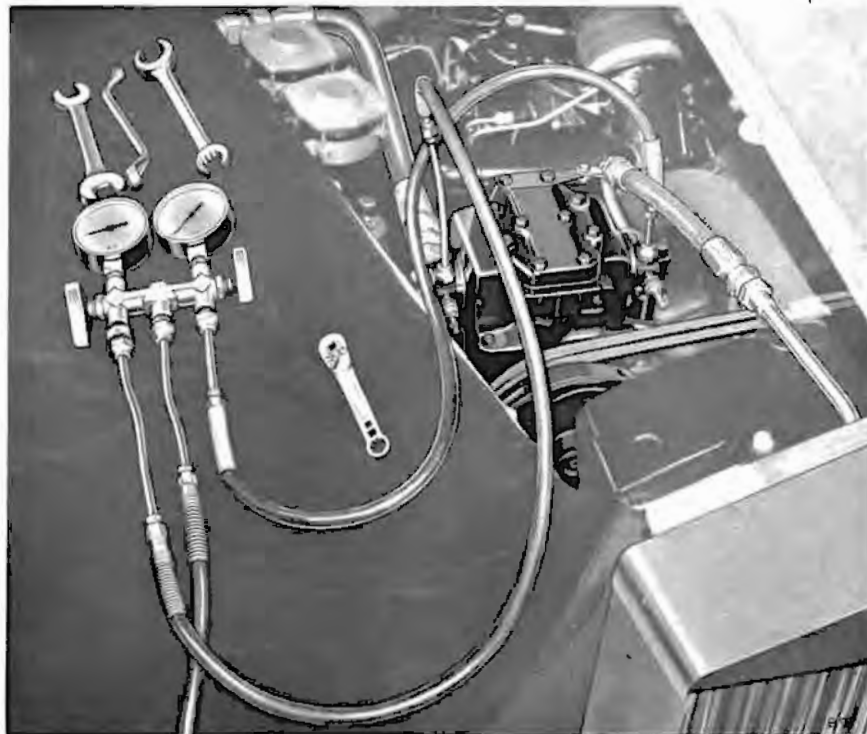
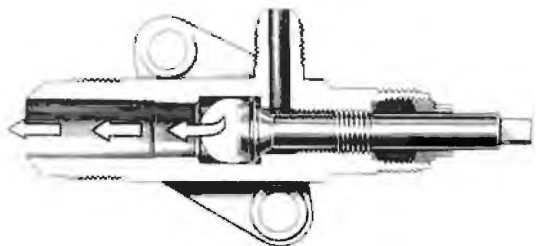

Fig. 18 Manifold Gauge Set in position



B94

Fig. 19 Service Valve—Backward seated

An unusually low reading of the compound gauge indicates:

- A low refrigerant charge.
- A very light heat load condition.
- A partial restriction in the expansion valve.
- A low expansion valve power element charge.
- A defective expansion valve.
- An evaporator coil blocked by ice.

A high reading of the compound gauge indicates:

- An excessive refrigerant charge.
- An unusually high heat load condition such as car windows lowered or heating system operative.
- Poor contact of the expansion valve power element with the evaporator coil outlet.
- A defective expansion valve.
- An open solenoid by-pass valve.

An unusually low reading of the high pressure gauge indicates:

- An open solenoid by-pass valve.

An unusually high reading of the high pressure gauge indicates:

- An excessive refrigerant charge.
- A restriction in the high pressure side.
- An unusually high heat load condition.
- Insufficient air passing over the condenser.
- An unusually hot-running engine.
- Air or non-condensable gases in the system.

An instantaneous high reading of the high pressure gauge and subsequent unusually low reading of this

gauge, coupled with a low reading of the compound gauge indicates a restriction in the expansion valve port such as internal icing condition or a blocked expansion valve screen.

SUPERHEAT TEST

The system may be checked for correct operation as follows:

Attach a glass thermometer to the suction pipe from the evaporator so that it is near the expansion valve bulb. Cover the thermometer bulb and pipe with cloth to provide insulation from atmospheric temperature, leaving the scale visible. Operate the engine at a fast idle with the Air Conditioning system operating (full on) and leave running for a few minutes. Read the thermometer, and the compound gauge at the compressor. Add 3 lb/sq. in. to the gauge reading to compensate for pressure drop in the suction line.

Refer to the following table to obtain the saturation temperature corresponding to this pressure and subtract this figure from the thermometer reading. The result should lie between 8-15°F. This is termed the 'Superheat Reading'.

Pressure—Saturation Temperature
relationship table—Freon 12

Pressure lb/sq. in.	Temperature °F	Pressure lb/sq. in.	Temperature °F
20	19.5	35	38
21	21	36	39
22	22	37	40
23	23.5	38	41
24	24.5	39	42
25	25.5	40	43.5
26	27	41	44.5
27	28.5	42	45.5
28	29.5	43	46.5
29	31	44	47.5
30	32.5	45	48.5
31	33.5	46	49.5
32	34.5	47	50.5
33	36	48	51.5
34	37	49	52.5
		50	53

Where correct compound and high pressure gauge readings are obtained, any complaint of inefficiency

can only be attributed to lack of air delivery. Check for operation and ensure that inlet and outlet ducts are unobstructed. A slightly low compound gauge reading would be observed if there were any obstructions causing a lack of air delivery.

DISCHARGING REFRIGERANT

When it is necessary to break any joint which is not protected by service valves, the refrigerant must first be discharged.

Do not discharge in an area where an open flame is exposed. The refrigerant does not burn, but decomposes and forms a poisonous gas.

Remove the protective caps from the compressor service valves. Just 'crack' the high pressure valve in a clockwise direction, allowing the refrigerant in the system to be discharged to atmosphere. Care must be taken not to release the refrigerant too quickly, as this will result in oil being drawn out of the system. The operation should take at least fifteen minutes.

Always use two wrenches in opposition when disconnecting flared connections, to prevent damage to flares or tubes. The tubes are easily twisted.

After the necessary repair has been made and before re-charging, it is necessary to evacuate and sweep the system, to remove all the moisture. The compressor oil level should be checked, as detailed under 'Compressor'.

EVACUATING

The use of a vacuum pump is recommended for evacuation but when not available the compressor may be utilised as follows:

Fit the manifold gauge unit to the compressor as illustrated. Forward-seat the high pressure service valve of the compressor by rotating it in a clockwise direction to the end of its travel. Open the pressure valve of the manifold gauge set by rotating it in an anti-clockwise direction fully.

Close the vacuum valve of the manifold gauge set by rotating it in a clockwise direction. Just 'crack' the low pressure service valve by giving half a turn in a clockwise direction.

Start the engine and run on 'slow idle'. Switch on the blowers in the 'HI' position. Observe the vacuum

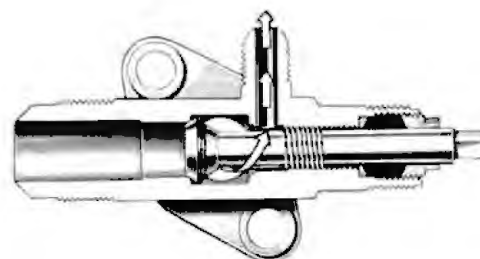

B 95

Fig. 20 Service Valve—Forward seated

gauge and when a reading of 28 inches Hg. is reached, or when the maximum possible vacuum that can be obtained from the prevalent barometric conditions is reached; allow the compressor to continue drawing a vacuum for a further 15 minutes, then close the pressure valve on the manifold gauge set. Immediately switch off the ignition. The system must also be evacuated for a full 15 minutes when a vacuum pump is utilised.

Switch off the engine. If the system loses vacuum quickly, a leak is prevalent. If the system loses vacuum extremely slowly a leak is possible. In this condition, it is advisable to further evacuate for 45 minutes to eliminate the possibility of residual liquid Freon in the compressor oil vaporising and creating a pressure rise in the system. The final vacuum reading obtained should be held for 30 minutes to ascertain that no leaks are present. (To check the system for leaks, see under Leak Detection).

SWEEPING

It is recommended that the filter drier assembly be renewed if the system has been open to atmosphere for any considerable length of time or if the diagnosis procedure outlined in this manual indicates the presence of moisture in the system.

Back-seat the high pressure service valve by turning anti-clockwise to the end of its travel. Forward-seat the low pressure service valve by turning in the clockwise direction. Connect the centre union of the manifold gauge set to a Freon 12 container. Close both valves on the manifold gauge set by turning in a clockwise direction.

Open the valve of the Freon 12 container. Break the manifold centre hose joint, purge the air for a

few seconds and then re-tighten. Hook a spring balance to the container and record the weight.

Open the vacuum valve of the manifold gauge set and allow approximately one pound of gas to pass into the evacuated system. In some cases one pound of gas will not flow into the system, so allow the amount to pass into the system which will balance the system pressure with the Freon 12 container pressure. Allow the dry Freon introduced into the system to remain for a period of 10 minutes. Do not allow the pressure reading on the compound gauge to exceed 50 lb/sq. in. This can be controlled by regulating the manifold gauge set vacuum valve. Switch off the system and switch off the ignition.

Purge the Freon in the system by introducing an additional Freon charge as follows:

Remove the manifold gauge set from the compressor service valves, set the service valves to their midway position to allow the Freon remaining in the system to escape to atmosphere. Connect the hose of the high pressure gauge to the discharge service port of the compressor. With the manifold gauge set connected to the Freon container, the compound gauge valve closed and the high pressure gauge valve open, allow Freon from the container to pass into the discharge service port, through the service port, through the condenser, filter drier, evaporator and out through the service port of the suction (service) valve. Allow this operation to continue for approximately five seconds.

CHARGING

It is necessary to draw out the remainder of the refrigerant put in during the sweeping operation before charging fully. Repeat the evacuation process and switch off.

Back-seat the high pressure service valve and forward-seat the low pressure service valve. Reconnect the centre union of the manifold gauge set with the refrigerant container, and open the valve on the container. Break the manifold centre hose joint and purge the air for a few seconds, then re-tighten.

Hook a spring balance to the refrigerant container

and record the weight. Open the vacuum valve of the manifold gauge set.

Start the engine and switch on the blowers. If the refrigerant will not flow into the system even with the compressor in operation stand the container in a bucket of warm water not exceeding 113°F. Do not apply a flame, or localised heat. This could cause an explosion. Do not allow the reading on the compound gauge to exceed 50 lb/sq. in. This can be controlled by regulating the manifold gauge set vacuum valve.

When 3½-4 lbs. refrigerant has been drawn into the system, switch off and close the manifold gauge set vacuum valve.

Close the valve of the Freon 12 container and disconnect the centre hose. Back-seat both service valves on the compressor. Disconnect and remove the manifold gauge set and replace protective covers on service valves. Check the system for leaks, using a detector lamp.

LEAK DETECTION

Leak detection should be carried out at full operating pressure (see under pressure tests for appropriate figures) and under static conditions by means of the Detector Lamp. In order to obtain the correct pressure, it may be necessary to re-charge the system.

Light the detector lamp and move the open end of the flexible hose round all points where leaks are possible. The colour of the lamp flame will change to green when the open end passes over a leak point.

It is important not to operate the lamp pressure pump while in the vicinity of possible leaks because refrigerant will be drawn into the body of the lamp and the flame will thus remain green for some time, and be unusable as a leak detector.

Furthermore, the car should be placed in a position where there is adequate ventilation, otherwise refrigerant may persist in the vicinity of the car and give misleading results; however, draughts should not be prevalent or the seepage of gas in a particular area of a possible leak could dissipate without detection. (An alcohol leak detector may be used similarly as above).