



EB410.2

BUILDING
INSTRUCTIONS

INTRODUCTION



Thank you for purchasing the Tekno RC EB410.2 10th 4WD competition electric buggy kit. We are always working on new projects, so please check our website regularly at www.teknorc.com or visit us on Facebook at www.facebook.com/teknorc for all the latest news, parts, and kits.

Take your time! When you work your way through these building instructions, keep an eye out for the following important indicators below:

- **RED TEXT** - *This indicates important areas of the build process that should be observed.*



Thread Lock icons

Thread lock is always used when a screw is inserted into any metal part. (Included with kit)



Grease icons

Grease is usually used on areas with movement and for sealing. (Included with kit)

- **YOUTUBE** - *We also have many useful build videos on Youtube, so be sure to check these out!*
<https://www.youtube.com/c/teknorc>

Additional equipment and parts needed:

- 2 Channel radio and receiver
- 1/10th scale ESC and motor system
- Low profile or standard size high torque steering servo (at least 180 oz/in)
** Running less than the recommended rating will increase the chance of premature servo failure.*
- 2S (2 cell, 7.4v) shorty LiPo battery
- Paint for body
- 1/10th scale 4x4 buggy wheels & tires, CA glue (or premounts)
- 48 pitch pinion 15 tooth - 30 tooth

Tools needed:

- Hex drivers 1.5mm, 2.0mm, 2.5mm
- Nut drivers 5.5mm (TKR1108), 7.0mm (TKR1109)
- Hobby knife
- Needle-nose pliers
- Shock tool (TKR1115) OR adjustable (Crescent) wrench (for shock assembly)
- 4mm turnbuckle wrench (TKR1103) AND 5.5/7.0 two sided wrench (TKR1119)
- Body reamer

Disclaimer: Tekno RC is not responsible or liable for any property or personal damage, loss, or injury incurred as a result of using this product. This kit is meant for use by persons 14 years of age or older and in the strict confines of a legally permitted RC track or facility.

Warnings: Always double-check that your radio gear is working properly before operating vehicle. Never operate the vehicle indoors (unless the RC track is an indoor facility). Use caution while operating vehicle so as not to collide with people who may be turn marshalling or who might otherwise not be aware that a fast moving RC vehicle is in the vicinity.

Warranty: We warrant that the parts included in this kit are free from defects. If you find a defective part in your kit, please contact us at info@teknorc.com and we will help to resolve the issue. If you modify any part prior to contacting us, the warranty claim will be void. We do not warranty parts that may be broken during operation of the vehicle or otherwise. Refer to the end of this instruction manual for a listing of spare/replacement and option parts. All spare parts and other info are available on our website (www.teknorc.com) and through our network of domestic and international dealers and distributors.

Bag A

Center Differential (overview)

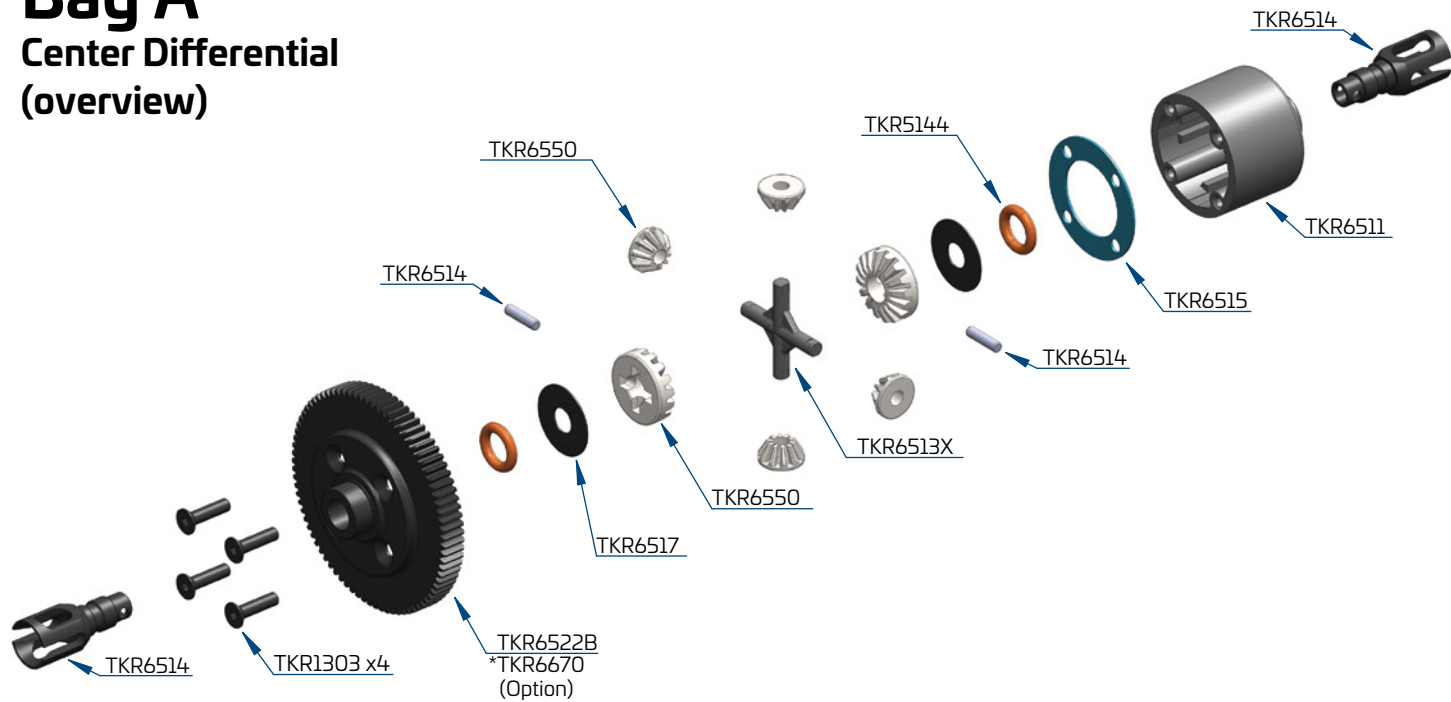

Step A-1



Step A-2

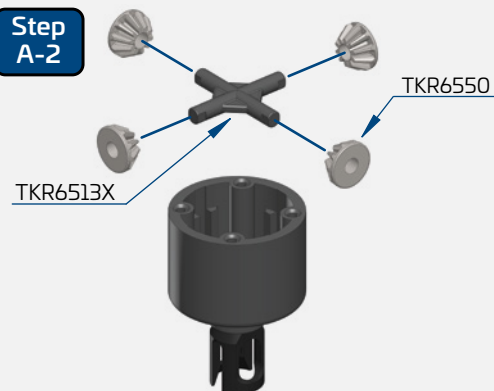

Step A-4



Step A-3



x4
TKR1303
M2.5x10mm Flat Head Screw

x2
TKR5144
Differential O-rings

x2
TKR6517
Differential Shims (5x14mm)

Bag C

Steering/Bulkhead Assembly

Step C-1

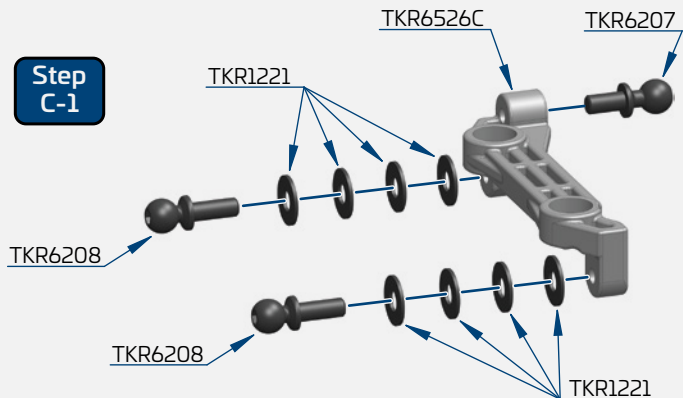

Step C-2

* Thread Lock

Note: Use a 5.5mm wrench (TKR1119) here to assist in tightening this assembly.

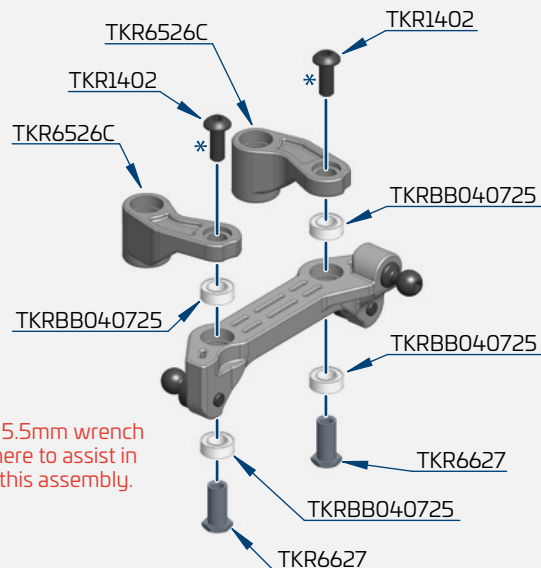

Step C-3

* Thread Lock

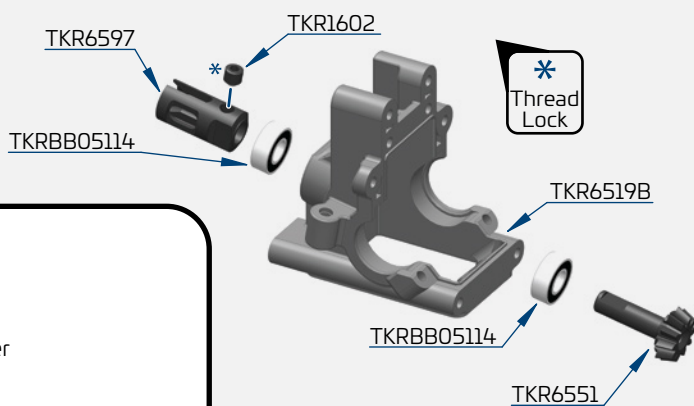

Step C-4

Note: Use a 2mm hex to pre-thread the steering posts into the bulkhead.

This will ensure that the posts go in as straight as possible. After pre-threading, remove the posts and re-install them with the entire steering assembly as shown.

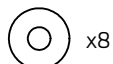
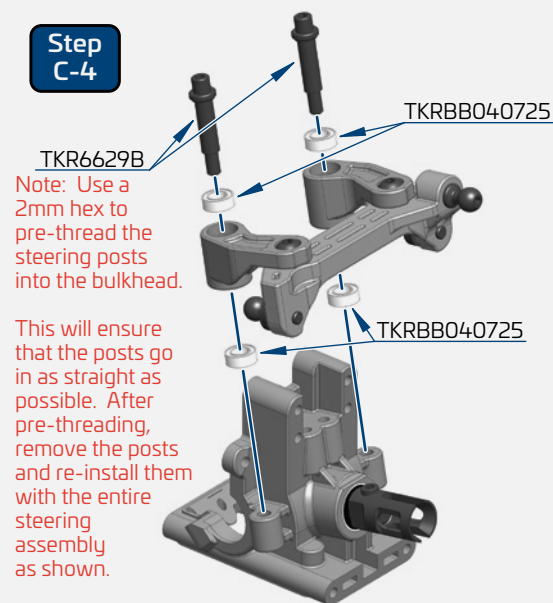

x8

TKR1221
M3x8mm Washer



x2

TKR1301
M2.5x6mm Flat Head Screw



x4

TKR1402
M3x8mm Button Head Screw



x1

TKR1602
M4x4mm Set Screw



x4

TKRBB040725
Ball Bearing (4x7x2.5)



x2

TKRBB05114
Ball Bearing (5x11x4)



x2

TKRBB10154
Ball Bearing (10x15x4)

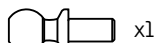

x1

TKR6207
M3x6mm Ball Stud

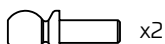

x2

TKR6208
M3x8mm Ball Stud

Step C-5

Grease

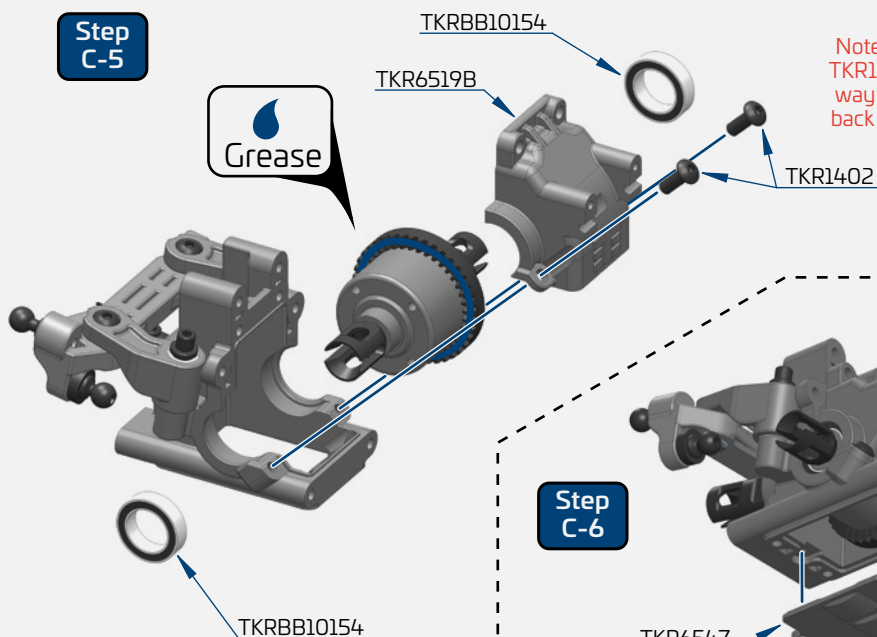

Note: Screw the TKR1402's all the way down, then back off 1/4 turn.

Step C-6

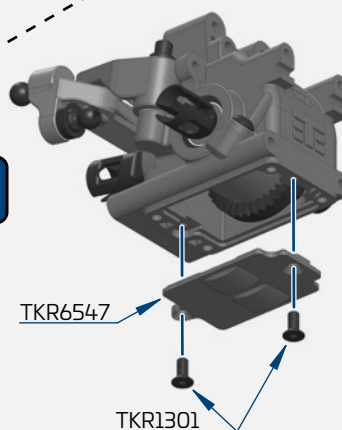

5

Bag D

Rear Bulkhead Assembly

Step
D-1

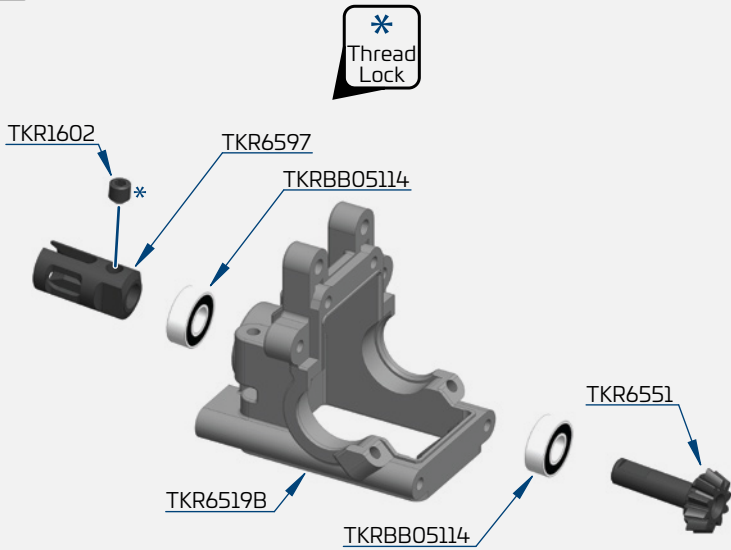

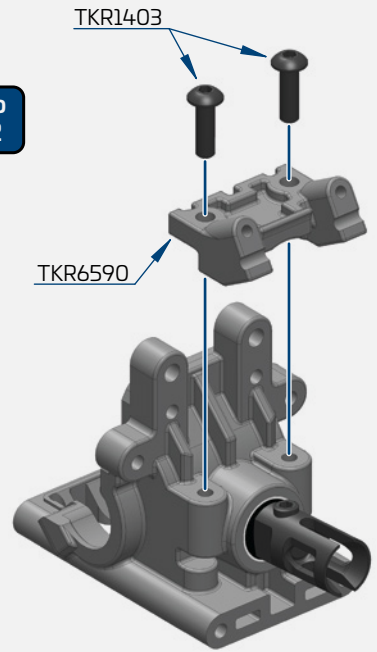

Step
D-2



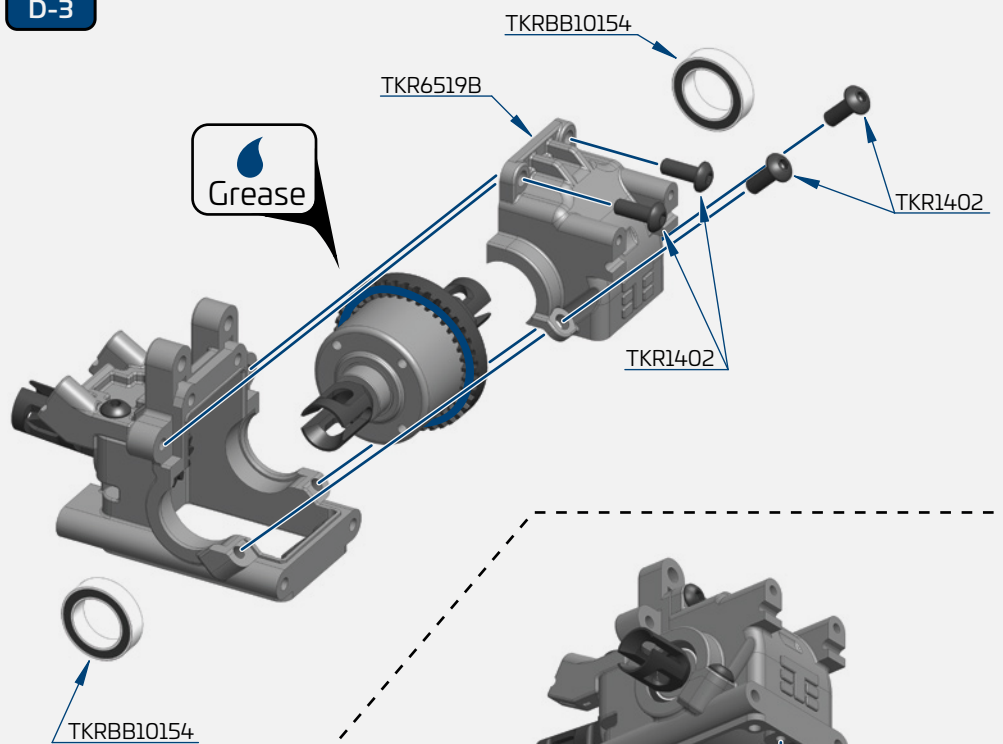

Step
D-3

Note: Screw the TKR1402's all the way down, then back off 1/4 turn.



 x2
TKR1301
M2.5x6mm Flat Head Screw

 x4
TKR1402
M3x8mm Button Head Screw

 x4
TKR1403
M3x10mm Button Head Screw

 x1
TKR1602
M4x4mm Set Screw

 x2
TKRBB05114
Ball Bearing (5x11x4)

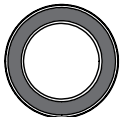
 x2
TKRBB10154
Ball Bearing (10x15x4)

Step
D-4

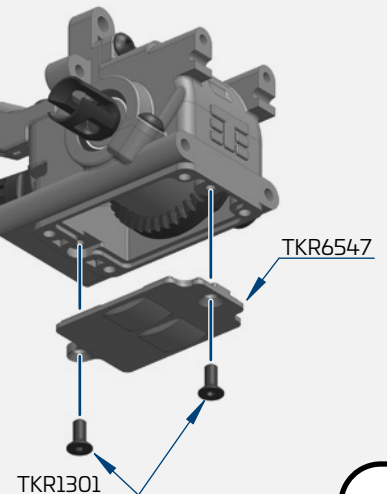

Bag E

Rear End Assembly

Step E-1

TKR6610 - 1.7mm
 Below options sold separately.
 *TKR6610 - 1.5mm
 *TKR6610 - 1.6mm
 *TKR6610 - 1.8mm
 *TKR6610 - 1.9mm
 (Option)

TKR1601
 Note: Do not over-tighten.

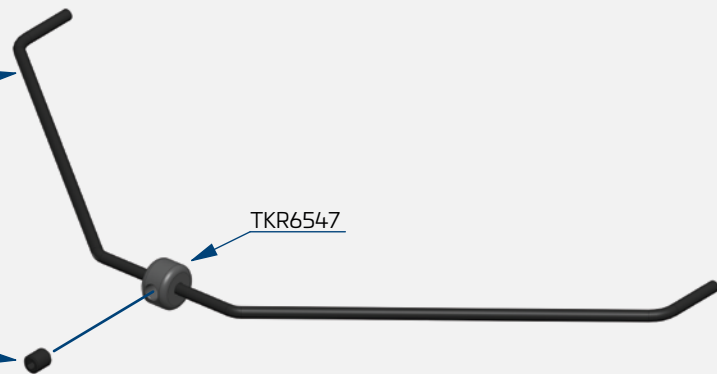

Step E-2

Note: Screw these set screws in gently, until they just touch the sway bar, then back off just slightly so the sway bar is free.

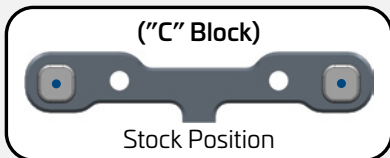
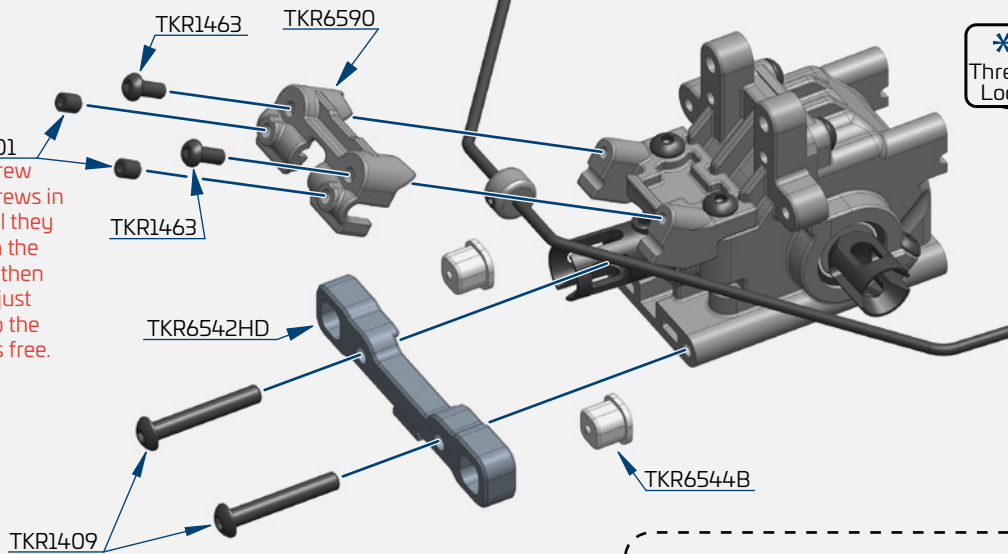

Note: With center dot inserts, Anti-Squat = 2°

* Thread Lock

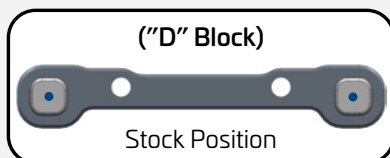
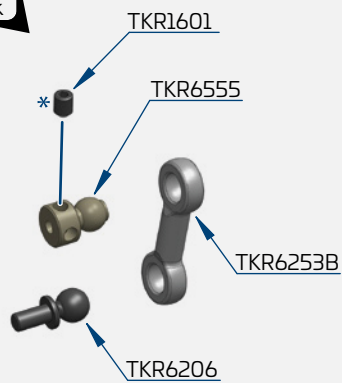

Note: With center dot inserts, Rear Toe = 2°

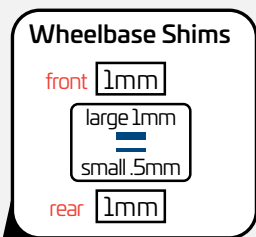

Step E-3

x2
 TKR1405
 M3x14mm Button Head Screw

x2
 TKR1409
 M3x20mm Button Head Screw

x2
 TKR1463
 M2.5x6mm Button Head Screw

x5
 TKR1601
 M3x4mm Set Screw

x2
 TKR1611
 M4x8mm Set Screw

x2
 TKR6206
 M3x6mm Ball Stud

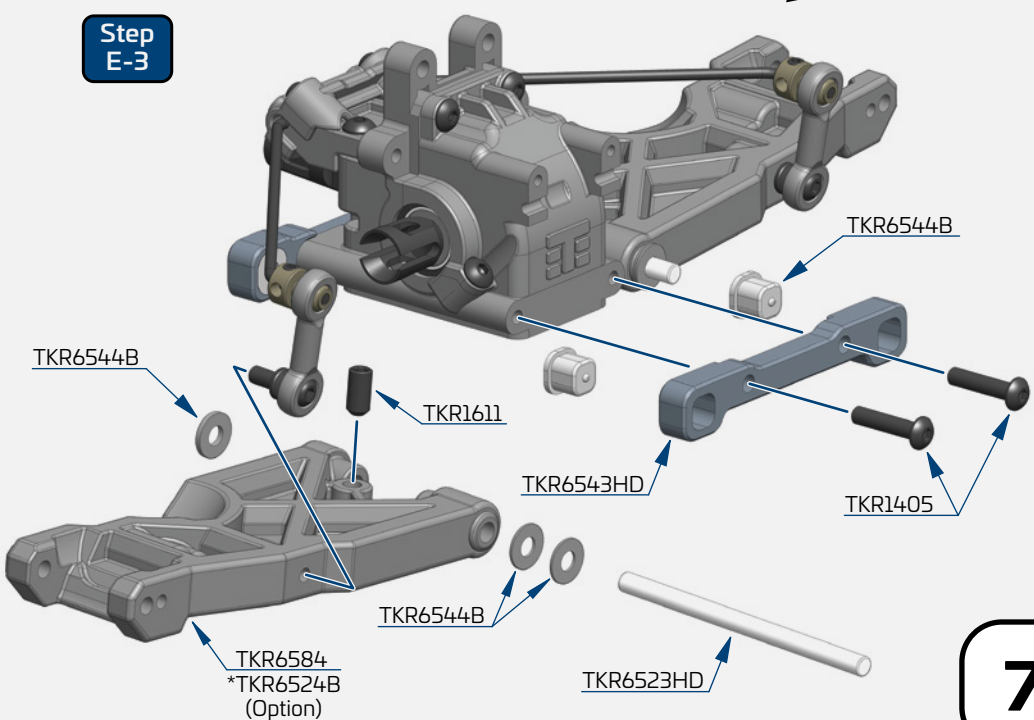

Bag F

Rear Hub/CVA Assembly



Step F-1

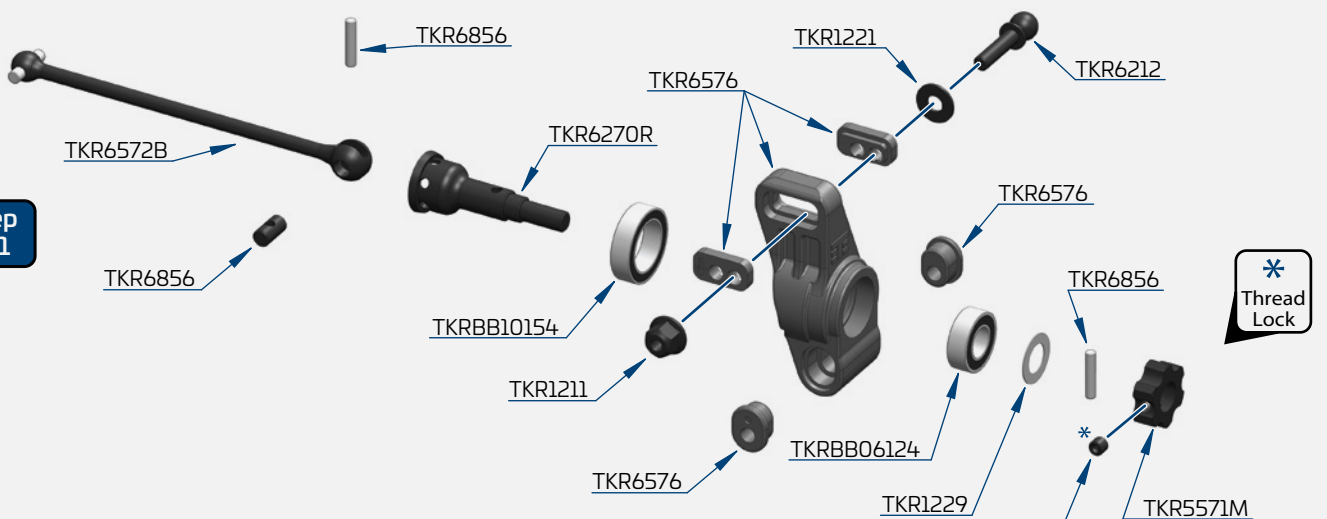

* Thread Lock

Note: These screws only need to be snug. Do not over-tighten.

HUB INSERTS

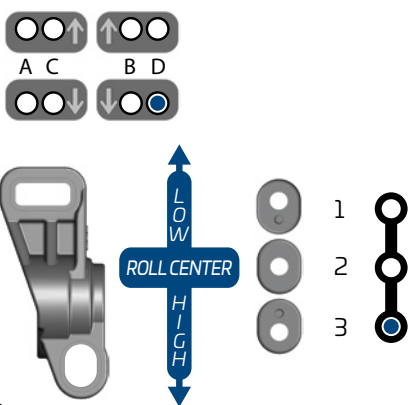

TOP VIEW HUB ORIENTATION

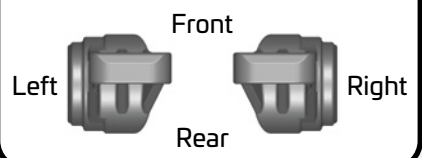

x2
TKR1211
M3 Lock Nut Flange Black

x2
TKR1221
M3x8mm Washer

x2
TKR1229
6x10x0.2mm Shim

x2
TKR1400
M3x4mm Button Head Screw

x2
TKR1609
M3x3mm Set Screw

x2
TKRBB06124
Ball Bearing (6x12x4)

x2
TKRBB10154
Ball Bearing (10x15x4)

x2
TKR6212
M3x12mm Ball Stud

Step F-2

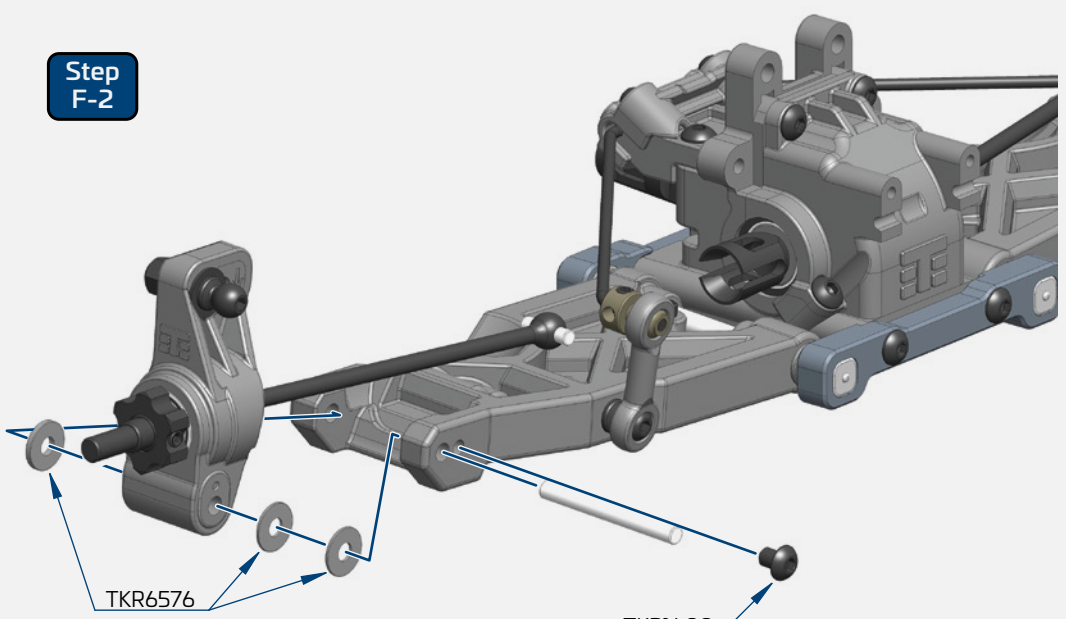

Note: These screws only need to be snug. Do not over-tighten.

Bag F

Rear Camber Links

Step F-3

Build Tip: Use some grease or Chapstick on the threads to help prevent "pop-off" when adjustments are being made.

Build Note: Hold the turnbuckle stationary with pliers and push the rod end hard onto the turnbuckle while turning at the same time. Keep in mind that one end of the turnbuckle has normal threads and the other has reverse threads. Start the rod end straight and it will thread on straight.



Left/Right x 2pcs

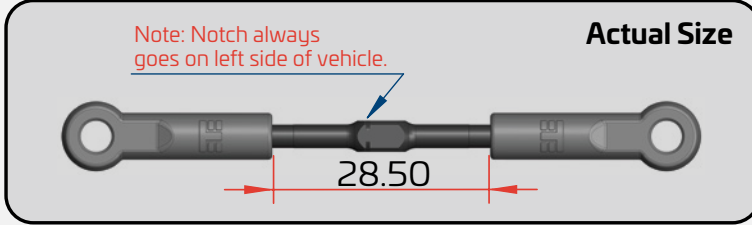

Step F-4

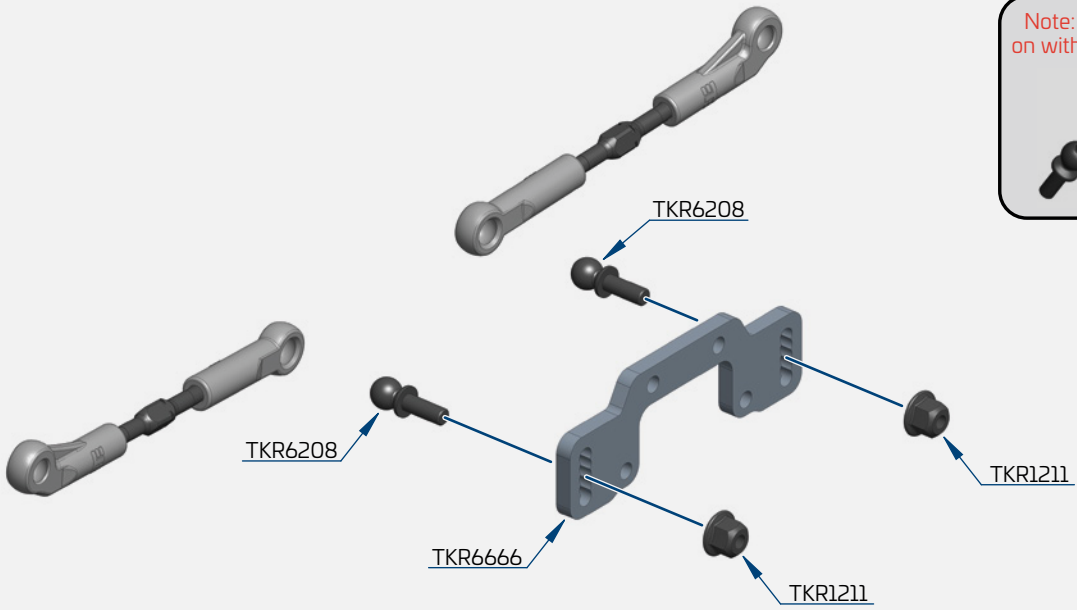

Step F-5

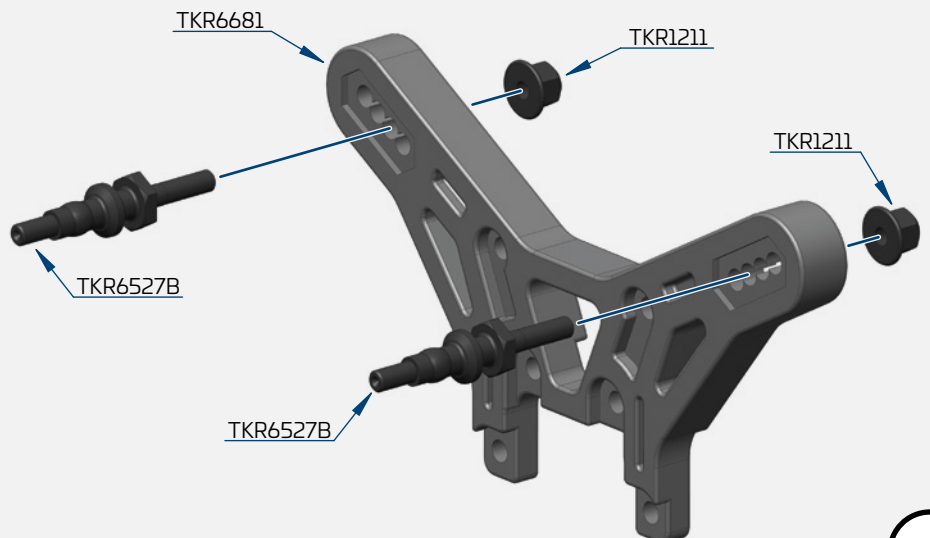

x4
TKR1211
M3 Lock Nut Flange Black

x2
TKR6208
M3x8mm Ball Stud

Bag F

Rear Tower/Wing Mount

Step
F-6

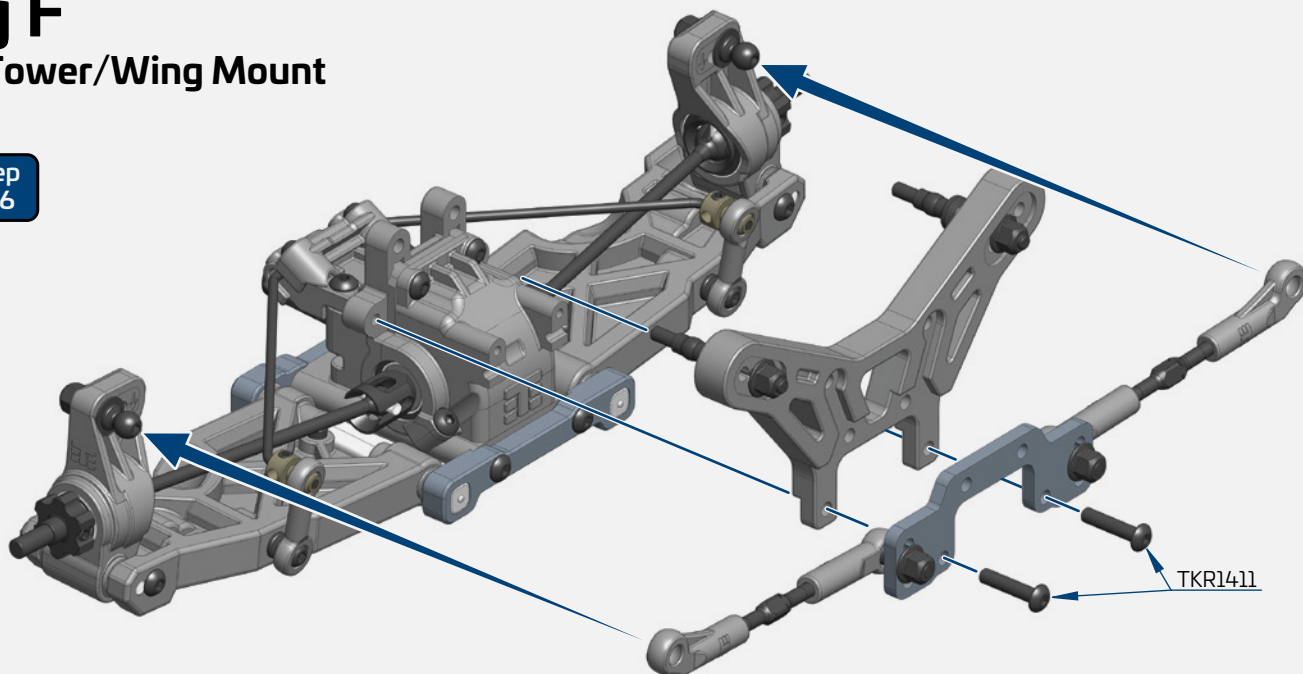

Step
F-7

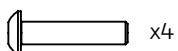
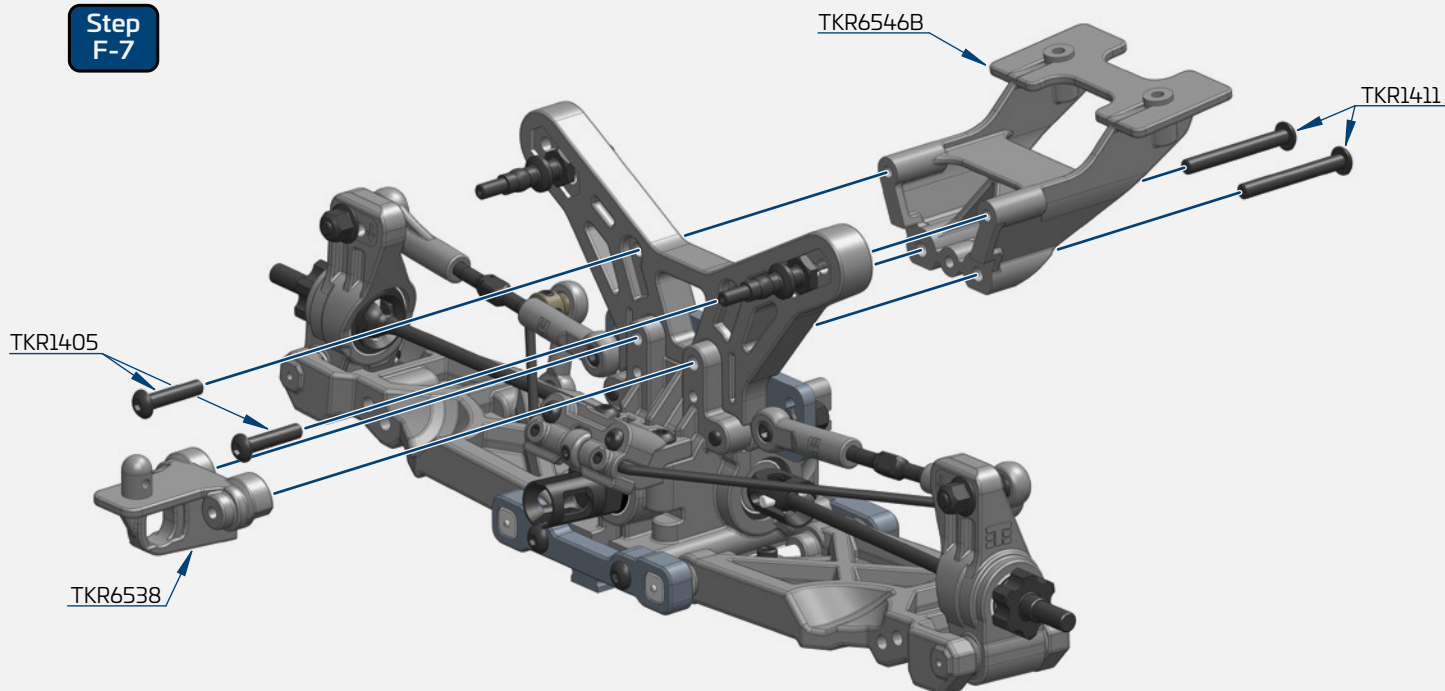

x4
TKR1405
M3x14mm Button Head Screw

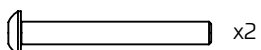

x2
TKR1411
M3x25mm Button Head Screw

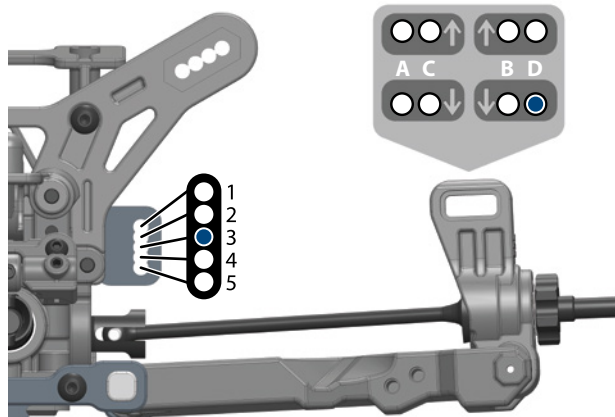

Stock position is 3/D

Bag G Front End Assembly

Step G-1

TKR6611 - 1.4mm
Below options sold separately.
*TKR6611 - 1.0mm
*TKR6611 - 1.1mm
*TKR6611 - 1.2mm
*TKR6611 - 1.3mm
(Option)

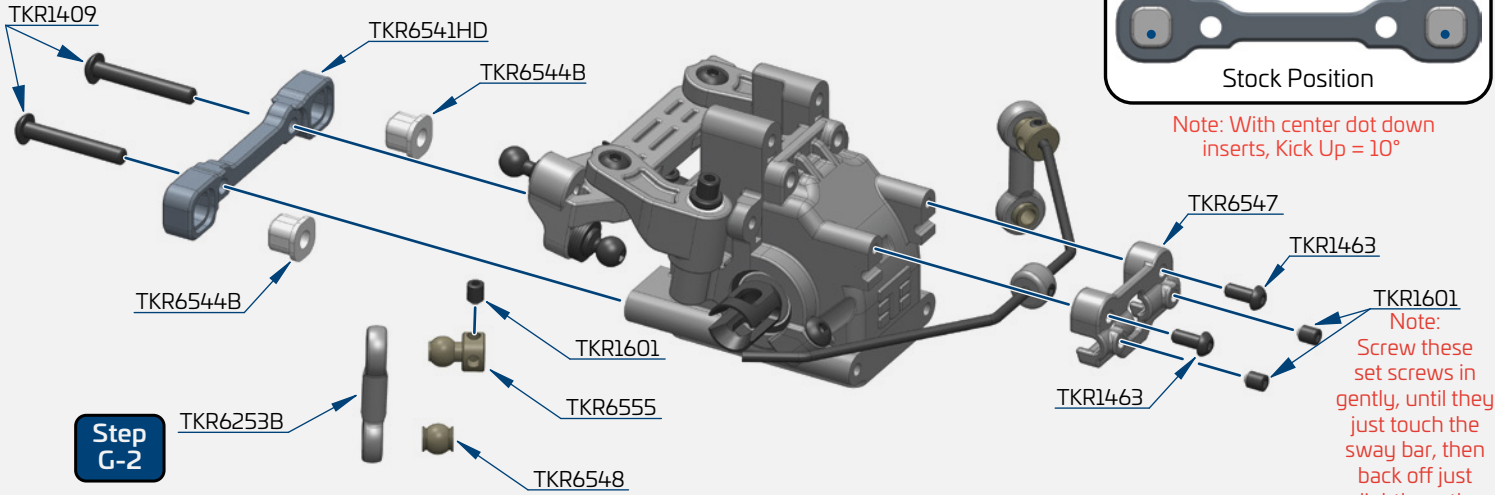
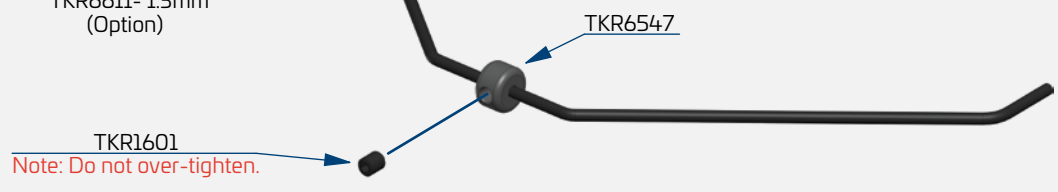

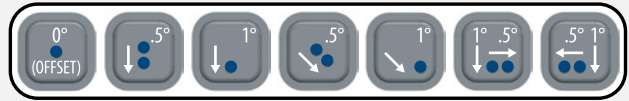
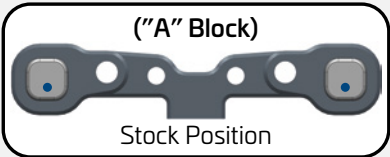

Step G-2

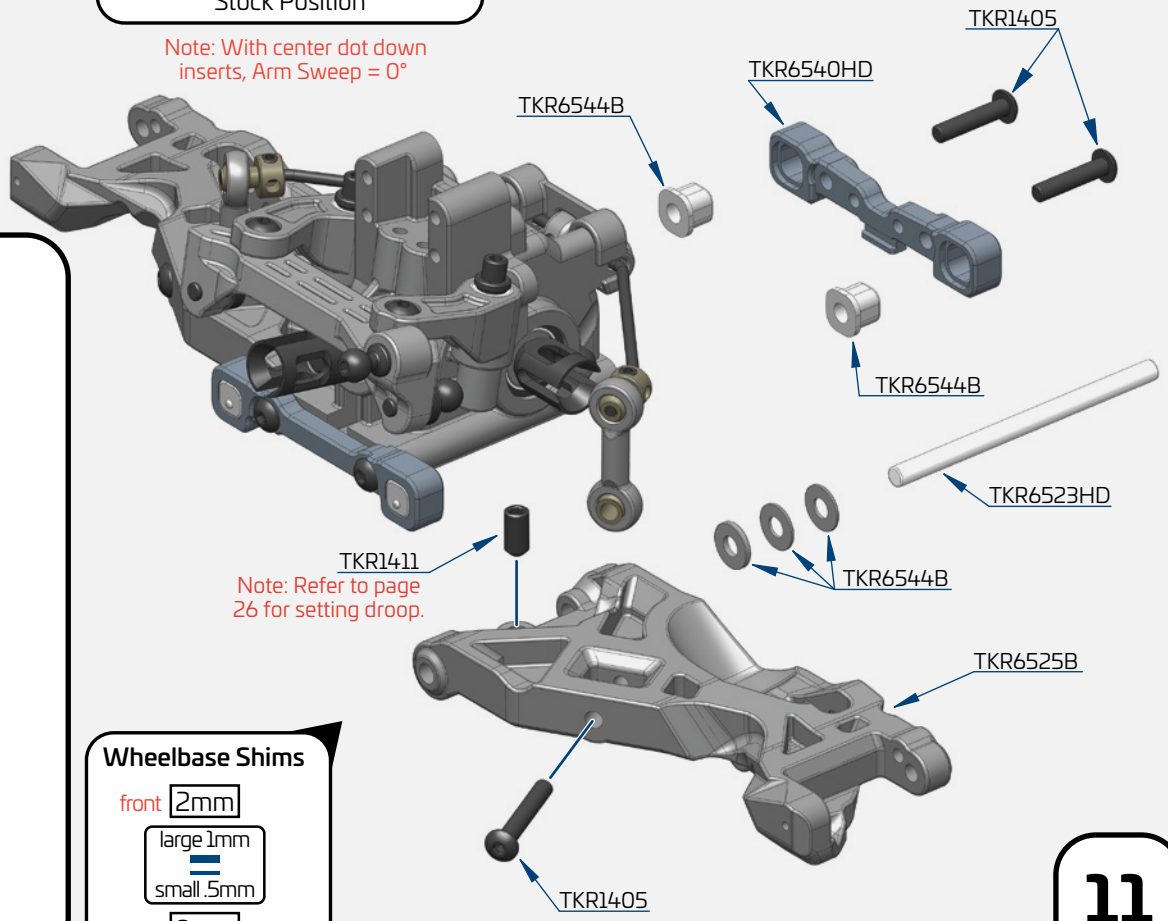

Step G-3

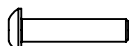
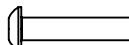
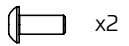
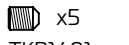

-  x4
TKR1405
M3x14mm Button Head Screw
-  x2
TKR1409
M3x20mm Button Head Screw
-  x2
TKR1463
M2.5x6mm Button Head Screw
-  x5
TKR1601
M3x4mm Set Screw
-  x2
TKR1611
M4x8mm Set Screw

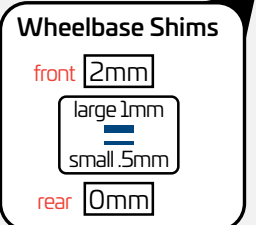

Bag H

Front Spindle/CVA Assembly

Step H-1

Note: These optional steering stop screws and washers are included in case you are experiencing erratic steering control. They provide a mechanical limit to the steering throw and make the car easier to drive by greatly improving the consistency of the steering. They are recommended in addition to limiting steering on your radio to match. Kit setting just the screw with zero washers.

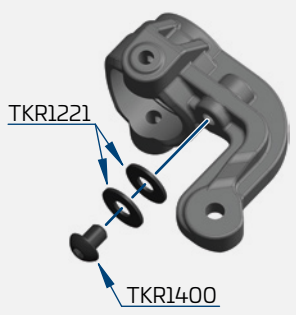

Step H-2

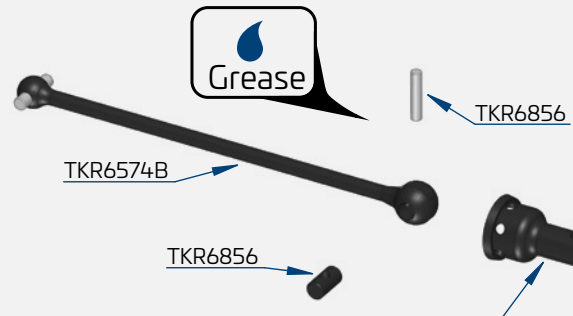

- TKR5571M
- *TKR5571A
- *TKR5571
- *TKR1654X (+1mm)
- *TKR1654 (+1mm)
- *TKR1655 (+2mm) (Option)



* TKR1609
Note: These screws only need to be snug. Do not over-tighten.

Step H-3

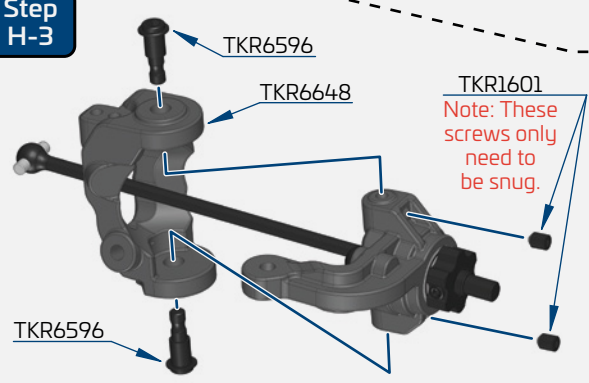

TKR1601
Note: These screws only need to be snug.

Note: Pre-thread the kingpin screws into the spindles prior to installing them into the spindle carriers. This will ensure there will be no binding.



Step H-4

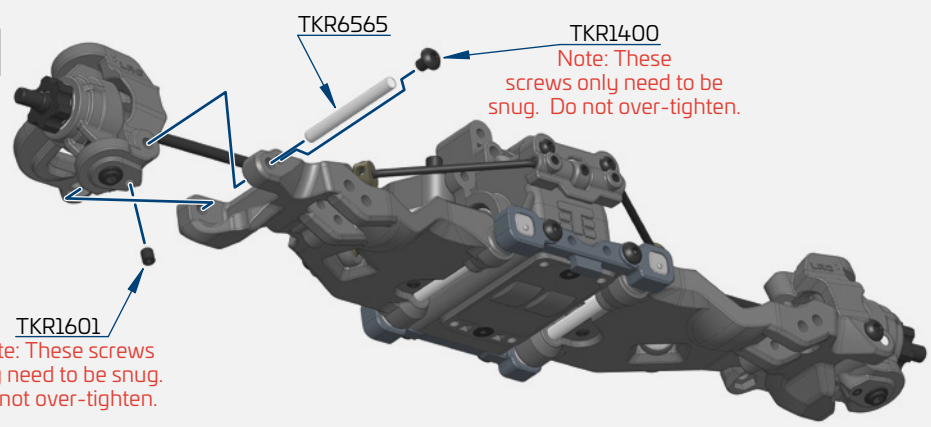

TKR1400
Note: These screws only need to be snug. Do not over-tighten.

TKR1601
Note: These screws only need to be snug. Do not over-tighten.

Step H-5

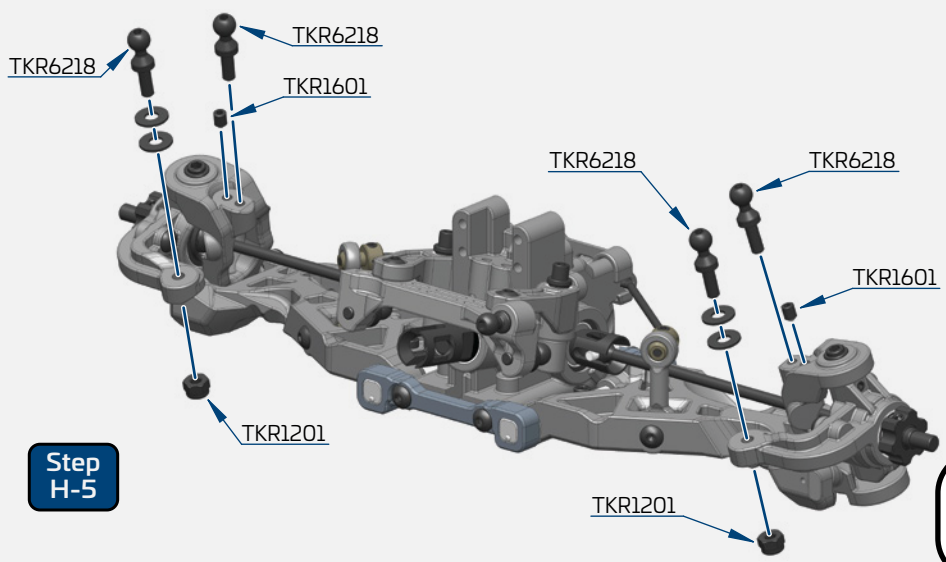

x2
TKR1201
M3 Lock Nut Black

x8
TKR1221
M3x8mm Washer

x2
TKR1229
6x10x0.2mm Shim

x4
TKR1400
M3x4mm Button Head Screw

x8
TKR1601
M3x4mm Set Screw

x2
TKR1609
M3x3mm Set Screw

x2
TKRBB06124
Ball Bearing (6x12x4)

x2
TKRBB10154
Ball Bearing (10x15x4)

x4
TKR6218
M3x8mm Long Neck Ball Stud

Bag I

Steering Links

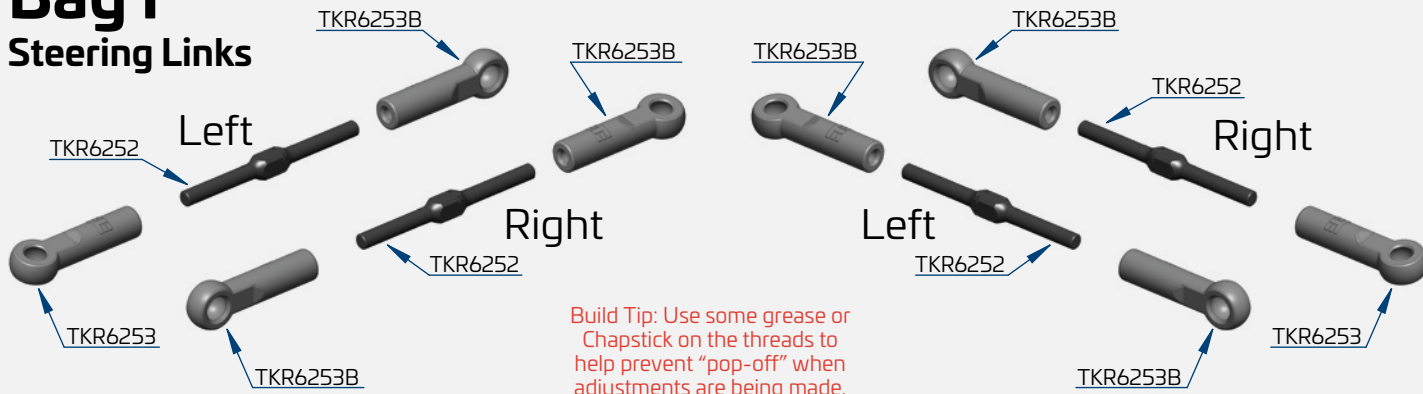

Build Tip: Use some grease or Chapstick on the threads to help prevent "pop-off" when adjustments are being made.

Build Note: Hold the turnbuckle stationary with pliers and push the rod end hard onto the turnbuckle while turning at the same time. Keep in mind that one end of the turnbuckle has normal threads and the other has reverse threads. Start the rod end straight and it will thread on straight.

Step I-1

Steering Links

Note: Notch always goes on left side of vehicle.

Actual Size



Front Camber Links

Note: Notch always goes on left side of vehicle.

Actual Size

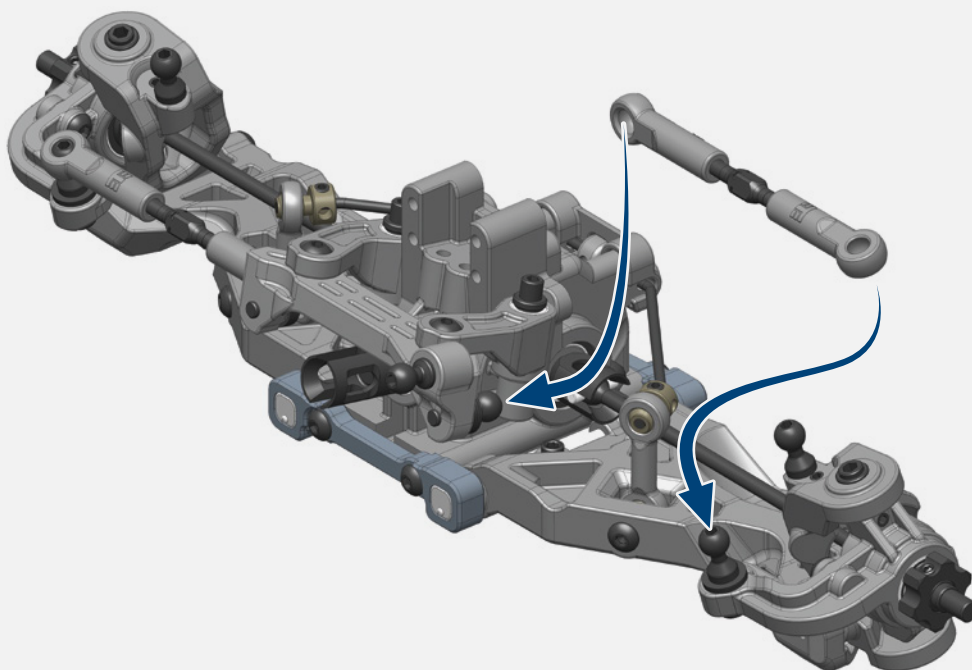

Note: Always press on with T logo visible.



Step I-2

Step I-3

x2
TKR1211
M3 Lock Nut Flange Black

x4
TKR6208
M3x8mm Ball Stud

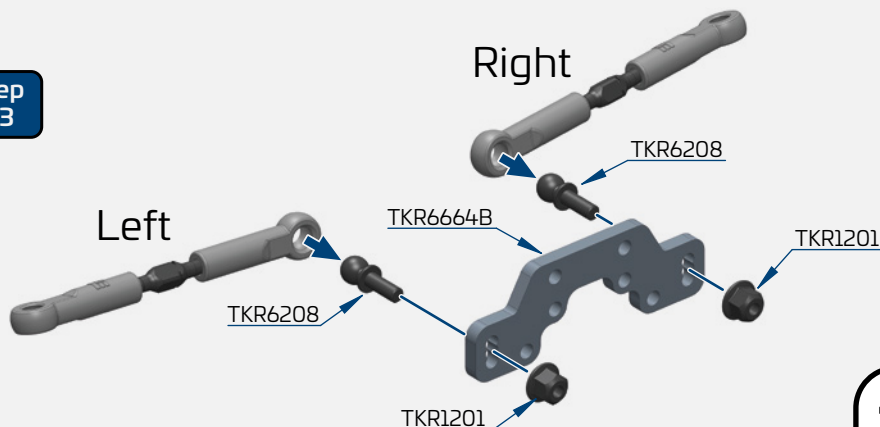

Bag I

Front Camber Plate/Tower

Step
I-4

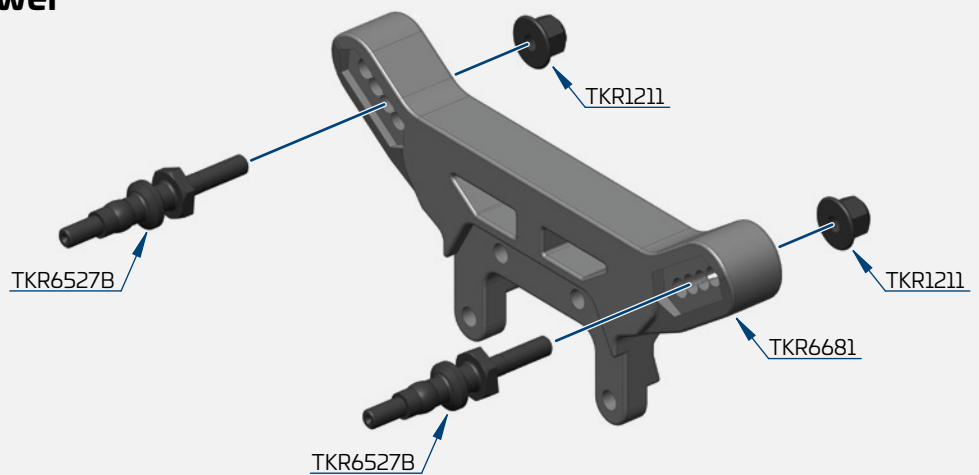

Step
I-5

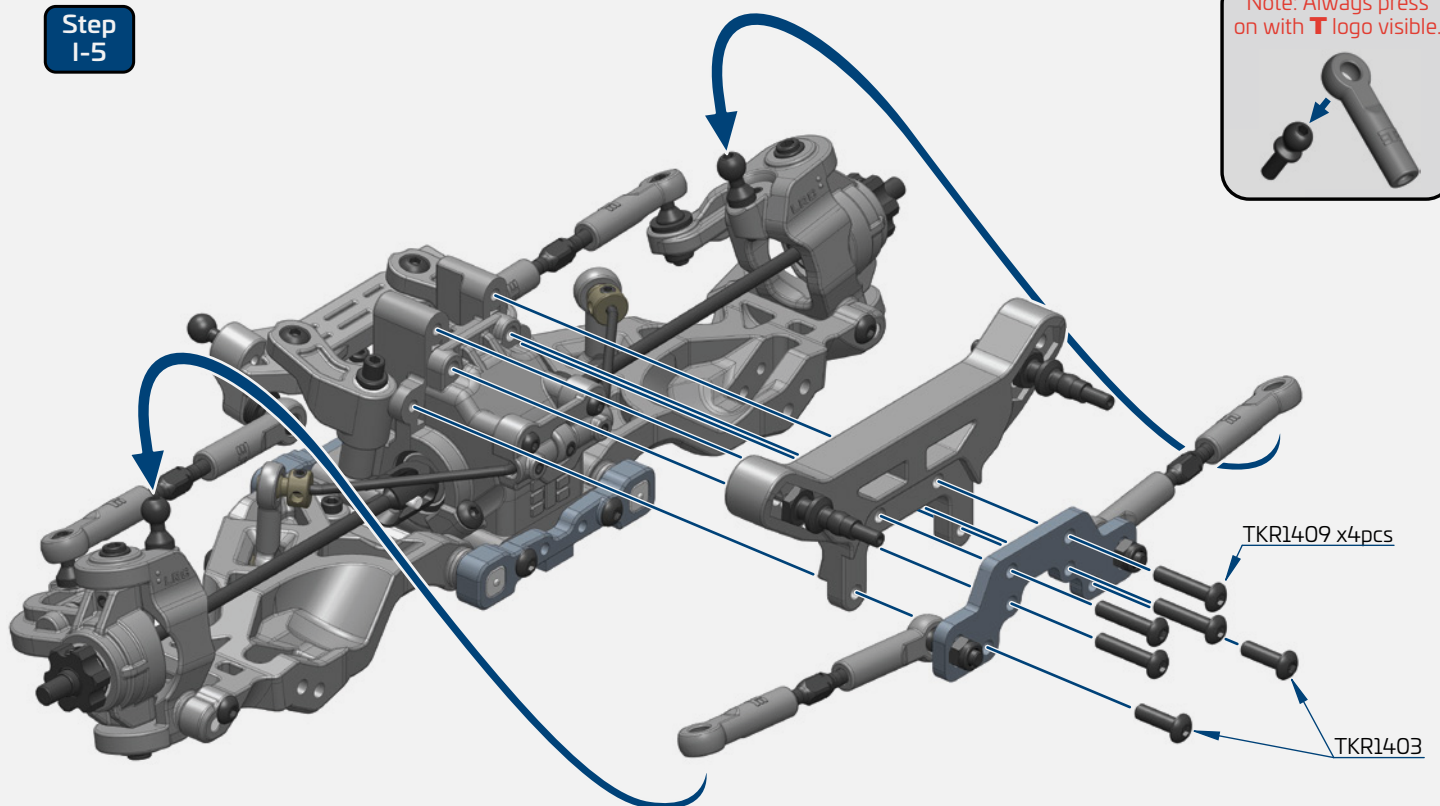

 x2
TKR1201
M3 Lock Nut Black

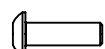
 x2
TKR1403
M3x10mm Button Head Screw

 x4
TKR1405
M3x14mm Button Head Screw

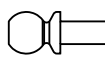
 x2
TKR6208
M3x8mm Ball Stud

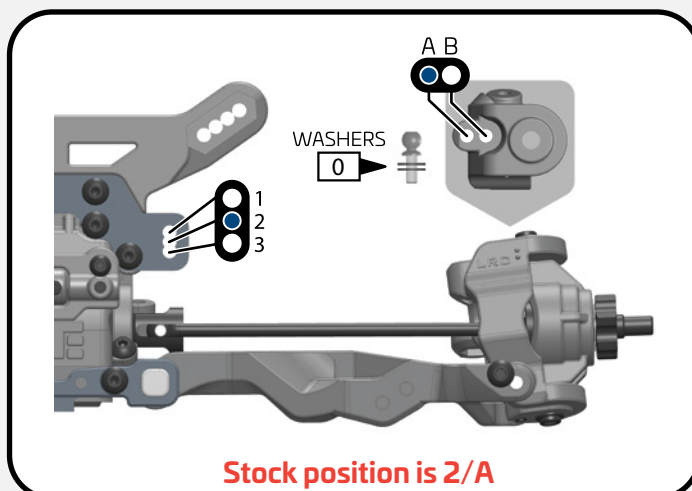

Stock position is 2/A

Bag J

Front/Center Assembly

Step J-1

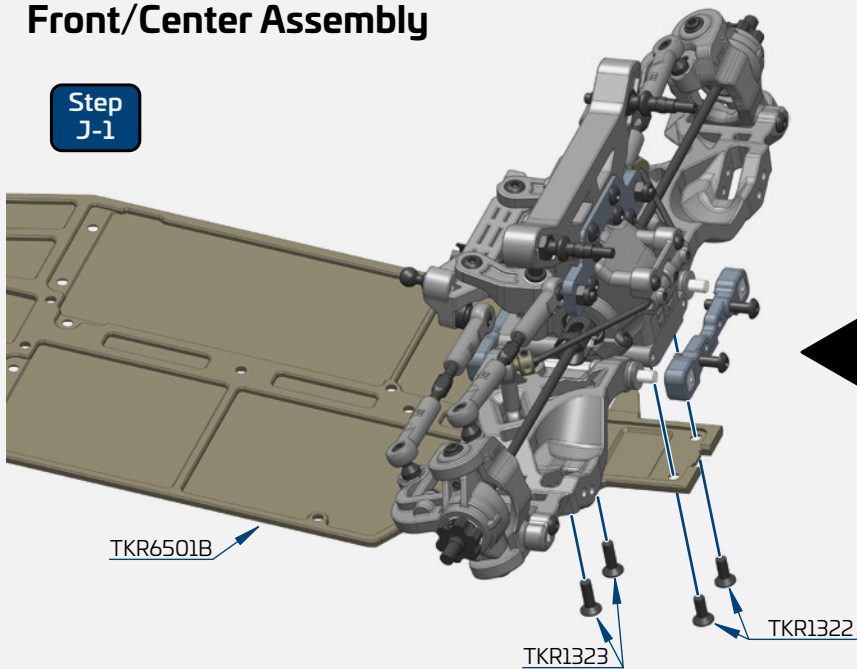

Note: It is necessary to slightly loosen both screws holding the A block in place before attaching the front clip to the chassis. This is due to the fact that the A block is now keyed into the front of the chassis. This feature helps secure the front clip and improves durability.

Step J-2

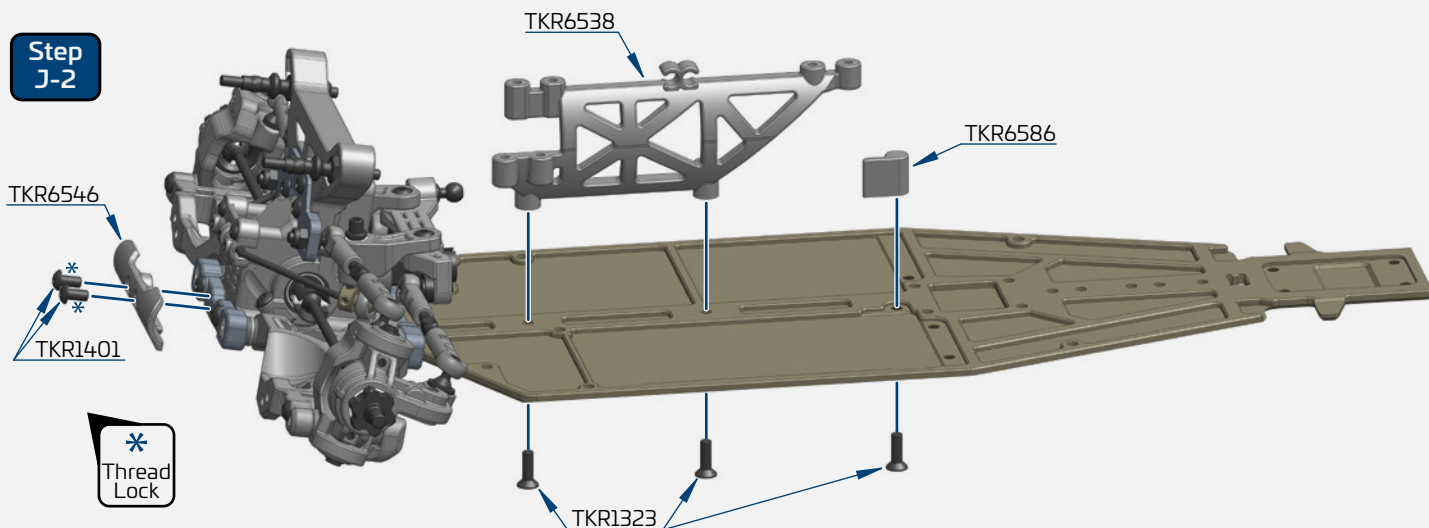

Step J-3

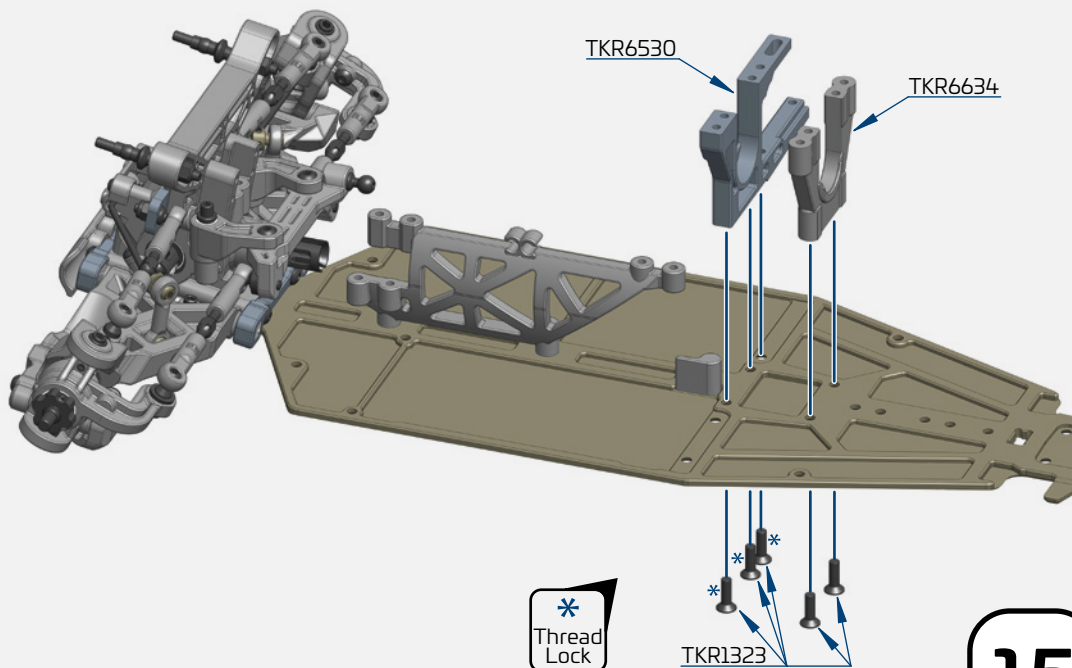

x2
TKR1322
M3x8mm Flat Head Screw

x10
TKR1323
M3x10mm Flat Head Screw

x2
TKR1401
M3x6mm Button Head Screw

*
Thread Lock

Bag J

Center/Rear Assembly

Step J-4

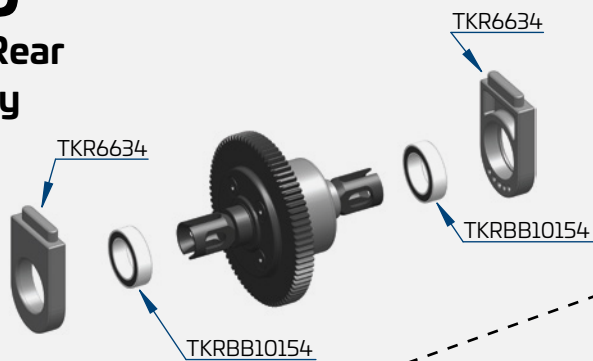

Step J-5

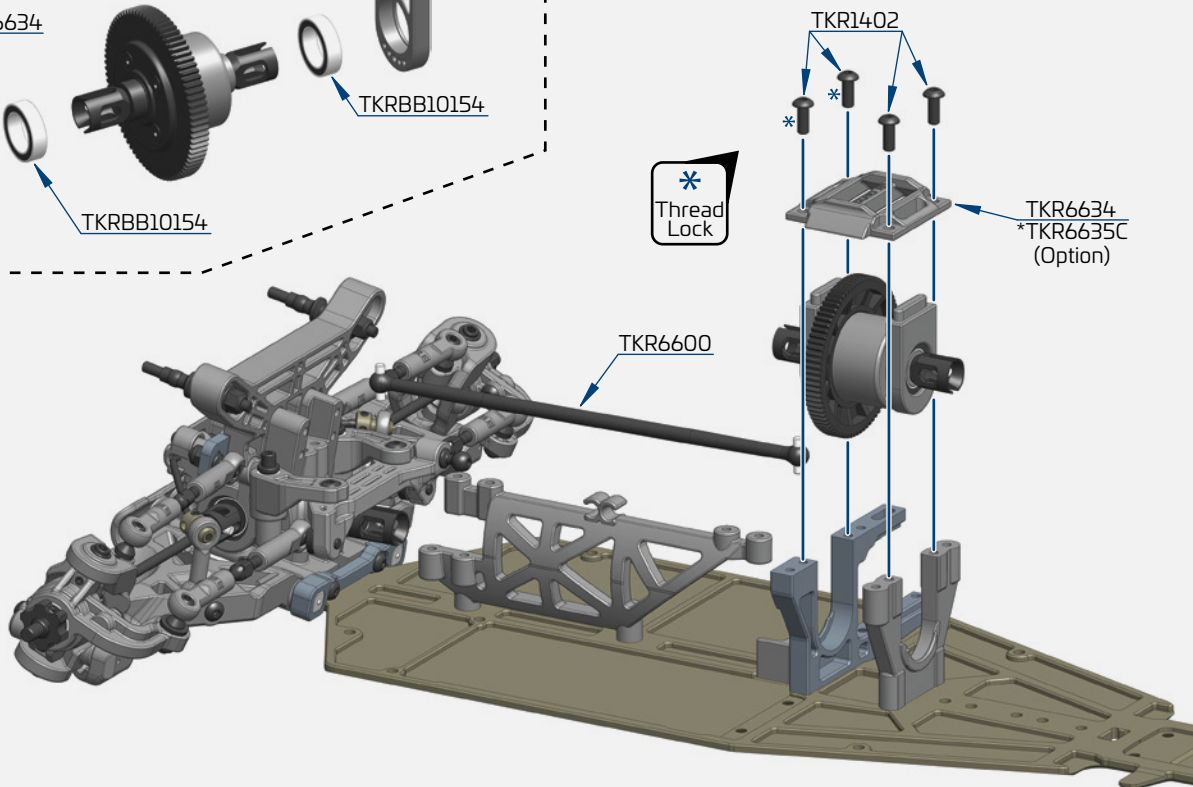

Step J-6

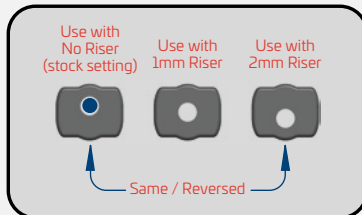

Note: Use both rear braces for the least chassis flex. Use just the long rear for less flex and short rear for the most flex. More flex is best suited for bumpy tracks.

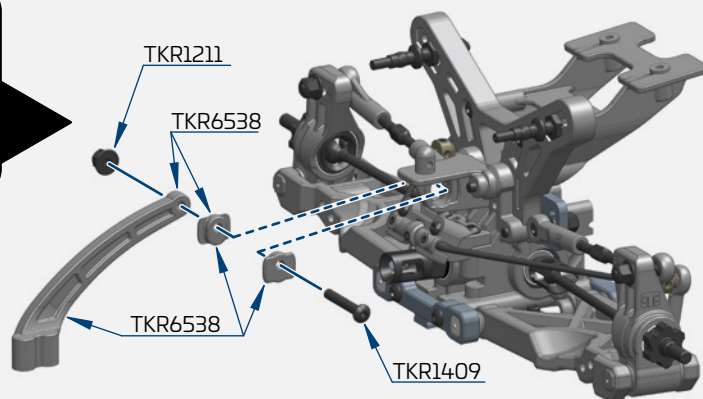

x1
TKR1211
M3 Lock Nut Flange Black

x6
TKR1323
M3x10mm Flat Head Screw

x4
TKR1402
M3x8mm Button Head Screw

x1
TKR1409
M3x20mm Button Head Screw

x2
TKRBB10154
Ball Bearing (10x15x4)

Step J-7

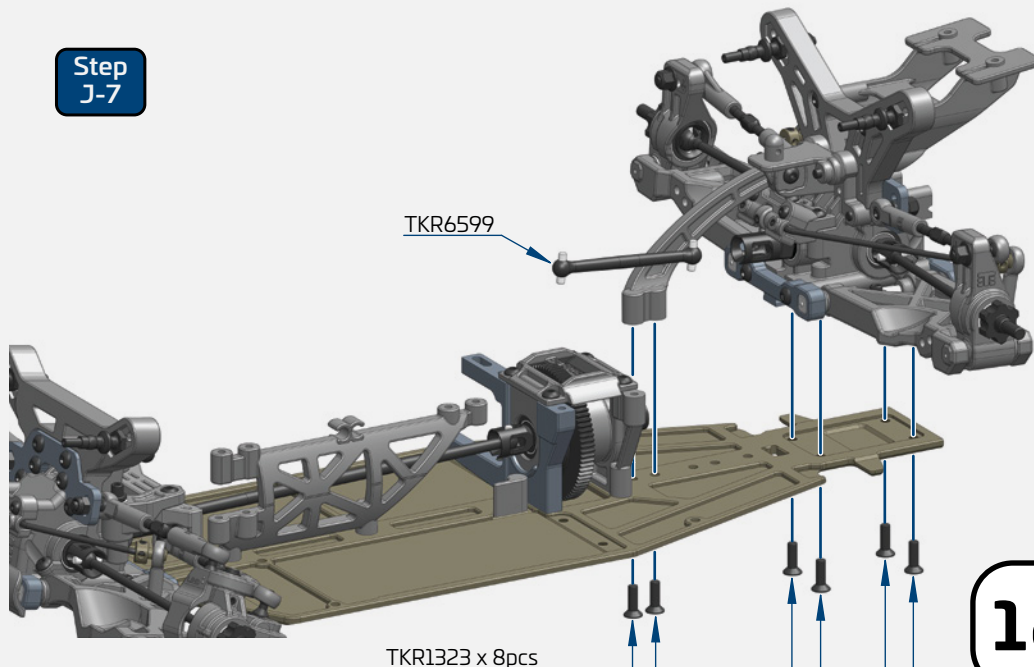

Bag K Front Shock Assembly

Step K-1

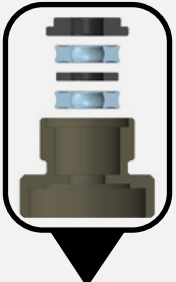

Step K-2

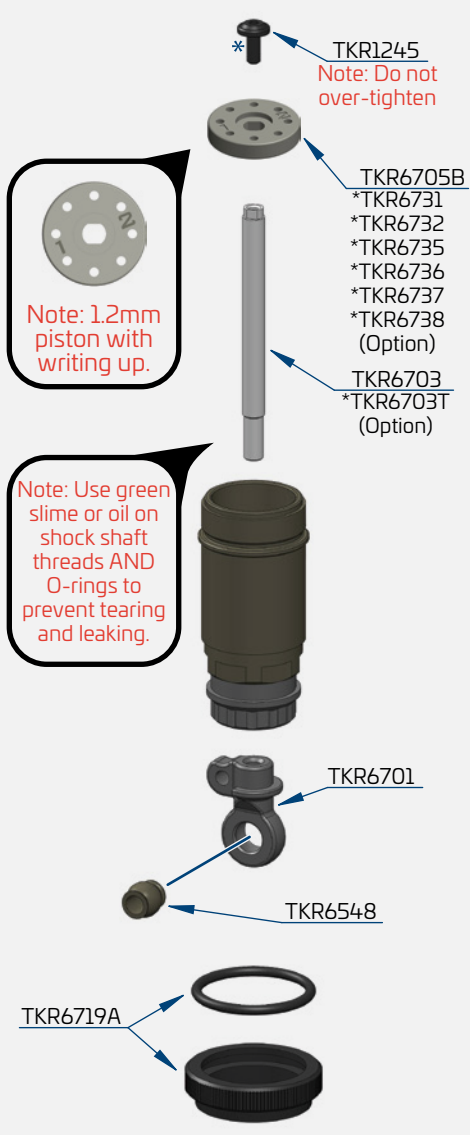

Note: 1.2mm piston with writing up.

Note: Use green slime or oil on shock shaft threads AND O-rings to prevent tearing and leaking.

Step K-3



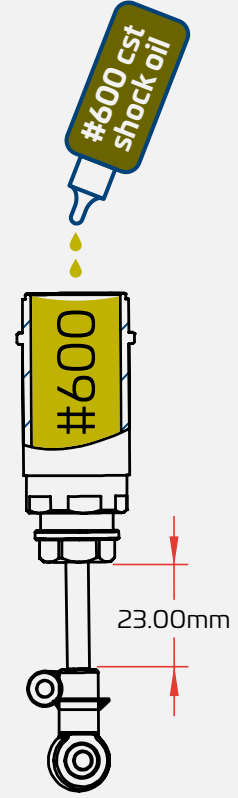

Refer to filling instructions on page 19 during this step.

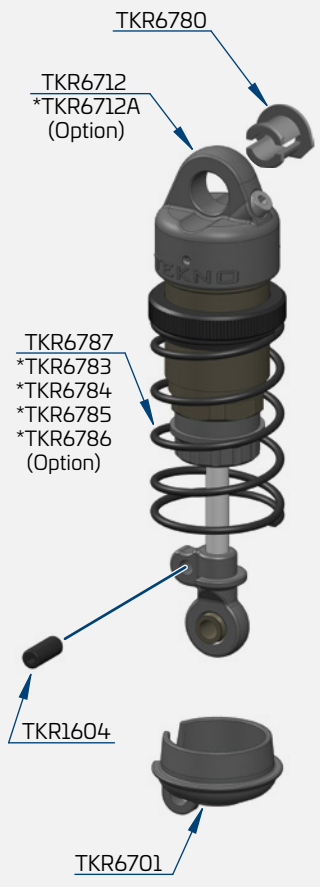

Note: Screw rod end on until distance measures 23mm at full extension.

Step K-4



-  x2
TKR1211
M3 Lock Nut Flange Black
-  x2
TKR1240
M3x18mm Shock Mnt Screw
-  x2
TKR1245
M2x5mm Piston Screw
-  x2
TKR1248
M2x4mm Emulsion Screw
-  x2
TKR1604
M3x8mm Set Screw

Step K-5

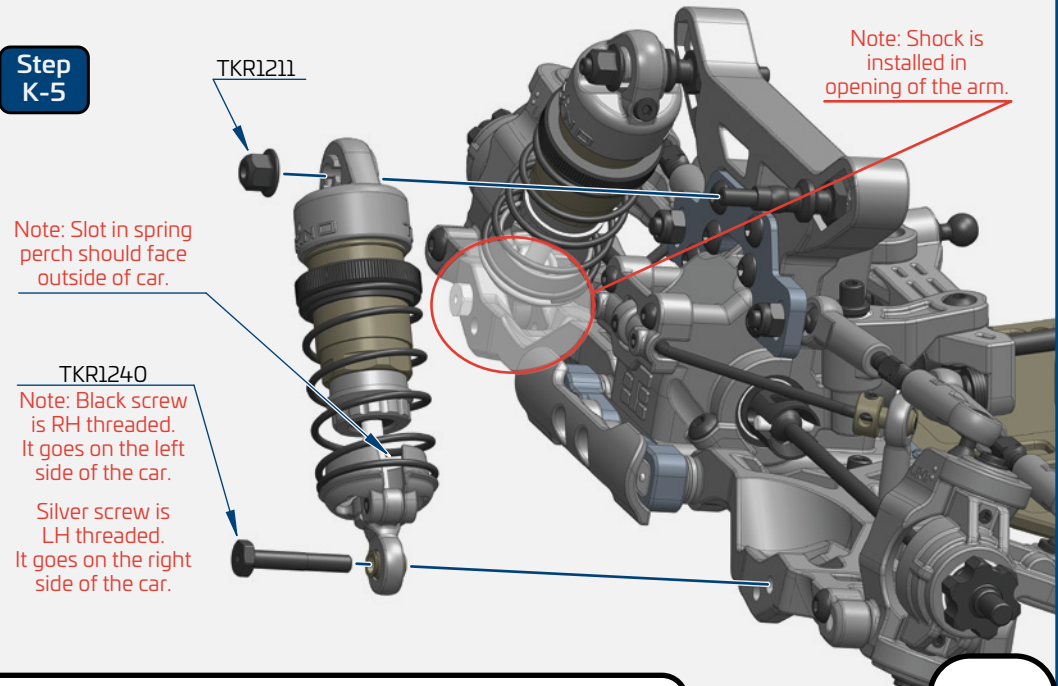

Note: Slot in spring perch should face outside of car.

TKR1240
Note: Black screw is RH threaded. It goes on the left side of the car.

Silver screw is LH threaded. It goes on the right side of the car.

Note: Shock is installed in opening of the arm.

- Stock shock position is 2nd hole from inside on the tower and outside hole on the arm (2/B)
- Shock length (droop) is 78mm
- Stock front ride height is 19mm

Bag L Rear Shock Assembly

Step L-1

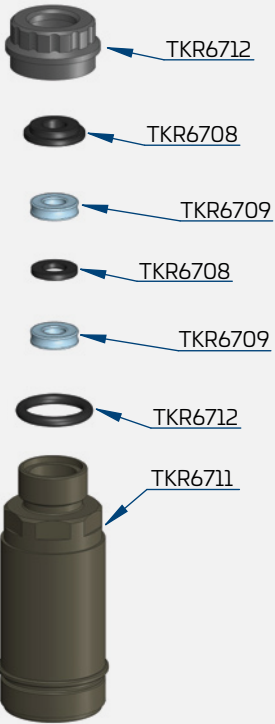
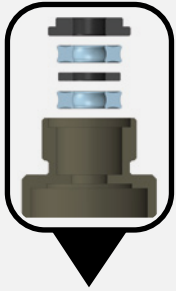

Step L-2

* Thread Lock

TKR1245
Note: Do not over-tighten

Note: 1.3mm piston with writing up.

Note: Use green slime or oil on shock shaft threads AND O-rings to prevent tearing and leaking.

TKR6719A



Step L-3

Refer to filling instructions on page 19 during this step.

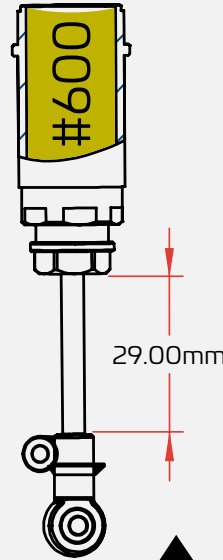

Note: Screw rod end on until distance measures 29mm at full extension.

Step L-4

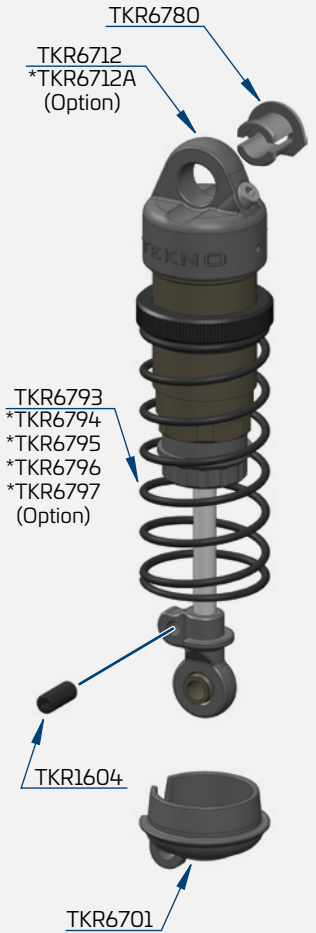

x2
TKR1211
M3 Lock Nut Flange Black

x2
TKR1240
M3x18mm Shock Mnt Screw

x2
TKR1245
M2x5mm Piston Screw

x2
TKR1248
M2x4mm Emulsion Screw

x2
TKR1604
M3x8mm Set Screw

Step L-5

Note: Slot in spring perch should face outside of car.

TKR1240
Note: Black screw is RH threaded. It goes on the left side of the car.
Silver screw is LH threaded. It goes on the right side of the car.

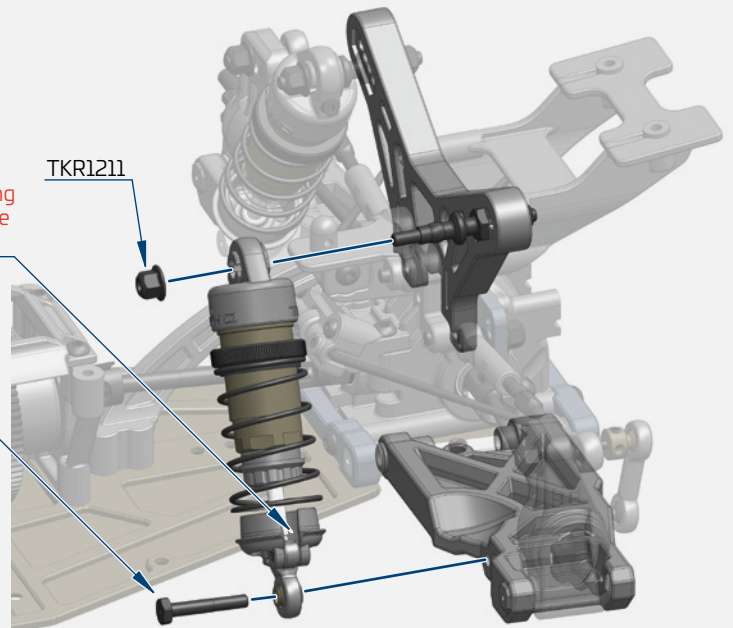

● Stock shock position is 2nd hole from inside on the tower and inside hole on the arm (2/A)

● Shock length (droop) is 89mm
● Stock rear ride height is 20mm

Shock Filling Instructions

For both front and rear shocks

We've found it's easiest to complete steps 1 & 2 on each shock before moving on to step 3. By the time you've finished step 2 on the last shock, the first one will be ready for step 3.

Step 1. Start by drilling out the emulsion hole if necessary. Use a 1/16th (or 1.6mm) drill bit to drill all the way through and clear any flashing created by this. Insert the four larger o-rings into the emulsion caps and set aside. Install the small o-rings onto the small emulsion screws.

Step 2. Fill shock with oil all the way to the top and pump the shock shaft up and down 3-5 times.

Step 3. Screw on the cap all the way tight (shock tool TKR1115 is helpful for holding the shock body). Be careful to not cross-thread the caps. Start by turning in the opposite direction before tightening.

Step 4. With the shock at about a 45° angle, push and hold the shock shaft to the top of the stroke and insert the prepared emulsion screw/seal. Oil should leak out during this process. If it does not, add more oil. Tighten the screw until snug (do not over-tighten). Wipe off excess oil before moving on to step 5.

Step 5. Pump the shock shaft up and down about 20 times vigorously. This emulsifies the oil.

Step 6. With the shock shaft fully extended, remove the emulsion screw from the cap to do the final bleed.

Step 7. With the shock at about a 45° angle, push and hold the shock shaft to the top and insert the prepared emulsion screw/seal again. Oil will leak out during this process. Finish by tightening the screw until snug (do not over-tighten).

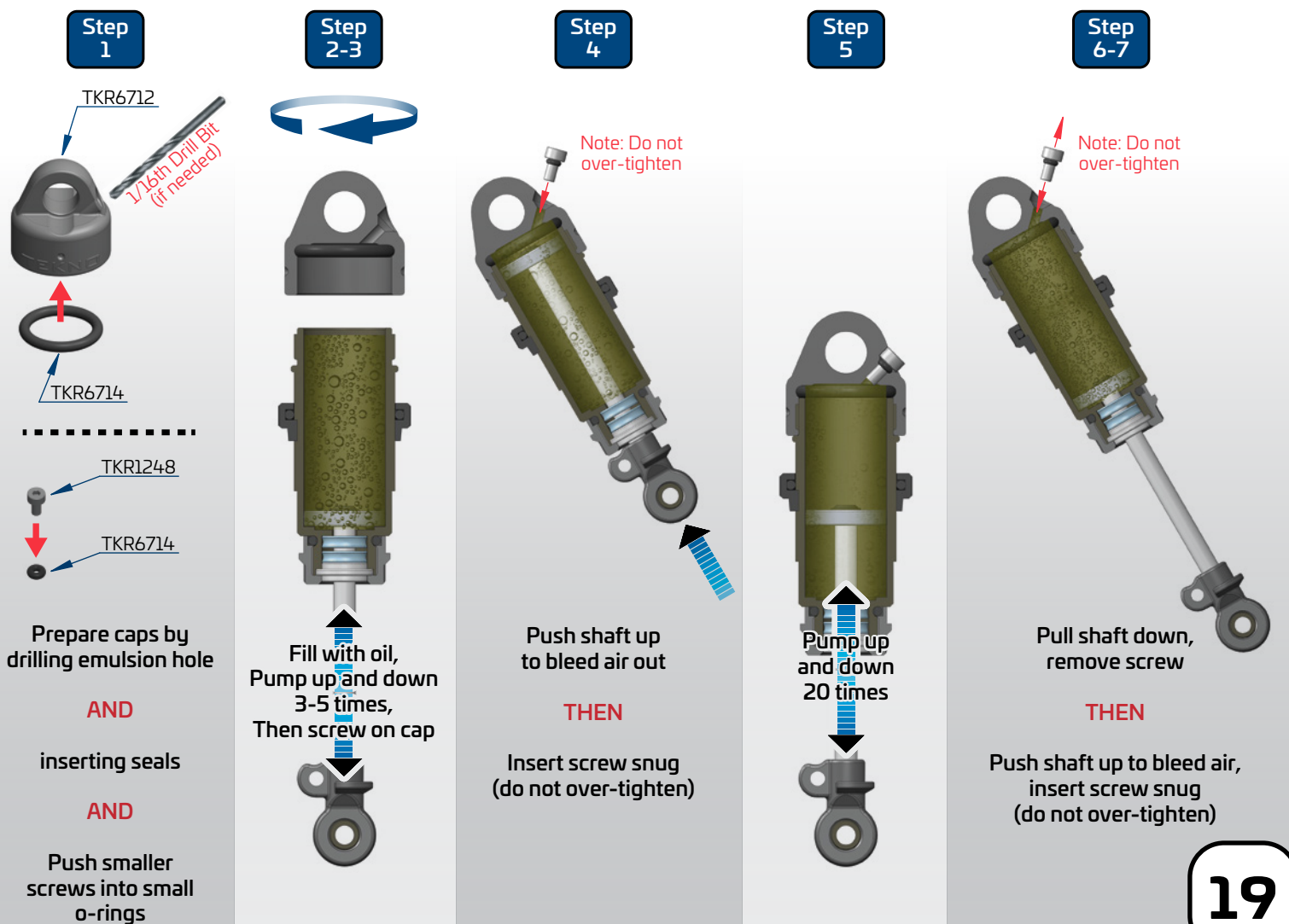

Bag M

Final Assembly

Step M-1

IMPORTANT RADIO SETUP TIPS, MUST READ:

The Tekno RC EB4.10.2 is highly tunable, but can be very aggressive depending on track conditions and tires used. To help with this, we recommend that you are well informed about setting up your Steering EPA, Servo Speed, Dual Rate, and Exponential Curves.

PLEASE READ PAGE 28 FOR MORE DETAILS.

Steering servo (not included)
 Note: We recommend using a low profile servo with at least 180 oz/in torque and metal gears. Running less than our recommended rating will increase the chance of premature servo failure.

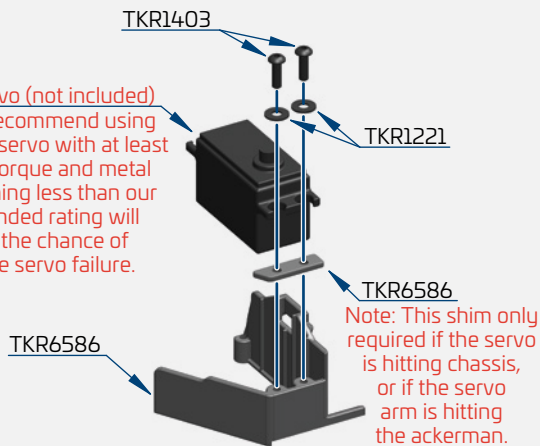

Step M-2

Note: This shim only required if the servo is hitting chassis, or if the servo arm is hitting the ackerman.

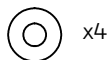
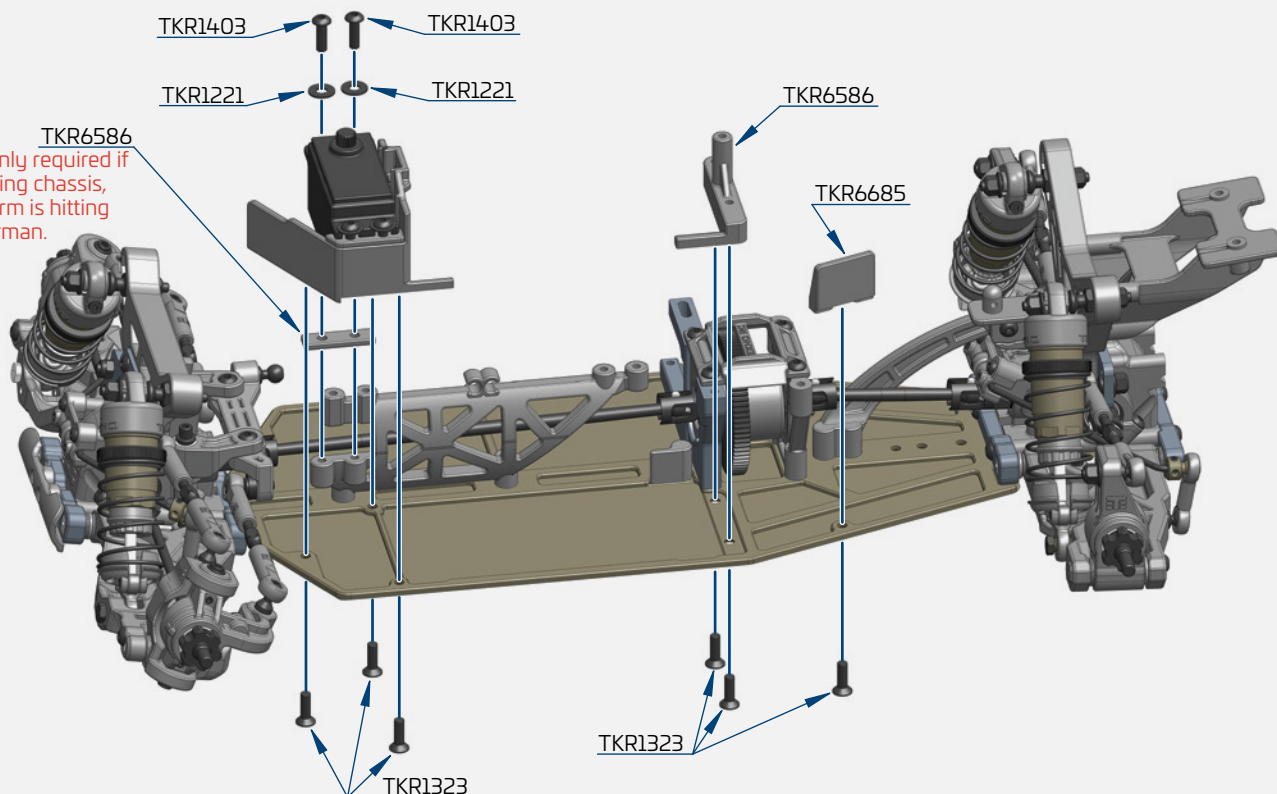

x4
TKR1221
M3x8mm Washer

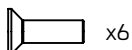

x6
TKR1323
M3x10mm Flat Head Screw

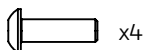

x4
TKR1403
M3x10mm Button Head Screw



x2
TKR1522
M3x8mm Cap Head Screw

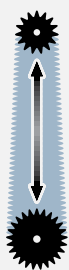

Motor (w/2 cell)	Small Track (48pitch pinion/spur)	Large Track (48pitch pinion/spur)	Small Track (32pitch pinion/spur)	Large Track (32pitch pinion/spur)
	(50-80 ft Straight)	(80-150 ft Straight)	(50-80 ft Straight)	(80-150 ft Straight)
5.5T	18/81 tooth	19/81 tooth	12/53 tooth	12-13/81 tooth
6.5T	19/81 tooth	20/81 tooth	12-13/53 tooth	13/53 tooth
7.5T	20/81 tooth	21/81 tooth	13-14/53 tooth	13-14/53 tooth
8.5T	21/81 tooth	22/81 tooth	14/53 tooth	14-15/53 tooth
10.5T	22/81 tooth	23/81 tooth	14-15/53 tooth	15/53 tooth
13.5T	22/81 tooth	24/81 tooth	14-15/53 tooth	15/53 tooth

Step M-3

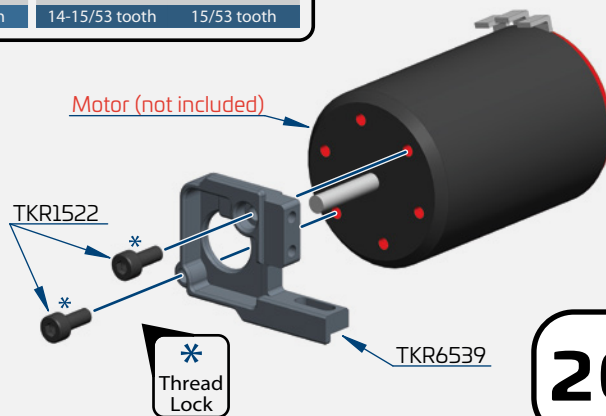

*
Thread
Lock

Bag M

Final Assembly

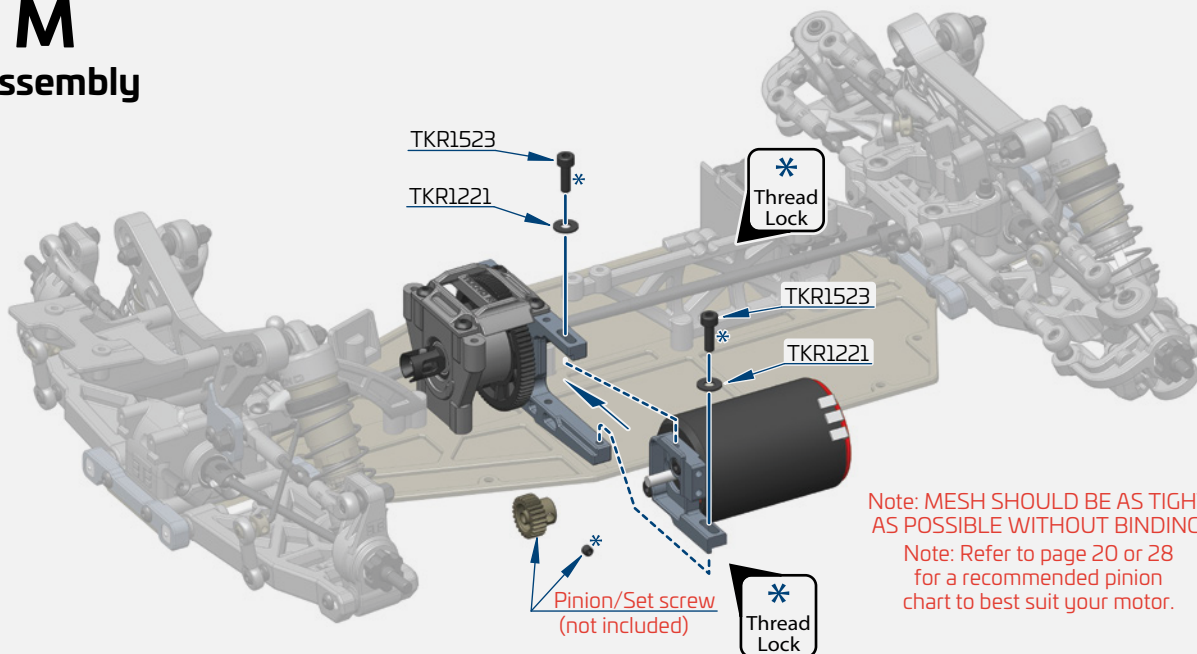

Step
M-4

Step
M-5

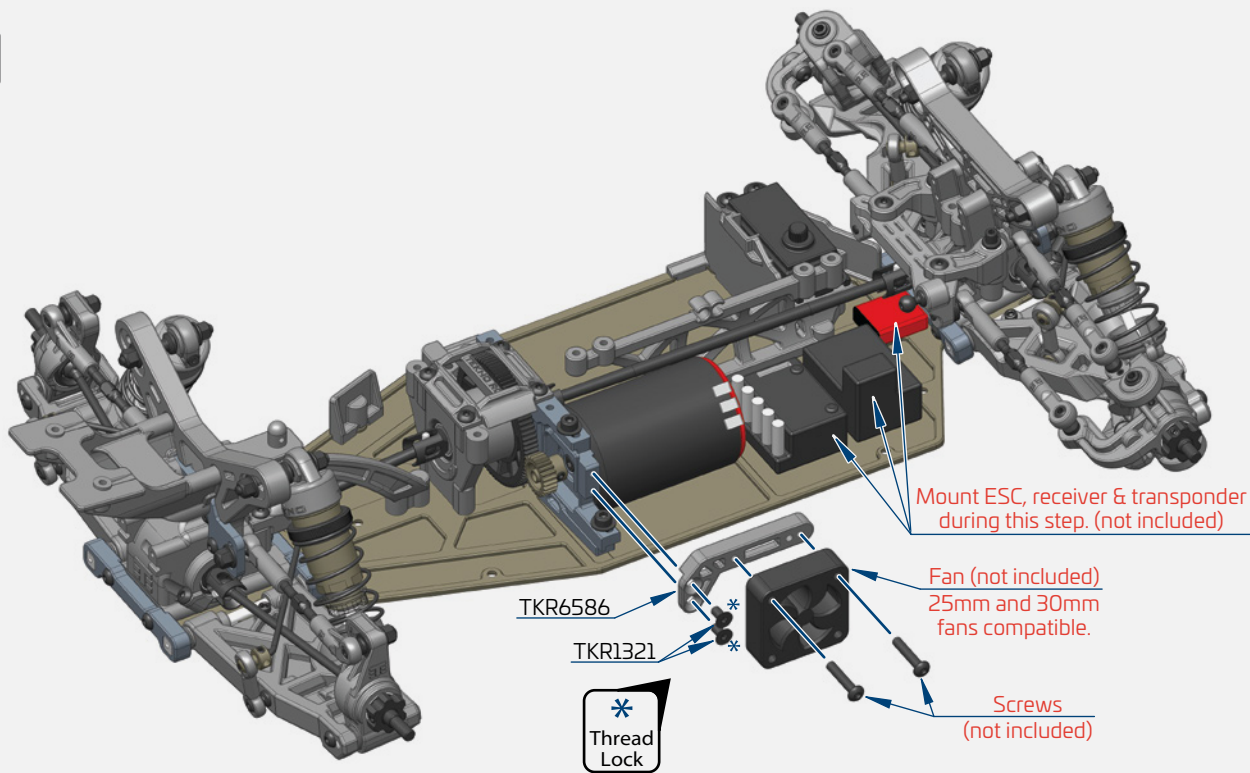

x2

TKR1221
M3x8mm Washer

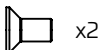

x2

TKR1321
M3x6mm Flat Head Screw

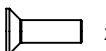

x3

TKR1323
M3x10mm Flat Head Screw

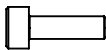

x2

TKR1523
M3x10mm Cap Head Screw

Step
M-6

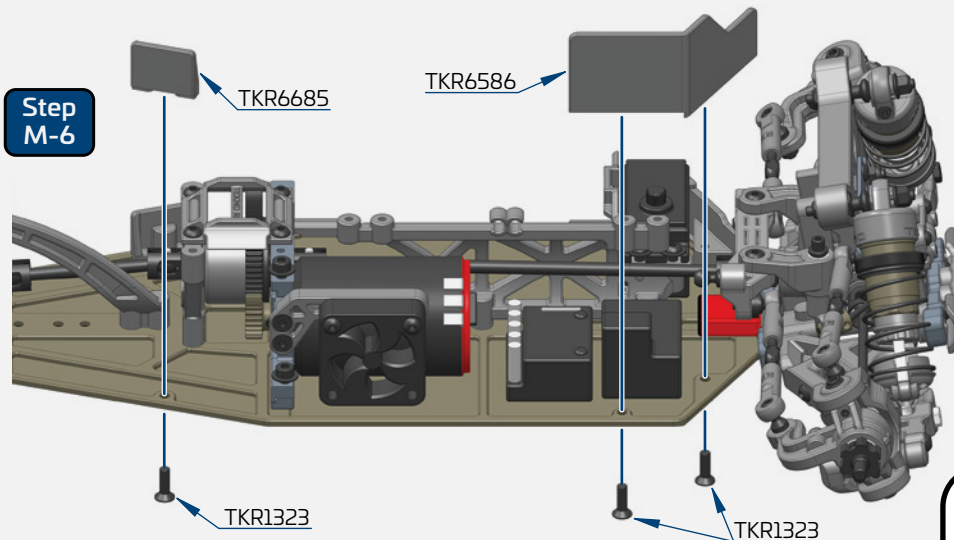

Bag M

Final Assembly



Step
M-7

Step
M-8

Note: Servo horn orientation.

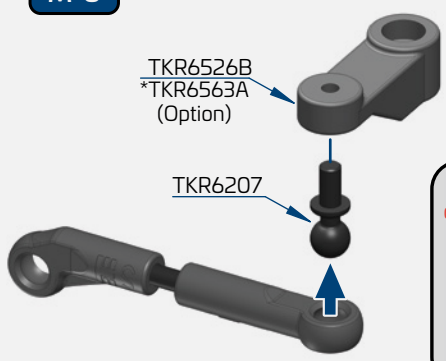

Step
M-9

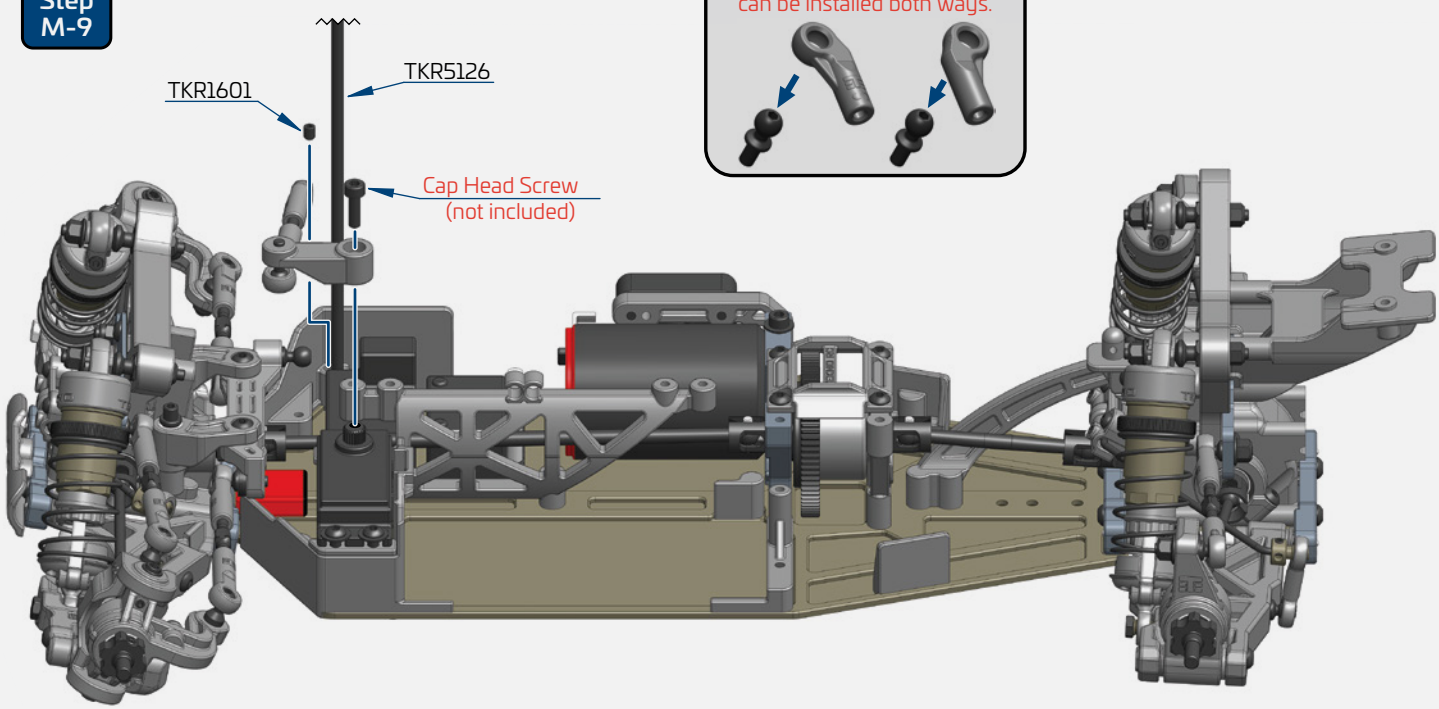
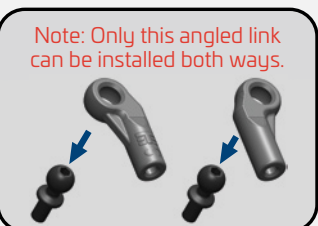

Step
M-10

SERVO HORN ALIGNMENT

Note: Servo horn should be positioned after trim and sub-trim have been zero'd out. It should be positioned about 4 degrees off parallel from the steering bellcranks.

Steering bellcranks should be perfectly parallel from front to rear of the chassis.

- x1
TKR1601
M3x4mm Set Screw
- x1
TKR5238
M3x30 Threaded Rod
- x1
TKR6207
M3x6mm Ball Stud

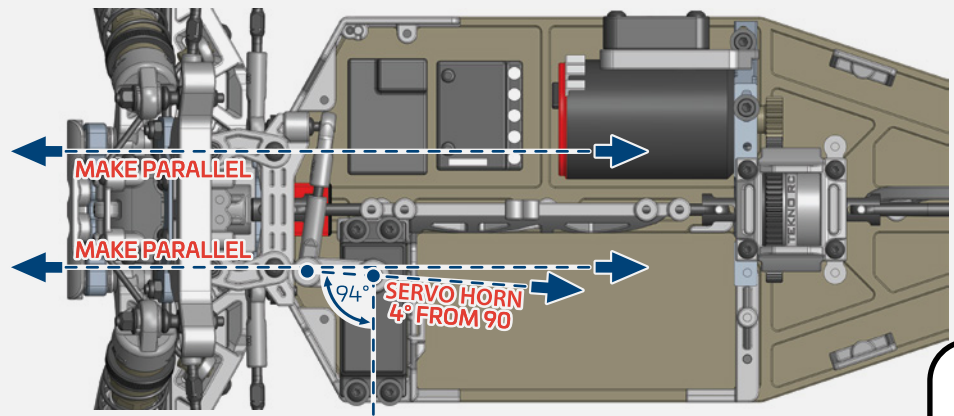

Bag N

Final Assembly



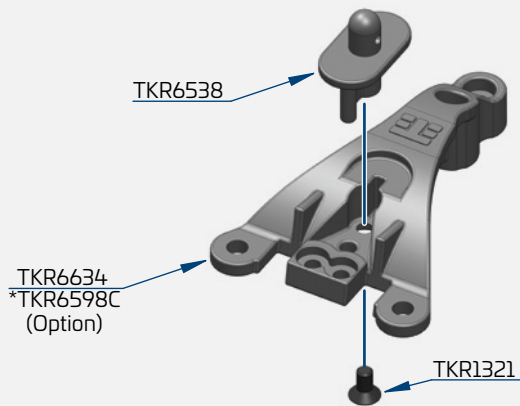

Step N-1

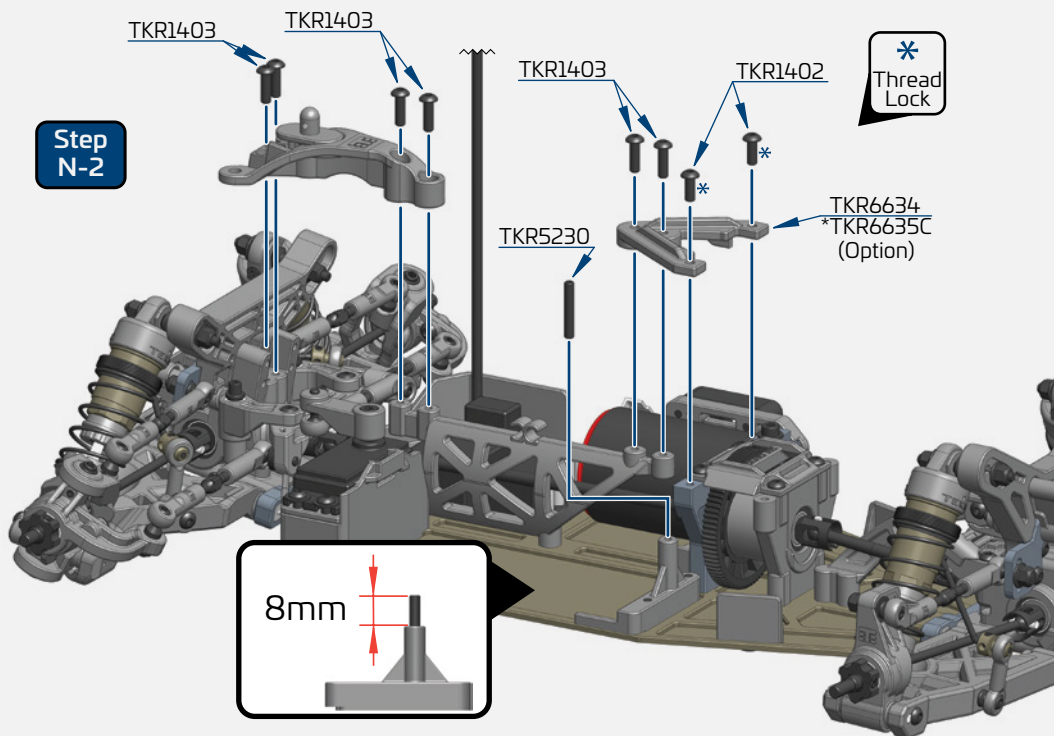

Step N-2



* Thread Lock

-  x1
TKR1321
M3x6mm Flat Head Screw
-  x2
TKR1402
M3x8mm Button Head Screw
-  x6
TKR1403
M3x10mm Button Head Screw
-  x1
TKR5230
M3x18 Threaded Rod

Bag O

Wing

Step O-1

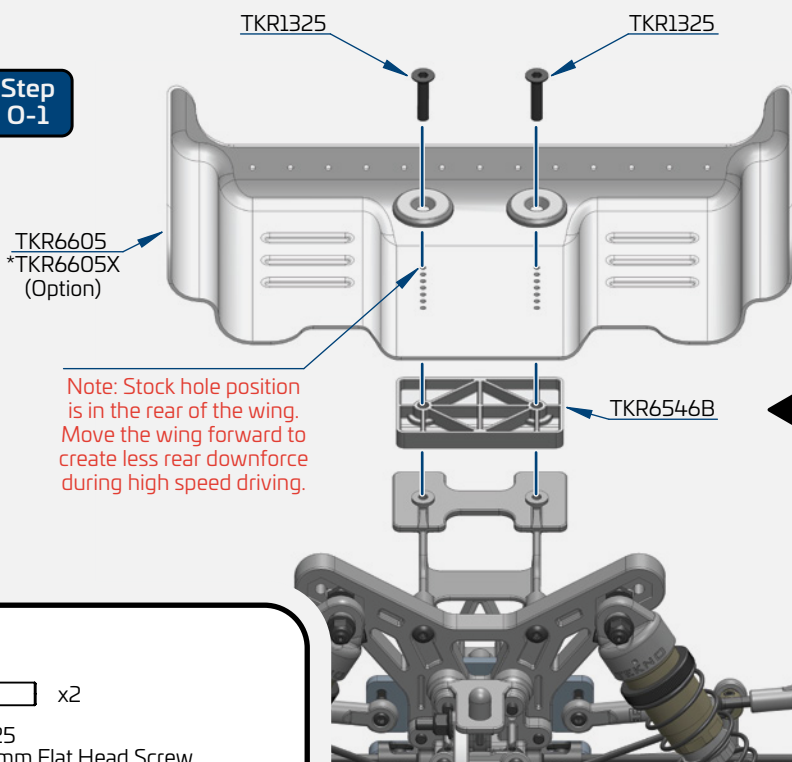

Note: Stock hole position is in the rear of the wing. Move the wing forward to create less rear downforce during high speed driving.

WING OPTIONS

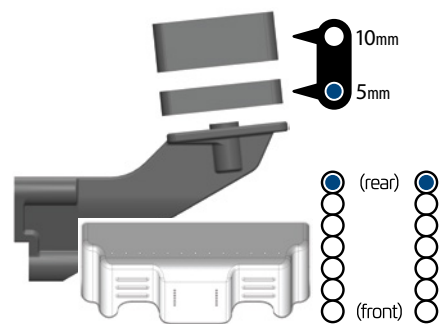

Note: Taller riser will provide more downforce, and give more rear traction everywhere, will jump more nose up, have less steering into a turn, and have slightly less top speed. Shorter riser will provide less downforce, will have less rear traction everywhere, will jump more level or nose down, have more steering into a turn, and have a slightly higher top speed.

Note: The taller riser requires M3x20mm TKR1329 (not included).

-  x2
TKR1325
M3x14mm Flat Head Screw

Bag 0

Body/Tires

Step
0-2

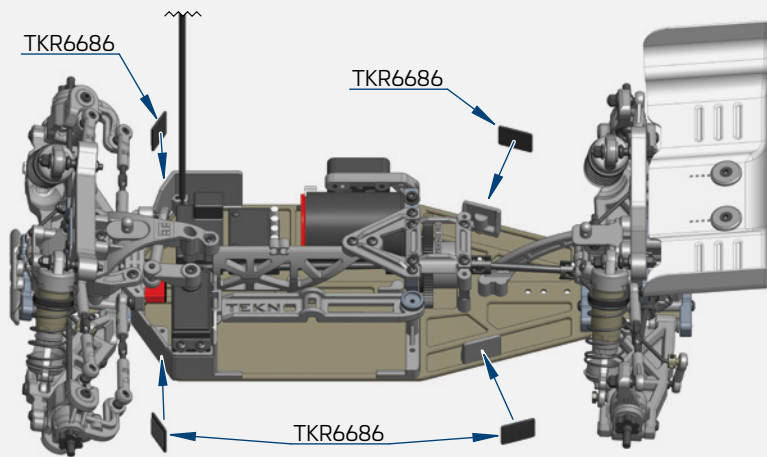

Step
0-3

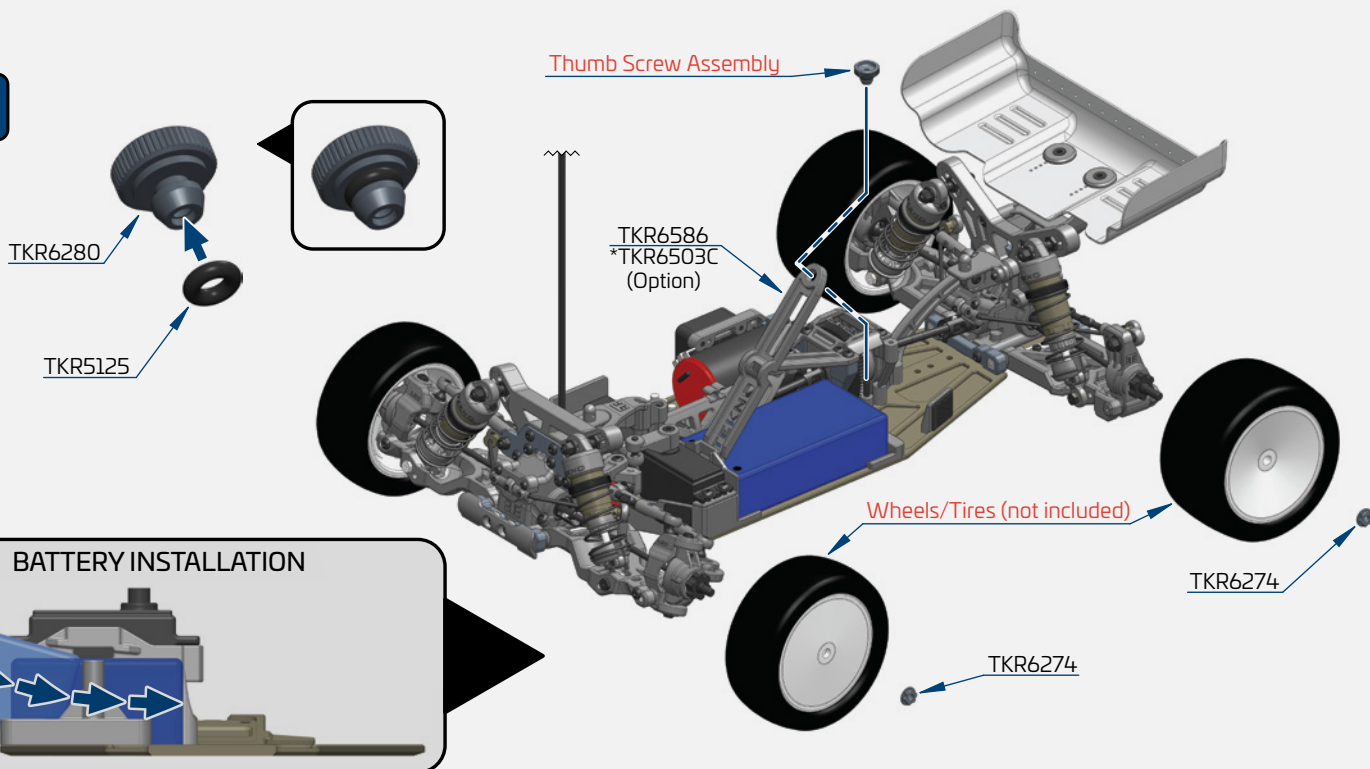

Step
0-4

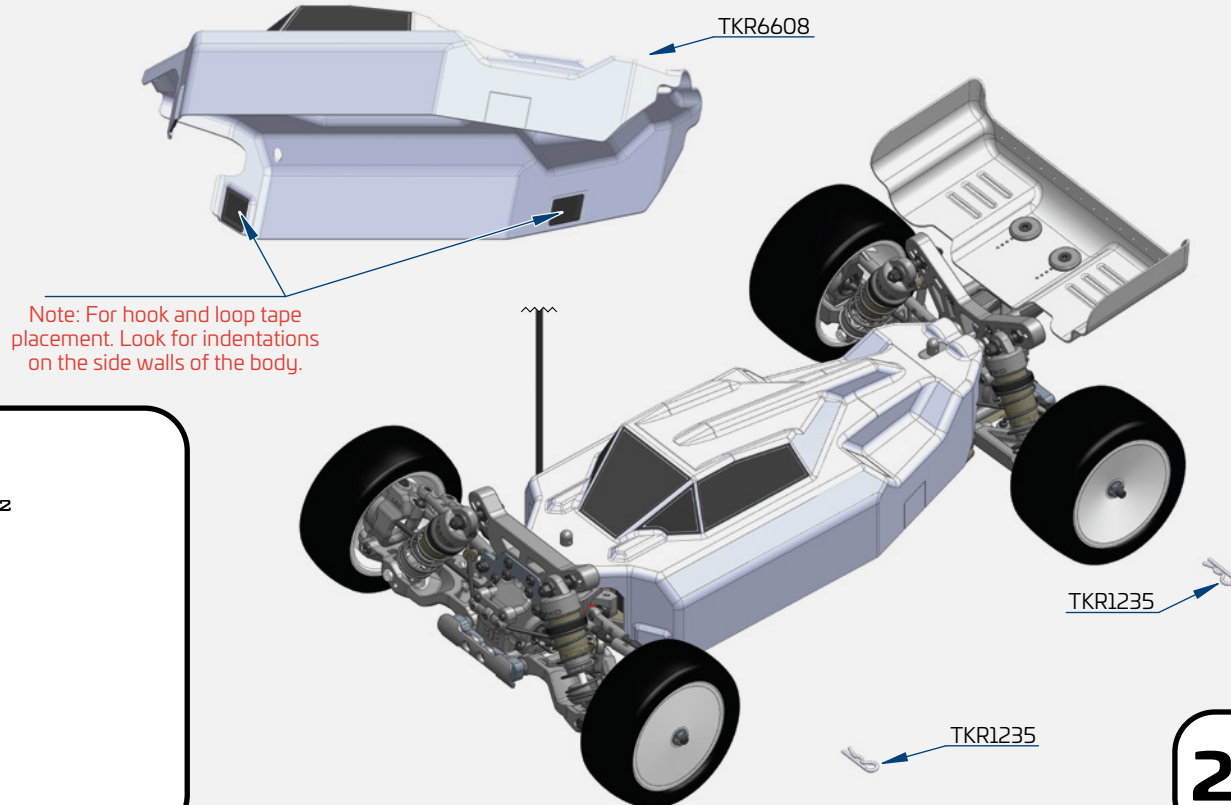

TKR1235
BODY CLIP



TKR6274
WHEEL NUT

Bag P

Optional Tall Servo Mounting

Step P-1

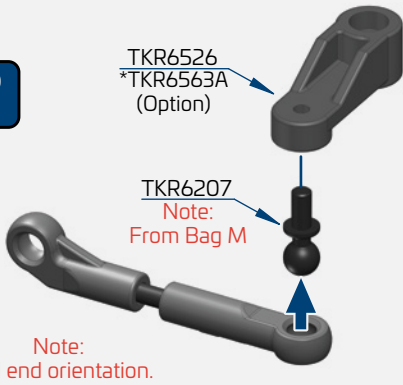

TKR6526
*TKR6563A
(Option)

TKR6207
Note:
From Bag M

Note:
Rod end orientation.

Note:
Servo horn orientation.

Note: Always press on with **T** logo visible.



Step P-2

TKR1403
Note: From Bag M

Steering servo (not included)
Note: We recommend using a servo with at least 180 oz/in torque and metal gears. Running less than our recommended rating will increase the chance of premature servo failure.

TKR6586

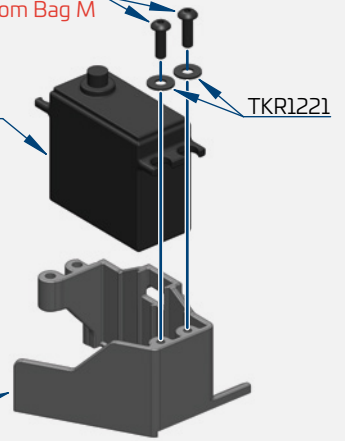

Step P-3

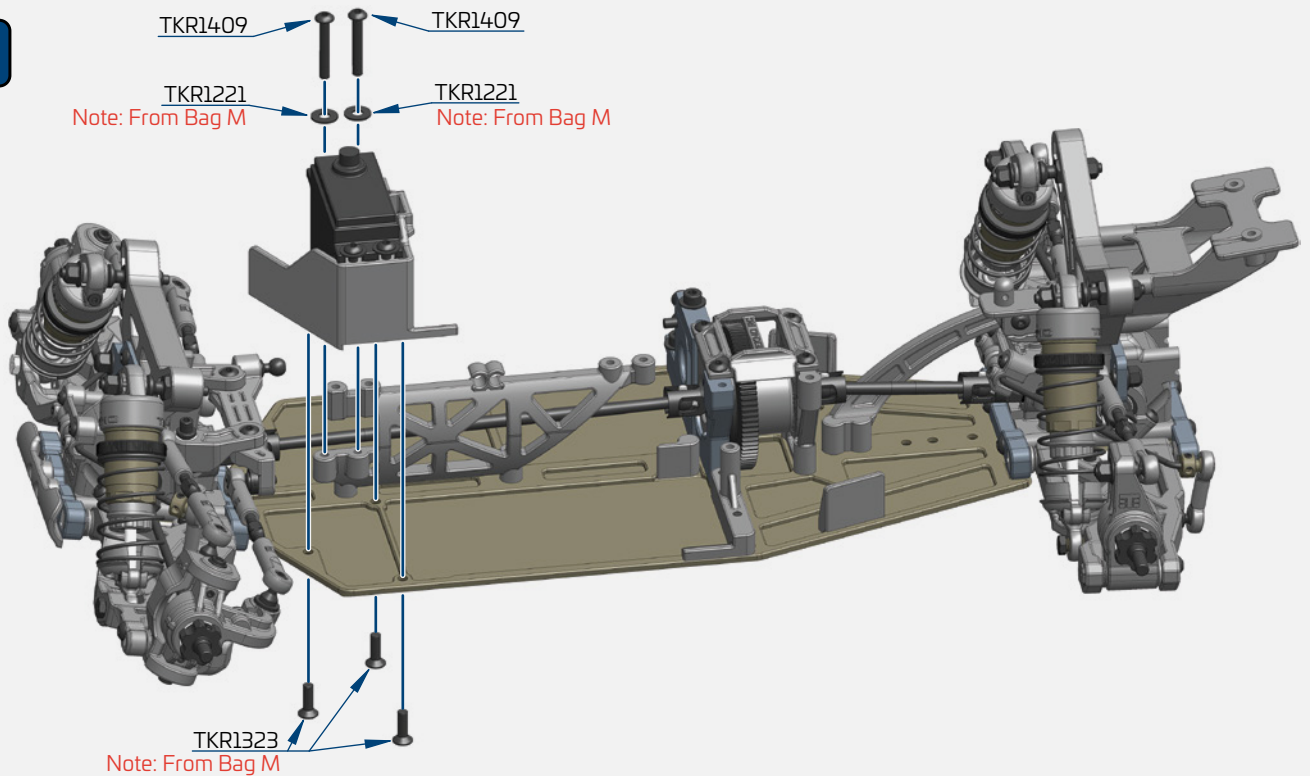

TKR1409

TKR1409

TKR1221

Note: From Bag M

TKR1221

Note: From Bag M

TKR1323

Note: From Bag M

Step P-4

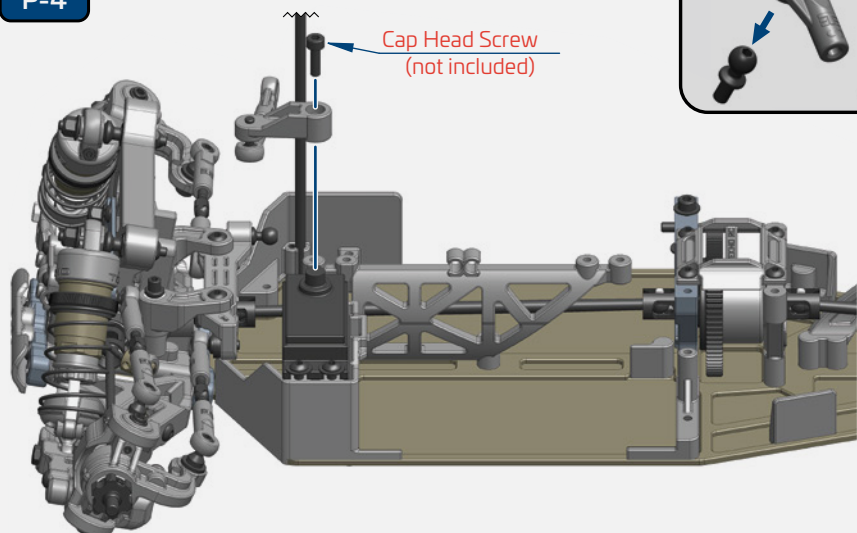

Cap Head Screw
(not included)

Note: Only this angled link can be installed both ways.

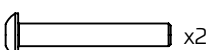

x2

TKR1409
M3x20mm Button Head Screw

TKR6502 - EB410.2 1/10th 4WD Competition Electric Buggy Kit

Parts List

TKR5125 - O-Ring (ESC tray, 3pcs)
TKR5126 - Antenna tube (universal, w/ caps, 5pcs)
TKR5230 - Steering Linkage (M3x18mm threaded rod, 10pcs)
TKR5238 - Steering linkage (M3x30mm threaded rod, 10pcs)
TKR5571M - Wheel Hexes (12mm, steel, lightened, 4pcs)
TKR6206 - Ball Stud (5.5mm, short neck, 6mm thread, 4pcs)
TKR6207 - Ball Stud (5.5mm, long neck, 6mm thread, 4pcs)
TKR6208 - Ball Stud (5.5mm, short neck, 8mm thread, 4pcs)
TKR6212 - Ball Stud (5.5mm, short neck, 12mm thread, 4pcs)
TKR6218 - Ball Stud (5.5mm, long neck, 8mm thread, 4pcs)
TKR6250 - Turnbuckle (M3 thread, 55mm length, 4mm adjustment, 2pcs)
TKR6252 - Turnbuckle (M3 thread, 40mm length, 4mm adjustment, 2pcs)
TKR6253B - Rod End Set (turnbuckles, sway bar, steering, EB410.2)
TKR6270R - Stub Axles (rear, hardened steel, EB410, 2pcs)
TKR6274 - Wheel Nuts (7mm, serrated, gun metal ano, M4, 4pcs)
TKR6280 - Battery Strap Thumb Screw (EB410)
TKR6501B - Chassis (revised, CNC 7075, EB410.2/ET410)
TKR6519B - Bulkhead Set (f/r, revised, EB410.2/ET410)
TKR6523HD - Hinge Pins (inner, 3.5mm f/r, requires TKR6544B, 2pcs)
TKR6525B - Suspension Arms (front, for 3.5mm TKR6523HD pins)
TKR6526C - Bell Cranks, Servo Horns, Ackerman Plate (revised, EB410.2)
TKR6527B - Shock Standoffs (requires TKR6780, EB/ET410, 2pcs)
TKR6530 - Motor Mount Base (CNC, 7075, EB410)
TKR6538 - Chassis Brace, Body Mount Set (EB410)
TKR6539 - Motor Mount Insert (CNC, 7075, EB410)
TKR6540HD - Hinge Pin Brace (CNC, 7075, EB410.2, A Block)
TKR6541HD - Hinge Pin Brace (CNC, 7075, EB410.2, B Block)
TKR6542HD - Hinge Pin Brace (CNC, 7075, EB410.2, C Block)
TKR6543HD - Hinge Pin Brace (CNC, 7075, EB410.2, D Block)
TKR6544B - Hinge Pin Inserts, Wheelbase Shims (req TKR6523HD pins)
TKR6546B - Wing Mount and Bumper (one-piece mount, EB410.2)
TKR6547 - Sway Bar and Bulkhead Acc. (EB410)
TKR6548 - Pivot Balls (5.5mm, flanged, 4pcs)
TKR6553 - Spindles (l/r, EB410)
TKR6555 - Stabilizer Balls (5.5mm, sway bars, aluminum, 4pcs)
TKR6565 - Hinge Pins (outer, front, EB410, 2pcs)
TKR6566 - Hinge Pins (outer, rear, EB410, 2pcs)
TKR6572B - Driveshaft (rear, hardened steel, EB410.2, 2pcs)
TKR6573F - Stub Axles (front, hardened steel, EB410, 2pcs)
TKR6574B - Driveshaft (front, hardened steel, EB410.2, 2pcs)
TKR6576 - Rear Hubs (adjustable Roll Center, L/R, EB410.2)
TKR6584 - Suspension Arms (rear, forward shock mount, EB410.2)
TKR6586 - Side Guard, Servo Mount, Battery Acc. (EB410)
TKR6590 - Sway Bar Mount (rear, EB410.2)
TKR6596 - Kingpin Shoulder Screws (EB410, 4pcs)
TKR6597 - Diff Coupler (f/r, lightened, hardened steel, EB410)
TKR6599 - Tapered Driveshaft (center, rear, 7075, black ano, EB410)
TKR6600 - Tapered Driveshaft (center, front, 7075, black ano, EB410)
TKR6605 - Wing (lexan, pre-cut, EB410)
TKR6608 - Body (0.8mm, EB410)
TKR6610 - Sway Bar Set (rear, 1.5, 1.6, 1.7, 1.8, 1.9mm, EB410)
TKR6623 - Sway Bar Kit (complete front, 1.0, 1.1, 1.2, 1.3, 1.4mm, EB410)
TKR6627 - Steering Rack Bushings (aluminum, EB410, 2pcs)
TKR6629B - Steering Posts (revised, steel, EB410.2, 2pcs)
TKR6634 - Center Diff Support, Top Braces (EB410)
TKR6648 - Spindle Carriers (15°, LRC, L/R, EB410.2)
TKR6649 - Decal Sheet (EB410.2)
TKR6664B - Front Camber Link Plate (revised, aluminum, EB410.2)
TKR6666 - Rear Camber Link Plate (aluminum, EB410.2)
TKR6681 - Shock Tower Set (F/R, EB410.2)
TKR6685 - Rear Body Mount Panels (EB410, 2pcs)
TKR6686 - Body Mount Hook and Loop Tape Set (EB410, 4pcs)
TKR6856 - CV Rebuild kit (f/r, for 2 axles)

Differential List

TKR5144 - Differential O-Rings (6pcs)
TKR6511 - Differential Case (f/c/r, 3pcs, EB410)
TKR6512 - Differential Ring Gear (40t, use with TKR6551)
TKR6513X - Differential Cross Pins (composite, 3pcs, EB410)
TKR6514 - Differential Outdrives (f/r/c, lightened, EB410)
TKR6515 - Differential Seals (3pcs, EB410)
TKR6517 - Differential Shims (5x14mm, hardened, 6pcs, EB410)
TKR6522B - Spur Gear (revised material, 81t, 48pitch, black, EB410.2)
TKR6550 - Differential Gear Set (internal gears only, EB410)
TKR6551 - Diff Pinion (16t, use with TKR6512)

Bearings List

TKRBB040725 - Ball Bearing (4x7x2.5mm, 4pcs)
TKRBB05114 - Ball Bearing (5x11x4, 4pcs)
TKRBB06124 - Ball Bearing (6x12x4, 4pcs)
TKRBB10154 - Ball Bearing (10x15x4, 4pcs)

Shocks List

TKR6701 - Locking Shock Rod End and Spring Perch Set (13mm shocks)
TKR6703 - Shock Shafts (front, steel, EB410, 2pcs)
TKR6704 - Shock Shafts (rear, steel, EB410, 2pcs)
TKR6705B - Shock Piston Set (8x1.2, 8x1.3, flat/flat, 13mm, 4pcs)
TKR6708 - Shock Cartridge Guide Set (CNC, Delrin, 8pcs, EB410/ET410)
TKR6709 - Shock X-rings (8pcs, EB410)
TKR6710 - Shock Body (front, aluminum, hard ano, EB410, 2pcs)
TKR6711 - Shock Body (rear, aluminum, hard ano, EB410, 2pcs)
TKR6712 - Shock/Cartridge Cap & Bushing Set (4pcs each, EB410)
TKR6714 - Emulsion O-ring Set (4x cap seals, 8x emulsion o-rings, for 13mm shocks)
TKR6719A - Shock Adjustment Collars (aluminum, EB410, 2pcs)
TKR6780 - Shock Cap Bushings (requires TKR6527B, EB/ET410, 4pcs)
TKR6787 - Shock Spring Set (front, 1.3x7.75, 3.85lb/in, 45mm, red)
TKR6793 - Shock Spring Set (rear, 1.2x9.38, 2.20lb/in, 53mm, pink)

Hardware List

TKR1201 - M3 Locknuts (black, 10pcs)
TKR1211 - M3 Locknuts (flanged, black, 10pcs)
TKR1221 - M3x8mm Washer (black, 10pcs)
TKR1229 - 6x10x.2 Shims (10pcs)
TKR1235 - Body Clips (angled, 10pcs)
TKR1240 - Lower Shock Mount Screws (2 CW thread, 2 CCW thread)
TKR1245 - Shock Piston Retainer Screw (4pcs)
TKR1248 - M2x4mm Cap Head Screws (black, 10pcs)
TKR1301 - M2.5x6mm Flat Head Screws (black, 10pcs)
TKR1303 - M2.5x10mm Flat Head Screws (black, 10pcs)
TKR1321 - M3x6mm Flat Head Screws (black, 10pcs)
TKR1322 - M3x8mm Flat Head Screws (black, 10pcs)
TKR1323 - M3x10mm Flat Head Screws (black, 10pcs)
TKR1329 - M3x20mm Flat Head Screws (black, 10pcs)
TKR1400 - M3x4mm Button Head Screws (black, 10pcs)
TKR1401 - M3x6mm Button Head Screws (black, 10pcs)
TKR1402 - M3x8mm Button Head Screws (black, 10pcs)
TKR1403 - M3x10mm Button Head Screws (black, 10pcs)
TKR1405 - M3x14mm Button Head Screws (black, 10pcs)
TKR1409 - M3x20mm Button Head Screws (black, 10pcs)
TKR1411 - M3x25mm Button Head Screws (black, 10pcs)
TKR1463 - M2.5x6mm Button Head Screws (black, 10pcs)
TKR1522 - M3x8mm Cap Head Screws (black, 10pcs)
TKR1523 - M3x10mm Cap Head Screws (black, 10pcs)
TKR1601 - M3x4mm Set Screws (black, 10pcs)
TKR1602 - M4x4mm Set Screws (black, 10pcs)
TKR1604 - M3x8mm Set Screws (black, 10pcs)
TKR1609 - M3x3mm Set Screws (black, 10pcs)
TKR1611 - M4x8mm Set Screws (black, 10pcs)

Option Parts

TKR1103 - Turnbuckle Wrench (4mm, 5mm, hardened steel)
TKR1115 - Pivot Ball and Shock Multi-tool (aluminum)
TKR1119 - 5.5mm / 7.0mm Wrench (hardened steel)
TKR1654 - Composite 12mm Hex Adapters (+1mm, 4pcs)
TKR1654X - 12mm Aluminum Hex Adapters (+1mm, aluminum, 4pcs)
TKR5571 - Composite Wheel Hexes (12mm, 4pcs)
TKR5571A - Wheel Hexes (SCT410, 12mm, aluminum, 4pcs)
TKR6503C - Battery Strap (carbon fiber, EB410)
TKR6524B - Suspension Arms (rear, for 3.5mm TKR6523HD pins)
TKR6563A - Aluminum Servo Horn (25T, standard, low profile, M3 clamp, EB410)
TKR6598C - Steering Top Plate (carbon fiber, EB410)
TKR6635C - Center Diff Top Plate and Fan Mount (carbon fiber, EB410)
TKR6703T - Shock Shafts (front, steel, TiNi coated, EB410, 2pcs)
TKR6704T - Shock Shafts (rear, steel, TiNi coated, EB410, 2pcs)
TKR6712A - Shock Caps (7075, emulsion, black ano, 2pcs)
TKR6705 - Shock Piston Set (2x1.7, 2x1.8, flat/flat, 13mm, 4pcs)
TKR6731 - Shock Pistons (CNC, 2x1.7, 2pcs)
TKR6732 - Shock Pistons (CNC, 2x1.8, 2pcs)
TKR6735 - Shock Piston Blanks (CNC, flat/flat, 13mm, 4pcs)
TKR6736 - Shock Pistons (CNC, 8x1.1, flat/flat, 13mm, 2pcs)
TKR6737 - Shock Pistons (CNC, 8x1.2, flat/flat, 13mm, 2pcs)
TKR6738 - Shock Pistons (CNC, 8x1.3, flat/flat, 13mm, 2pcs)
TKR6783 - Shock Spring Set (front, 1.3x9.5, 2.95lb/in, 45mm, pink)
TKR6784 - Shock Spring Set (front, 1.3x9.0, 3.16lb/in, 45mm, green)
TKR6785 - Shock Spring Set (front, 1.3x8.5, 3.41lb/in, 45mm, yellow)
TKR6786 - Shock Spring Set (front, 1.3x8.13, 3.62lb/in, 45mm, orange)
TKR6794 - Shock Spring Set (rear, 1.2x8.75, 2.41lb/in, 53mm, green)
TKR6795 - Shock Spring Set (rear, 1.2x8.25, 2.6lb/in, 53mm, yellow)
TKR6796 - Shock Spring Set (rear, 1.2x7.75, 2.82lb/in, 53mm, orange)
TKR6797 - Shock Spring Set (rear, 1.2x7.38, 3.02lb/in, 53mm, red)

Set Up Information

The purpose of making adjustments is to make the car go faster around the track, or to make it more controllable, or both if possible. A car that's easier to drive should produce lower, more consistent lap times. It will also inspire more confidence in the driver, which is always good when nerves start getting the best of you.

Before you start thinking about changing your car's setup, consider these two things: First, is the car in perfect working order? Be sure that all of the suspension components operate freely without excessive play, and that the car isn't tweaked. Binding and worn out parts will result in poor performance and inconsistent handling. Second, always consider tires before making other adjustments. Time spent trying to get the vehicle to work with the wrong tires mounted will be wasted time. Without the right tires, even a great setup won't be a winning setup.

Ride Height

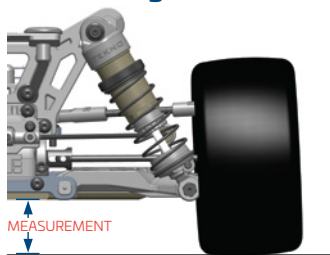

Ride height is the distance from the bottom of the chassis to the running surface. Ride height should only be checked and adjusted with your vehicle ready to run (i.e. with battery installed/body on). Ride height is the first adjustment to be made and should be set with a ride height measurement tool. Measurements should be taken from the flat parts of the chassis, front and rear. Be sure to measure the front ride height at a point before the kick up in the chassis starts. To measure ride height, first make sure the suspension is completely free, then simultaneously compress the front and rear all the way down and let the vehicle settle. Take your measurement from that position. Use the shock spring adjustment collars to raise or lower the ride height to your desired setting. 18 - 20mm front and rear is a good starting point.

Camber

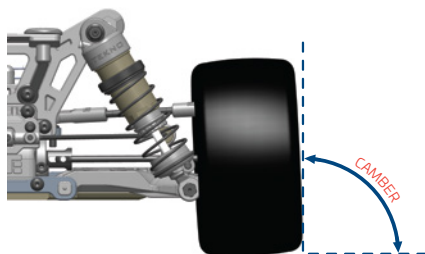

Static camber affects the car's side to side traction. More negative camber front and rear quickens rotation in corners. Less negative camber will make the vehicle easier to drive but you may give up some responsiveness (i.e. steering). To set your static camber have your vehicle at ride height (see above) and adjust the camber links until desired angle is achieved. Please note that a large adjustment of front camber will affect front toe and you may have to readjust the toe and then re-check front camber again. A good starting measurement for camber is 1-2 degrees in the front and 1.5-2.5 degrees in the rear.

Front Toe

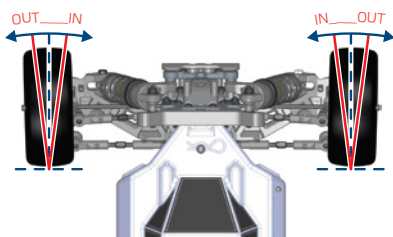

Front toe is used to describe the angle in which the front wheels point when looking down at them from the top of a vehicle. You will always use some amount of toe out. Toe-out will affect how your vehicle enters and exits corners. More toe out will result in more off-power steering and less on-power steering and less toe out will have the opposite results. To set your front toe, have your vehicle at ride height (see above) and adjust the steering links until desired angle is achieved. Please note that a large adjustment of front toe will affect front camber and you may have to readjust the camber and then re-check front toe again. A good starting point is approximately 1-2 degrees of toe out.

Ackermann Effect

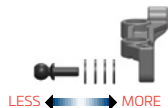

Think of Ackermann as active toe when the steering moves from left to right. More ackermann effect makes more toe out at full turn and produces more steering off-power. Less ackermann effect makes less toe out at full turn and produces more steering on-power. A good starting point is 4 washers behind the ball stud (2mm).

Bumpsteer

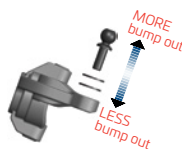

Think of bump steer as active toe when the suspension compresses or rebounds. To adjust bump steer you have to change the angle of the steering link. This is accomplished by adding or removing washers under the ball end on the steering spindles. Anytime you change camber link locations, front arm pills, front arm spacers, or Ackermann you will need to check and possibly adjust your bumpsteer. It's best to start with zero bumpsteer or slight bump out.

Drop

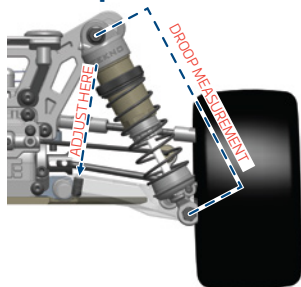

Drop is the measured amount of down travel in the suspension. It is measured from the shock mounting points while the vehicle is up on a stand allowing the arms to hang freely and is adjusted by turning the drop screw located in the suspension arms front/rear. This screw limits the suspension travel by providing a stopping point against the chassis. Left and right sides should always be equal, however the front and rear of the vehicle can have different values. Drop affects all aspects of chassis performance, including: braking, acceleration, jumping, traction and bump handling. A good starting drop measurement is 78mm front and 89mm rear.

Set Up Information

(continued)

Differentials



Front: Changing front diff oil affects overall steering response. Thinner can increase off-power steering but the vehicle may be twitchy and harder to drive. Thicker can increase on power steering and stability. We recommend 10k to 20k in the front diff.

Center: Changing center diff oil affects the front-to-rear drive balance. Thicker will reduce off-power steering and on-power rear traction but increases on-power steering and acceleration if traction is available. Thinner will increase off-power steering and on-power rear traction but reduce on-power steering and acceleration. We recommend 20k to 40k in the center diff.

Rear: Thinner rear diff oil increases off-power steering and reduces traction into a corner. It also reduces on-power steering and increases traction out of a corner. Going too thin will make your vehicle inconsistent, however. Thicker rear oil will have opposite effects, and once again, going too thick will make the vehicle inconsistent. We recommend 7k to 12k in the rear diff.

Wheelbase Adjustments

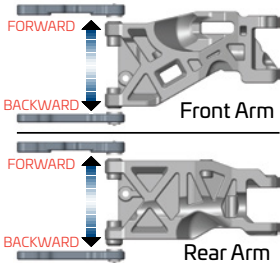

Changes to wheelbase can affect the overall handling of your vehicle, since it adjusts the distribution of weight on the wheels as well as the angle of the driveshafts. Shortening the wheelbase at the rear will give you more steering into a turn and off power, less steering out of a turn and on power. Lengthening the wheelbase at the rear will yield the opposite results.

Shortening the wheelbase in the front will land jumps a little better and lengthening it will be better through small bumps. In general a longer wheelbase is better on open and/or bumpy tracks and a shorter wheelbase is better on tighter technical tracks.

Springs

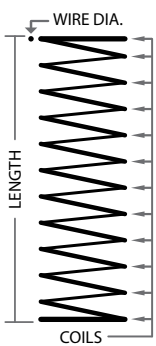

PART#/COLOR	F / R	WIRE DIA.	COILS	LENGTH	RATE
TKR6783	Front	1.3	9.5	45mm	2.95
TKR6784	Front	1.3	9.0	45mm	3.16
TKR6785	Front	1.3	8.5	45mm	3.41
TKR6786	Front	1.3	8.13	45mm	3.62
TKR6787	Front	1.3	7.75	45mm	3.85
TKR6793	Rear	1.2	9.38	53mm	2.20
TKR6794	Rear	1.2	8.75	53mm	2.41
TKR6795	Rear	1.2	8.25	53mm	2.60
TKR6796	Rear	1.2	7.75	53mm	2.82
TKR6797	Rear	1.2	7.38	53mm	3.02

Softer springs will increase traction through the turns by allowing more roll, slow down the responsiveness of the vehicle, and can be better in the bumps. Stiffer springs will increase corner speed if traction is available and will also tend to jump and land better. Once you find a set of springs you like you will typically only change them for tracks with dramatically different conditions.

Pistons

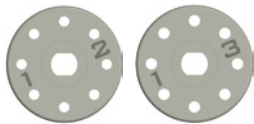

Pistons with smaller or fewer holes work well for smoother tracks with large jumps, and pistons with larger holes or more holes, work well for rougher tracks with less jumps. Smaller hole pistons will typically use thinner oil than larger hole pistons. Shock oil is also affected by the ambient temperature so a change in viscosity might be necessary with a change of 5°C or ~10°F.

Sway Bars

Part#	F/R	Size
TKR6623	Front	1.0mm
TKR6623	Front	1.1mm
TKR6623	Front	1.2mm
TKR6623	Front	1.3mm
TKR6623	Front	1.4mm
TKR6610	Rear	1.5mm
TKR6610	Rear	1.6mm
TKR6610	Rear	1.7mm
TKR6610	Rear	1.8mm
TKR6610	Rear	1.9mm

Sway bars are used to adjust a vehicle's lateral grip by resisting chassis roll. A thicker bar decreases roll more than a thinner bar will. More roll means more grip and less roll means less grip. The front sway bar affects mainly off-power steering at corner entry. The rear sway bar affects mainly on-power steering and stability in mid-corner and at corner exit.

Bearing Chart

	TKRBB040725 – Ball Bearings (4x7x2.5mm, sold in pack of 4pcs) Bearings for the bellcrank/ackerman plate. 8pcs required in kit.
	TKRBB05114 – Ball Bearings (5x11x4, 4pcs) Diff pinion support bearings for the front/rear transmission housings. 4pcs required in kit.
	TKRBB06124 – Ball Bearings (6x12x4mm, 4pcs) Bearings for outside of steering blocks and outer rear hub carriers. 4pcs required in kit.
	TKRBB10154 – Ball Bearings (10x15x4mm, sold in pack of 4pcs) Bearings for all three diffs. Also inner front steering blocks/rear hub carriers. 10pcs required in kit.

* For bearing maintenance, please refer to page 30.

Gearing Recommendations

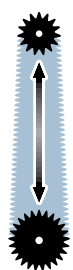

Motor (w/2 cell)	Small Track (48pitch pinion/spur)	Large Track (48pitch pinion/spur)	Small Track (32pitch pinion/spur)	Large Track (32pitch pinion/spur)
	(50-80 ft Straight)	(80-150 ft Straight)	(50-80 ft Straight)	(80-150 ft Straight)
5.5T	18/81 tooth	19/81 tooth	12/53 tooth	12-13/81 tooth
6.5T	19/81 tooth	20/81 tooth	12-13/53 tooth	13/53 tooth
7.5T	20/81 tooth	21/81 tooth	13-14/53 tooth	13-14/53 tooth
8.5T	21/81 tooth	22/81 tooth	14/53 tooth	14-15/53 tooth
10.5T	22/81 tooth	23/81 tooth	14-15/53 tooth	15/53 tooth
13.5T	22/81 tooth	24/81 tooth	14-15/53 tooth	15/53 tooth

This chart shows the recommended starting ratios for the common motor winds. Please consult the motor/esc manufacturers recommended settings to ensure you start with the best final drive ratio (FDR) for your equipment. When setting your mesh you want to be able to *slightly* rock the spur gear back and forth without moving the pinion gear. Tekno RC is not responsible for damage done to your electronic equipment or gears due to improper gearing or mesh.

Maintenance:

Performing regular maintenance will greatly improve your on track consistency and also extend the life of your vehicle. Going through critical areas of the vehicle regularly will also allow you to find possible issues before they become a problem that may cost you a race. Follow the guidelines below for maximum performance.

Bearing Maintenance:

Bearings should always be smooth and free in order to perform their function. We recommend inspecting and cleaning each bearing on a regular basis. It will be necessary to break down parts of the vehicle in order to inspect them properly. The procedures below should be done every couple of weeks or prior to an important race.

1. Inspect the outer seals for any visible damage and check the rolling resistance of each bearing.
2. If any bearing does not spin freely, then take the following steps to clean them.
3. Spray the bearing with motor spray and spin it again to remove any debris trapped inside. Repeat if necessary. If the bearing does not start to spin freely after cleaning, then they may need to be replaced.
4. Allow the clean bearing to dry or blow into the bearing with compressed air to speed up the drying process.
5. Oil each bearing with a proper bearing lubricant. One or two drops is enough.

Shock Maintenance:

When comparing the left and right shocks of the front end, they should feel identical. Same goes for the rears. The procedures below should be done every race day to make sure they are leak free and operating correctly.

1. After removing the shocks from the vehicle, remove the springs and inspect each shock for visible leaks (build up of debris at the bottom of the shock shaft or visible oil).
2. If the shock binds when pushing the shaft through its stroke, then the shaft may be bent and will need to be replaced.
3. If the shocks from left to right do not feel consistent when compared to each other, or have built up too much air inside (feel empty when pushing the shaft through its stroke), then you will need to rebuild them following the steps outlined on page 19 of this manual.

Hinge Point & Drive Line Maintenance:

Checking the hinge points while the shocks are removed from the vehicle is the best time to inspect these parts. The other items to inspect are the camber links, steering links and drive shafts. Follow the steps below every couple of weeks in order to keep the vehicle performing at maximum.

1. With the shocks off the vehicle, check the movement of the arms, hubs and spindle carriers. They should move freely. If there is a bind, then the inner or outer hinge pin may be bent and would need to be replaced. The arms should not have any play when twisted or moved in any direction against the hinge points. If there is excessive slop present, then the arms or hubs may be worn and will need to be replaced.
2. Remove the camber links, steering links and servo link from the vehicle. Check the movement of the spindles to see if they turn freely. If they don't, then check the kingpin shoulder screws to see if they are tightened down too far. Also, check for slop. If there is excessive slop present, then the spindle carriers may need to be replaced.
3. Check the steering rack to make sure it moves freely. If it binds, then the screws holding the Ackermann or the steering posts could be too tight. If they still bind, then check the bearings and follow the steps above to clean them.
4. After re-installing the camber links, steering links and servo link, check the movement of the rod ends on the ball studs. If they have excessive slop or are binding, then they may need to be replaced.
5. Check the drive shafts by rotating them. Look for any wobbles. If they are bent, replace them immediately.
6. With the drive shafts removed, check for slop in the CV area. If it is present, then reposition the CV pin to another fresh hole, re-lubricate and install back into the vehicle.

Differential Maintenance:

Properly maintained differentials are essential for a smooth operating vehicle. Check all three diffs regularly to make sure they are filled and operating as designed.

1. Remove each diff and verify the differential action is happening and is smooth. If there is any notchy feel to them, follow the steps below to rebuild them.
2. Open the diff and pour out the oil. Remove the gears and pins to release the outdrives. Then remove the seals. Inspect everything to make sure there are no damaged parts. If the seals are old or show any signs of degradation, replace them immediately. Re-lubricate the seals and outdrives, then rebuild the diff following the steps on page 3 and 4.



Tekno RC
10755 Scripps Poway Pkwy #598
San Diego CA 92131
USA

www.teknorc.com

