

# VIPER 9901

1/8 ON ROAD SCALE

INSTRUCTION  
MANUAL

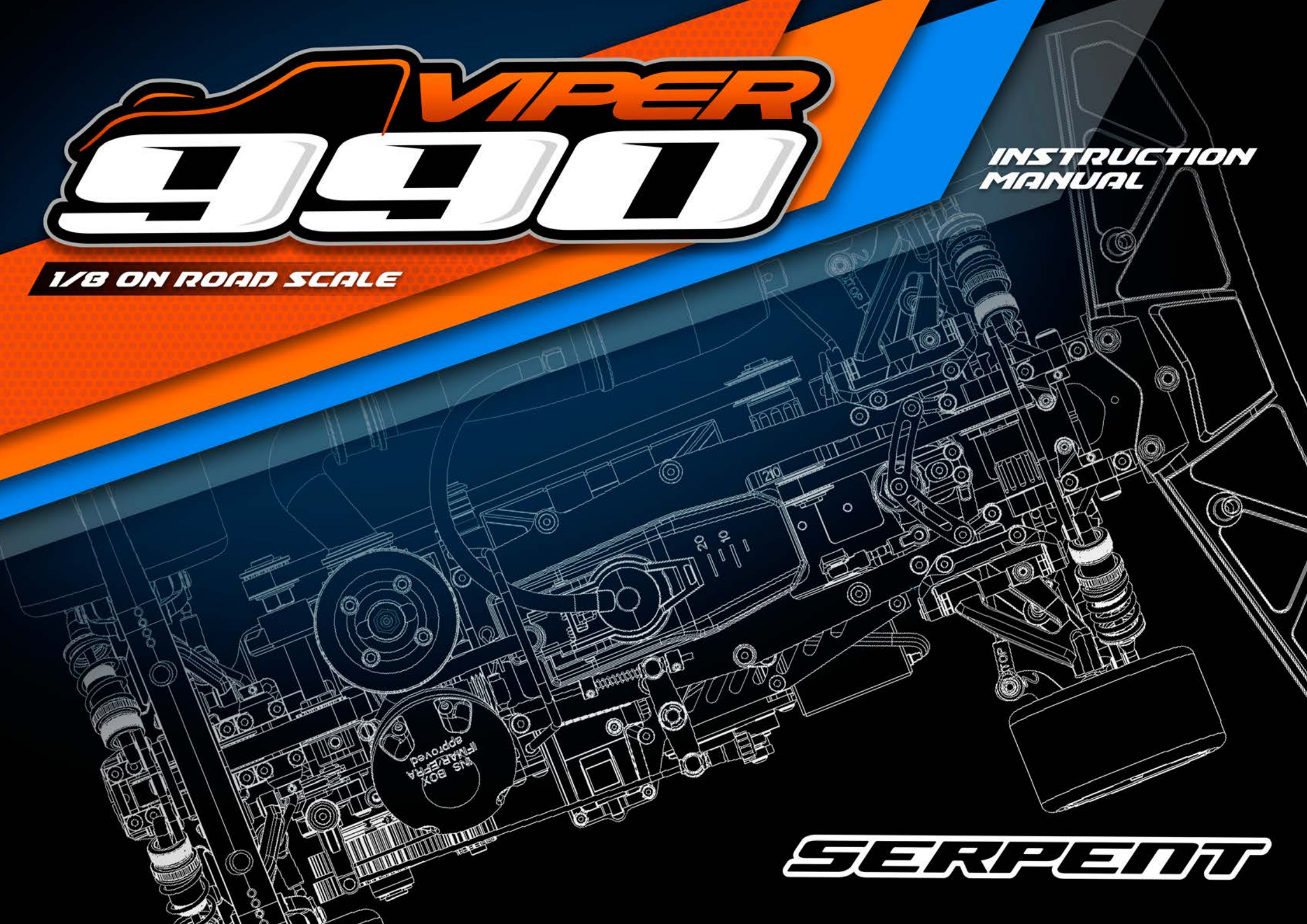

SERPENT



## **INTRODUCTION**

The Serpent Viper 990 is designed to be a world champion, while still being easy to use, assemble, and set up. The Serpent Viper 990 offers state of the art specifications and leads the way in chassis design, using all the knowledge we have from 1/8 scale racing into this design too. Continuously pushing the performance envelope, Serpent's engineers have added new and innovative features that help take your Serpent Viper 990 into the winner's circle.

Designed by Michael Salven

Team Serpent  
Multiple World Champions

## **INSTRUCTIONS**

Serpent's long tradition of excellence extends to the instruction manuals, and this instruction manual is no exception. The easy-to-follow layout is richly illustrated with 3D-rendered full-color images to make your building experience quick and easy. Following the instructions will result in a well-built, high-performance race-car that will soon be able to unleash its full potential at the racetrack. The kit includes bags, with bag numbers, which refer to the same step in the manual. Open only the indicated bag(s) per step and finish that part of the assembly. Remaining parts will be needed later on in the assembly process.

## **PLASTIC PARTS**

The Serpent moulded parts are very durable and hard. When assembling longer screws in new composite parts, make sure to use new hex bits in your (power) tools. Pre-threading also helps to avoid screw damage.

## **SETUP**

In certain assembly steps you need to make basic adjustments, which will give you a good initial setup for your Serpent Viper 990. Fine-tuning the initial setup is an essential part of building a high-performance racecar like your Serpent Viper 990.

## **EXPLODED VIEWS AND PARTS LIST**

The exploded views and parts lists for the Serpent Viper 990 are presented in the Reference Guide section in the back of this manual. The exploded views show all the 990 parts of a particular assembly step along with the Serpent part number and hotlink to the Serpent website. Part numbers in orange indicates that this part is an optional. Optionals part names and numbers are showed below.

## **CUSTOMER SERVICE**

Serpent has made a strong effort to make this manual as complete and clear as possible. Additional info may be published in our website: [www.serpent.com](http://www.serpent.com) or you may ask your dealer or the Serpent distributor for advice, or email Serpent direct: [info@serpent.com](mailto:info@serpent.com). The Serpent Facebook, Twitter and Youtube pages give additional means of support and communications.

## **SAFETY**

Read and take note of the 'Read this First section' before proceeding to assemble the car-kit. This car-kit is intended for persons aged 16 or older.

## **READ THIS FIRST!**

- This is a highly technical hobby product, intended to be used in a safe racing environment. This car is capable of speeds in excess of 80 km/h or 50mph. Please follow these guidelines when building and operating this model.
- Parental guidance is required when the builder/user of this car is under 16.
- Follow the building instructions. If in doubt, contact your dealer or importer.
- Be sure to use the proper tools when assembling the car. Always exercise caution when using electric tools, knives and other sharp objects.
- Be careful when using liquids like lubrication oil, fuel or glue. Do not swallow.
- Follow the manufacturer's instruction in case you experience irritation after using the product.
- Be careful when operating the car. Stay away from any rotating parts such as wheels, gears and transmission. Stay away from motor, engine and exhaust pipe system or speedo during and immediately after use, as these parts may be very hot. We advise to use protective hand gloves.
- Only operate this car in a safe environment, like a special racing track or a closed parking lot. Avoid using this car on public roads, crowded places or near infants.
- Before operating this car, always check the mechanical status of the car. Also check that the transmitter and receiver frequencies correspond and are not used by any other racer at the same time. Check that the batteries of the transmitter and receiver- are fully charged.
- After use, always check all the mechanics of the car. We advise to clean the car immediately after use, and inspect the parts for wear or fractures. Replace when necessary. Do not use water, methanol, thinner or other solvents to clean the car.
- Empty the fuel tank (depending on model) if needed and disconnect the receiver battery.
- Store the car in a dry and heated place to avoid corrosion of metal parts.
- Avoid using this car in wet conditions as the water will cause corrosion on the metal parts and bearings and these parts will cease to function properly. If driven in the wet, ensure that all the electric equipment is waterproofed and after use, that all moving parts are dried immediately.

## **CONTENTS**

•		
•	<b>REAR ASSEMBLY</b>	<b>4</b>
•	<b>GEARBOX ASSEMBLY</b>	<b>16</b>
•	<b>FRONT I ASSEMBLY</b>	<b>19</b>
•	<b>RADIO ASSEMBLY</b>	<b>26</b>
•	<b>FRONT II ASSEMBLY</b>	<b>33</b>
•	<b>SHOCKS ASSEMBLY</b>	<b>37</b>
•	<b>CLUTCH ASSEMBLY</b>	<b>42</b>
•	<b>FINAL ASSEMBLY</b>	<b>44</b>
•	<b>EXPLODED VIEWS</b>	<b>50</b>
•	<b>TEAM SERPENT NETWORK</b>	<b>60</b>

## LINES DESCRIPTION

Each step contains a variety of numbers, lines, and symbols. The numbers represent the order in which the parts should be assembled. The lines are described below.



Step number; the order in which you should assemble the indicated parts



Length after assembly



Assembly path of one item into another



Group of items (within lines) should be assembled first



Direction the item should be moved



Glue one item to another



Connect one item to another



Gap between two items



Press/Insert one item into another

## ICONS DESCRIPTION

Each step contains a variety of symbols described below.



Carefull, read and check very well.



Apply a small amount of cyano glue. Use wear protection for eyes and hands.



Detail view to explain assembly or order of parts better.



Default set-up: This symbol indicates the default setup.



Grease: apply a small amount of grease to the parts shown.



Silicone grease: apply a small amount of grease to the parts shown.



Thread lock: apply a small amount on the parts shown. Before to apply the threadlock, make sure to degrease the parts very well, as otherwise the threadlock will not work.



Silicone oil: use the indicated silicone oil for the shocks and differentials.



Oil: apply a small amount of oil to the parts shown.



Left and right parts should be assembled in the same way.



Parts or items not included in the kit.



Optional part, not standard in the kit.

## STEP 1

BAG 1

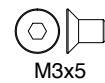
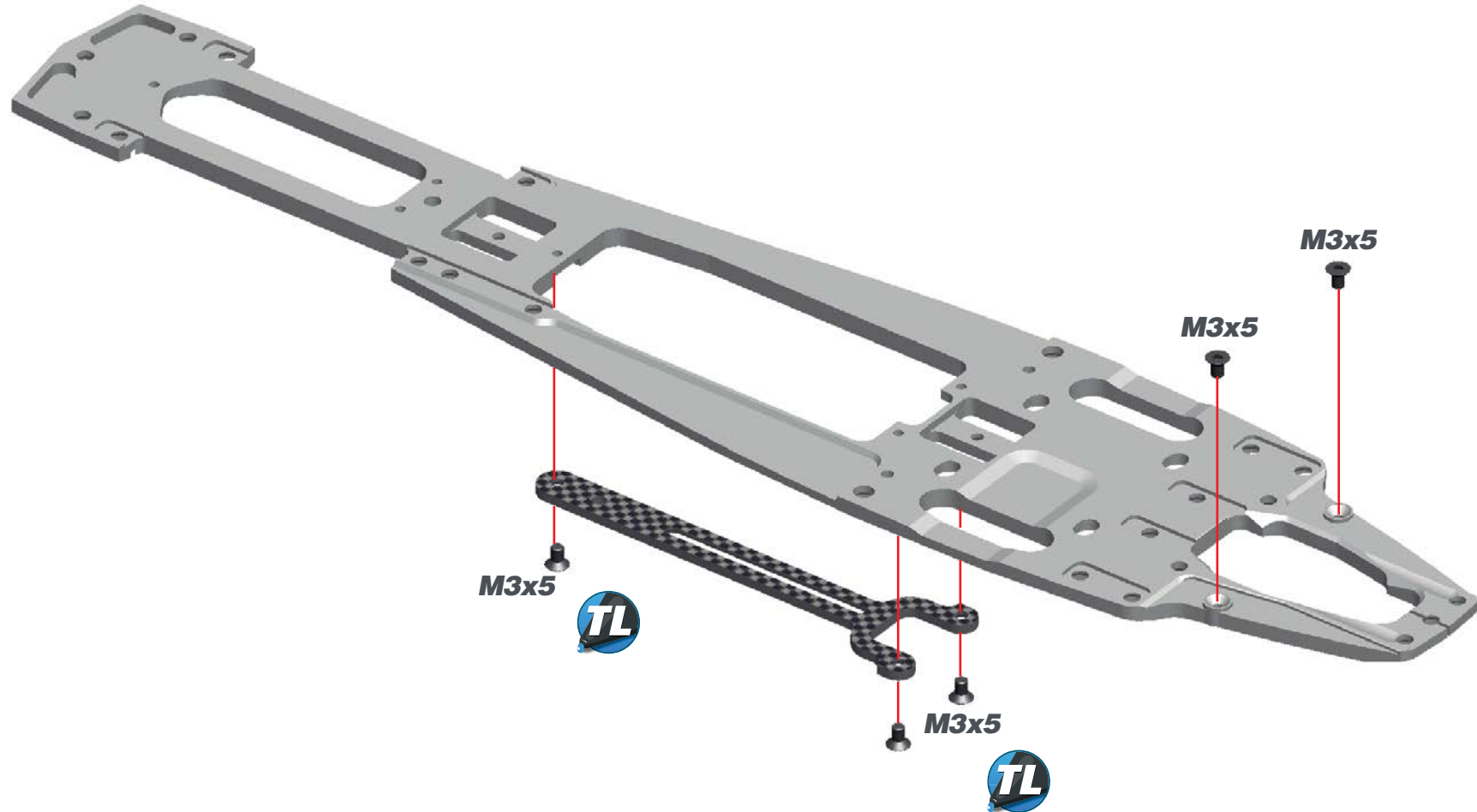



STEP 2

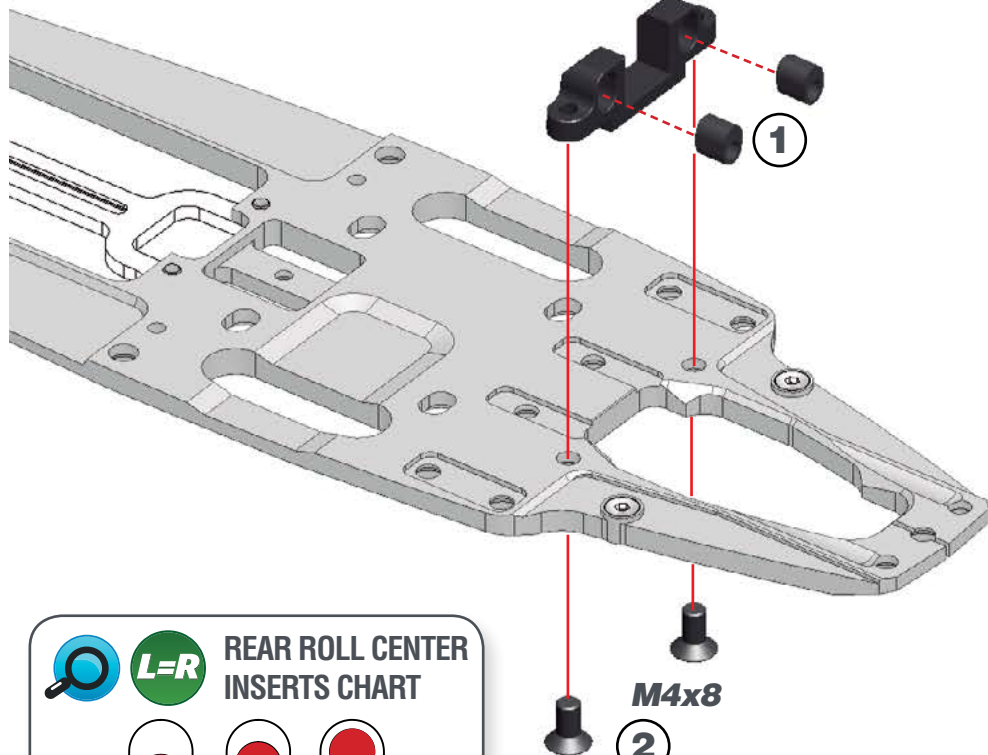



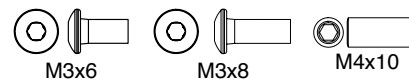
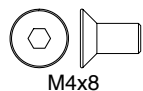
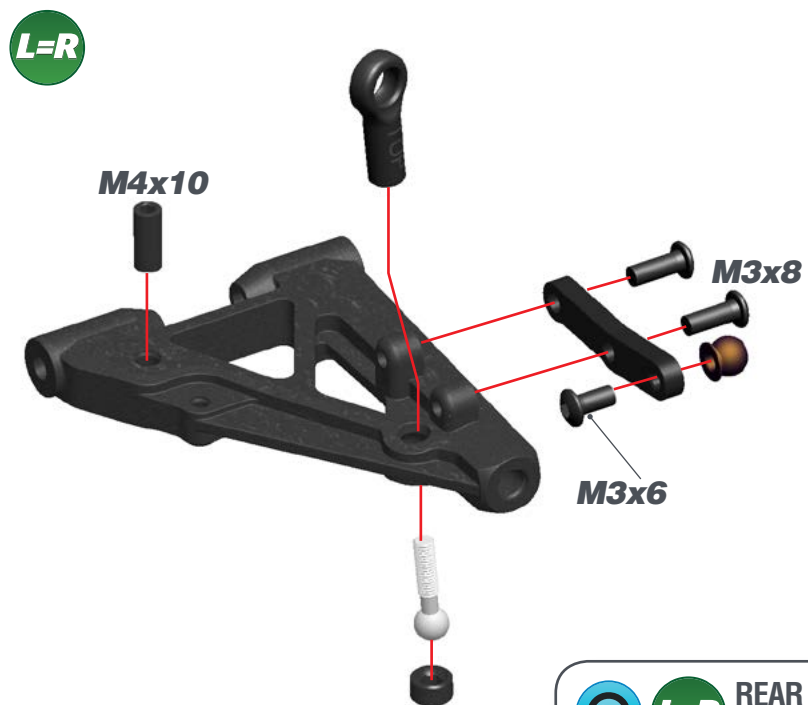

STEP 3

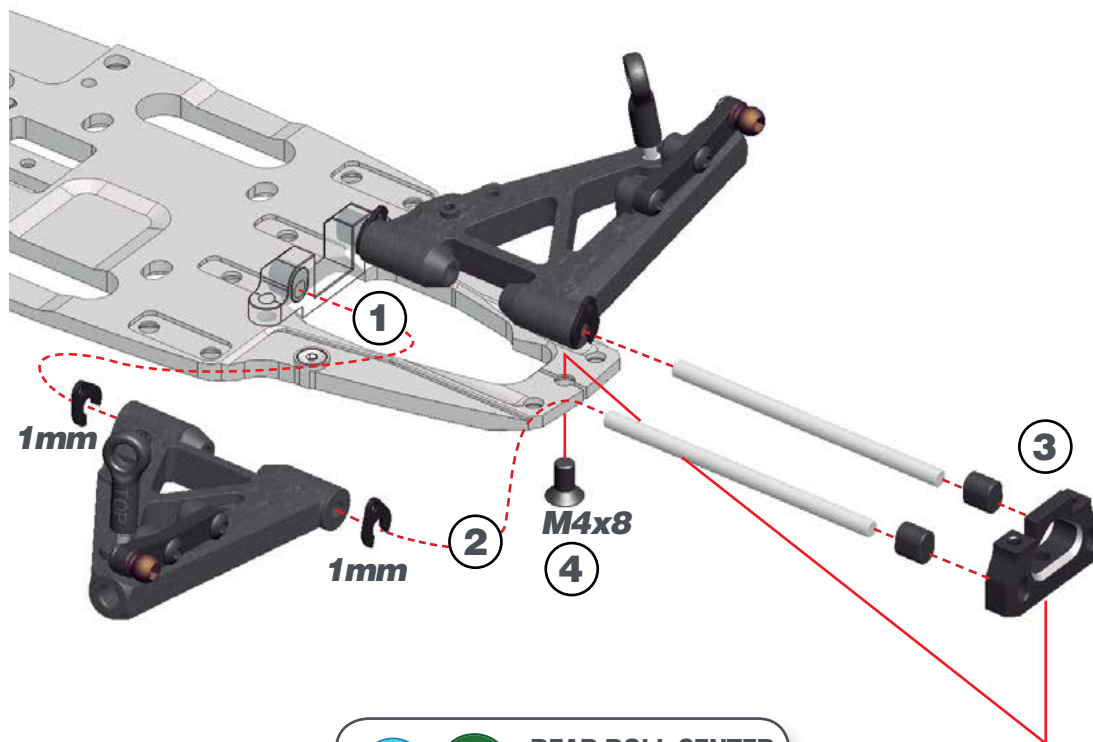

STEP 4



 **L=R** REAR ROLL CENTER  
INSERTS CHART

  



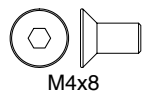

STEP 5

BAG 2

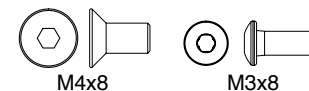
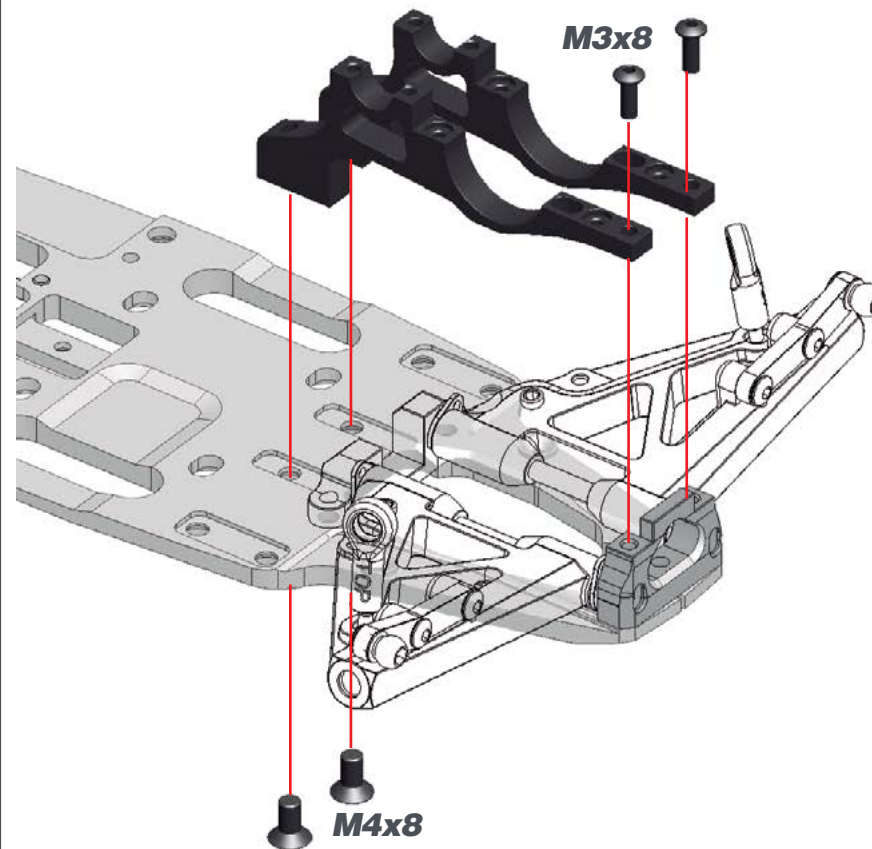



STEP 6

STEP 7



**REAR SOLID AXLE EXCENTERS**  
 Note that the rear solid axle excenters are not symmetrical and are marked with L (=left) and R (=right).

**LEFT**      **RIGHT**

**REAR BELT TENSION**  
 Use the central slot as starting position

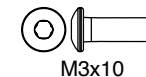
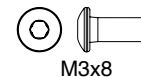
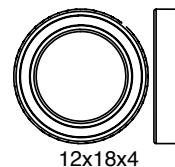
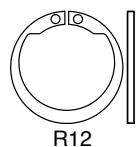
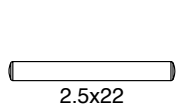
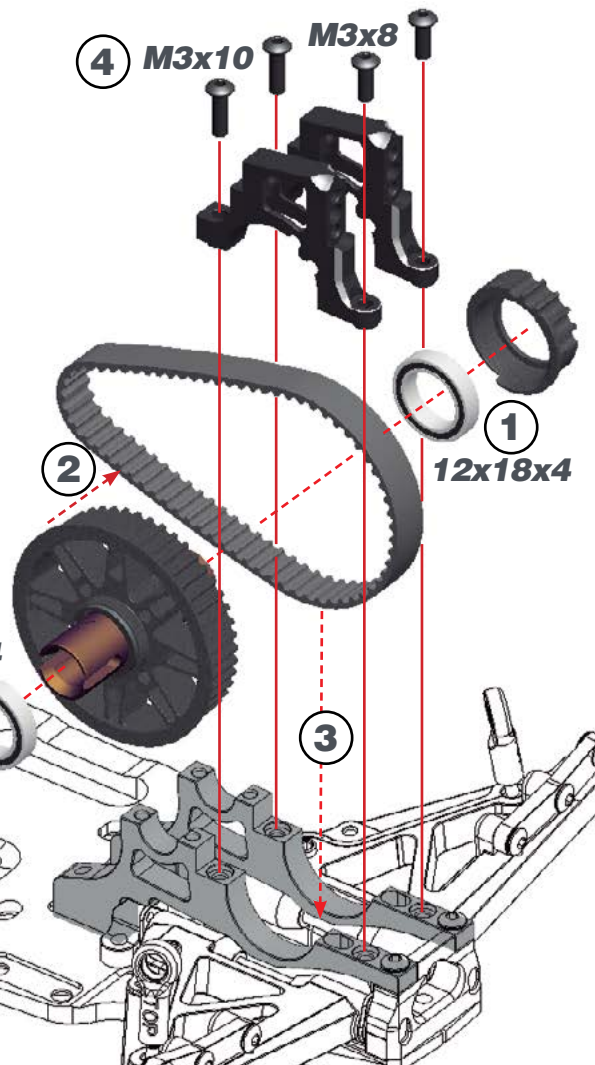

STEP 8

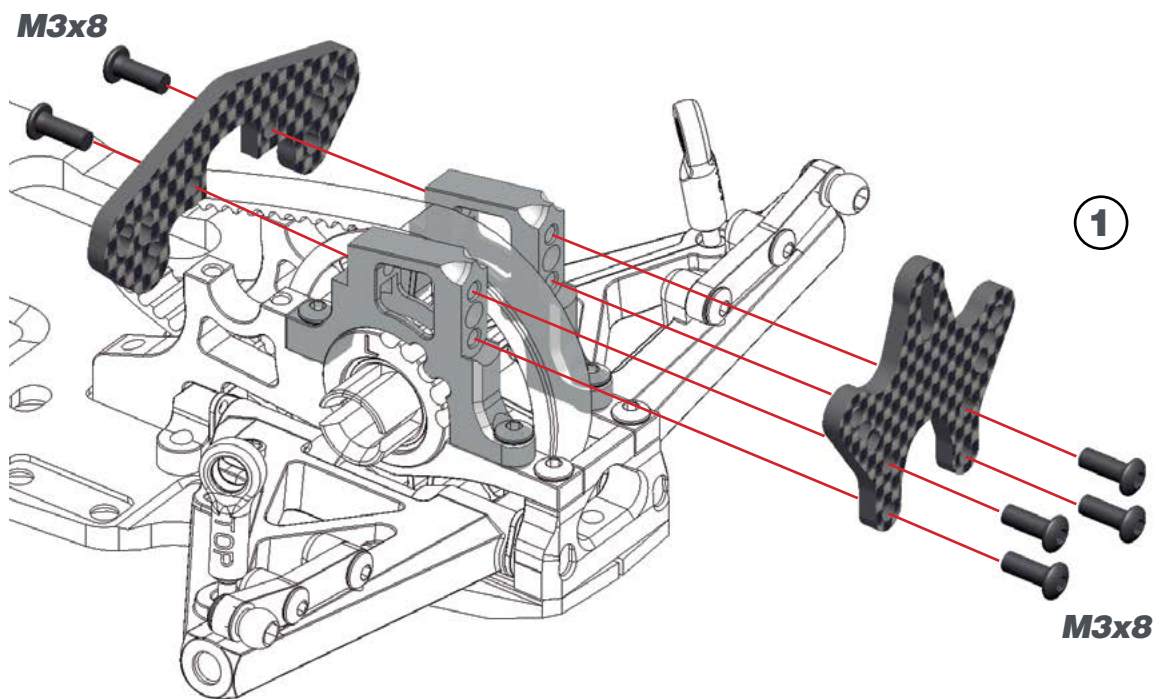

STEP 9

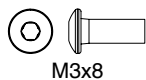



STEP 10

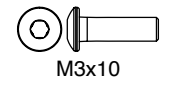
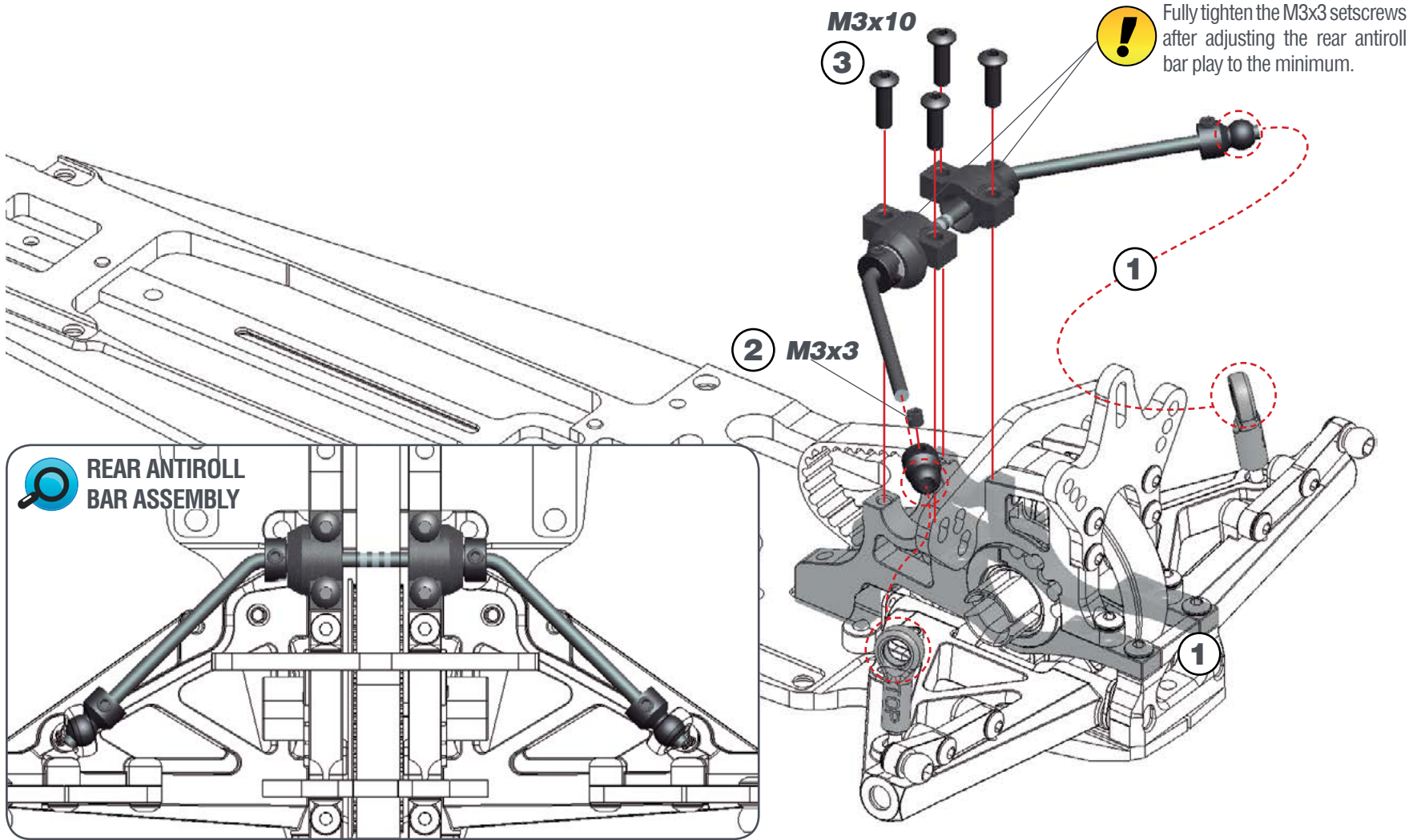

**STEP 11**

**BAG 3**

**11.1**



**11.2**

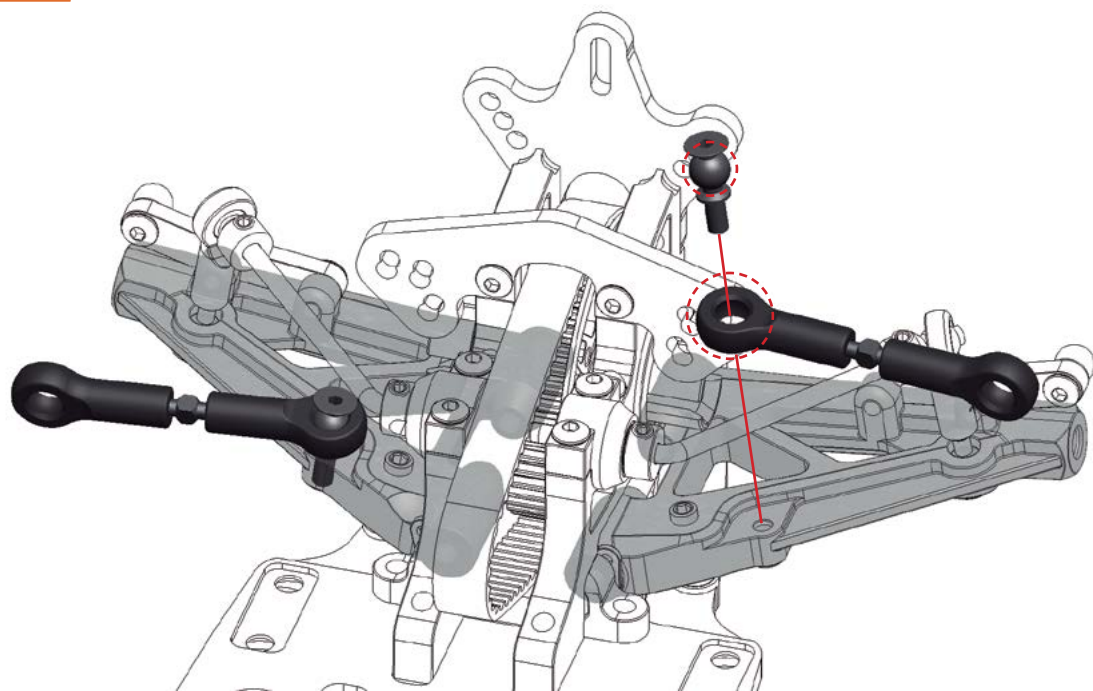

**STEP 12**

**12.1**



**12.2**

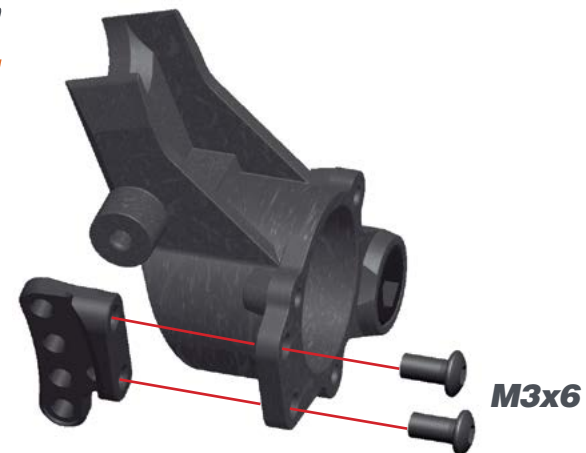



M3x6

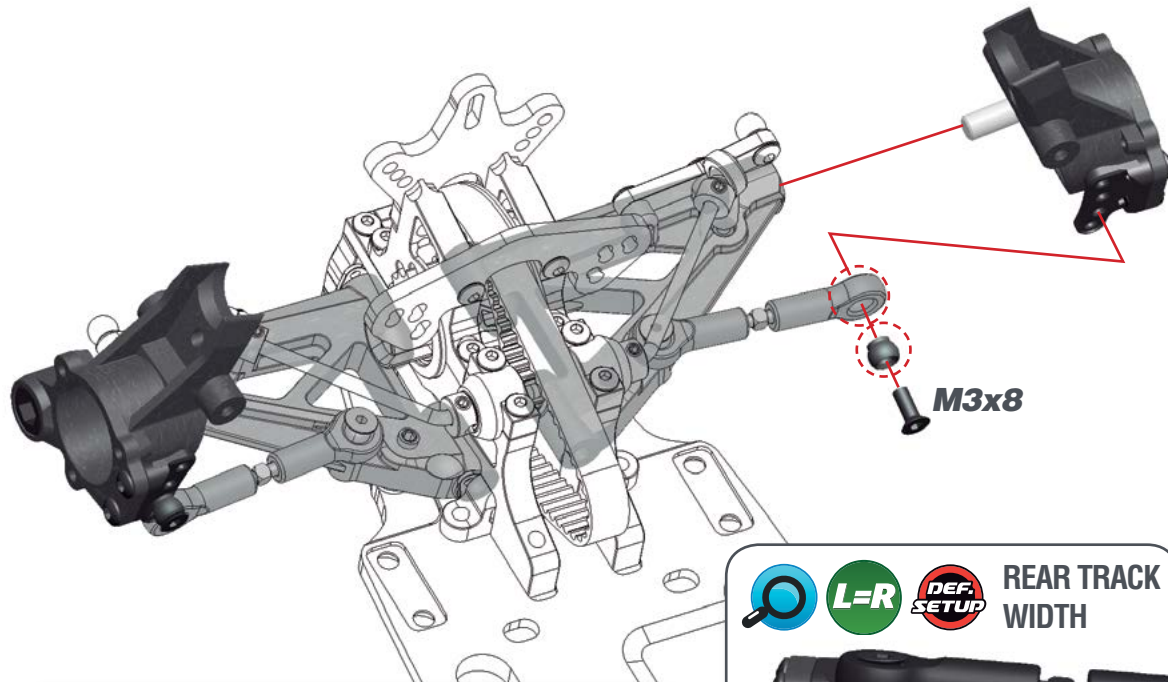

STEP 13





Note the orientation of the pivot ball as it has a neck in one side.



   **REAR TRACK WIDTH**



2 mm

  **REAR REACTIVE STEERING SYSTEM**

Serpent 990 introduce the Active rear toe-in. It brings a new dimension to setup changing the toe-in characteristics of the rear tires under rolling effect. It allows to run less static toe-in and still have a good traction coming out of the corner.

Serpent RRS System brings the possibility to adjust the amount of toe-change over the suspension travel from zero to positive or negative toe-change depending on the linking point selected as explained below:



 Toe in will increase under acceleration (compression) and will decrease under braking (extension).

 Toe in will not change over the suspension travel.

 Toe in will decrease under acceleration (compression) and will increase under braking (extension).



**STEP 14**

**14.1**

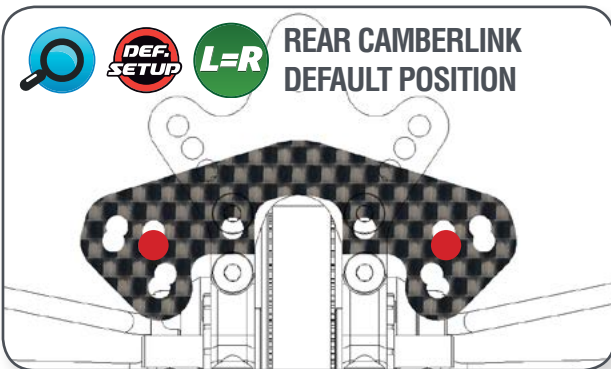
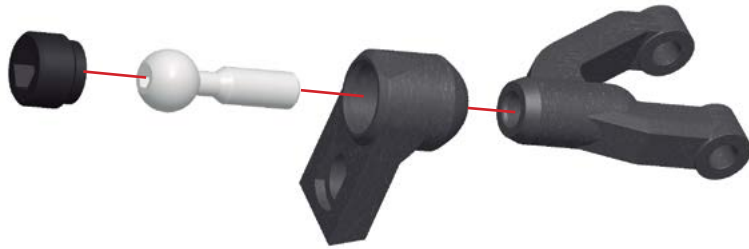

**14.2**

**REAR UPPER WHSIBONE ANGLE**

L=R

Serpent introduces a new way to adjust the height of the upper pivot on the upright. By changing the excenter, it is possible to move the position up or down by 1.5mm as well as using a “neutral” position.

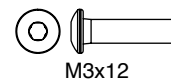
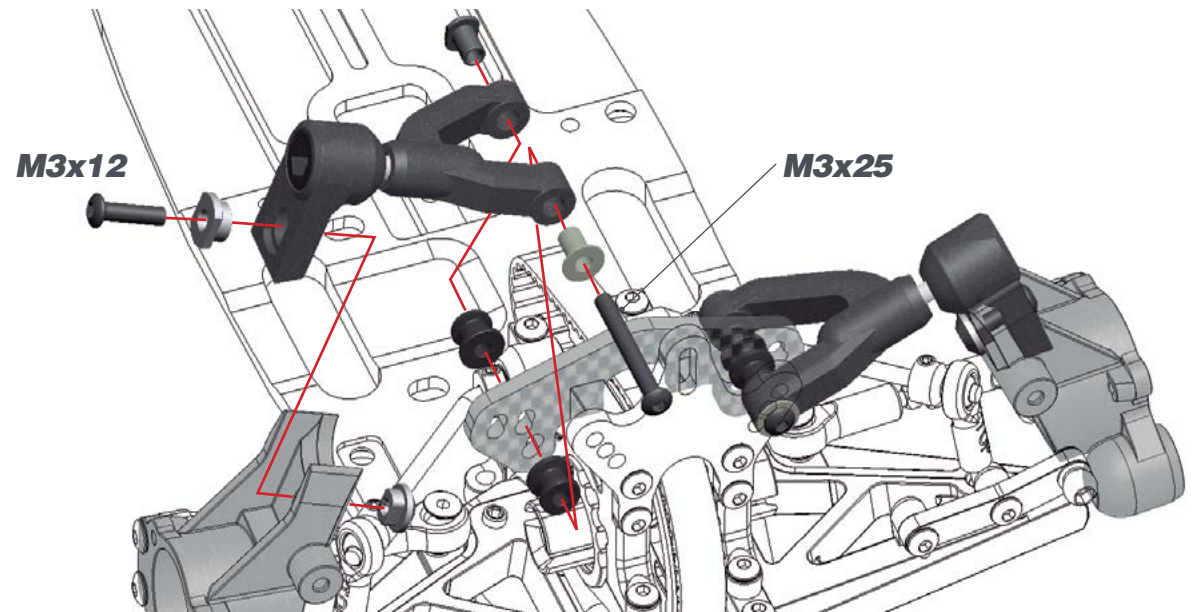
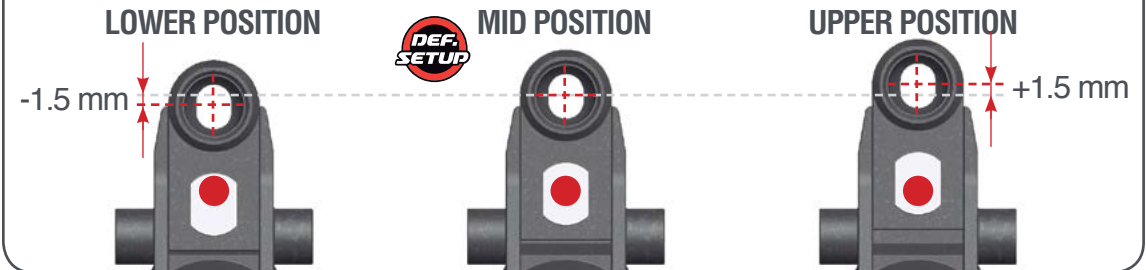

STEP 15 BAG 4

15.1

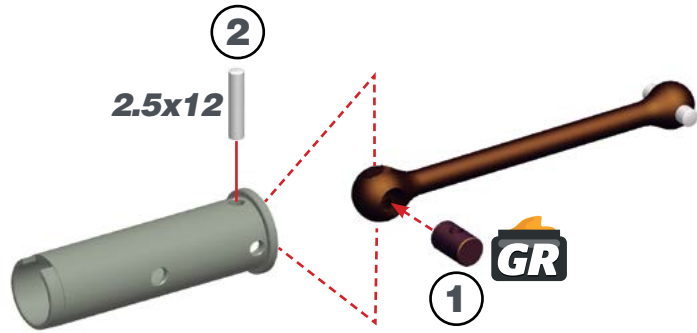

15.2

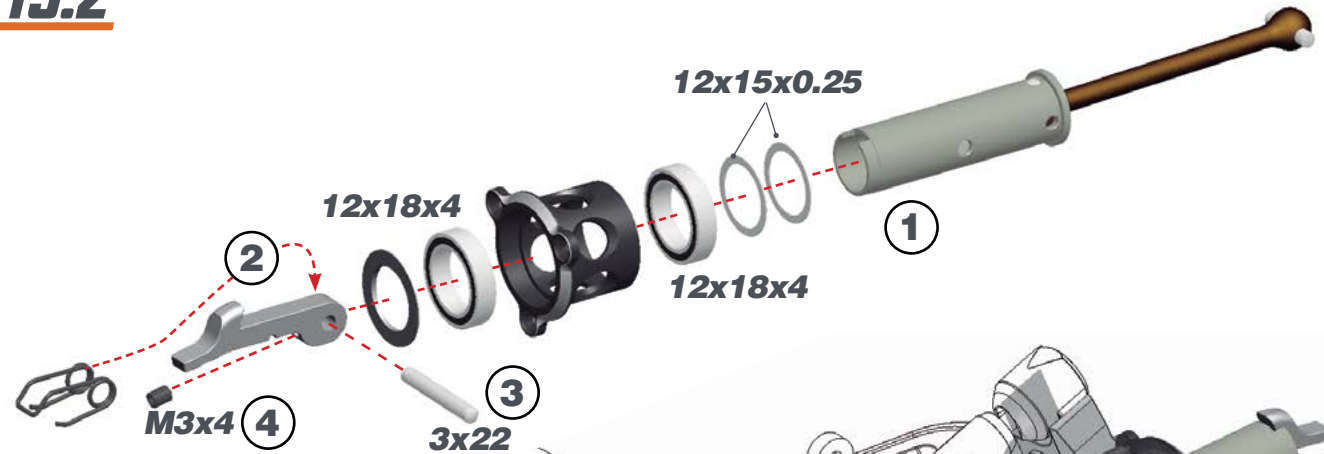

15.3

1- Note orientation of the outside wheel axle shim.  
 2- Note position of the lever spring.

M2.5x8

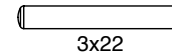
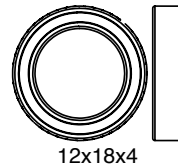
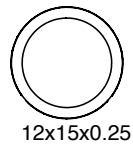
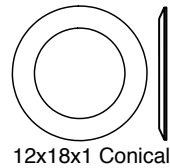
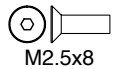
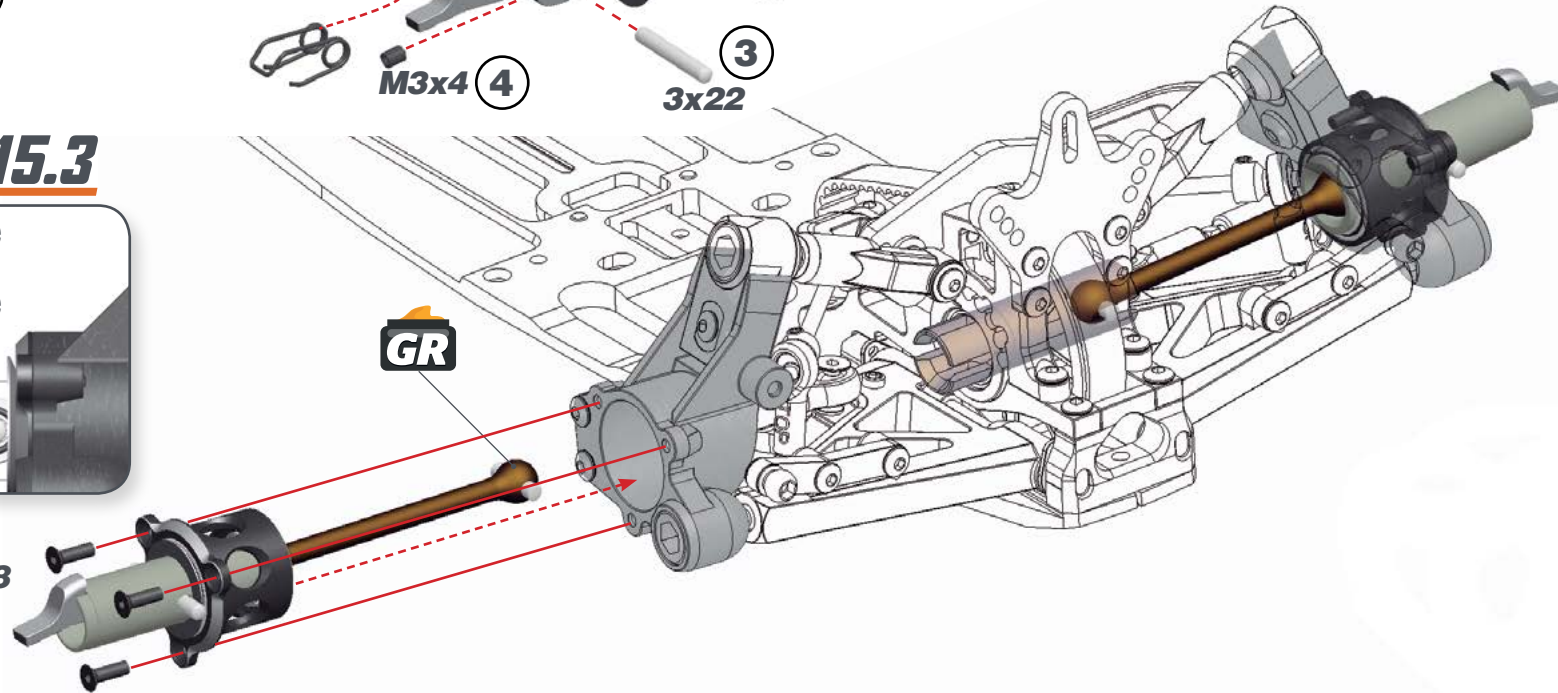



STEP 16 BAG 5

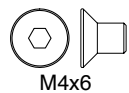
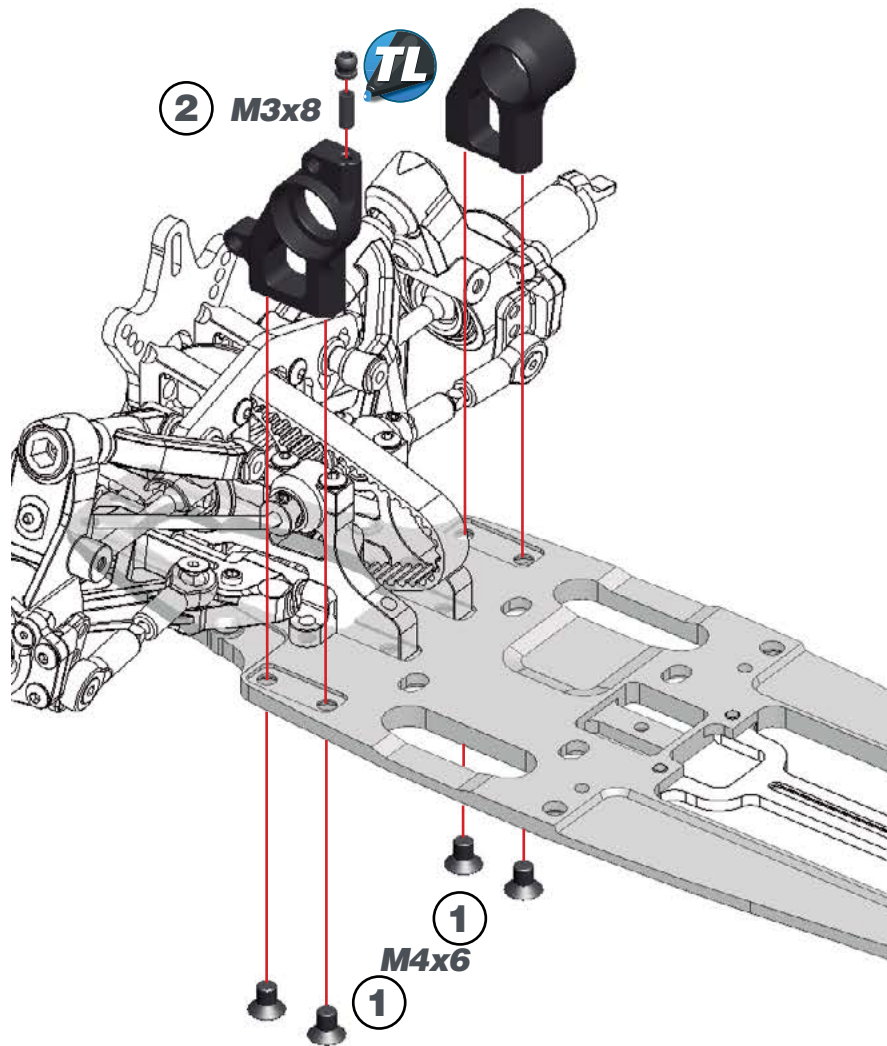

STEP 17

17.1

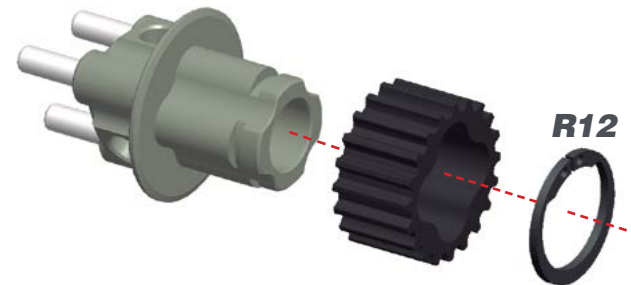

17.2

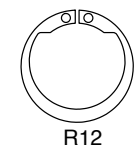
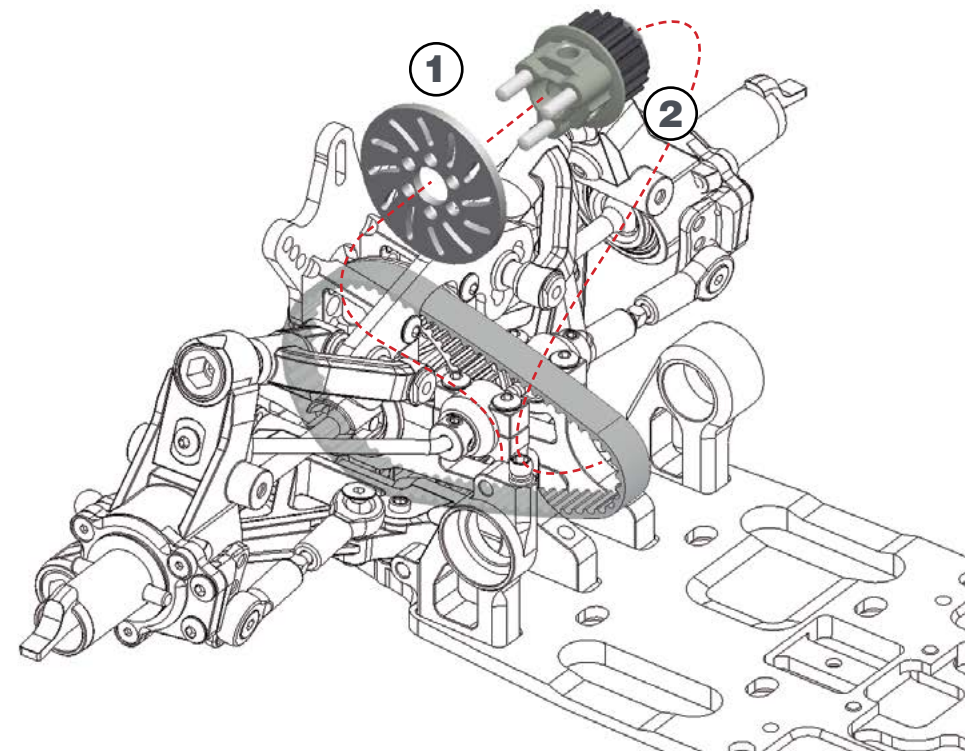

**STEP 18**

**18.1** M3x6



**18.2**

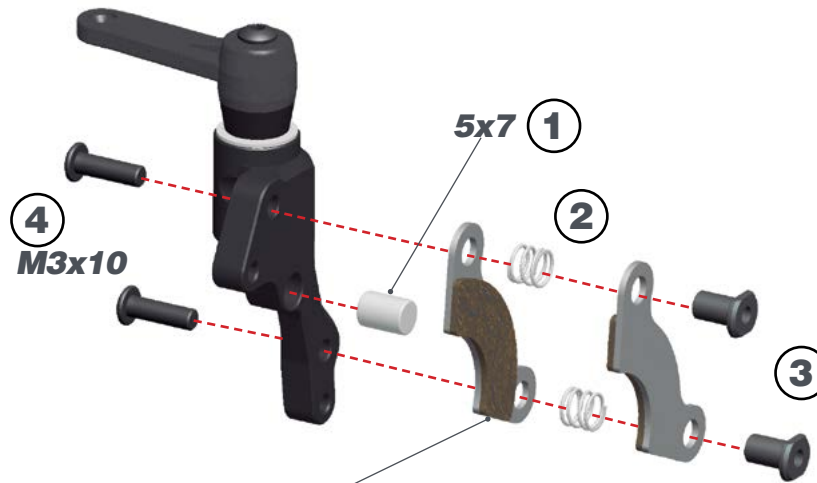

**!** After tightening the M3x10 screws check that the brake pads slide easy over the bushings.

**18.3**

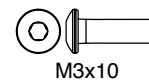
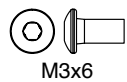
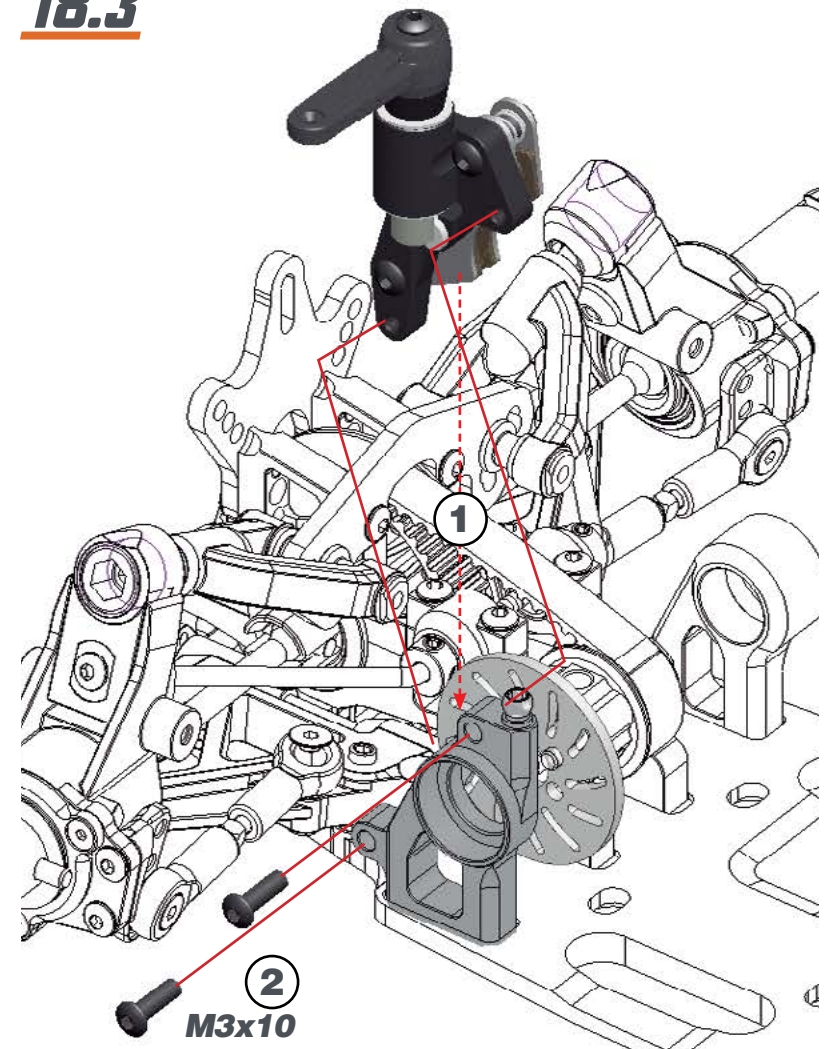

## STEP 19 BAG 6

### 19.1

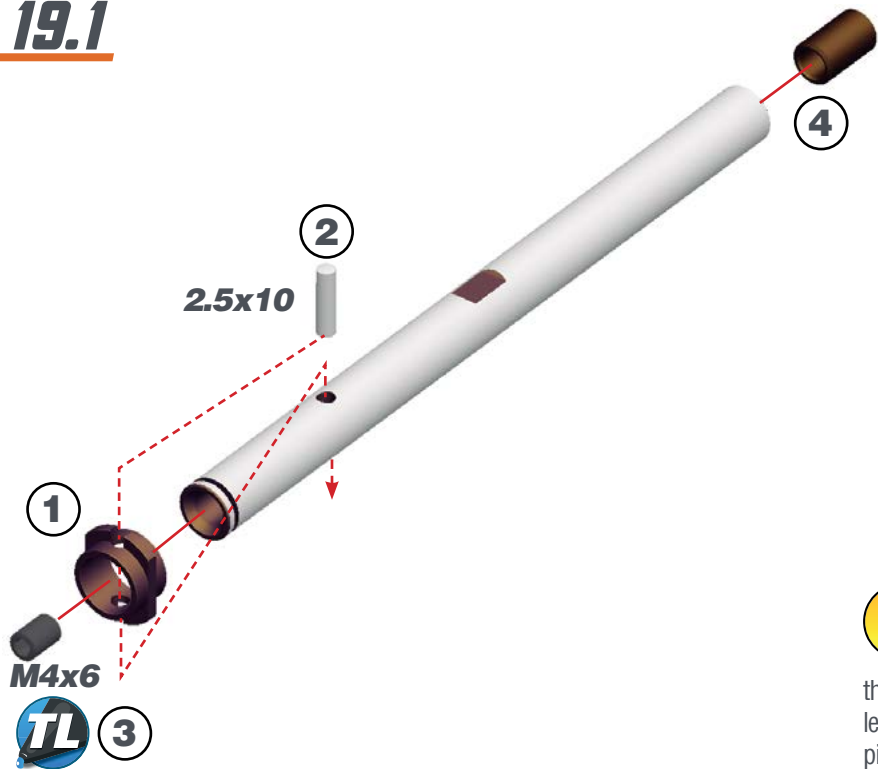

### 19.2

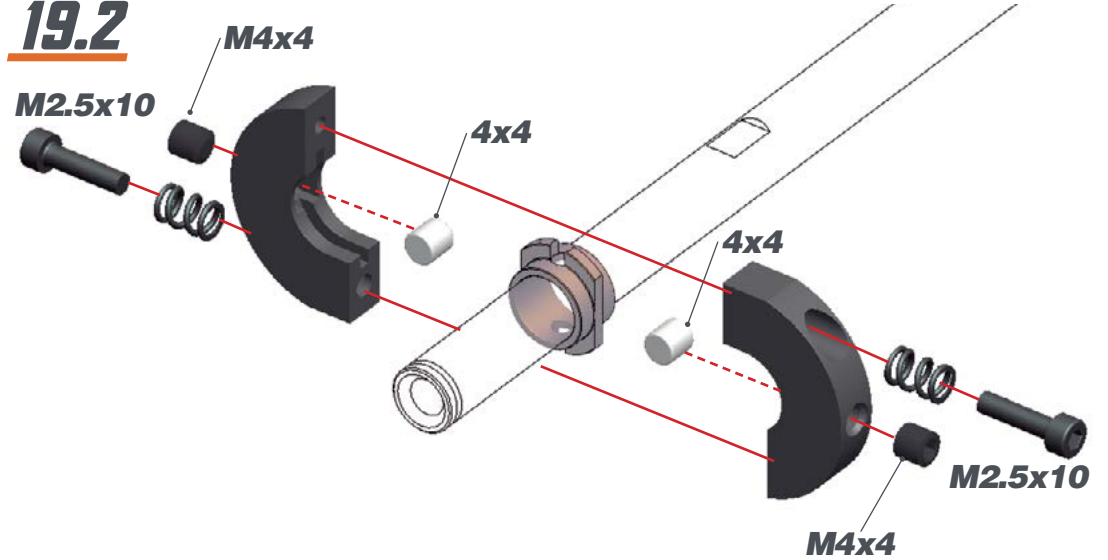

**!** 1- The M2.5x10 screws adjust the SHIFT POINT. As default adjustment screw them until the screws will be leveled with the hole as in the right pictures.

2- Adjust the M4x4 screw to minimise the gap between the shoes and the bell, but still spinning free without touching. Check after each run.

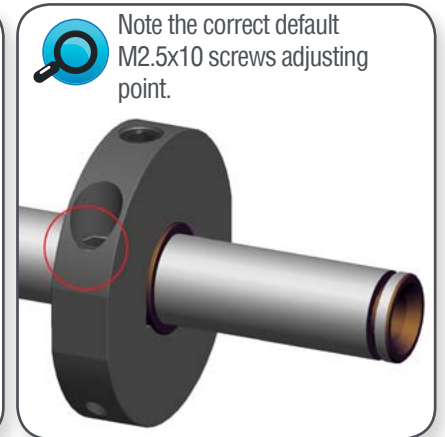
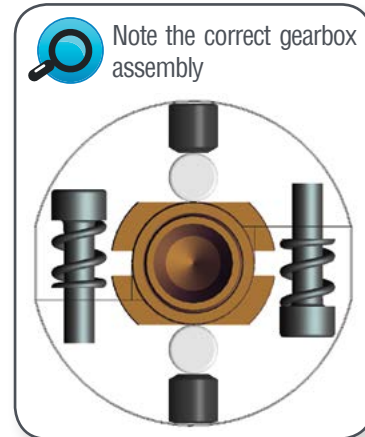



STEP 20

20.1

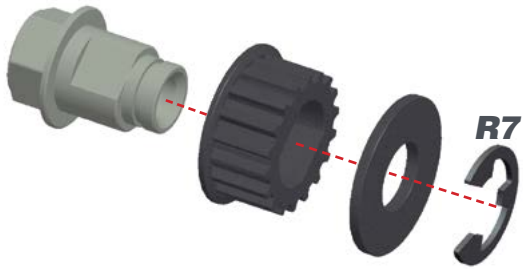

20.2

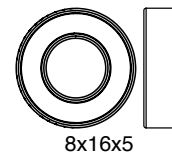
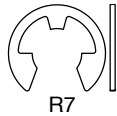
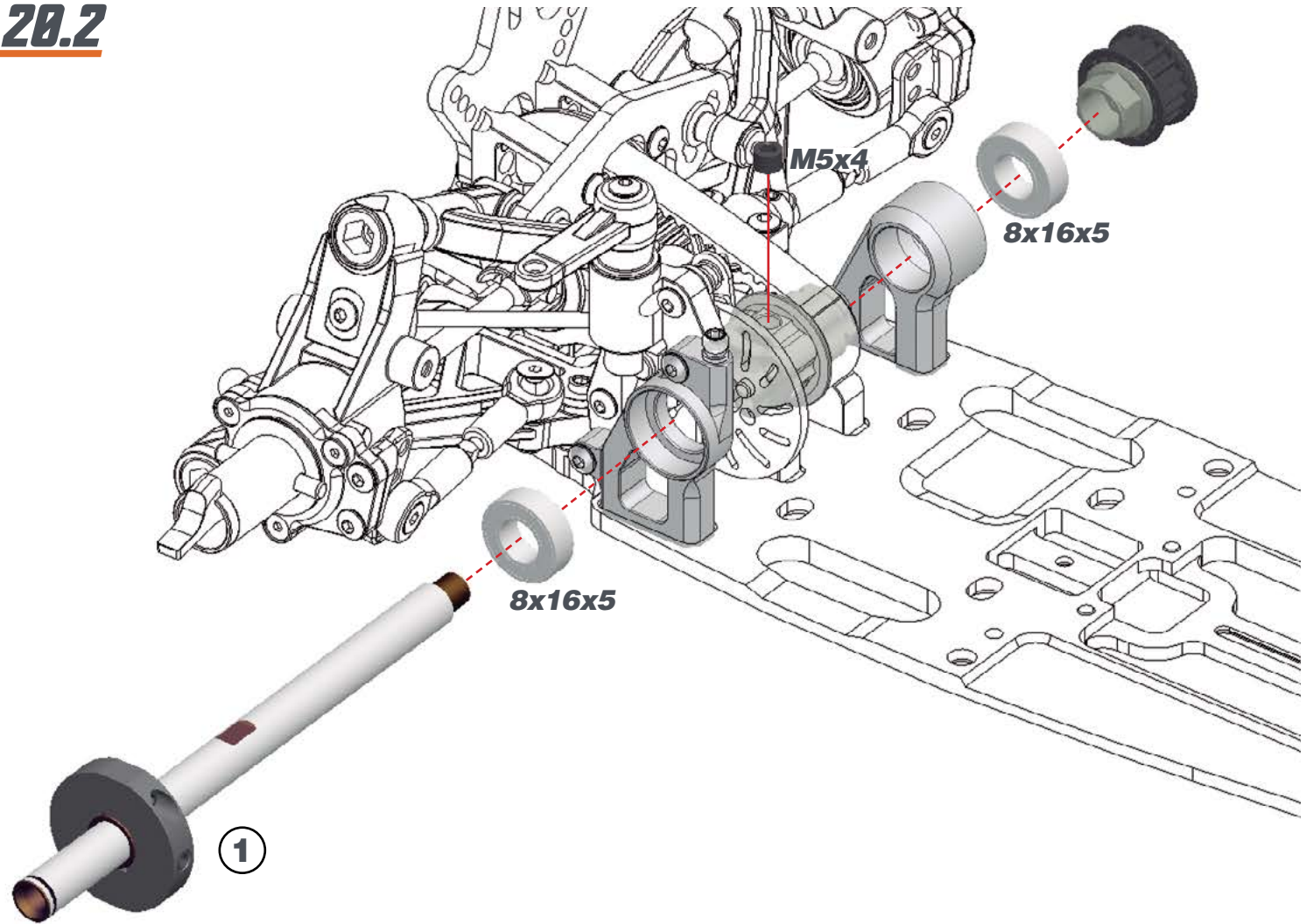

**STEP 21**

**21.1**

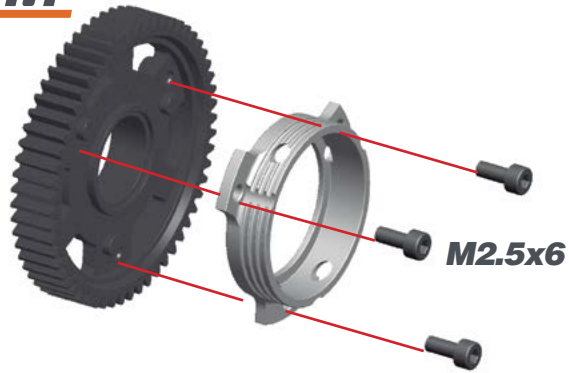

**21.2**

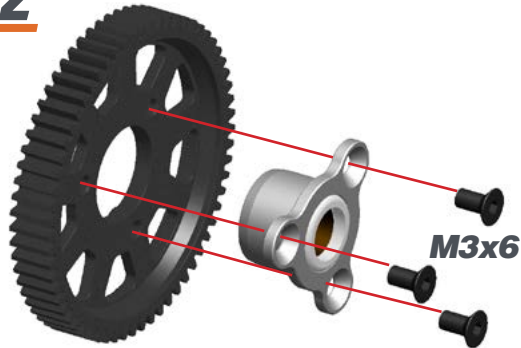

**21.3**

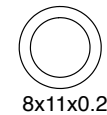
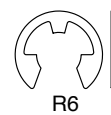
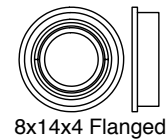
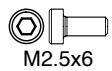
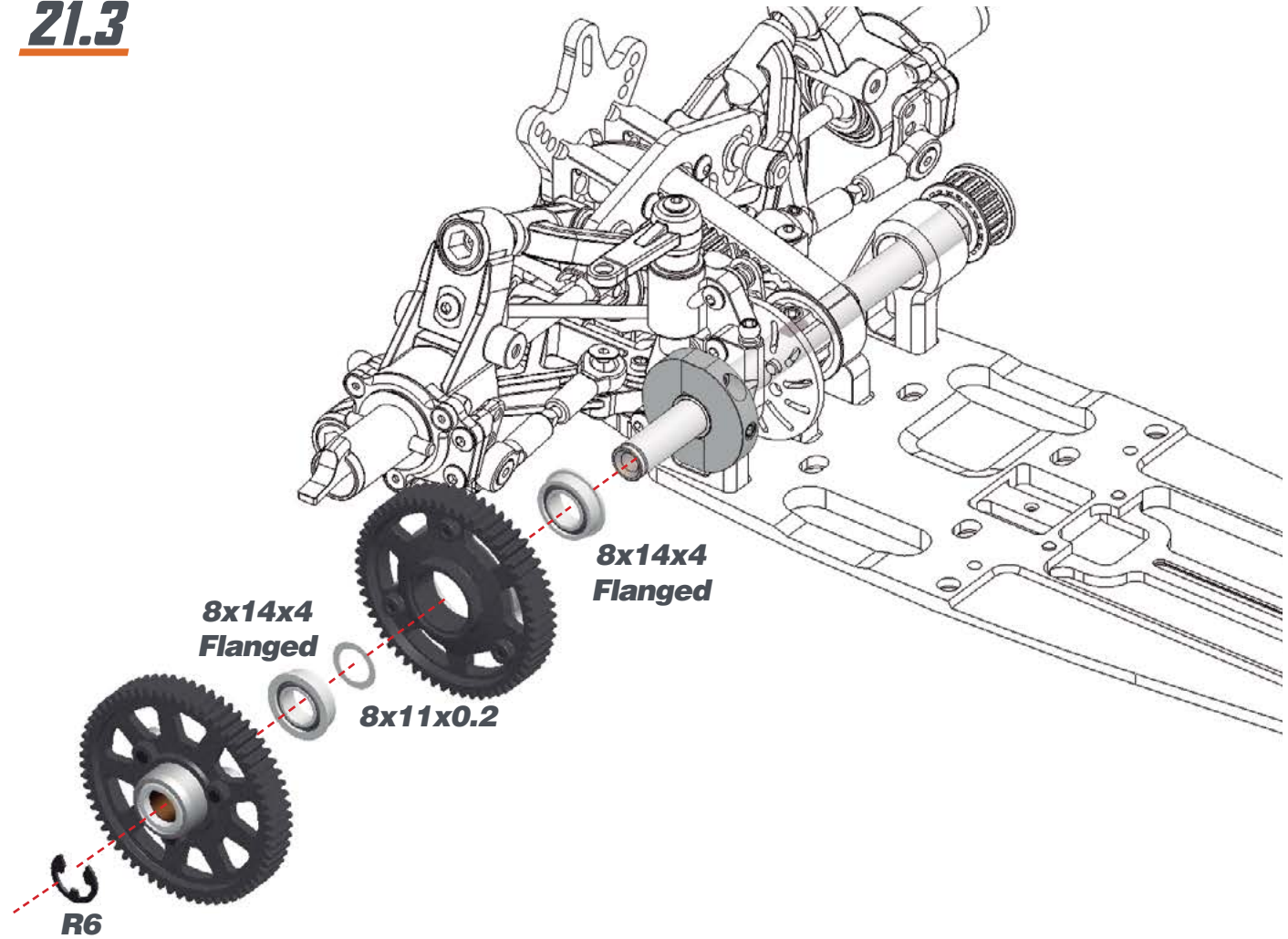

## STEP 22 BAG 7

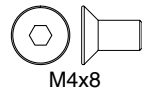
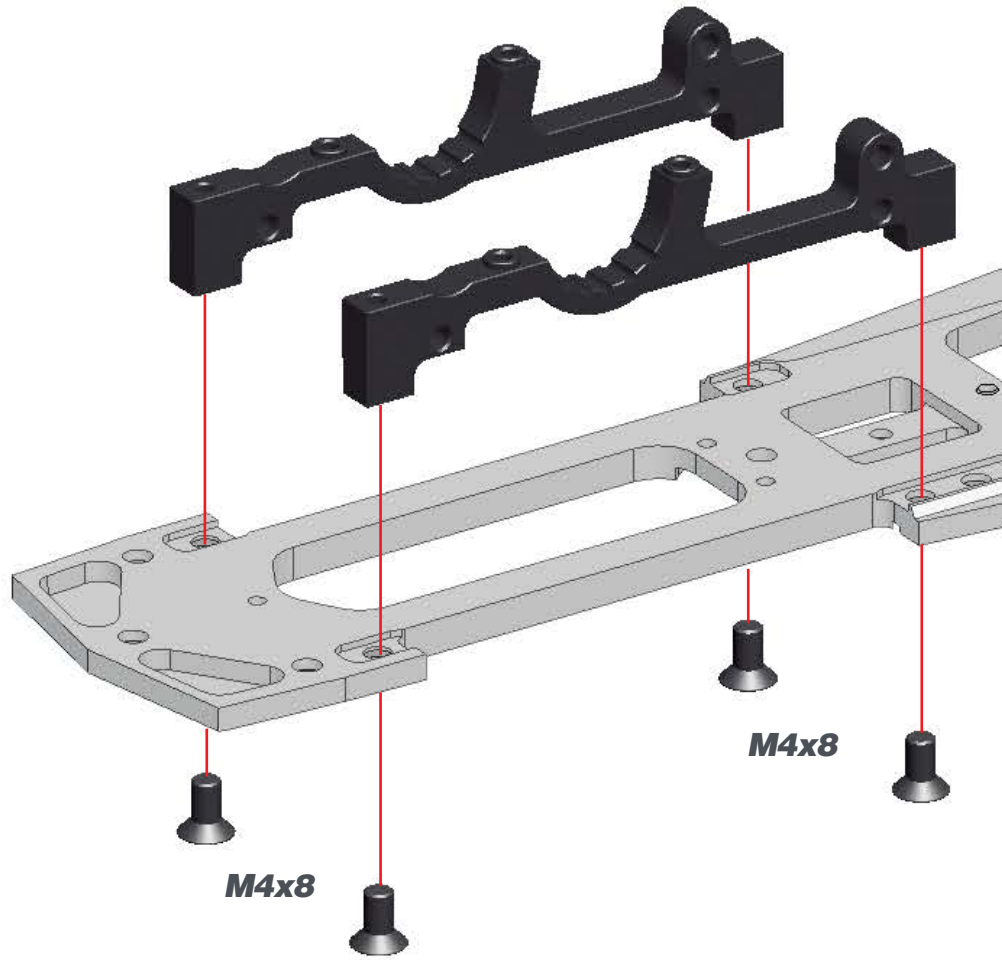

## STEP 23

### 23.1

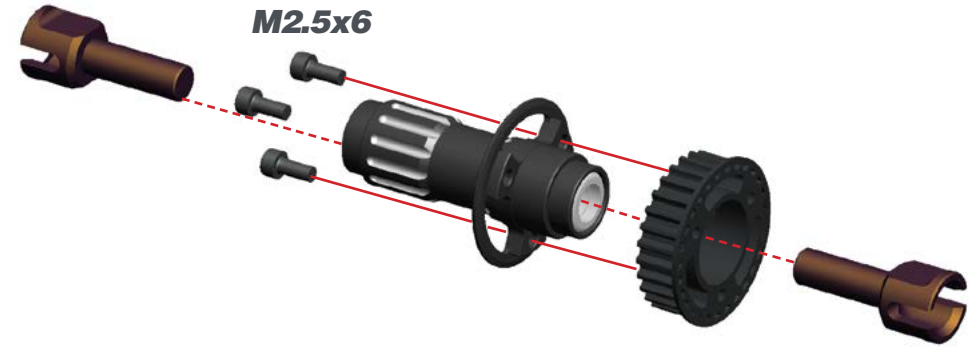

### 23.2

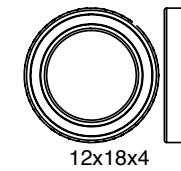
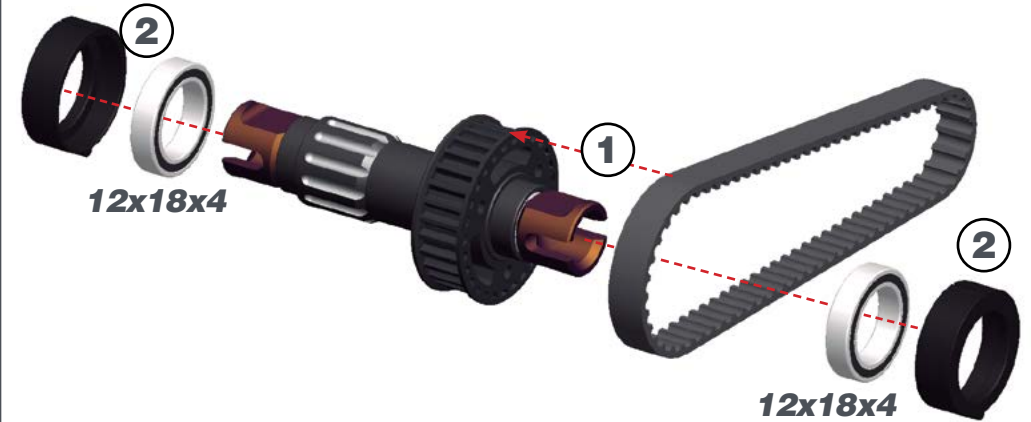



STEP 24

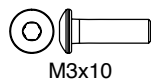
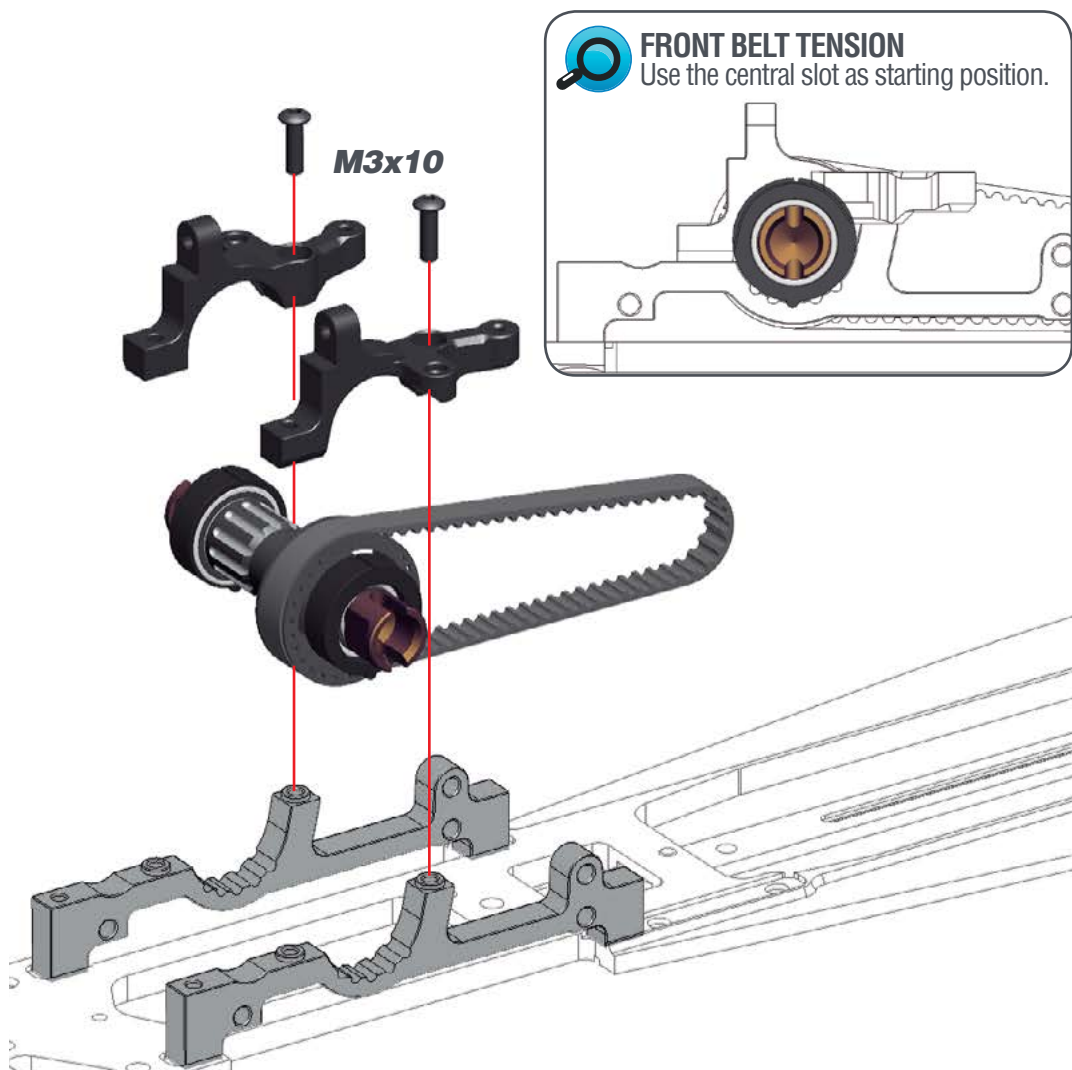

STEP 25

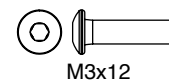
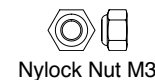
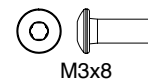
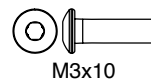
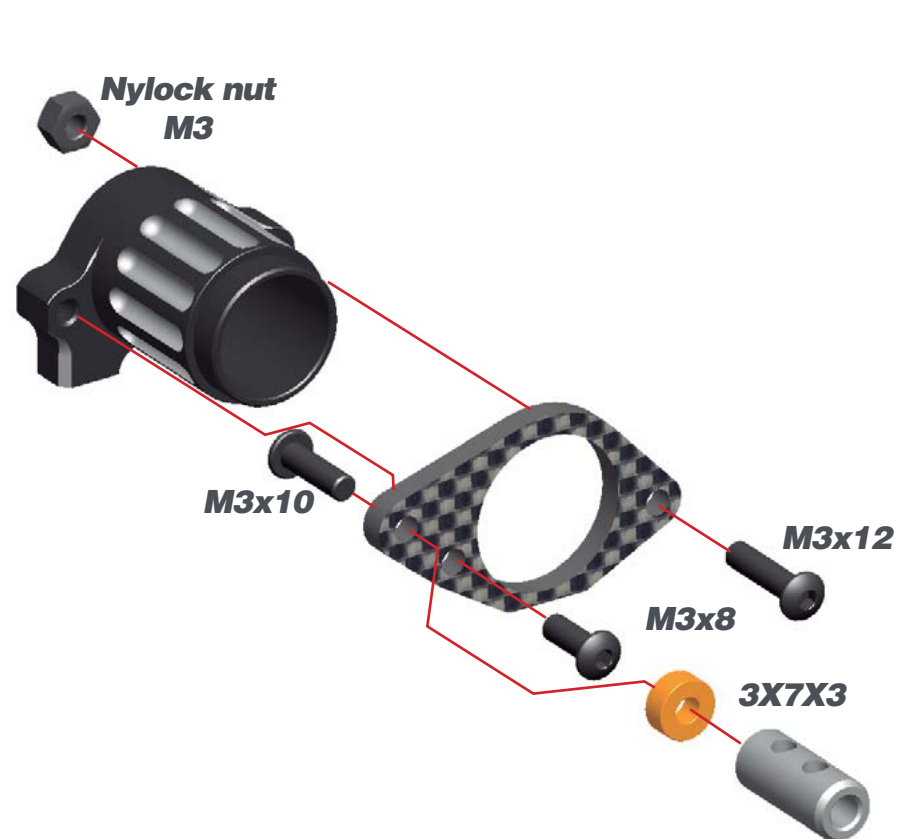

**STEP 26**

**26.1**

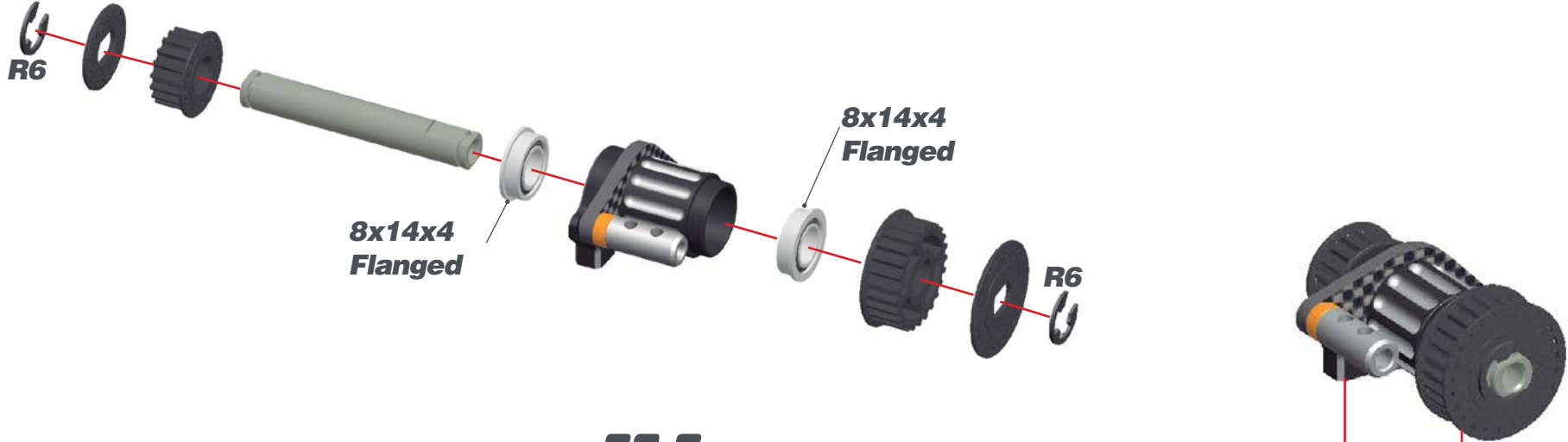

**26.2**

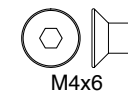
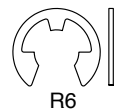
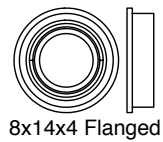
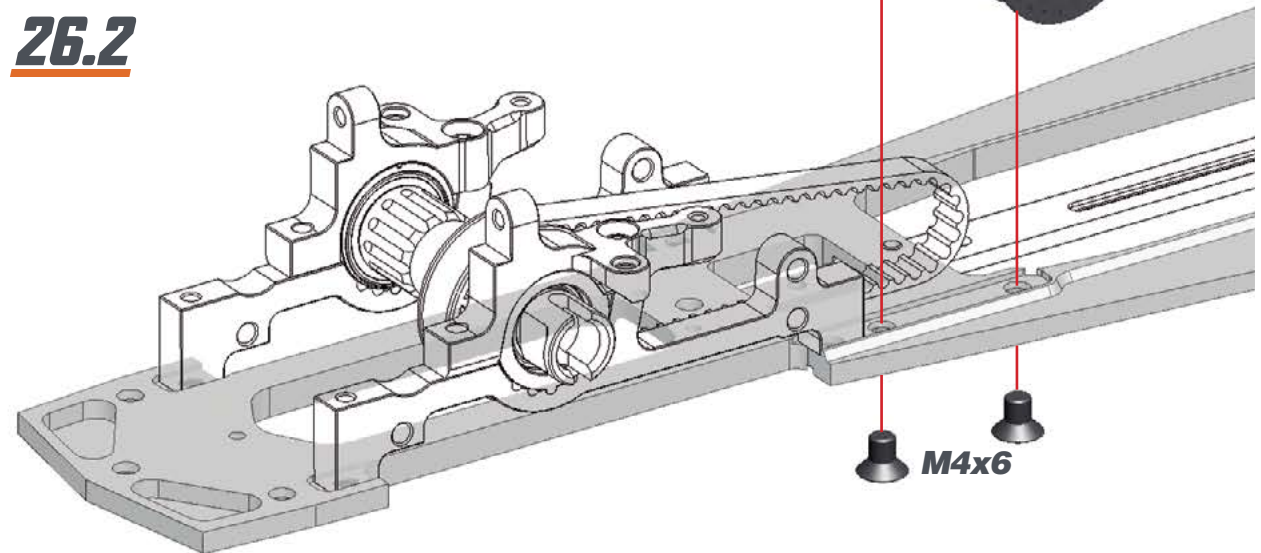

STEP 27 BAG 8

27.1 L=R

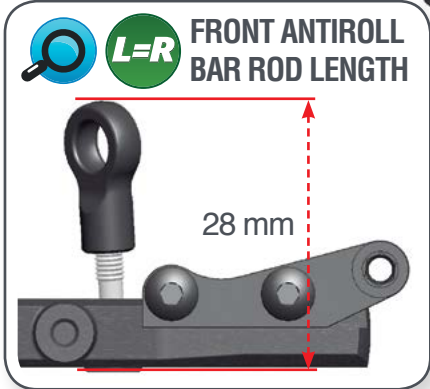

27.2

L=R FRONT LOWER SUSPENSION AND SHOCK BRACKETS

Serpent 990 allows to move front bottom arms 3 mm in (NARROW) and out (WIDE). To maintain the same shock angle, use the suspension bracket and shock bracket as shown here.

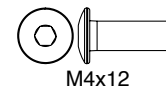
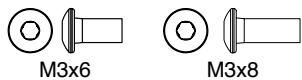
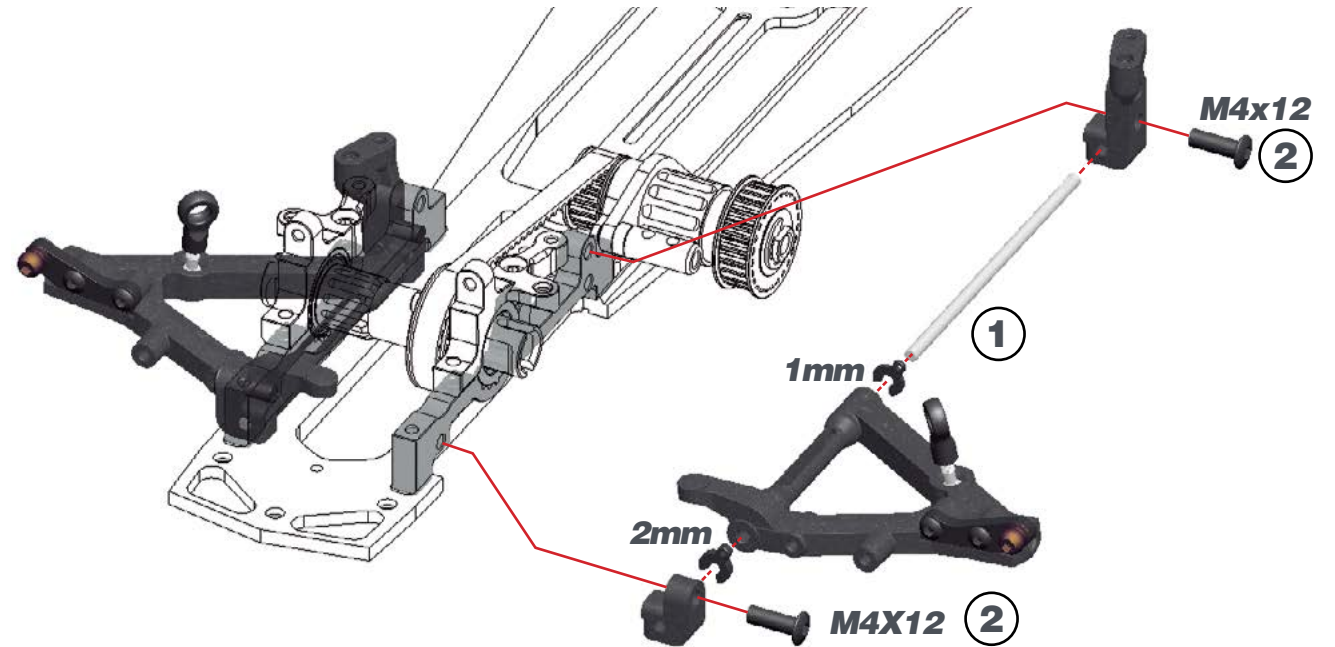
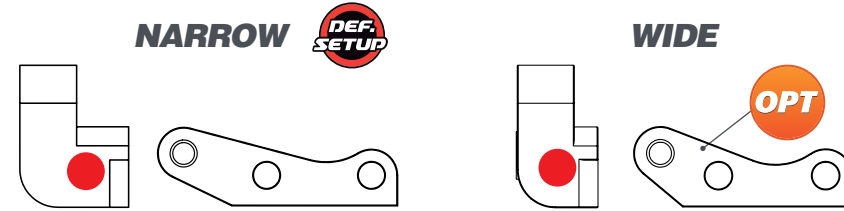



**STEP 28**

**28.1**



**FRONT DOWN STOPS**

**DEF. SETUP** **L=R**

1 mm

**28.2**

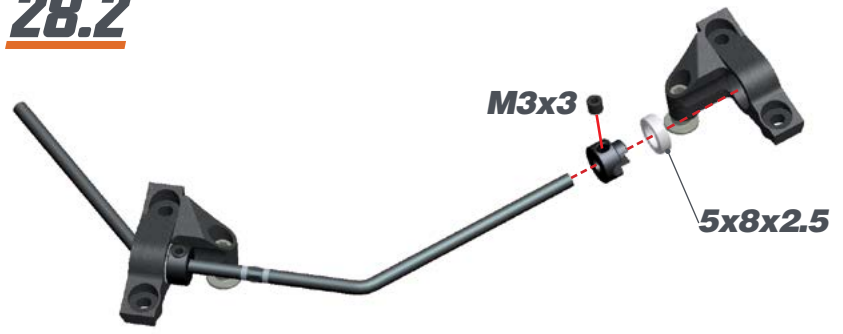

**28.3**

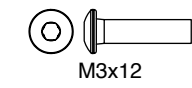
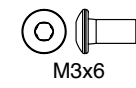
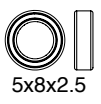
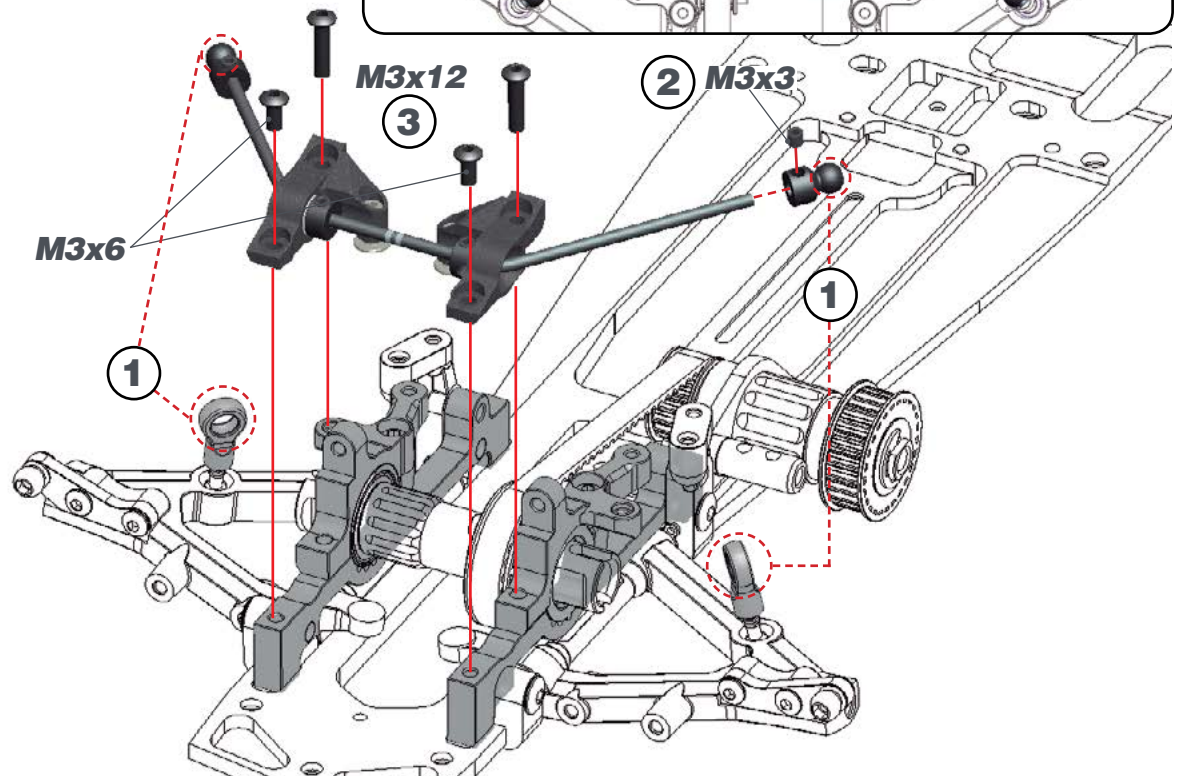
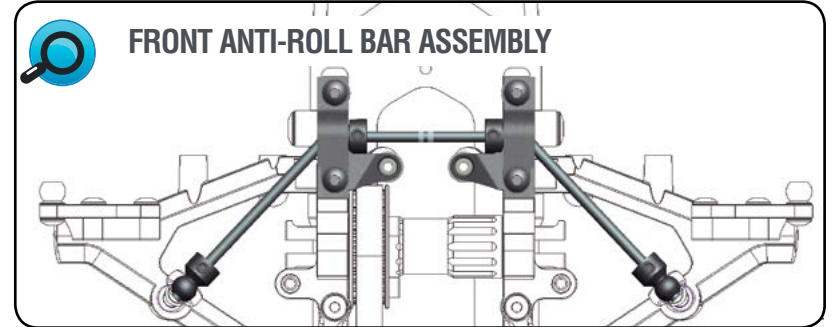

**STEP 29** BAG 9

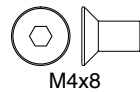
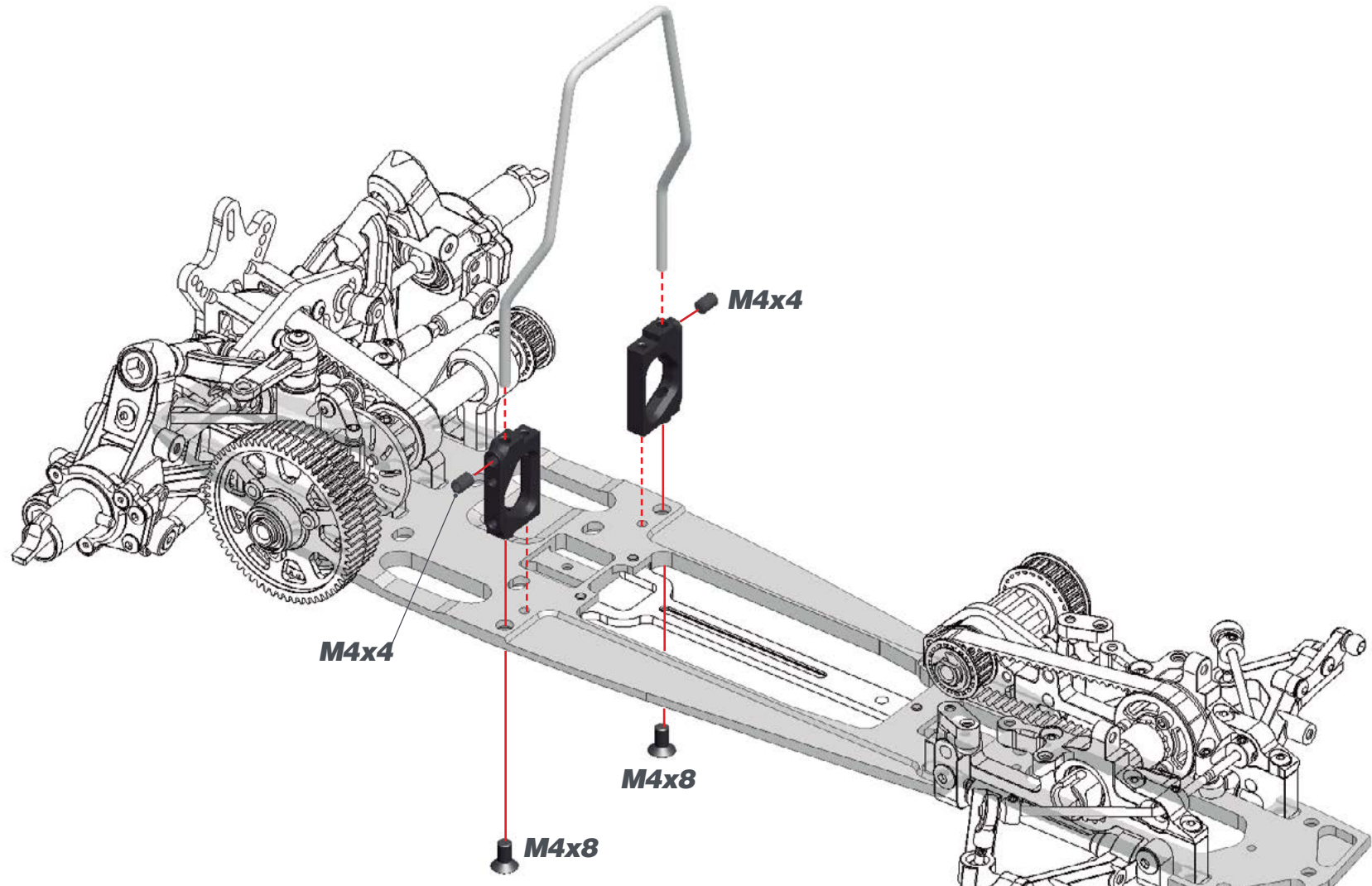

# STEP 30

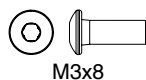
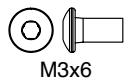
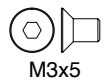
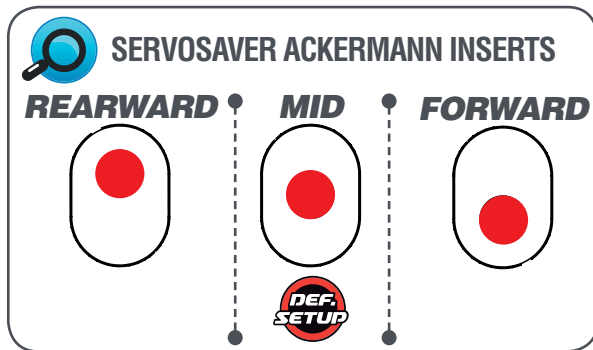
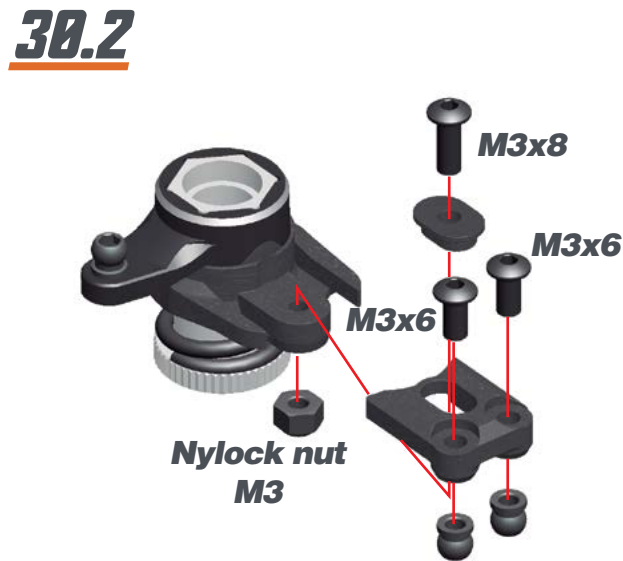

# STEP 31

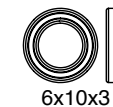
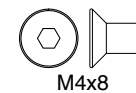
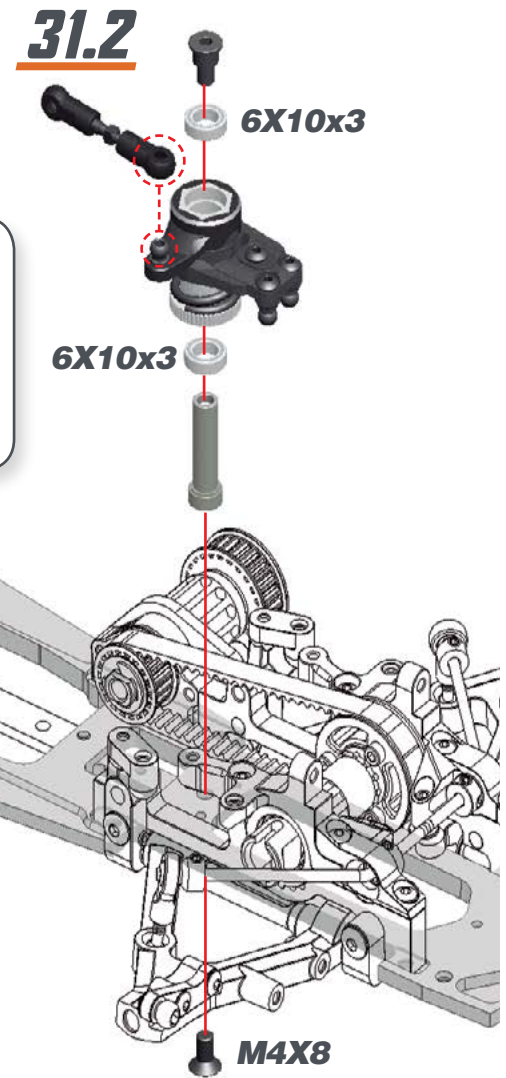



## STEP 32 BAG 10

## STEP 33

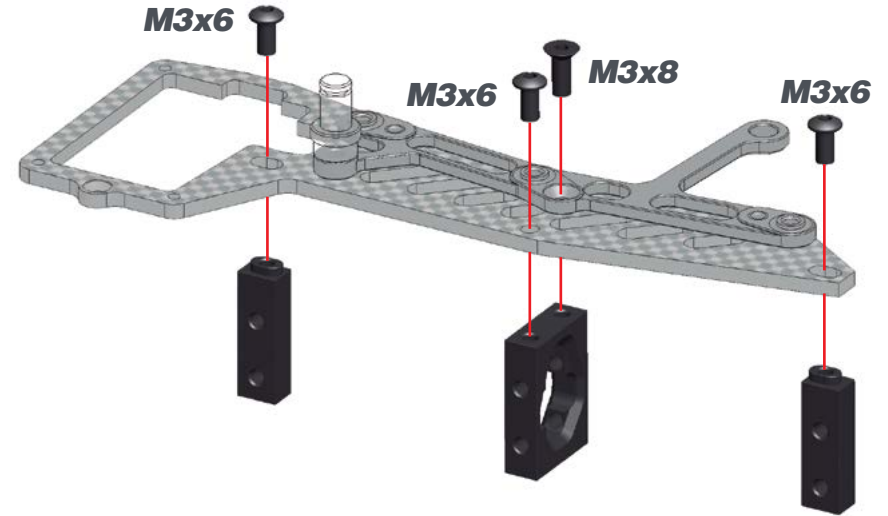
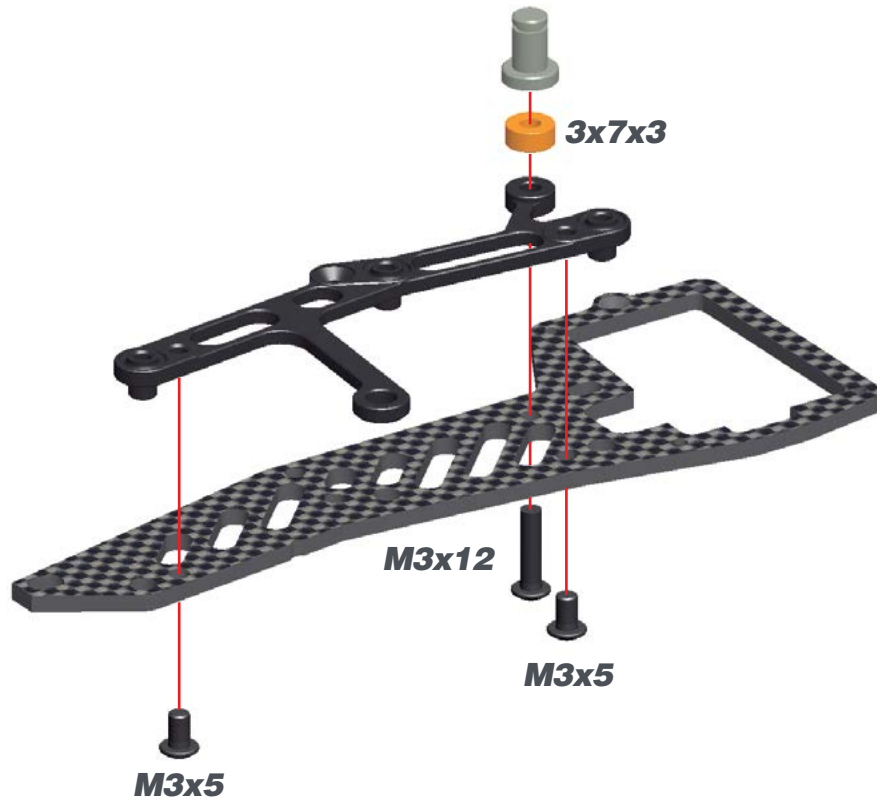

### RADIO BOX ASSEMBLY

The small servo mountings have a fixing protrusion which is excentric. Therefore it is possible to assemble them in two different ways in order to adapt the servo mountings to the different servo brands.

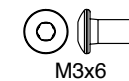
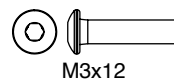
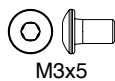
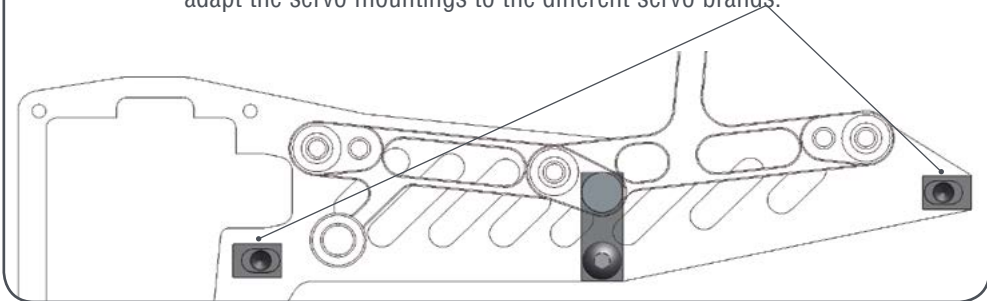

STEP 34

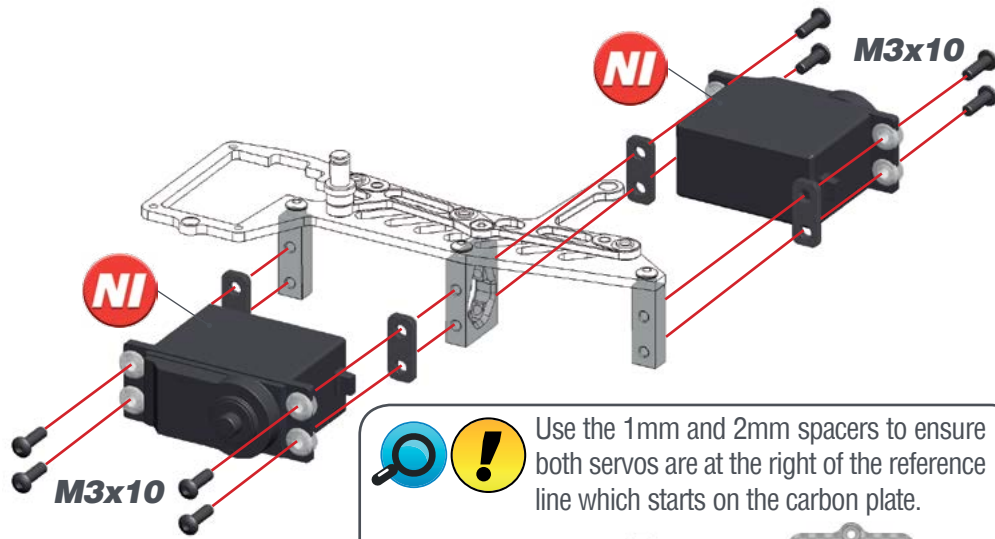

Use the 1mm and 2mm spacers to ensure both servos are at the right of the reference line which starts on the carbon plate.

Note the servo's wire diagram

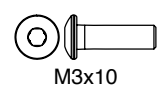

STEP 35

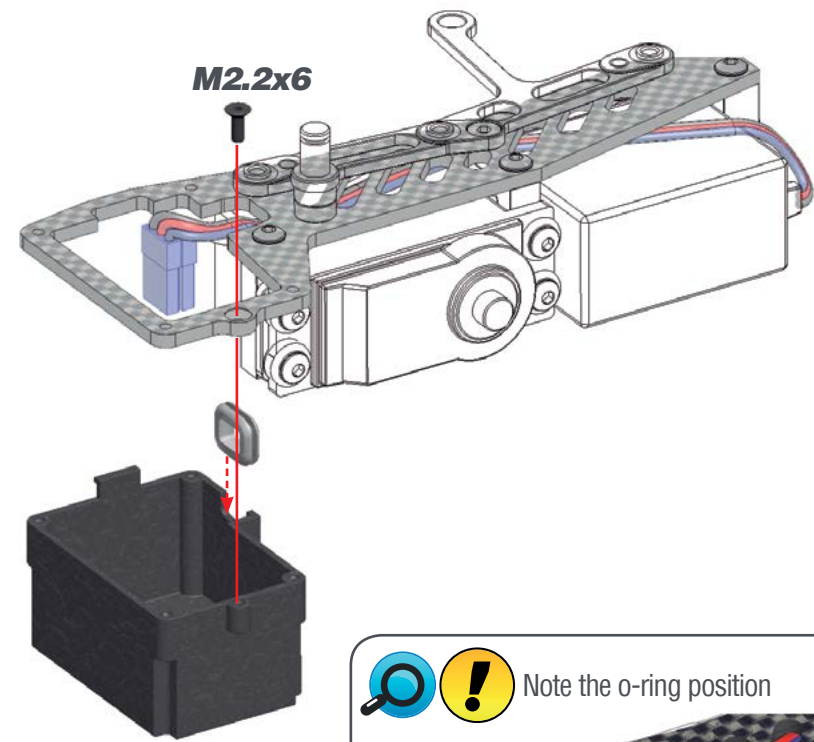

Note the o-ring position

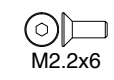





## STEP 38

**!** Check how many teeth your servo spline has (23, 24 or 25) and use the right lever.

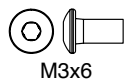
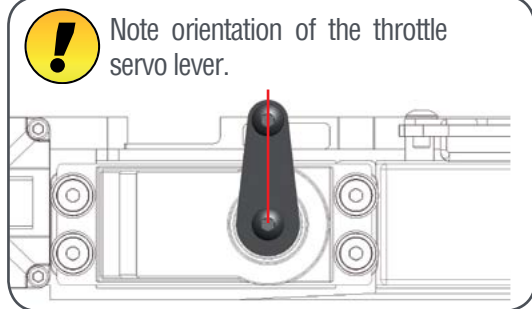
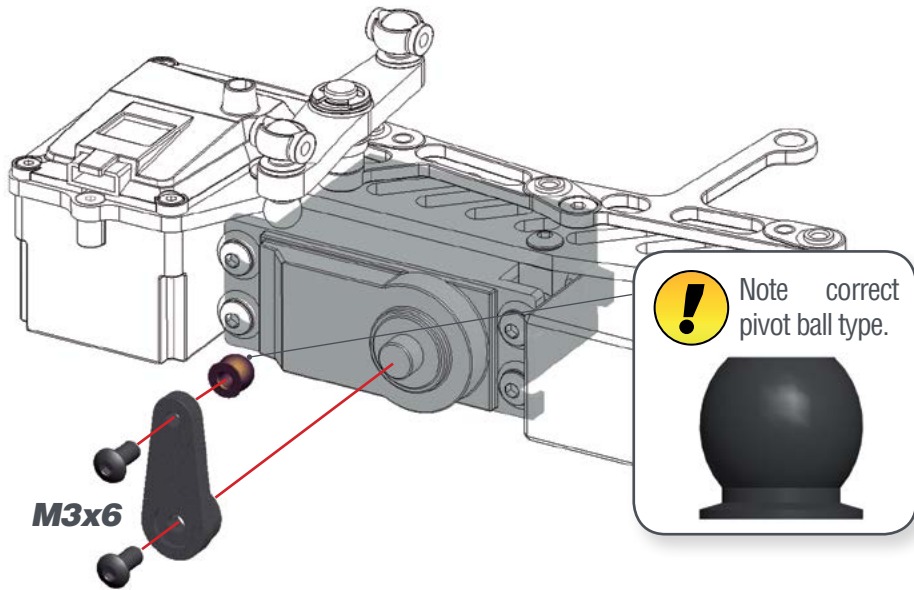

## STEP 39

### 39.1

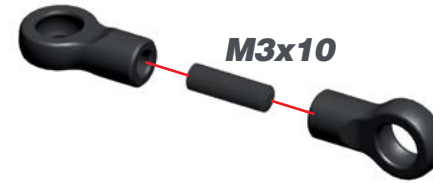

### 39.2

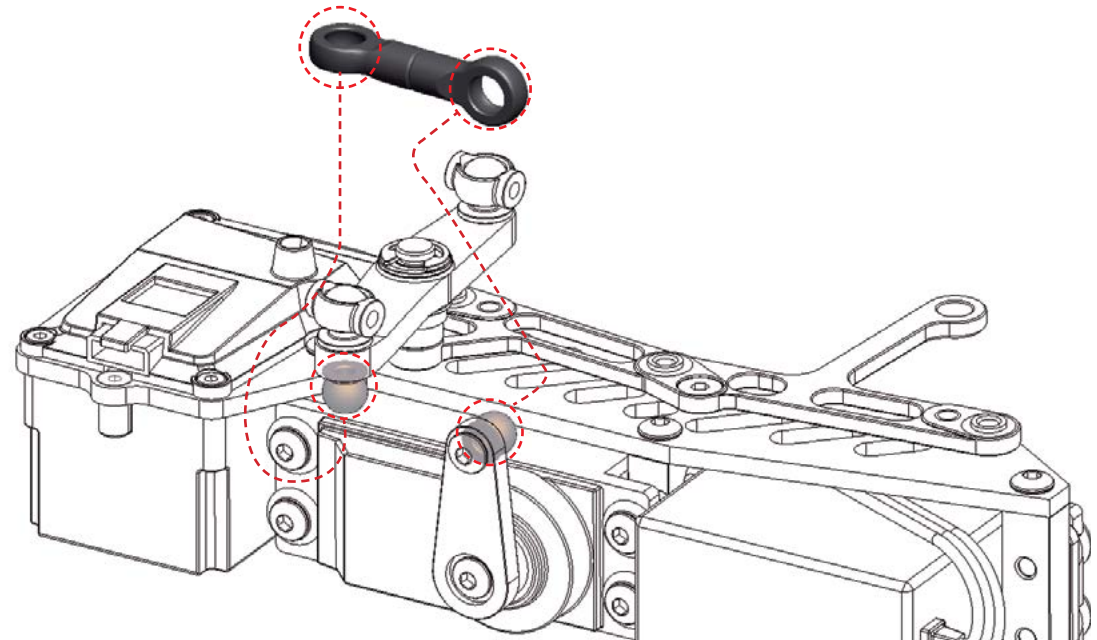

# STEP 40

**!** Check how many teeth your servo spline has (23, 24 or 25) and use the right lever.

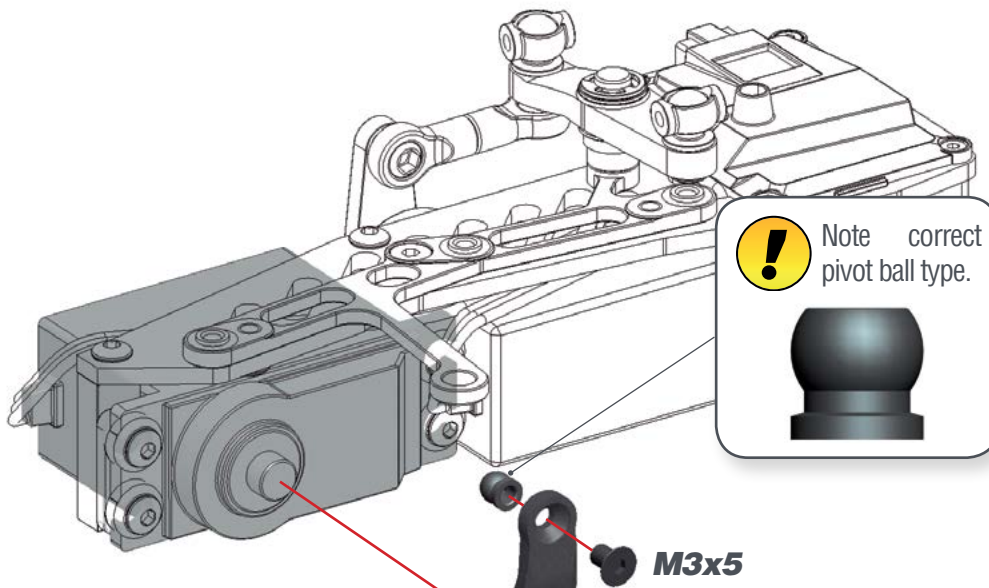

**!** Note correct pivot ball type.



M3x5

M3x8

**!** Note orientation of the steering servo lever.

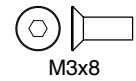

# STEP 41

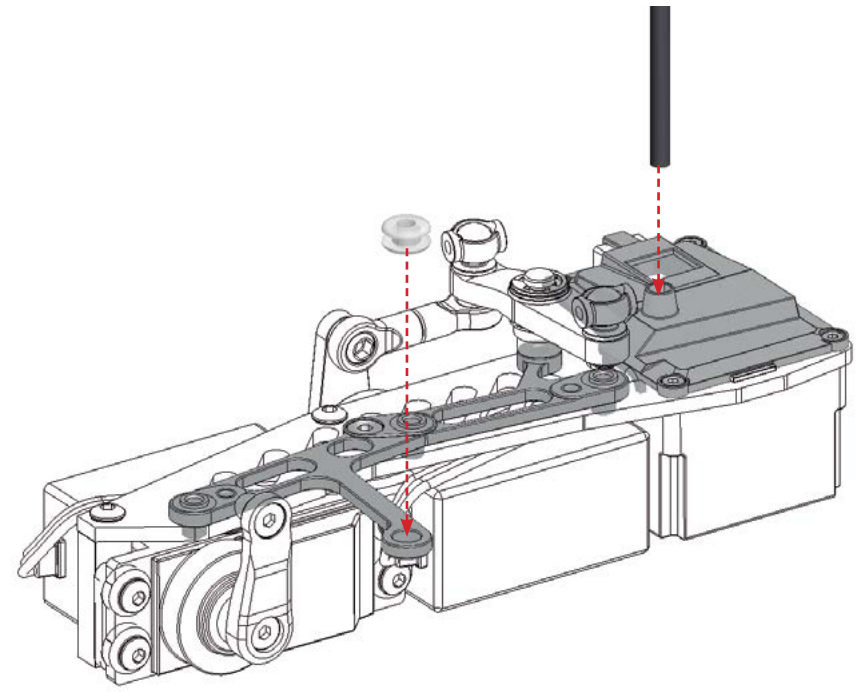

**!** Note the correct position of the grommet.

**STEP 42** **BAG 11**

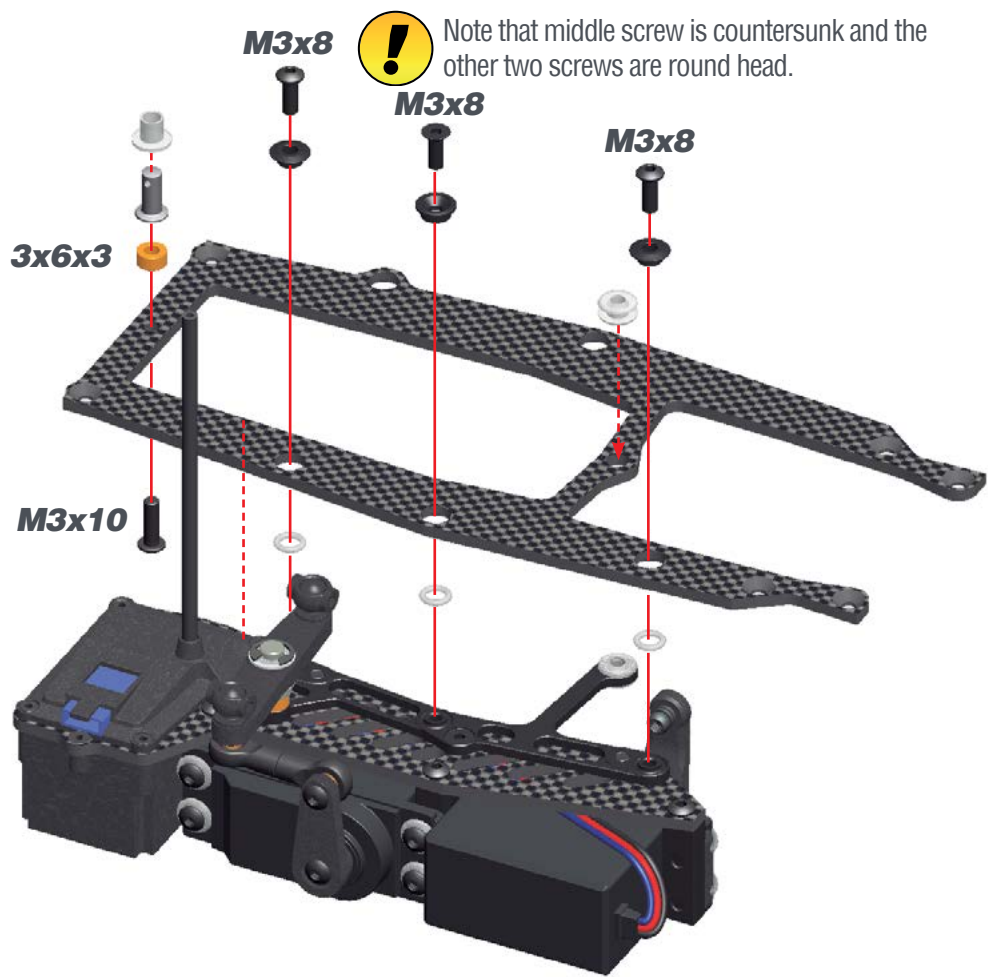

**!** Note that middle screw is countersunk and the other two screws are round head.

**STEP 43**

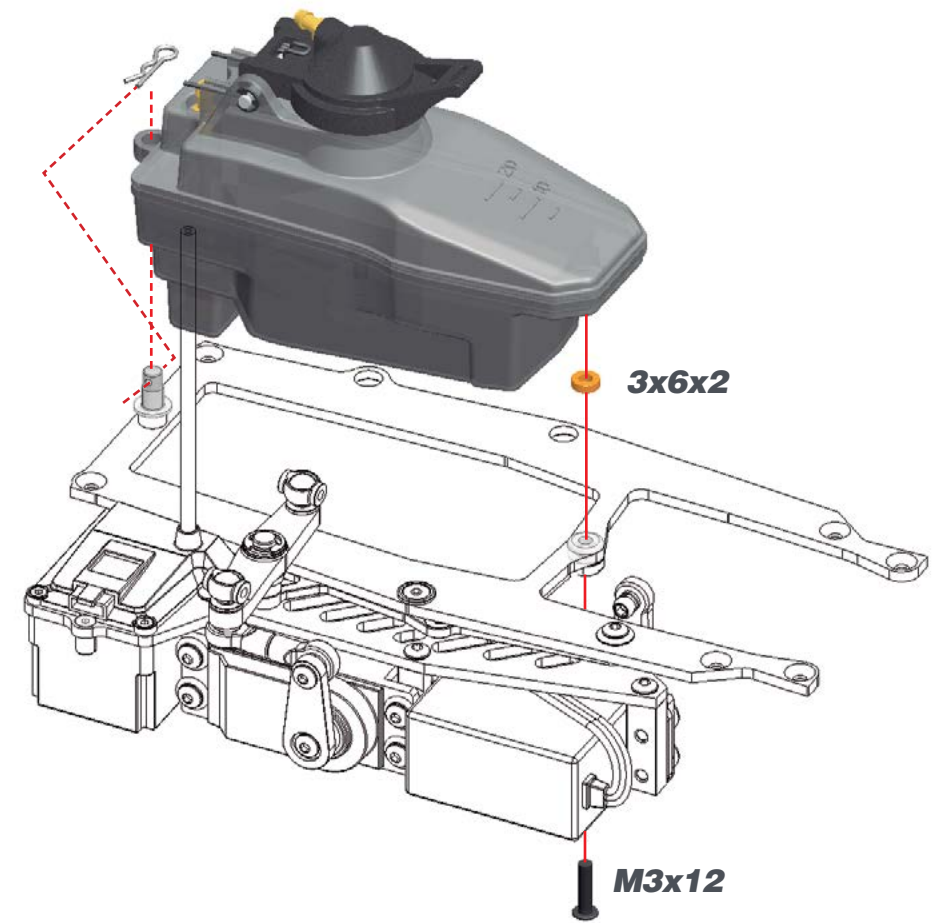



# STEP 44

## 44.1



**!** Use tape to mount the battery to the plastic support.

## 44.2

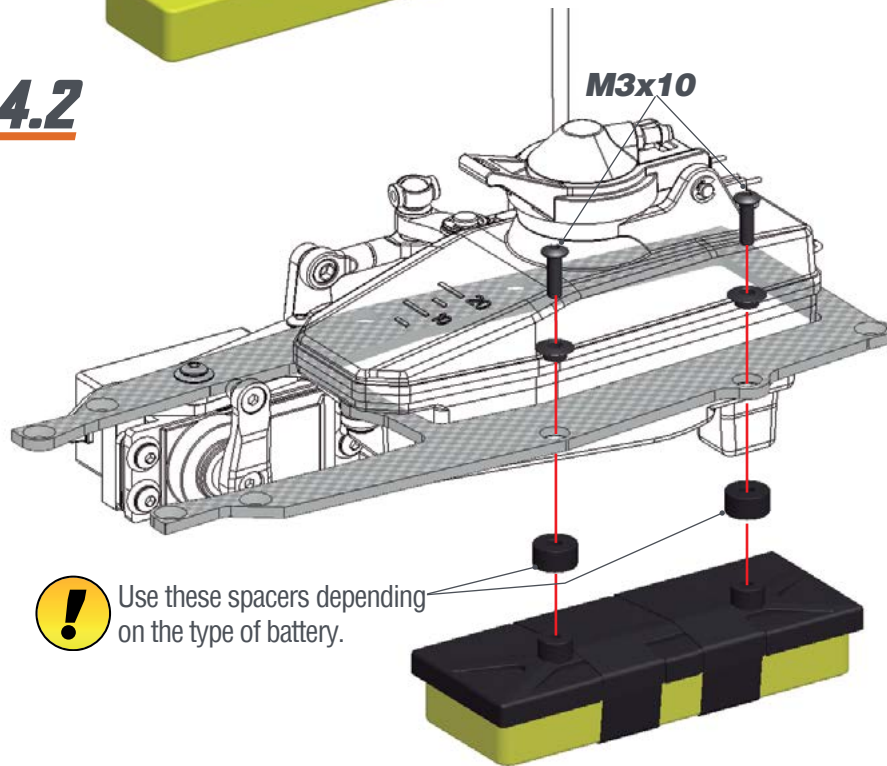

**!** Use these spacers depending on the type of battery.

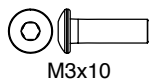

# STEP 45

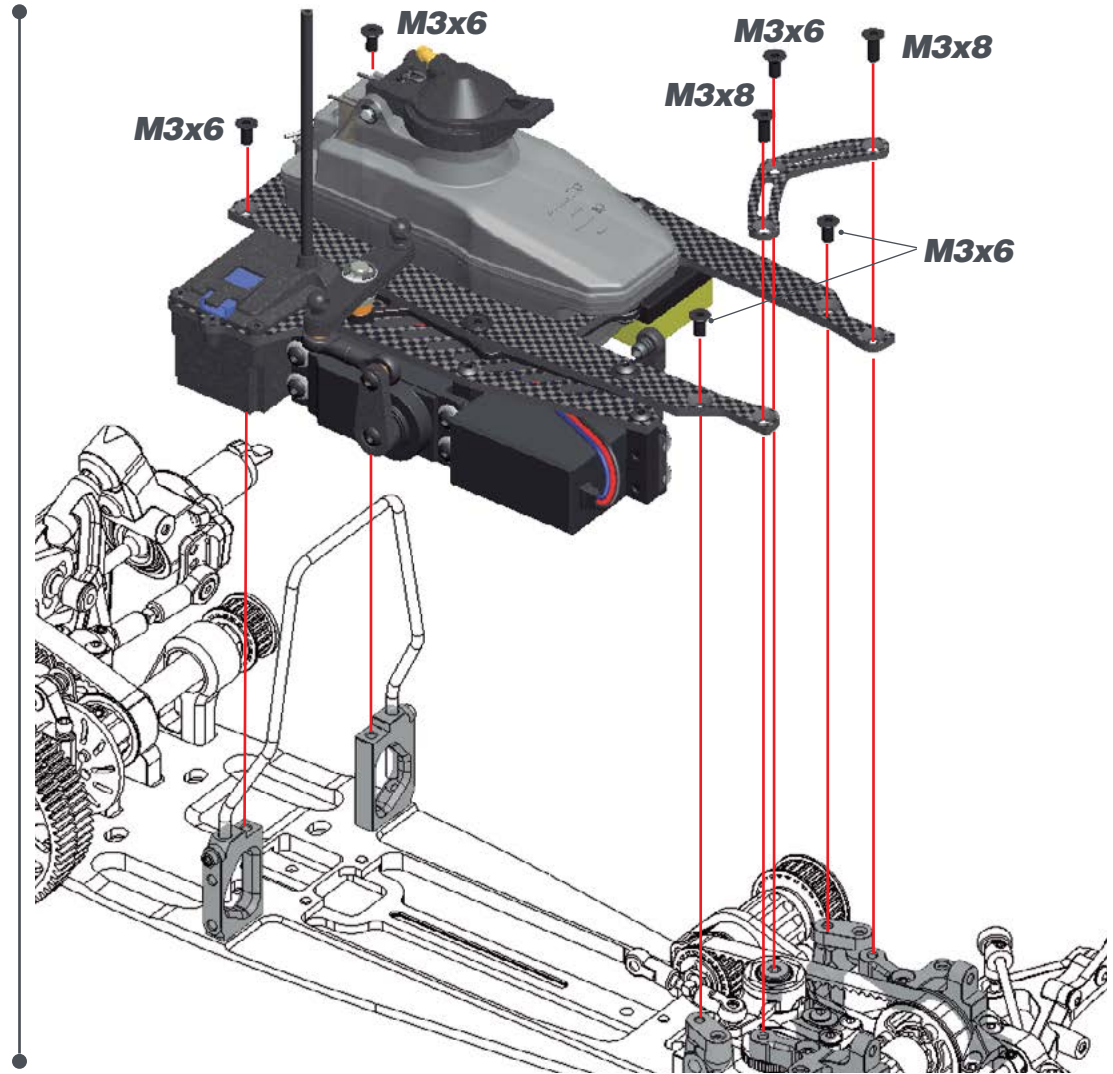

## STEP 46 BAG 12

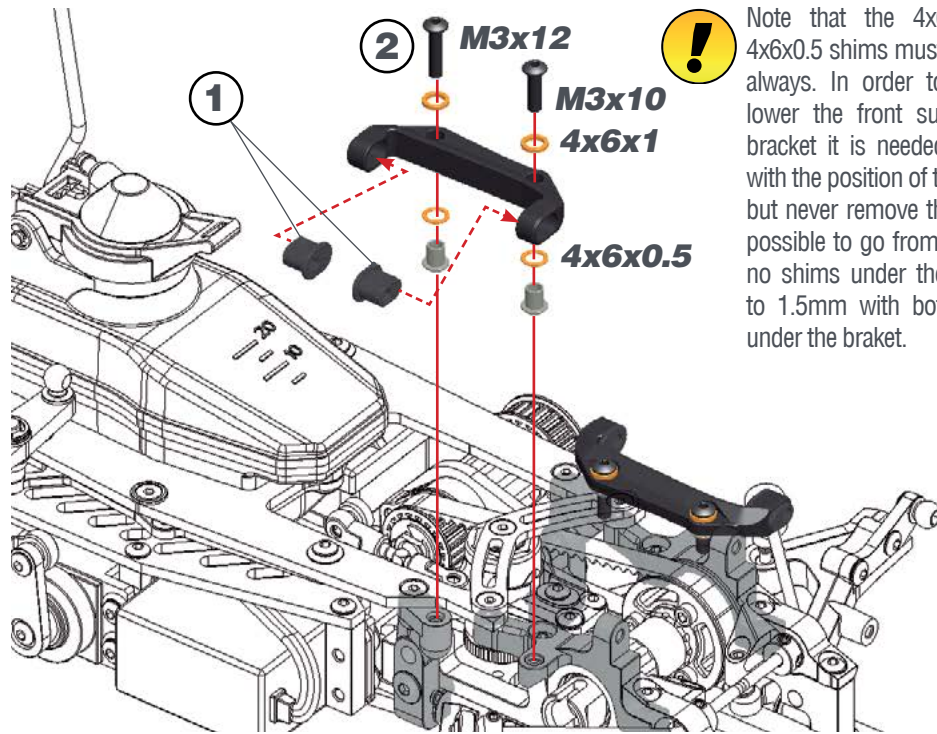

Note that the 4x6x1 and 4x6x0.5 shims must be used always. In order to rise or lower the front suspension bracket it is needed to play with the position of the shims but never remove them. Is it possible to go from "0" with no shims under the bracket to 1.5mm with both shims under the bracket.

**L=R FRONT SUSPENSION INSERTS CHART**

INSIDE		MID		OUTSIDE	
RIGHT	LEFT	RIGHT	LEFT	RIGHT	LEFT

**DEF. SETUP**

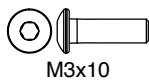
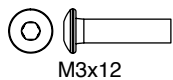

## STEP 47

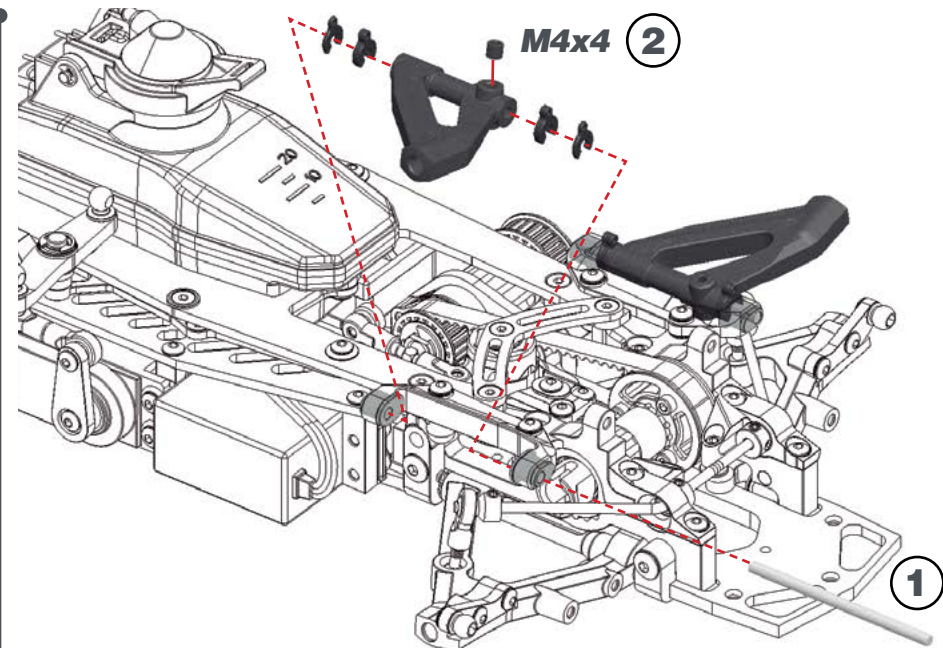

**L=R FRONT CASTER DEFAULT SPACERS**

**DEF. SETUP**

1mm 2mm 2mm 1mm



# STEP 48

L=R

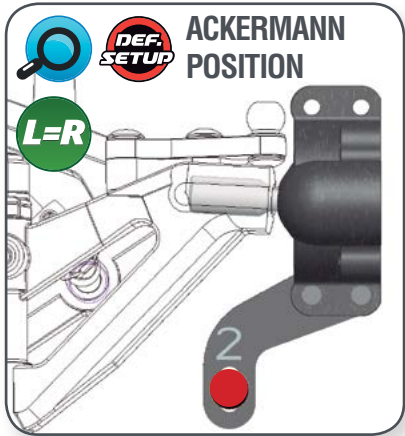
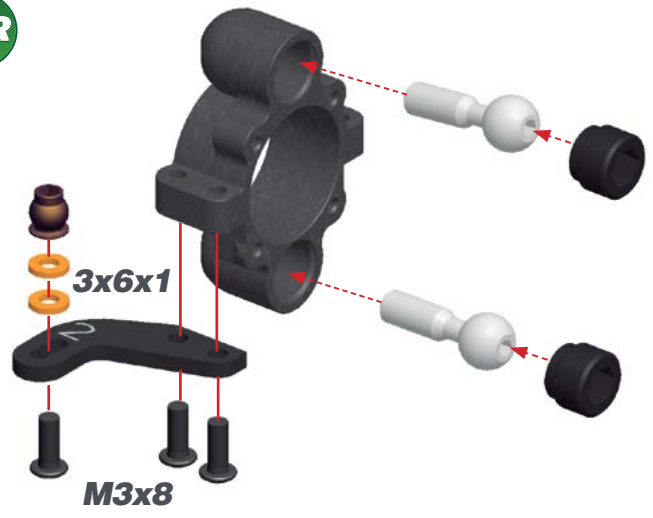

# STEP 49

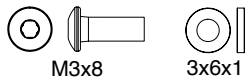
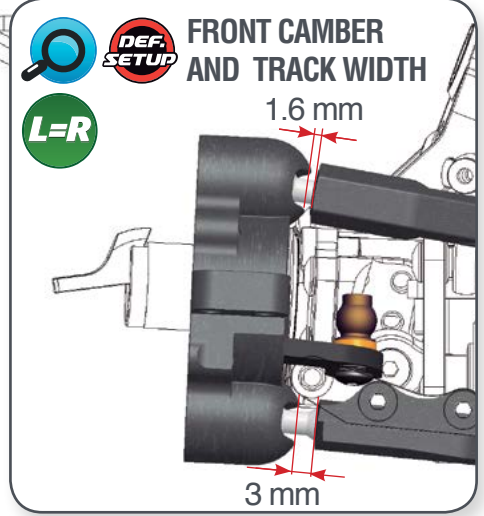
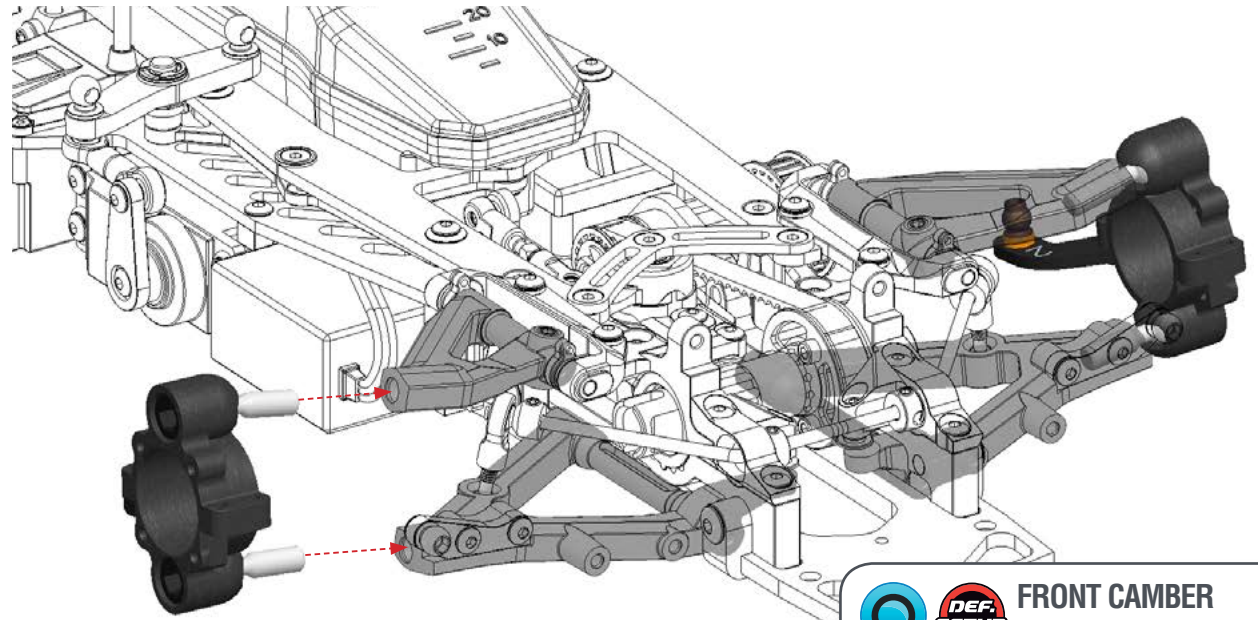



**STEP 50**

**50.1**



STEERING TRACKROD LENGTH

41.5 mm



**50.2**

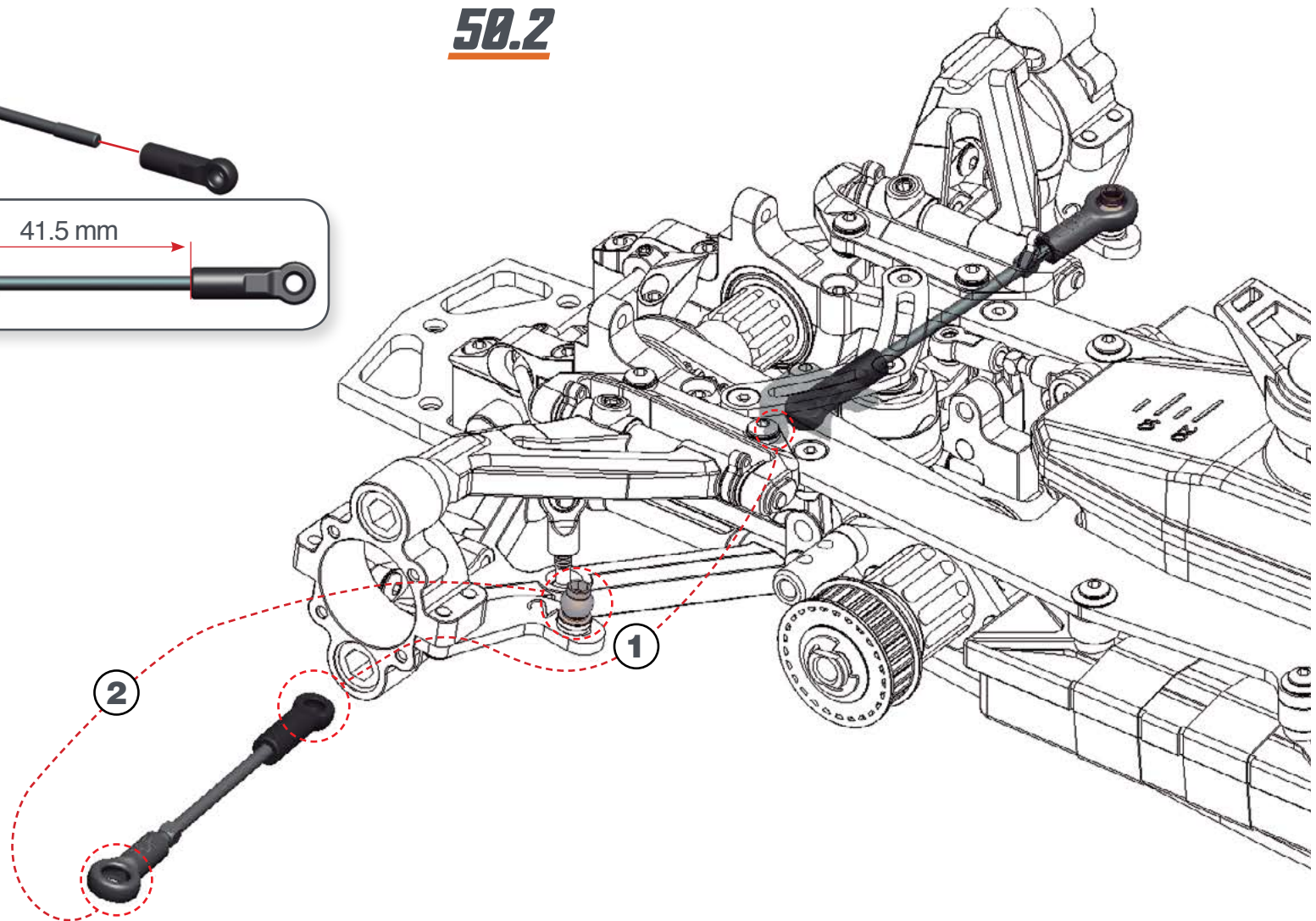

**STEP 51 BAG 13**

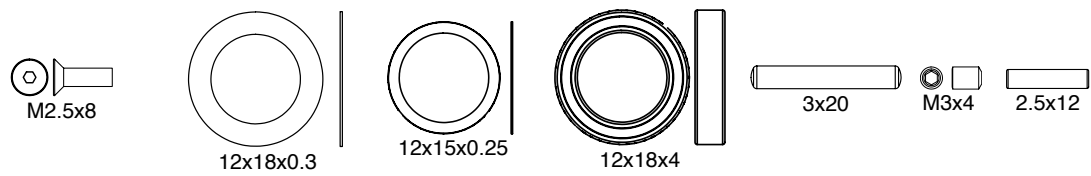
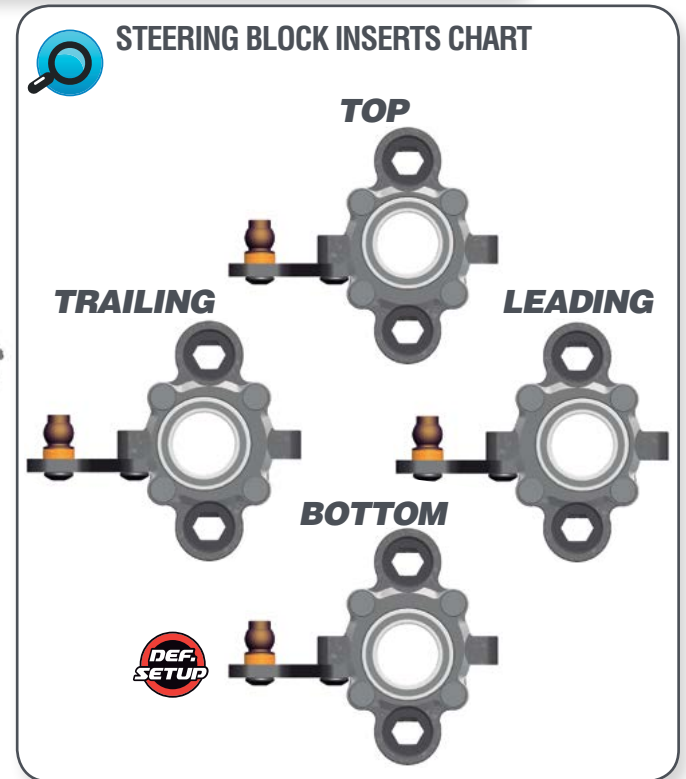
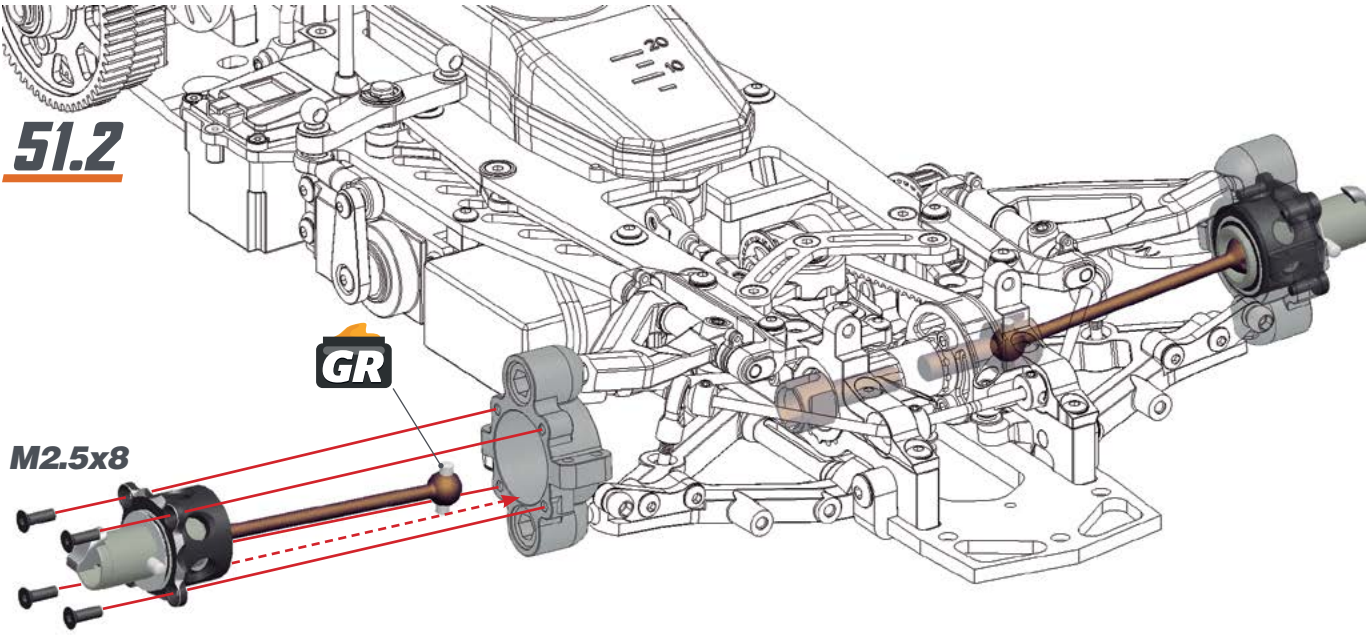
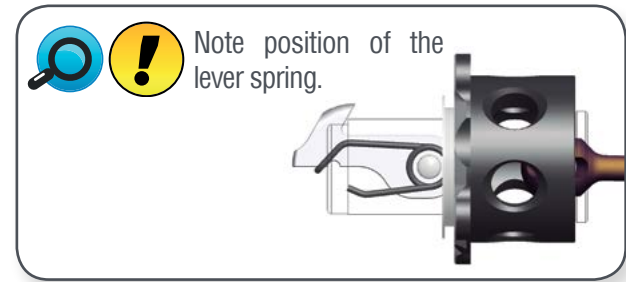
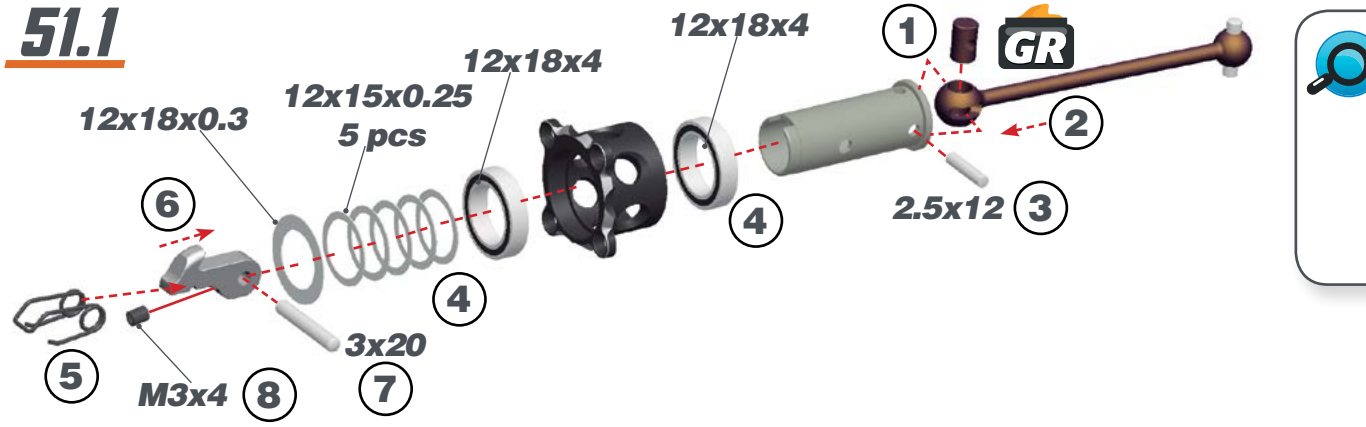

## STEP 52 SHOCKS BAG

### 52.1

Use some silicone oil during the assembly.

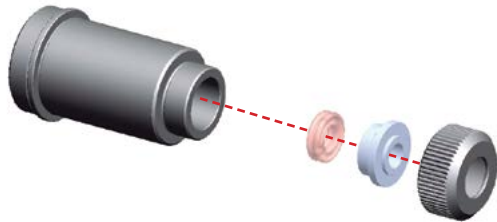

Note the correct orientation of the shock spacers.

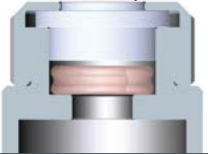

### 52.2

Insert the o-ring inside the spring collar.

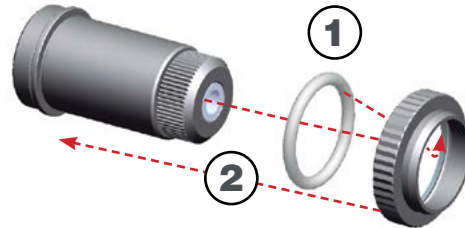

Note the correct position of the o-ring.



## STEP 53

### 53.1

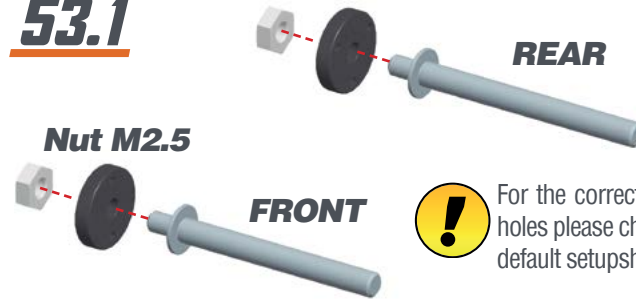

Nut M2.5



For the correct piston holes please check the default setupsheet.



Use the shorter shock shaft in the front and the longer one in the rear shock absorber.

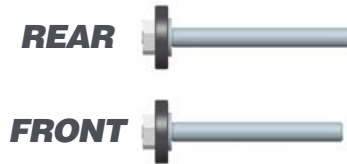

### 53.2

Use some silicone oil during the assembly.

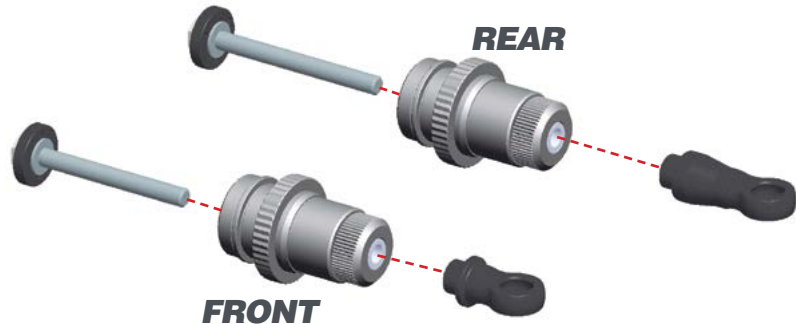

Nut M2.5



## STEP 54

### 54.1

Push the shock top and the membrane into the shock cap.



### 54.2

1- Fill up with silicone oil fully using the silicone oil supplied in the kit. For the correct cst value please check the default setupsheet.

2- Extend the shockrod fully

3- Move the shockrod slowly up and down to let ALL air bubbles escape.

4- Close top only 3/4.

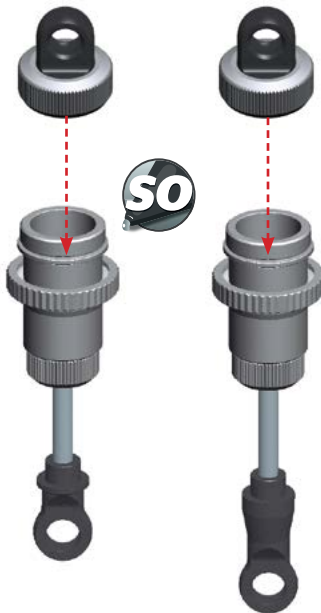

### 54.3

1-Bleed: push the shockrod all the way in slowly, to allow excessive oil to escape.

2- Close the shock cap completely.



**SHOCKS LENGTH:** Measure the shock length fully extended.

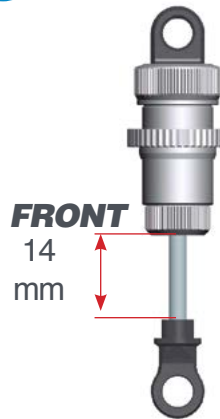

**FRONT**  
14  
mm

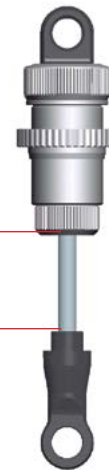

**REAR**  
15.5  
mm

## STEP 55

Assemble the spring and spring-cup (align correctly) to complete the shock.

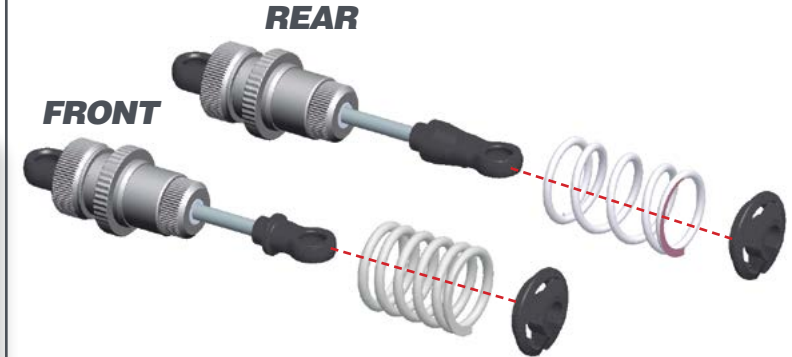

**FRONT**

**REAR**

STEP 56 BAG 14

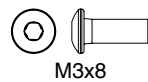
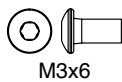
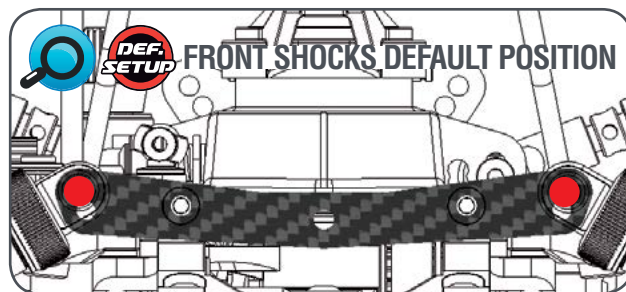
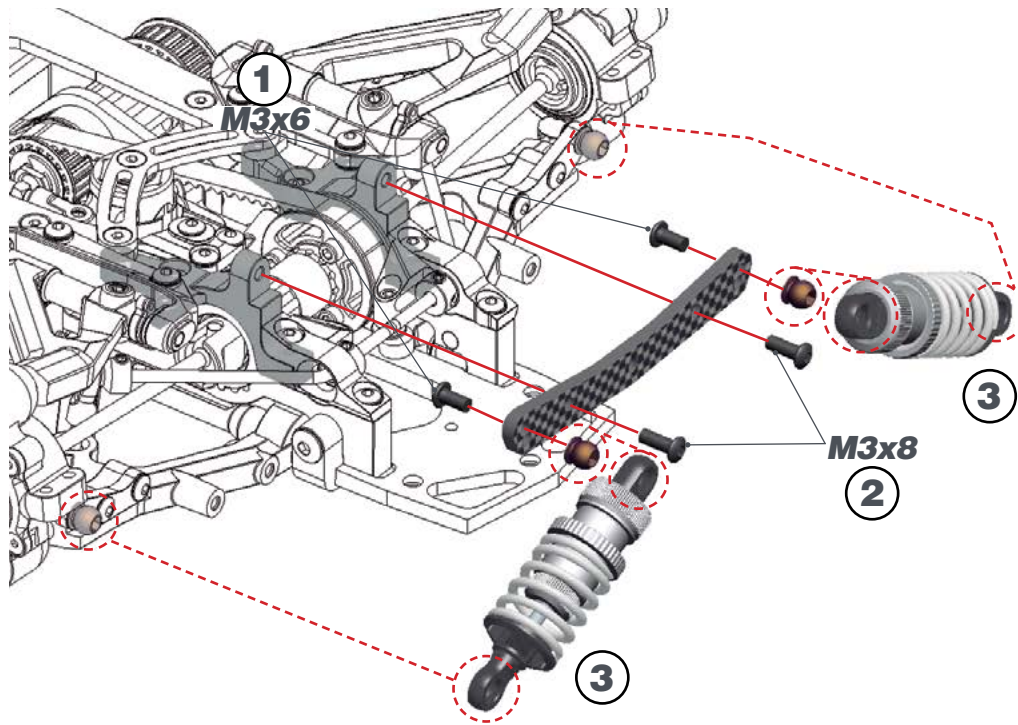

STEP 57

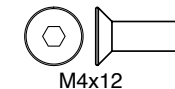
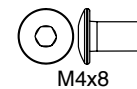
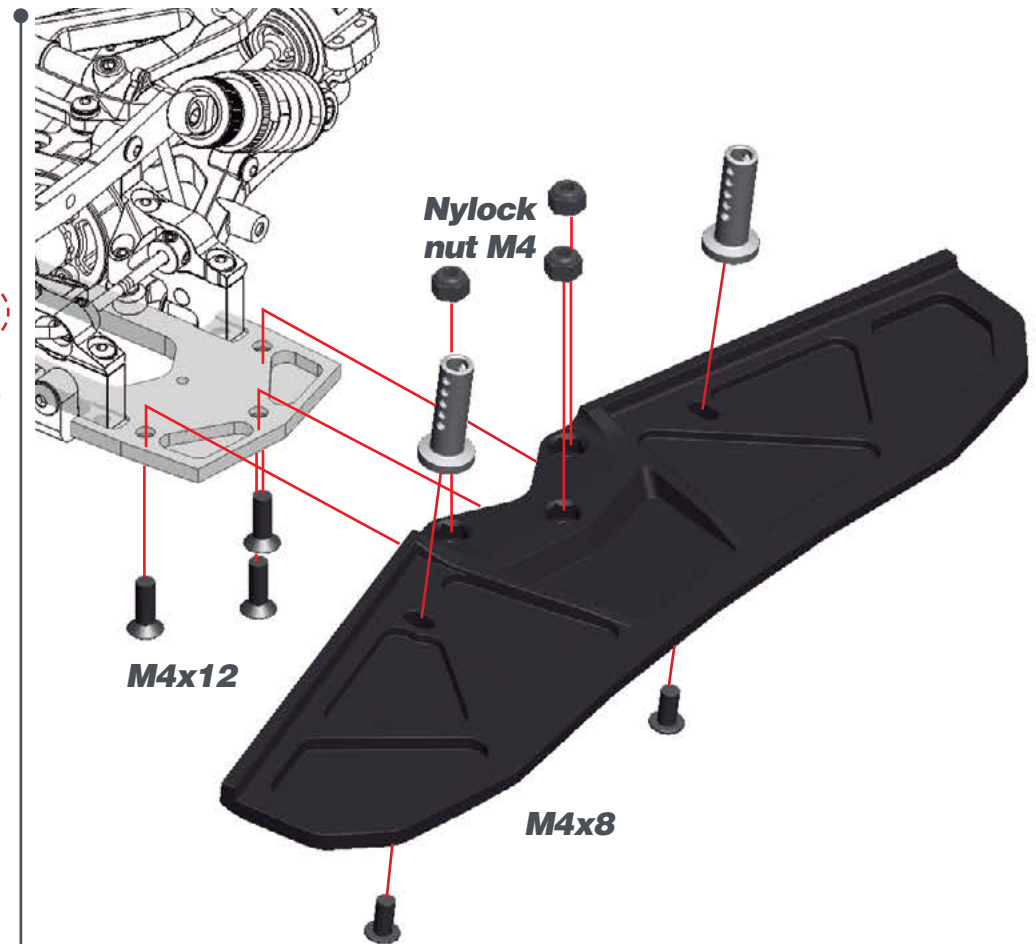

STEP 58

! Do not overtighten the M3x10 screws to prevent binding.

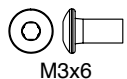
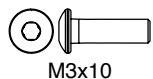
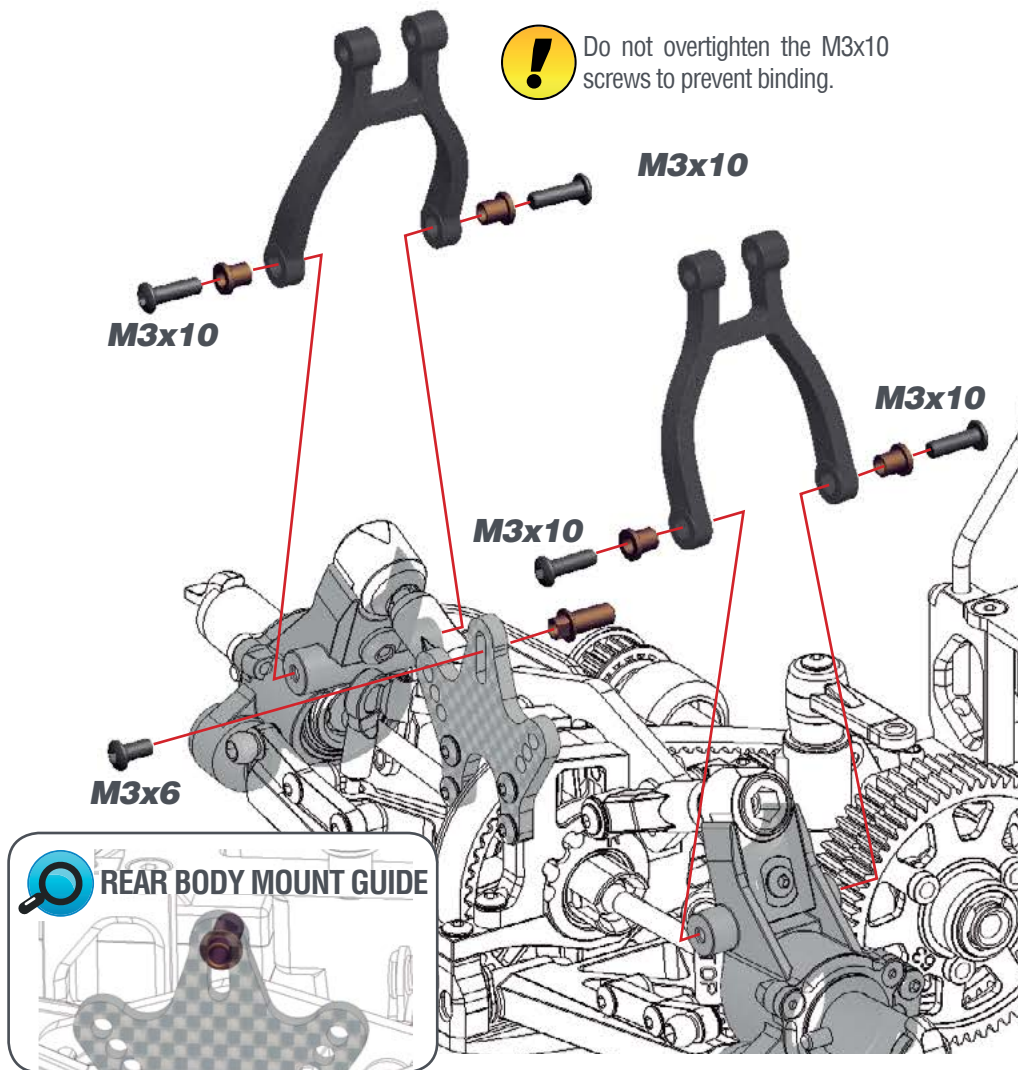

STEP 59

! Do not overtighten M3x6 Flanged screws.

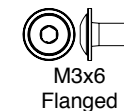
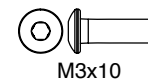
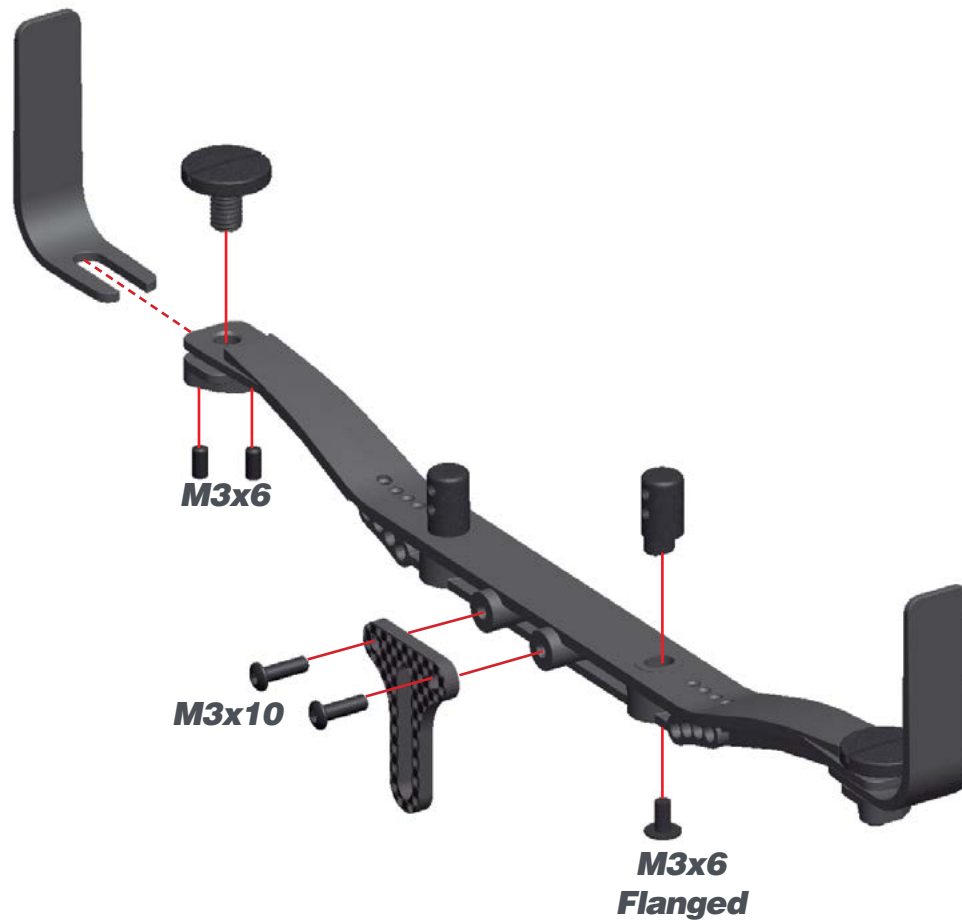



STEP 60

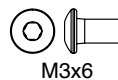
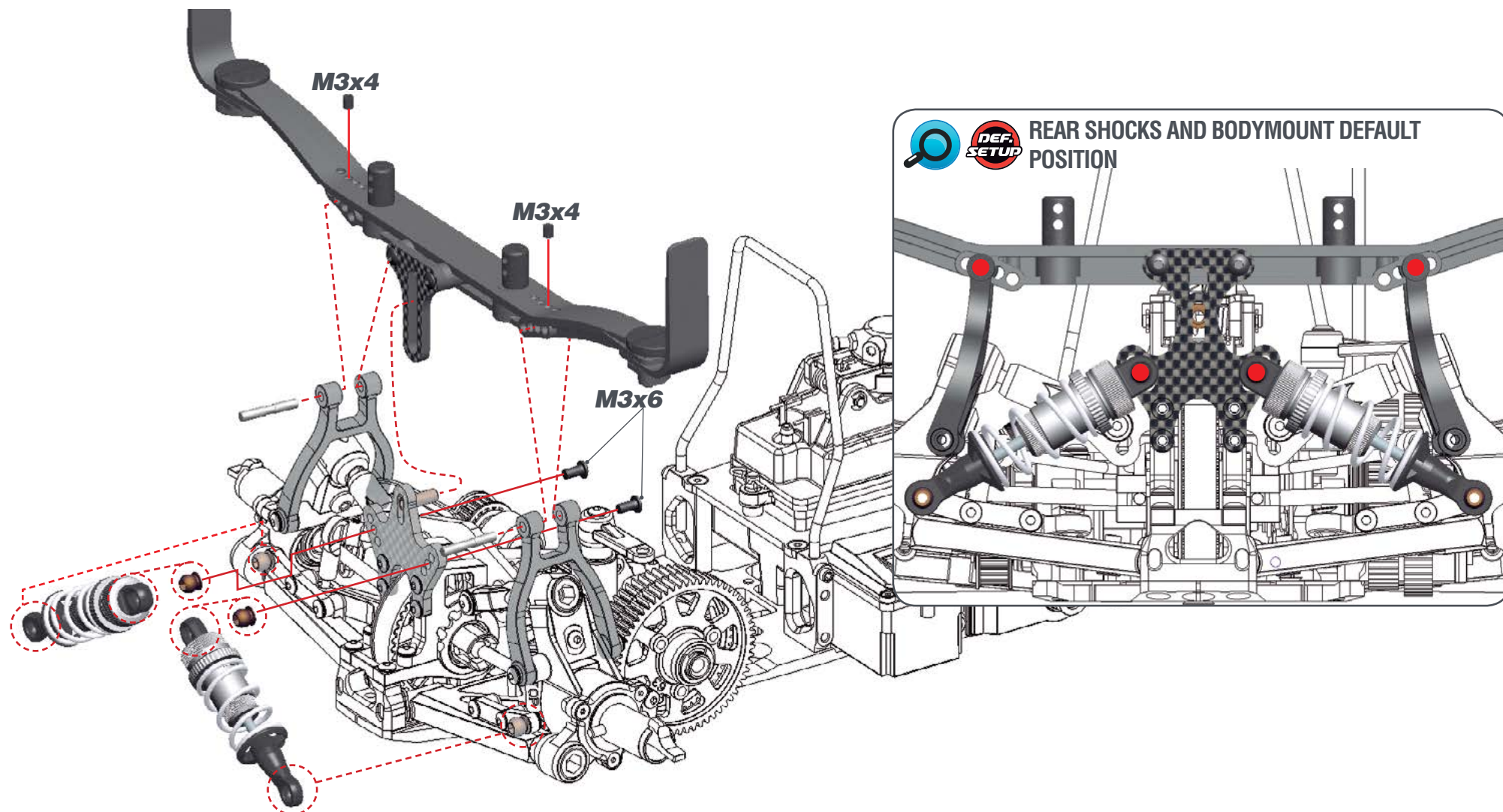

## STEP 61 CLUTCH BAG

### 61.1

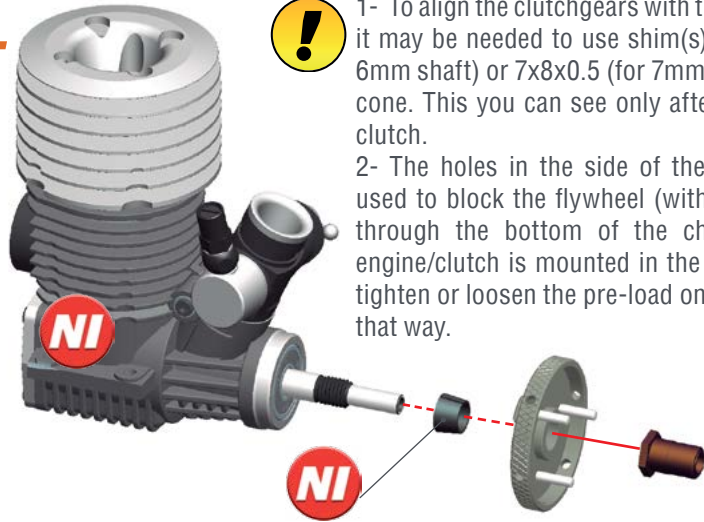

1- To align the clutchgears with the 2-speed gears, it may be needed to use shim(s) 6x8x0.5mm (for 6mm shaft) or 7x8x0.5 (for 7mm shaft) behind the cone. This you can see only after assembling the clutch.

2- The holes in the side of the flywheel can be used to block the flywheel (with short allen tool) through the bottom of the chassis, when the engine/clutch is mounted in the car. It's easier to tighten or loosen the pre-load on the clutch spring that way.



### 61.2

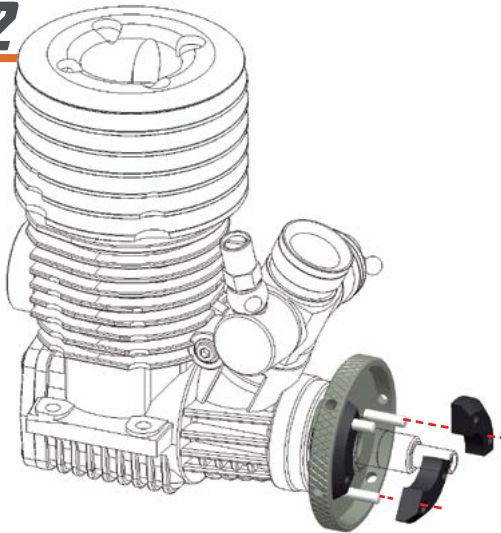

Note the orientation of the flyweights. Use the right hole for having a more aggressive clutch

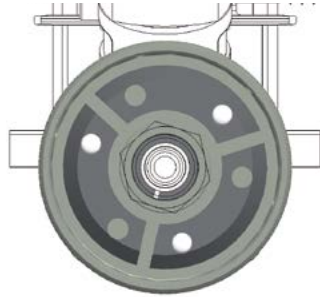

## STEP 62

### 62.1

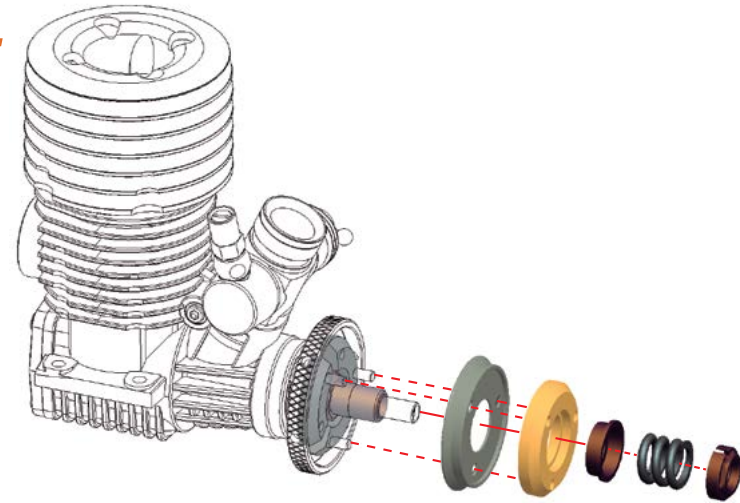

### 62.2



For adjusting the default clutch spring tension:

- 1- Screw in the adjusting nut all the way.
- 2- Unscrew it one and a half turns.
- 3- Fine tune the setup of your clutch on the track according to your driving style, track and weather conditions.

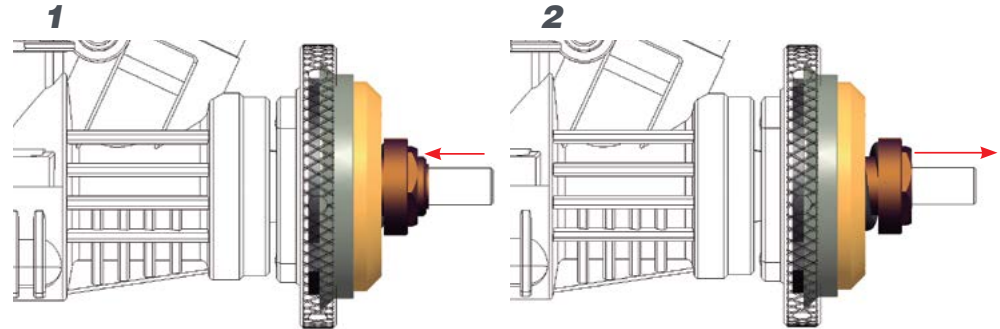

## STEP 63

### 63.1

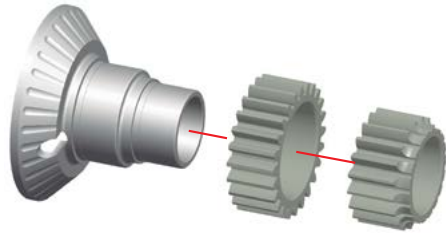

### 63.2 SETTING THE CLUTCH GAP

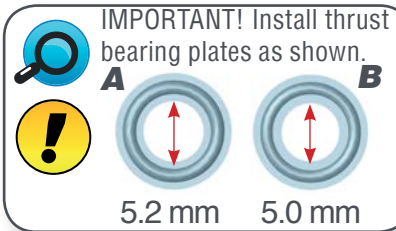
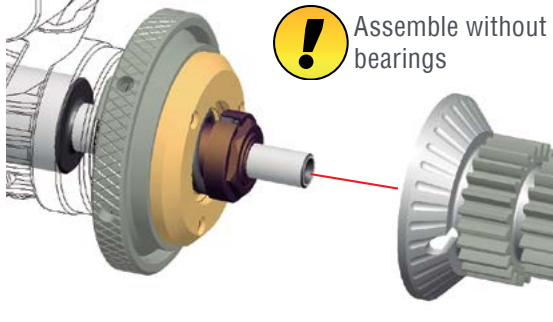

**63.2** Clutch gap is calculated taking A and B measurements showed below.  
 $GAP = B - A$ . The advised gap is between 0.6 and 0.8mm

Pull the clutch bell forward

Push the clutchbell back

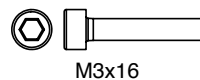
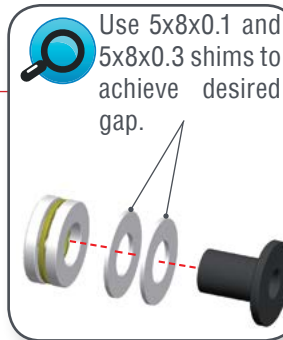
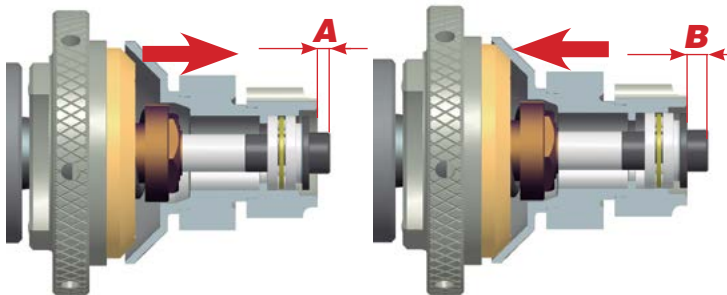

## STEP 64

### 64.1

Disassemble the clutch bell.

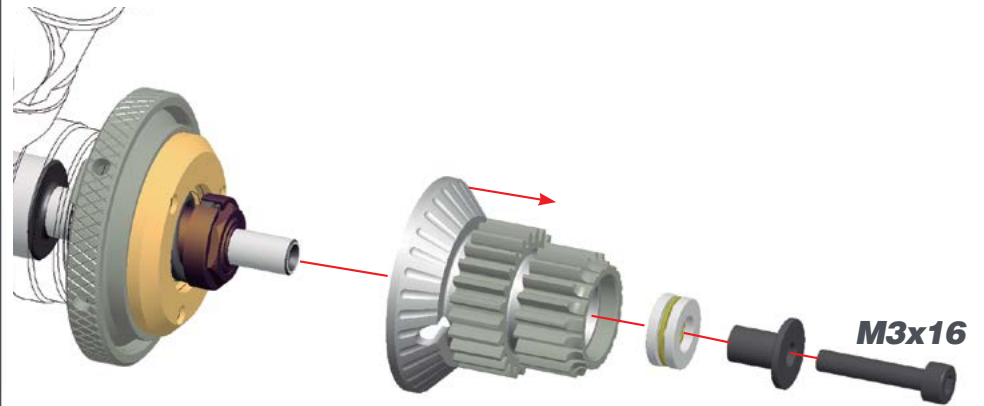

### 64.2 SETTING THE CLUTCH END PLAY

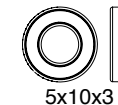



## STEP 65 BAG 15

### 65.1

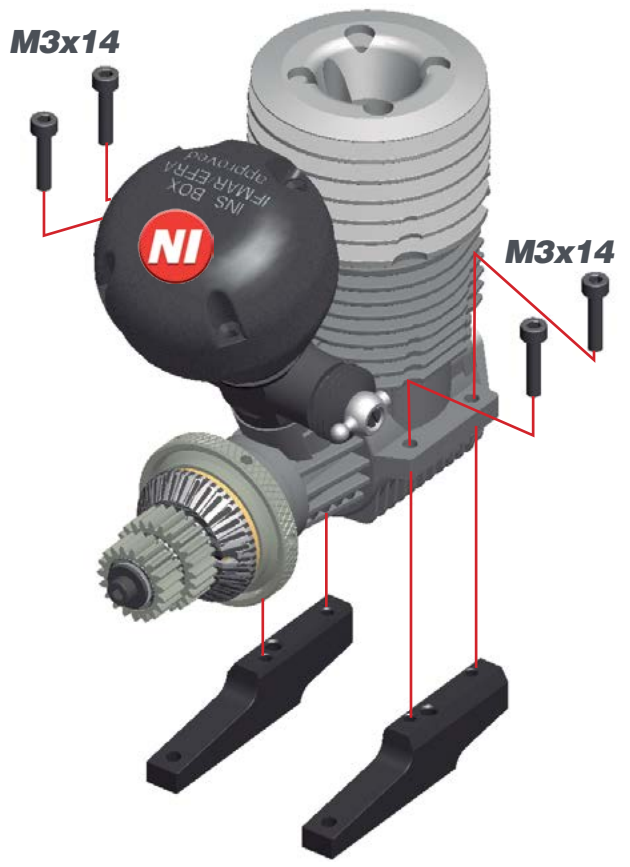

### 65.2

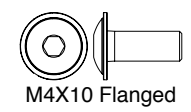
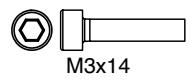
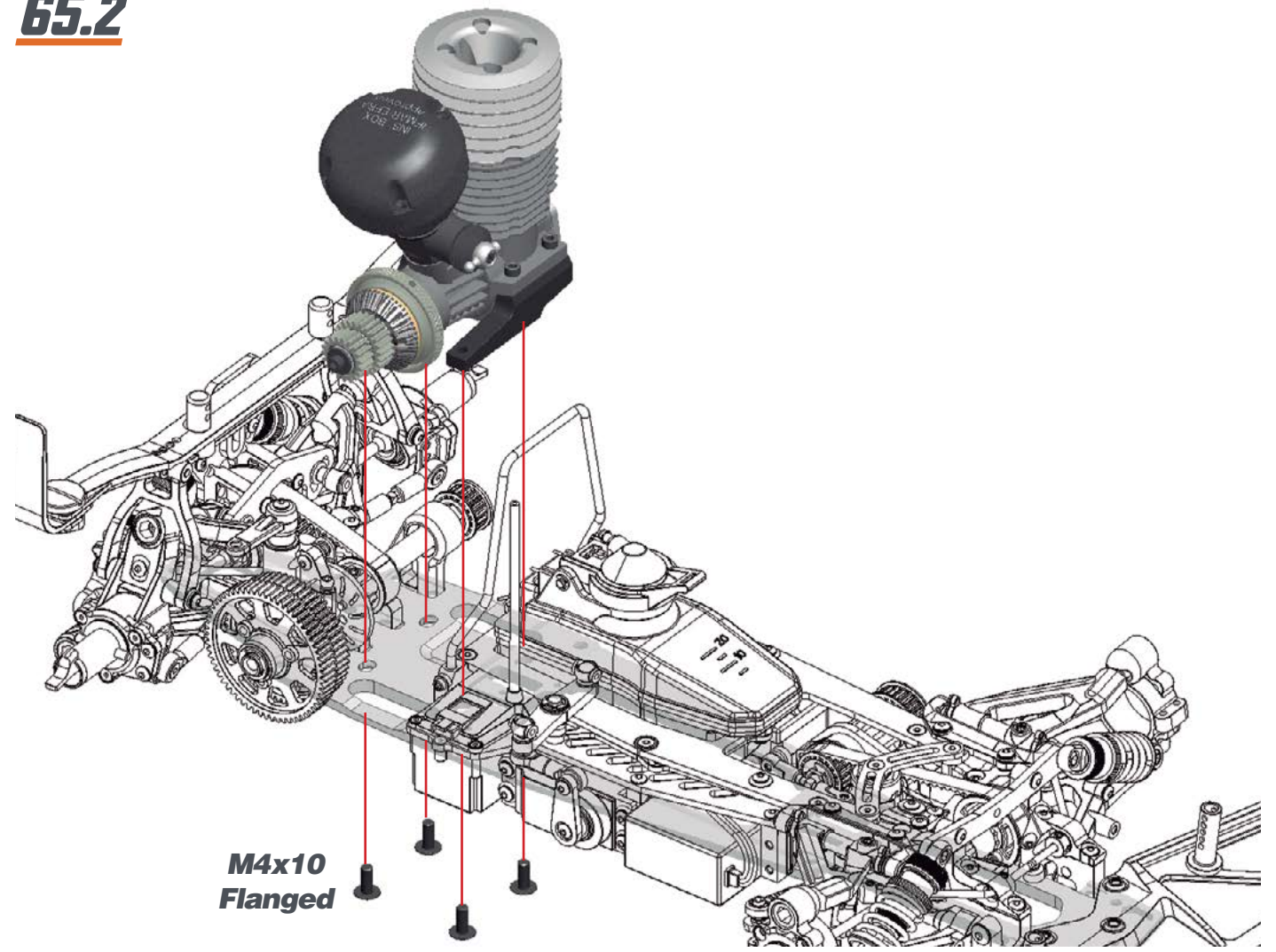

STEP 66

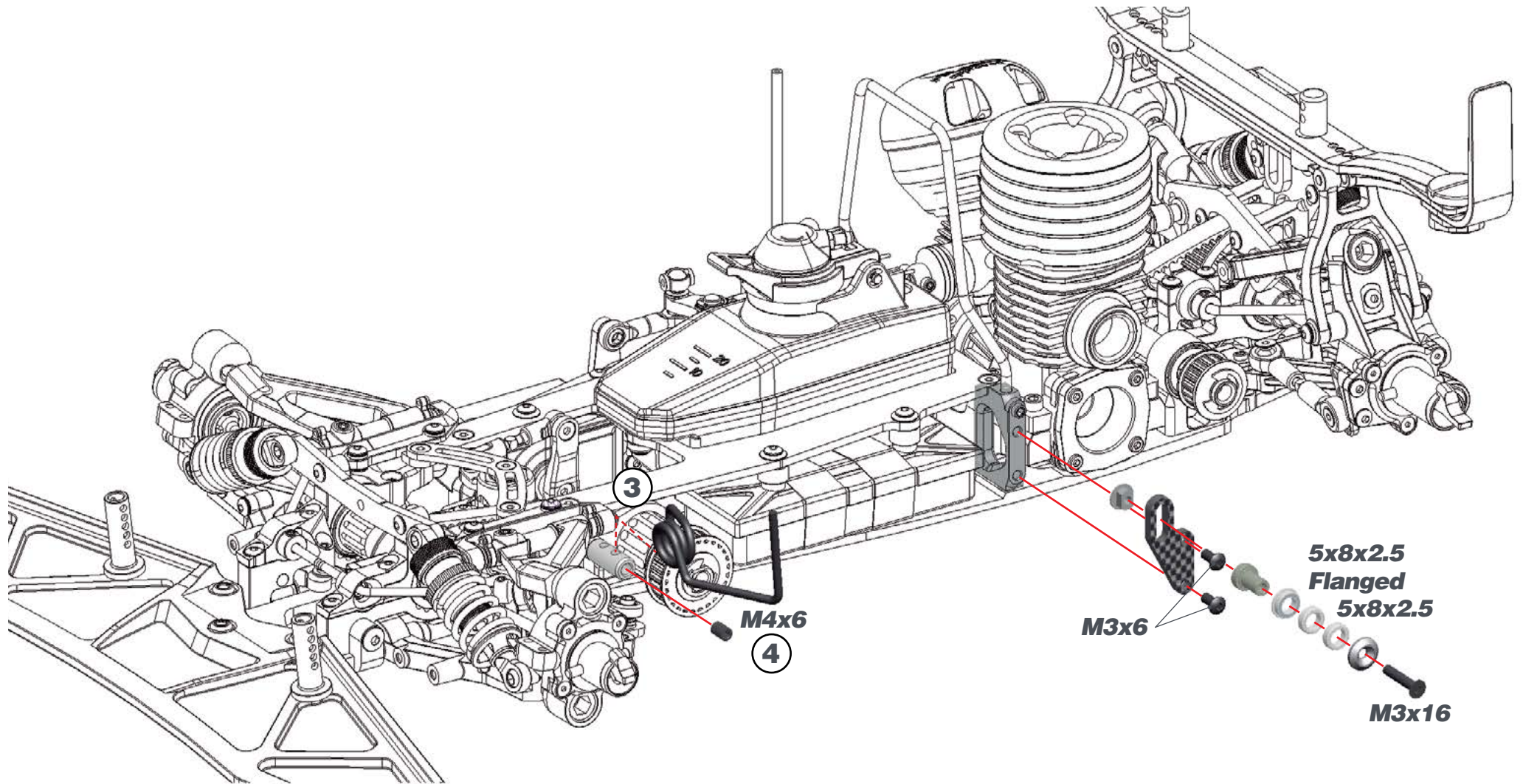

M4x6



M3x6



5X8X2.5 Flanged



5x8x2.5

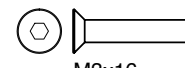

M3x16



**STEP 67**

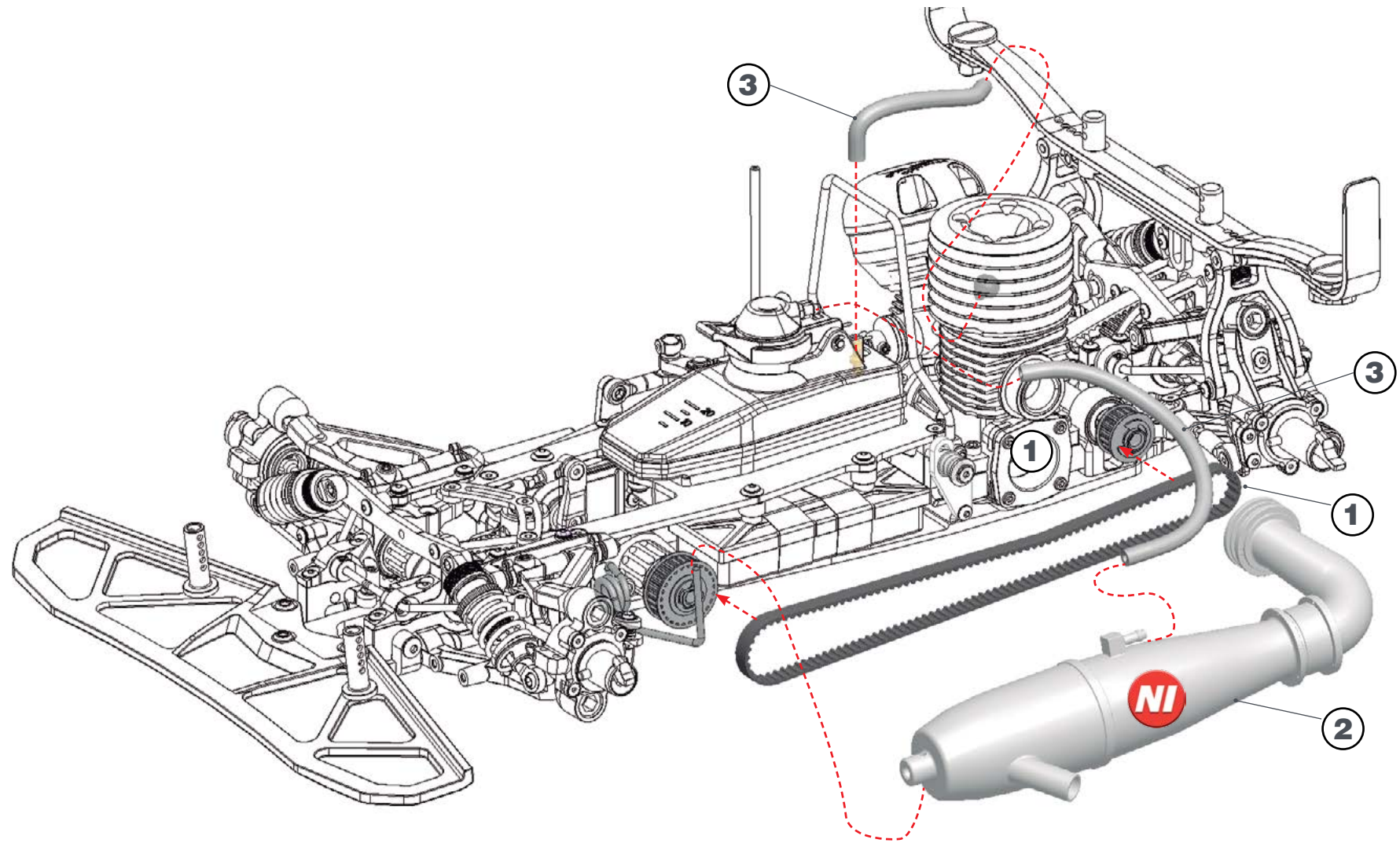



# STEP 68

## 68.1

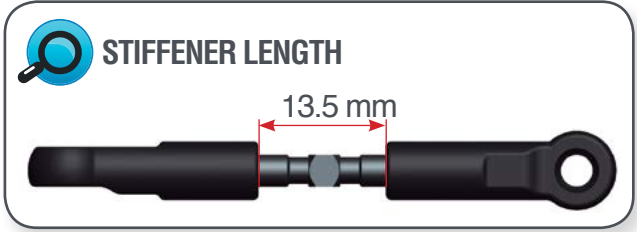

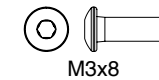
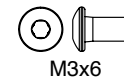
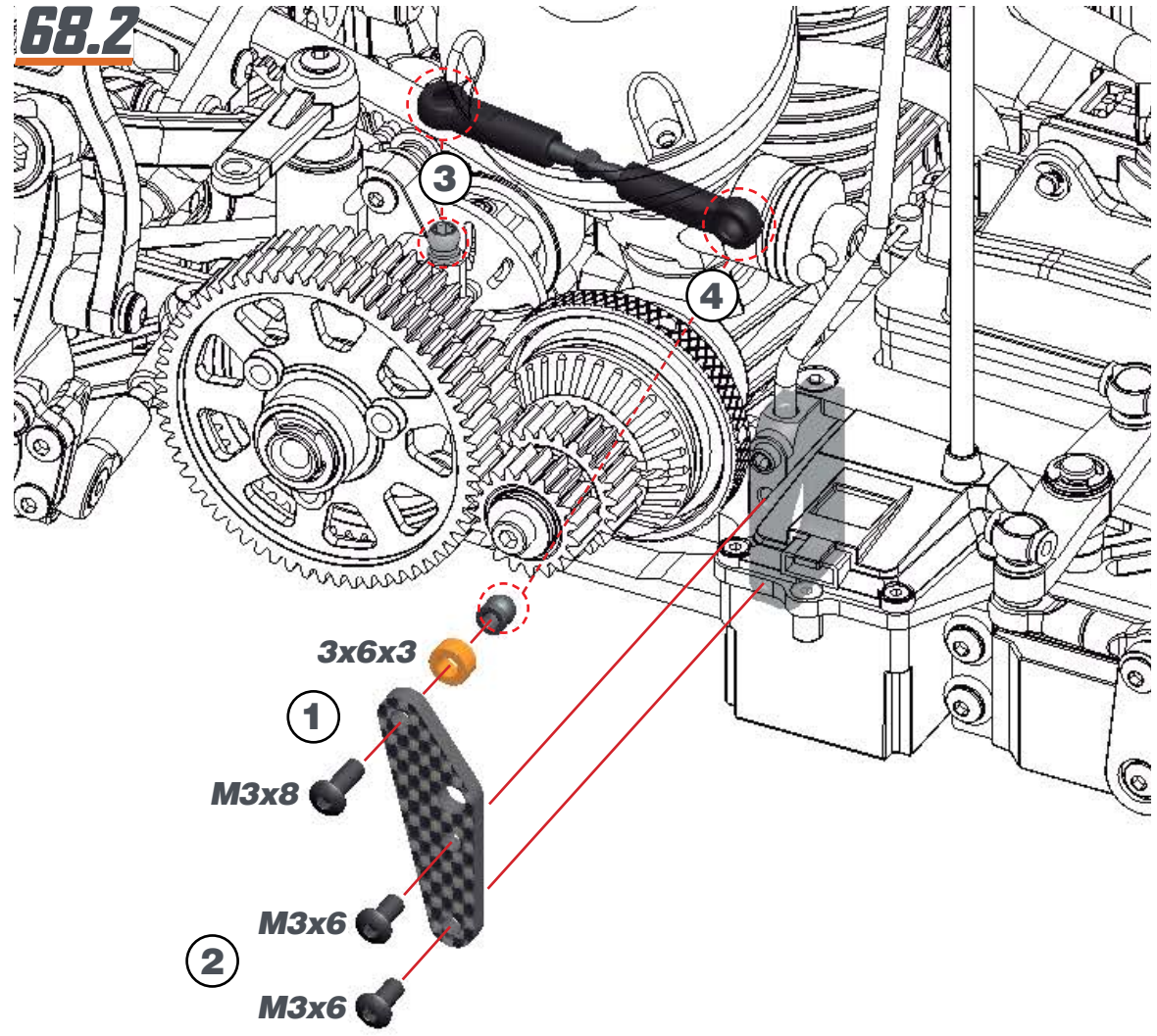

## 68.2

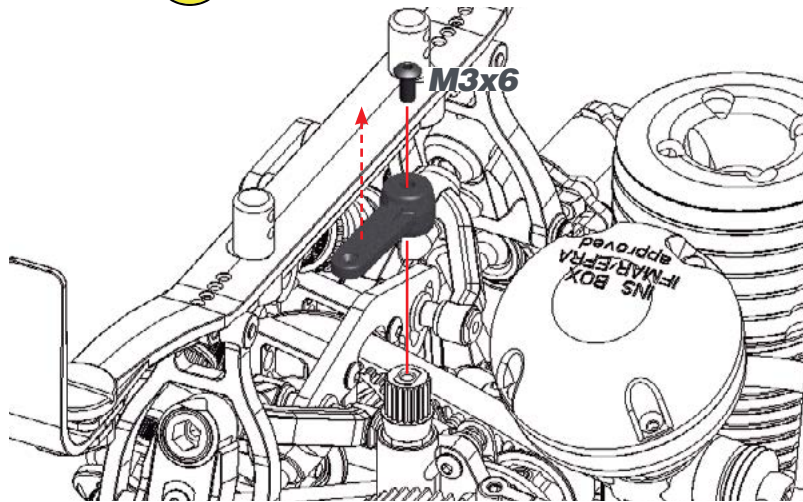

# STEP 69

**69.1**  Disassemble the plastic brake lever.



**69.2**  Pass the brake linkage through the plastic brake lever.

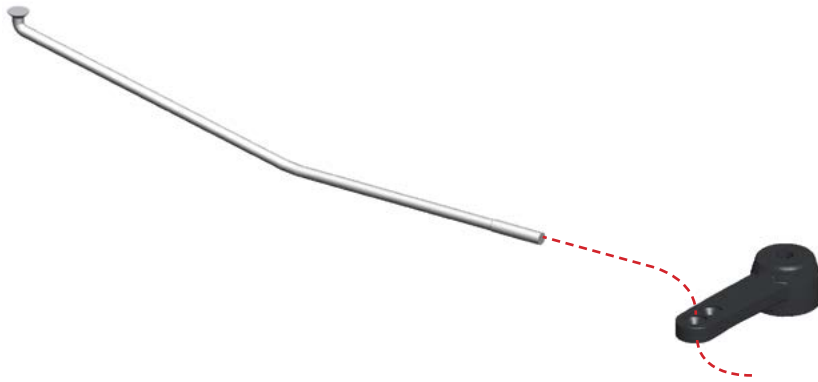

**69.3**

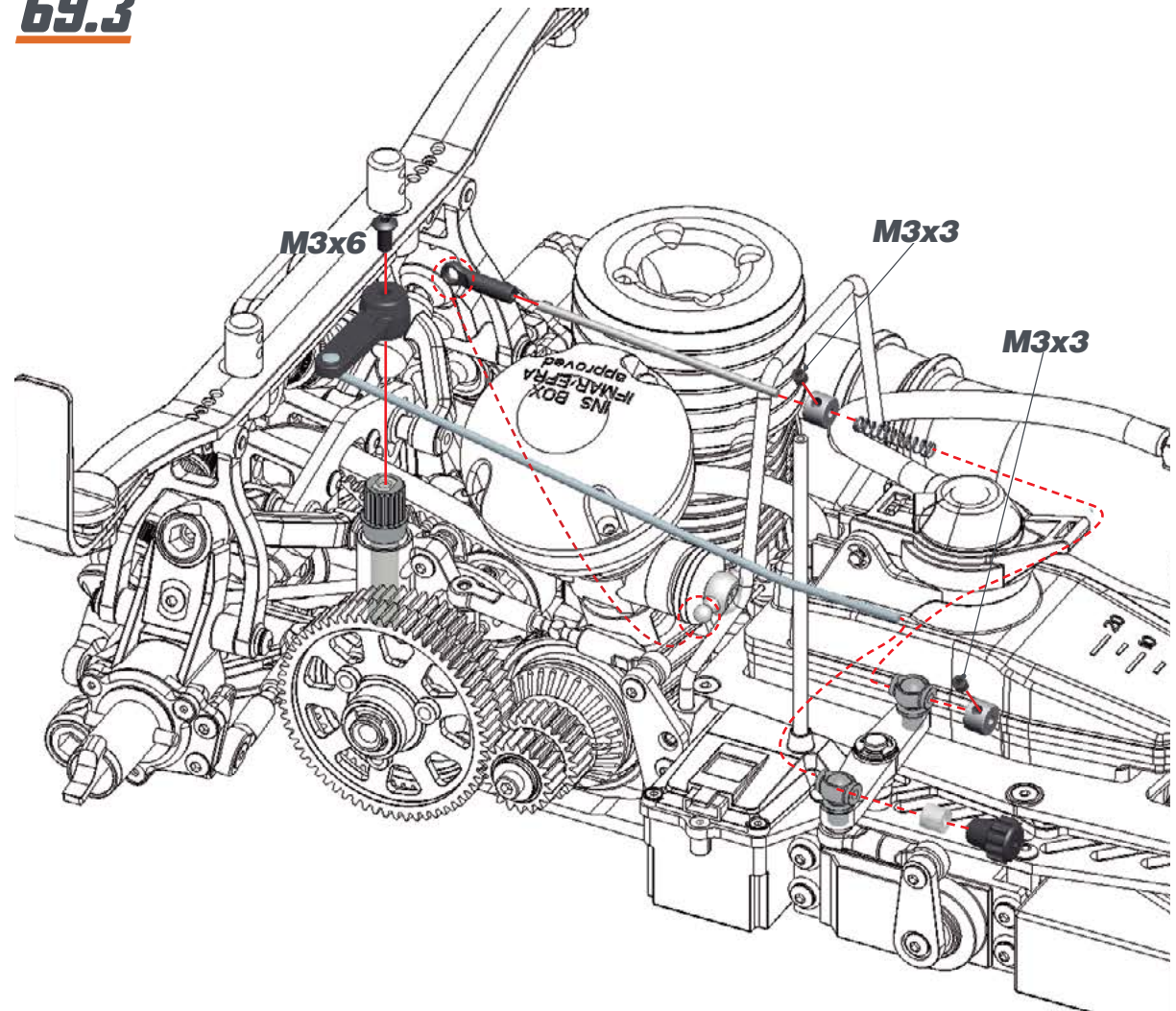

   
M3x3



**STEP 70**

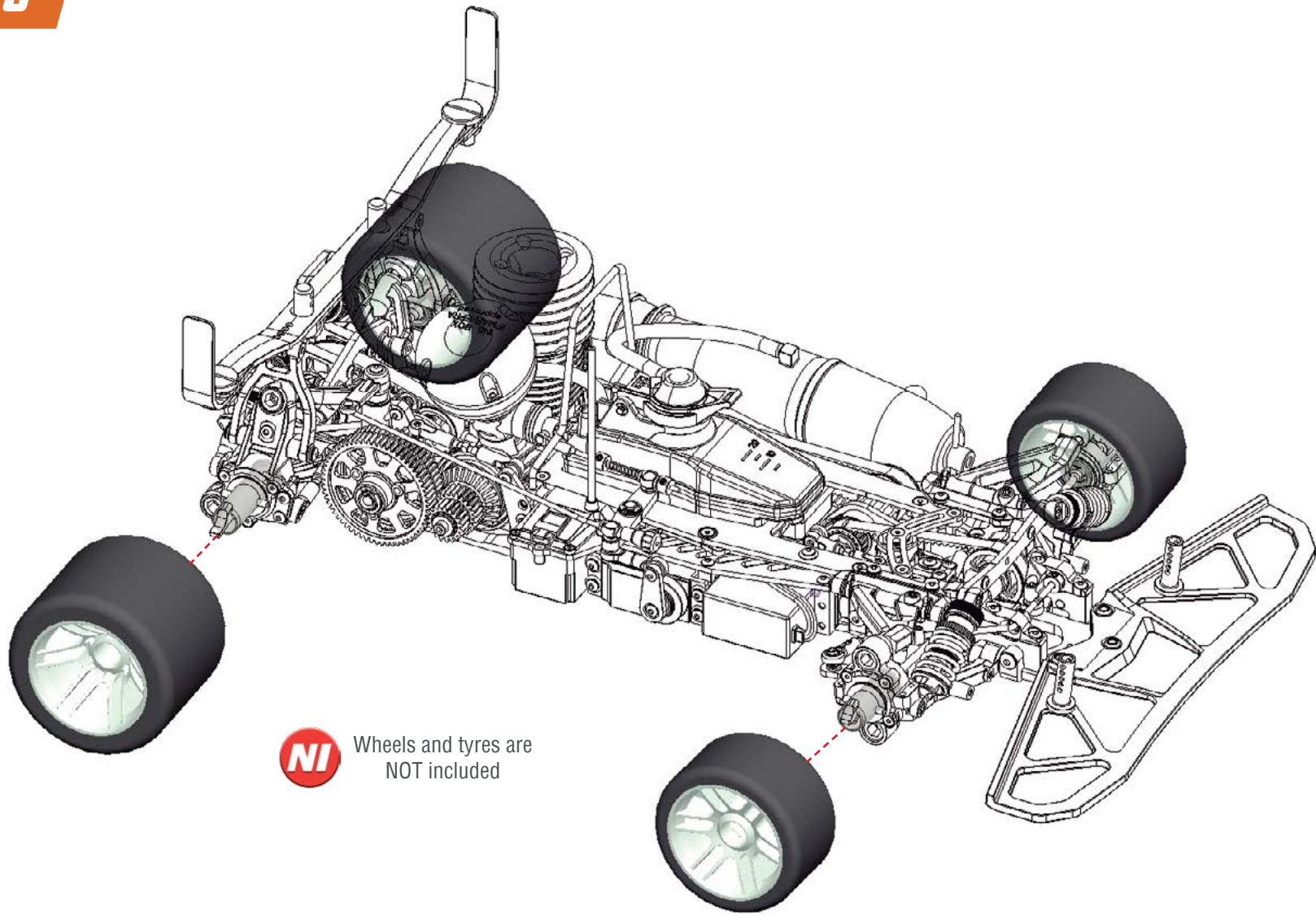

Wheels and tyres are  
NOT included



## INDEX

<b>CLUTCH AND GEARBOX EXPLODED VIEW</b>	<b>51</b>
<b>SHOCKS EXPLODED VIEW</b>	<b>52</b>
<b>RR UPRIGHTS AND FR STEERING BLOCKS EXP. VIEW</b>	<b>53</b>
<b>REAR EXPLODED VIEW</b>	<b>54</b>
<b>FRONT 1 EXPLODED VIEW</b>	<b>55</b>
<b>RADIO 1 EXPLODED VIEW</b>	<b>56</b>
<b>RADIO 2 EXPLODED VIEW</b>	<b>57</b>
<b>FRONT 2 EXPLODED VIEW</b>	<b>58</b>
<b>BUMPER AND BODYMOUNT EXPLODED VIEW</b>	<b>59</b>
<b>FINAL EXPLODED VIEW</b>	<b>60</b>
<b>TEAM SERPENT NETWORK</b>	<b>61</b>



#903810 Lightweight 2-speed shaft set S989

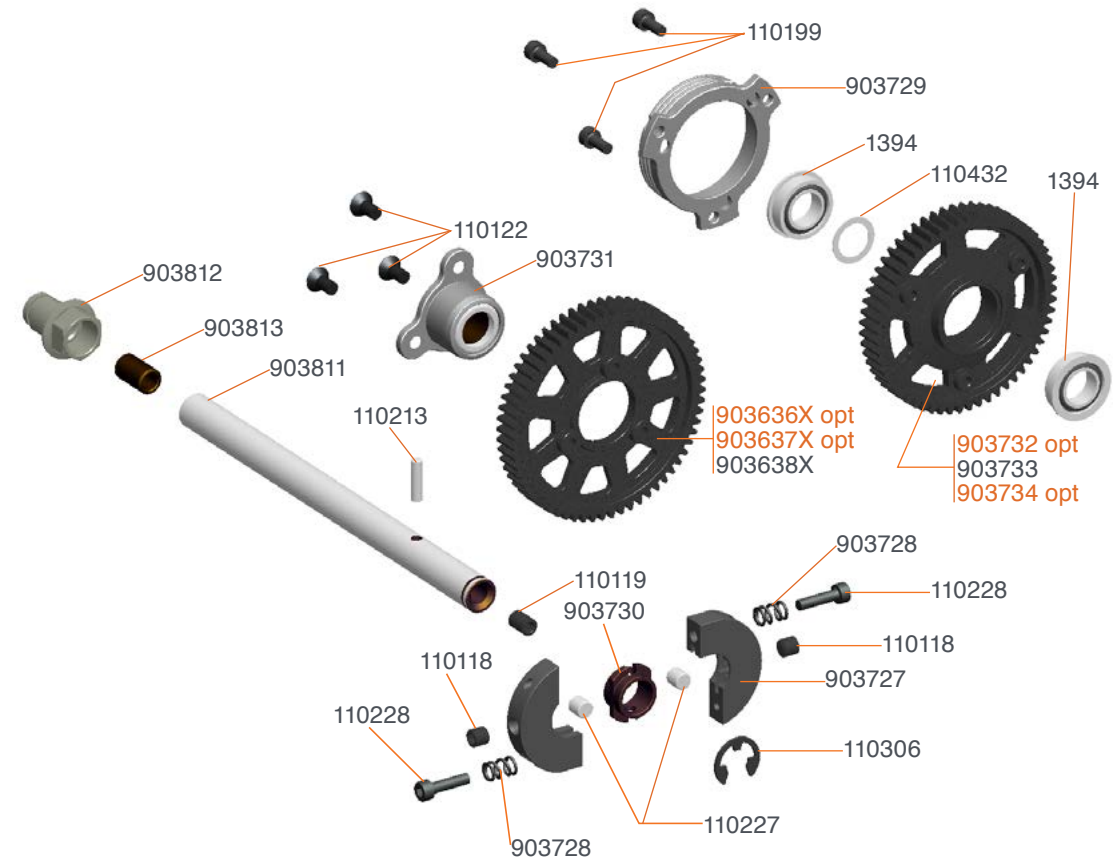

6587XP Centax clutch shoe XP	903637X 2-speed gear 62T SL8 XLI V2	903796 Centax spring XX-hard
903239 Centax-2 clutch shoe red	903732 2-speed gear 56T XLI Gen2	903799 Centax gear-pinion alu 18T XLI Gen2
903643 Centax gear-pinion alu 23T XLI	903734 2-speed gear 58T XLI Gen2	903801 Centax gear-pinion alu 20T XLI Gen2
903645 Centax gear-pinion alu 25T XLI	903771 2-speed gear set (6) XLI Gen2	
903646 Centax gear-pinion alu set XLI (6)	903805 Centax gear-pinion alu set XLI Gen2 (6)	
903636X 2-speed gear 61T SL8 XLI V2	909512 Centax II clutch-housing universal	

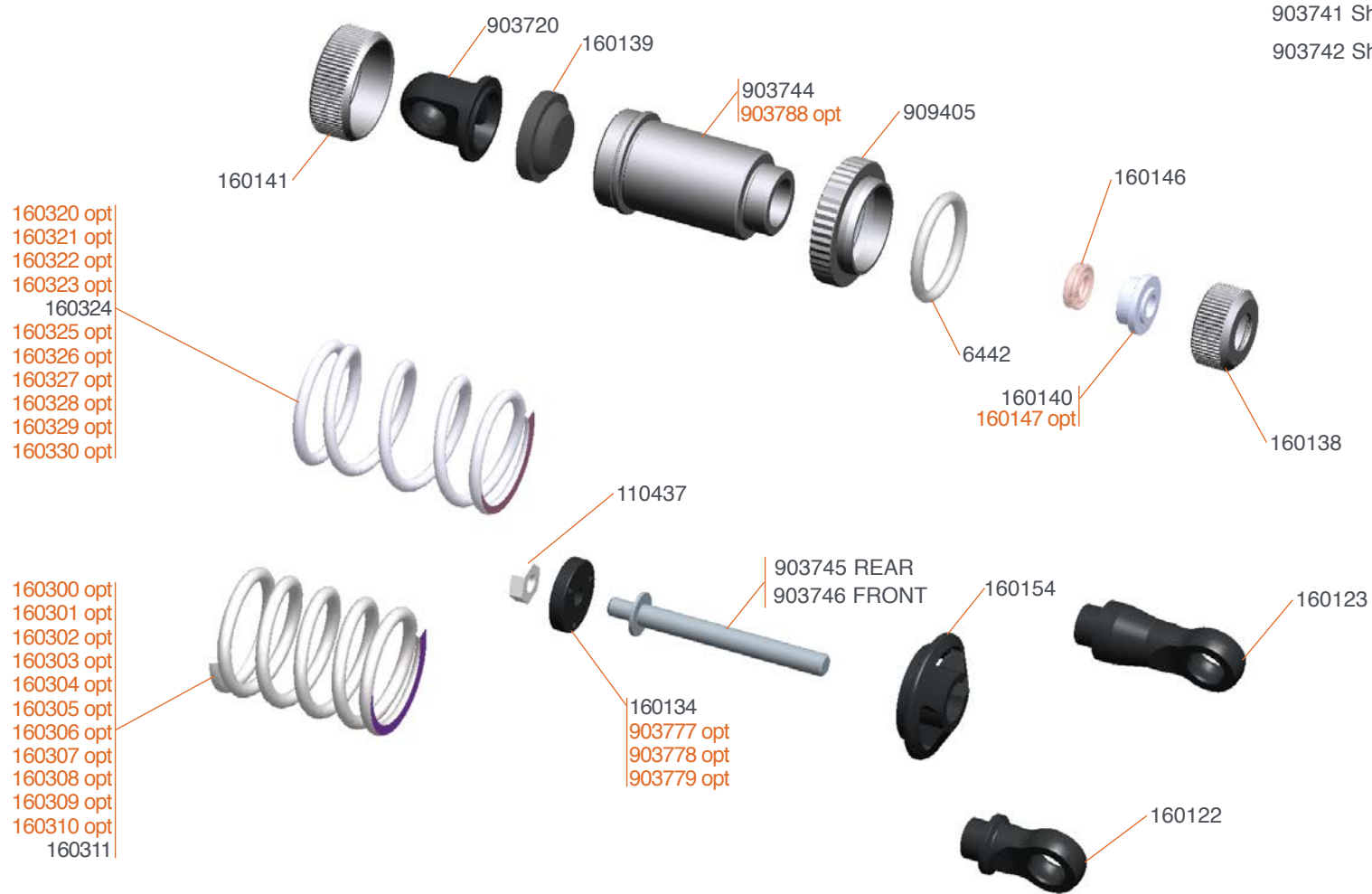

903741 Shockset XLV short (2)

903742 Shockset XLV long (2)

- 160147 Shock onroad big bore bushing LF (4)
- 160300 Spring white L23 (2.3/13) (2)
- 160301 Spring yellow L23 (2.8/16) (2)
- 160302 Spring orange L23 (3.4/19.5) (2)
- 160303 Spring red L23 (4.1/23.5) (2)
- 160304 Spring pink L23 (4.0/28) (2)
- 160305 Spring blue L23 (5.8/33) (2)
- 160306 Spring purple L23 (6.8/39) (2)
- 160307 Spring green L23 (8/45.5) (2)
- 160308 Spring grey L23 (9/51.5) (2)

- 160309 Spring black L23 (10/57) (2)
- 160310 Spring-set short (5x2)
- 160320 Spring white L27 (2.3/13) (2)
- 160321 Spring yellow L27 (2.8/16) (2)
- 160322 Spring orange L27 (3.4/19.5) (2)
- 160323 Spring red L27 (4.1/23.5) (2)
- 160325 Spring blue L27 (5.8/33) (2)
- 160326 Spring purple L27 (6.8/39) (2)
- 160327 Spring green L27 (8/45.5) (2)
- 160328 Spring grey L27 (9/51.5) (2)

- 160329 Spring black L27 (10/57) (2)
- 160330 Spring-set L27 (5x2)
- 903777 Shock piston XLV 1 hole (4)
- 903778 Shock piston XLV 2 hole (4)
- 903779 Shock piston XLV 3 hole (4)
- 903780 Heave demper set rear
- 903781 Heave demper set front
- 903788 Shockbody XLV short NiCoated (2)





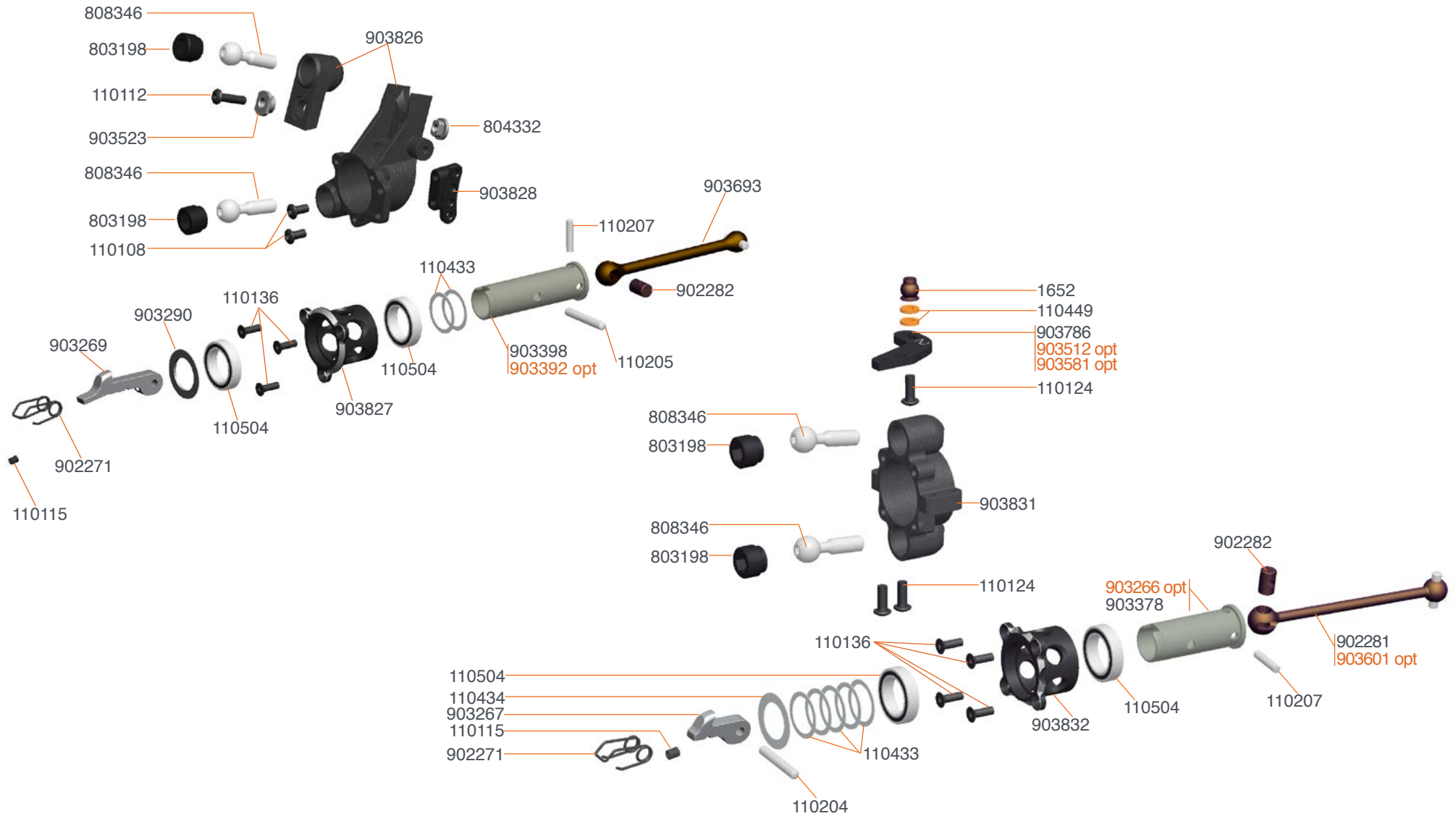

- 903392 Wheel-axle CVD RR (2)
- 903266 Wheel-axes cvd OS2 FR (2)
- 903512 Steeringblock lever alu (2)
- 903581 Steeringblock lever carbon (2)
- 903601 Driveshaft cvd FR alu (2)





# FRONT 1 EXPLODED VIEW

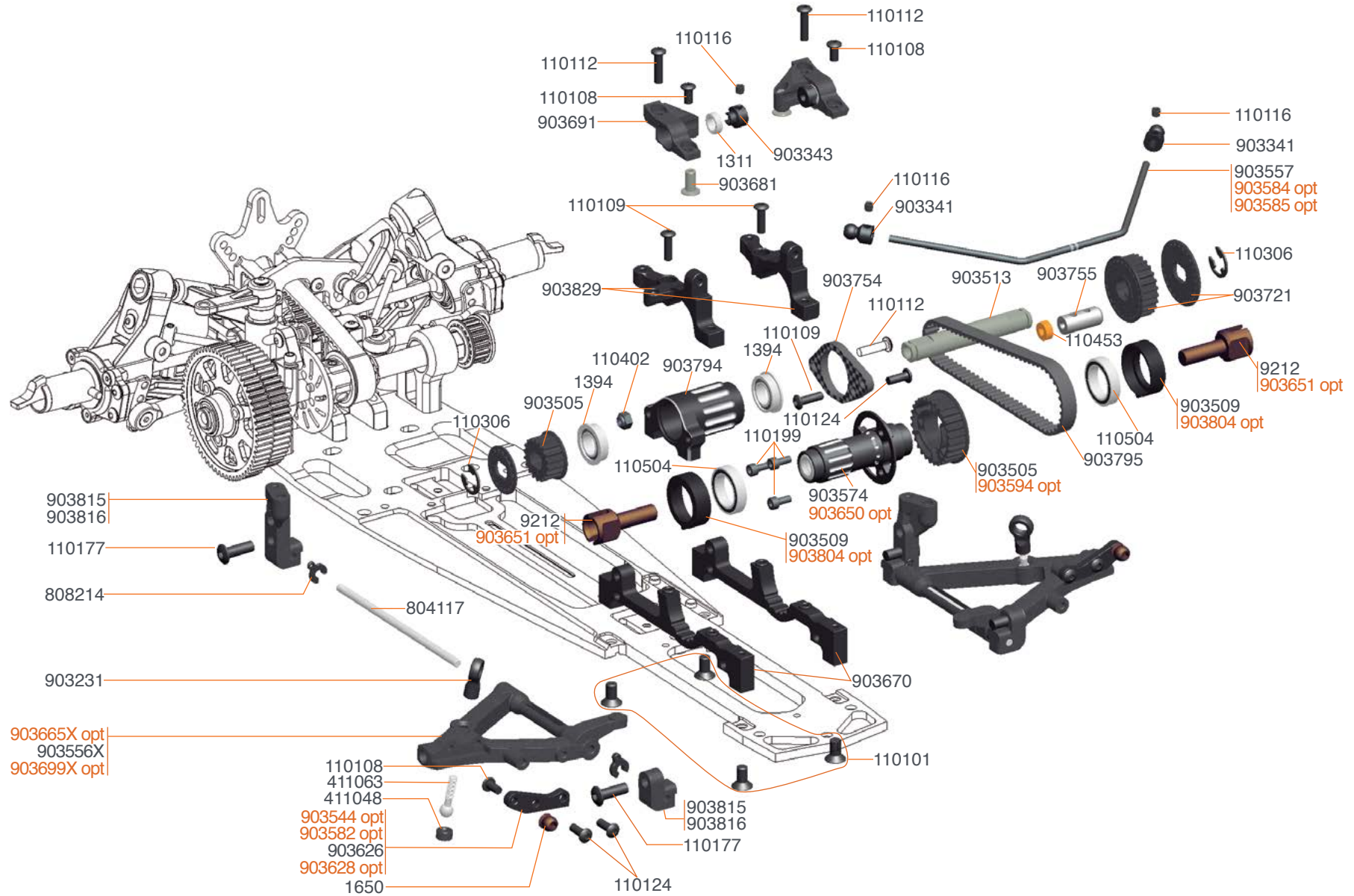

- 903544 Shock extension bracket FR alu (2)
- 903584 Antirroll bar FR soft S989
- 903585 Antirroll bar FR hard S989
- 903582 Shock extension bracket FR carbon (2)

- 903628 Shock extension bracket FR wide carbon (2)
- 903650 Oneway front axle Hard anodized
- 903651 Inner driveshaft adapter light
- 903665X Wishbone FR lw V2 L+R S988

- 903695 Wishbone insert carbon FR lw (2)
- 903699X Wishbone FR lw V2 L+R hard S988





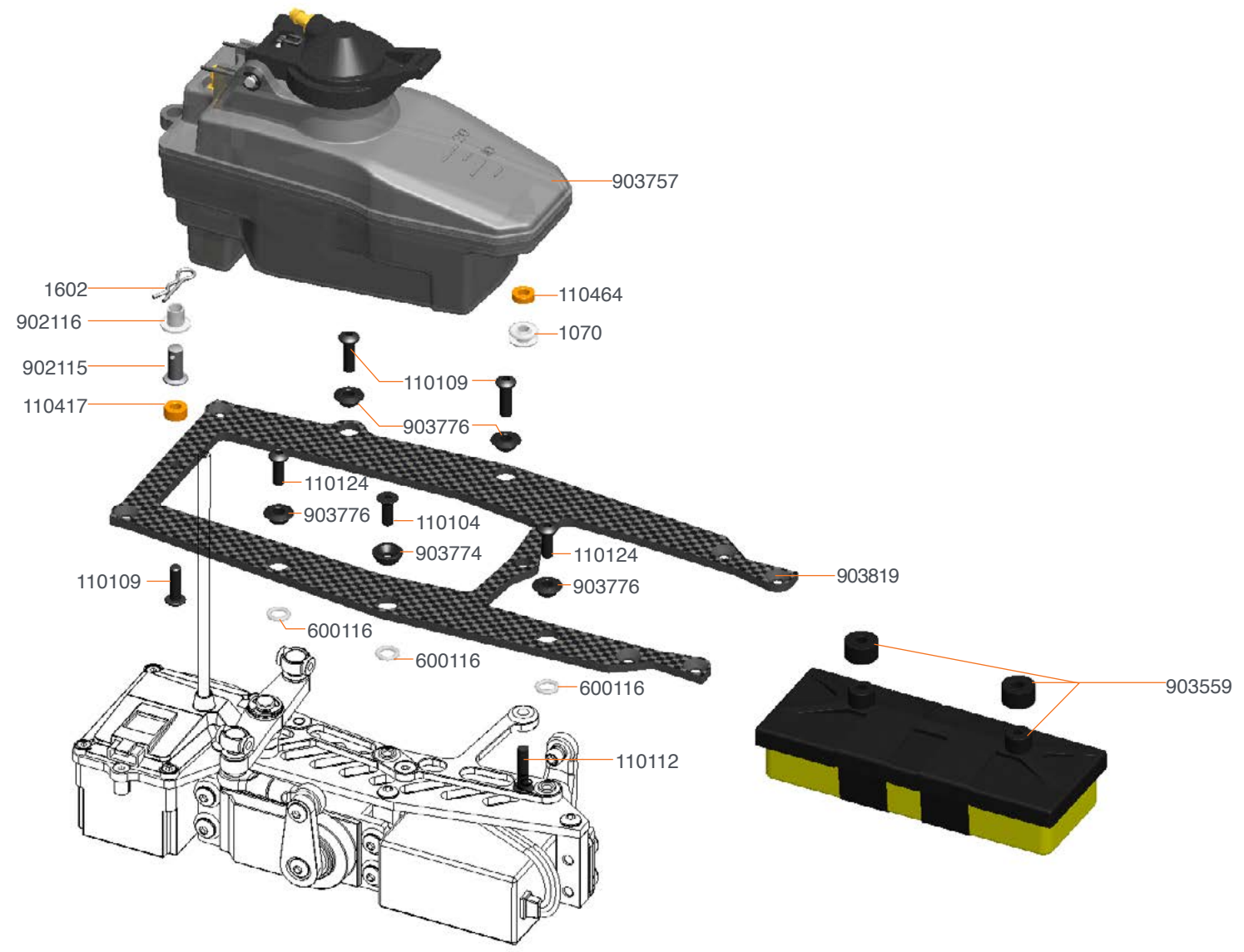

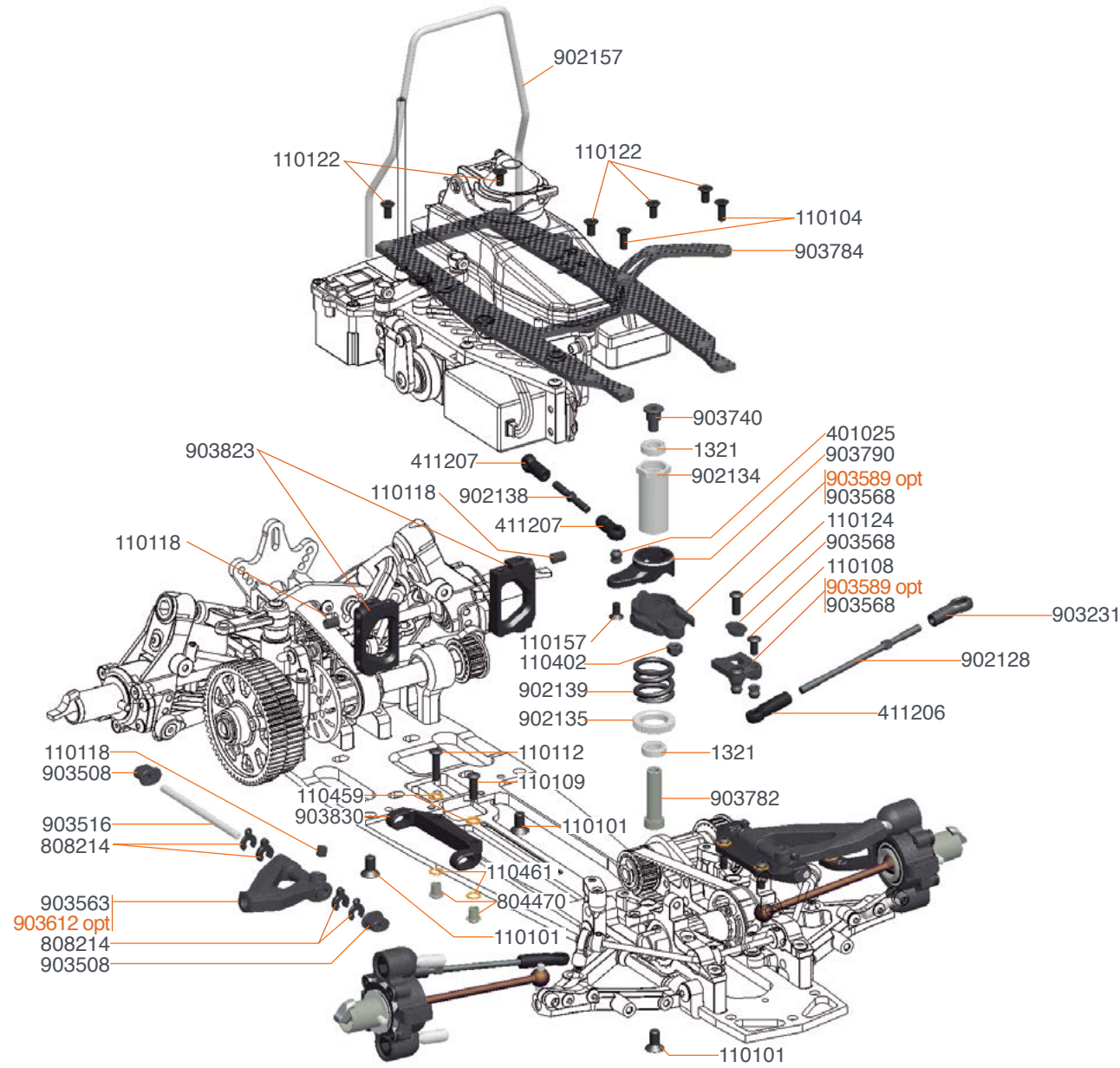

903589 Servosaver bottom alu (2)  
 903612 Wishbone FR up (2) hard





# BUMPER AND BODYMOUNT EXPLODED VIEW

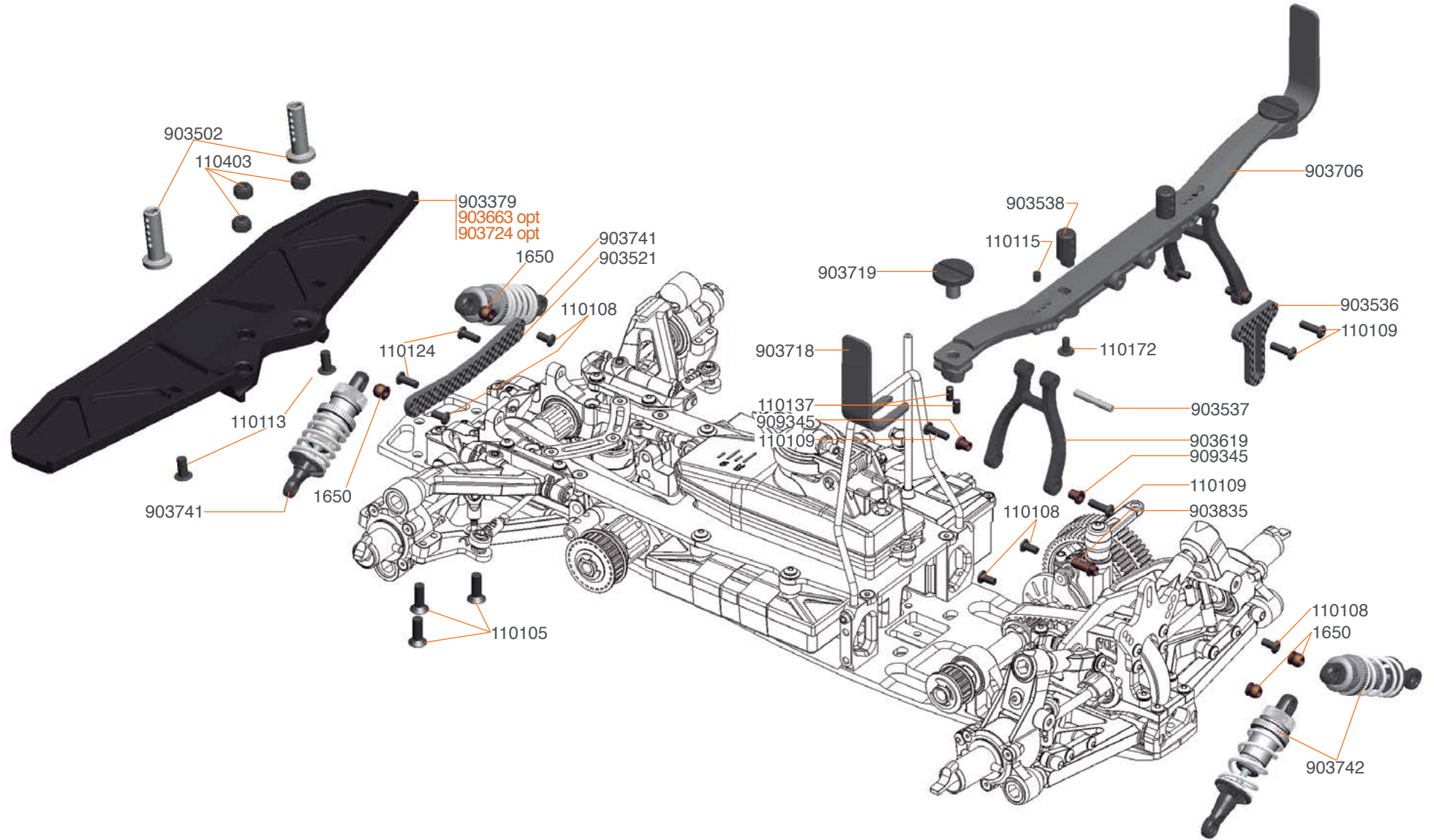

- 903663 Bumper 1/8 FLOW
- 903664 Bumper insert set (2+2) FLOW
- 903724 Bumper light S989

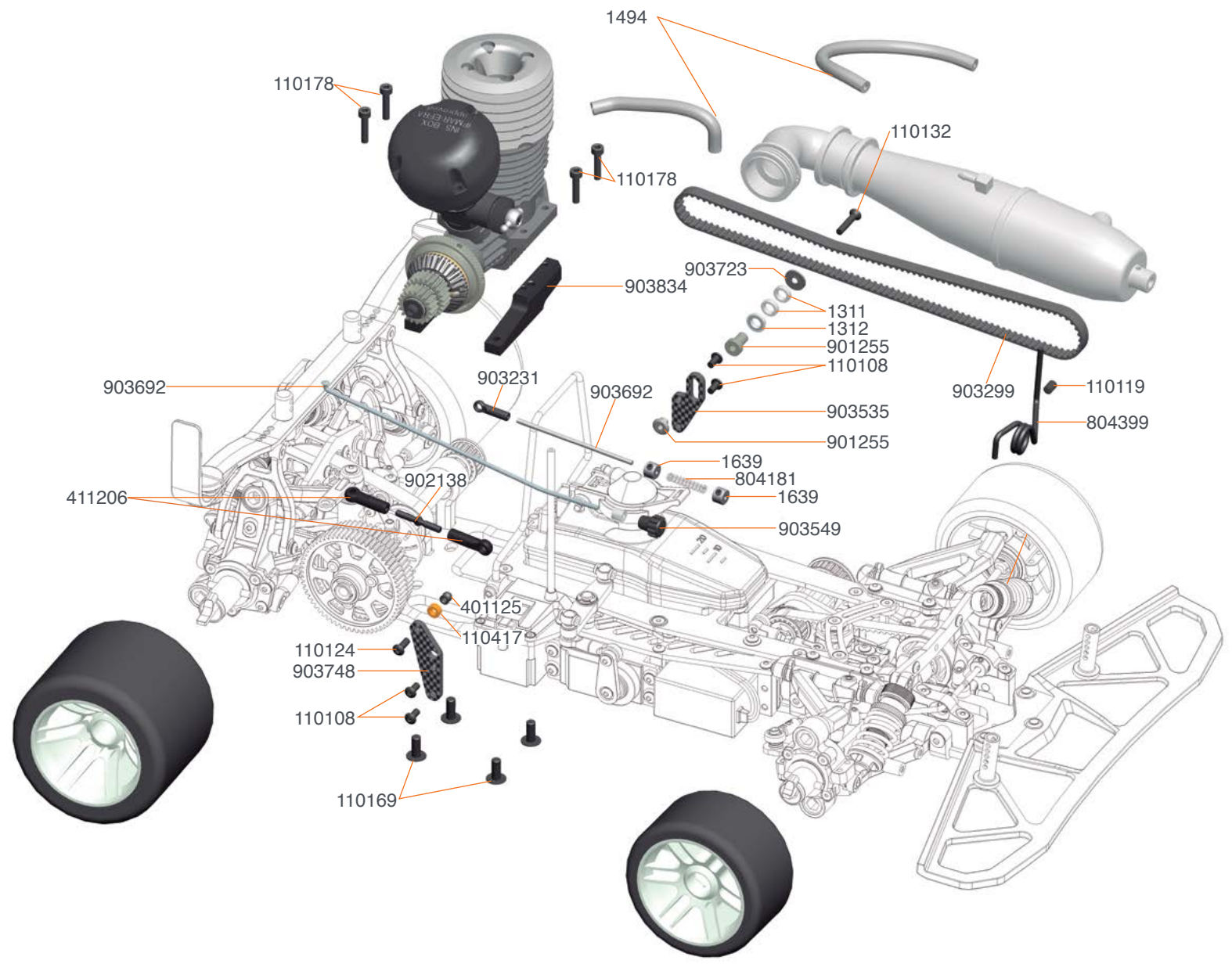

**NOTES:**

A series of horizontal dashed orange lines providing a space for notes.



# TEAM SERPENT NETWORK

**990 SPARE PARTS** [www.serpent.com/903020spares/](http://www.serpent.com/903020spares/)



**990 OPTIONALS PARTS** [www.serpent.com/903020/Optionals/](http://www.serpent.com/903020/Optionals/)



**SERPENT TOOLS** [www.serpent.com/product/Tools/](http://www.serpent.com/product/Tools/)



**SERPENT MERCHANDISING** [www.serpent.com/product/Merchandising/](http://www.serpent.com/product/Merchandising/)



## SERPENT WEBSITE AND BLOG

[www.serpent.com](http://www.serpent.com)

[www.teamserpent.com](http://www.teamserpent.com)

[www.dragon-rc.com](http://www.dragon-rc.com)

**SERPENT PROMO PAGES** <http://promo.serpent.com>

## SERPENT SOCIAL MEDIA



[www.facebook.com/SerpentMRC](http://www.facebook.com/SerpentMRC)



[www.youtube.com/user/SerpentMRC](http://www.youtube.com/user/SerpentMRC)



# VIPER 9900



Manual Viper 990 # 57677-1

**SERPENT**