

MTS TBM-V2

1:10 ELECTRONIC TOURING PRO CAR KIT
(MID MOTOR)

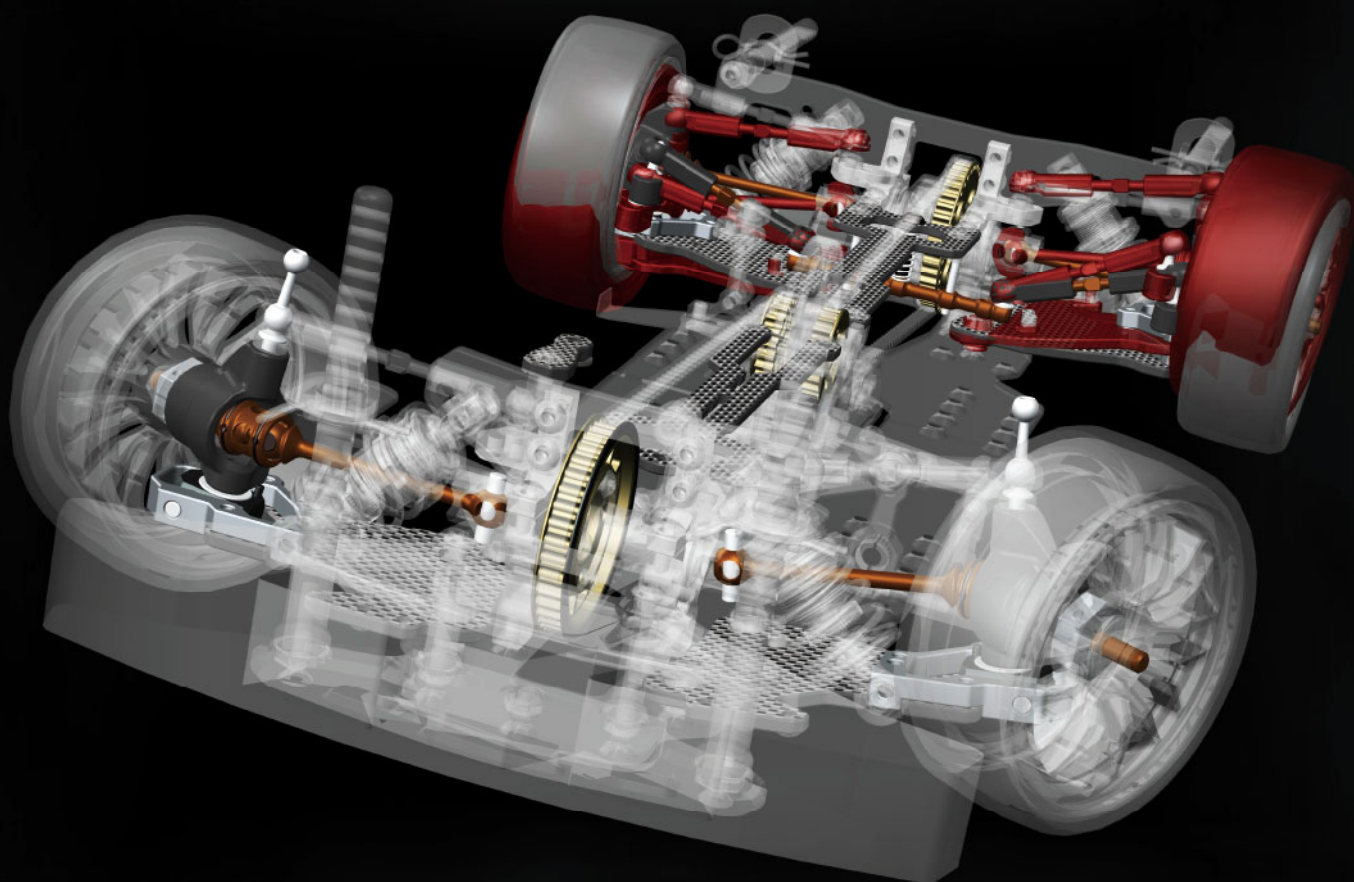

MADE IN CHINA

RACE UPT

SURFC

MTS T3M-V2

INTRODUCTION:

MTS T3M-V2 1:10 Central Drive Touring Car kit is a professional 1:10 4 wheel drive car and should be built by aged 14 years or over or that they had experience building and operating R/C model cars before. This is not a toy intended for use by beginners or by children without any supervision of a knowledgeable adult. Please read the instruction manual carefully before building.

Race Opt should not be liable for any loss, injury or damages, whether direct, indirect, special, incidental, consequential, arising from the use, misuse, abuse of this product or accessories required to operate this product.

WARNINGS:

- ⊙ This product is not intended for those ages under 14 year without any adult supervision.
- ⊙ Assemble this kit only in places away from the reach of children.
- ⊙ Pay attention to the safe use of tools and sharp tools, and pay attention to some parts with sharp edges when building vehicles.
- ⊙ Please do not touch any electronic equipment on the model such as motor and speed controller that having higher temperatures after the operation. Otherwise, it may burn yourself seriously by touching them. Better to allow 10 ~ 15 minutes to let any electronic equipment cool down.
- ⊙ Please complete a successful pre-run check of your radio equipment and model before the run. Make sure to keep the wheels of the model off the ground when checking the operation of the radio equipment.
- ⊙ When on the model, please always turn on the transmitter before turn on the receiver in the car. When off the model please always turn off the receiver before turn off the transmitter. Otherwise, the model may become uncontrollable and cause serious damage.
- ⊙ Disconnect the battery pack before storing your model.
- ⊙ Do not get overcharge for the battery or leave battery unattended while charging. Never let children charge the battery without adult supervision.
- ⊙ Do not operate it on public places, roads or areas where its operation can conflict with or disrupt pedestrian or vehicular traffic.
- ⊙ Do not use your model as shown below:

In places where children and people gather	In rain, wind snow or darkness condition
In areas where loud noises can disturb others	At anytime your line of sight to the model may be obstructed or Impaired In any way

MTS T3M-V2

Electrical Precautions:

- ⦿ Please do not allow any metal part to short circuit the battery or any electronic part using inside the car kit.
- ⦿ Never put batteries into fire.
- ⦿ Use the recommended charger for the transmitter battery and battery for electronic speed control.
Please follow the charging instructions carefully . Please do not over charge the battery or choose the wrong charging mode .
It becomes dangerous that causes the explosion and lead to the fire . If battery becomes extremely hot during the charging , please seek the advice from or get replacement from the corresponding battery supplier.
- ⦿ Please unplug charger when not in use.
- ⦿ When not using RC model , please always disconnect and remove the battery.
- ⦿ Low battery may result in loss of control . Please stop running the car at once when you find its speed start to slow down.
- ⦿ After use the battery , the battery remains heat and please recharges it after the battery is cool down.
- ⦿ Never use damaged wires that are dangerous and cause short circuits and may lead to the fire.

Other Equipment Needed (not included) :

Radio transmitter & receiver	Battery for transmitter
Electronic speed control	Steering Servo
540 Type brushes or brushless motor	Pinion Gear (48pitch/64pitch)
190mm body shell	7.4V Nimh or Lipo Battery
Touring Car Tire set	Battery charger

Tools Needed (not included):

1.5mm, 2.0mm, 2.5mm, 3.0mm allen wrench	5.0mm, 5.5mm, 7.0mm hex socket wrench
Modelers craft knife	Turnbuckle wrench
Calipers/Ruler	Camber gauge
Instant glue/Thread lock glue	Shock and Diff Oil
Thrust, Diff and Joint grease	Paint for body shell

Notes: All replacement parts can be found from www.race-opt.com/www.sn-rc.com and can be purchased from local hobby shop. If any further information needed, please email to enquiry@rc-explorer.com.

MTS T3M-V2

917258	943571	945111	960902	950210
M2.5x8	3.5x7x0.1	5x11x0.1	9x2	2x9.8

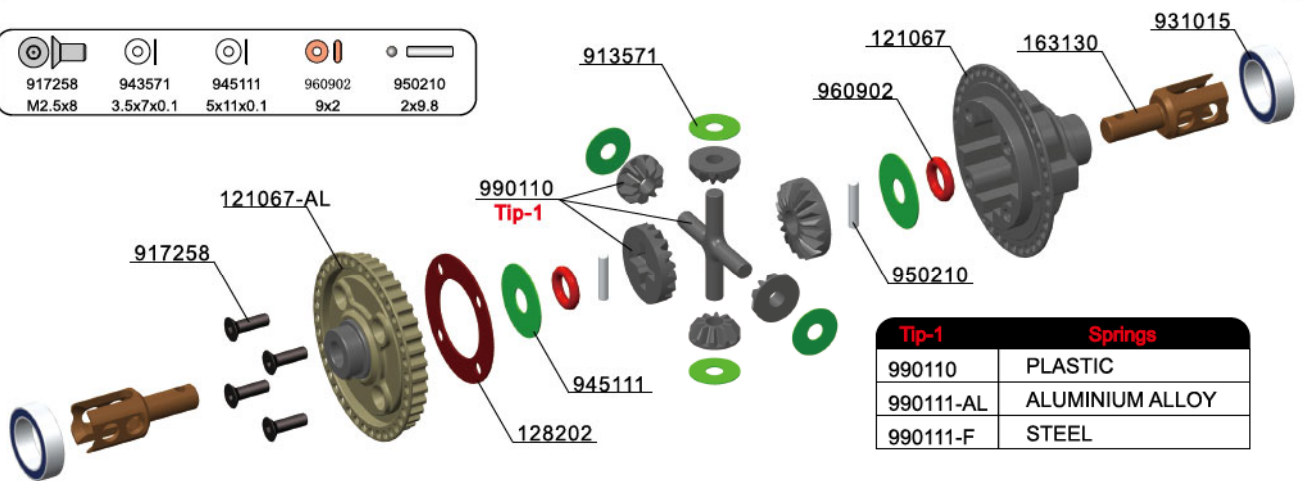

Tip-1	Springs
990110	PLASTIC
990111-AL	ALUMINIUM ALLOY
990111-F	STEEL

121063-AL ALU. FRONT BELT PULLEY (38T)
121067 COMPOSITE GEAR DIFF. CASE & COVE

163130 UNIVERSAL CVD DRIVE SHAFT-SPRING STEEL10x3.1 S2(2)
990110 PLANETARY GEAR SET-PLASTIC
128202 DIFF GASKET 26mm

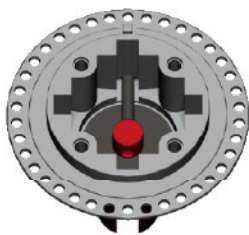

Low-Traction
1000# cst

High-Traction
10000# cst

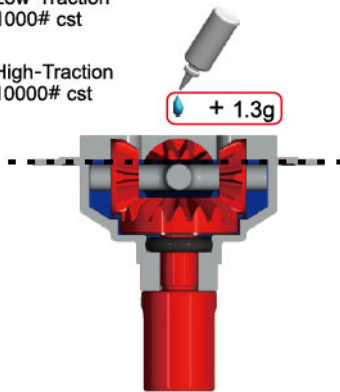

Add 1.3g of oil the diff.

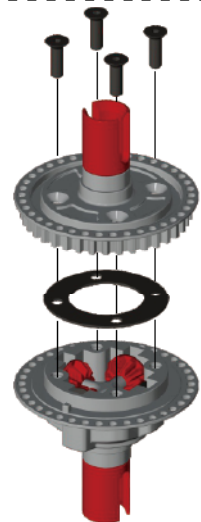
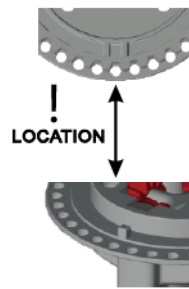

918304-GD	950212	930418	931015	940483
M3x4	2x12	4x8x3-F	10x15x4	4x8x0.3

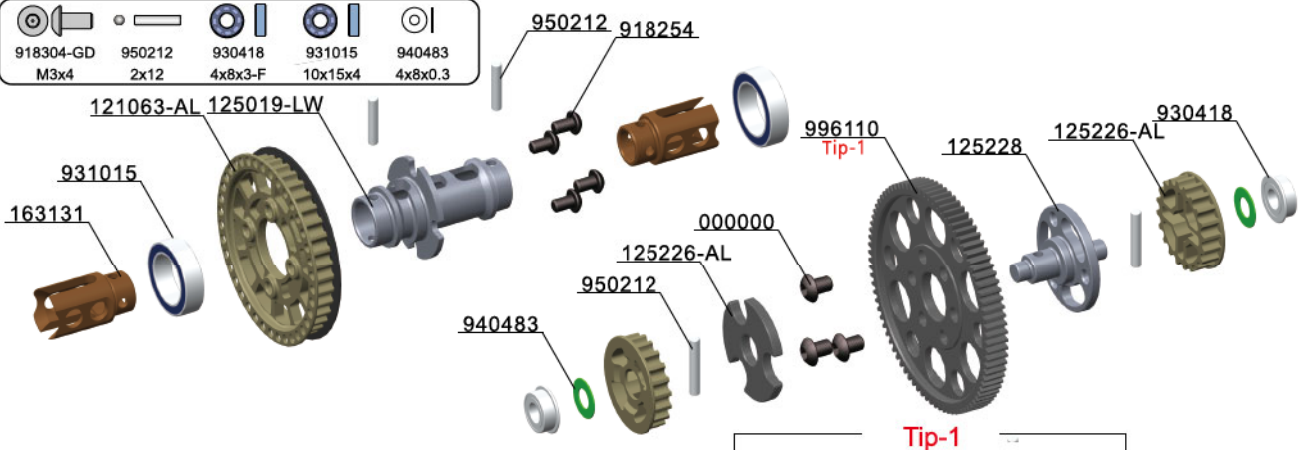

121067-AL ALU. FRONT BELT PULLEY (38T)
125226-AL 20T FIXED PULLEY (NARROW) AL
125019-LW LIGHT WEIGHT SUSPENSION MOUNT (RR)
125228 ALU. SOLID LAYSHAFT (NARROW) 4.0
163131 FRONT SOLID AXLE SPOOL OUTDRIVE
-SPRING STEEL10x7.5x3.1 S2
996110 SPUR GEAR 110T / 64P

48P	
994084	SPUR GEAR 84T/48P
994084-WH	SPUR GEAR 84T/48P
994087	SPUR GEAR 87T/48P
994087-WH	SPUR GEAR 87T/48P

64P	
996110	SPUR GEAR 110T/64P
996110-WH	SPUR GEAR 110T/64P
996116	SPUR GEAR 116T/64P
996116-WH	SPUR GEAR 116T/64P

MTS T3M-V2

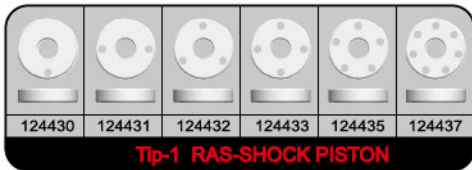

Tip-1 RAS-SHOCK PISTON

940025 C2.5	960615 6x1.5	961401 14x1

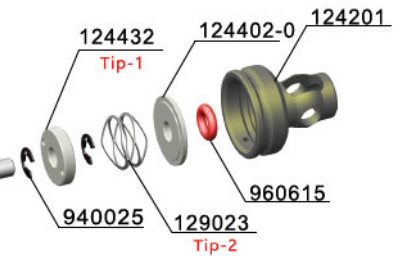

Tip-3 SPENSION SPRING

129140	1.4x17x4.0 RD 4.0KG
129145	1.4x17x4.5 SR 3.5KG
129150	1.4x17x5.0 YE 3.0KG
129155	1.4x17x5.5 BL 2.5KG

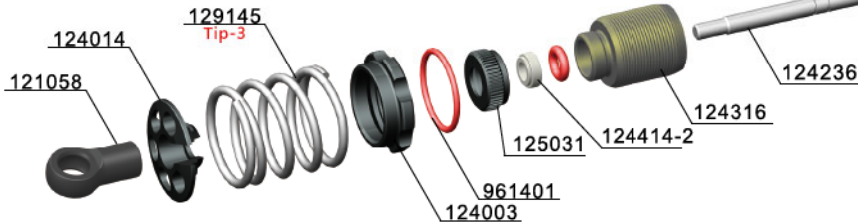

Tip-2 MULTI-LOBE COMPRESSION SPRING

129012	COMPRESSION SPRING	0.2x4x3x9.5
129013	COMPRESSION SPRING	0.3x4x3x9.5
129022	COMPRESSION SPRING	0.2x5x4x9.5
129023	COMPRESSION SPRING	0.3x5x4x9.5
129032	COMPRESSION SPRING	0.2x6.5x5x9.5
129033	COMPRESSION SPRING	0.3x6.5x5x9.5

- 124201 RAS- SHOCK CAP
- 124402-1 RAS-SHOCK TOP COVER 3x1.3
- 129013 MULTI-LOBE COMPRESSION SPRING 0.3x5x4x9.5
- 124433 RAS-SHOCK PISTON (3 HOLE)
- 124236 RAS-SHOCK SHAFT 3x36mm
- 124316 RAS-SHOCK BODY 12x16mm
- 124414-2 RAS-SHOCK V2 TOP COVER(3x2.2MM YELLOW)
- 125031 ALU SHOCK BOTTOM CAP(COMPLETE SET)M8x4.0
- 124003 SUSPENSION SPRING RETAINER-12mm
- 129145 1.4 x17x4.5 SUSPENSION SPRING SR 3.0KG
- 124014 ALU.SHOCK SPRING RETAINING COLLAR LOW GRAVITY - 3.0mm
- 121058 SHOCK BALL JOINT

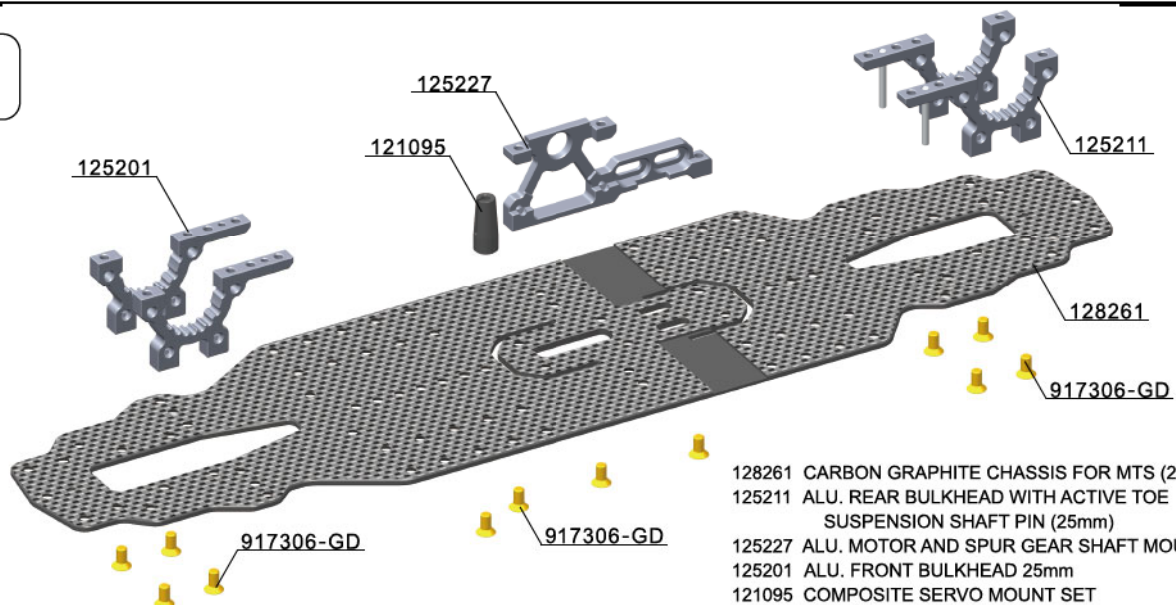
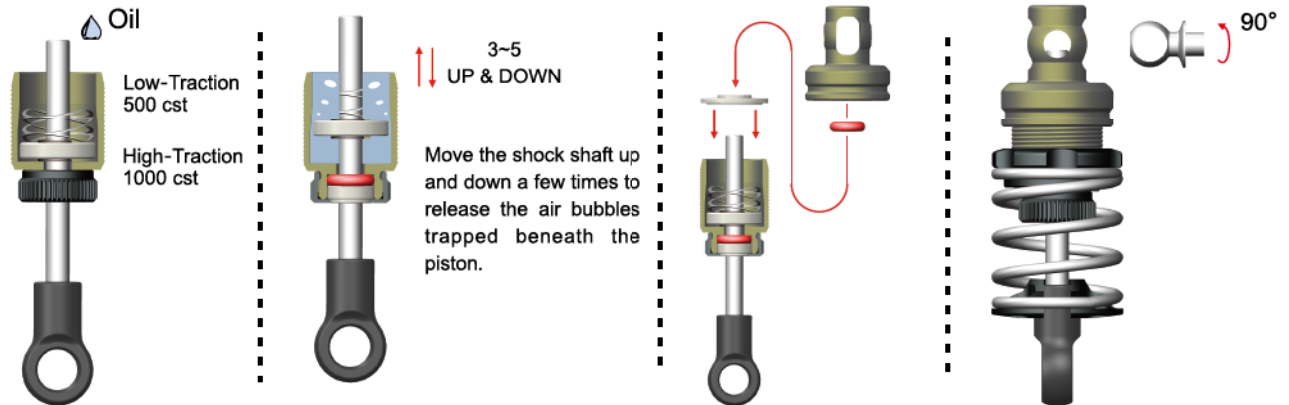

- 128261 CARBON GRAPHITE CHASSIS FOR MTS (2mm)
- 125211 ALU. REAR BULKHEAD WITH ACTIVE TOE SUSPENSION SHAFT PIN (25mm)
- 125227 ALU. MOTOR AND SPUR GEAR SHAFT MOUNT
- 125201 ALU. FRONT BULKHEAD 25mm
- 121095 COMPOSITE SERVO MOUNT SET

MTS T3M-V2

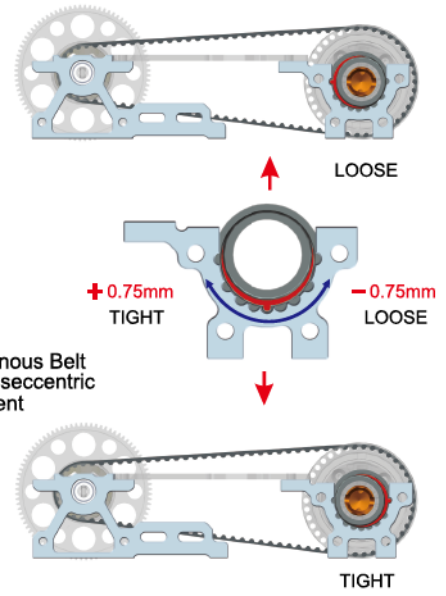
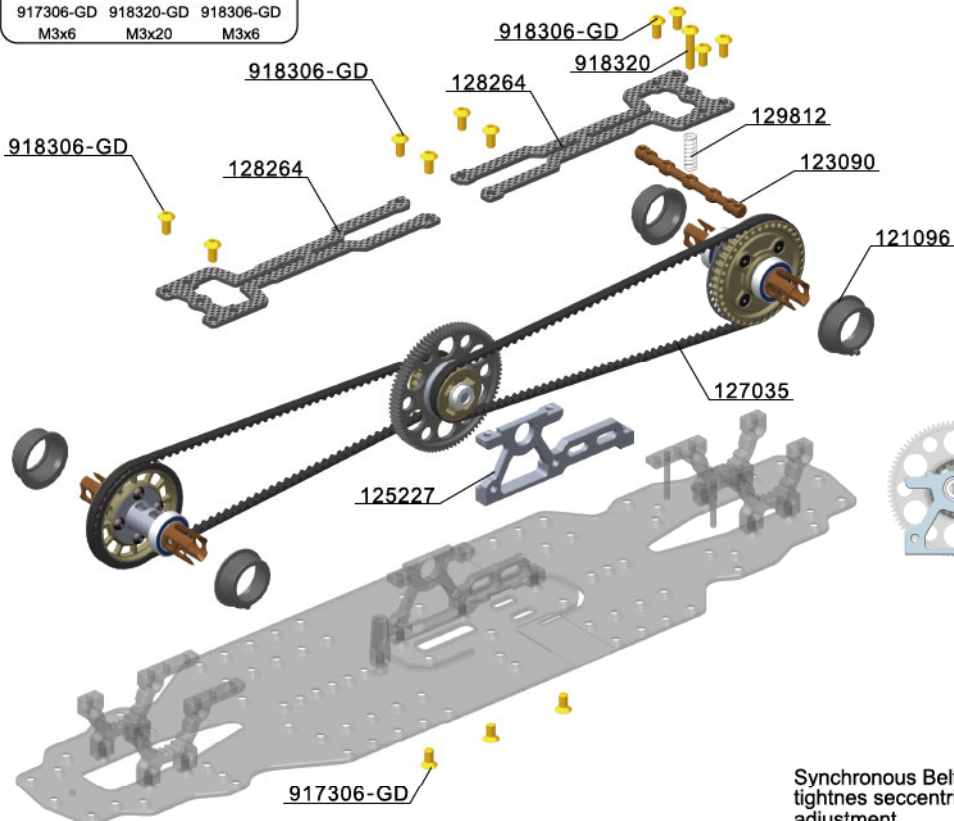

- 128264 CARBON GRAPHITE FRONT 2ND DESK FOR (2mm)
- 123090 ACTIVE TOE SUSPENSION HOLDER(S2)
- 129812 ACTIVE TOE SUSPENSION SPRING(5x0.7x12x8)
- 125227 ALU. MOTOR AND SPUR GEAR SHAFT MOUNT
- 121096 COMPOSITE ADJUSTMENT BALL-BEARING HUB
- 127035 SYNCHRONOUS BELT LENGTH-351 117T

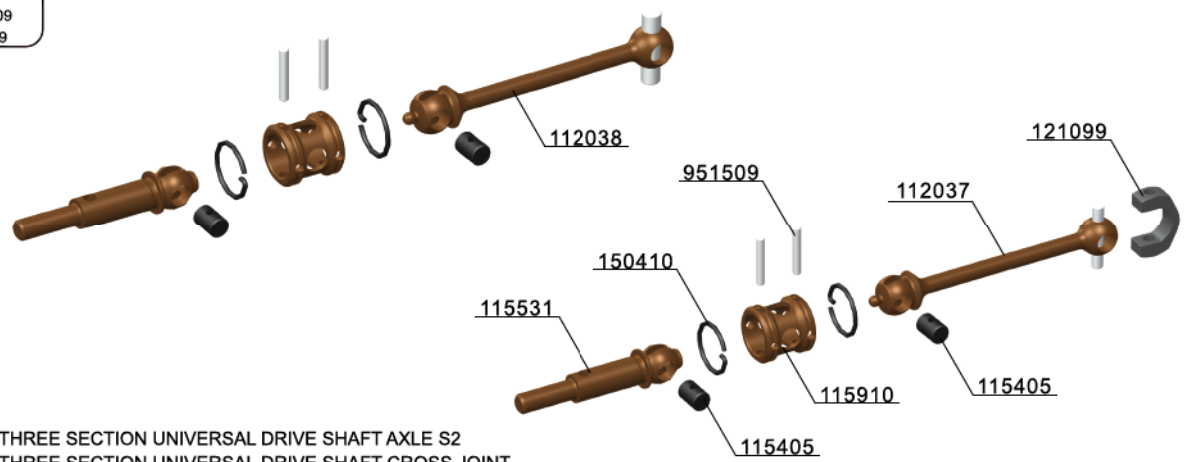

- 115531 THREE SECTION UNIVERSAL DRIVE SHAFT AXLE S2
- 115405 THREE SECTION UNIVERSAL DRIVE SHAFT CROSS JOINT
- 150410 THREE SECTION UNIVERSAL DRIVE SHAFT JOINT HOUSING C-CLIP
- 115910 THREE SECTION UNIVERSAL DRIVE SHAFT JOINT HOUSING S2
- 112037 38mm THREE SECTION UNIVERSAL DRIVE SHAFT(SPRING STEEL)- 2mm PIN
- 112038 38mm THREE SECTION UNIVERSAL DRIVE SHAFT(SPRING STEEL)- 3mm PIN
- 121099 DRIVE SHAFT REPLACEMENT PLASTIC CAP

MTS T3M-V2

930306	917314-GD	940362	916205
3x6x2.5	M3x14	3x6x2	M2x5

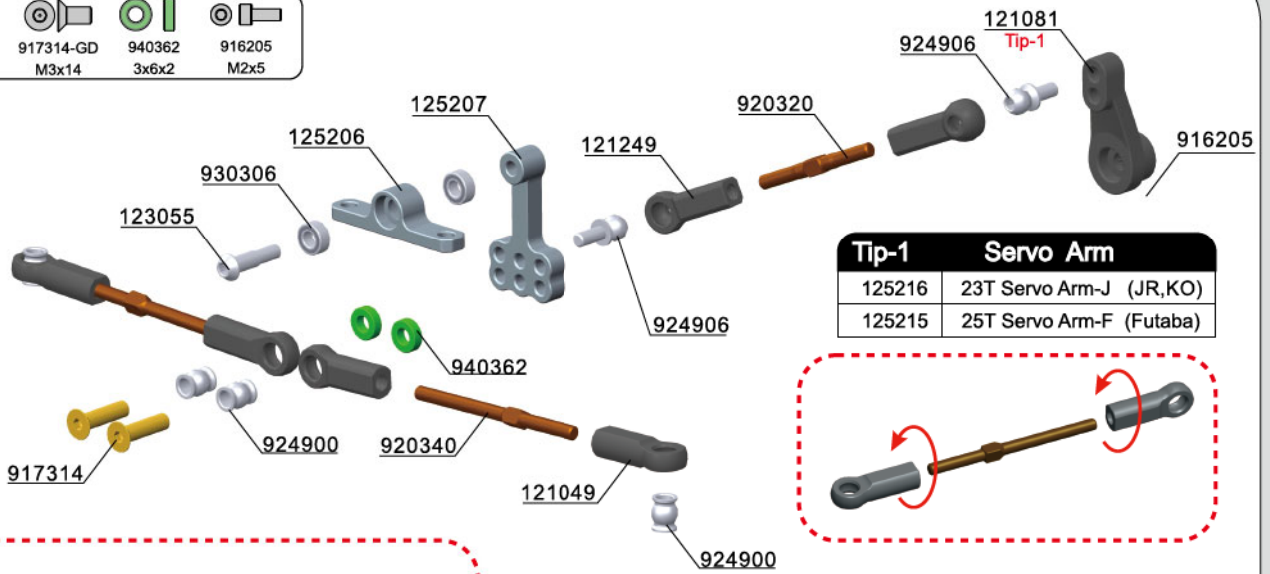

Tip-1 Servo Arm	
125216	23T Servo Arm-J (JR,KO)
125215	25T Servo Arm-F (Futaba)

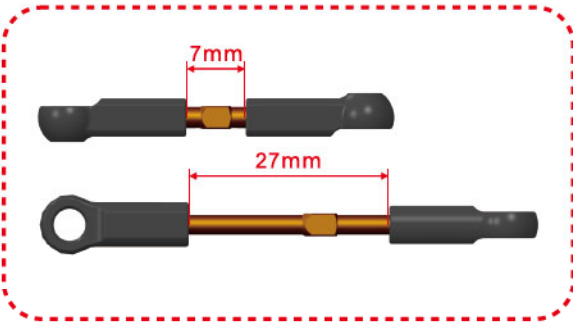
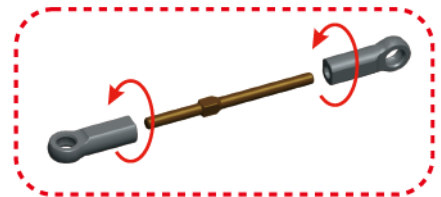

- 924900 PIVOT BALL 4.9x6mm DOUBLE BEVEL SHOULDERS
- 920320 ADJ. TURNBUCKLE L/R 20mm - SPRING STEEL
- 920340 ADJ. TURNBUCKLE L/R 40mm - SPRING STEEL
- 924906 BALL END 4.9mm WITH THREAD 6mm H2.0
- 123055 SPRING STEEL STEERING SHAFT
- 125206 ALU. STEERING MOUNT HOLDER
- 125207 ALU. STEERING PLATE
- 121249 COMPOSITE BALL JOINT 4.9mm - CLOSED WITH HOLE
- 121049 COMPOSITE BALL JOINT 4.9mm - OPEN
- 125215 ALU. SERVO ARM(25T)

918306-GD	918308-GD
M3x6	M3x8

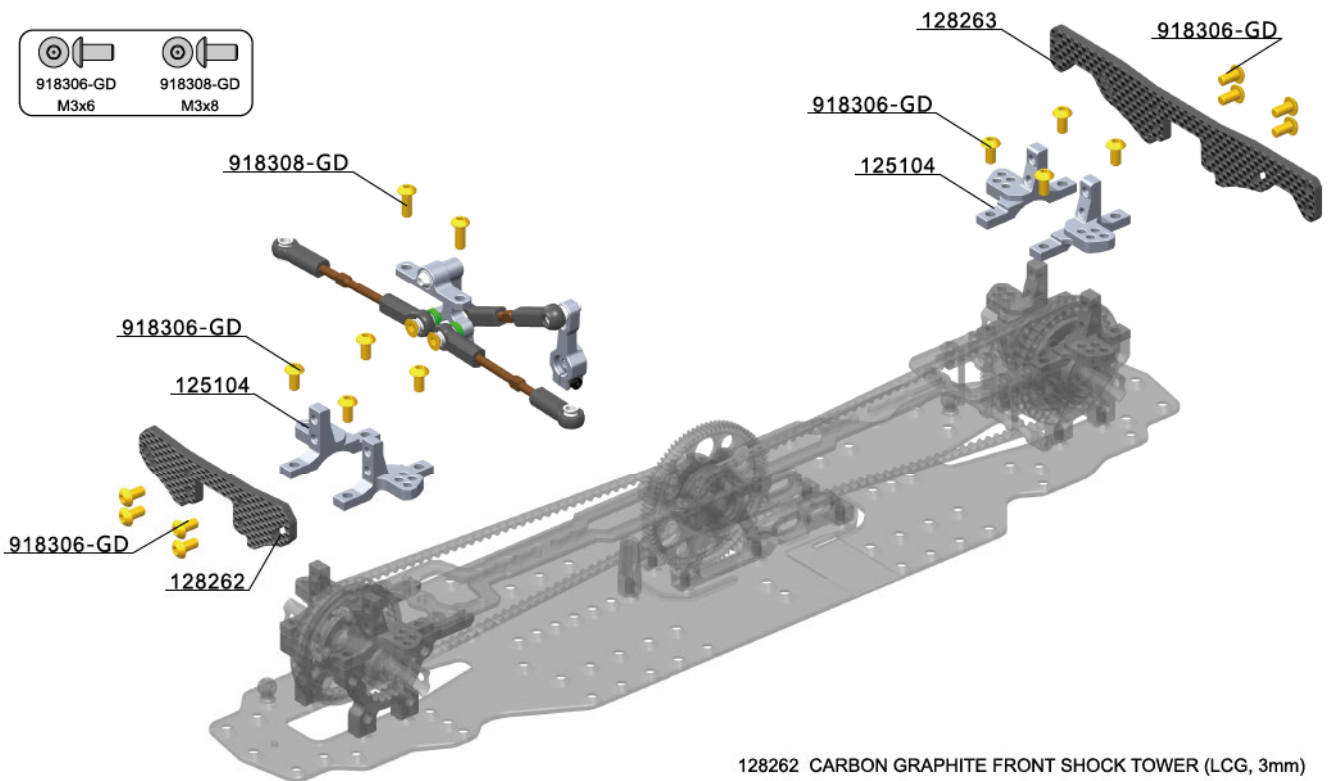

- 128262 CARBON GRAPHITE FRONT SHOCK TOWER (LCG, 3mm)
- 128263 CARBON GRAPHITE REAR SHOCK TOWER (LCG, 3mm)
- 125104 REAR BEARING SLEEVE CLAMP (L+R)

MTS T3M-V2

915303	915304	915310	917256-GD	917306-GD	917314-GD	918114	916205	919401	950210	950318	950320	940265	
M3x3	M3x4	M3x10	M2.5x6	M3x6	M3x14	M2.5x14	M2x5	M4	2x9.8	3x18	3x20	2.6x6	

940361	940362	930510	930518
3x6x1	3x6x2	5x10x4	5x8x2.5-F

- 123046 SUSPENSION ARM BALL JOINT HOLDER
- 123047 SUSPENSION ARM BALL JOINT HEX NUT M6.5
- 920324 ADJ. TURNBUCKLE L/R 24 mm - SPRING STEEL
- 920328 ADJ. TURNBUCKLE L/R 28 mm - SPRING STEEL
- 123048 BALL UNIVERSAL 5.9mm HEX (H3)
- 924959 DOUBLE BALL END 4.9 WITHTHREAD (BODY SUPPORTER)

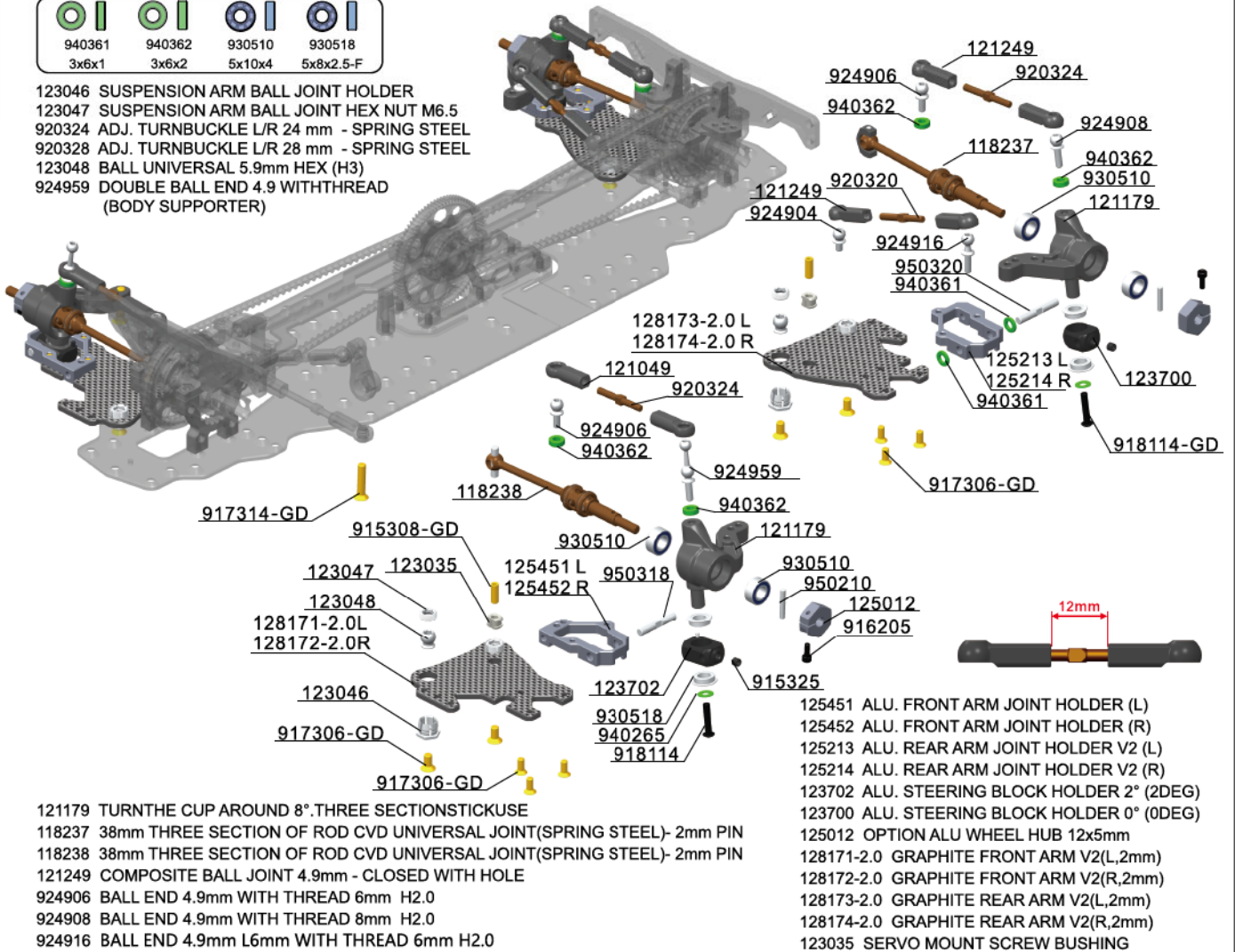

- 121179 TURN THE CUP AROUND 8°. THREE SECTION STICK USE
- 118237 38mm THREE SECTION OF ROD CVD UNIVERSAL JOINT (SPRING STEEL)- 2mm PIN
- 118238 38mm THREE SECTION OF ROD CVD UNIVERSAL JOINT (SPRING STEEL)- 2mm PIN
- 121249 COMPOSITE BALL JOINT 4.9mm - CLOSED WITH HOLE
- 924906 BALL END 4.9mm WITH THREAD 6mm H2.0
- 924908 BALL END 4.9mm WITH THREAD 8mm H2.0
- 924916 BALL END 4.9mm L6mm WITH THREAD 6mm H2.0
- 125451 ALU. FRONT ARM JOINT HOLDER (L)
- 125452 ALU. FRONT ARM JOINT HOLDER (R)
- 125213 ALU. REAR ARM JOINT HOLDER V2 (L)
- 125214 ALU. REAR ARM JOINT HOLDER V2 (R)
- 123702 ALU. STEERING BLOCK HOLDER 2° (2DEG)
- 123700 ALU. STEERING BLOCK HOLDER 0° (0DEG)
- 125012 OPTION ALU WHEEL HUB 12x5mm
- 128171-2.0 GRAPHITE FRONT ARM V2(L,2mm)
- 128172-2.0 GRAPHITE FRONT ARM V2(R,2mm)
- 128173-2.0 GRAPHITE REAR ARM V2(L,2mm)
- 128174-2.0 GRAPHITE REAR ARM V2(R,2mm)
- 123035 SERVO MOUNT SCREW BUSHING

947262	915308	917256-GD	918256-GD
2.5x6x2	M3x8	M2.5x6	M2.5x6

	Tip-1	Tip-2
123142	1.2 mm	1.2 mm
123143	1.3 mm	1.3 mm
123144	1.4 mm	1.4 mm
123146	1.6 mm	1.6 mm

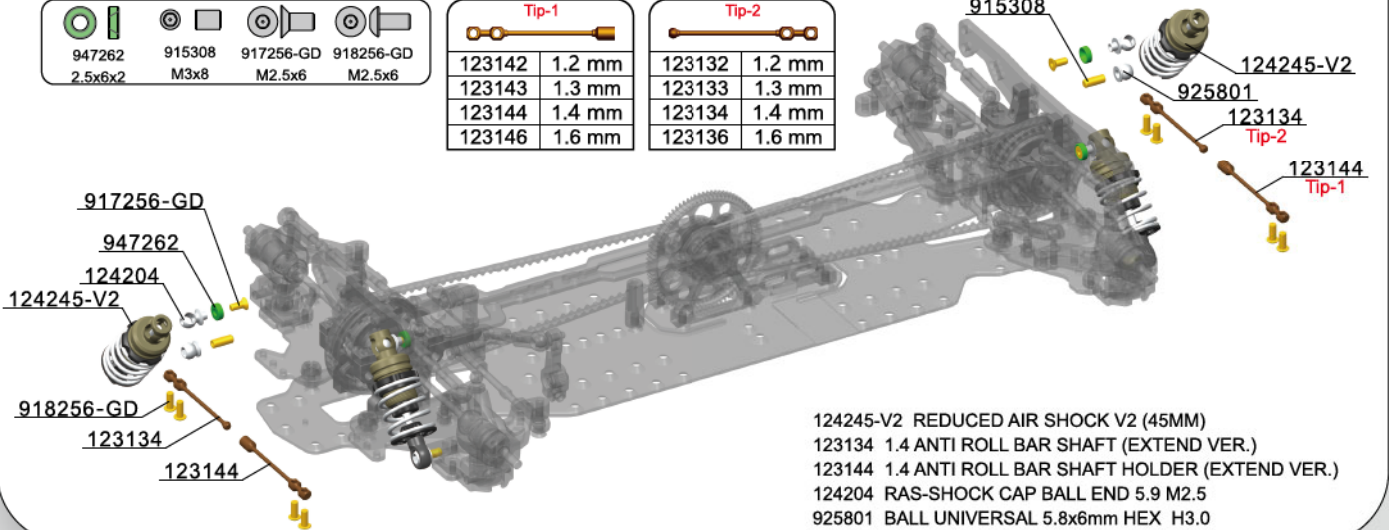

MTS T3M-V2

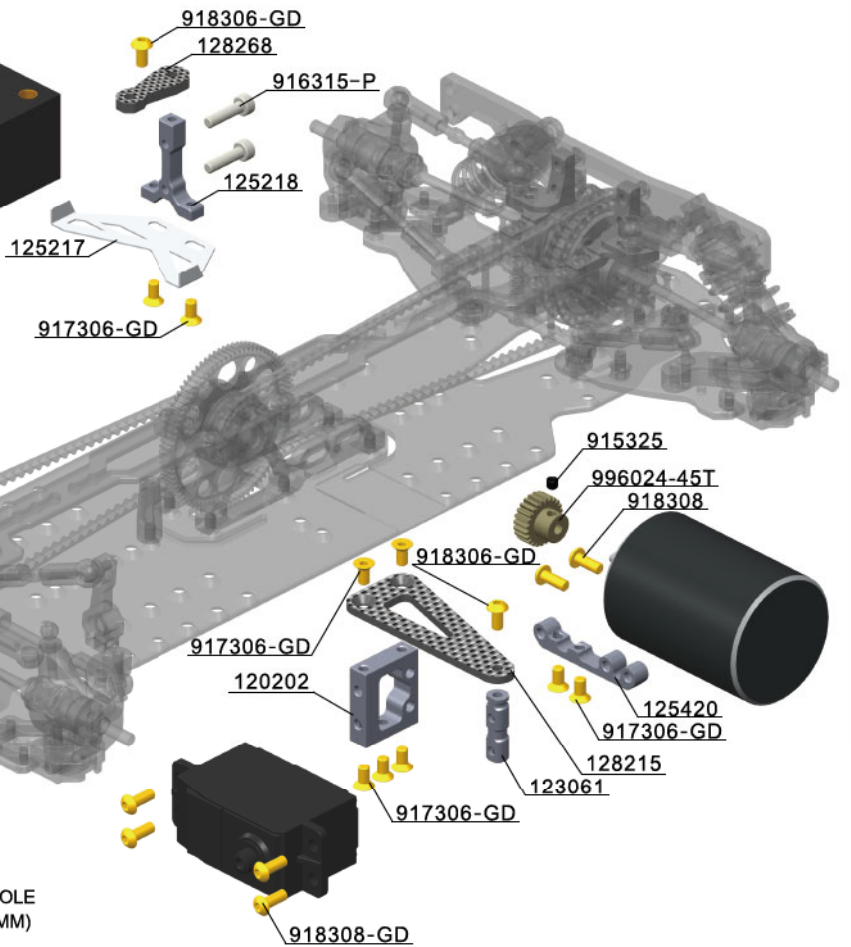
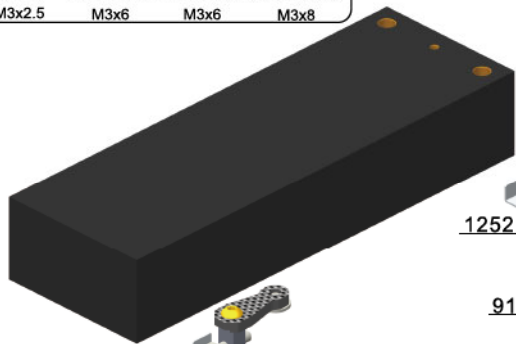
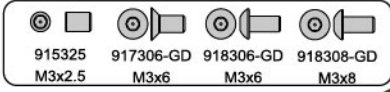

- 128215 GRAPHITE FLOATING SERVO MOUNT 2.0mm
- 123061 FLOATING SERVO COLUMN 2 HOLE
- 125420 30-40mm FAN MOUNT
- 120202 SUSPEENSION RUDDER FRAME-STRAIGHT 3 HOLE
- 128268 CARBON GRAPHITE BATTERY ARM HOLDER (3MM)
- 125218 ALU. BATTERY MOUNT HOLDER (V2)

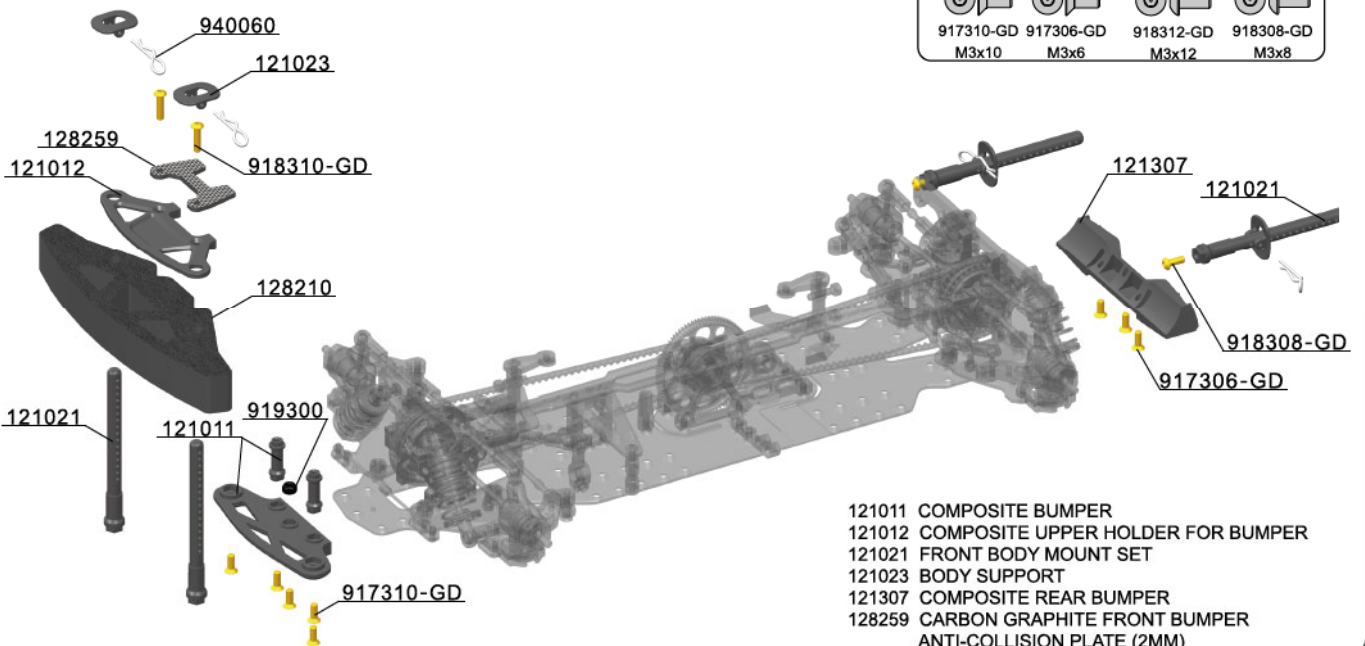

- 121011 COMPOSITE BUMPER
- 121012 COMPOSITE UPPER HOLDER FOR BUMPER
- 121021 FRONT BODY MOUNT SET
- 121023 BODY SUPPORT
- 121307 COMPOSITE REAR BUMPER
- 128259 CARBON GRAPHITE FRONT BUMPER
- ANTI-COLLISION PLATE (2MM)
- 940060 BODY CLIP 6mm

MTS T3M-V2

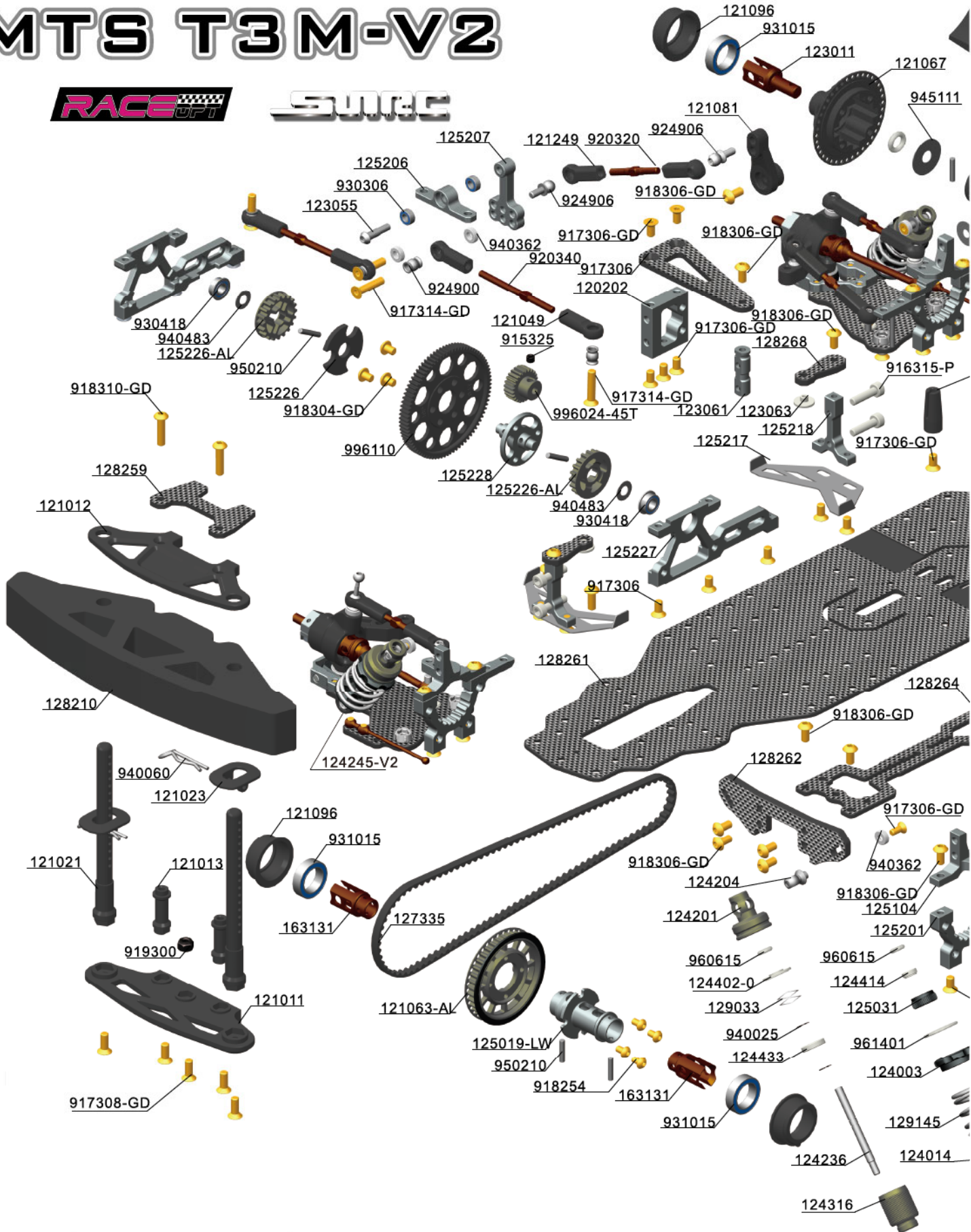

STANDARD	124014 ALU -3mm		123704 H10 4°		990110 PLASTIC		121081 25T PA	
OPTION PART								
	124012 ALU	124013 ALU -1mm	123702 H10 2°	123706 H10 6°	990110-AL ALU	990110-F STEEL	125215 25T ALU	125216 23T ALU

1/10 ELECTRIC TOURING CAR

MTS T3M-V2

<p>118238 38mm 118240 40mm</p>  <p>S2 3.0PIN</p> <p>THREE SECTION OF ROD CVD UNIVERSAL JOINT-S2</p>	<p>118237 38mm 118239 40mm</p>  <p>S2 2.0PIN</p> <p>THREE SECTION OF ROD CVD UNIVERSAL JOINT-S2</p>	<p>115531</p>  <p>S2</p> <p>DRIVE SHAFT AXLE (SPRING STEEL)</p>	<p>115910</p>  <p>S2</p> <p>DRIVE SHAFT JOINT HOUSING -SPRING STEEL</p>
<p>115405</p>  <p>DRIVE SHAFT CROSS JOINT</p>	<p>150410</p>  <p>DRIVE SHAFT JOINT HOUSING C-CLIP</p>	<p>112038 38mm 112040 40mm</p>  <p>S2 3.0PIN</p> <p>THREE SECTION UNIVERSAL DRIVE SHAFT-SPRING STEEL</p>	<p>112037 38mm 112039 40mm</p>  <p>S2 2.0PIN</p> <p>THREE SECTION UNIVERSAL DRIVE SHAFT-SPRING STEEL</p>
<p>124245-V2 12x45mm 124249-V2 12x49mm 124257-V2 12x57mm</p>  <p>MULTISTAGE REDUCED AIR SHOCKER-V2</p>	<p>160345</p>  <p>13x46mm</p> <p>SHORTER SHOCK ABSORBER 13x46mm</p>	<p>124201</p>  <p>ALU</p> <p>ALU RAS- SHOCK CAP</p>	<p>124402-0 3*1.3 BL 124402-1 3*1.4 YE 124402-2 3*1.5 WH</p>  <p>RAS-SHOCK V2 TOP COVER</p>
<p>124236 3x36mm 124239 3x40mm 124247 3x48mm</p>  <p>3.0mm</p> <p>RAS-SHOCK SHAFT</p>	<p>124316 12x16mm 124318 12x18mm 124322 12x22mm</p>  <p>ALU</p> <p>ALU-RAS-SHOCK BODY</p>	<p>124003</p>  <p>ALU 12mm</p> <p>ALU-SUSPENSION SPRING RETAINER-12mm</p>	<p>124414-0 3.0x2.0mm BL 124414-1 3.0x2.1mm YE 124414-2 3.0x2.2mm WH</p>  <p>RAS-SHOCK V2 TOP COVER</p>
<p>125031</p>  <p>M8x4.0mm</p> <p>ALU SHOCK BOTTOM CAP (COMPLETE SET)</p>	<p>120055</p>  <p>3.0x4mm</p> <p>UITRASHORT BOTTOM CAP SET WITH ORING</p>	<p>121058</p>  <p>5.8x15.5mm</p> <p>SHOCK BALL JOINT 5.8x15.5mm</p>	<p>129012 0.2x4x3x9.5 129013 0.3x4x3x9.5</p>  <p>4x3x9.5</p> <p>MULTI-LOBE COMPRESSION SPRING</p>
<p>129022 0.2x5x4x9.5 129023 0.3x5x4x9.5</p>  <p>5x4x9.5</p> <p>MULTI-LOBE COMPRESSION SPRING</p>	<p>129032 0.2x6.5x5x9.5 129033 0.3x6.5x5x9.5</p>  <p>6.5x5x9.5</p> <p>MULTI-LOBE COMPRESSION SPRING</p>	<p>129042 0.2x7.5x6x9.5 129043 0.3x7.5x6x9.5</p>  <p>7.5x6x9.5</p> <p>MULTI-LOBE COMPRESSION SPRING</p>	<p>129052 0.2x9x7x9.5 129053 0.3x9x7x9.5</p>  <p>9x7x9.5</p> <p>MULTI-LOBE COMPRESSION SPRING</p>

1/10 ELECTRIC TOURING CAR

MTS T3M-V2

<p>120061 High smoothness BL 120062 Moderate smoothness YE 120063 Low smoothness WH</p>  <p>RAS-SHOCK TOP COVER & RAS-SHOCK TOP COVER COLLAR</p>	<p>124430 (0 HOLE) 124431 (1 HOLE) 124432 (2 HOLE) 124433 (3 HOLE) 124435 (5 HOLE) 124437 (7 HOLE)</p>  <p>RAS-SHOCK PISTON</p>	<p>129140 1.4x17x4.0 RD 4.0kg 129145 1.4x17x4.5 SR 3.5kg 129150 1.4x17x5.0 YE 3.0kg 129155 1.4x17x5.5 BL 2.5kg</p>  <p>SUSPENSION SPRING 1.4x17mm</p>	<p>129345 1.4x19x4.5 RD 4.0kg 129350 1.4x19x5.0 SR 3.5kg 129355 1.4x19x5.5 YE 3.0kg 129360 1.4x19x6.0 BL 2.5kg</p>  <p>SUSPENSION SPRING 1.4x19mm</p>
<p>129450 1.4x21x5.0 RD 3.5kg 129455 1.4x21x5.5 SR 3.0kg 129460 1.4x21x6.0 YE 2.5kg 129465 1.4x21x6.5 BL 2.0kg</p>  <p>SUSPENSION SPRING 1.4x21mm</p>	<p>129550 1.5x21x5.0 RD 4.5kg 129555 1.5x21x5.5 SR 4.0kg 129560 1.5x21x6.0 YE 3.5kg 129565 1.5x21x6.5 BL 3.0kg</p>  <p>SUSPENSION SPRING 1.5x21mm</p>	<p>124012</p>  <p>ALU ALU SHOCK SPRING RETAINING COLLAR</p>	<p>124013 -1mm 124014 -3mm</p>  <p>ALU ALU SHOCK SPRING RETAINING COLLAR</p>
<p>124204</p>  <p>5.9 M2.5mm RAS-SHOCK CAP BALL END 5.9 M2.5mm</p>	<p>124211 5.9x7mm 124311 5.9x10mm 124411 5.9x12mm</p>  <p>5.9mm RAS-SHOCK CAP BALL END SCREW 5.9mm</p>	<p>124501</p>  <p>ALU RAS-SHOCK HOLDER TOOL</p>	<p>121011</p>  <p>COMPOSITE BUMPER</p>
<p>121013</p>  <p>FRONT ANTI-COLLISION INNER STRUT</p>	<p>121012</p>  <p>COMPOSITE UPPER HOLDER FOR BUMPER</p>	<p>121021</p>  <p>FRONT BODY MOUNT SET</p>	<p>161022 60mm 161024 71mm</p>  <p>71mm REAR BODY MOUNT SET 71mm LENGHT</p>
<p>121023</p>  <p>BODY SUPPORT</p>	<p>121049</p>  <p>4.9mm COMPOSITE BALL JOINT 4.9mm - OPEN</p>	<p>121249</p>  <p>4.9mm COMPOSITE BALL JOINT 4.9mm - CLOSED WITH HOLE</p>	<p>121067</p>  <p>38T COMPOSITE GEAR DIFF. CASE & COVER 38T</p>
<p>121081</p>  <p>COMPOSITE SERVO HORN</p>	<p>121095</p>  <p>COMPOSITE SERVO MOUNT SET</p>	<p>121096</p>  <p>COMPOSITE ADJUSTMENT BALL-BEARING HUB</p>	<p>121099</p>  <p>2.0PIN DRIVE SHAFT REPLACEMENT PLASTIC CAP</p>

1/10 ELECTRIC TOURING CAR

MTS T3M-V2

121307 	121179  8°	121114  S2 CUP 3.6	121113 ALU  S2 CUP 3.6
COMPOSITE REAR BUMPER	TURNTHE CUP AROUND 8° THREE SECTION STICKUS	GEAR DIFFERENTIAL - PLASTIC SET S2 CUP 3.6	GEAR DIFFERENTIAL - SET -ALU GEAR S2 CUP 3.6
121113-F  S2 CUP 3.6	161112 ALU  S2 CUP 3.1	161113  S2 CUP 3.1	161112-F  S2 CUP 3.1
GEAR DIFFERENTIAL - SET -ALU GEAR S2 CUP 3.6	GEAR DIFFERENTIAL - SET -ALU GEAR S2 CUP 3.1	GEAR DIFFERENTIAL - PLASTIC SET 3.1	GEAR DIFFERENTIAL - SET -STEEL GEAR S2 CUP 3.1
990110 	990110-AL  ALU	990110-F  STEEL	163130 3.1 123011 3.6  S2
PLANETARY GEAR SET-PLASTIC	PLANETARY GEAR SET-HARD COATED-ALU	PLANETARY GEAR SET-STEEL	UNIVERSAL CVD DRIVE SHAFT - 10x3.6 S2
163031 3.1mm 163036 3.6mm  S2	160031-LW 3.1mm 160036-LW 3.6mm  S2	122098  3.5x23mm	120200 
FRONT SOLID AXLE SET 10x7.5 S2	FRONT SOLID AXLE SET 10x7.5 S2	DIFF CROSS SHAFT 3.5mm	OPTIONAL FLOATING SERVO MOUNT (2HOLE)
120202  3 HOLE	123061  2 HOLE	123005  ALU	123031  ALU 25mm
SUSPENSION RUDDER FRAME-STRAIGHT	FLOATING SERVO COLUMN	BELT TENSIONER SET	ALU.CHASIS BRACE
123047  M6.5 H4.0	123048  5.8mm L4 H3.0	123055 	123046 2.0 123046-2.5  2.0/2.5mm
SUSPENSION ARM BALL JOINT HEX NUT M6.5	BALL UNIVERSAL 5.8mm HEX	SPRING STEEL STEERING SHAFT	SUSPENSION ARM BALL JOINT HOLDER

1/10 ELECTRIC TOURING CAR

MTS T3M-V2

<p>123035</p>  <p>SERVO MOUNT SCREW BUSHING</p>	<p>123063</p>  <p>2.0mm</p> <p>BATTERY PRESSURE SHIM POM 23.5H BATTERIES</p>	<p>123089</p>  <p>ALU</p> <p>REAR BODY MOUNT SET -ALU</p>	<p>123090</p>  <p>S2</p> <p>ACTIVE TOE SUSPENSION HOLDER</p>
<p>123132 1.2 123133 1.3 123134 1.4 123136 1.6</p>  <p>ANTI ROLL BAR SHAFT (EXTEND VER.)</p>	<p>123142 1.2 123143 1.3 123144 1.4 123146 1.6</p>  <p>ANTI ROLL BAR SHAFT HOLDER (EXTEND VER.)</p>	<p>123224</p>  <p>1.2/1.3/1.4/1.6</p> <p>LENGTHEN ANTI ROLL BAR MALE & FEMALE SHAFT</p>	<p>123700</p>  <p>0°</p> <p>STEERING BLOCK HOLDER</p>
<p>123702 2DEG 123704 4DEG 123706 6DEG</p>  <p>ALU</p> <p>STEERING BLOCK HOLDER</p>	<p>123890</p>  <p>S2 3.0PIN</p> <p>STEERING WITH CVD UNIVERSAL JOINT</p>	<p>123891</p>  <p>S2 3.0PIN</p> <p>STEERING WITH CVD UNIVERSAL JOINT WHEEL HUB</p>	<p>123892 2.0mm 123893 2.5mm</p>  <p>ADAPTIVE REAR TOE SUSPENSION ASSEMBLY</p>
<p>121063-AL</p>  <p>38T ALU</p> <p>ALU. FRONT BELT PULLEY</p>	<p>121067-AL</p>  <p>38T ALU</p> <p>ALU. GEAR DIFF. CASE PULLEY</p>	<p>125012 H12x5mm 125012-1 H12x5+1mm 125012-2 H12x5+2mm 125012-3 H12x5+3mm 125012-4 H12x5+4mm</p>  <p>ALU H12</p> <p>OPTION ALU WHEEL HUB</p>	
<p>125019-LW</p>  <p>ALU</p> <p>ALU. LIGHT WEIGHT FRONT SOLID AXLE</p>	<p>125104</p>  <p>ALU L+R</p> <p>REAR BEARING SLEEVE CLAMP</p>	<p>125201</p>  <p>25mm</p> <p>ALU. FRONT BULKHEAD</p>	<p>125206</p>  <p>ALU</p> <p>ALU. STEERING MOUNT HOLDER</p>
<p>125207</p>  <p>ALU</p> <p>ALU. STEERING PLATE</p>	<p>125211</p>  <p>25mm</p> <p>ALU. REAR BULKHEAD WITH ACTIVE TOE SUSPENSION</p>	<p>125215 25T 1252</p>  <p>ALU. SERVO ARM</p>	<p>125218</p>  <p>ALU</p> <p>ALU. BATTERY MOUNT HOLDER(V2)</p>













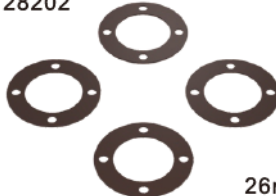

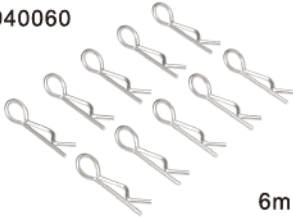
1/10 ELECTRIC TOURING CAR

MTS T3M-V2

<p>125417-LW 30mm 125418-LW 40mm</p>  <p>40mm LW</p> <p>FAN MOUNT 40mm LIGHTWEIGHT</p>	<p>125420</p>  <p>30/40mm</p> <p>30-40mm FAN MOUNT</p>	<p>125213</p>  <p>V2 RL</p> <p>ALU. ADAPTIVE REAR TOE SUSPENSION JOINT HOLDER</p>	<p>125214</p>  <p>V2 RR</p> <p>ALU. ADAPTIVE REAR TOE SUSPENSION JOINT HOLDER</p>
<p>125217</p>  <p>SUS 47mm</p> <p>BATTERY CHASSIS HOLDER</p>	<p>125219</p>  <p>FF RR SUS 0.5mm</p> <p>GRAPHITE ARM STRENGTHEN PLATE</p>	<p>125226-AL</p>  <p>20T ALU</p> <p>20T FIXED PULLEY (NARROW)</p>	<p>125228</p>  <p>4.0</p> <p>ALU. SOLID LAYSHAFT (NARROW)</p>
<p>125227</p>  <p>ALU. MOTOR AND SPUR GEAR SHAFT MOUNT</p>	<p>125234</p>  <p>SUS 29g</p> <p>FRONT ANTI-COLLISION PRESSING PLATE</p>	<p>125451</p>  <p>ALU FR</p> <p>ALU. FRONT ARM JOINT HOLDER</p>	<p>125452</p>  <p>ALU FL</p> <p>ALU. FRONT ARM JOINT HOLDER</p>
<p>125802</p>  <p>V2</p> <p>BATTERY FIXING ASSEMBLY V2</p>	<p>128115</p>  <p>CARBON FIBER</p> <p>ACTIVE TOE SUSPENSION SPRING</p>	<p>128261</p>  <p>2.0mm</p> <p>CARBON GRAPHITE CHASSIS</p>	<p>128262</p>  <p>3.0mm</p> <p>CARBON GRAPHITE REAR SHOCK TOWER</p>
<p>128263</p>  <p>3.0mm</p> <p>CARBON GRAPHITE REAR SHOCK TOWER</p>	<p>128264 128265 PRO</p>  <p>2.0mm</p> <p>CARBON GRAPHITE FRONT 2ND DESK</p>	<p>128173-2.0 2.0mm 128173-2.5 2.5mm</p>  <p>RL</p> <p>GRAPHITE REAR ARM V2</p>	<p>128174-2.0 2.0mm 128174-2.5 2.5mm</p>  <p>RR</p> <p>GRAPHITE REAR ARM V2</p>
<p>128171-2.0 2.0mm 128171-2.5 2.5mm</p>  <p>FL</p> <p>GRAPHITE FRONT ARM V2</p>	<p>128172-2.0 2.0mm 128172-2.5 2.5mm</p>  <p>FR</p> <p>GRAPHITE FRONT ARM V2</p>	<p>128259</p>  <p>2.0mm</p> <p>FRONT BUMPER ANTI-COLLISION PLATE</p>	<p>128268</p>  <p>V2 3.0mm</p> <p>CARBON GRAPHITE BATTERY ARM HOLDER</p>

1/10 ELECTRIC TOURING CAR

MTS T3M-V2

<p>929058</p>  <p>THREE POINT BALL</p> <p>MULTI LINK UPPER SWING ARM (CAR SHELL SUPPORT)</p>	<p>929068</p>  <p>DOUBLE BALL END</p> <p>MULTI LINK UPPER SWING ARM</p>	<p>127035</p>  <p>117T</p> <p>SYNCHRONOUS BELT LENGTH-351 117T</p>	<p>127135</p>  <p>117T FIBRE</p> <p>SYNCHRONOUS BELT (FIBRE)LENGTH-351 117T</p>		
<p>127235</p>  <p>117T PU</p> <p>SYNCHRONOUS BELT SHORT PU-351 117T</p>	<p>127335</p>  <p>117T WHITE</p> <p>SYNCHRONOUS BELT HIGH FLEXIBILITY PU 117T</p>	<p>128202</p>  <p>26mm</p> <p>DIFF GASKET 26mm</p>	<p>128210 128310 45°</p>  <p>AFTER FLOODING FOAM BUMPER</p>		
<p>129812</p>  <p>5x0.7x12x8</p> <p>ACTIVE TOE SUSPENSION SPRING</p>	<p>940060</p>  <p>6mm</p> <p>BODY CLIP</p>	<p>940100</p>  <p>6mm</p> <p>LONG BODY CLIP</p>	<p>121320</p>  <p>90°</p> <p>REARVIEW MIRROR 90°</p>		
<p>121322</p>  <p>40°</p> <p>REARVIEW MIRROR 40°</p>	<p>121324</p>  <p>PROTECTION RACK</p>	<p>128401/611710</p>  <p>195x260mm</p> <p>D12 PULL CAR SHELL PC</p>	<p>128402/611810</p>  <p>PC 195x260mm</p> <p>GTR DRIFT CAR SHELL PC 195x260mm</p>		
<p>128403/611610</p>  <p>195x260mm</p> <p>FLAT CAR SHELL PC</p>	<p>128404/611620</p>  <p>195x200mm</p> <p>FLAT CAR SHELL PC</p>	<p>128405/611630</p>  <p>195x200mm</p> <p>FLAT CAR SHELL PC</p>	<p>128406/611820</p>  <p>PC 195x260mm</p> <p>AMG DRIFT CAR SHELL PC 195X260mm</p>		
<p>994018 18T</p> <p>994019 19T</p> <p>994020 20T</p> <p>994021 21T</p> <p>994022 22T</p> <p>994023 23T</p> <p>994024 24T</p> <p>994025 25T</p>	<p>994026 26T</p> <p>994027 27T</p> <p>994028 28T</p> <p>994029 29T</p> <p>994030 30T</p> <p>994031 31T</p> <p>994032 32T</p> <p>994033 33T</p>	<p>994034 34T</p> <p>994035 35T</p> <p>994036 36T</p> <p>994037 37T</p> <p>994038 38T</p> <p>994039 39T</p> <p>994040 40T</p>  <p>48P</p>	<p>996024 24T</p> <p>996025 25T</p> <p>996026 26T</p> <p>996027 27T</p> <p>996028 28T</p> <p>996029 29T</p> <p>996030 30T</p> <p>996031 31T</p>	<p>996032 32T</p> <p>996033 33T</p> <p>996034 34T</p> <p>996035 35T</p> <p>996036 36T</p> <p>996037 37T</p> <p>996038 38T</p> <p>996039 39T</p>	<p>996040 40T</p> <p>996041 41T</p> <p>996042 42T</p> <p>996043 43T</p> <p>996044 44T</p> <p>996045 45T</p> <p>996046 46T</p>  <p>64P</p>
<p>PINION GEAR ALU HARD COATED 48P</p>			<p>PINION GEAR ALU HARD COATED 64P</p>		















1/10 ELECTRIC TOURING CAR

MTS T3M-V2

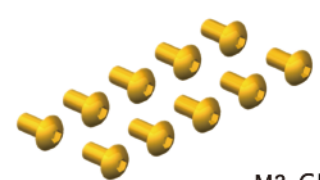
<p>994013 18T-30T 48P</p>  <p>48P</p> <p>PINION GEAR ALU HARD COATED</p>	<p>996010 24T-34T 64P 996011 35T-45T 64P</p>  <p>64P</p> <p>PINION GEAR ALU HARD COATED</p>	<p>996110 110T 996116 116T 996110-WH 110T 996116-WH 116T</p>  <p>64P</p> <p>SPUR GEAR 64P</p>	
<p>994072 72T 994081 81T 994084 84T 994087 87T 994084-WH 84T 994087-WH 87T</p>  <p>48P</p> <p>SPUR GEAR 48P</p>	<p>919502 2g 919503 3g</p>  <p>ROUND SHAPE BALANCE WEIGHT</p>	<p>919505 5g 919510 10g</p>  <p>ROUND SHAPE BALANCE WEIGHT</p>	
<p>924956 4.9xM3x6 H2.0 924958 4.9xM3x8 H2.0</p>  <p>4.9xM3</p> <p>DOUBLE BALL END 4.9 WITH THREAD</p>	<p>924968</p>  <p>4.9xM3x8 H2.0</p> <p>DOUBLE BALL END 4.9 WITH THREAD (BODY SUPPORTER)</p>	<p>924957</p>  <p>4.9xM3x8 15 H2.0</p> <p>DOUBLE BALL END 4.9 WITH THREAD (BODY SUPPORTER)</p>	<p>924959</p>  <p>4.9xM3x8 16 H2.0</p> <p>DOUBLE BALL END 4.9 WITH THREAD (BODY SUPPORTER)</p>
<p>924900</p>  <p>4.9x6mm</p> <p>DOUBLE BEVEL SHOULDERS 4.9x6mm</p>	<p>925800</p>  <p>5.8mm</p> <p>BALL UNIVERSAL 5.8x3x7.5mm HEX</p>	<p>925801</p>  <p>5.8mm M3 L3</p> <p>BALL UNIVERSAL 5.8mm M3 L3 HEX H3.0</p>	<p>924904 4.9x4 924906 4.9x6 924908 4.9x8 924910 4.9x10</p>  <p>4.9mm L4</p> <p>BALL END 4.9mm L4 WITH THREAD H2.0</p>
<p>925805 5.8x5 925806 5.8x6 925808 5.8x8 925810 5.8x10</p>  <p>5.8mm</p> <p>BALL END 5.8mm WITH THREAD H2.5</p>	<p>924916 4.9x6 L6 924918 4.9x8 L6</p>  <p>4.9mm</p> <p>BALL END 4.9mm WITH THREAD H2.0</p>	<p>924926 4.9x6 L8 924918 4.9x8 L8</p>  <p>4.9mm</p> <p>BALL END 4.9mm WITH THREAD H2.0</p>	<p>925848 5.8x8 L12</p>  <p>5.8mm</p> <p>BALL END 5.8mm L12mm WITH THREAD 8mm H3.0</p>
<p>920718 18mm 920720 20mm 920722 22mm 920724 24mm 920728 28mm 920732 32mm 920736 36mm 920740 40mm</p> <p>920745 45mm 920750 50mm</p>  <p>M3 H3 SUS410</p> <p>ADJ. TURNBUCKLE L/R M3 H3 SUS410</p>	<p>920318 18mm 920320 20mm 920322 22mm 920324 24mm 920328 28mm 920332 32mm 920336 36mm 920340 40mm</p> <p>920345 45mm 920350 50mm</p>  <p>M3 H3 S2</p> <p>ADJ. TURNBUCKLE L/R M3 H3 SPRING STEEL</p>		



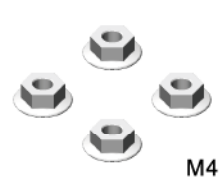
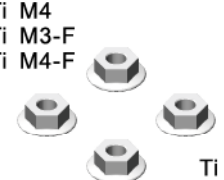
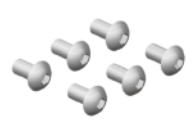







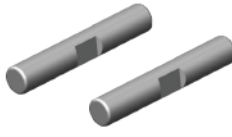
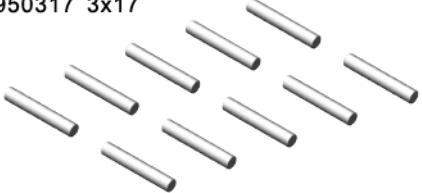

1/10 ELECTRIC TOURING CAR

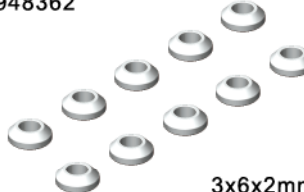
MTS T3M-V2

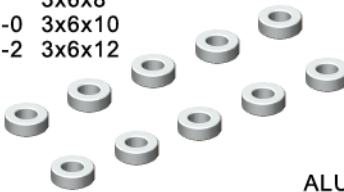
<p>916310-P M3X10 916312-P M3X12 916315-P M3X15</p>  <p>M3 PA</p> <p>HEX SOCKET CAP SCREW M3 PLASTIC</p>	<p>915325 M3x2.5 915303 M3x3 915304 M3x4 915306 M3x6 915308 M3x8 915310 M3x10 915312 M3x12 915314 M3x14 915408 M4x8</p>  <p>HEX SET SCREW M3 / M4</p>	<p>916205 M2x5 916256 M2.5x6 916110 M2.5x10</p>  <p>M2.5</p> <p>HEX SOCKET CAP SCREW M2.5</p>	<p>916308 M3x8 916310 M3x10 916312 M3x12 916314 M3x14 916316 M3x16 916318 M3x18 916320 M3x20 916322 M3x22 916325 M3x25</p>  <p>M3</p> <p>HEX SOCKET CAP SCREW M3</p>
<p>918206 M2x6 918208 M2x8 918210 M2x10 918256 M2.5x6 918258 M2.5x8 918110 M2.5x10 918112 M2.5x12 918114 M2.5x14</p> <p>918304 M3x4 918305 M3x5 918306 M3x6 918308 M3x8 918310 M3x10 918312 M3x12 918314 M3x14 918316 M3x16</p>  <p>M2 / M2.5 M3</p> <p>HEX SCREW ROUND HEAD</p>		<p>917256 M2.5x6 917258 M2.5x8</p> <p>917304 M3x4 917306 M3x6 917308 M3x8 917310 M3x10 917312 M3x12 917314 M3x14 917316 M3x16</p>  <p>M2.5 M3</p> <p>HEX SCREW FLAT HEAD M3</p>	
<p>915325-GD M3x2.5 GD 915304-GD M3x4 GD 915306-GD M3x6 GD 915308-GD M3x8 GD 915310-GD M3x10 GD 915312-GD M3x12 GD 915314-GD M3x14 GD</p>  <p>M3-GD</p> <p>HEX SET SCREW M3-GD</p>		<p>916205-GD M2x5 GD</p>  <p>M2.5-GD</p> <p>HEX SOCKET CAP SCREW M2.5</p>	<p>918256-GD M2.5x6 GD 918110-GD M2.5x10 GD 918112-GD M2.5x12 GD 918114-GD M2.5x14 GD</p>  <p>M2.5-GD</p> <p>HEX SCREW ROUND HEAD M2.5-GD</p>
<p>918304-GD M3x4 GD 918305-GD M3x5 GD 918306-GD M3x6 GD 918308-GD M3x8 GD 918310-GD M3x10 GD 918312-GD M3x12 GD 918314-GD M3x14 GD 918316-GD M3x16 GD</p>  <p>M3-GD</p> <p>HEX SCREW ROUND HEAD M3-GD</p>		<p>917256-GD M2.5x6 917258-GD M2.5x8</p> <p>917304-GD M3x4 917306-GD M3x6 917308-GD M3x8 917310-GD M3x10 917312-GD M3x12 917314-GD M3x14 917316-GD M3x16</p>  <p>M2.5 / M3-GD</p> <p>HEX SCREW FLAT HEAD M2.5 M3-GD</p>	
<p>910105-GD</p>  <p>ALL METAL SCREW</p>	<p>919300 M3 919400 M4 919301 M3-F 919401 M4-F</p>  <p>M3 / M4</p> <p>NUT M3 / M4</p>	<p>919402 M4-ALU</p>  <p>M4 ALU</p> <p>NUT M4</p>	<p>919300-Ti M3 919400-Ti M4 919301-Ti M3-F 919401-Ti M4-F</p>  <p>Ti</p> <p>NUT M3 / M4</p>
<p>918254-Ti M2.5x4 Ti 918256-Ti M2.5x6 Ti 918258-Ti M2.5x8 Ti 918110-Ti M2.5x10 Ti 918112-Ti M2.5x12 Ti 918114-Ti M2.5x14 Ti</p> <p>918304-Ti M3x4 Ti 918305-Ti M3x5 Ti 918306-Ti M3x6 Ti 918308-Ti M3x8 Ti 918310-Ti M3x10 Ti 918312-Ti M3x12 Ti 918314-Ti M3x14 Ti 918316-Ti M3x16 Ti</p>  <p>M2.5 / M3-Ti</p> <p>HEX SCREW ROUND HEAD M2.5 M3-Ti</p>		<p>917254-Ti M2.5x4 Ti 917256-Ti M2.5x6 Ti 917258-Ti M2.5x8 Ti 917110-Ti M2.5x10 Ti</p>  <p>M2.5-Ti</p> <p>HEX SCREW FLAT HEAD M2.5-Ti</p>	

1/10 ELECTRIC TOURING CAR

MTS T3M-V2

<p>917304-Ti M3x4 Ti 917305-Ti M3x5 Ti 917306-Ti M3x6 Ti 917308-Ti M3x8 Ti 917310-Ti M3x10 Ti 917312-Ti M3x12 Ti 917314-Ti M3x14 Ti 917316-Ti M3x16 Ti</p>  <p>M3-Ti</p> <p>HEX SCREW FLAT HEAD M3-Ti</p>		<p>930306 3x6x2.5 930308 3x8x4 930418 4x8x3-F 930410 4x10x4 930518 5x8x2.5-F 930508 5x8x2.5 930510 5x10x4 930612 6x12x4</p>	<p>931015 10x15x4</p>  <p>BALL-BEARING</p>
<p>930115 T3-V2</p>  <p>WHOLE VEHICLE BEARING</p>	<p>950318 3x18mm 950320 3x20mm</p>  <p>FRONT PIVOT PIN FOR C-HUB</p>	<p>951509 1.5x9 951510 1.5x9.8 951518 1.5x18 950209 2x9 950210 2x9.8 950212 2x12 950218 2x18 950312 3x12</p>	<p>950317 3x17</p>  <p>PIN</p>
<p>940025 C2.5 940030 C3 940040 C4 940050 C5</p>  <p>E-CLIP</p>	<p>947262 2.5x6x2 947362 3x6x2</p>  <p>ALU</p> <p>WASHER SFH SCREW FLAT HEAD-ALU</p>	<p>948362</p>  <p>3x6x2mm</p> <p>CONICAL SHIM-ALU</p>	<p>940391 3x9x1 940391-5 3x9x1.5 940392 3x9x2</p>  <p>ALU</p> <p>WASHER-ALU</p>
<p>940361 3x6x1 940361-5 3x6x1.5 940362 3x6x2 940362-5 3x6x2.5 940363 3x6x3 940364 3x6x4 940365 3x6x5 940366 3x6x6</p>	<p>940368 3x6x8 940361-0 3x6x10 940361-2 3x6x12</p>  <p>ALU</p> <p>WASHER-ALU</p>	<p>940265 2.6x6 940272 2.6x7 940373 3x7x0.3 940375 3x7x0.5 943581 3.5x8x0.1 943582 3.5x8x0.2 943583 3.5x8x0.3 943591 3.5x9x0.1</p>	<p>943592 3.5x9x0.2 943593 3.5x9x0.3 943594 3.5x9x0.4 945101 5x10x0.1 945102 5x10x0.2 945103 5x10x0.3 945111 5x11x0.1 945122 5x12x0.2</p> <p>945133 5x13x0.3 941502 12x14.8x0.2 941503 12x14.8x0.3</p>  <p>STEEL</p> <p>WASHER</p>
<p>944003 4x10x0.3 944005 4x10x0.5 945082 5x8x0.2 945083 5x8x0.3 946003 6x11.5x0.3 947005 7x12x0.5 948003 8x12x0.3 948005 8x12x0.5</p>	<p>941302 13.2x15.9x0.2 941303 13.2x15.9x0.3 941304 13.2x15.9x0.4 941305 13.2x15.9x0.5</p>  <p>STEEL</p> <p>WASHER</p>	<p>960615 6x1.5 960702 7x2 960722 7x2.2 960802 8x2 960822 8x2.2 960825 8x2.5 960902 9x2 961124 11x2.4</p>	<p>961301 13x1 961401 14x1 961501 15x1-13</p>  <p>SILICONE O-RING</p>
<p>909009 HIGH STRENGTH SCREW GLUE 909010 MEDIUM STRENGTH SCREW GLUE 909011 STICKY RUBBER 909012 FUEL LUBRICATION ADDITIVE</p>  <p>STICKY RUBBER</p>		<p>900100 THE DIFFERENTIAL OIL 900050 SHOCK ABSORBER OIL 909001 GRAPHITE OIL 909002 ENGINE AFTER RUN OIL 909003 AIR FILTER OIL 909004 ONE-WAY LUBE 909005 CERAMIC BEAD OIL 909006 SINGLE BEARING OIL</p>	<p>909007 HIGH SPEED BEARING OIL 909008 SEAL OIL</p>  <p>OIL</p>