

# S35-T2

1/8 OffRoad Nitro Power Pro Truggy



SWORKZ S35-T2 INSTRUCTION MANUAL



# **S35-T2**

## **1/8 OffRoad Nitro Power Pro Truggy**

### **INSTRUCTION**

The SWORKz S35-T2 1/8 Nitro Truggy is designed for pure racing. The geometry of the car provides great corner speed with exceptional traction and easy driving control.

The S35-T2 features a T7075 hard anodized and lightened aluminum wide layout chassis that was tested by our factory pilots to guarantee best performance.

The newly developed Truggy HET differentials are included and provide traction that was not possible before.

The new S35-T2 comes with a longer shock layout in the front and rear. The construction of the shocks is adapted to that new optimized layout. The smart holder for shock spring plates makes it almost impossible to lose them anymore.

The steering geometry, with new Ackerman and steering plates, gives the driver a feeling of total control over the SWORKz S35-T2.

With the new toe-in plates, which now contain square inserts, you can adjust the geometry of your SWORKz S35-T2 to fit every track layout and track condition. The lower arms are made of a newly developed composite material and fit perfectly to the new chassis. Side guards were redesigned as well.

With the new lightened wing support you can adjust various positions and the angle of the wing to give your SWORKz S35-T2 the best stability on the track. Together with the "Speed Rhinoceros III" body shell, perfect aerodynamics is achieved.

Another new development in our SWORKz S35-T2 is the totally new rear hub. Made from composite materials combined with 2 carbon plates gives you the possibility for various setups.

There are many changes and smart ideas put into your new SWORKz S35-T2 that makes the car a real winner.

The secret of a modern racing car is the possibility to adapt the setup to every track for top pilots but also have a standard setup that works on most tracks for hobby pilots.

The SWORKz S35-T2 represents these two characteristics in perfection.

The SWORKz development team focused on using materials corresponding to the highest quality standards when designing the car. You will find only 100% SWORKz quality in the S35-T2 kit.

Congratulations on your purchase of the new SWORKz S35-T2 1/8 scale off-road racing Truggy pro kit and thanks for trusting in SWORKz.

Please read this manual carefully, before you start to build and drive your SWORKz S35-T2. This manual contains step-by-step instructions to helping you completing, preparing and fine tuning your Truggy for racing. Updates, setups, and product news will be posted on all SWORKz digital media.

As always, if you should ever have any questions or need help with your SWORKz products, please feel free to contact our official SWORKz dealers and distributors.

### **S35-T2 Kit Features:**

- New T7075 Hard Anodized, Lightend Aluminium Chassis
- New Wide Chassis Design
- New Design Shock Towers
- New Shock Caps
- New Fixed Shock Spring Holder
- New 3mm Updated Rear Shock Studs
- New Ackerman Plate
- New Steering System
- New Servo Saver Aluminium Part
- New Servo Saver Fixable Nut
- New Servo Saver Plate
- New Servo Saver Post Locking Design
- New Steering Balls
- New Steering Knuckle Plates
- New Updated Toe-In Plates with Square Inserts
- New Lightweight Wing Mount
- New Side Guards
- New Lower Front and Rear Arms
- New Front Upper Arms
- New Body Posts Front and Rear
- New Composite Rear Hubs with Carbon Plates
- New Multi Adjustable Ball System for Rear Upper Arms
- New Anticlock Screws for Shocks
- 3 HET Differentials Included
- New Front and Rear Universal Cross Drive Shafts
- 2 Front Chassis Braces Included
- Black Competition Shock Springs Included
- Adjustable Wing Position
- Adjustable Wing Angle

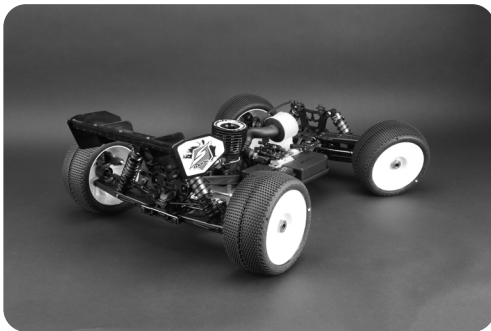

<b>Specification</b>	
<b>Length:</b>	<b>560mm</b>
<b>Width:</b>	<b>410mm</b>
<b>Height:</b>	<b>230mm</b>
<b>Ground Clearance:</b>	<b>80mm</b>
<b>Wheelbase:</b>	<b>375-380mm</b>
<b>Track:</b>	<b>F:366mm /R:368mm</b>
<b>Gear Ratio:</b>	<b>C:48/13T, F/R:46/10T</b>
<b>Weight:</b>	<b>3980g (Race condition)</b>

## **WARRANTY**

Your SWORKz S35-T2 kit warranty covers workmanship and manufacturing defects of the original and unmodified parts. Warranty claims resulting from crashes, abuse, improper operation, improper mounting, improper adjustment or lack of maintenance will not be honored.

Contact your local hobby shop or SWORKz distributor for all claims and questions. Claims must be well documented. All Claims are subject to expert examination approval by SWORKz.



<b>INSTRUCTION</b>	<b>2</b>
<b>Warranty</b>	<b>3</b>
<b>INDEX</b>	<b>4</b>
<b>Required Equipment for Operation</b>	<b>5</b>
<b>Operation Guide</b>	<b>6</b>
<b>Assembly Steps</b>	<b>7-37</b>
<b>Set-up sheet</b>	<b>38</b>
<b>Blank Set-up Sheet</b>	<b>39</b>
<b>S35-T2 Key No. List</b>	<b>40-41</b>
<b>S35-T2 Spare Part List</b>	<b>41-42</b>
<b>S35-T2 Option Part List</b>	<b>43</b>
<b>End cover</b>	<b>44</b>



**This radio controlled racing car is not a toy!**

**This high-performance R/C model is recommended for ages 14 and older.**

# Required Equipment for Operation

## Radio Gear

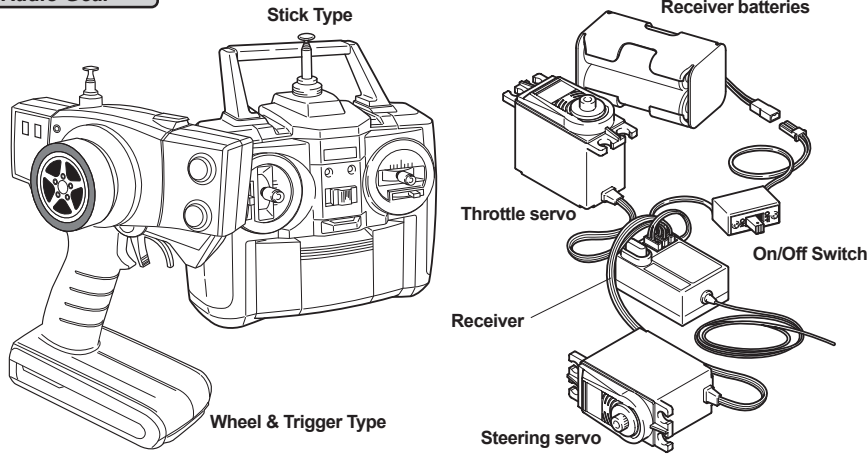

## Nitro fuel

We recommend that you use fuel containing 20~25% nitro.



## Engine Recommended

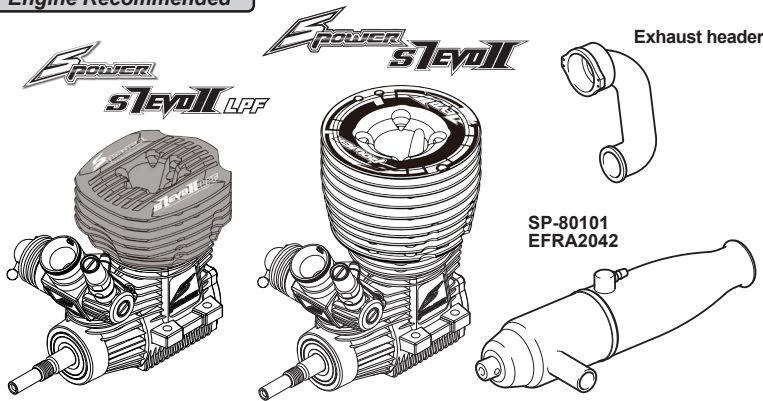

## Engine Starting Equipment

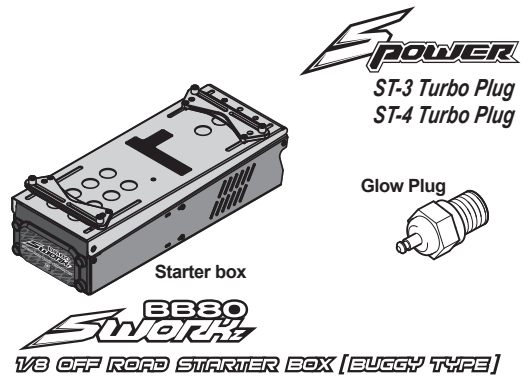

## Tools Recommended

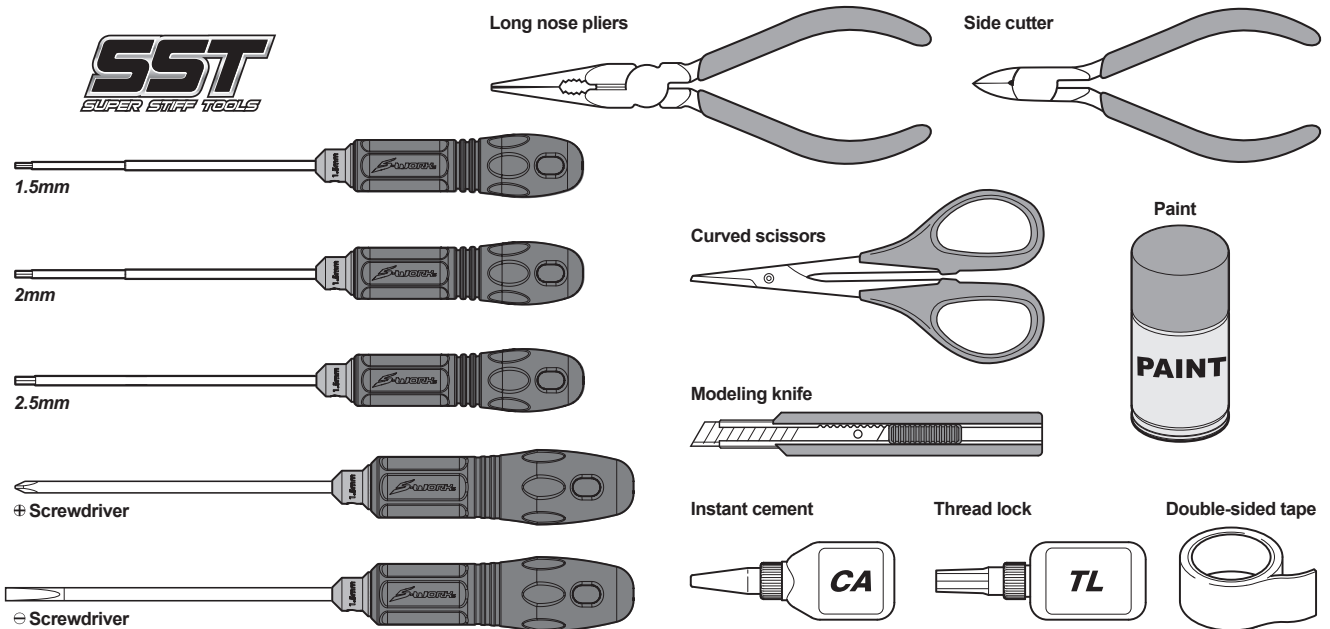

## Included items

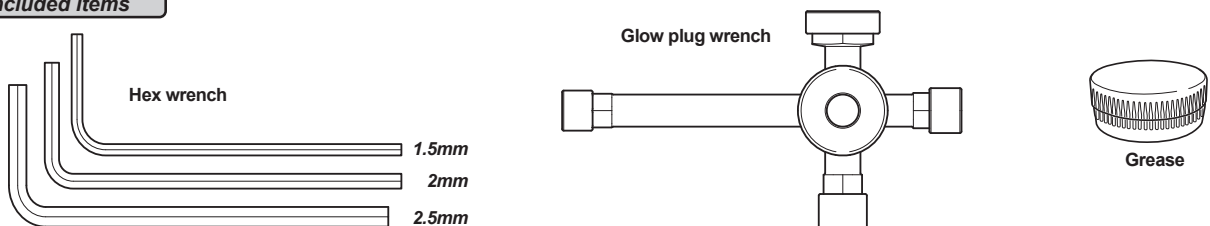

## Operation Guide



Assemble front and rear

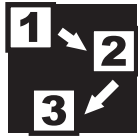

Assemble in the specified order

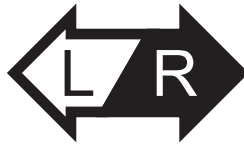

Assemble both left and right sides



Assemble for 2 sets



Assemble for 4 sets

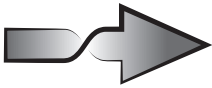

overturn



Thread Locking Compound



Grease

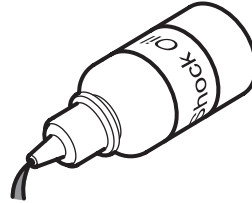

Pure Silicone Oil



Air filter oil

## Safety Precautions

The SWORKz S35-T2 is a high performance radio control model which needs to be operated with caution and common sense.

The S35-T2 Kit is not intended for children under the age of 14 without adult supervision. SWORKz shall not be held liable for any loss or damages, whether direct, indirect, act of nature, arising from the abuse or misuse of this product or any other product required while operating this model.

- The nitro fuel can be dangerous is improperly handled.
- Always keep your nitro fuel in a cool area and never use near flame, sparks, or while smoking.
- Keep your nitro fuel, and all other flammables, out of the reach of children.
- Always run your model in a well ventilated area outdoors. Never run your model indoors.
- After running your car, all parts of the engine and exhaust can become extremely hot. Be careful not to touch these parts especially when refueling, or making repairs.
- This model is controlled by your radio controller and is sometimes vulnerable to interference from many outside sources. This interference can cause a loss of control so it is necessary to operate this model in an open area to avoid personal, or property damage. Always ensure turning on your radio first.
- Keep all the parts included in the package out of reach of children.
- This model contains many fast rotating parts. Never touch them during operation.
- Follow the instructions included with your radio gear.
- Never operate your model near people or property. The speed of this model has the potential to injure and or damage people and or property.
- Always use original SWORKz spare parts and option parts.
- Always ensure that the buggy is in proper working condition before use.

# BAG B

**1** **F** **R** **x2**

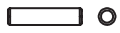

**330015**  
Pin M2.2x9.9mm x4



**400002**  
O-ring S5 4.8X1.5 x4

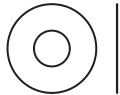

**101039**  
Washer 5x12x0.3 x2



**116006R**  
Ball Bearing 8x16x5mm (Red Rubber Case) x4

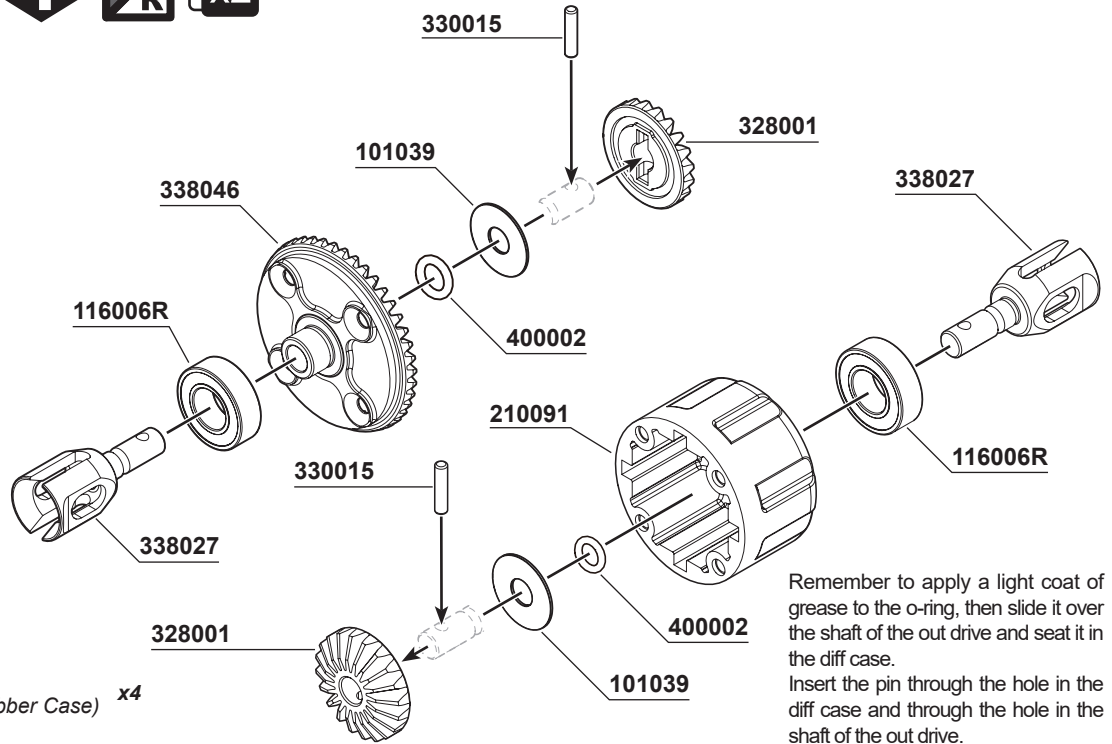

Remember to apply a light coat of grease to the o-ring, then slide it over the shaft of the out drive and seat it in the diff case.  
Insert the pin through the hole in the diff case and through the hole in the shaft of the out drive.

**2** **F** **R** **x2**



**108003**  
M3x10mm FH/ST HEX Screw x8

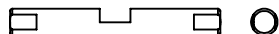

**338025**  
S35-3W Bevel Gear Shaft x4



**101004**  
Washer 3.5X10X0.2mm x8

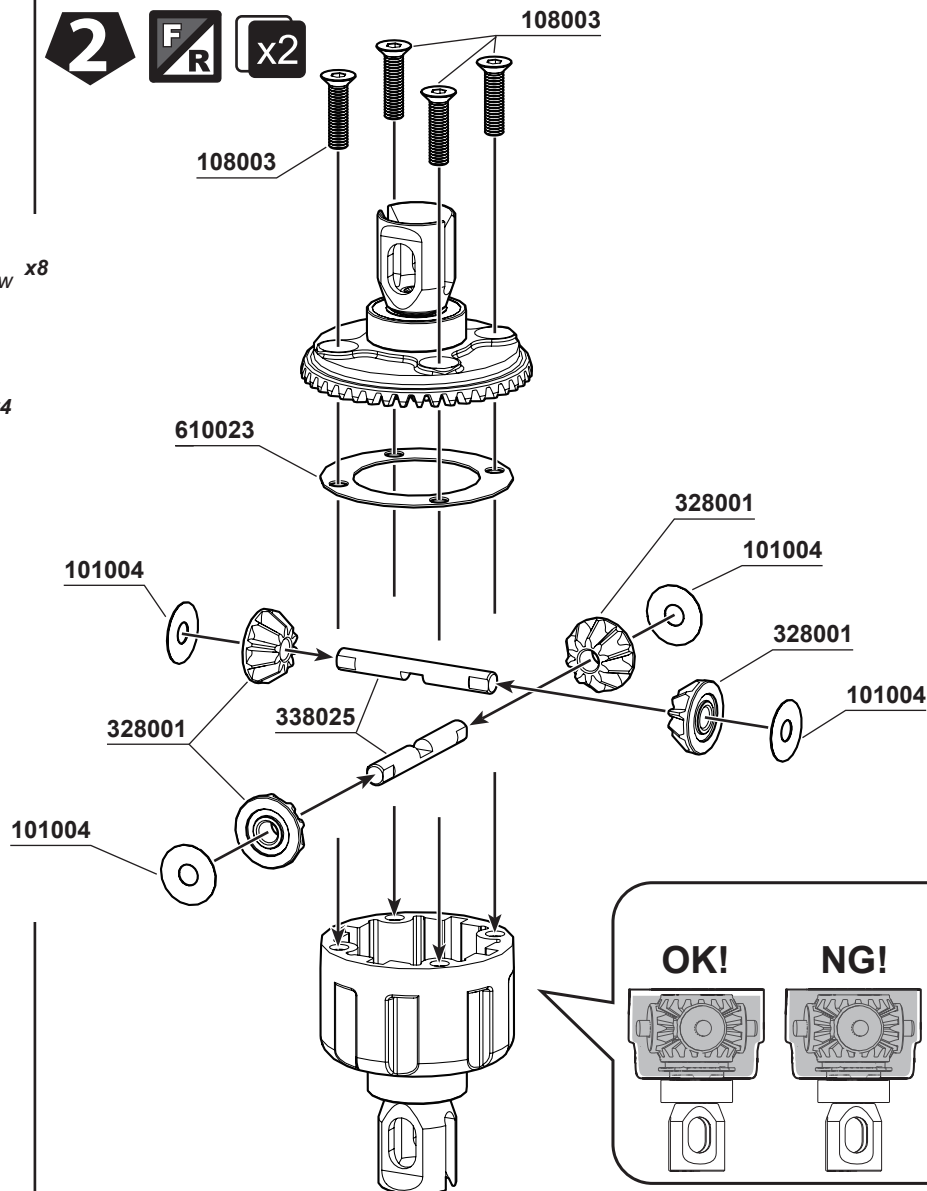

**OK!**

**NG!**

Fill the differentials with oil up to 80% above the satellite gears.  
Put the SWORKz Diff. Oil 7000cps for the front Diff. and 3000cps for the rear Diff.

**330015**  
Pin M2.2x9.9mm x2

**400002**  
O-ring S5 4.8X1.5 x2



**116006R**  
Ball Bearing 8x16x5mm (Red Rubber Case) x2

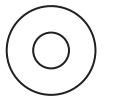

**101039**  
Washer 5x12x0.3 x2

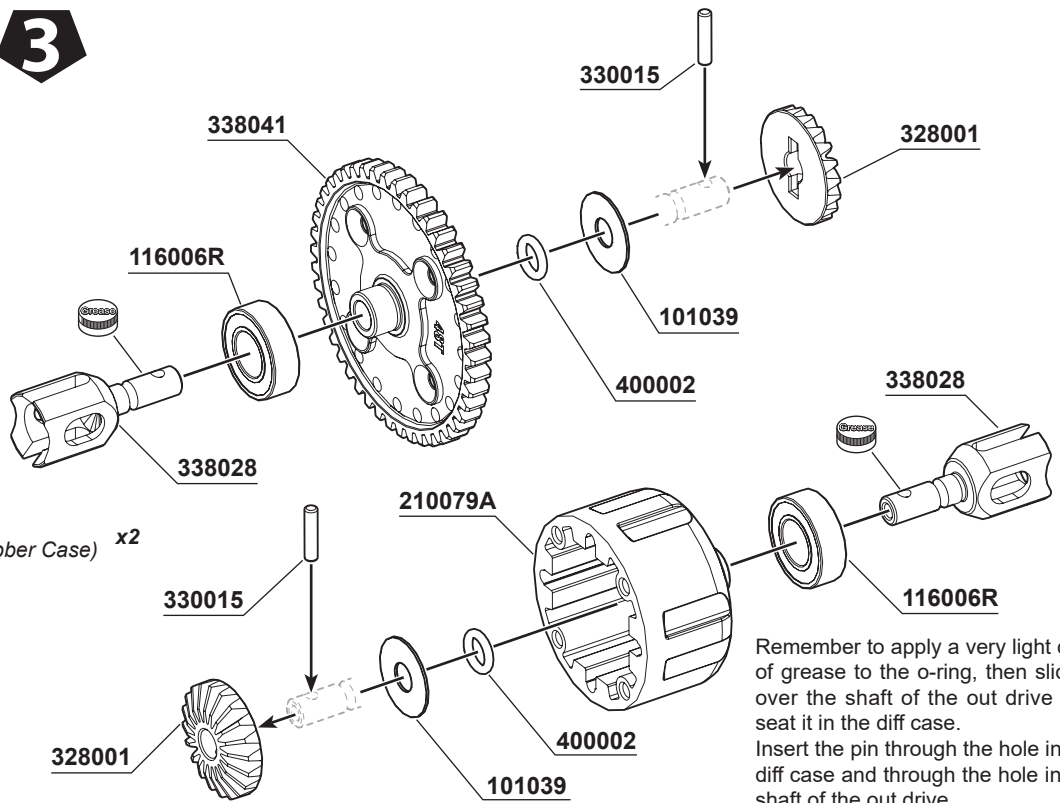

Remember to apply a very light coat of grease to the o-ring, then slide it over the shaft of the out drive and seat it in the diff case. Insert the pin through the hole in the diff case and through the hole in the shaft of the out drive.



**108001**  
M3x12mm FH/ST HEX Screw x4

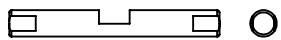

**338025**  
S35-3W Bevel Gear Shaft x4

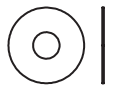

**101004**  
Washer 3.5X10X0.2mm x4

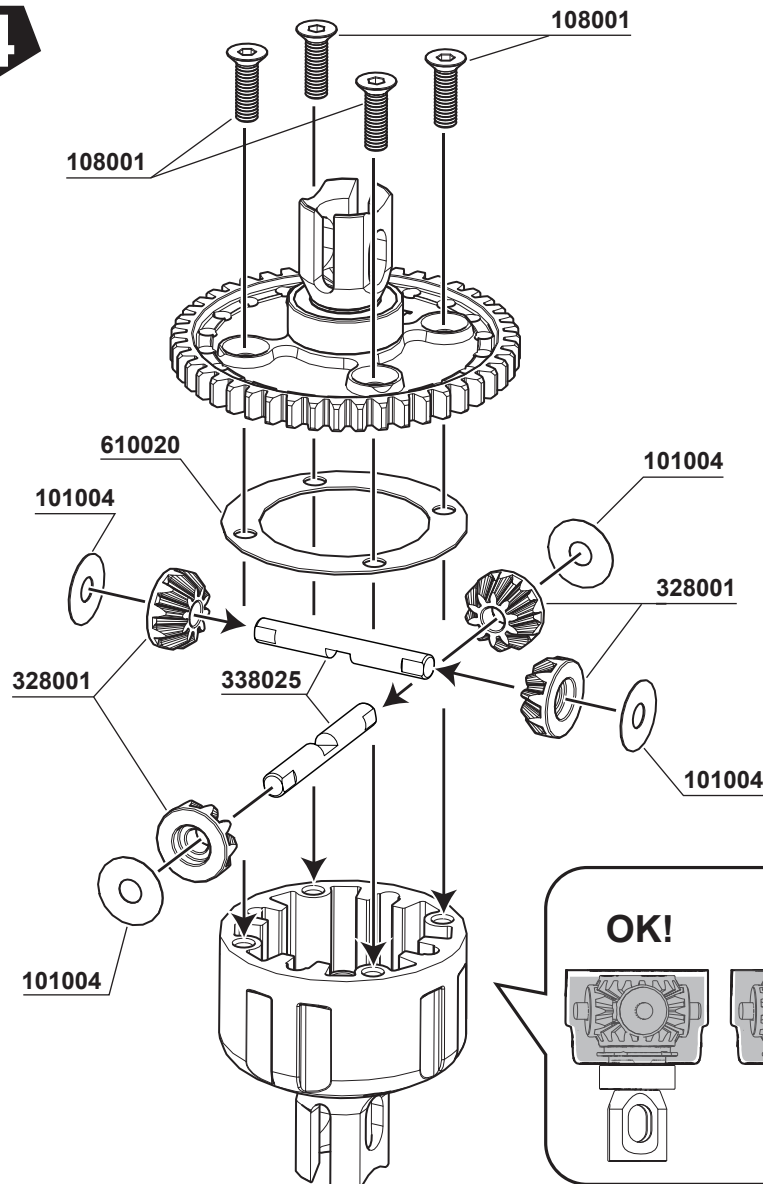

**OK!**

**NG!**

Fill the differentials with oil up to 80% above the satellite gears. Put the SWORKz Diff. Oil 7000cps for the center Diff.



Pro Tip:  
Before installing the M5x4 set screw (104010), remember to clean the set screw and center driver joint (330661A) first. Then apply TLC on the set screw.



**104010**  
M5x4mm Set Screw (Flat Bottom) **x1**



**108001**  
M3x12mm FH/ST HEX Screw **x4**



**116019R**  
Ball Bearing 5x13x4mm (Red Rubber Case) **x2**

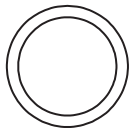

**101018**  
SHIM 13x16x0.2mm **x4**



**338011**  
S35 series Pinion Gear Stopper (5x7x5.1mm) **x1**

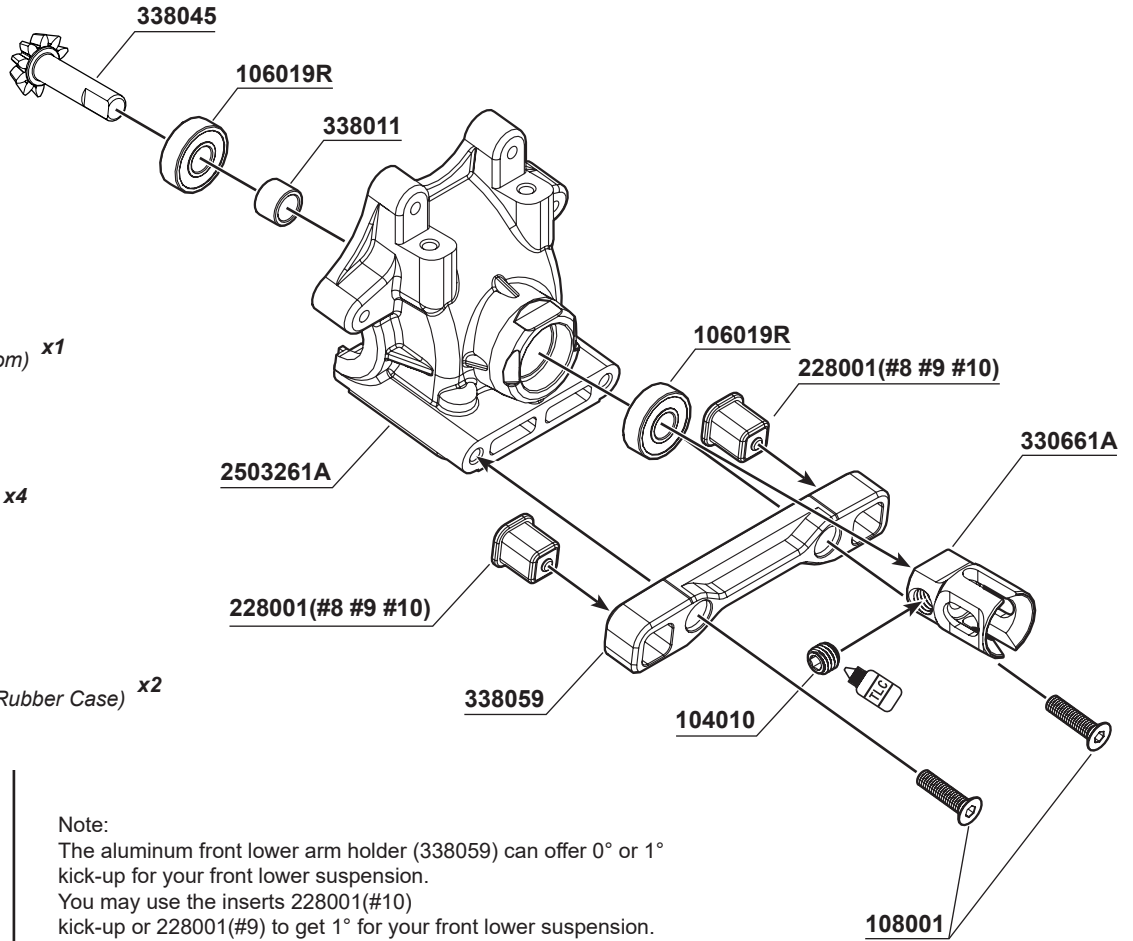

Note:  
The aluminum front lower arm holder (338059) can offer 0° or 1° kick-up for your front lower suspension. You may use the inserts 228001(#10) kick-up or 228001(#9) to get 1° for your front lower suspension.

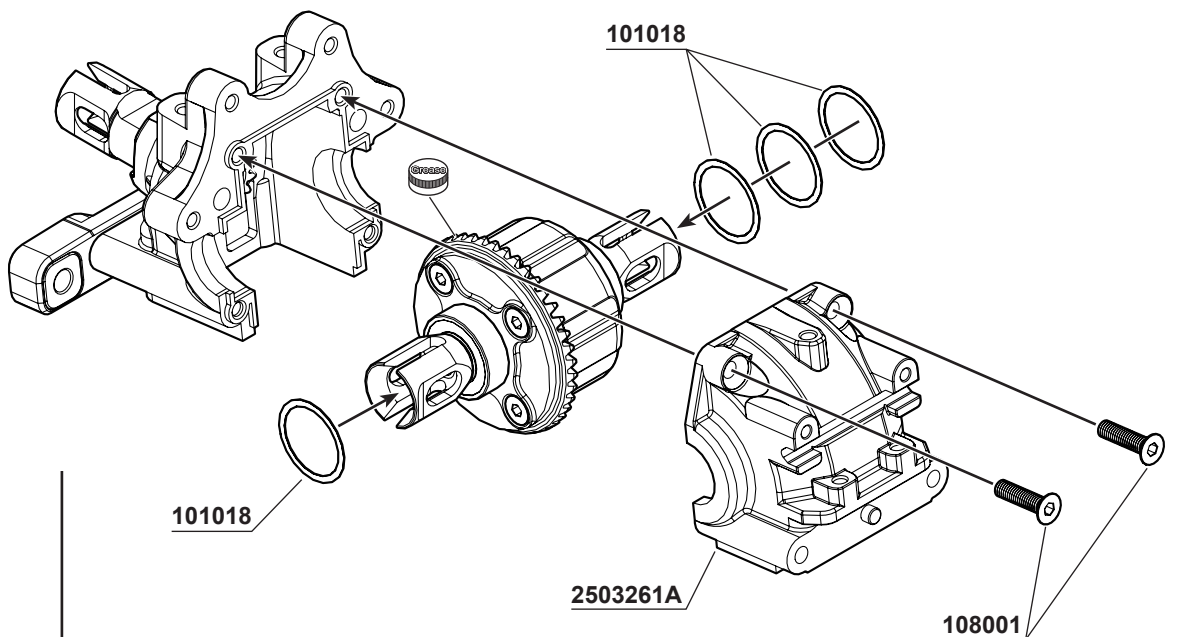

Note:  
**101018SHIM 13x16x0.2mm**  
Please use 13x16x0.2mm shims to adjust the play between the crown gear and pinion gear. Standard suggestion is 1pc shim on the diff crown gear side and 3 pcs on the other side.





**108008**  
M3x35mm FH/ST HEX Screw **x2**

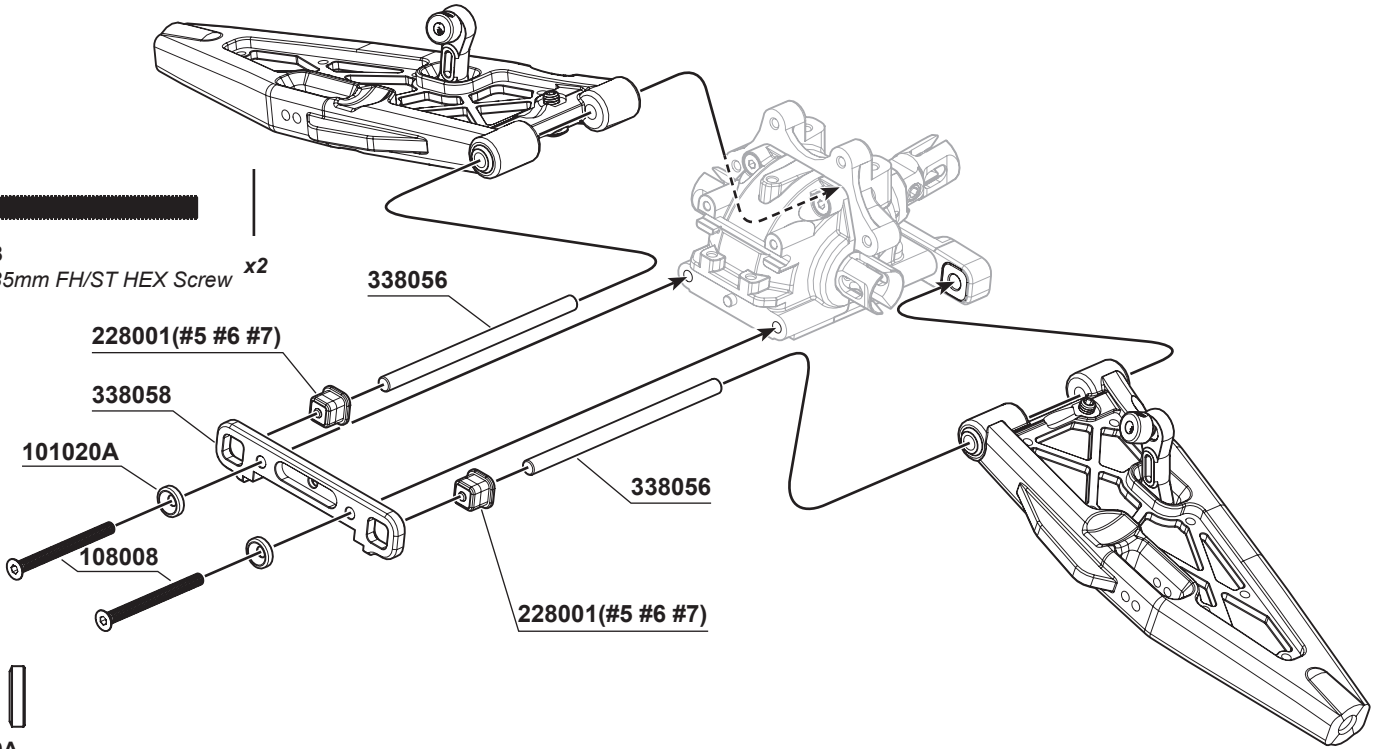

**101020A**  
3mm Countersunk Washers (GM) **x2**

**9**



**104004**  
M3x3mm Set Screw **x2**

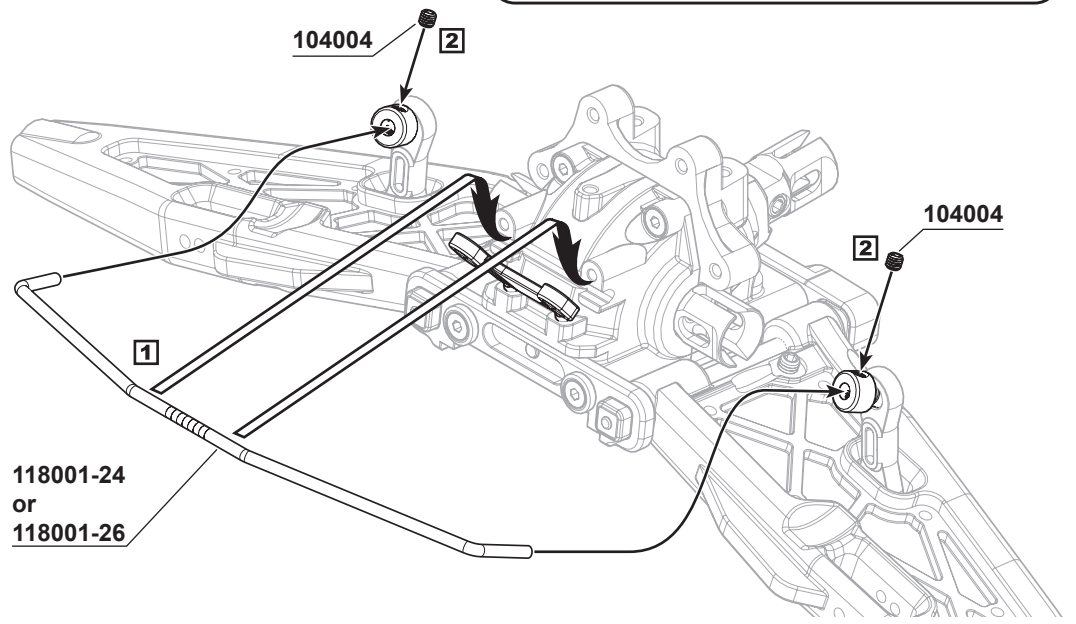
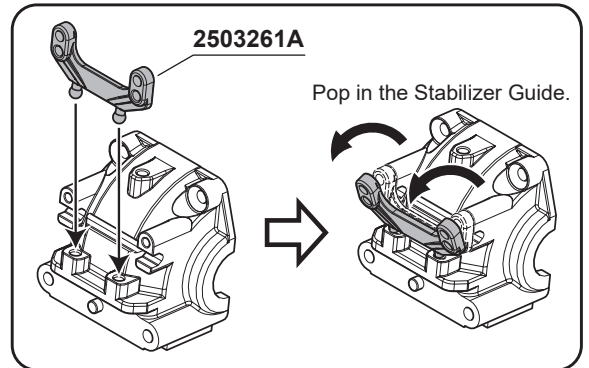

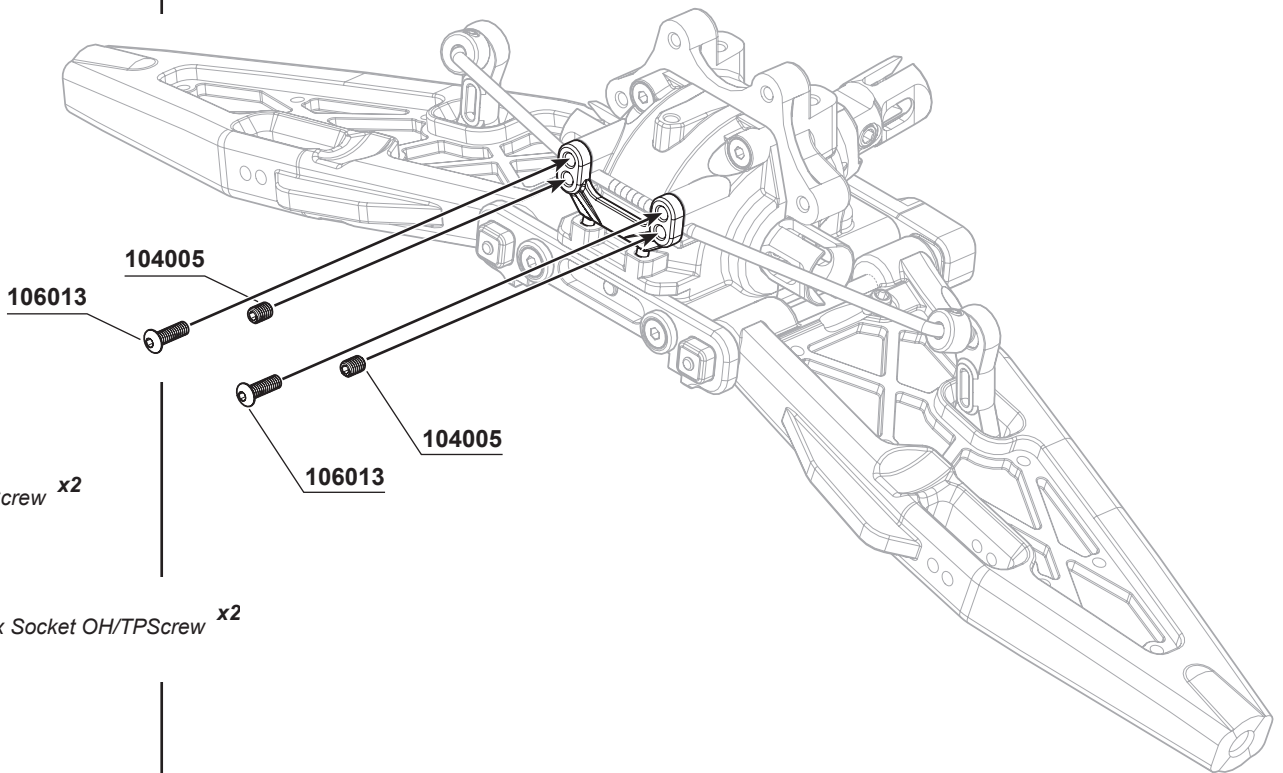

 **104005**  
M3x4mm Set Screw x2

 **106013**  
M2.5x8mmH ex Socket OH/TPScrew x2

**11**   **x2**

Note:  
The aluminum front upper arm holder (338057) can offer either 0° or + -1° kick-up for your front upper arm suspension. You may use the inserts 228001(#13) to get 0° kick-up or 228001(#12) to get + -1° for your front upper suspension.

 **108003**  
M3x10mm FH/ST HEX Screw x2

 **108006**  
M3x8mm FH/ST HEX Screw x2

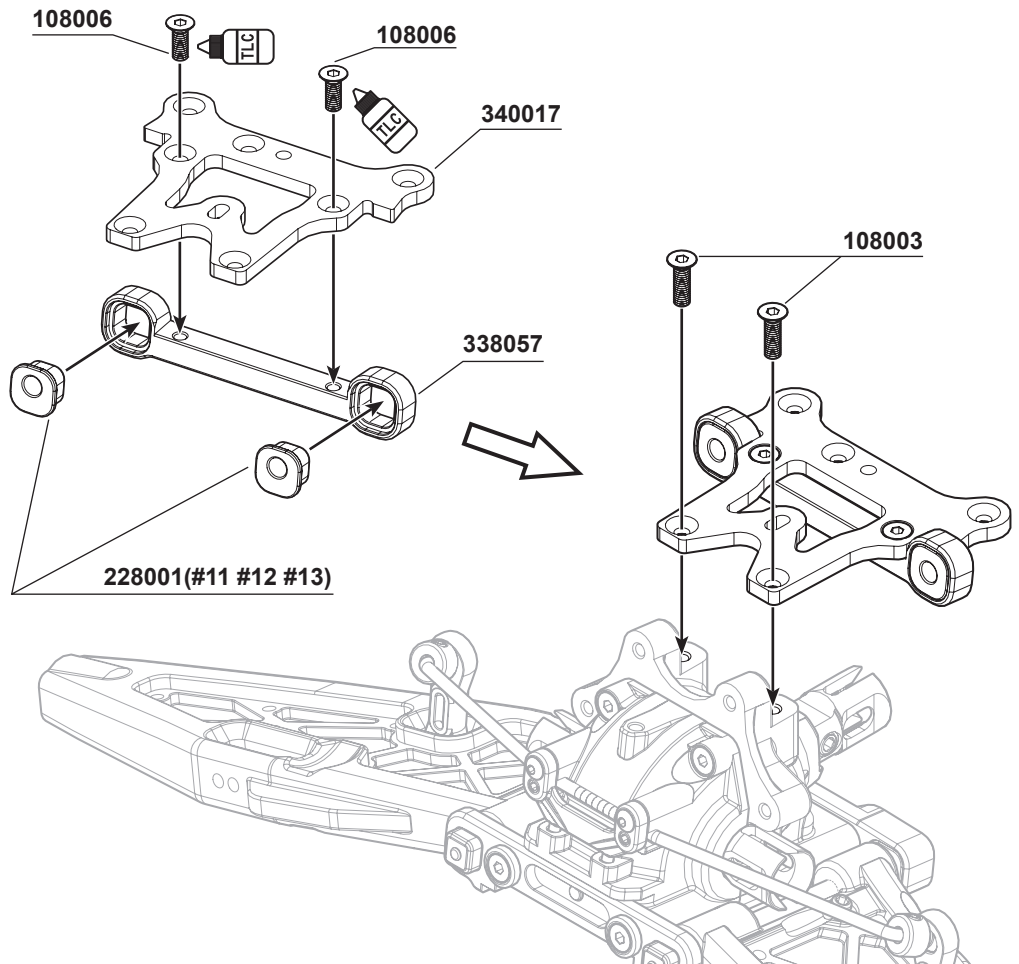

**BAG****E1****12****L R****x2****108001**  
M3x12mm FH/ST HEX Screw **x4****106015**  
M3x5mm Hex Socket OH/TP Screw **x2**

2502040-02

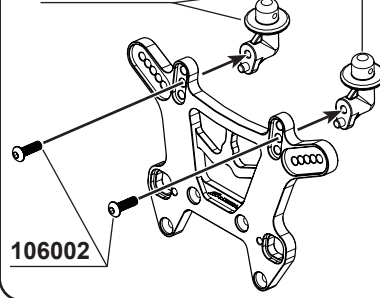

106002

**PRO TIP:**

The S35-T2 Front Upper Arm Adjust Inserts can give different steering adjustments (Ackerman). Put all inserts behind the front upper arms, you will get faster steering response. Otherwise put all inserts in front of the upper arms, you will get more stable steering response. Try to use 2503260-1 or 2503260-3 to adjust the front upper arm position.

228011

2503260(#1 #2 #3 #4)

338085

330119

228001(#14 #15 #16)

106015

2503260(#1 #2 #3 #4)

330119

108001

228001  
(#14 #15 #16)

106015

106020

340028-10

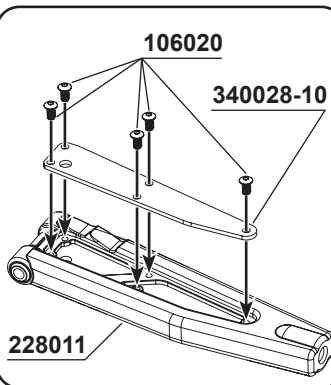

228011

228011

## Note:

- 2503260-1
- S35-3 Front Upper Arm Adjust Insert (0.9mm)
- 2503260-2
- S35-3 Front Upper Arm Adjust Insert (1.0mm)
- 2503260-3
- S35-3 Front Upper Arm Adjust Insert (1.1mm)
- 2503260-4
- S35-3 Front Upper Arm Adjust Insert (2.0mm)

330119

Front Upper Arm Hinge Pin **x2****13****L R****x2****106005**  
M3x15mm Hex Socket OH/TP Screw **x2****106021A**  
M4x10mm Hex Socket OH/TP Screw **x2**

106021A

106005

228010-R

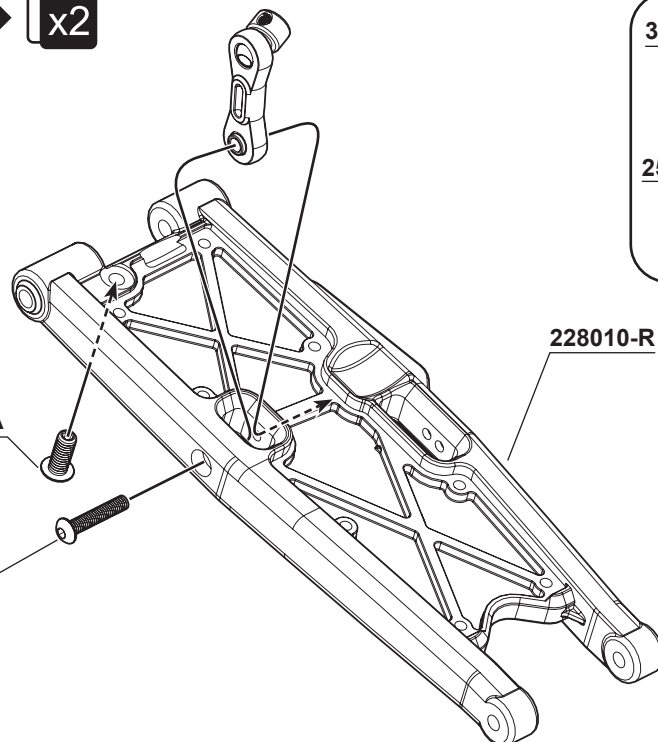

330136

2501121C

330134

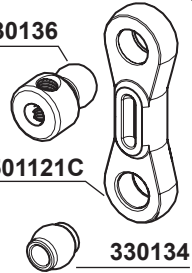



**108001**  
M3x12mm FH/ST HEX Screw x4



**108005**  
M3x14mm FH/ST HEX Screw x2



**106002**  
M3x10mm Hex Socket OH/TP Screw x2

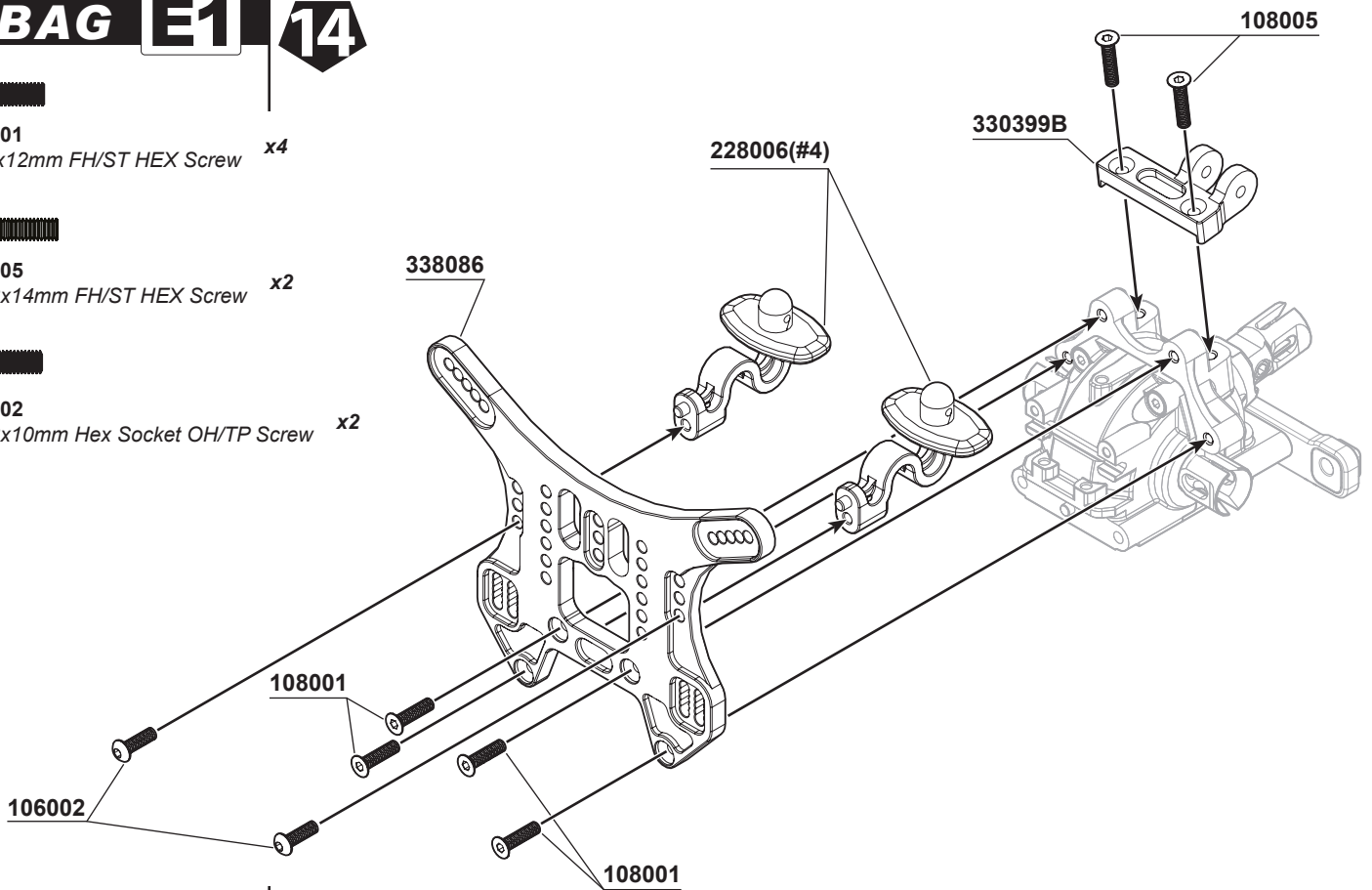

**15**



**108008**  
M3x35mm FH/ST HEX Screw x2

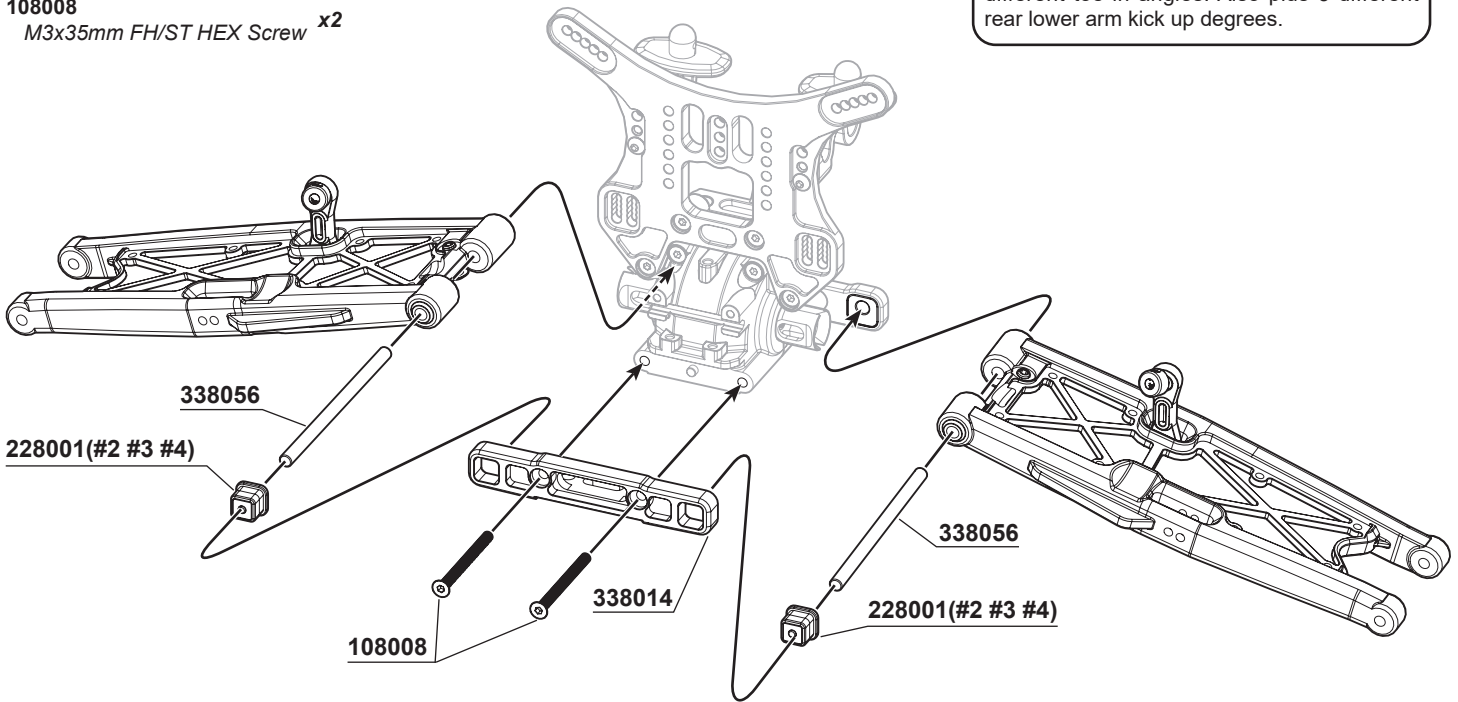

**PRO TIP:**  
The S35-T2 Aluminum Rear Lower Fully Adjustable Toe-In Block (338014) can use 3 types of square inserts to get 1.0/2.0/3.0 3 different toe in angles. Also plus 3 different rear lower arm kick up degrees.

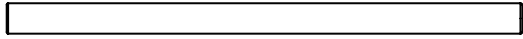

**338056**  
S35-4 Series Lower Arm Hinge Pin (68.5mm) x2

**OPTION:**  
228001-2 S35-4 Series Rear Lower Arm Holder Square Insert (+1/+1)  
228001-3 S35-4 Series Rear Lower Arm Holder Square Insert (0/+1)  
228001-4 S35-4 Series Rear Lower Arm Holder Square Insert (0)



104004  
M3x3mm Set Screw x2

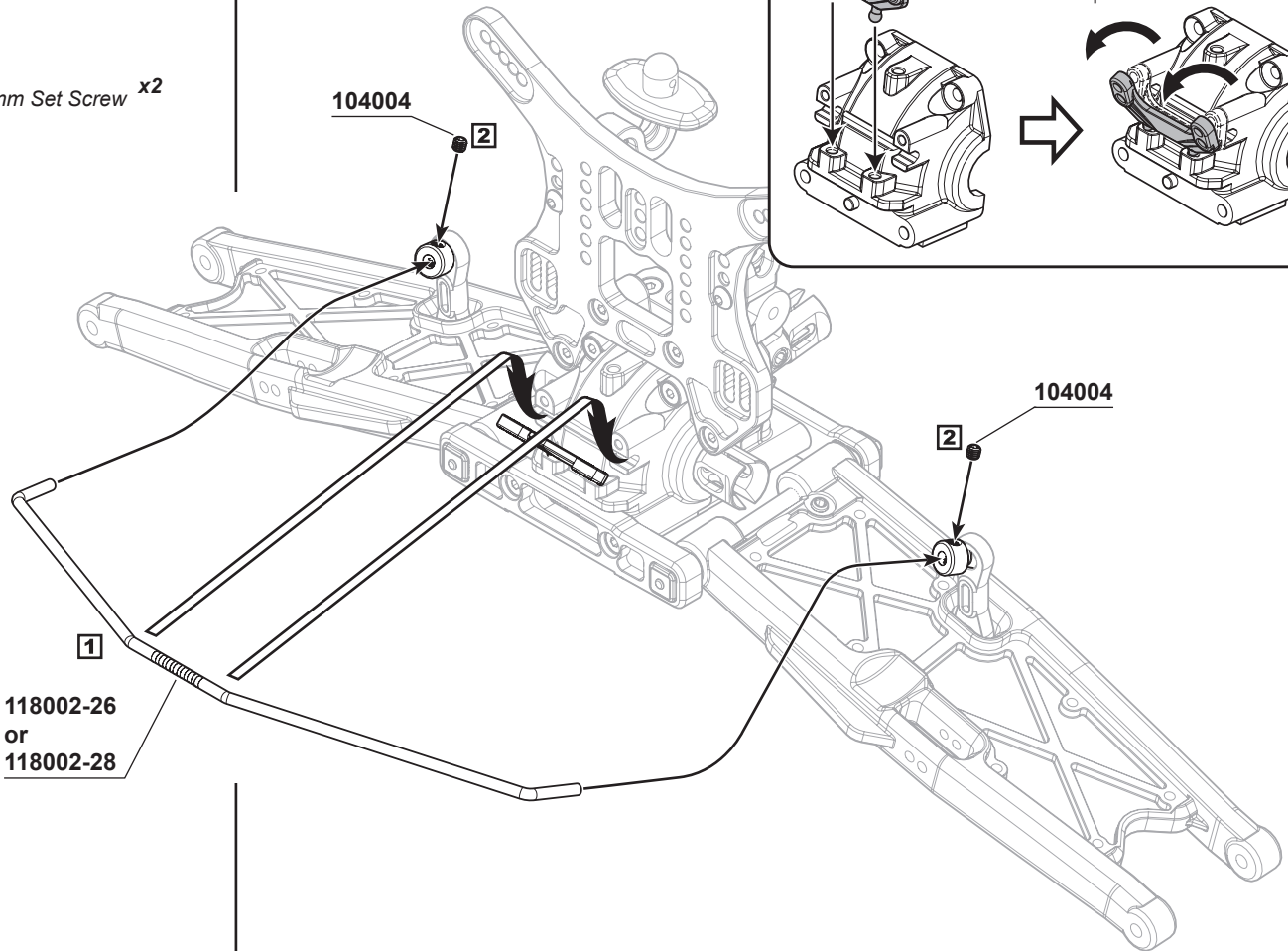

104005  
M3x4mm Set Screw x2



106013  
M2.5x8mmH ex Socket OH/TPScrew x2

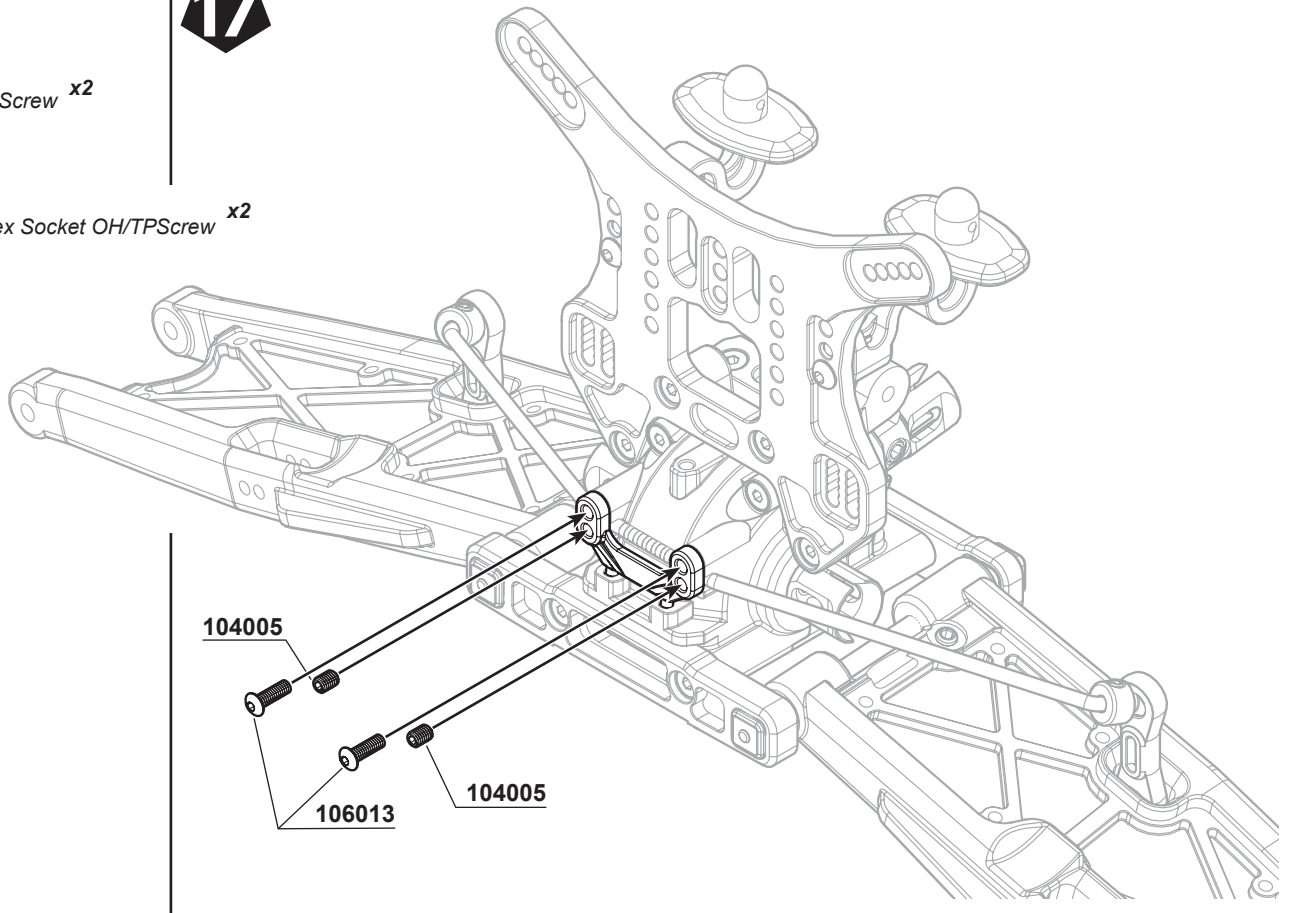



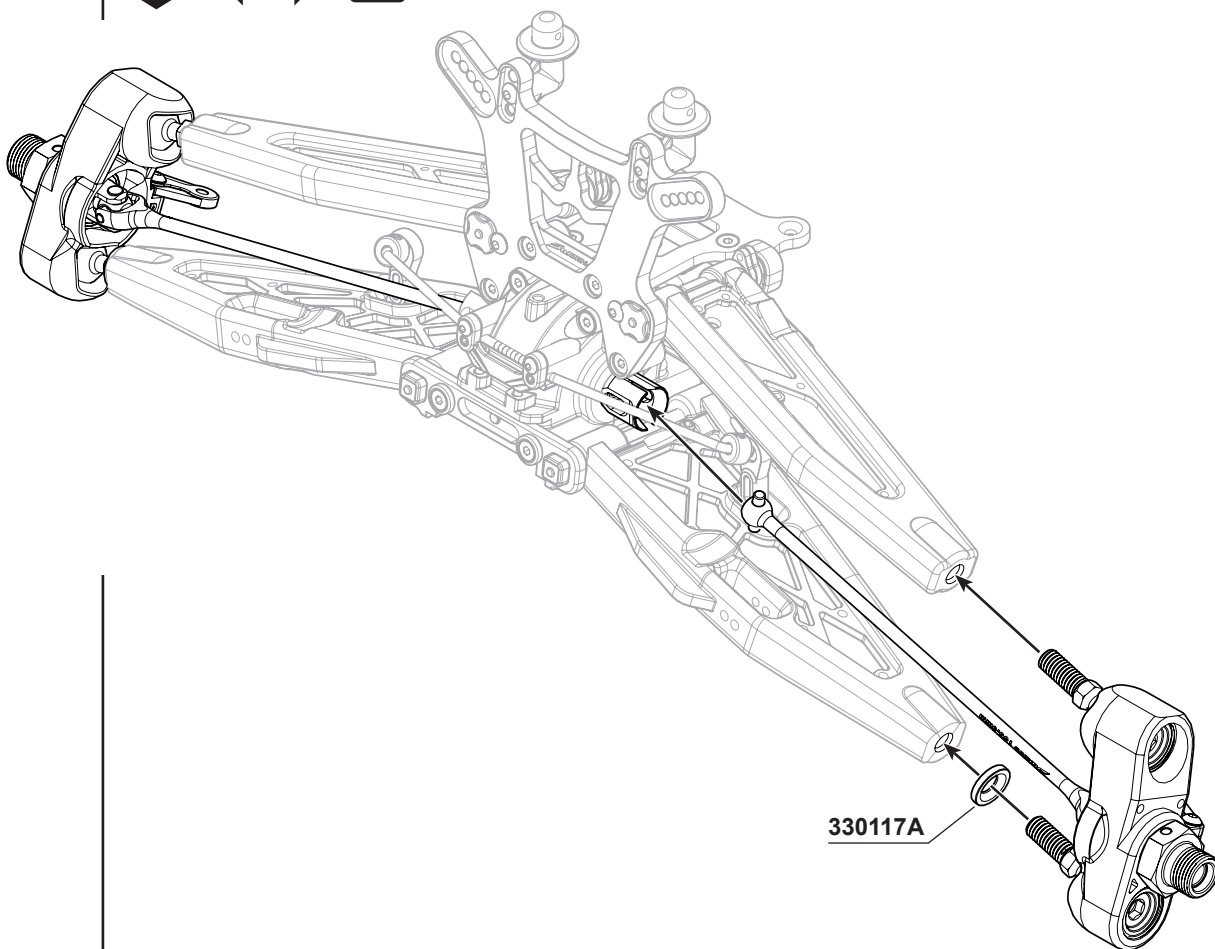

**BAG****E3****20****x2**

330117A

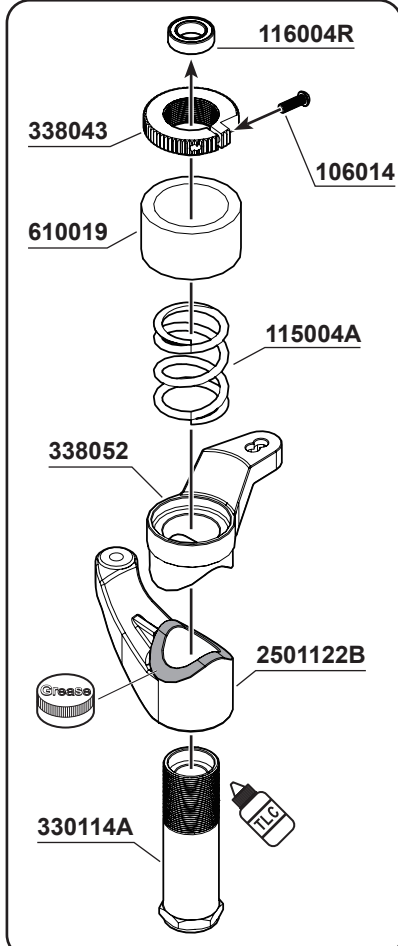
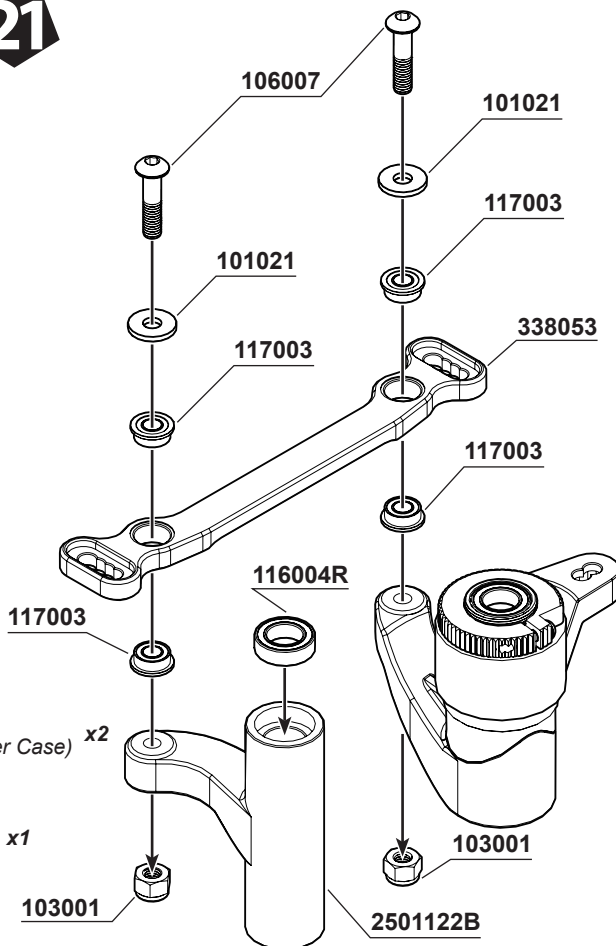
**BAG****E2****21**103001  
M3 Nut Lock x2101021  
M3x8xT1mm x2117003  
Flange Ball Bearing 3x6x2.5mm x4106007  
M3x12mm Hex Socket OH/TP Screw(HT) x2116004R  
Ball Bearing 6x10x3mm (Red Rubber Case) x2106014  
M2x6mm Hex Socket OH/TP Screw x1

# BAG

# E2

# 22



108003  
M3x10mm FH/ST HEX Screw x2



116004R  
Ball Bearing 6x10x3mm (Red Rubber Case) x2



101019  
SHIM 6.0x10.0x0.2mm x1

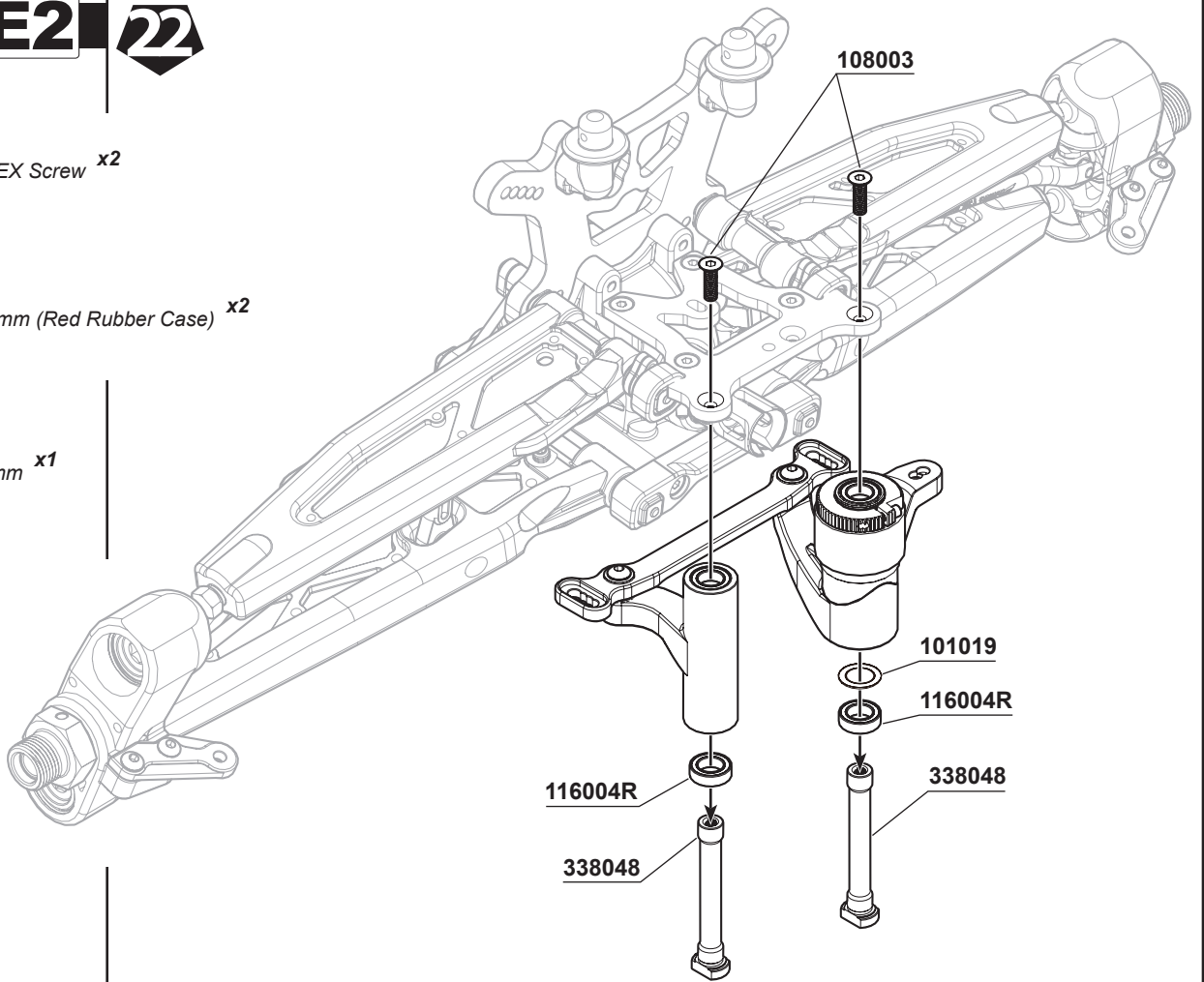

# BAG

# E3

# 23



103001  
M3 Nut Lock x4



104010  
M5x4mm Set Screw (Flat Bottom) x2

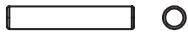

330124  
Pin M3.0x16.8mm x2



106009  
M3x25mm Hex Socket OH/TP Screw x4



116006R  
Ball Bearing 8x16x5mm (Red Rubber Case) x4

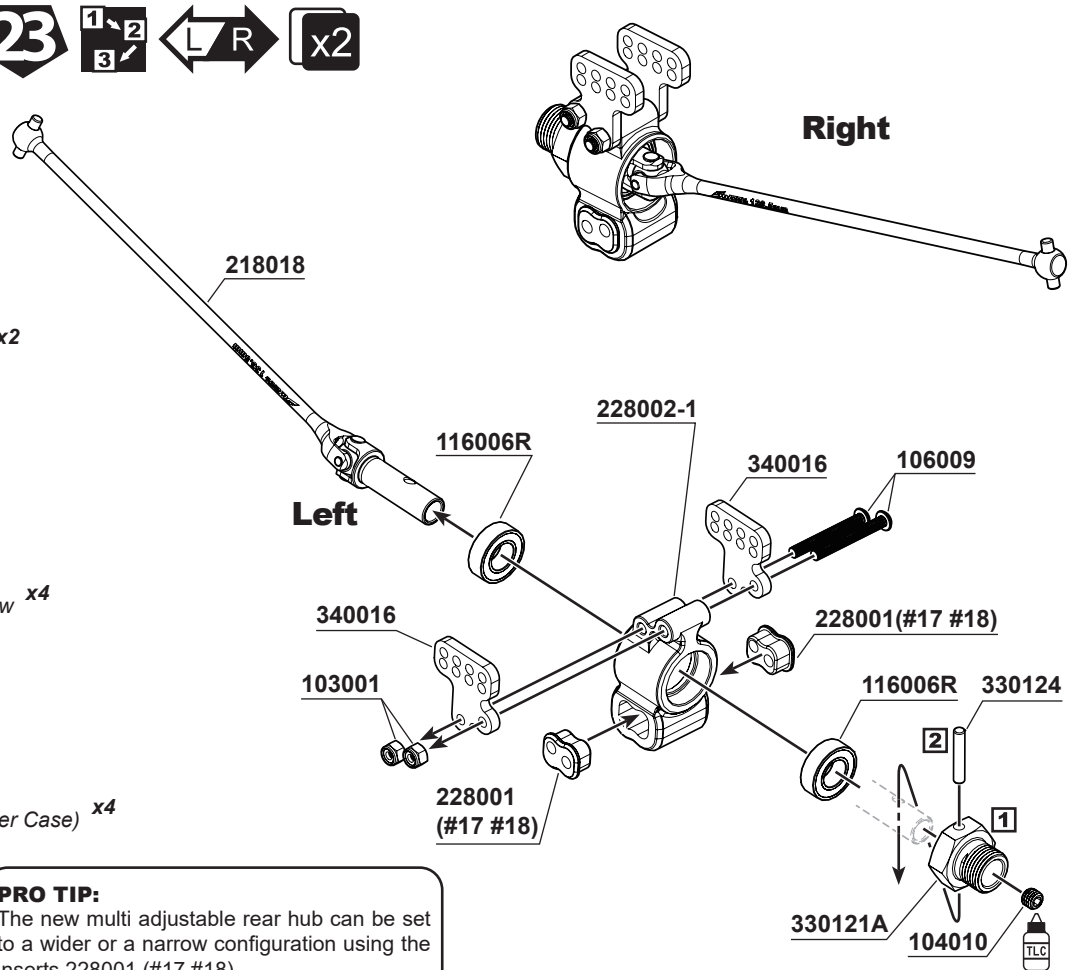

### PRO TIP:

The new multi adjustable rear hub can be set to a wider or a narrow configuration using the inserts 228001 (#17 #18)

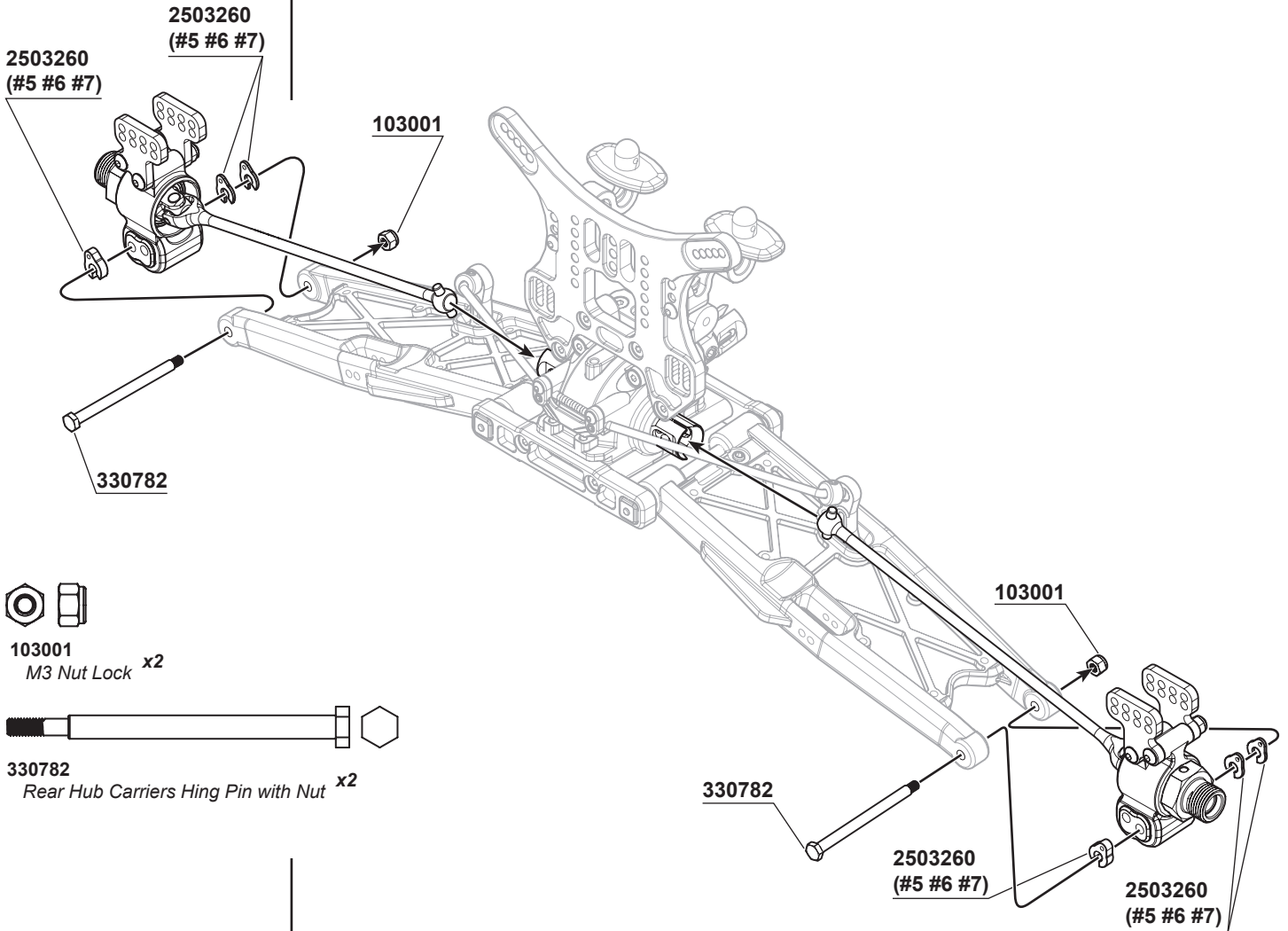

**103001**  
M3 Nut Lock x2

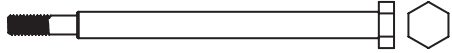

**330782**  
Rear Hub Carriers Hing Pin with Nut x2

**25** **L/R** **x2**

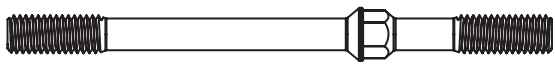
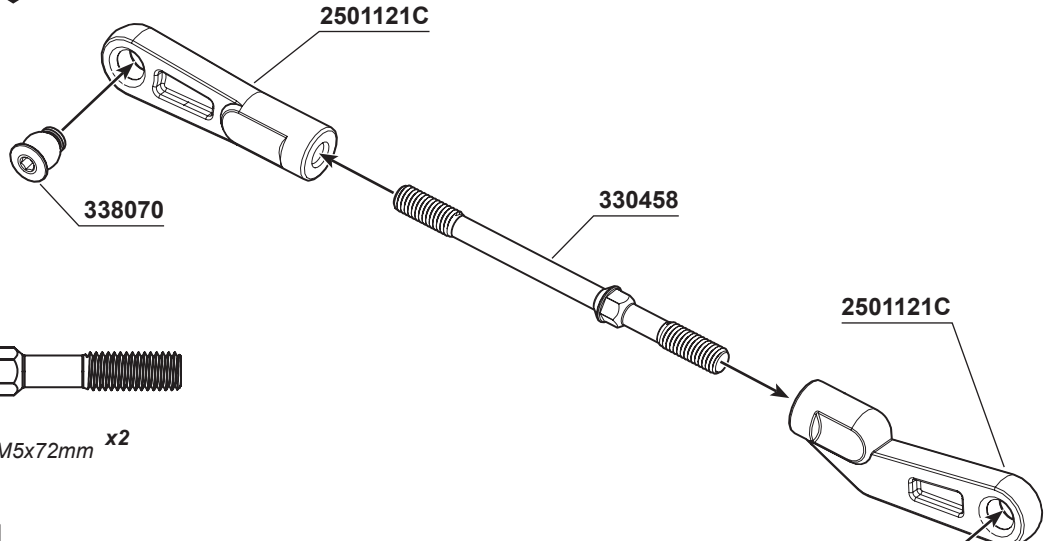

**330458**  
S350T Rear Upper Arm Turnbuckle M5x72mm x2

**1:1**

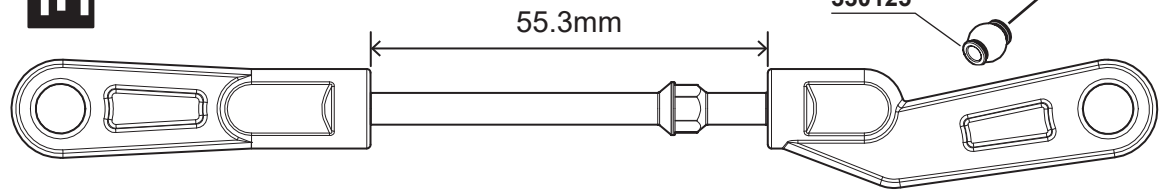



**106002**  
M3x10mm Hex Socket OH/TP Screw x2



**106009**  
M3x25mm Hex Socket OH/TP Screw x2



**103001**  
M3 Nut Lock x2

**106009**

**228001**

**106002**

**103001**



**106003**  
M3x16mm Hex Socket OH/TP Screw x4



**103001**  
M3 Nut Lock x4



**108019**  
M2.6x6mm Flat Head Screw - Hex Socket x2

**103001**

**228003A**

**228003A(#3)**

**108019**

**228003A(#3)**

**228003A**

**228003A**

**106003**



**106007**  
M3x12mm Hex Socket OH/TP Screw(HT) x4



**104004**  
M3x3mm Set Screw x2



**108006**  
M3x8mm FH/ST HEX Screw x4



**116009**  
Ball Bearing M5x8x2.5mm x2

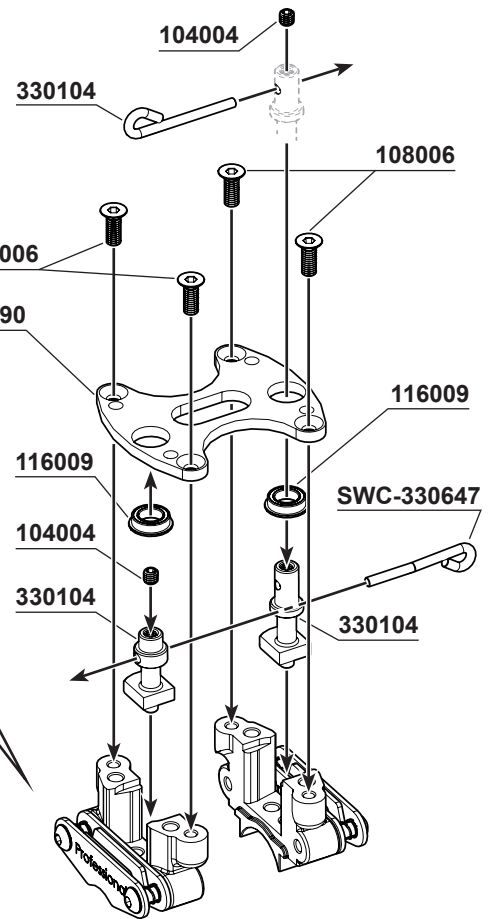
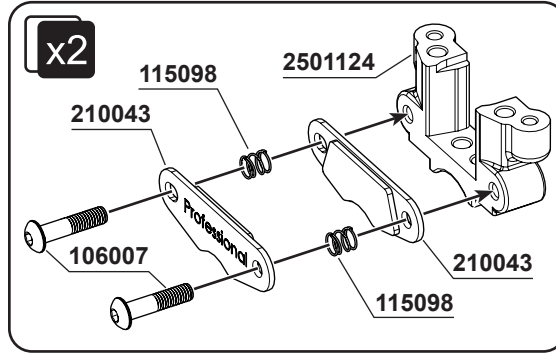

**106009**  
M3x25mm Hex Socket OH/TP Screw x4

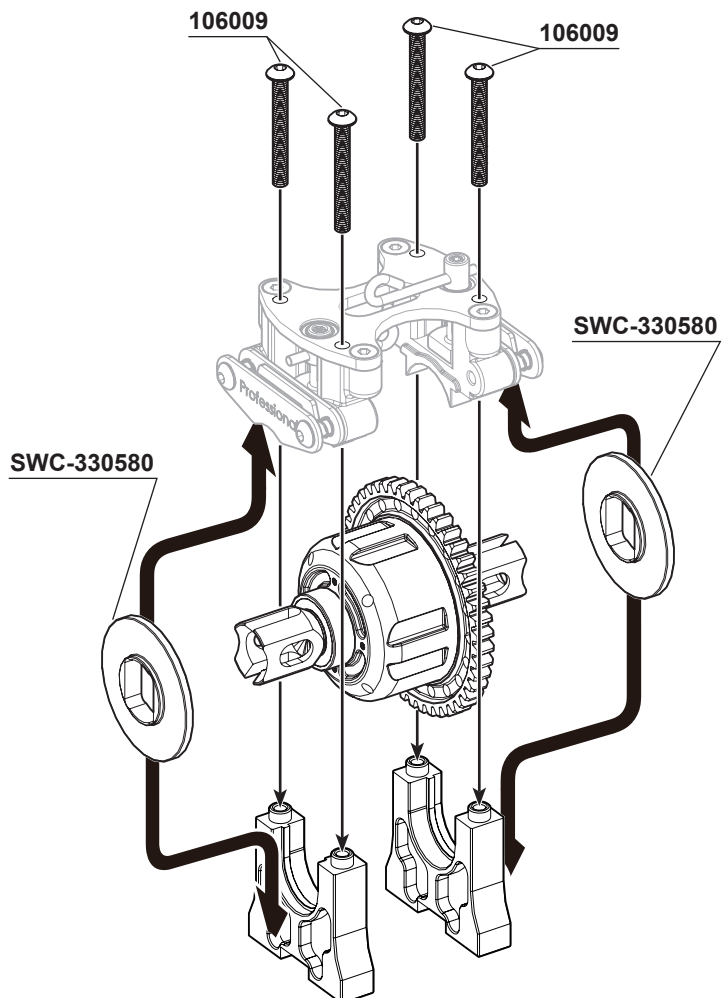



**108007**  
M3x6mm FH/ST HEX Screw x10

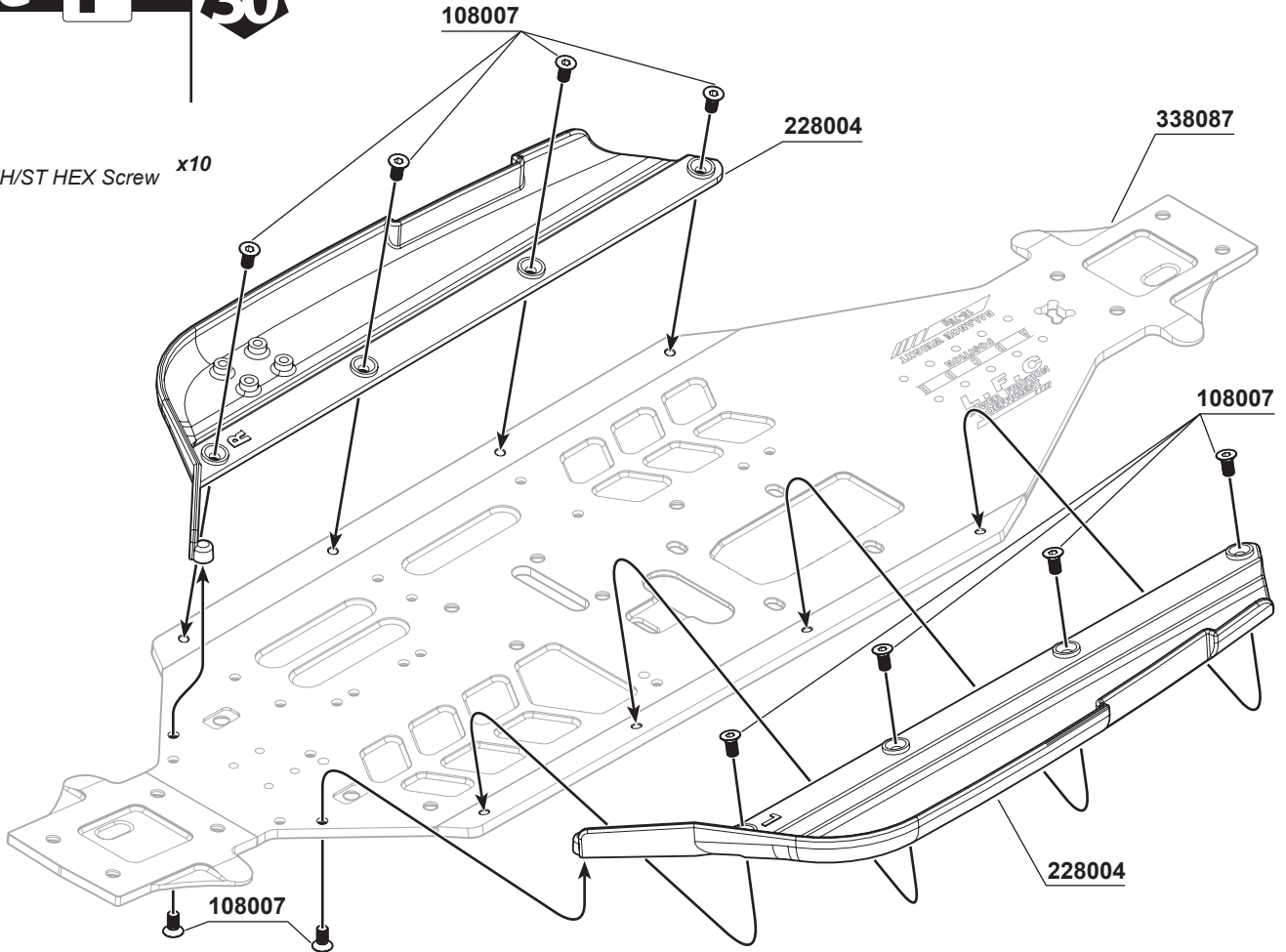

**108003**  
M3x10mm FH/ST HEX Screw x2



**108010**  
M4x10mm FH/ST HEX Screw x2



**108012**  
M4x16mm FH/ST HEX Screw x4

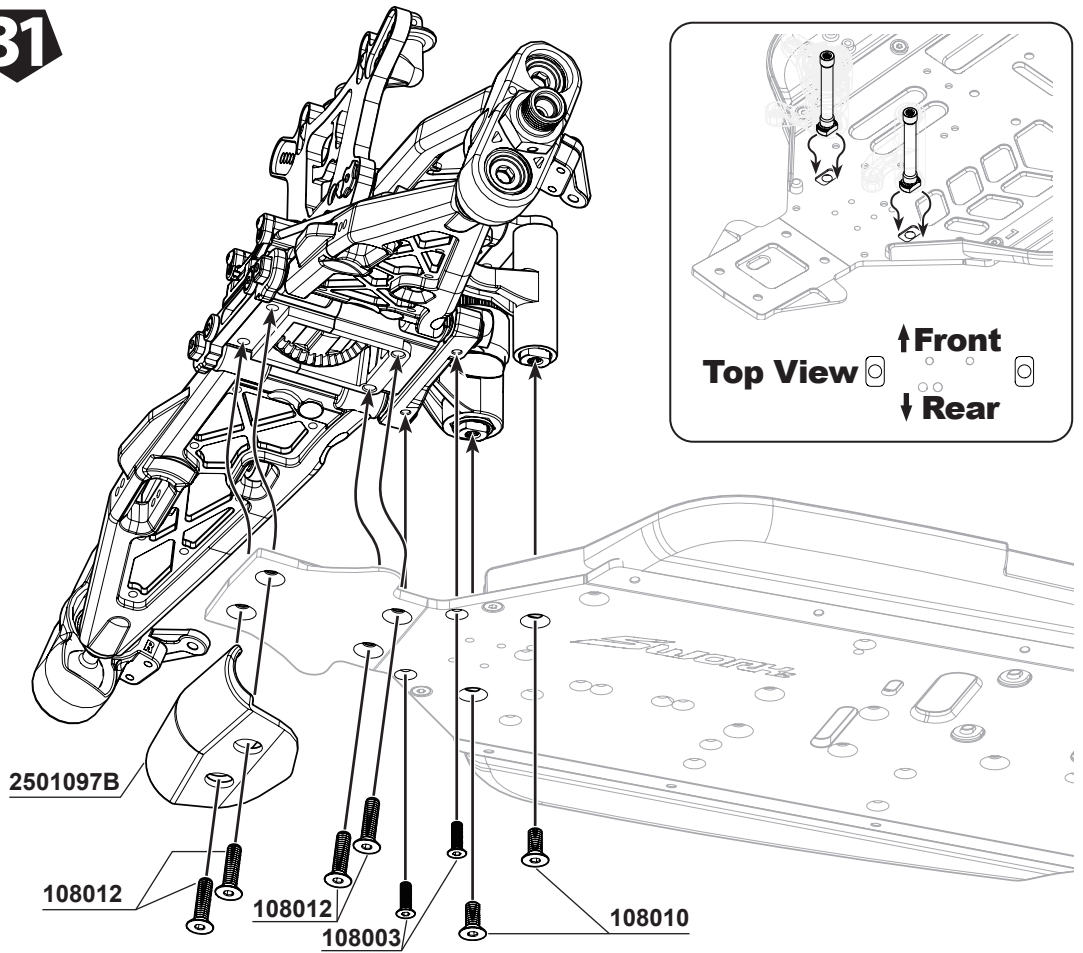



**108003**  
M3x10mm FH/ST HEX Screw x3

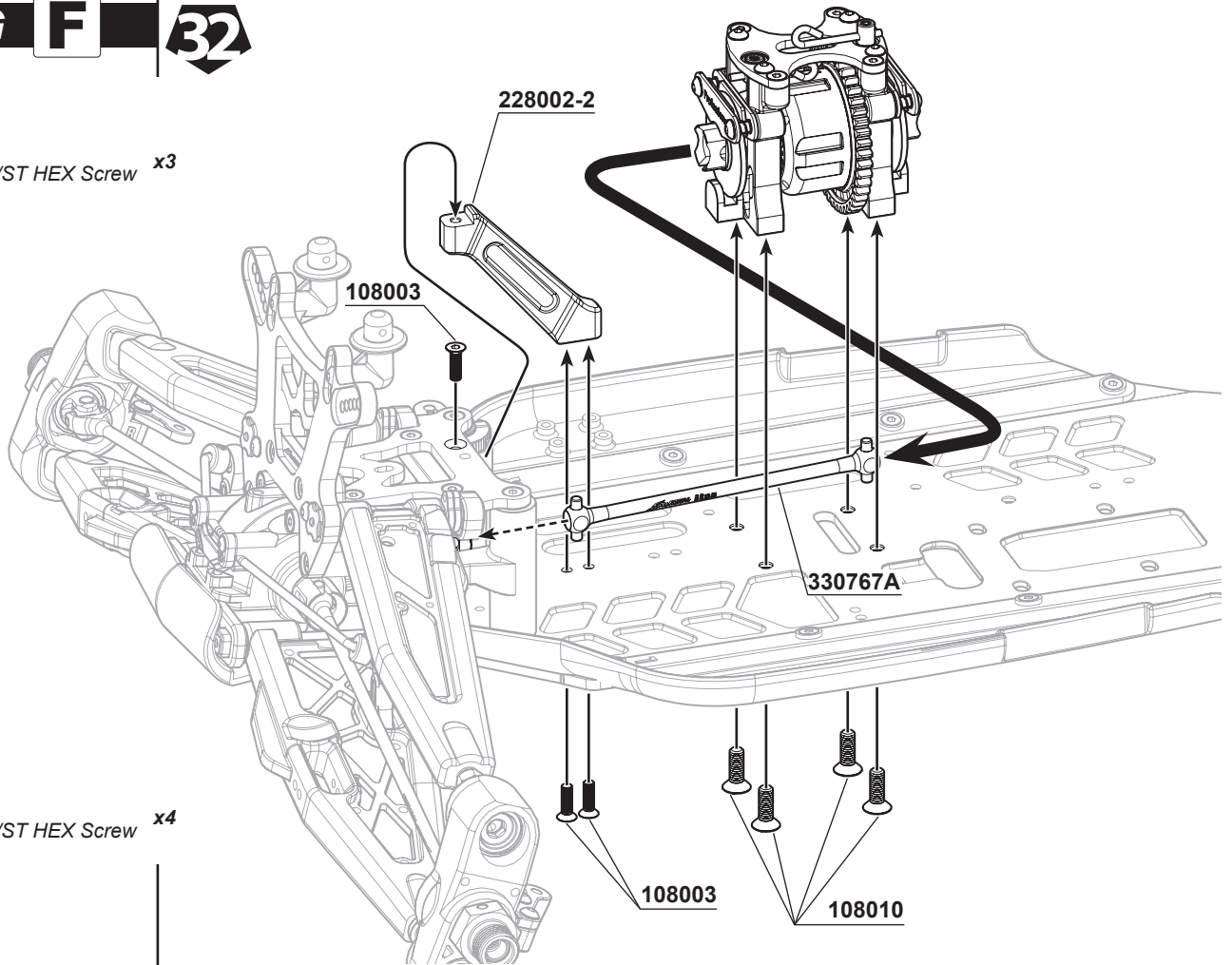

**108010**  
M4x10mm FH/ST HEX Screw x4



**108011**  
M4x12mm FH/ST HEX Screw x1



**108012**  
M4x16mm FH/ST HEX Screw x4



**106006**  
M3x20mm Hex Socket OH/TP Screw x1



**103001**  
M3 Nut Lock x1



**103005**  
M4mm Nut Lock (BK) x1

**33**

- 1
- 2
- 3

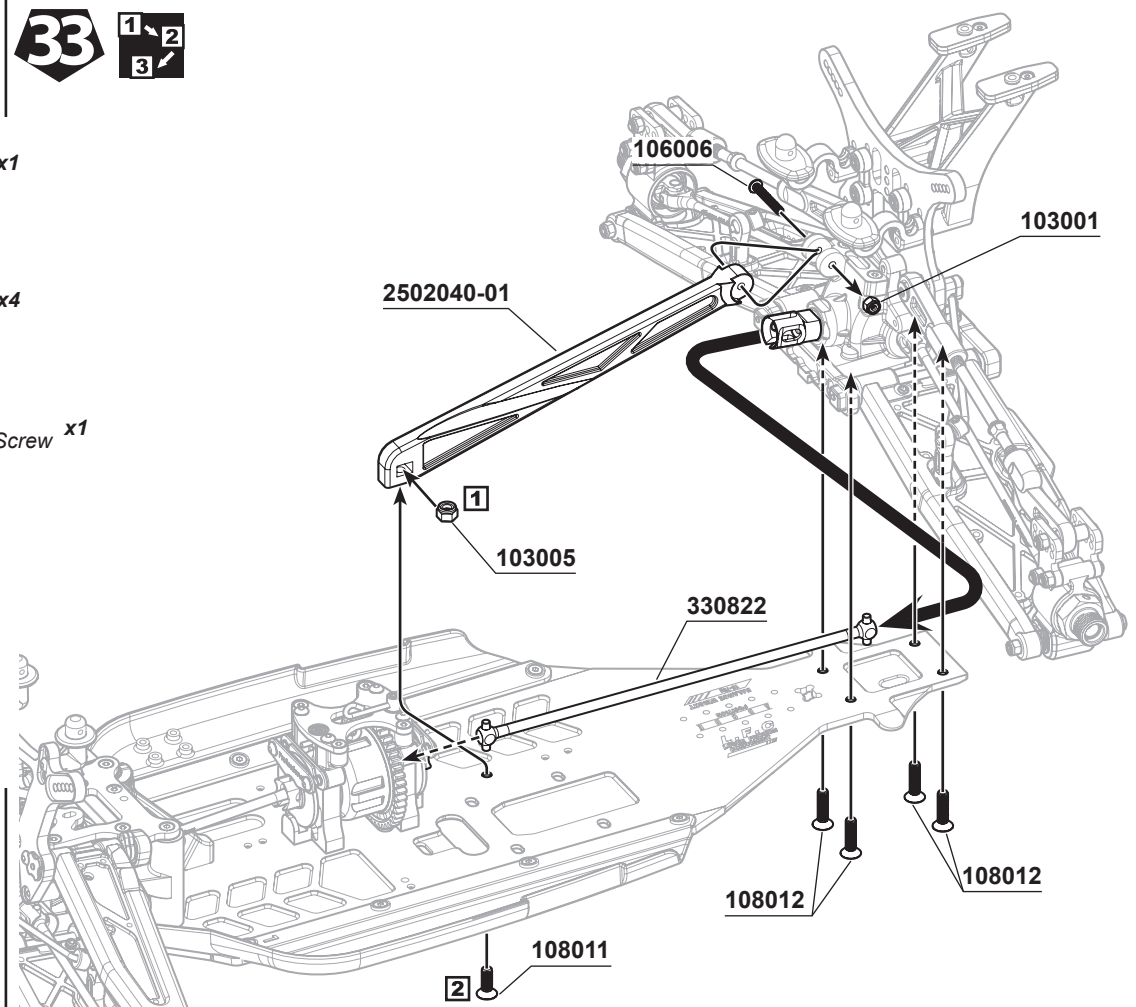

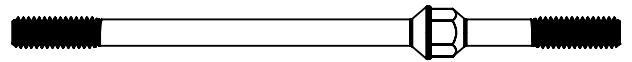

**338089**  
Steering Linkage Turnbuckle M4x80mm x2

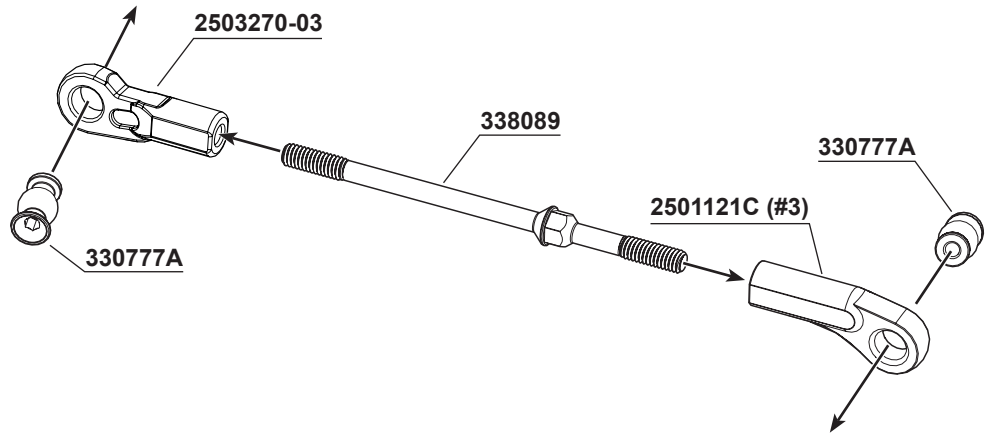

**1:1**

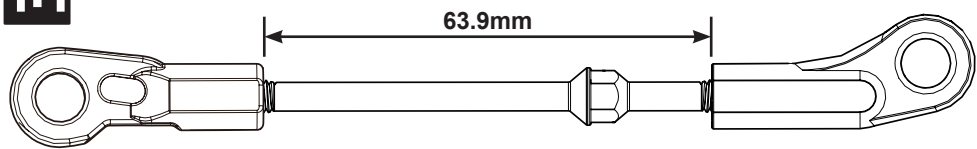

**106002**  
M3x10mm Hex Socket OH/TP Screw x4

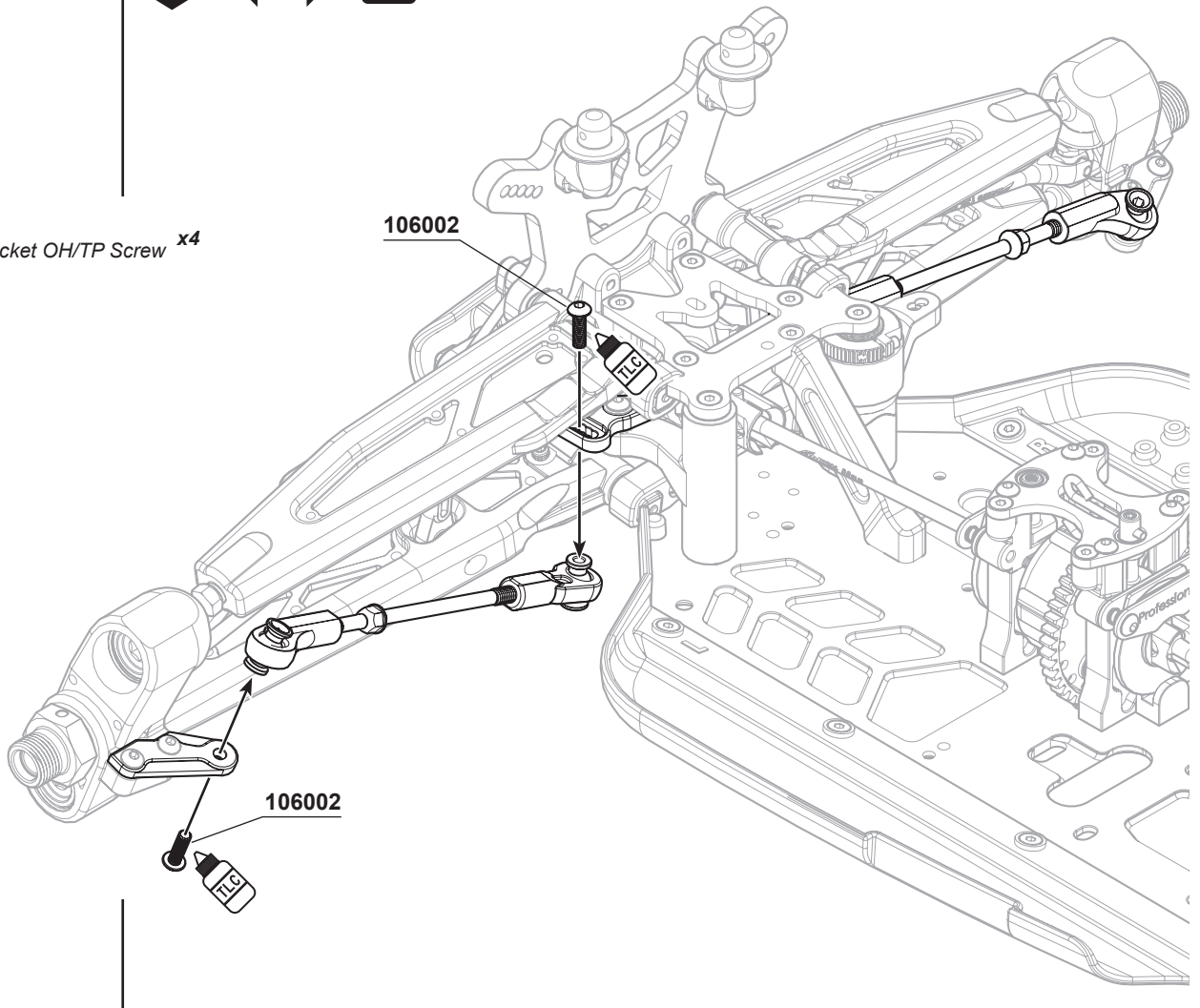





**106008**  
M3x12mm Hex Scket OH/TP Screw x4



**106003**  
M3x16mm Hex Scket OH/TP Screw x4

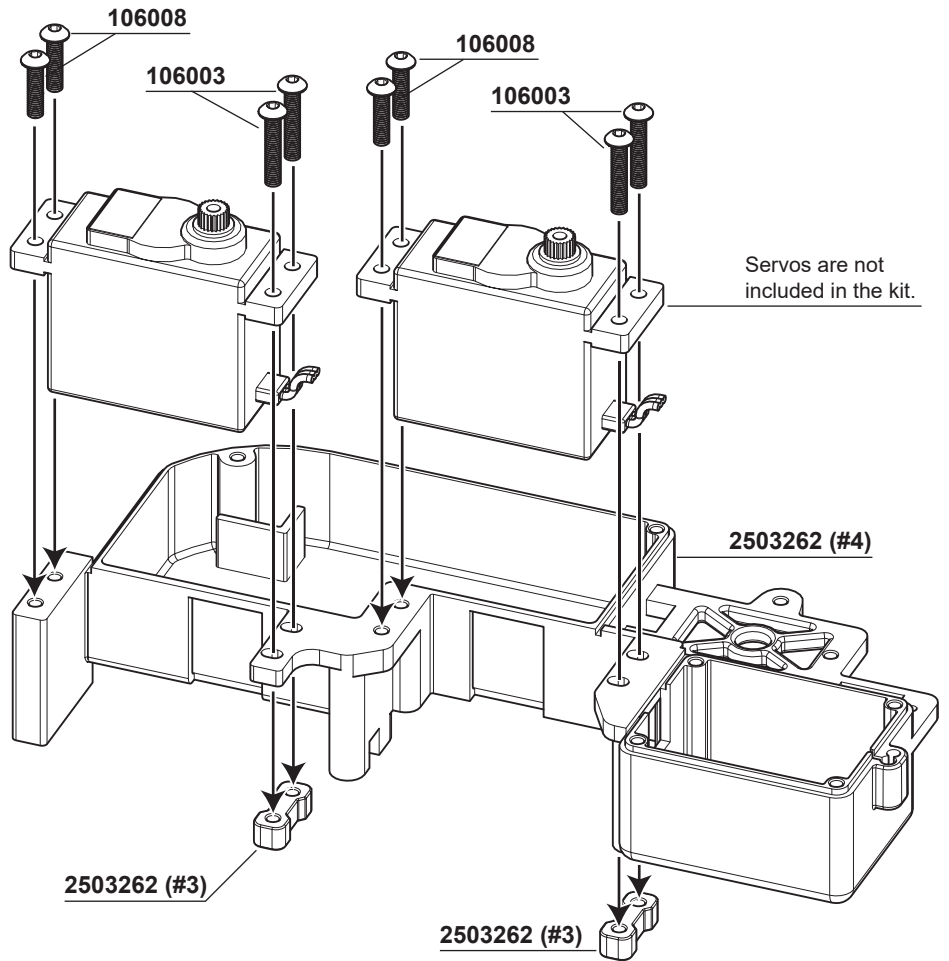

**103001**  
M3 Nut Lock x2



**106002**  
M3x10mm Hex Scket OH/TP Screw x3

Receiver and switch are not included in the kit.

The switch is not included in the kit.

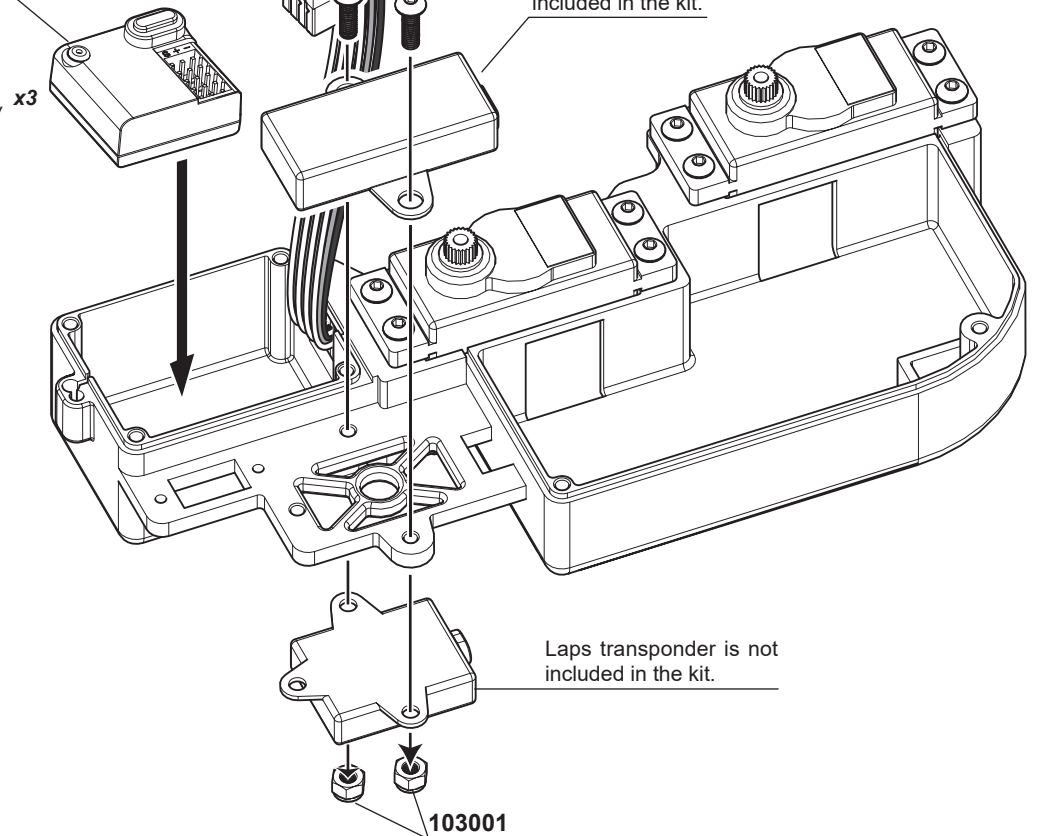



**108006**  
M3x8mm FH/ST HEX Screw x4

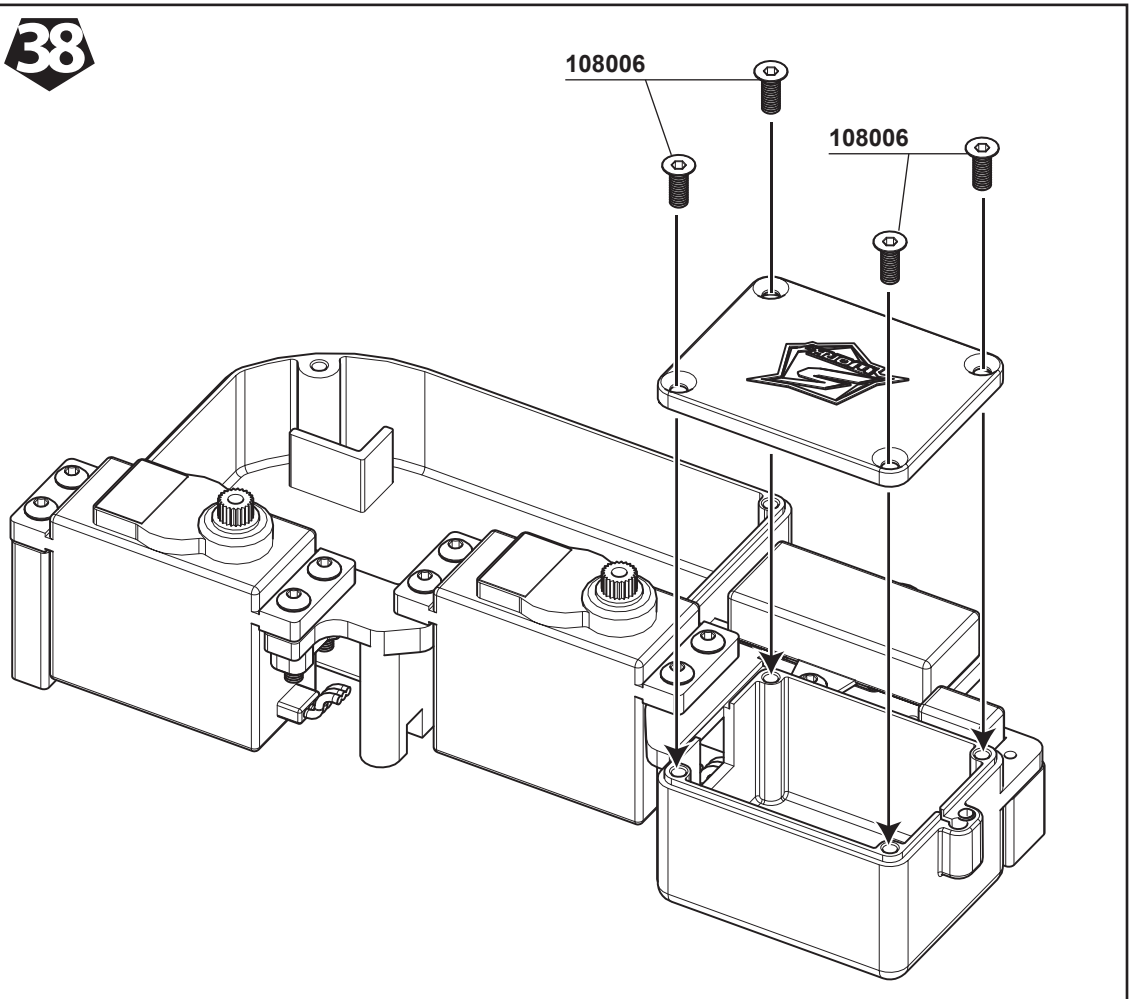

**104004**  
M3x3mm Set Screw x1



**106001**  
M3x8mm Hex Socket OH/TP Screw x3

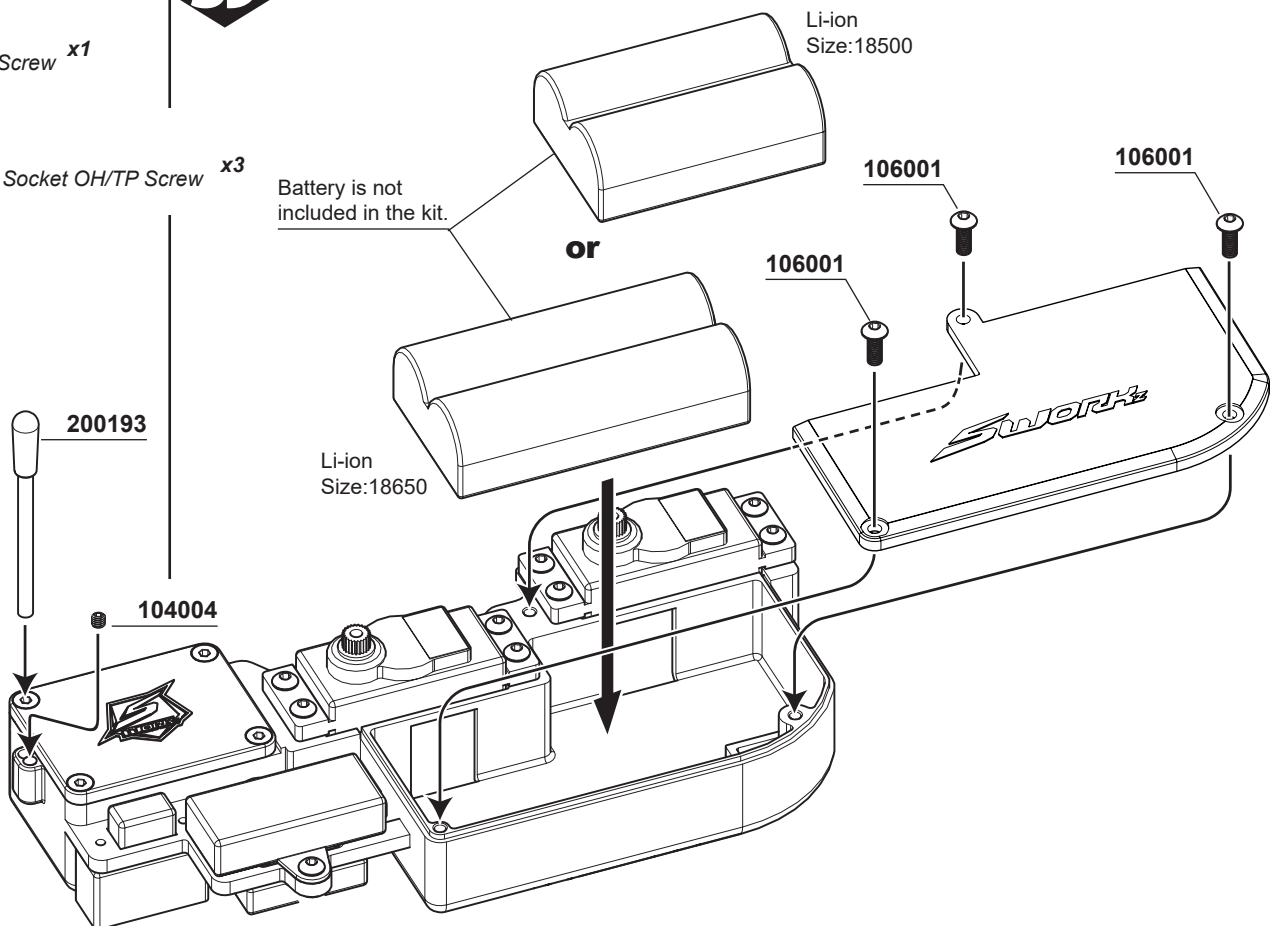

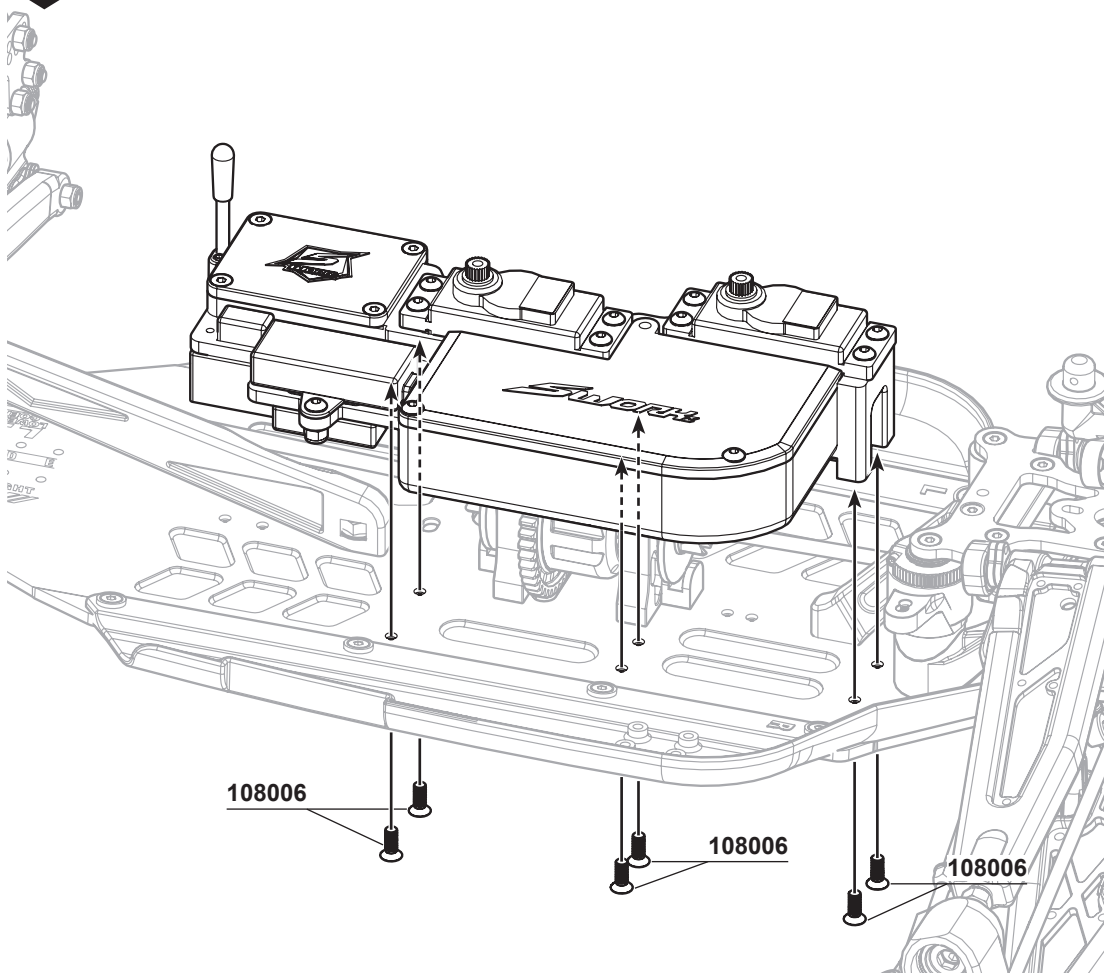

**108006**  
M3x8mm FH/ST HEX Screw x6

108006

108006

108006

**OPTION:**  
SW-338078-25 SWORKz Uni-Design 2-Way System Aluminum Steering Servo Horn 25T  
SW-338078-23 SWORKz Uni-Design 2-Way System Aluminum Steering Servo Horn 23T



**106007**  
M3x12mm Hex Socket OH/TP Screw (HT) x1



**330155**  
Steering Servo Turnbuckle (M3x30mm) x1



**103001**  
M3 Nut Lock x1

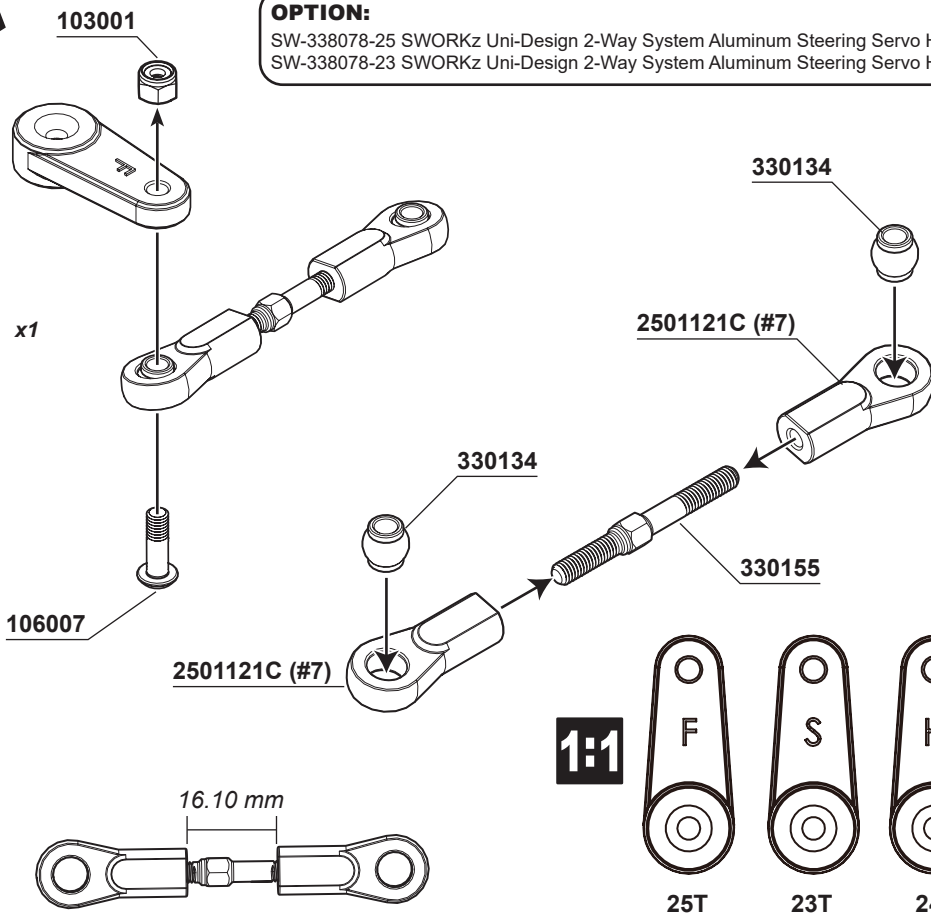

**1:1**

25T

23T

24T

# BAG G

## 42



**108006**  
M3x8mm FH/ST HEX Screw x1



**106007**  
M3x12mm Hex Socket OH/TP Screw (HT) x1



**103001**  
M3 Nut Lock x1

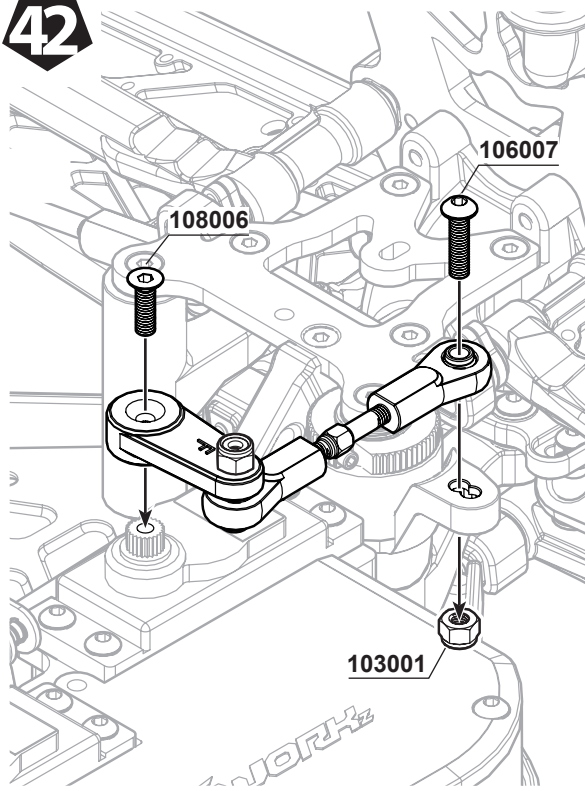

**SW-338052**  
S35-4 Series T7 Aluminum Setting Bellcrank Upper Part-A (with 2Hole )

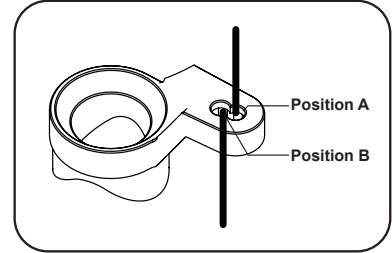

If servo saver arms are not included use this:

**Position A:** Standard steering response location. Use of a 2.5mm longer servo saver arm is required.

If servo saver arms are included use this:

**Position A:** Standard steering response location. Use of the included 2.5mm longer servo saver arm is required.

**Position B:** Quick steering response location. Standard servo saver arm can be used.

# BAG H

## 43



**108006**  
M3x8mm FH/ST HEX Screw x2



**106020**  
M2.5x5mm Hex Socket OH/TP Screw x3



**106002**  
M3x10mm Hex Socket OH/TP Screw x3

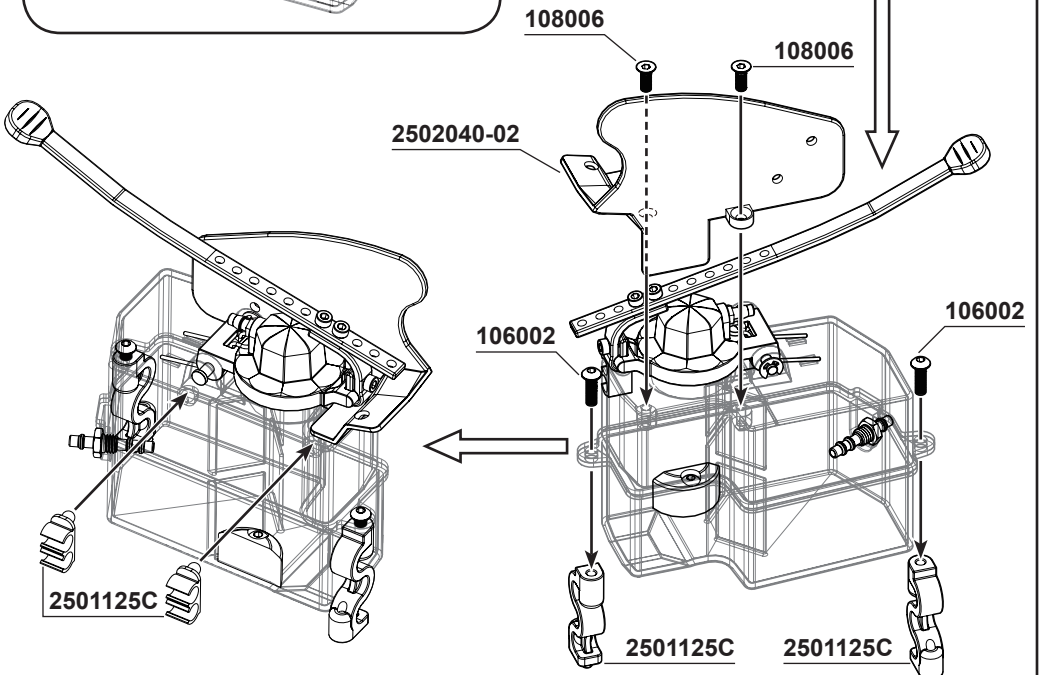
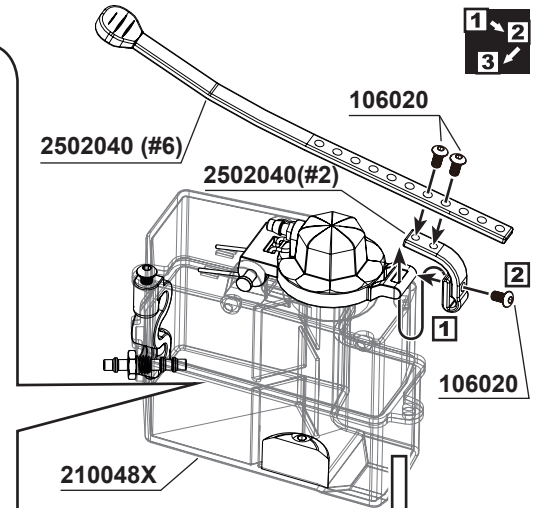
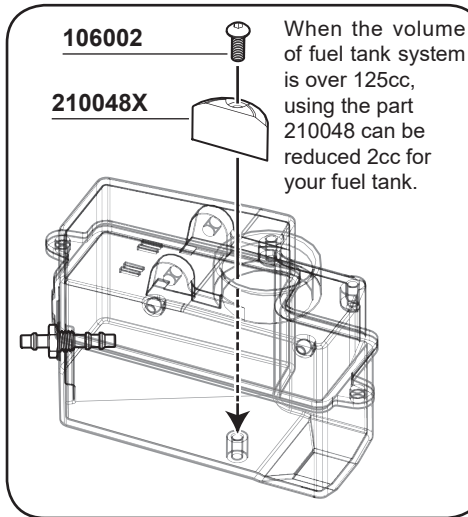

# BAG H

## 44



108003  
M3x10mm FH/ST HEX Screw x2

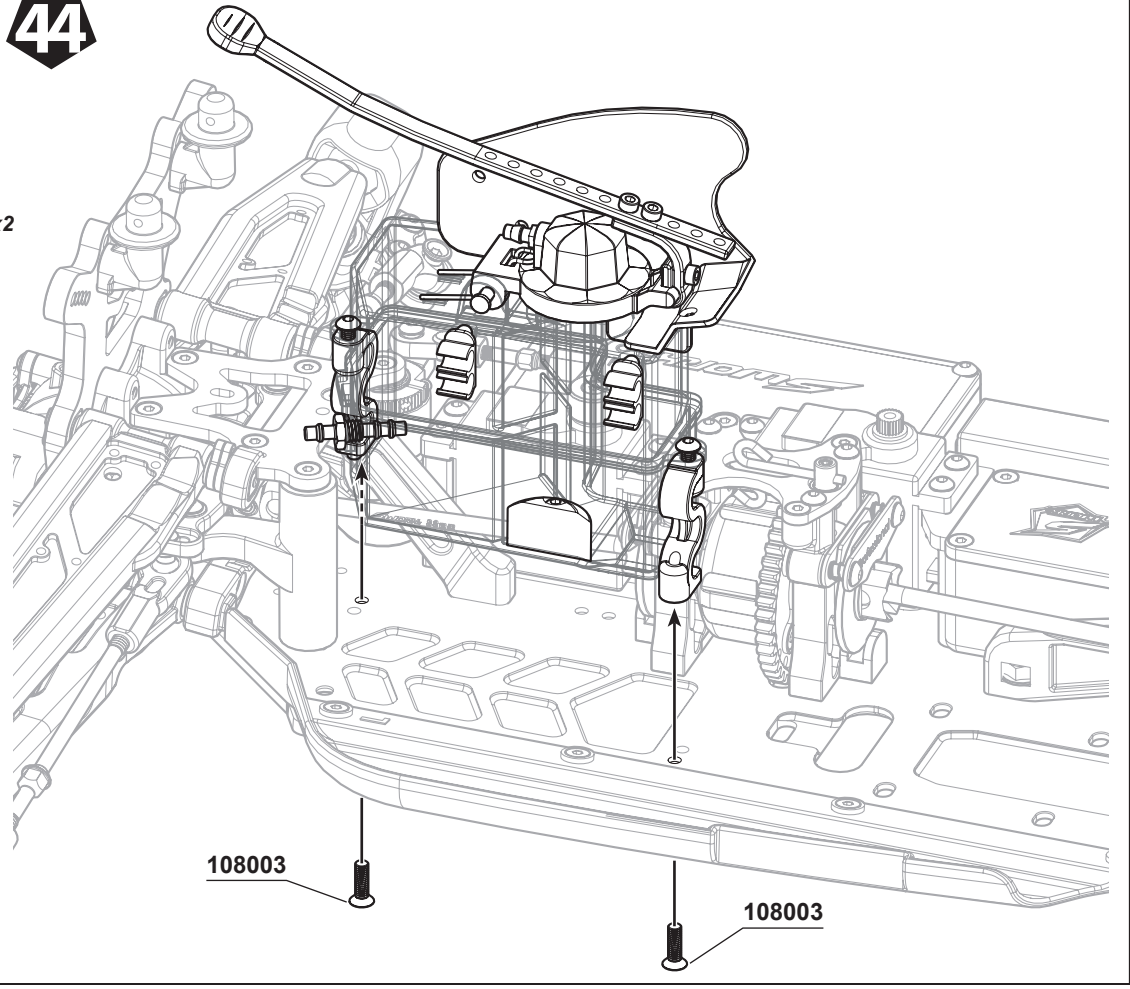

# BAG I

## 45





105005  
M3x12mm Cap Screw x4

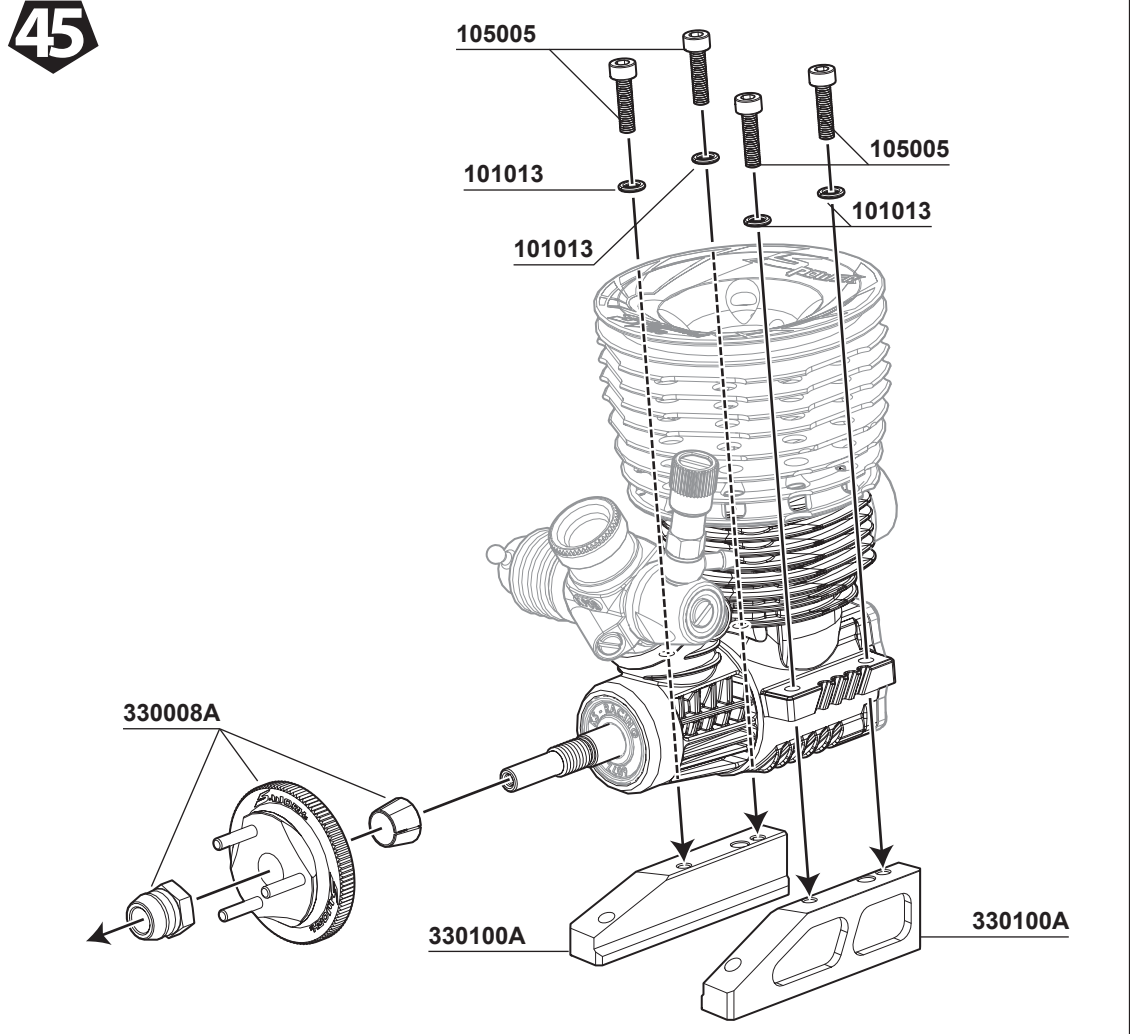

101013  
3mm Spring Washer x4



 **105001**  
M3x8mm Cap Screw x1

 **101021**  
M3x8xT0.8mm x1

 **101015**  
M5x8xT0.4mm x2

 **101016**  
M5x8xT0.8mm x3

**116010R**  
Ball Bearing 5x10x4mm (Red Rubber Case) x2

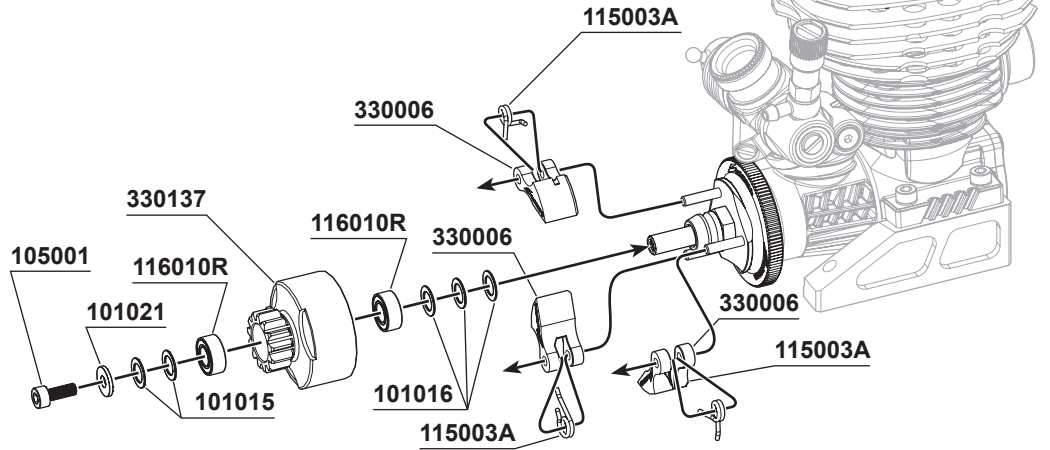

 **105007A**  
M4x8mm I-Head Screw x4

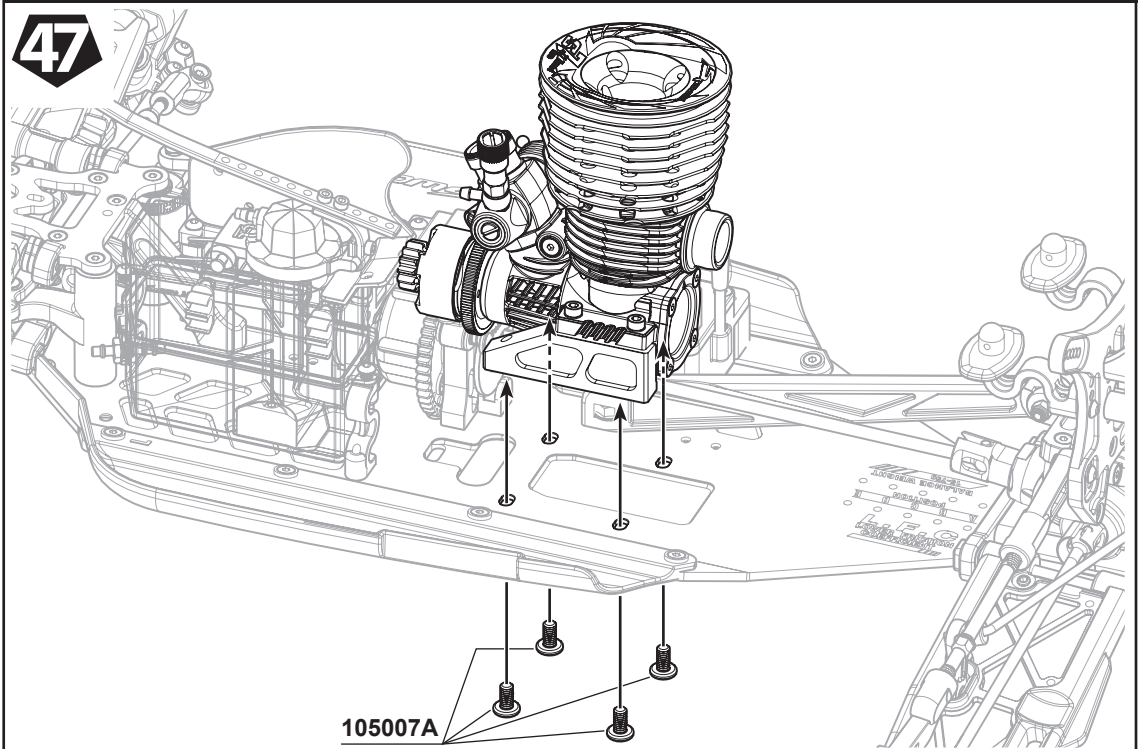

 **104011**  
M4x4mm Set Screw (Flat Bottom) x2

 **108013**  
M4x8mm FH/ST HEX Screw x1

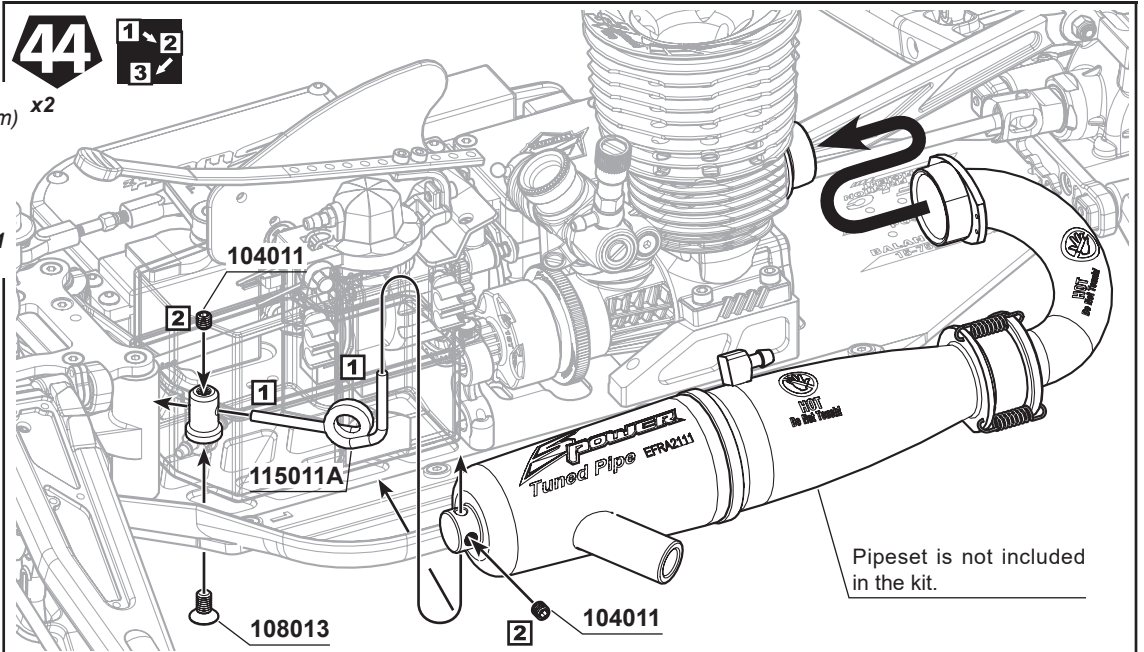

104004  
M3x3mm Set Screw x6



106007  
M3x12mm Hex Socket OH/TP Screw(HT) x1

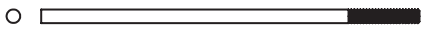

210018  
Throttle Rod 50mm x1

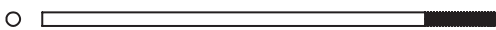

210018  
Throttle Rod 60mm x2



330157A  
Brake Adjuster Knob x2



106020  
M2.5x5mm Hex Socket OH/TP Screw x3



108006  
M3x8mm FH/ST HEX Screw x1



330156A  
Adjuster Knob x4



115015  
Brake Spring x2



115017  
Throttle Rod Spring x1

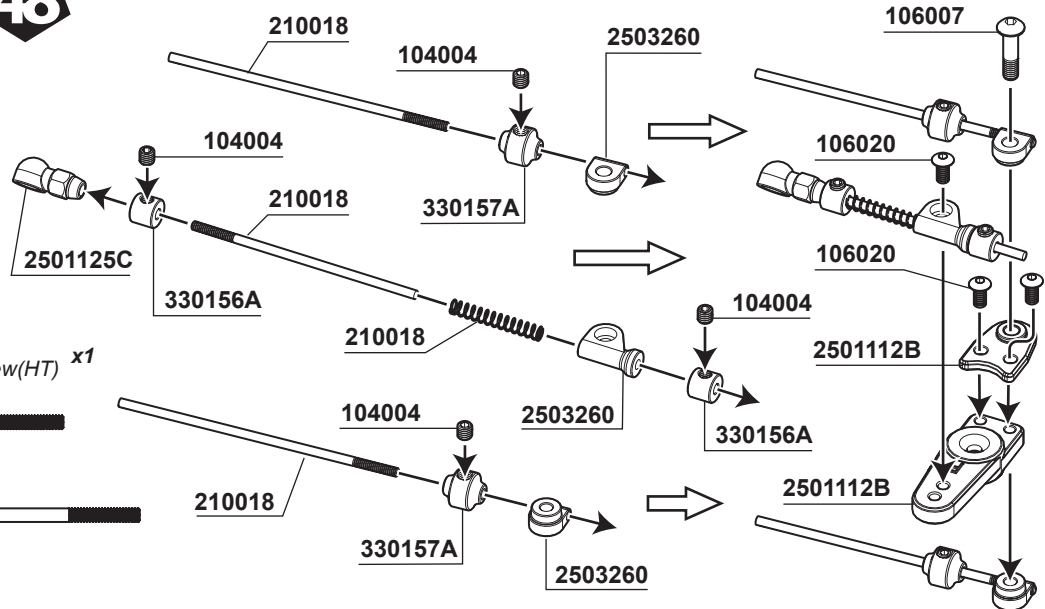

**OPTION:**

SW-338079-25 SWORKz Uni-Design Aluminum Throttle Servo Horn 25T  
SW-338079-23 SWORKz Uni-Design Aluminum Throttle Servo Horn 23T

104004

330156A

210018

2503260

108006

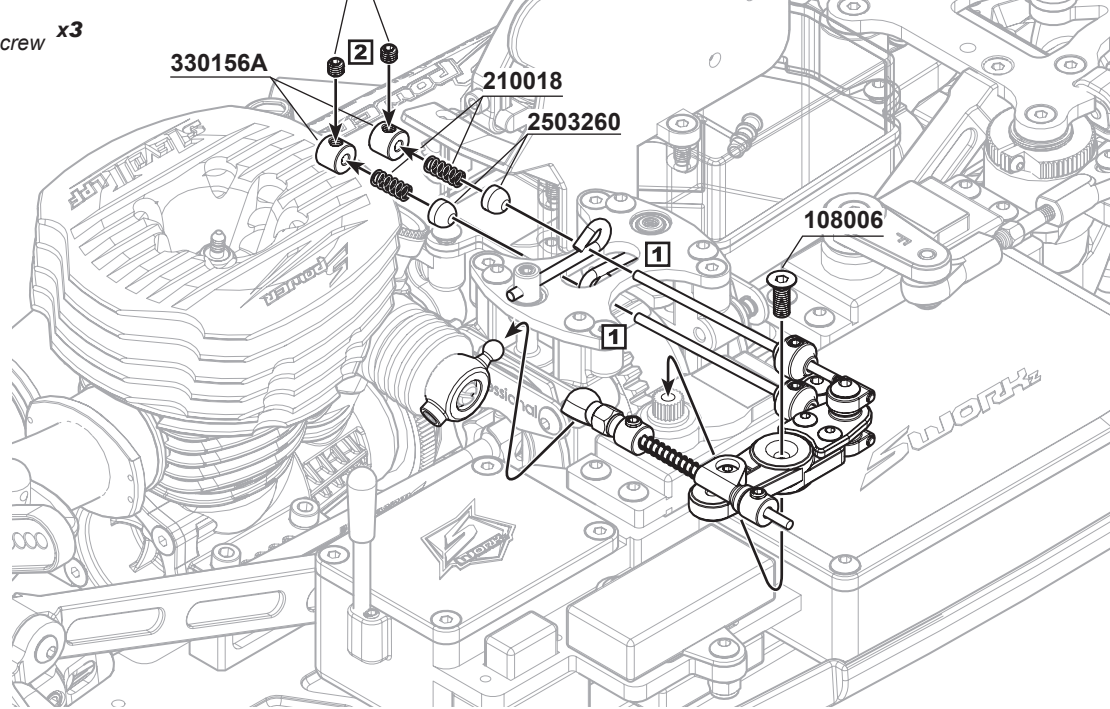

**Linkage Adjustment**

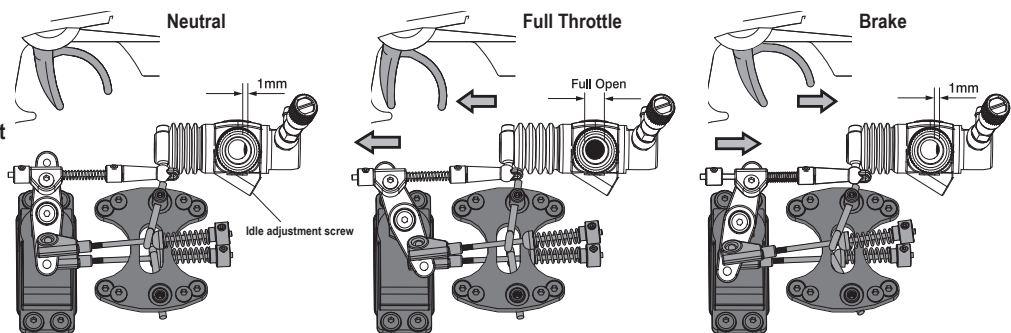

※ Turn on the transmitter and receiver. Set the throttle servo trim in neutral. Adjust the idle adjustment screw to make the carburettor opening no more than 1mm. Adjust the position of servo horn. Check that it operates smoothly without making the operation of the other parts difficult. Make sure the brake does not work in this setting.

※ Adjust the servo horn to fully open the carburettor. Change the position of servo horn if the carburettor is not fully open or opens too much. If your transmitter has a function to adjust throttle end points, make an adjustment this way.

※ Adjust the position of servo horn to make the brakes function. Make sure the brakes do not work when the servo trim is in neutral.

330635(L)  
S350 New BBS System +5.5mm Shock Shaft ( L ) x2

330636(S)  
S350 New BBS System +1.3mm x2  
Shock Shaft ( S )

103004  
M2.5mm Nut Lock x4

210058  
Shock Seal Washer 3.5X7X1.0mm x4

210058  
Shock Seal Washer 3.6X7X2.5mm x8

101011  
M2.6x6xT0.6mm x4

210058  
Shock Seal O-Ring x8

400020  
Shock Seal O-Ring x4

400019  
Shock Spring Adjust  
Nut O-Ring x4

108029  
M2.0x4.6mm FH/ST  
HEX Screw (1.5mm HexHead) x4

Front 338634(S)  
Rear 338633(L)

103004  
330562A  
330563A  
101011

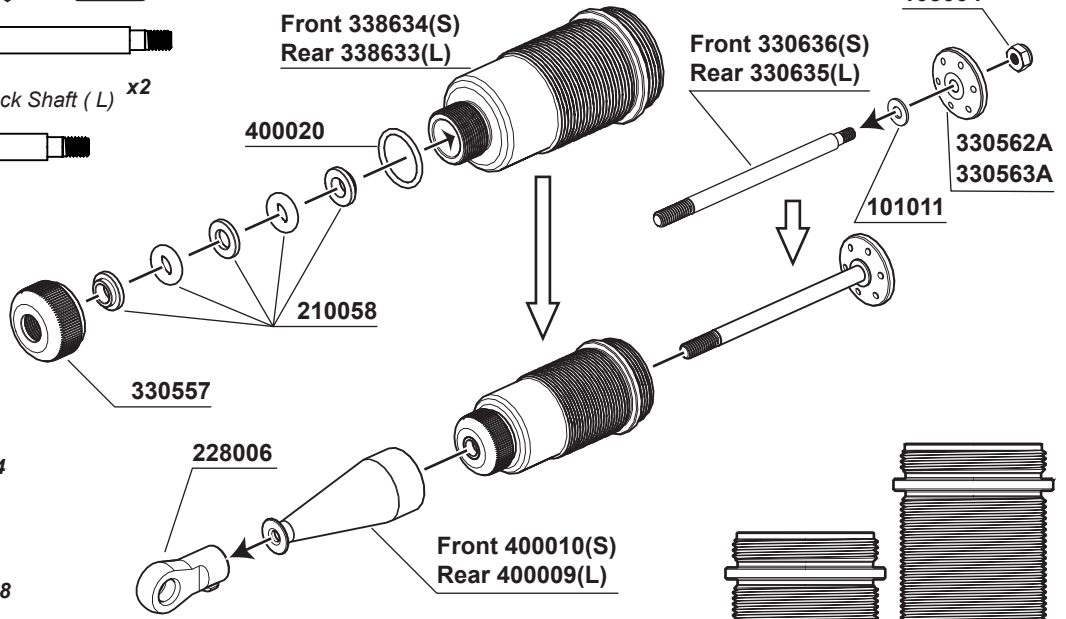

**52**

**Standard bladder shock cap assembly note**

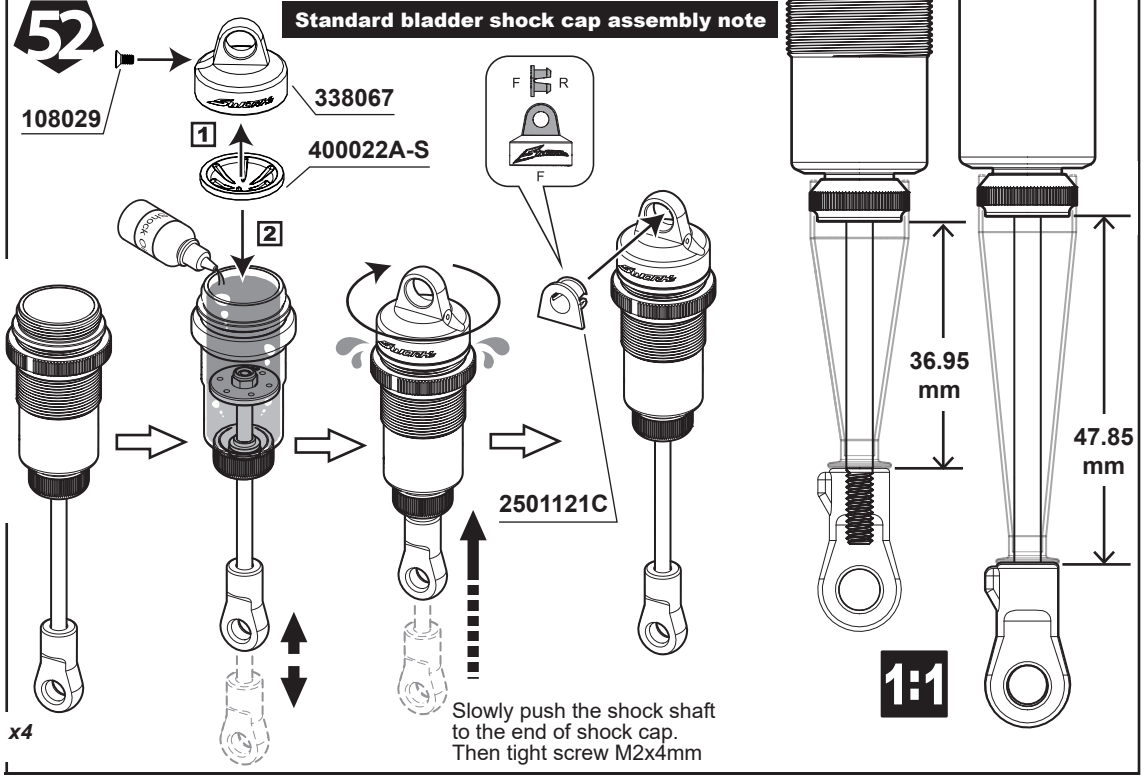

Slowly push the shock shaft to the end of shock cap. Then tight screw M2x4mm

**53**

115170  
S350 BBS Option Shock  
SpringB-1(90X1.4X7.5) x2

115168  
S350 BBS Option Shock  
SpringA-1(75X1.4X6.5) x2

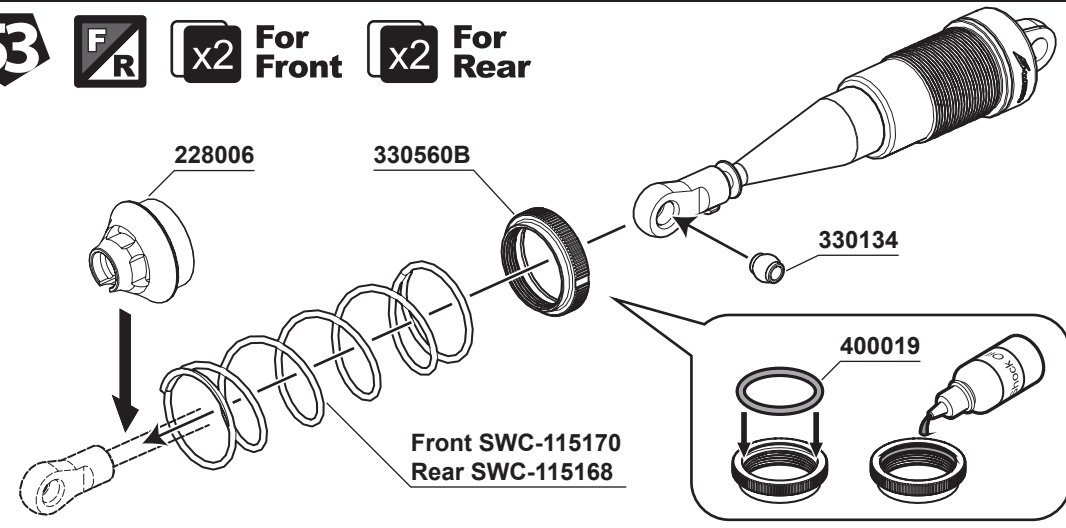

Front SWC-115170  
Rear SWC-115168



**330635(L)**  
S350 New BBS System +5.5mm Shock Shaft ( L ) x2

**330636(S)**  
S350 New BBS System +1.3mm Shock Shaft ( S ) x2

**103004**  
M2.5mm Nut Lock x4

**210058**  
Shock Seal Washer 3.5X7X1.0mm x4

**210058**  
Shock Seal Washer 3.6X7X2.5mm x8

**101011**  
M2.6x6xT0.6mm x4

**210058**  
Shock Seal O-Ring x8

**400020**  
Shock Seal O-Ring x4

**400019**  
Shock Spring Adjust Nut O-Ring x4

**108029**  
M2.0x4.6mm FH/ST HEX Screw (1.5mm HexHead) x4

Front 338634(S)  
Rear 338633(L)

Front 330636(S)  
Rear 330635(L)

**103004**  
**330562A**  
**330563A**

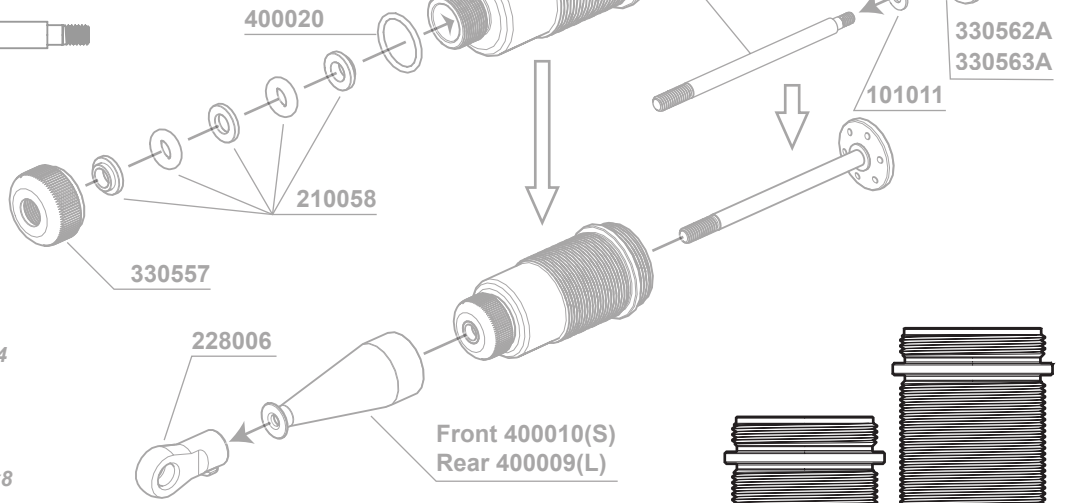

**52**

**Emulsion shock cap system assembly note**

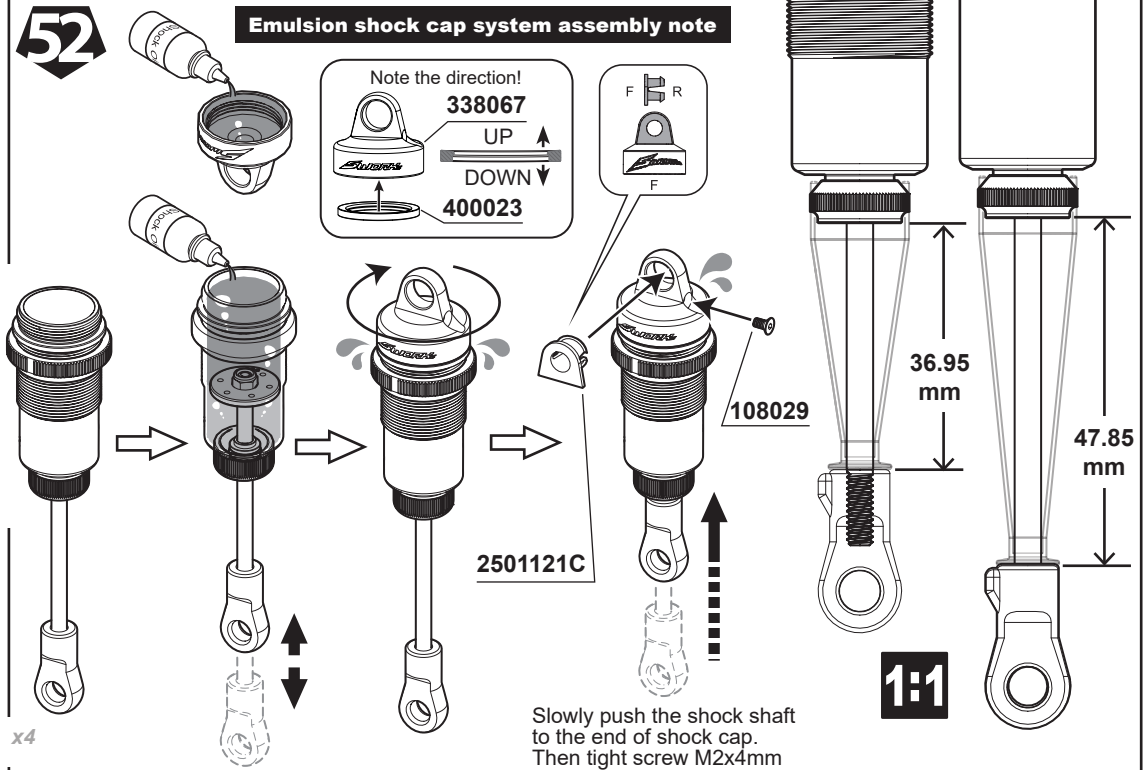
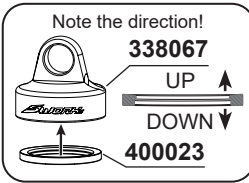

**53**

**115170**  
S350 BBS Option Shock SpringB-1(90X1.4X7.5) x2

**115168**  
S350 BBS Option Shock SpringA-1(75X1.4X6.5) x2

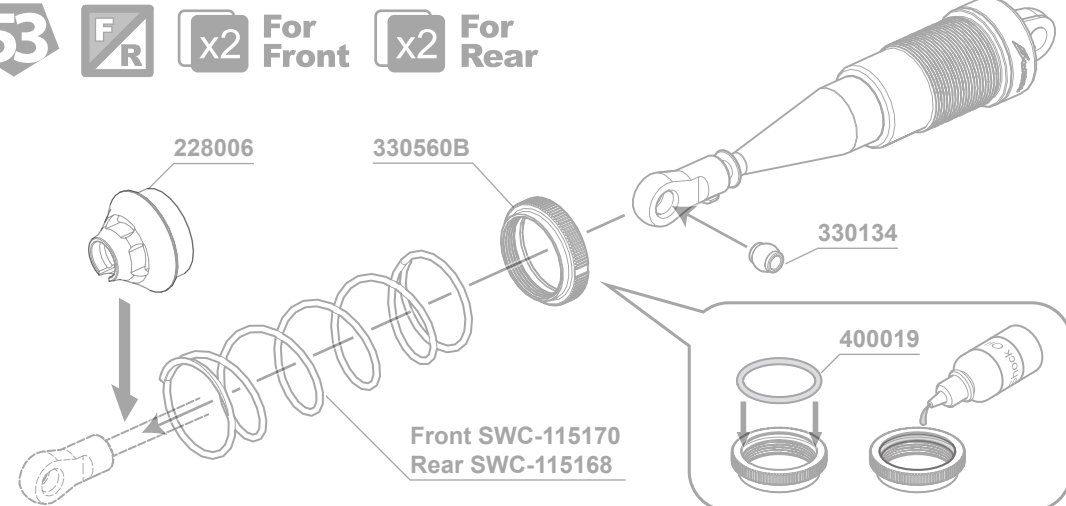



**105006A**  
M3x28mm Cap Screw x2



**105013A**  
M3x25mm Cap Screw x2

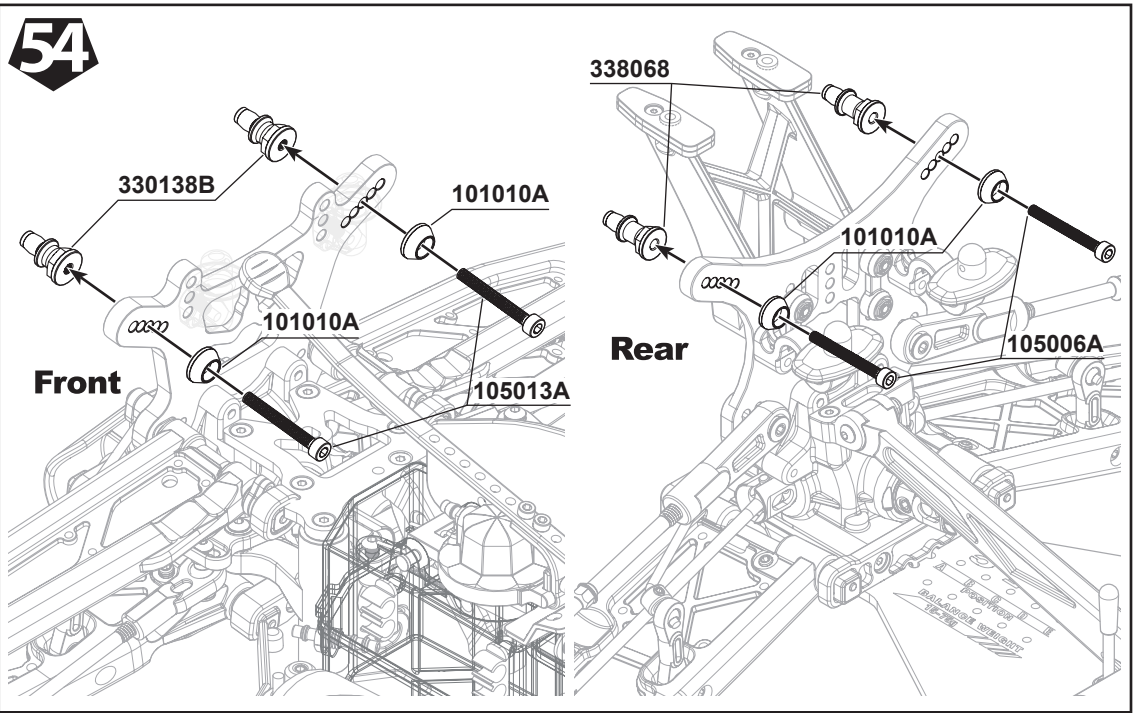

**103003A**  
Flange M3 Nut Lock x4

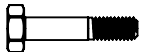

**330243**  
SWORKz 3x16mm Shock Hex Screw Clockwise x2

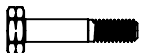

**330243**  
SWORKz 3x16mm Shock Hex Screw Anti-Clockwise x2

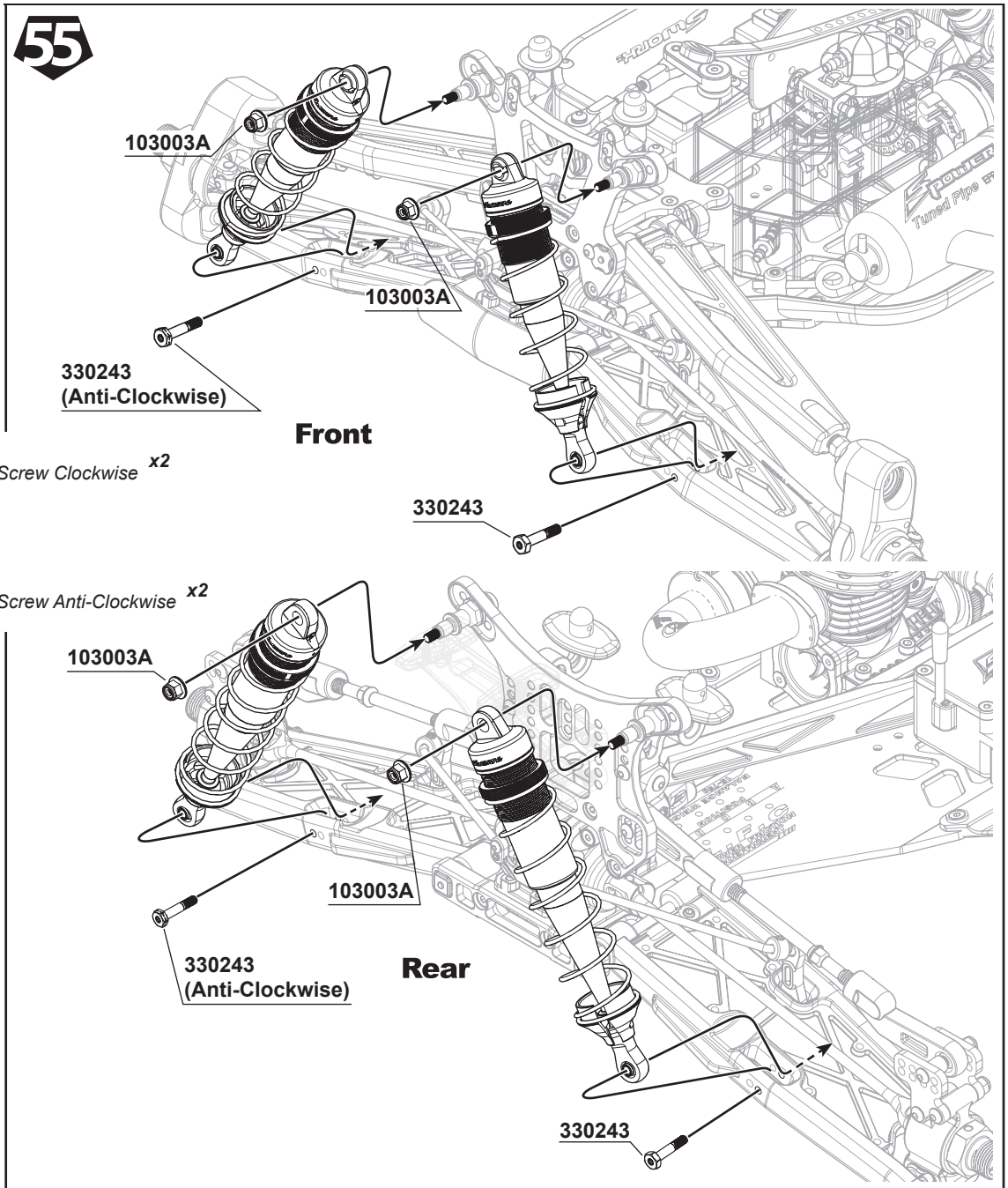



108006  
M3x8mm FH/ST HEX Screw x1

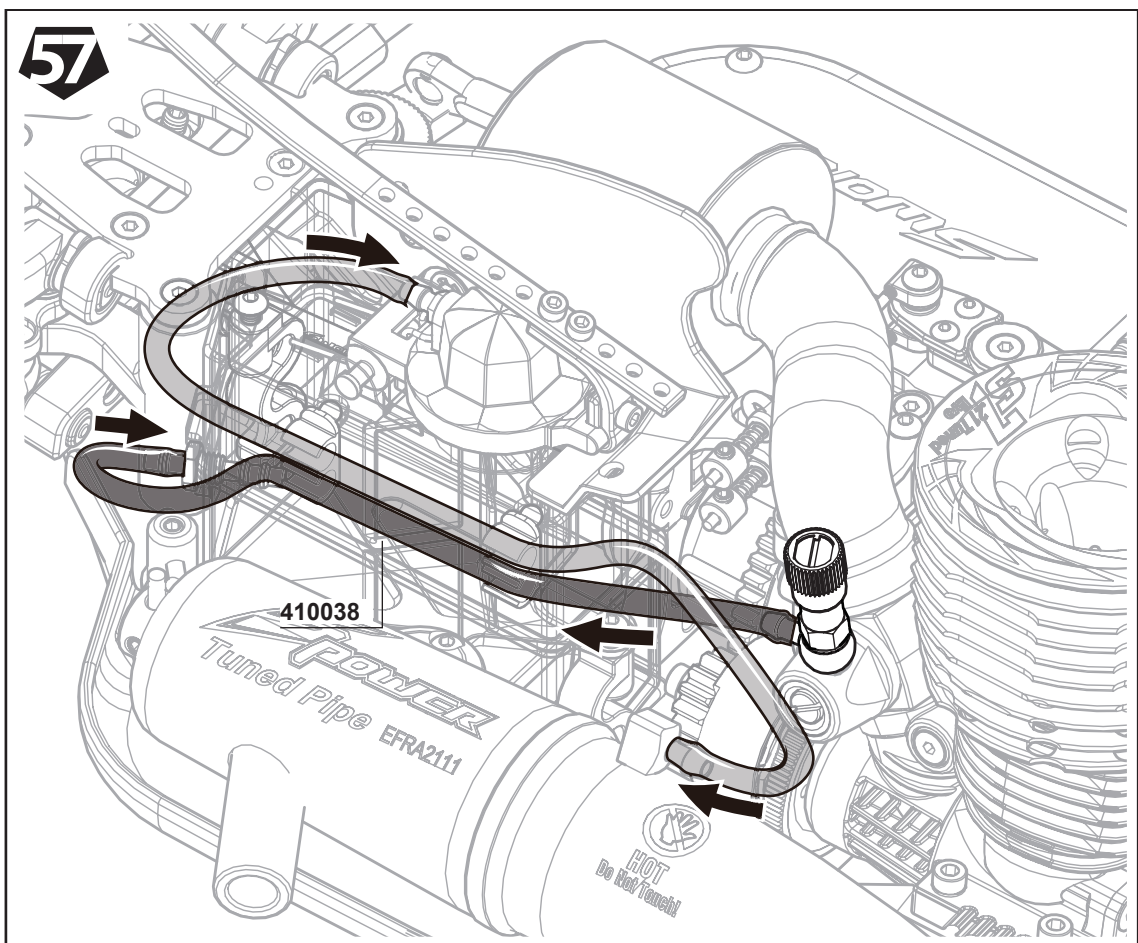
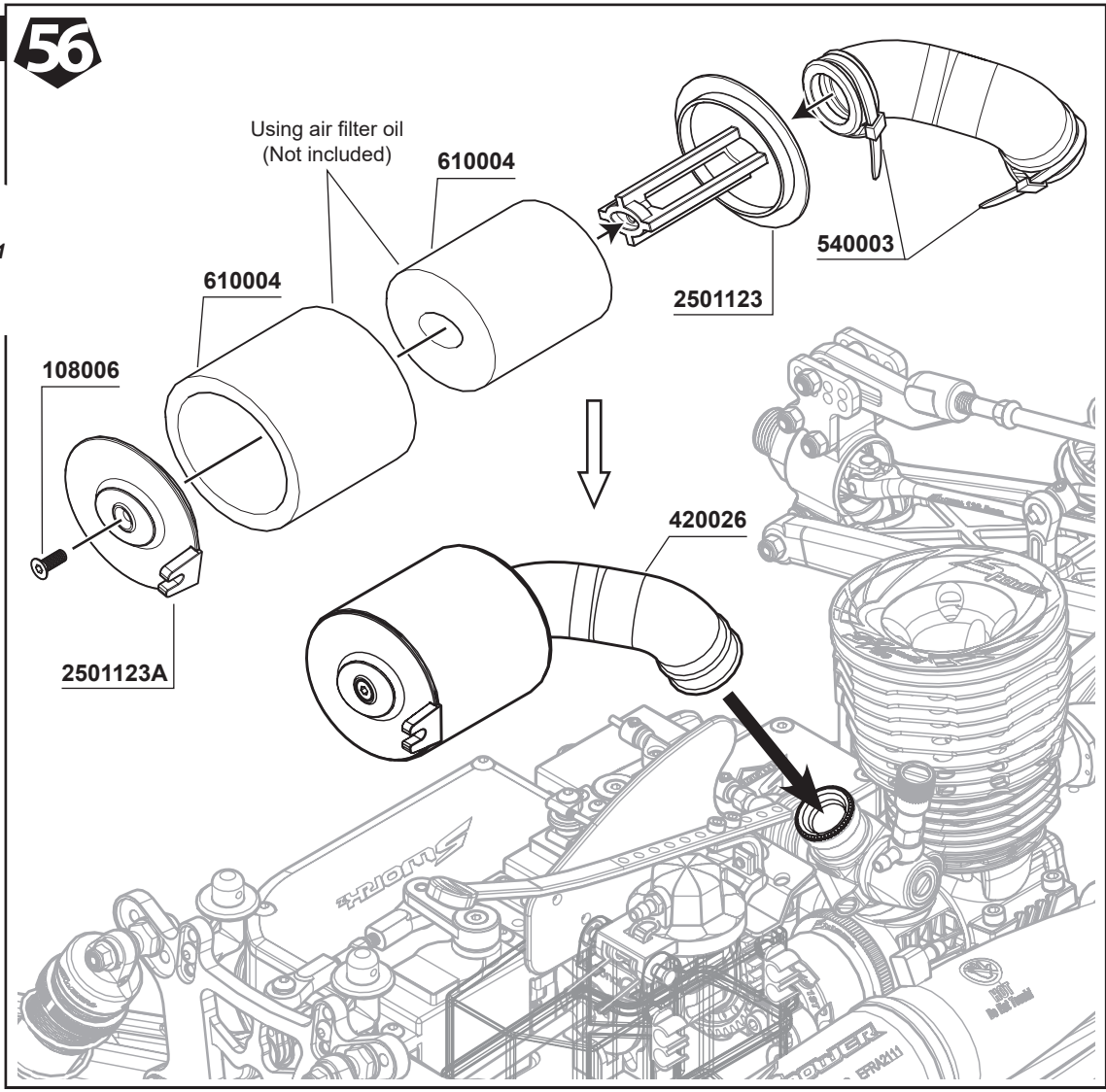

**Attention!**  
The S35-T2 body post positions are different as of the body shell's.  
Please check the "RED DOTs" marked on the body shell. Or follow  
the manual's instructions for the actual body posts positions.

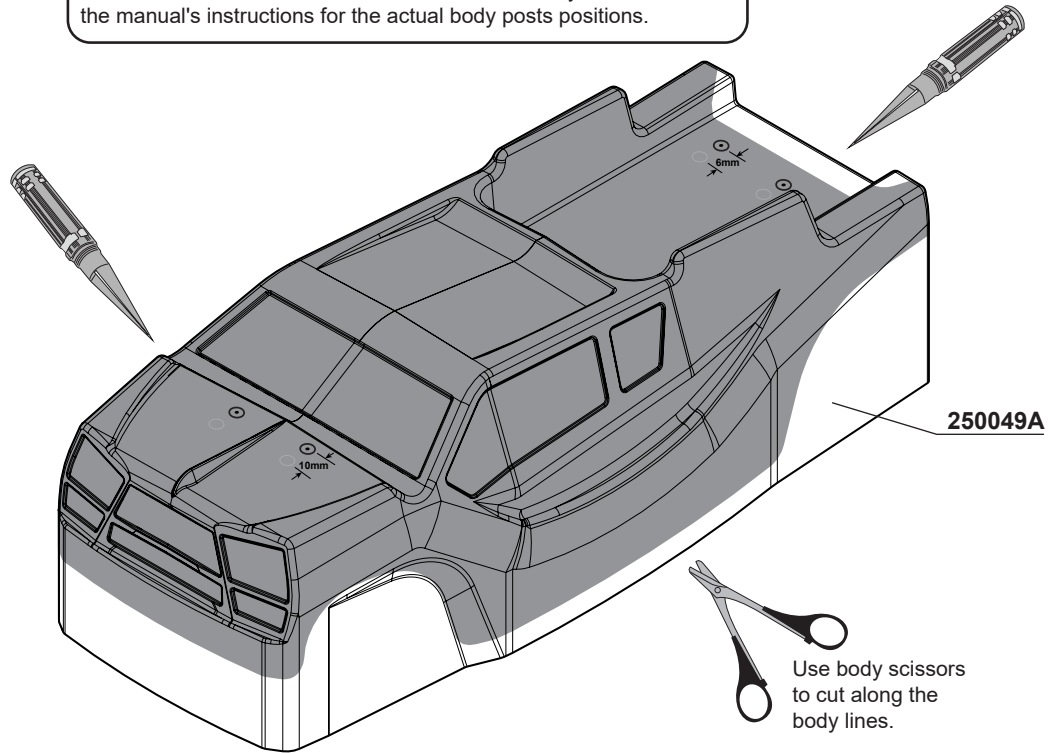

Use water/washing  
solution to clean  
body.

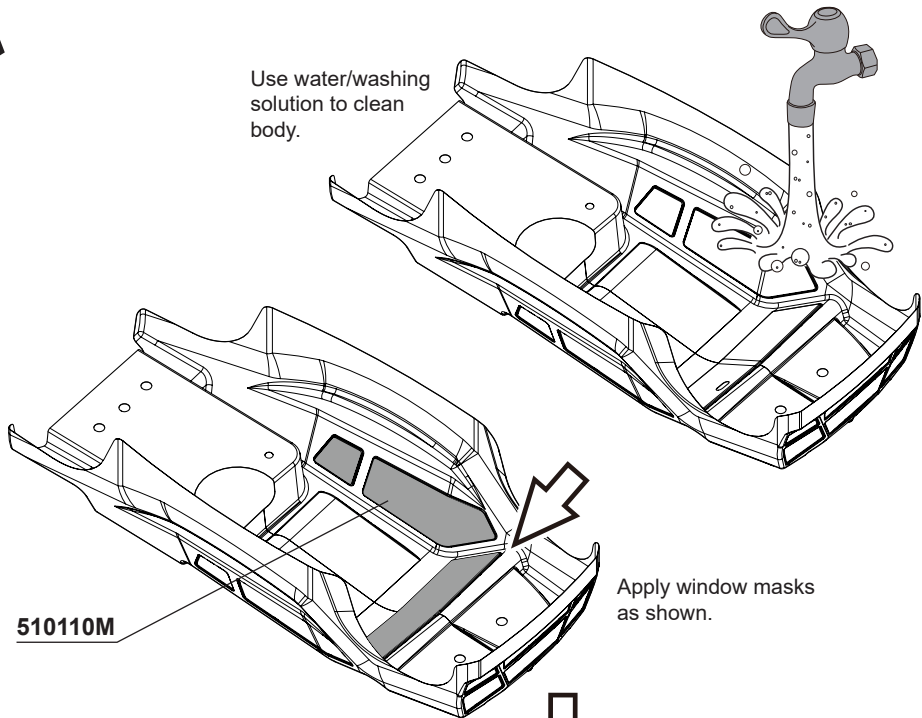

Paint body.

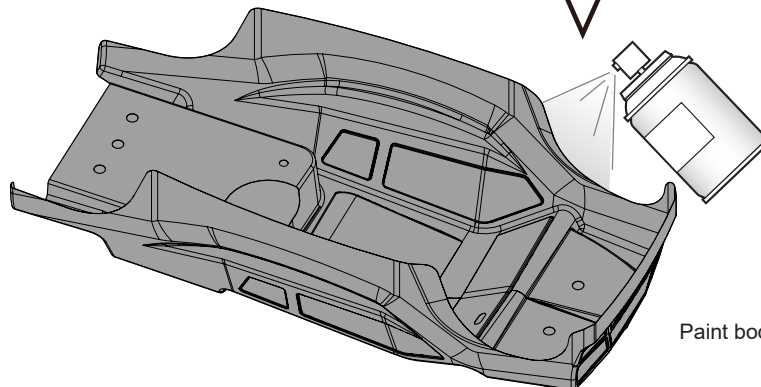

**60**



**105005**  
M3x12mm Cap Screw x2



**106025**  
M2.5x8mm Hex Socket OH/TP Screw x5

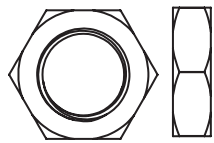
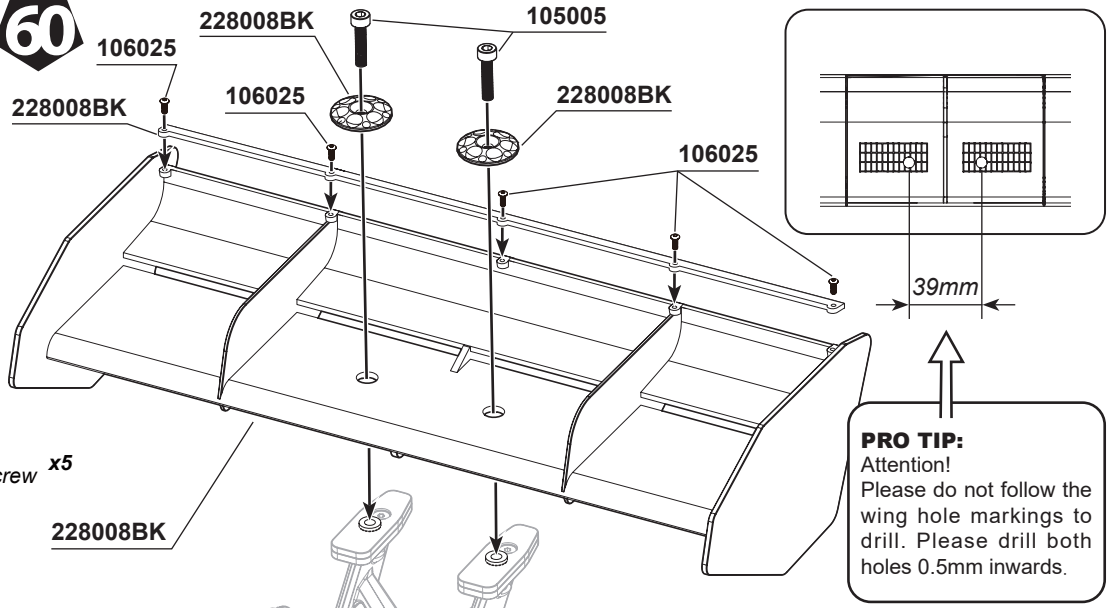

**330122A**  
Wheel Nut x4

**61**

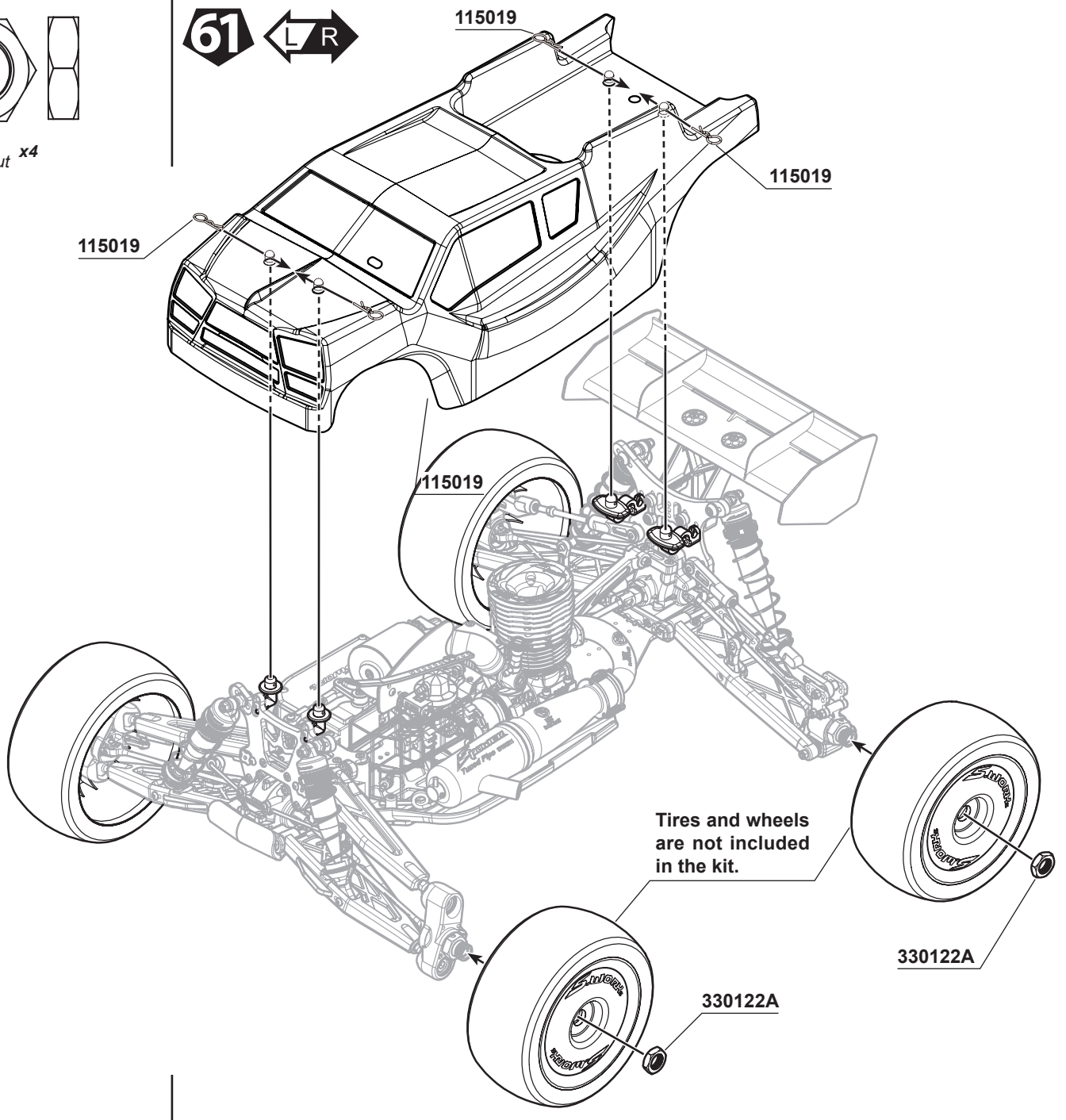

Name: SWORKz  
 Date: \_\_\_\_\_  
 Track: \_\_\_\_\_

**Diff. Oil**  
 Front: 15000  
 Center: 15000  
 Rear: 5000

**Track Conditions**  
 Size:  Open  Med.  Tight  
 Traction:  High  Med.  Low  
 Surface:  Smooth  Med.  Bumpy

**Tire**  
 Front T-Pro Rear T-Pro  
 Type: 3401-T3 Type: 3401-T3  
 Foam: T-Pro Foam: T-Pro

**Engine**  
 Type: Reds 721 Muffler: 2143  
 Gasket: \_\_\_\_\_ mm Fuel: Shoot  
 Plug: TS3

**Clutch**  
 Clutch shoes: 4xAlu  
 Spring: 1.1 mm  
 Clutch bell / Spur gear: 13/48

### Front Suspension

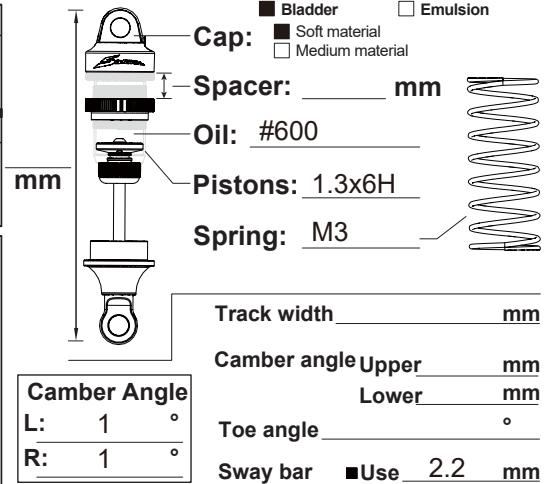
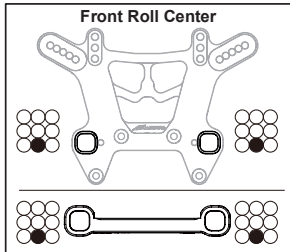
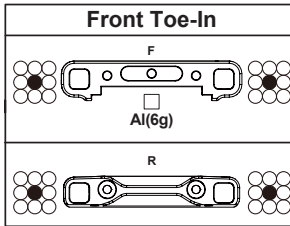
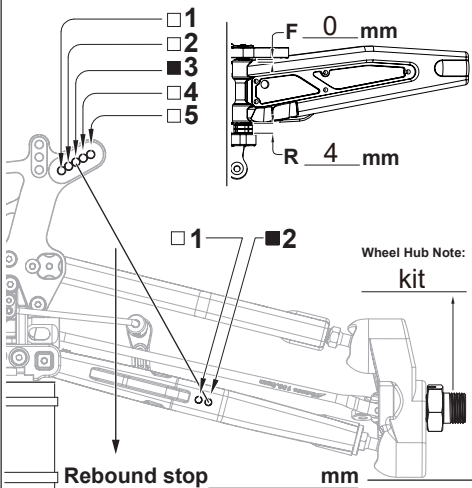

### Rear Suspension

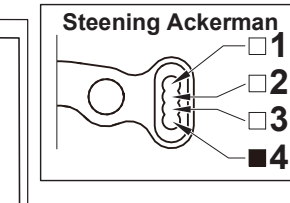
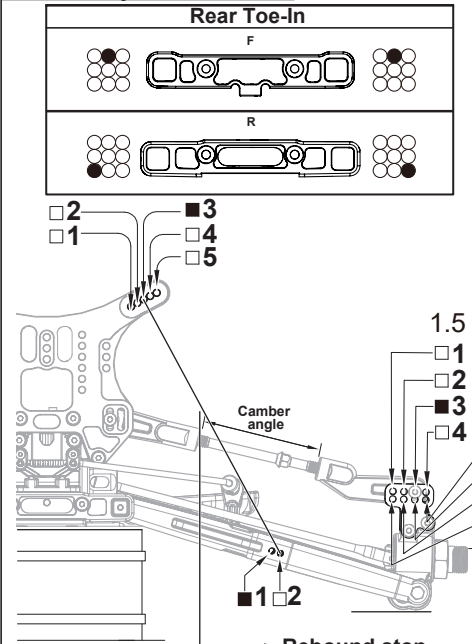

Body: SWORKz RS3  
 Wing: Standard

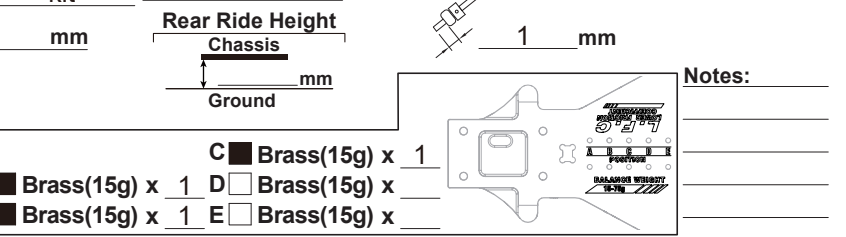
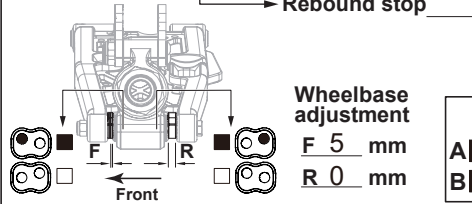
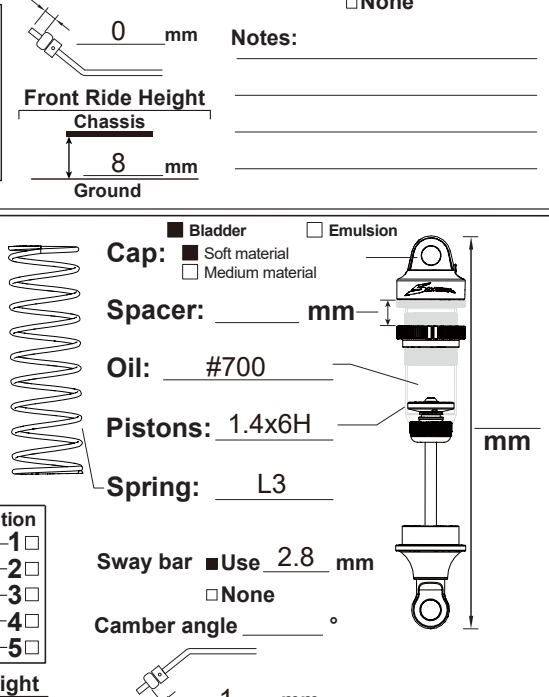
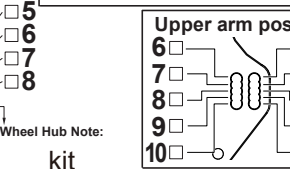
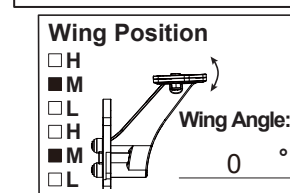

### Option Parts List

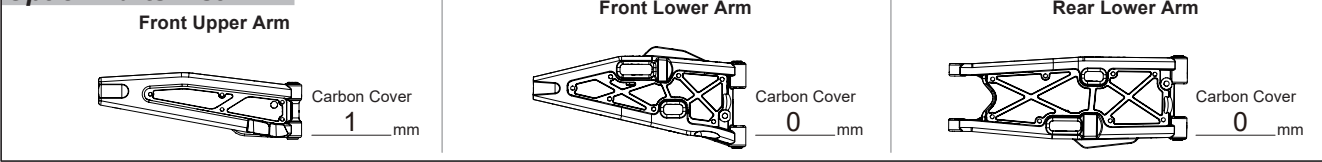

Name: \_\_\_\_\_  
 Date: \_\_\_\_\_  
 Track: \_\_\_\_\_

**Diff. Oil**  
 Front: \_\_\_\_\_  
 Center: \_\_\_\_\_  
 Rear: \_\_\_\_\_

**Track Conditions**  
 Size:  Open  Med.  Tight  
 Traction:  High  Med.  Low  
 Surface:  Smooth  Med.  Bumpy

**Tire**  
 Front Type: \_\_\_\_\_  
 Front Foam: \_\_\_\_\_  
 Rear Type: \_\_\_\_\_  
 Rear Foam: \_\_\_\_\_

**Engine**  
 Type: \_\_\_\_\_ Muffler: \_\_\_\_\_  
 Gasket: \_\_\_\_\_ mm Fuel: \_\_\_\_\_  
 Plug: \_\_\_\_\_

**Clutch**  
 Clutch shoes: \_\_\_\_\_  
 Spring: \_\_\_\_\_ mm  
 Clutch bell / Spur gear: \_\_\_\_\_

### Front Suspension

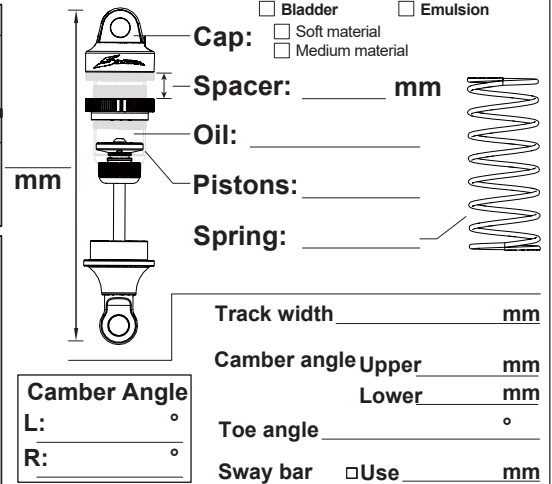
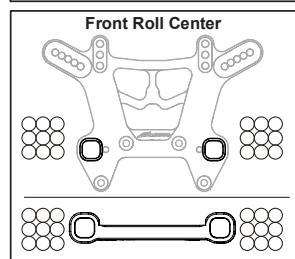
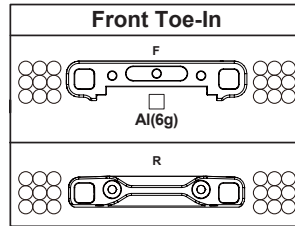
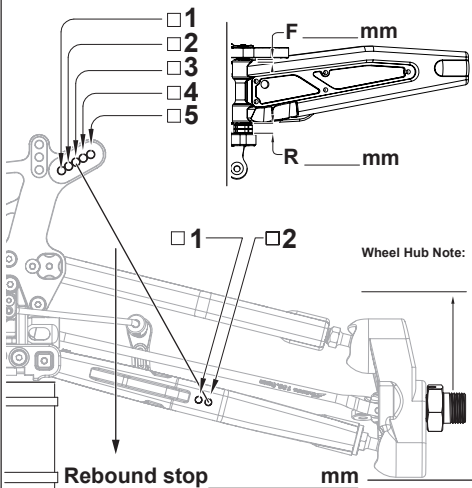

### Rear Suspension

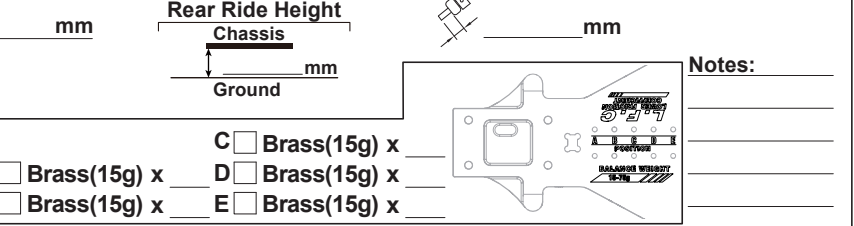
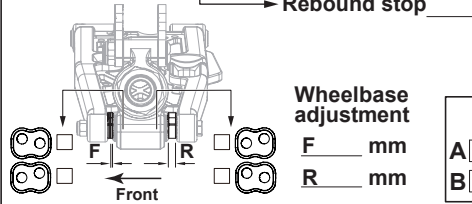
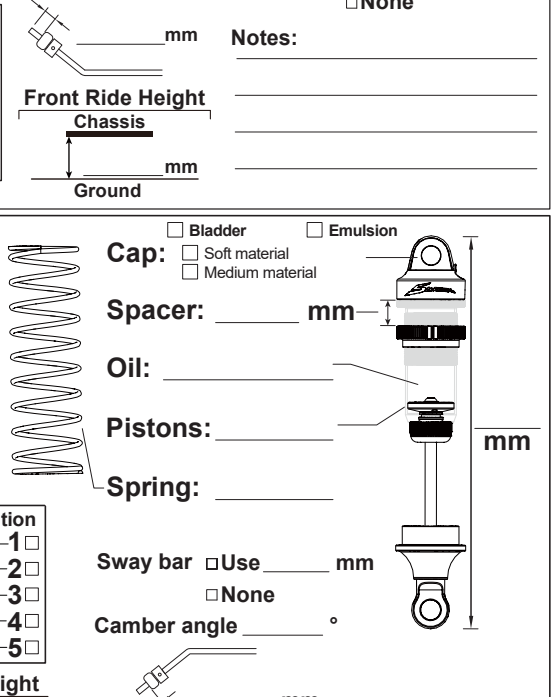
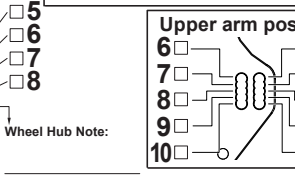
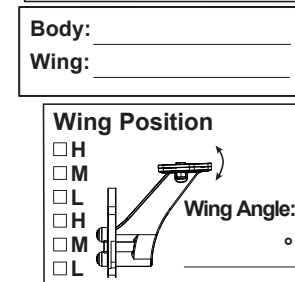
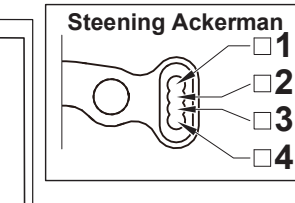
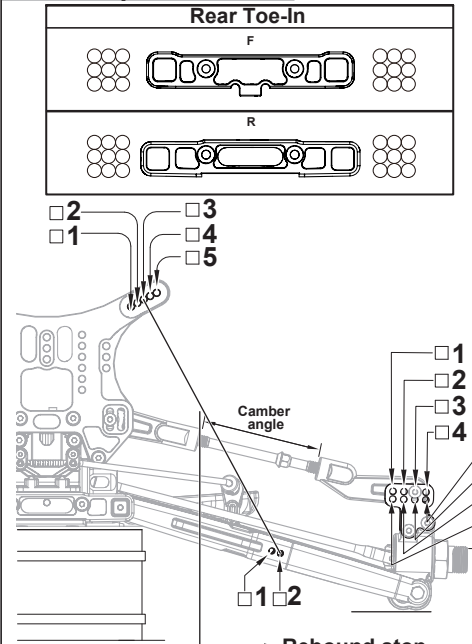

### Option Parts List

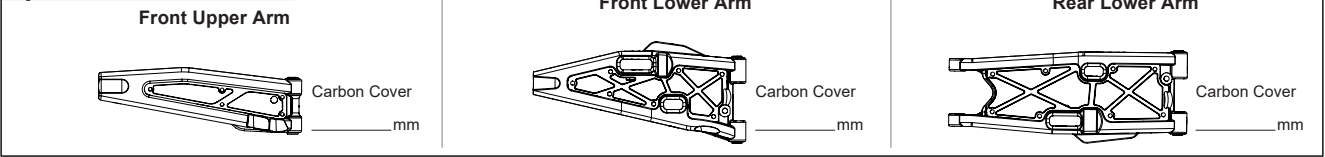

# Parts No. List

Part No.	Part Name	Q'ty in Use	Item No.	Part No.	Part Name	Q'ty in Use	Item No.
210091	S35-3W Plastic Front/Rear Big Bore Diff Case	2	SW-210091	330661A	S35-T/S35 Series Competition Center Drive Join (5mm set screw)	2	SW-330661A
210079A	S35-4 Plastic Center Big Bore HET Diff Case	1	SW-210079A	330767A	S35-3 Series Steel F-Center Dive Shaft (88mm)	1	SW-330767
210048X	S35-T/S35-GT Tubed Floating Fuel Filter System Tank Set (150cc)	1	SW-210048X	330777A	S35-4 Series Steering Linkage Ball Stud 7mm (L7)	4	SW-330777A
2501115	S350 Rear Lower Arm Dusty Cover with Fuel Sprinkle Guard	1	SW-2501115	330782	S35-3 Series Rear Hub Carriers Hinge Pin	2	SW-330782
2501124	S350 Center Diff. Mount Set	2	SW-2501124	330822	S35-T Steel Center Rear Drive Shaft 165mm	1	SW-330822
2501529	S350 BX1/BR1 Rear Chassis Brace	1	SW-2501529	338011	S35 series Pinion Gear Stopper (5x7x5.1mm)	2	SW-338011
2501097B	S35 Series Front Bumper	1	SW-2501097B	338014	S35-3W T-7075AL Rear Lower Fully Adjustable Toe-In Block (3 degree)	1	SW-338014
2501121C	S35/S350 Series Ball End Set with Shock Plastic Parts	2	SW-2501121C	338025	S35-3W Bevel Gear Shaft	6	SW-338025
2501122B	S35/S350 Series Setting Bellcrank Set 2.0 Set (with Servo Horn)	1	SW-2501122B	338027	S35-3W Front/Rear Diff. Outdrive	4	SW-338027
2501126A	S350/S350T Series Option Air Filter Extension Set	1	SW-2501126A	338028	S35-3W Center Diff. Outdrive	2	SW-338028
2502040-01	S350T Rear Plastic Chassis Brace	1	SW-2502040-01	338041	S35-3/4 Series Center HET Spur Gear (48T)	1	SW-338041
2502040-02	S350T Body Mount with Fuel Tank Ring-pull	1	SW-2502040-02	338043	S35-3/4 Series Servo Saver Nut with Screw Fixed	1	SW-338043
2503260-01	S353 Series Plastic Wheel Hub Inserts Set	1	SW-2503260-01	338045	S35-T Series HET System Pinion Gear 10T	2	SW-338045
2503260-02	S35-3 Series Plastic Arm Inserts Set	1	SW-2503260-02	338046	S35-T Series HET System Crown Gear 46T	2	SW-338046
2503260-04	S35-3 Series Plastic Knuckle Inserts Set	1	SW-2503260-04	338048	S35-4 Series Servo Saver Shaft	2	SW-338048
2503261A	S35-3/GT Series Gear Box Set (Fit 5x13x4mm Ball Bearing)	2	SW-2503261A	338049	S35-4 Series T7 Aluminum Rear Front Lower Suspension Plate (RF)	1	SW-338049
2503264	S35-3 Nitro Buggy Radio Tray Set	1	SW-2503264	338051	S35-4 Series T7 Aluminum Steering Knuckle Plate (R=L)	2	SW-338051
2503264A	S35-3 Series Front Steering Knuckle (Type 2.0) L	1	SW-2503264A	338052	S35-4 Series T7 Aluminum Setting Bellcrank Upper Part-A (with 2Hole)	1	SW-338052
2503270-3	S35-3 Series Front Steering Ball Ends	2	SW-2503270-3	338053	S35-4 Series T7 Aluminum Steering Plate	1	SW-338053
228001	S35-4 Series Plastic Inserts Set	2	SW-228001	338056	S35-4 Series Lower Arm Hinge Pin (68.5mm)	4	SW-338056
228002-1	S35-4 Series Plastic Rear Wheel Hub (R=L)	2	SW-228002-1	338057	S35-4 Series T7 Aluminum Front Upper Arm Holder	1	SW-338057
228002-2	S35 Series Plastic Front Chassis Shorty Brace	1	SW-228002-2	338058	S35-4 Series T7 Aluminum Front Lower Arm Plate (FF)	1	SW-338058
228003A	S35 Series Integrated Wing Mount Set 2.0	1	SW-228003A	338059	S35-4 Series T7 Aluminum Front Lower Arm Holder (FR)	1	SW-338059
228004	S35-4 Series Plastic Side Guard Set	1	SW-228004	338067	S35-4 Series Emulsion/Bladder 2 Ways Syatem Shock Cap 4	1	SW-338067
228006	S35 Series Shock End/Body Mount/Ball Ends Set	2	SW-228006	338068	S35-4 Series T7 Aluminum Shock Stud (L)	2	SW-338068
228008BK	SWORKz 1/8 Off Road Formula 2.0 Race Wing (BK)	1	SW-228008BK	338070	S35 Series Rear Upper Sus. Arm Ball Stud	2	SW-338070
228010-F	S35-T2 Series Front Lower Arm	2	SW-228010-F	338085	S35-T2/E T7075 Aluminum Front Shock Tower	1	SW-338085
228010-R	S35-T2 Series Rear Lower Arm	2	SW-228010-R	338086	S35-T2/E T7075 Aluminum Rear Shock Tower	1	SW-338086
228011	S35-T2 Series Front Upper Arm	2	SW-228011	338087	S35-T2 Nitro T7075 Aluminum Lightened Main Chassis	1	SW-338087
210058	S350 New BBS System Shock Seal Washer 3.6X7X2.5mm	8	SW-210058	340016	S35-4 Series Pro-composite Carbon Rear Wheel Hub Adjust Plate (R=L)	4	SW-340016
210058	S350 New BBS System Shock Seal Washer 3.5X7X1.0mm	4	SW-210058	340017	S35-4 Series Pro-composite Carbon Steering Bellcrank Plate	1	SW-340017
210046	S350 Series LDS Universal Cross Drive Shaft Set 92.5mm (1pc)	4	SW-210046	340028-10	S35-T2 Pro-composite Carbon Front Upper Arm Cover (1.0mm)(2pc)	2	SW-340028-10
210043	S350 Professional Matel Brake Calipers 2.0 A Side	2	SW-210043	400002	O-ring S5 4.8X1.5	6	SW-400002
210043	S350 Professional Matel Brake Calipers 2.0 B Side	2	SW-210043	400005	Shock Spring Adjust Nut O-Ring	4	SW-400005
210018	Brake Spring	2	SW-210018	400006	Shock Seal O-Ring	8	SW-210058
210018	Throttle Rod 50mm	1	SW-210018	400009	Shock Boot (L)	2	SW-400009
210018	Throttle Rod Spring	1	SW-210018	400010	Shock Boot (S)	2	SW-400010
210018	Brake Rod 60mm	2	SW-210018	400019	S350 New BBS System Shock Spring Adjust Nut O-Ring	4	SW-400019
200193	Antenna Tube	1	SW-200193	400020	S350 New BBS System Shock Seal O-Ring 4	4	SW-400020
250049A	S35-T/ZEUS Speed Rhino III Body Shell (1.5mm)	1	SW-250049A	400022A-S	S35 Series BBS System Pro Shock Bladder (Soft)	4	SW-40022A-S
320010	S35-3W Diff. Bevel Gear 10T	12	SW-328001	400023	S35 Series BBS System Seal O-Ring for Emulsion Shock Cap 4	4	SW-400023
320009	S35-3W Diff. Bevel Gear 20T	6	SW-328001	410038	Super Silicone Tube 2455x30mm (Transparent)	1	SW-410038
330006	Tornado Clutch Shoes	3	SW-330006	420010	Antenna Cup	1	SW-420010
330008A	SWORKz Tornado Fly Wheel Set (GM)	1	SW-330008A	420011	Fuel Tube	2	SW-420011
330008A	Tornado Fly Wheel Center Nut	1	SW-330008A	420026	S350/S350T Series Option Air Filter Extension Adapter	1	SW-420026
330008A	Fly Wheel Collect	1	SW-330008A	510080A	SWORKz 1/8 Off Road Formula Race Wing Decal	1	SW-228008BK
330015	Pin M2.2x9.9mm	6	SW-330015	510091	SWORKz Original Logo Sticker	1	SW-510091
330090	S350 Series Carbon Fiber Center Diff. Plate	1	SW-330090	540003	CABLE STRAPS FOR AIRFILTER	2	SW-540003
330100A	S350 Engine Mount (L) (HC)	1	SW-330100A	610004	Air Filter Outer Foam	1	SW-610004
330100A	S350 Engine Mount (R) (HC)	1	SW-330100A	610004	Air Filter Foam	1	SW-610004
330104	Brake Cam (S)	1	SW-330104	610019	S35-3 Series Servo Saver Spring Dusty Protect Sponge	1	SW-610019
330104	Brake Cam (L)	1	SW-330104	610020	S35-3 Series Center Big Bore Plastic Diff. Case Gasket	1	SW-610020
330104	Brake Cam	1	SW-330104	610023	S35-3W Diff. Gasket (0.4T)	2	SW-610023
330114A	S350 Sseries Servo Saver Post (HC)	1	SW-330114A	115003A	SWORKz Tornado Clutch Spring II (1.0mm)	3	SW-115003A
330117A	S350 Series Knuckle Pivot Ball Washer(GM)	2	SW-330117A	115004A	Servo Saver Spring	1	SW-115004A
330118A	S350 Series Knuckle Pivot Ball Nut(GM)	4	SW-330118A	115005	Rear Sway Bar 2.8mm	1	SW-115005
330119	Front Upper Arm HingPin	2	SW-330119	115006	Rear Sway Bar 2.6mm	1	SW-115006
330121A	S350 Wheel Hub(HC)	4	SW-330121A	115008A	Front Sway Bar 2.3mm	1	SW-115008A
330122A	S350 Wheel Nut (HC)	4	SW-330122A	115011A	S35-GT Series Pipe Spring (L)	1	SW-115011A
330124	Pin M3.0x16.8mm	4	SW-330124	115019	Body Clip	2	SW-115019
330125	Rear Upper Sus. Arm Ball Stud	4	SW-330125	115035A	Front Sway Bar 2.2mm	1	SW-115035A
338089	S35-T2/E Steering Linkage Turnbuckle M4x80mm	2	SW-338089	115098	Brake Pad Spring	4	SW-115098
330134	Shock Ball Stud	12	SW-330134	115168	S35 Series Black Competition Rear Shock Spring (L2-Dot)(86X1.6X10.75)	2	SWC-115168
330136	Sway Bar Ball Stud	4	SW-330136	115170	S35 Series Black Competition Front Shock Spring (S3-Dot)(70X1.6X8.5)	2	SW-115170
330137	Clutch Bell 13T	1	SW-330137	116004R	Ball Bearing 6x10x3mm (Red Rubber Case)	4	SW-116004R
330138B	S350 EVO Aluminum Shock Cap Stud (-1.3mm)	2	SW-330138B	116006R	Ball Bearing 8x16x5mm (Red Rubber Case)	14	SW-116006R
330140A	Pipe Holder(GM)	1	SW-330140A	116009	Ball Bearing M5x8x2.5 ZZ (4PC)	2	SW-116009
330140A	Pipe Spring	1	SW-330140A	116010R	Ball Bearing 5x10x4mm (Red Rubber Case)	2	SW-116010R
330155	Steering Servo Turnbuckle (M3x30mm)	2	SW-330155	116019R	Ball Bearing 5x13x4mm (Red Rubber Case)	4	SW-116019R
330156A	Adjuster Knob(GM)	4	SW-330156A	117003	Flange Ball Bearing 3x6x2.5mm	4	SW-117003
330157A	Brake Adjuster Knob(GM)	2	SW-330157A	118001-24	S35-T2/T2e Front Sway Bar 2.4mm	1	SW-118001-24
330243	SWORKz 3x16mm Shock Hex Screw Clockwise	2	SW-330243	118001-26	S35-T2/T2e Front Sway Bar 2.6mm	1	SW-118001-26
330243	SWORKz 3x16mm Shock Hex Screw Anti-Clockwise	2	SW-330243	118002-26	S35-T2/T2e Rear Sway Bar 2.6mm	1	SW-118002-26
330252	S350 BX1/BR1 Steering Knuckle Pivot Ball Turnbuckle 4	4	SW-330252	118002-28	S35-T2/T2e Rear Sway Bar 2.8mm	1	SW-118002-28
330399B	S35-3 Series Aluminum Rear Chassis Brace Mount (GM)	1	SW-330399B	101004	Washer 3.5X10X0.2mm	12	SW-101004
330458	S350T Rear Upper Arm Turnbuckle M5x72mm	2	SW-330458	101010A	M3 Countersunk Washer(GM)	4	SW-101010A
330557	S350 New BBS System Shock Seal Cap (GM)	4	SW-330557	101011	M2.6x6xT0.6mm	4	SW-101011
330560B	S35 New BBS System Shock Spring Adjust Nut (BK)	4	SW-330560B	101013	3mm Spring Washer	4	SW-101013
330562A	S350 New BBS System Shock Piston 1.3mmX6 Holes (BK)	2	SW-330562A	101015	M5x8xT0.4mm	4	SW-101015
330563A	S350 New BBS System Shock Piston 1.4mmX6 Holes (BK)	2	SW-330563A	101016	M5x8xT0.8mm	1	SW-101016
330580	S350 Competition Series Professional Brake Disc	2	SWC-330580	101018	SHIM 13x16x0.2mm	12	SW-101018
330633	S350 BBS System +5.6mm Shock Body L (HD)	2	SW-330633	101019	SHIM 6.0x10.0x0.2mm	1	SW-101019
330634	S350 BBS System +5mm Shock Body S (HD)	2	SW-330634	101020A	S350 Sries 3mm Countersunk Washers (GM)	2	SW-101020A
330635	S350 New BBS System +5.5mm Shock Shaft (L)	2	SW-330635	101021	M3x8xT0.8mm	3	SW-101021
330636	S350 New BBS System +1.3mm Shock Shaft (S)	2	SW-330636	101039	Steel Washer 5x12x0.3mm	6	SW-101039
330647	S350 BBD Special Brake Cam	1	SWC-330647	103001	M3 Nut Lock	25	SW-103001



## Spare Part List

Part No.	Part Name	Q'ty in Use	Item No.	Item No.	Part Name
103003A	Flange M3 Nut Lock (GM)	5	SW-103003A	SW-228001	S35-4 Series Plastic Inserts Set (2Set)
103004	M2.5mm Nut Lock	4	SW-103004	SW-228002-1	S35-4 Series Plastic Rear Wheel Hub (R=L)(2PC)
103005	M4mm Nut Lock (BK)	1	SW-103005	SW-228002-2	S35 Series Plastic Front Chassis Shorty Brace (1PC)
104004	M3x3mm Set Screw	13	SW-104004	SW-228003A	S35 Series Integrated Wing Mount Set 2.0
104005	M3x4mm Set Screw	4	SW-104005	SW-228004	S35-4 Series Plastic Side Guard Set
104010	M5x4mm Set Screw (Flat Bottom)	6	SW-104010	SW-228006	S35 Series Shock End/Body Mount/Ball Ends Set (2Set)
104011	M4x4mm Set Screw (Flat Bottom)	1	SW-104011	SW-228008BK	SWORKz 1/8 Off Road Formula 2.0 Race Wing (BK)
105001	M3x8mm Cap Screw	1	SW-105001	SW-228010-F	S35-T2 Series Front Lower Arm (1PC)
105005	M3x12mm Cap Screw	6	SW-105005	SW-228010-R	S35-T2 Series Rear Lower Arm (1PC)
105018	M2x6mm Cap Head Screw	1	SW-105018	SW-228011	S35-T2 Series Front Upper Arm (1PC)
105013A	M3x25mm Cap Screw	4	SW-105013A	SW-2501097B	S35 Series Front Bumper (2PC)
105007A	M4x8mm I-Head Screw Thin	4	SW-105007A	SW-2501115	S350 Rear Lower Arm Dusty Cover with Fuel Sprinkle Guard
105006A	M3x28mm Cap Screw full thread	2	SW-105006A	SW-2501121C	S35/S350 Series Ball End Set with Shock Plastic Parts
106001	M3x8mm Hex Soket OH/TP Screw	3	SW-106001	SW-2501122B	S35/S350 Series Setting Bellcrank Set 2.0 Set (with Servo Horn)
106002	M3x10mm Hex Soket OH/TP Screw	18	SW-106002	SW-2501124	S350 Center Diff. Mount Set (2 Set)
106003	M3x16mm Hex Soket OH/TP Screw	8	SW-106003	SW-2501126A	S350/S350T Series Option Air Filter Extension Set
106006	M3x20mm Hex Soket OH/TP Screw	1	SW-106006	SW-2501529	S350 BX1/BR1 Rear Chassis Brace
106007	M3x12mm Hex Soket OH/TP Screw (HT)	9	SW-106007	SW-2502040-01	S350T Rear Chassis Brace
106008	M3x12mm Hex Soket OH/TP Screw	4	SW-106008	SW-2502040-02	S350T Body Mount with Fuel Tank Ring-pull
106009	M3x25mm Hex Soket OH/TP Screw	10	SW-106009	SW-2503260-01	S353 Series Plastic Wheel Hub Inserts Set
106013	M2.5x8mm 1.5mmHex Soket OH/ST Screw	6	SW-106013	SW-2503260-02	S35-3 Series Plastic Arm Inserts Set
106015	M3x5mm Hex Soket OH/TP Screw	2	SW-106015	SW-2503260-04	S35-3 Series Plastic Knuckle Inserts Set
106020	M2.5x5mm 1.5mmHex Soket OH/ST Screw	16	SW-106020	SW-2503261A	S35-3/GT Series Gear Box Set (Fit 5x13x4mm Ball Bearing)
106025	M2.5x8mm Hex Soket OH/TP Screw	5	SW-106025	SW-2503262	S35-3 Nitro Buggy Radio Tray Set
106021A	S35 Series M4x10mm Hex Soket OH/TP Set Screw	4	SW-106021A	SW-2503264A	S35-3 Series Front Steering Knuckle (Type 2.0)
108001	M3x12mm FH/ST HEX Screw	20	SW-108001	SW-2503270-03	S35-3 Series Front Steering Ball Ends (4PC)
108003	M3x10mm FH/ST HEX Screw	21	SW-108003	SW-200193	Antenna Tube
108005	M3x14mm FH/ST HEX Screw	2	SW-108005	SW-210018	Throttl Linkage Set
108006	M3x8mm FH/ST HEX Screw	21	SW-108006	SW-210043	S350 Professional Matel Brake Calipers 2.0 Set
108007	M3x6mm FH/ST HEX Screw	10	SW-108007	SW-210048X	S35-GT2/S35-T2 Series Tubed Floating Fuel Filter System Tank Set
108008	M3x35mm FH/ST HEX Screw	4	SW-108008	SW-210058	S350 series BBS Shock Seal Kit
108010	M4x10mm FH/ST HEX Screw	6	SW-108010	SW-210079A	S35-4 Plastic Center Big Bore HET Diff Case
108011	M4x12mm FH/ST HEX Screw	1	SW-108011	SW-210091	S35-3W Plastic Front/Rear Big Bore Diff Case
108012	M4x16mm FH/ST HEX Screw	8	SW-108012	SW-218018	S35-T2/e Series Universal Cross Drive Shaft Set 136.5mm (1PC)
108013	M4x8mm FH/ST HEX Screw	1	SW-108013	SW-250049A	S35-T/ZEUS Speed Rhino III Body Shell (1.5mm)
108019	M2.6x6mm FH/ST HEX Screw	2	SW-108019	SW-328001	S35-3/4 Series HET Diff. Bevel Gear Set
108029	M2.0x4.6mm FH/ST HEX Screw (1.5mm HexHead)	4	SW-108029	SW-330006	Tornado Clutch Shoes
				SW-330008A	SWORKz Tornado Fly Wheel Set (GM)
				SW-330015	Pin M2.2x9.9mm
				SW-330090	S350 Series Carbon Fiber Center Diff. Plate
				SW-330100A	S350 Sseries Engine Mount Set (HC)
				SW-330104	Brake Cam Set
				SW-330114A	S350 Sseries Servo Saver Post (HC)
				SW-330117A	S350 Series Knuckle Pivot Ball Washer(GM)
				SW-330118A	S350 Series Knuckle Pivot Ball Nut(GM)
				SW-330119	Front Upper Arm HingPin
				SW-330121A	S350 Wheel Hub (HC)
				SW-330122A	S350 Wheel Nut (HC)
				SW-330124	Pin M3.0x16.8mm
				SW-330126A	S350 EVO Steering Turnbuckle M4x40mm
				SW-330134	Shock Ball Stud 6mmxL6.7
				SW-330136	Sway Bar Ball Stud
				SW-330137	Clutch Bell 13T
				SW-330138B	S350 Series Aluminum Shock Cap Stud (-1.3mm)(2PC)
				SW-330140A	S350 SeriesPipe Holder(GM)
				SW-330155	Steering Servo Turnbuckle (M3x30mm)
				SW-330156A	S350 Series Adjuster Knob (Included Brake Adjuster Knob)(GM)
				SW-330157A	Brake Adjuster Knob(GM)
				SW-330243	SWORKz 3x18mm Shock Hex Screw Set (Anti-Clockwise)
				SW-330252	S350 BX1/BR1 Steering Knuckle Pivot Ball Turnbuckle
				SW-330399B	S35-3 Series Aluminum Rear Chassis Brace Mount (GM)
				SW-330458	S350T Rear Upper Arm Turnbuckle M5x72mm
				SW-330557	S350 New BBS System Shock Seal Cap (GM)
				SW-330560B	S35 New BBS System Shock Spring Adjust Nut (BK)
				SW-330562A	S35 Series BBS System Shock Piston 1.3mmX6 Holes (BK)(2PC)
				SW-330563A	S35 Series BBS System Shock Piston 1.4mmX6 Holes (BK)(2PC)
				SW-330633	S350 BBS System +5.6mm Shock Body L
				SW-330634	S350 BBS System +5mm Shock Body S
				SW-330635	S350 New BBS System +5.5mm Shock Shaft ( L)
				SW-330636	S350 New BBS System +1.3mm Shock Shaft ( S)
				SW-330661A	S35-T/S35 Series Competition Center Drive Join (5mm Set screw)
				SW-330663A	S35-3 Series Steel R-Center Drive Shaft (115mm)
				SW-330767A	S35-3 Series Steel F-Center Dive Shaft (88mm)
				SW-330777A	S35-4 Series Steering Linkage Ball Stud 7mm(L7)(4PC)
				SW-330782	S35-3 Series Rear Hub Carriers Hinge Pin
				SW-330822	S35-T Steel Center Rear Drive Shaft 165mm
				SW-338011	S35-3 series Pinion Gear Stopper (5x7x5.1mm)(4PC)
				SW-338014	S35-3WT-7075AL Rear Lower Fully Adjustable Toe-In Block(3 degree)
				SW-338045	S35-T Series HET System Pinion Gear 10T
				SW-338046	S35-T Series HET System Crown Gear 46T
				SW-338025	S35-4 HET Bevel Gear Shaft (2PC)
				SW-338027	S35-4 Front/Rear HET Diff. Outdrive (2PC)
				SW-338028	S35-4 Center HET Diff. Outdrive (2PC)
				SW-338041	S35-3/4 Series Center HET Spur Gear (48T)
				SW-338043	S35-3/4 Series Servo Saver Nut with Screw Fixed
				SW-338048	S35-4 Series Servo Saver Shaft(2PC)

## Spare Part List

Item No.	Part Name	Item No.	Part Name
SW-338049	S35-4 Series T7 Aluminum Rear Front Lower Suspension Plate (RF)	SW-115011A	S35-GT Series Pipe Spring (+10mm Longer)
SW-338051	S35-4 Series T7 Aluminum Steering Knuckle Plate (R=L)	SW-115019	Body Clip
SW-338052	S35-4 Series T7 Aluminum Steering Bellcrank Upper Part-A (with 2Hole)	SW-115098	Brake Pad Spring
SW-338053	S35-4 Series T7 Aluminum Steering Plate	SWC-115168	S35 Series Black Competition Rear Shock Spring (L2-Dot)(86X1.6X10.75)
SW-338056	S35-4 Series Lower Arm Hinge Pin (68.5mm)(2PC)	SWC-115170	S35 Series Black Competition Front Shock Spring (S3-Dot)(70X1.6X8.5)
SW-338057	S35-4 Series T7 Aluminum Front Upper Arm Holder	SW-116004R	Ball Bearing 6x10x3mm (Red Rubber Case)(4PC)
SW-338058	S35-4 Series T7 Aluminum Front Lower Arm Plate (FF)	SW-116006R	Ball Bearing 8x16x5mm (Red Rubber Case)(10PC)
SW-338059	S35-4 Series T7 Aluminum Front Lower Arm Holder (FR)	SW-116009	Ball Bearing M5x8x2.5 ZZ (4PC)
SW-338067	S35-4 Series Emulsion/Bladder 2 Ways Syatem Shock Cap (2PC)	SW-116010R	Ball Bearing 5x10x4mm (Red Rubber Case)(4PC)
SW-338068	S35-4 Series T7 Aluminum Shock Stud (L)(2PC)	SW-116019R	Ball Bearing 5x13x4mm (Red Rubber Case)(4PC)
SW-338070	S35 Series Rear Upper Sus. Arm Ball Stud (2PC)	SW-117003	Flange Ball Bearing 3x6x2.5mm (2PC)
SW-338085	S35-T2/E T7075 Aluminum Front Shock Tower	SW-118001-24	S35-T2/T2e Front Sway Bar 2.4mm
SW-338086	S35-T2/E T7075 Aluminum Rear Shock Tower	SW-118001-26	S35-T2/T2e Front Sway Bar 2.6mm
SW-338087	S35-T2 Nitro T7075 Aluminum Lightened Main Chassis	SW-118002-26	S35-T2/T2e Rear Sway Bar 2.6mm
SW-338089	S35-T2/e Steering Linkage Turnbuckle M4x80mm	SW-118002-28	S35-T2/T2e Rear Sway Bar 2.8mm
SW-340016	S35-4 Series Pro-composite Carbon Rear Wheel Hub Adjust Plate (R=L)(2PC)		
SW-340017	S35-4 Series Pro-composite Carbon Steering Bellcrank Plate		
SW-340028-10	S35-T2/e Pro-composite Carbon Front Upper Arm Cover (1.0mm)(2PC)		
SWC-330580	S350 Competition Series Professional Brake Disc		
SWC-330647	S350 BBD Special Brake Cam		
SW-400002	O-ring S5 4.8X1.5		
SW-400005	Shock Spring Adjust Nut O-Ring		
SW-400009	Shock Boot (L)		
SW-400010	Shock Boot (S)		
SW-400019	S350 New BBS System Shock Spring Adjust Nut O-Ring (4PC)		
SW-400020	S350 New BBS System Shock Seal O-Ring (4PC)		
SW-400023	S35-4 Series BBS System Seal O-Ring for Emulsion Shock Cap (4PC)		
SW-400022A-S	S35 Series BBS System Pro Shock Bladder (Soft)(8PC)		
SW-410038	Super Silicone Tube 2455x30mm (Transparent)		
SW-420010	Antenna Cup		
SW-420026	S350/S350T Series Option Air Filter Extension Adapter		
SW-510091	SWORKz Original Logo Sticker (2PC)		
SW-540003	SWORKz Cable Straps for 1/8 Buggy Airfilter (10PC)		
SW-610004	Air Filter Foam Set		
SW-610019	S35-3 Series Servo Saver Spring Dusty Protect Sponge (2PC)		
SW-610020	S35-3 Series Center Big Bore Plastic Diff. Case Gasket (3PC)		
SW-610023	S35-4 HET Diff. Gasket (0.4T)(4PC)		
SW-101004	Washer 3.5X10X0.2mm		
SW-101010A	M3 Countersunk Washer (GM)		
SW-101011	M2.6x6xT0.6mm		
SW-101013	3mm Spring Washer		
SW-101015	M5x8xT0.4mm		
SW-101016	M5x8xT0.8mm		
SW-101018	SHIM 13x16x0.2mm		
SW-101019	SHIM 6.0x10.0x0.2mm		
SW-101020A	S350 Sries 3mm Countersunk Washers (GM)		
SW-101021	M3x8xT0.8mm		
SW-101039	SWORKz HET Diff Steel Washer 5x12x0.3mm (10PC)		
SW-103001	M3 Nut Lock		
SW-103003A	Flange M3 Nut Lock (GM)		
SW-103004	M2.5mm Nut Lock		
SW-104004	M3x3mm Set Screw		
SW-104005	M3x4mm Set Screw		
SW-104010	M5x4mm Set Screw (Flat Bottom)		
SW-104011	M4x4mm Set Screw (Flat Bottom)		
SW-105001	M3x8mm Cap Screw		
SW-105005	M3x12mm Cap Screw		
SW-105006A	M3x28mm Cap Screw full thread		
SW-105007A	M4x8mm I-Head Screw Thin		
SW-105013A	M3x25mm Cap Screw		
SW-105018	M2x6mm Cap Head Screw		
SW-106001	M3x8mm Hex Soket OH/TP Screw		
SW-106002	M3x10mm Hex Soket OH/TP Screw		
SW-106003	M3x16mm Hex Soket OH/TP Screw		
SW-106006	M3x20mm Hex Soket OH/TP Screw		
SW-106007	M3x12mm Hex Soket OH/TP Screw (HT)		
SW-106008	M3x12mm Hex Soket OH/TP Screw		
SW-106009	M3x25mm Hex Soket OH/TP Screw		
SW-106013	M2.5x8mm 1.5mmHex Soket OH/ST Screw		
SW-106015	M3x5mm Hex Soket OH/TP Screw		
SW-106020	M2.5x5mm 1.5mmHex Soket OH/ST Screw		
SW-106021A	S35 Series M4x10mm Hex Soket OH/TP Set Screw		
SW-108001	M3x12mm FH/ST HEX Screw		
SW-108003	M3x10mm FH/ST HEX Screw		
SW-108005	M3x14mm FH/ST HEX Screw		
SW-108006	M3x8mm FH/ST HEX Screw		
SW-108007	M3x6mm FH/ST HEX Screw		
SW-108008	M3x35mm FH/ST HEX Screw		
SW-108010	M4x10mm FH/ST HEX Screw		
SW-108011	M4x12mm FH/ST HEX Screw		
SW-108012	M4x16mm FH/ST HEX Screw		
SW-108013	M4x8mm FH/ST HEX Screw		
SW-108019	M2.6x6mm FH/ST HEX Screw		
SW-108029	M2.0x4.6mm FH/ST HEX Screw (1.5mm HexHead)		
SW-115003A	SWORKz Tornado Clutch Spring II (1.0mm)		
SW-115004A	Servo Saver Spring		

## Option Part List

Item No.	Part Name	Item No.	Part Name
SW-2501116	SWORKz High Done Force Wing Set (BK)(Fit S350)	SWC-115192	S35 Series Competition Black Line Rear Shock Spring (RM2-Dot)(80X1.6X10.25)
SW-2501116A	SWORKz High Done Force Wing Set (BK)	SW-118001-25	S35-T2/T2e Front Sway Bar 2.5mm
SW-2501116AFY	SWORKz High Done Force Wing Set (FY)	SW-118001-27	S35-T2/T2e Front Sway Bar 2.7mm
SW-2501116AWH	SWORKz High Done Force Wing Set (WH)	SW-118002-27	S35-T2/T2e Rear Sway Bar 2.7mm
SW-2501114-4	S35-3/S350 Nitro Series Center Brake Disk Holder	SW-118002-30	S35-T2/T2e Rear Sway Bar 3.0mm
SW-2501126	Ail Filter Set		
SW-2501529H	S35/S350 Series Hard Plastic Chassis Brace Set		
SW-2503260FO	S353 Series Colorful Plastic Inserts Set (FO)		
SW-2503260FY	S353 Series Colorful Plastic Inserts Set (FY)		
SW-2503260LB	S353 Series Colorful Plastic Inserts Set (SB)(2 Set)		
SW-210079AH	S35-4 Plastic Center Big Bore HET Diff Case (Hard)		
SW-210091H	S35-4 Plastic Front/Rear Big Bore HET Diff Case (Hard)		
SW-218005	S35-3/4 Series HET Center Big Bore Diff. Set (47T)		
SW-218014	S35-T/S35-TE Series HET Diff. Combo Set		
SW-228008WH	SWORKz 1/8 Off Road Formula 2.0 Race Wing (WH)		
SW-228008FY	SWORKz 1/8 Off Road Formula 2.0 Race Wing (FY)		
SW-300049	SWORKz S35-3/S350 Series Rear Stainless Chassis End Protection (2PC)		
SW-330006A	Tornado Clutch Shoes (2Set)		
SW-330115	Steering Knuckle Pivot Ball Turnbuckle		
SW-330116	14mm Knuckle Pivot Ball		
SW-330125A	S350 Series Aluminum Rear Upper Sus. Arm Ball Stud (4PC)		
SW-330134A	S350 Series Aluminum Shock Ball Stud (4PC)		
SW-330136A	S350 Series Aluminum Sway Bar Ball Stud (4PC)		
SW-330168A	S35-3 Series Rear Chassis Blance wight 15g (2PC)		
SW-330202	S-WORKz Turbo Tornado Fly Wheel Set		
SW-330398A	SWORKz S350 Series Pro Wheel Nut (GM)		
SW-330420	S350 Series Knuckle Pivot Ball Balance Nut (5.5g) (2PC)		
SW-330424	S350 Series Aluminum Wing Holder (RED)		
SW-330424B	S350 Series Aluminum Wing Holder (BK)		
SW-330424G	S350 Series Aluminum Wing Holder (GM)		
SW-330505A	S35 Series Lightened Wheel Hub for 8mm Axil (L6.5mm)		
SW-330506A	S35 Series Lightened Wheel Hub for 8mm Axil (L5.0mm)		
SW-330564A	S35 Series BBS System Shock Piston 1.5mmX6 Holes (BK)		
SW-330565	S350 BBS System Shock Piston 1.3mmX8 Oblique Holes (2PC)		
SW-330566	S350 BBS System Shock Piston 1.2mmX8 Oblique Holes (2PC)		
SW-330568	S350 Buggy Series Aluminum Center Diff. Mount		
SW-330767	S35-3 Series T-7075 Aluminum F-Center Dive Shaft (88mm)		
SW-330777B	S35-4 Series Aluminum Steering Linkage Ball Stud 7mm (L7)(4PC)		
SW-338070A	S35 Series Rear Upper Arm Aluminum Ball Stud (2PC)		
SW-338078-25	SWORKz Uni-Design 2-Way System Aluminum Steering Servo Horn 25T		
SW-338078-23	SWORKz Uni-Design 2-Way System Aluminum Steering Servo Horn 23T		
SW-338079-25	SWORKz Uni-Design Aluminum Throttle Servo Horn 25T		
SW-338079-23	SWORKz Uni-Design Aluminum Throttle Servo Horn 23T		
SW-340029-15	S35-T2/e Pro-composite Carbon Front Lower Arm Cover (1.5mm)(2PC)		
SW-340030-15	S35-T2/e Pro-composite Carbon Rear Lower Arm Cover (1.5mm)(2PC)		
SW-400022A-M	S35 Series BBS System Pro Shock Bladder (Medium)(8PC)		
SW-400024S	S35 Series BBS System Hex-Cell Shock Bladder(Soft)(4PC)		
SW-410023	Air Filter Adapter		
SWC-115107	S350 Competition Shock Spring A-2 (75X1.4X7.25)(Red)		
SWC-115109	S350 Competition Shock Spring B-2 (90X1.4X8.5)(Pink)		
SWC-115110	S350 Competition Shock Spring C-1 (75X1.5X7.75)(SkyBlue)		
SWC-115118	S350 Competition Shock Spring E-3 (90X1.5X8.5)(Blue)		
SW-115026A	SWORKz Tornado Clutch Spring II (1.1mm)(GR)		
SW-115027A	SWORKz Tornado Clutch Spring II (1.2mm)(GD)		
SW-115077A	SWORKz Tornado Clutch Spring II (0.9mm)(BK)		
SW-116006A	High Performance Rubber Cover Ball Bearing 8x16x5mm (10PC)		
SW-116010B	High Performance Ball Bearing 5x10x4mm (coffee)(4PC)		
SW-116019C	SWORKz High Performance 5x13x4mm Ball Bearing (Rubber Case)(4PC)		
SWC-116006C	SWORKz Competition 8x16x5mm Ball Bearing (Metal Case)(6PC)		
SWC-116010C	SWORKz Competition 5x10x4mm Ball Bearing (Metal Case)(6PC)		
SWC-116019A	SWORKz Competition 5x13x4mm Ball Bearing (Metal Case)(4PC)		
SWC-116019B	SWORKz Competition 5x13x4mm Ball Bearing (Metal Case/Japan)(4PC)		
SWC-210088	S35-3 Nitro Series Pro-composite Carbon One Unit Radio Tray Set		
SWC-338006	SWORKz Tornado Hi-Performance Lightened Clutch Bell (13T)		
SW-338036	SWORKz 1/8 Nitro Series Pipe Spring Lock (1 Set)		
SW-338075	S35-4 Series T7 Aluminum Rear Wheel Hub (R=L)(2PC)		
SWC-218020-6LD	S35 Series 1-Unit-Fit Aluminum Engine Mount Set (6 Degree Lay-Down)		
SWC-218020-4LD	S35 Series 1-Unit-Fit Aluminum Engine Mount Set (4 Degree Lay-Down)		
SWC-338095	S35 Series 1-Unit-Fit Aluminum Engine Mount (6 Degree Lay-Down)		
SWC-338096	S35 Series 1-Unit-Fit Aluminum Engine Mount (Upper)(2PC)		
SWC-338097	S35 Series 1-Unit-Fit Aluminum Engine Mount (4 Degree Lay-Down)		
SWC-115163	S35 Series Black Competition Front Shock Spring (M4-Dot)(75X1.6X8.75)		
SWC-115164	S35 Series Black Competition Front Shock Spring (M3-Dot)(75X1.6X9.0)		
SWC-115165	S35 Series Black Competition Front Shock Spring (M2-Dot)(75X1.6X9.25)		
SWC-115166	S35 Series Black Competition Rear Shock Spring (L4-Dot)(86X1.6X10.25)		
SWC-115167	S35 Series Black Competition Rear Shock Spring (L3-Dot)(86X1.6X10.5)		
SWC-115169	S35 Series Black Competition Front Shock Spring (S4-Dot)(70X1.6X8.25)		
SWC-115171	S35 Series Black Competition Front Shock Spring (S2-Dot)(70X1.6X8.75)		
SWC-115190	S35 Series Competition Black Line Rear Shock Spring (RM4-Dot)(80X1.6X9.75)		
SWC-115191	S35 Series Competition Black Line Rear Shock Spring (RM3-Dot)(80X1.6X10.0)		

# S35-F12

**1/8 OffRoad Nitro Power Pro Truggy**



**SPEEDMASTER HOBBY CO., LTD.**

TEL: +886-3-538-7638

FAX: +886-3-538-7328

No.42, Ruiguang St., Xiangshan Dist.,  
Hsinchu City 300, Taiwan (R.O.C.)

[www.sworckz.com](http://www.sworckz.com)