

ICON² WORLDS

Driver: _____ Track: _____ Event: _____
 Date: _____ Qualifying: _____ Final: _____ Best Lap: _____

TRACK TYPE

Grip Level High Medium Low
 Type Tight Open Mixed
 Condition Flat Bumpy Mixed
 Surface Tarmac (Asphalt) Carpet
 Track Temp _____ °C
 Weather _____

Notes:

TYRES

Tyres _____
 Sizes Front: _____ mm Rear: _____ mm
 Additive/Cleaner _____
 Additive Time Front: _____ mins Rear: _____ mins
 Additive Coverage Front: _____ mm
 Heating Info F: _____ °C mins R: _____ °C mins

Notes:

FRONT

KEY: CF = Carbon Fibre, AL = Aluminium, P = Plastic, F = Front, R = Rear
 H = High, L = Low, Y = Yes, N = No, V = Vertical, H = Horizontal

Ride Height _____ mm
 Droop _____ mm
 Toe Out _____ deg St Links _____ mm
 Servo Horn Height _____ mm Saver
 Steering Travel _____ in _____ out
 Castor _____ deg
 Track Width _____ mm

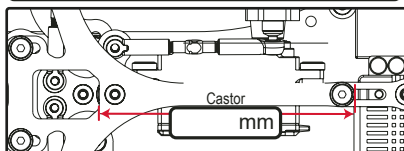

Notes:

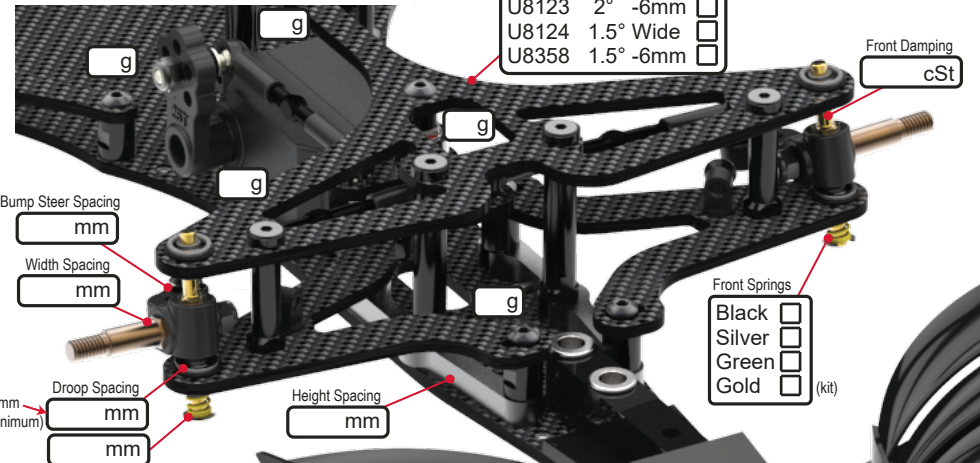

REAR

KEY: CF = Carbon Fibre, AL = Aluminium, P = Plastic, F = Front, R = Rear
 H = High, L = Low, Y = Yes, N = No, V = Vertical, H = Horizontal

Ride Height _____ mm
 Droop _____ mm
 Track width _____ mm
 Diff Type Gear Ball Spool
 Diff Oil (Gear Diffs) _____ cSt

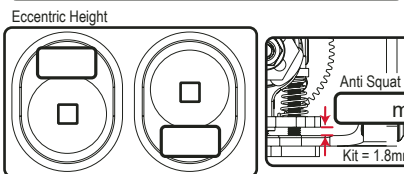

Notes:

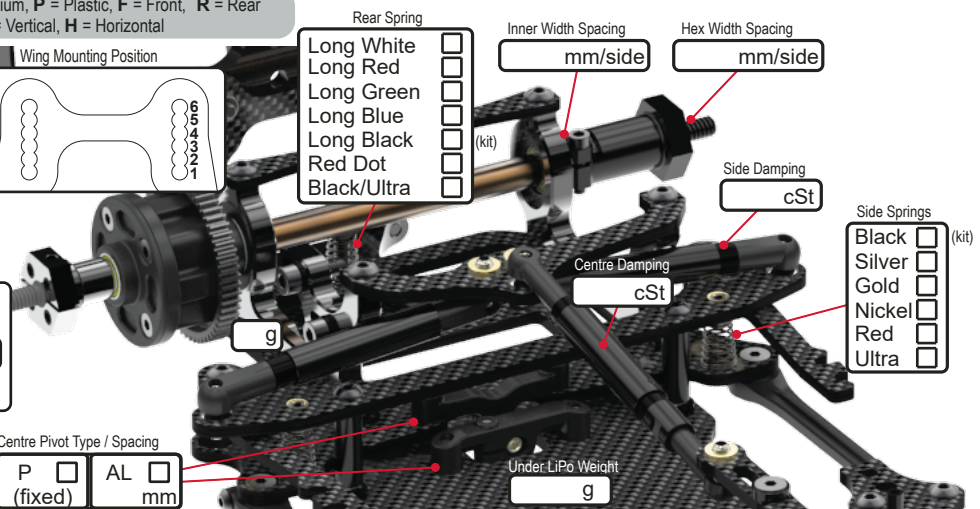

BODYSHELL

Body _____
 Rear Wing _____
 Rear Wing Height _____ mm
 Front Wing _____
 Front Wing Flaps _____
 Front Post Hole # _____
 Front Post Hanger # _____
 Rear Post Hole # _____
 Rear Post Hanger # _____
 Wing Offset Rwrld _____ mm
 Body Weight _____ g

CHASSIS

Chassis AL CF
 Wheelbase
 Short Long
 Total Weight _____ g
 Weight Distribution
 F : R
 Mass Dampers
 F _____ cSt
 R _____ cSt
 Springs _____
 Notes:

ELECTRONICS

E.S.C. _____
 Servo _____
 RX _____
 LiPo _____
 Motor _____
 Rotor Dia. _____ mm
 Timing _____ deg
 Gear Pitch 48 64
 Pinion _____ t
 Spur _____ t
 Ratio _____

Notes: