

INSTRUCTION MANUAL

9899 VIPER[®]

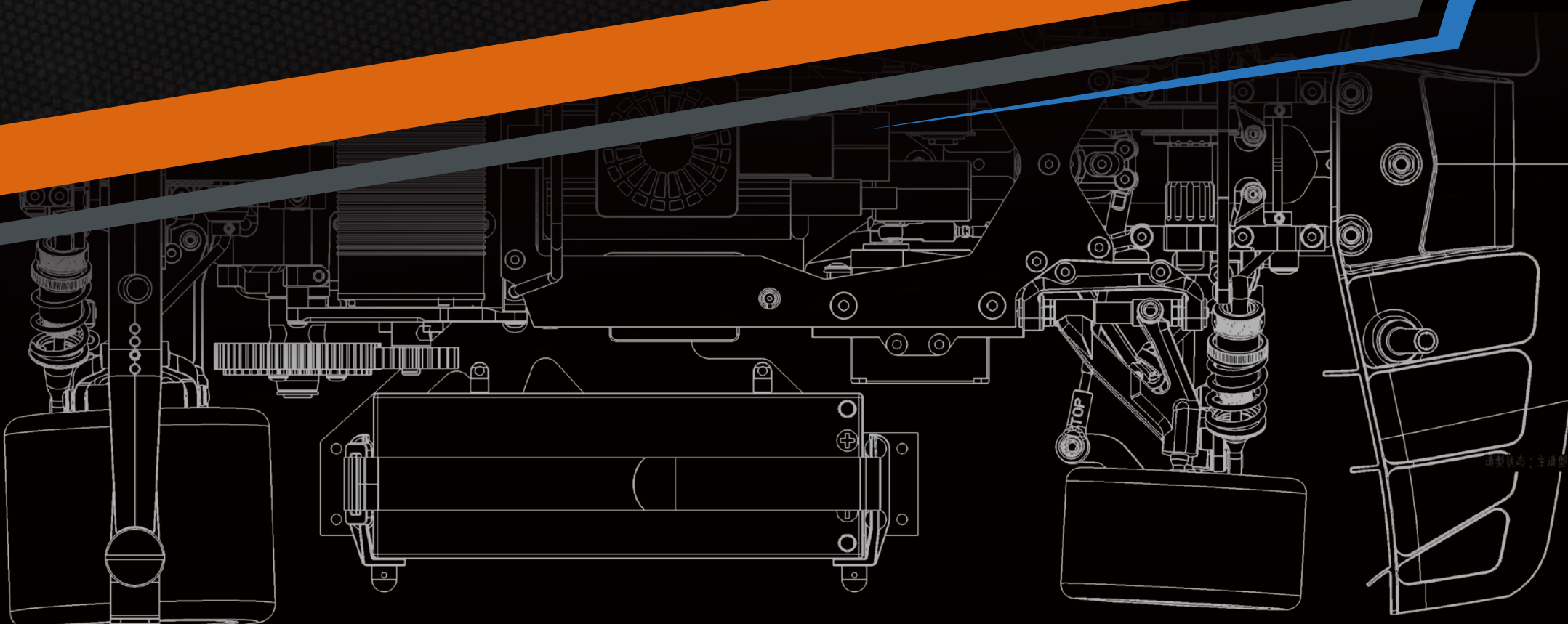

請認明：全球型

SERPENT

INTRODUCTION

The Serpent Viper 989E is designed to be a world champion, while still being easy to use, assemble, and set up. The Serpent Viper 989E offers state of the art specifications and leads the way in chassis design, using all the knowledge we have from 1/8 scale racing into this design too. Continuously pushing the performance envelope, Serpent's engineers have added new and innovative features that help take your Serpent Viper 989E into the winner's circle.

Designed by Michael Salven

Team Serpent
Multiple World Champions

INSTRUCTIONS

Serpent's long tradition of excellence extends to the instruction manuals, and this instruction manual is no exception. The easy-to-follow layout is richly illustrated with 3D-rendered full-color images to make your building experience quick and easy. Following the instructions will result in a well-built, high-performance race-car that will soon be able to unleash its full potential at the racetrack. The kit includes bags, with bag numbers, which refer to the same step in the manual. Open only the indicated bag(s) per step and finish that part of the assembly. Remaining parts will be needed later on in the assembly process.

PLASTIC PARTS

The Serpent moulded parts are very durable and hard. When assembling longer screws in new composite parts, make sure to use new hex bits in your (power) tools. Pre-threading also helps to avoid screw damage.

SETUP

In certain assembly steps you need to make basic adjustments, which will give you a good initial setup for your Serpent Viper 989E. Fine-tuning the initial setup is an essential part of building a high-performance racecar like your Serpent Viper 989E.

EXPLODED VIEWS AND PARTS LIST

The exploded views and parts lists for the Serpent Viper 989E are presented in the Reference Guide section in the back of this manual. The exploded views show all the parts of a particular assembly step along with the Serpent part number and hotlink to the Serpent website. Part numbers in orange indicates that this part is an optional. Optionals part names and numbers are showed below.

CUSTOMER SERVICE

Serpent has made a strong effort to make this manual as complete and clear as possible. Additional info may be published in our website: www.serpent.com or you may ask your dealer or the Serpent distributor for advice, or email Serpent direct: info@serpent.com. The Serpent Facebook, Twitter and Youtube pages give additional means of support and communications.

SAFETY

Read and take note of the 'Read this First section' before proceeding to assemble the car-kit. This car-kit is intended for persons aged 16 or older.

READ THIS FIRST!

- This is a highly technical hobby product, intended to be used in a safe racing environment. This car is capable of speeds in excess of 80 km/h or 50mph. Please follow these guidelines when building and operating this model.
- Parental guidance is required when the builder/user of this car is under 16.
- Follow the building instructions. If in doubt, contact your dealer or importer.
- Be sure to use the proper tools when assembling the car. Always exercise caution when using electric tools, knives and other sharp objects.
- Be careful when using liquids like lubrication oil, fuel or glue. Do not swallow.
- Follow the manufacturer's instruction in case you experience irritation after using the product.
- Be careful when operating the car. Stay away from any rotating parts such as wheels, gears and transmission. Stay away from motor, engine and exhaust pipe system or speedo during and immediately after use, as these parts may be very hot. We advise to use protective hand gloves.
- Only operate this car in a safe environment, like a special racing track or a closed parking lot. Avoid using this car on public roads, crowded places or near infants.
- Before operating this car, always check the mechanical status of the car. Also check that the transmitter and receiver frequencies correspond and are not used by any other racer at the same time. Check that the batteries of the transmitter and receiver- are fully charged.
- After use, always check all the mechanics of the car. We advise to clean the car immediately after use, and inspect the parts for wear or fractures. Replace when necessary. Do not use water, methanol, thinner or other solvents to clean the car.
- Empty the fuel tank (depending on model) if needed and disconnect the receiver battery.
- Store the car in a dry and heated place to avoid corrosion of metal parts.
- Avoid using this car in wet conditions as the water will cause corrosion on the metal parts and bearings and these parts will cease to function properly. If driven in the wet, ensure that all the electric equipment is waterproofed and after use, that all moving parts are dried immediately.

CONTENTS

• REAR ASSEMBLY.....	4
• FRONT ASSEMBLY.....	14
• CENTER ASSEMBLY.....	22
• MOTORMOUNT ASSEMBLY.....	24
• RADIO ASSEMBLY.....	25
• SHOCKS ASSEMBLY.....	26
• FINAL ASSEMBLY.....	28
• EXPLODED VIEWS.....	33
• TEAM SERPENT NETWORK.....	41

LINES DESCRIPTION

Each step contains a variety of numbers, lines, and symbols. The numbers represent the order in which the parts should be assembled. The lines are described below.



Step number; the order in which you should assemble the indicated parts



Length after assembly



Assembly path of one item into another



Group of items (within lines) should be assembled first



Direction the item should be moved



Glue one item to another



Connect one item to another



Gap between two items



Press/Insert one item into another

ICONS DESCRIPTION

Each step contains a variety of symbols described below.



Carefull, read and check very well.



Apply a small amount of cyano glue. Use wear protection for eyes and hands.



Detail view to explain assembly or order of parts better.



Default set-up: This symbol indicates the default setup.



Grease: apply a small amount of grease to the parts shown.



Silicone grease: apply a small amount of grease to the parts shown.



Thread lock: apply a small amount on the parts shown. Before to apply the threadlock, make sure to degrease the parts very well, as otherwise the threadlock will not work.



Silicone oil: use the indicated silicone oil for the shocks and differentials.



Left and right parts should be assembled in the same way.



Parts or items not included in the kit.



Optional part, not standard in the kit.

STEP 1

BAG 1

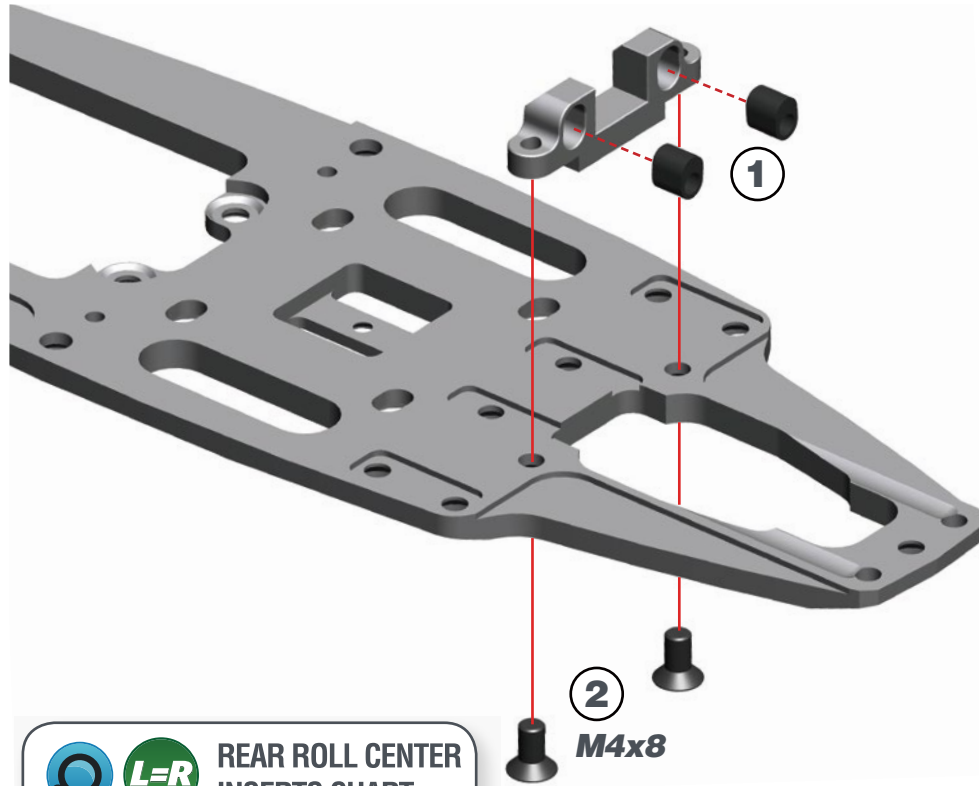

L=R

REAR ROLL CENTER
INSERTS CHART

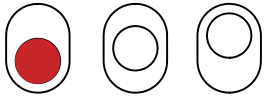

DEF.
SETUP

2
M4x8

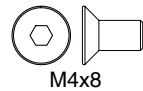

M4x8

STEP 2

L=R

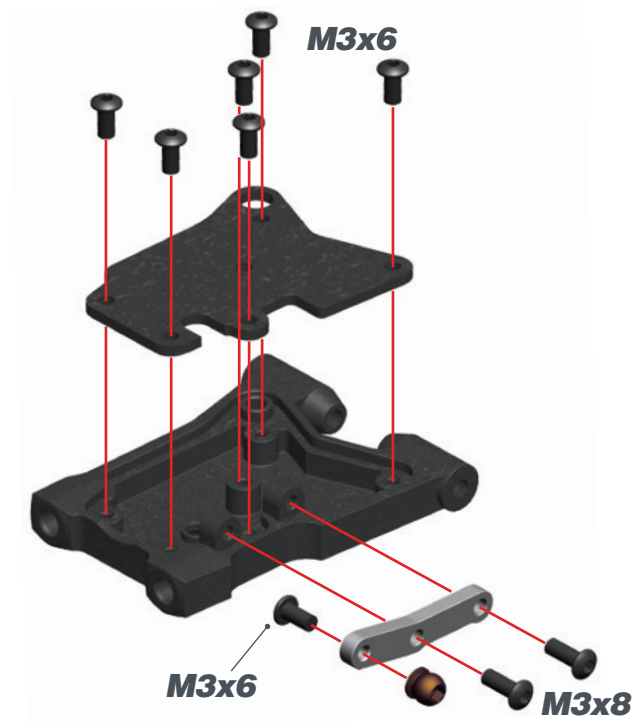

M3x6

M3x6

M3x8

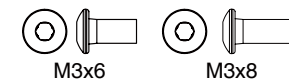

M3x6

M3x8

STEP 3

STEP 4

L=R

M4x10



L=R REAR ANTIROLL BAR ROD LENGTH

32.5mm



M4x10

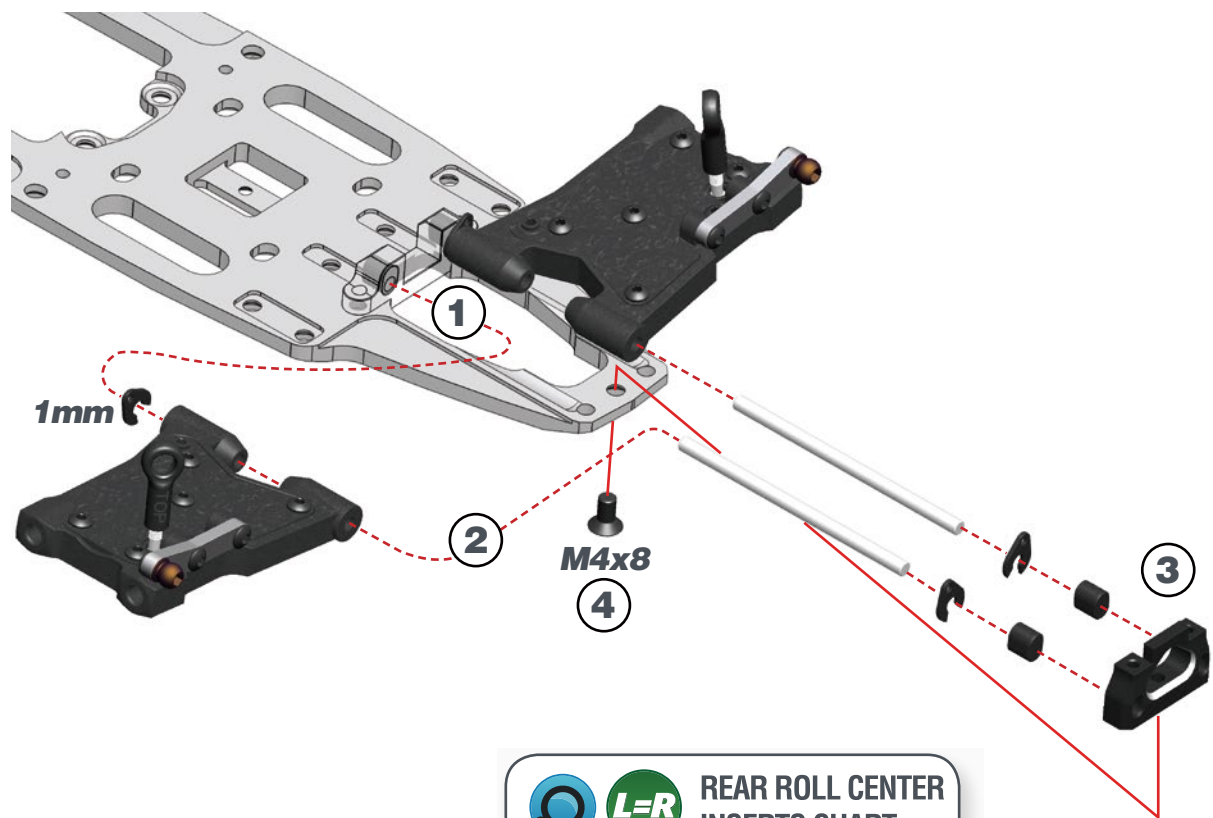

L=R REAR ROLL CENTER INSERTS CHART

DEF. SETUP



M4x8

STEP 5

BAG 2

STEP 6

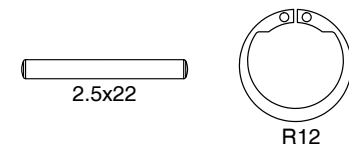
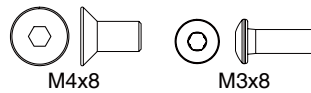
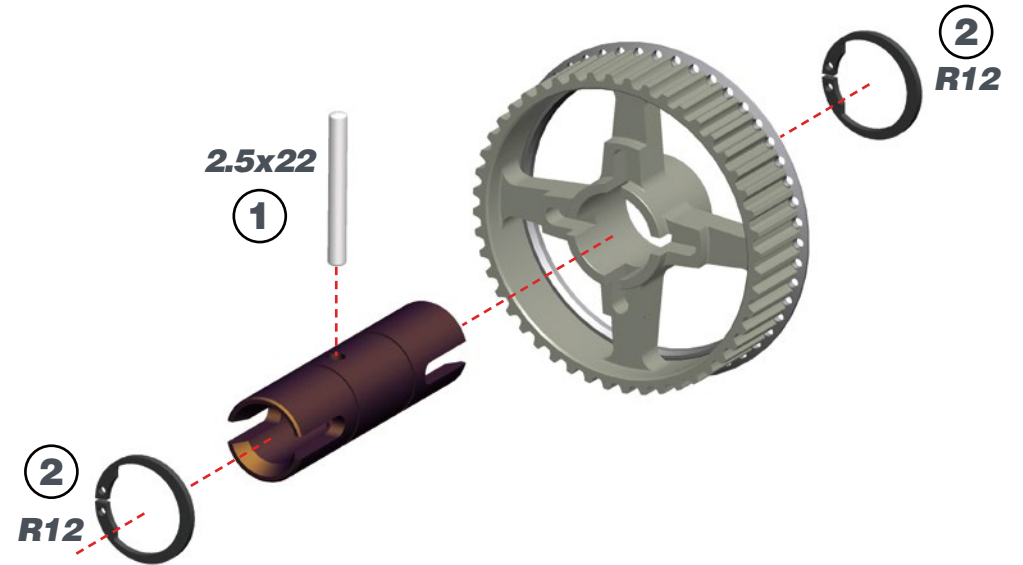
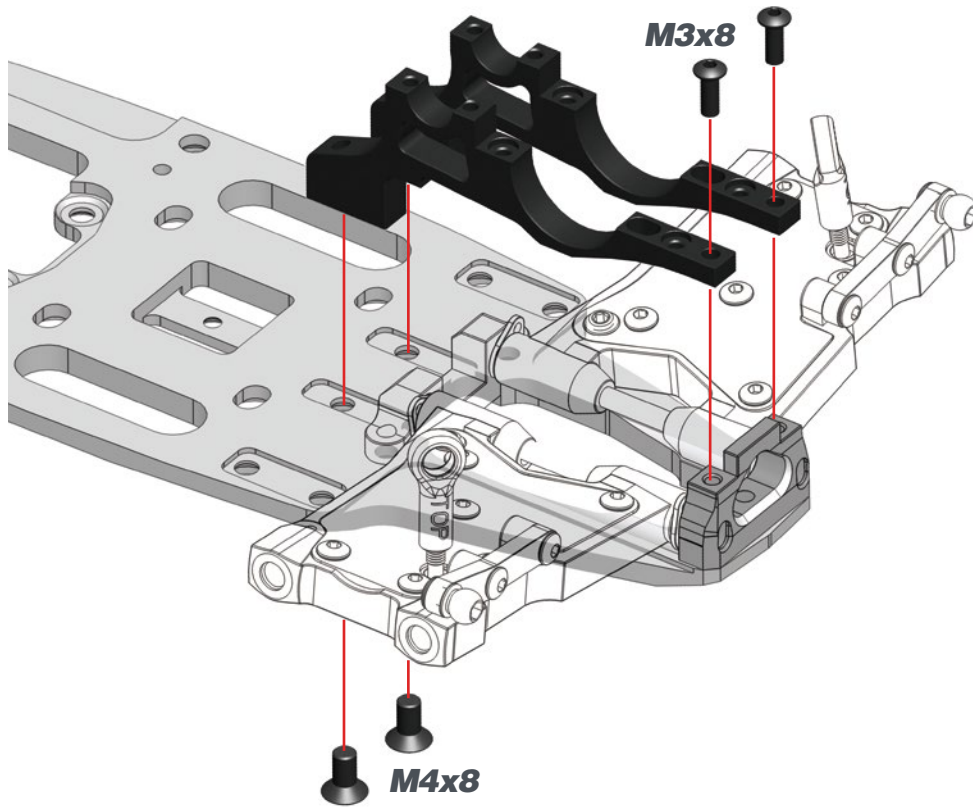

STEP 7

REAR SOLID AXLE EXCENTERS
 Note that the rear solid axle excenters are not symmetrical and are marked with L (=left) and R (=right).

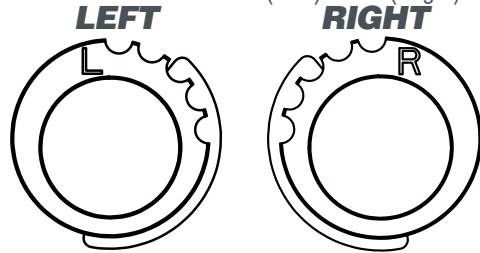

REAR BELT TENSION
 Use the central slot as starting position

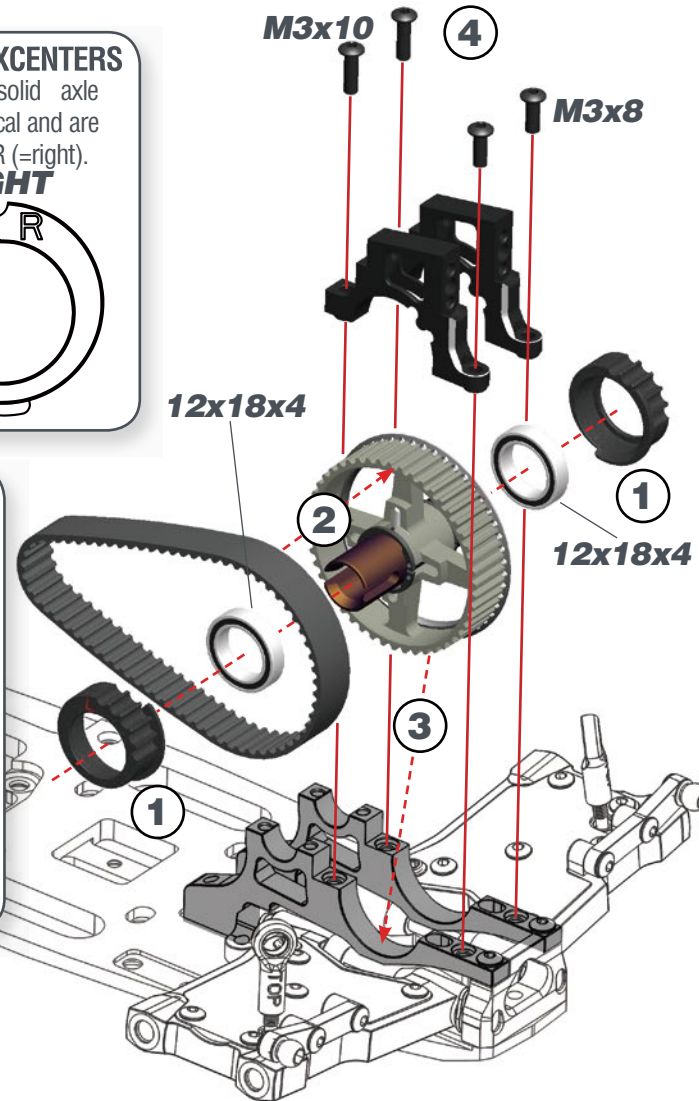
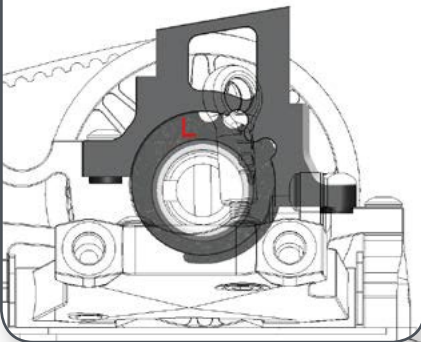

STEP 8

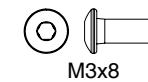
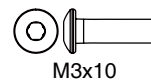
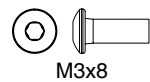
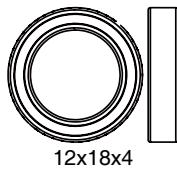
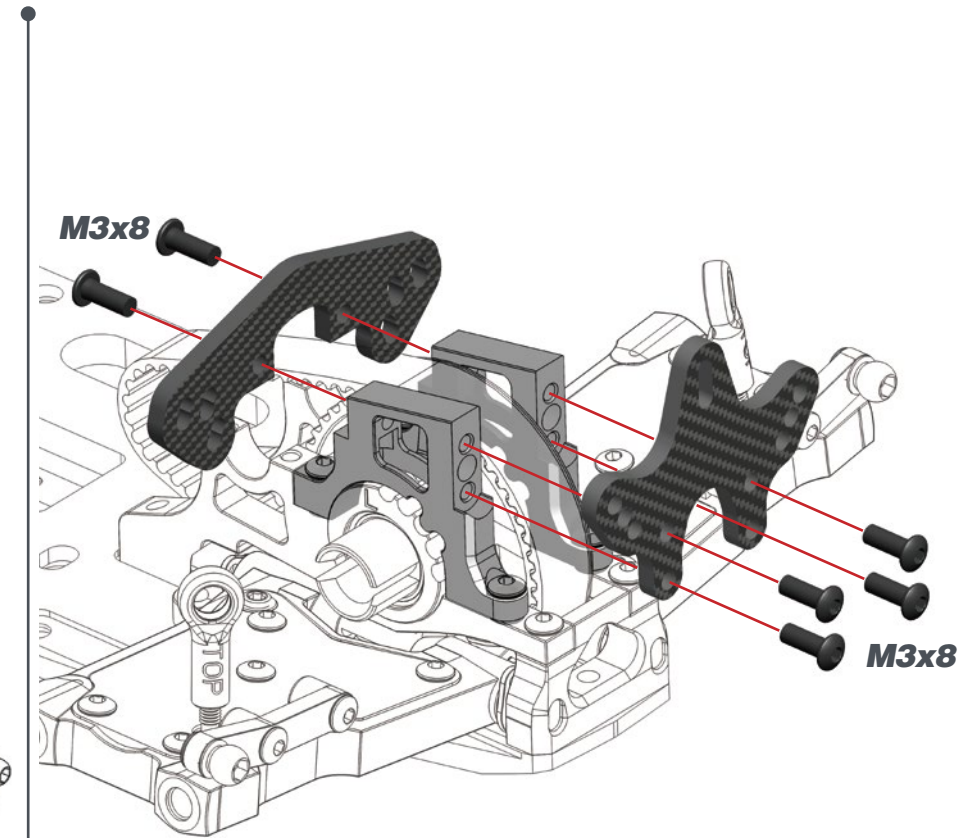

STEP 9

9.1

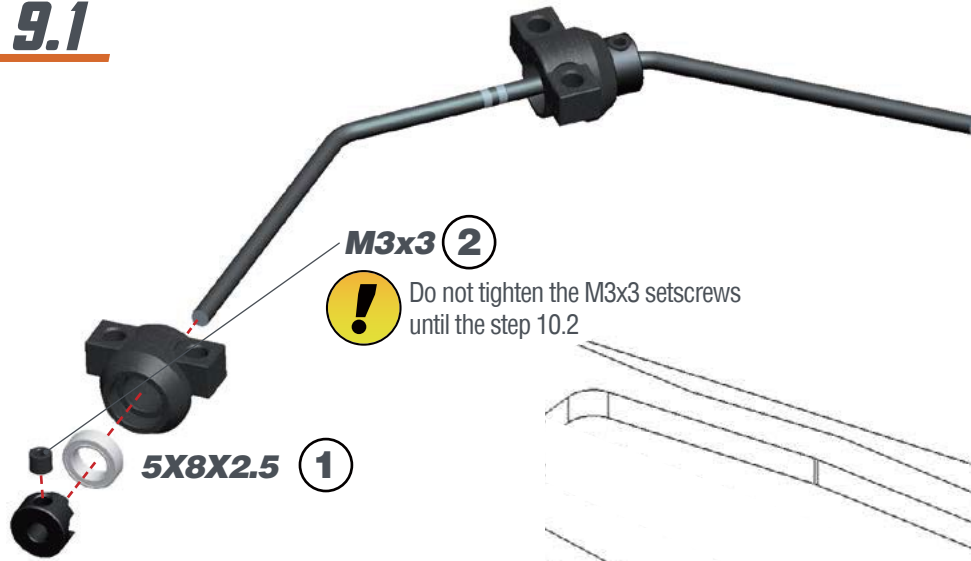

M3x3 (2) Do not tighten the M3x3 setscrews until the step 10.2

5x8x2.5 (1)

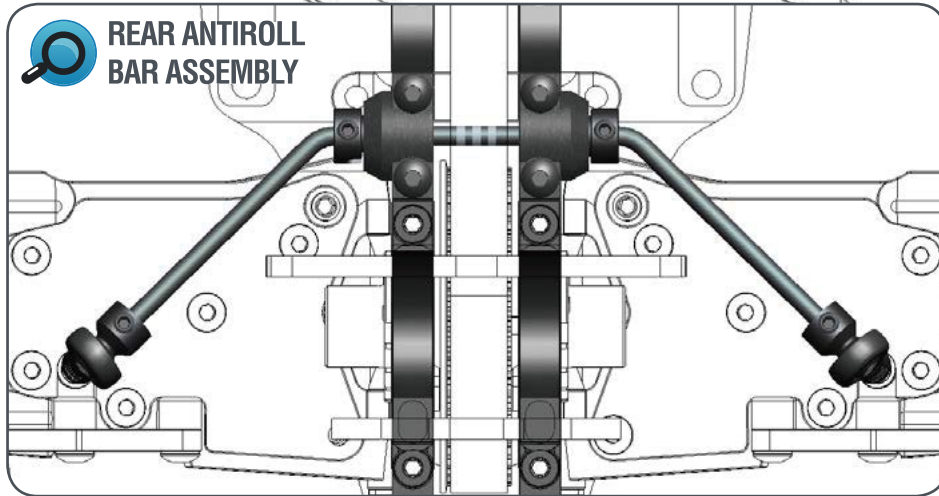

9.2

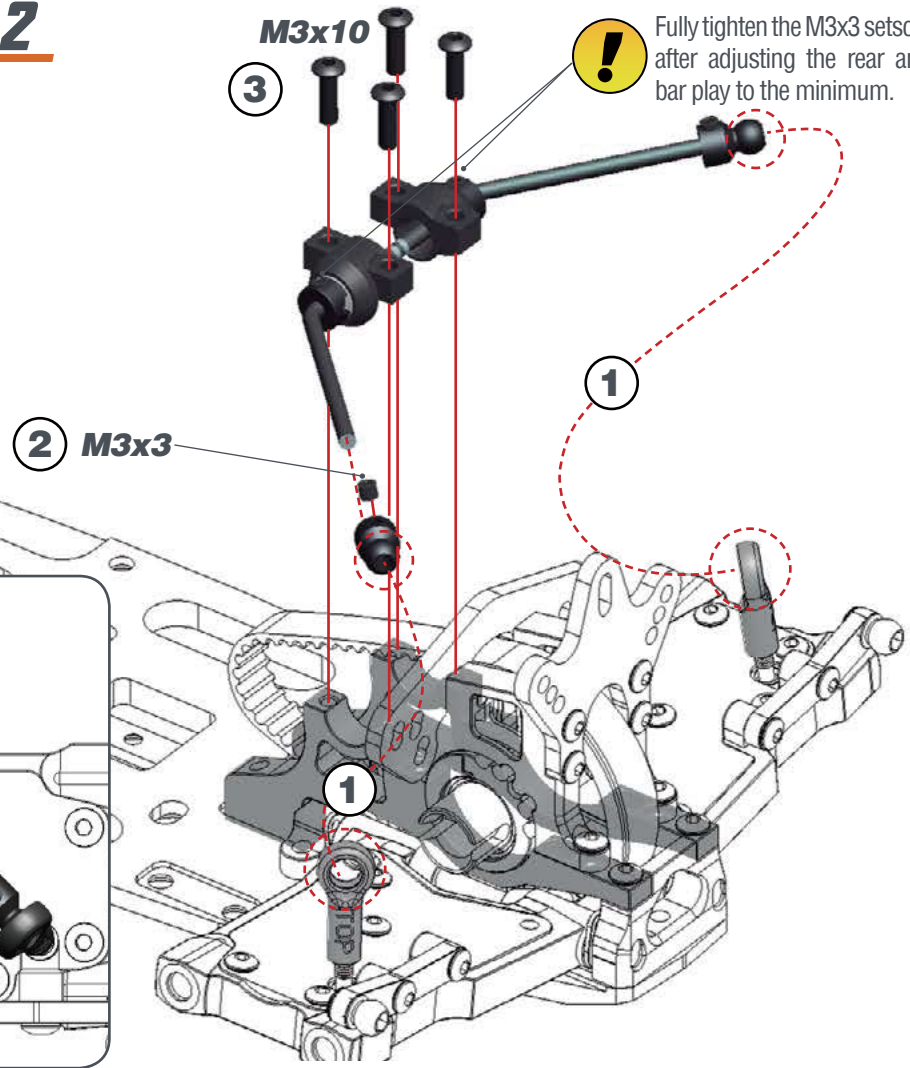

M3x10 (3) Fully tighten the M3x3 setscrews after adjusting the rear antiroll bar play to the minimum.

(2) **M3x3**

(1)



STEP 10 BAG 3

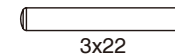
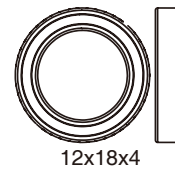
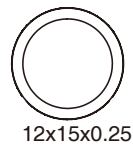
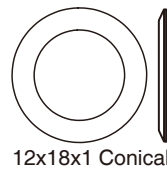
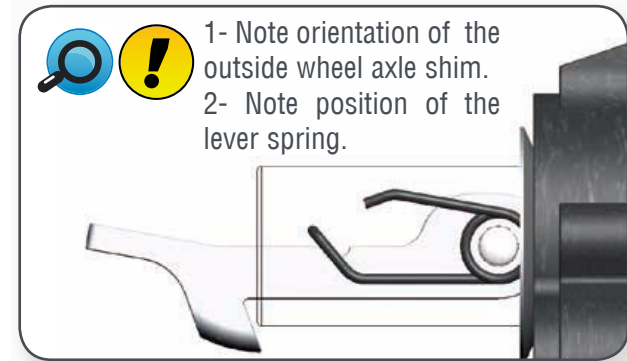
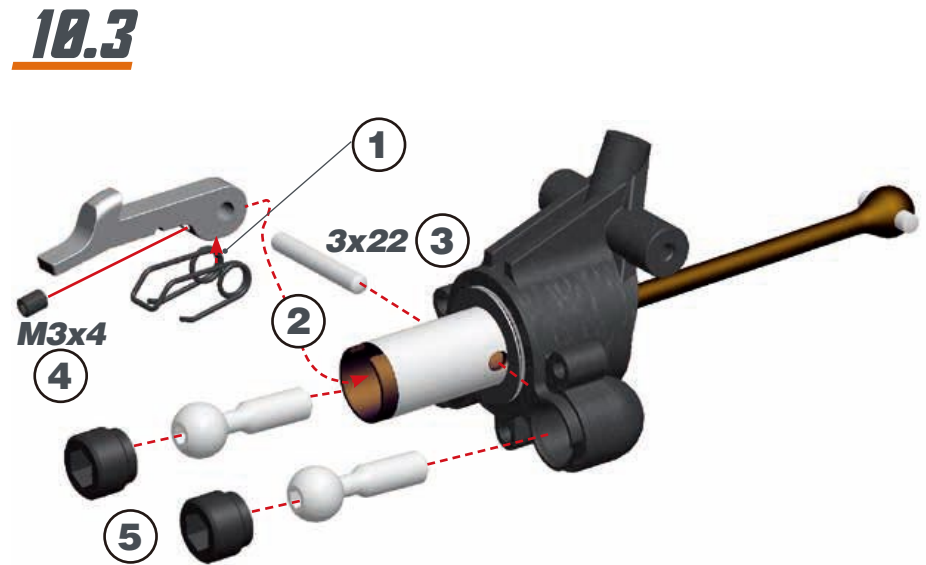
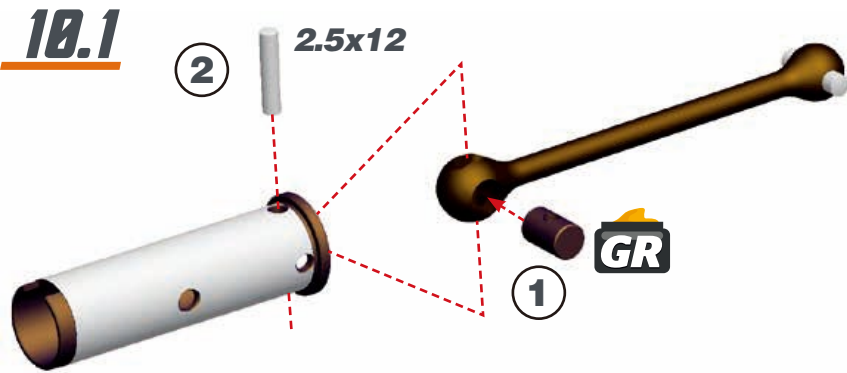

STEP 11

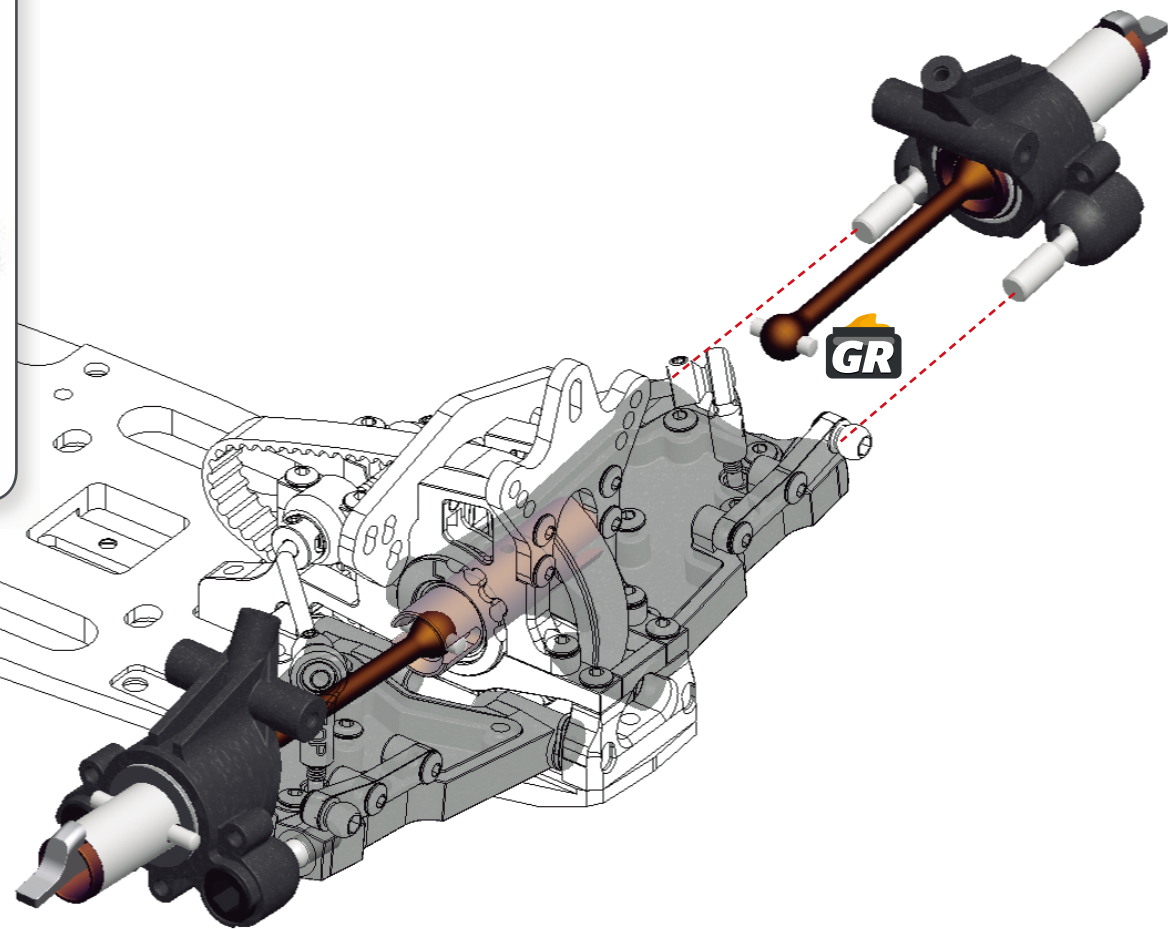
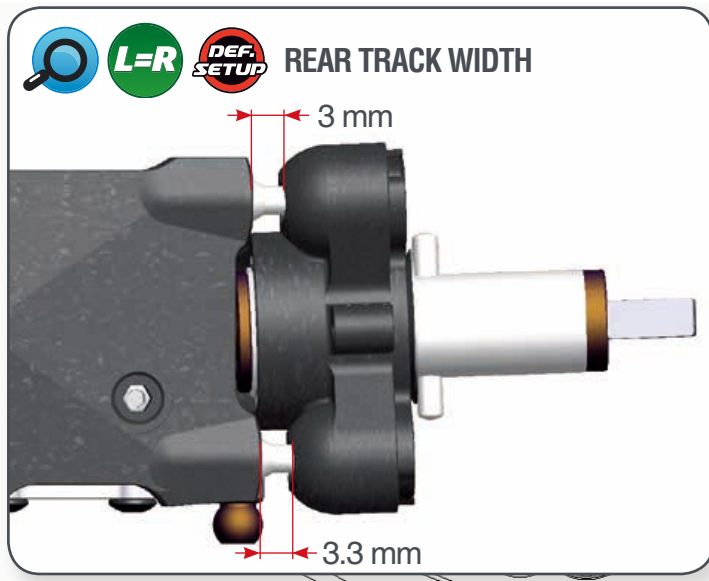

STEP 12

12.1

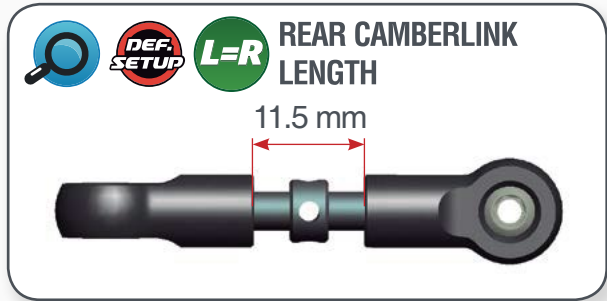

12.2

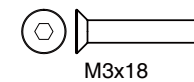
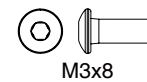
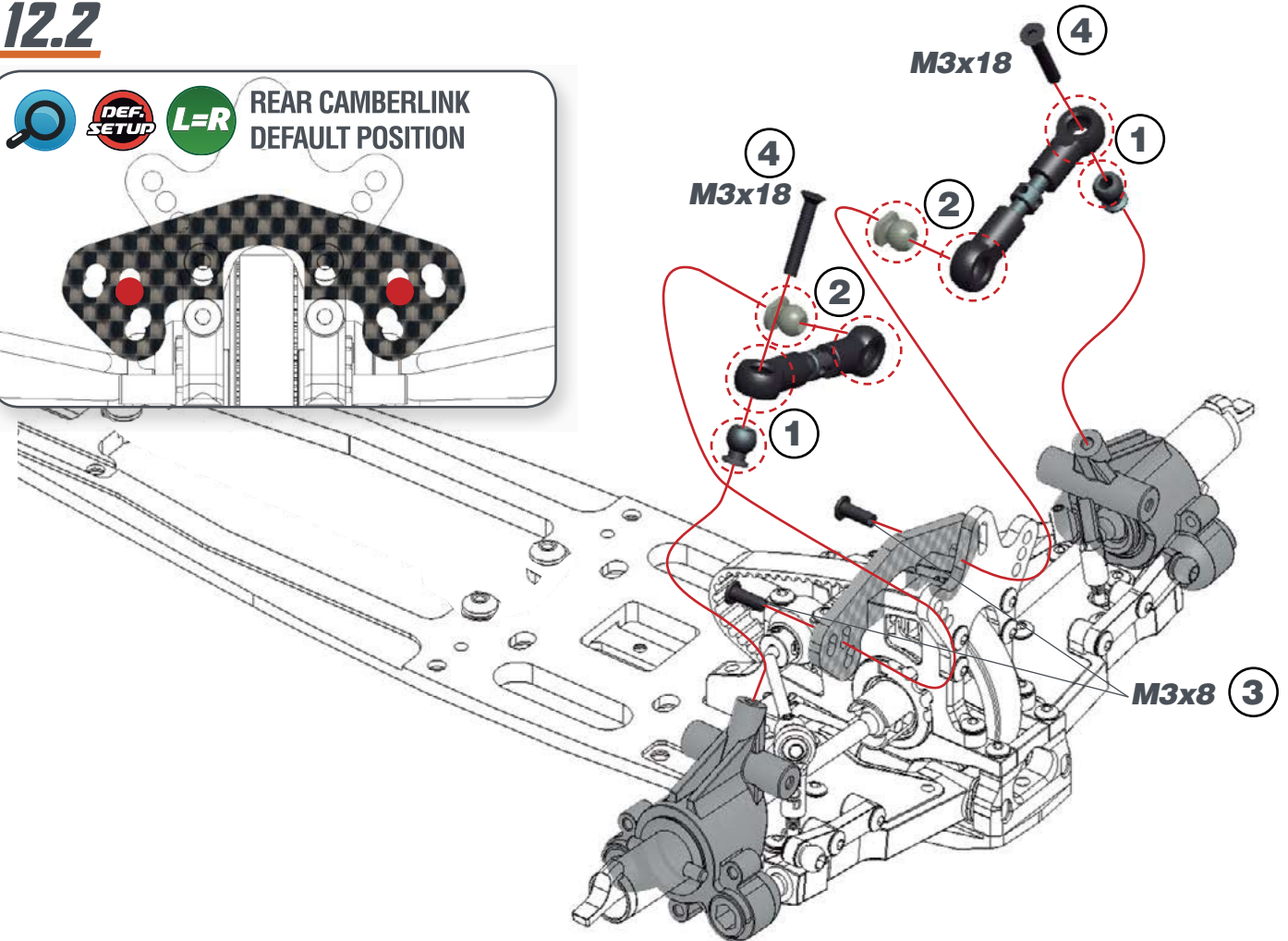
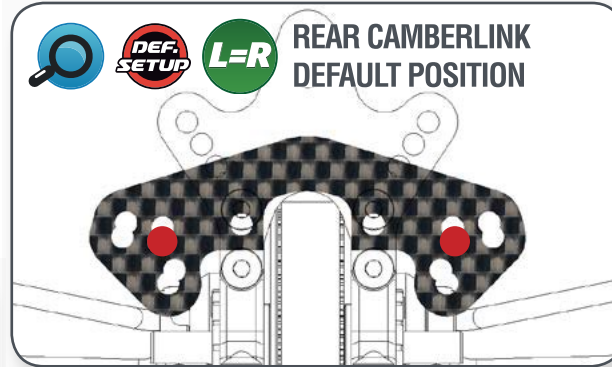

STEP 13 BAG 4

13.1

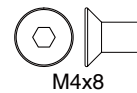
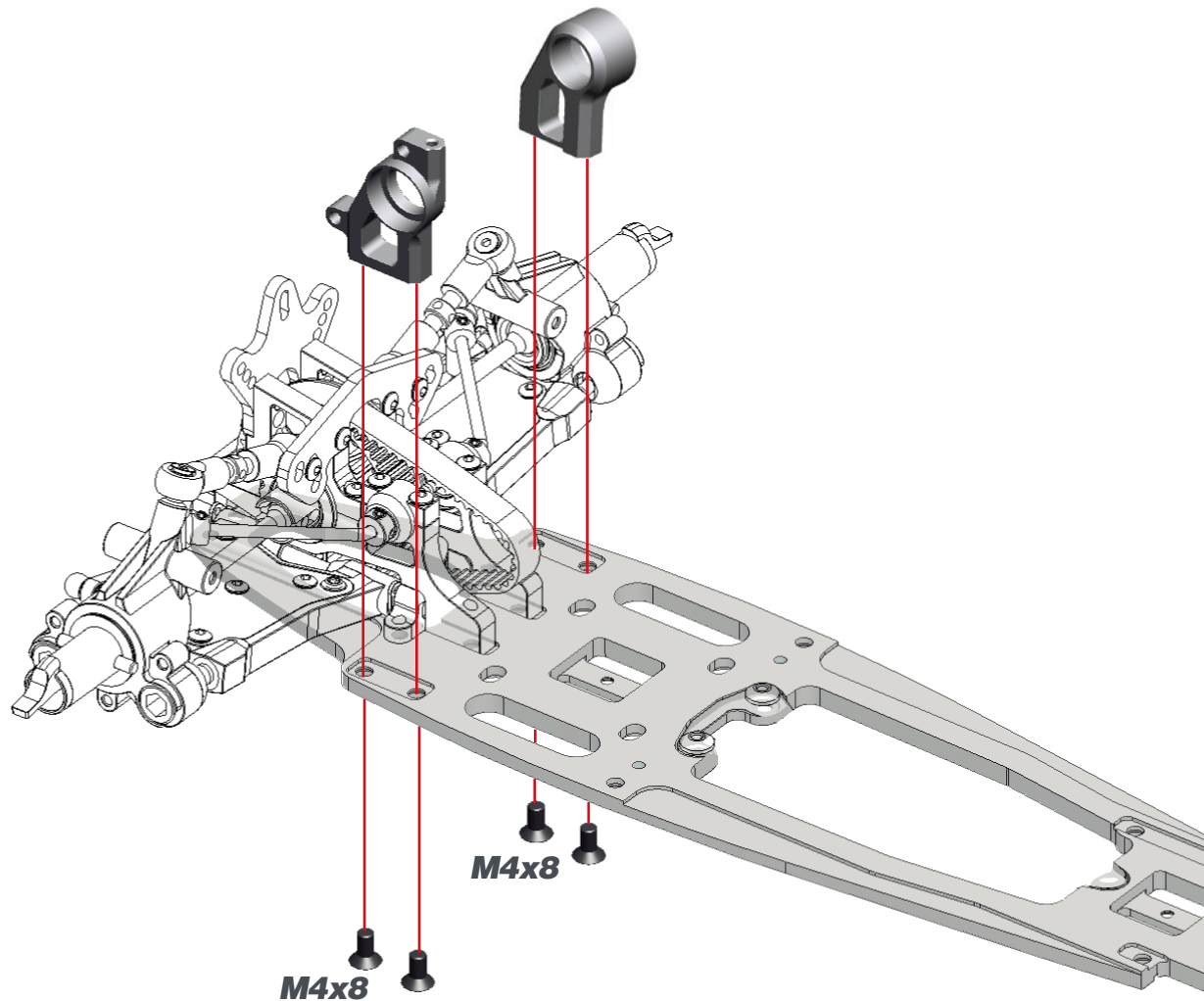

STEP 14

14.1

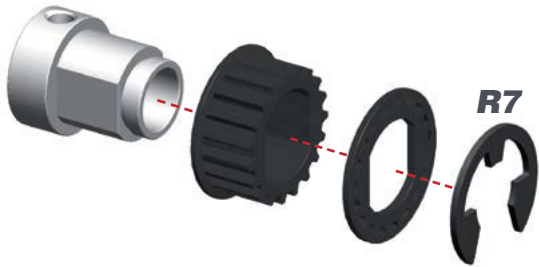

14.2



Adjust the position of the side pulley to have a little play on the 2-speed shaft.

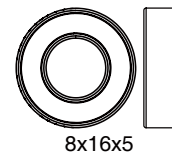
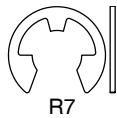
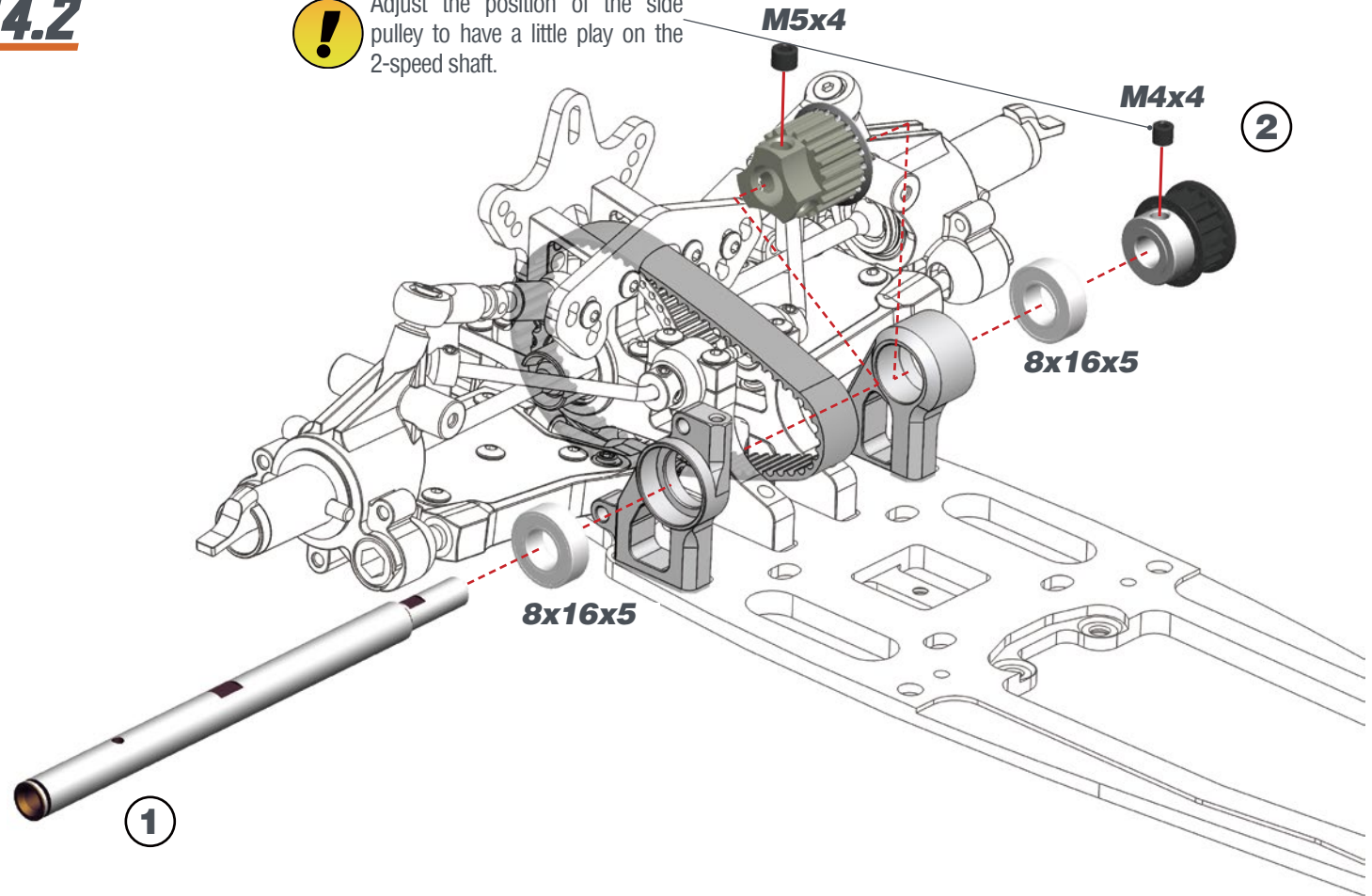

STEP 15 **BAG 5**

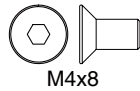
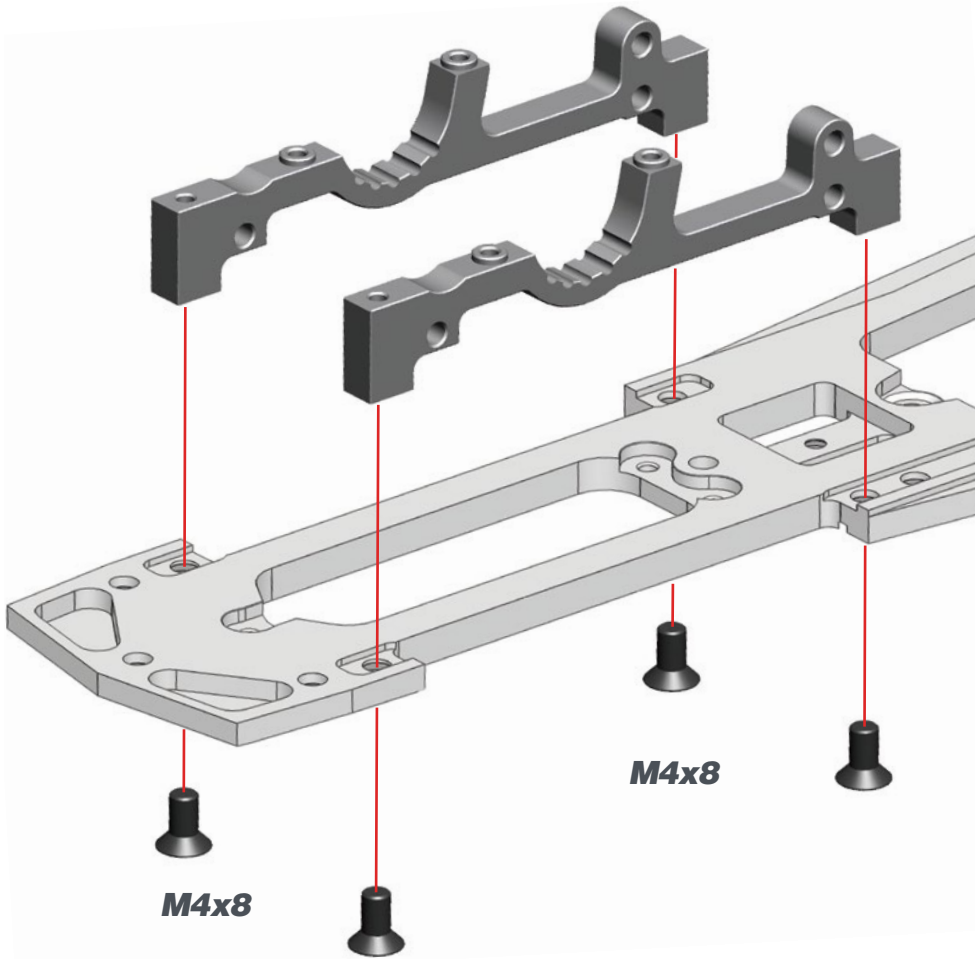

M4x8

STEP 16

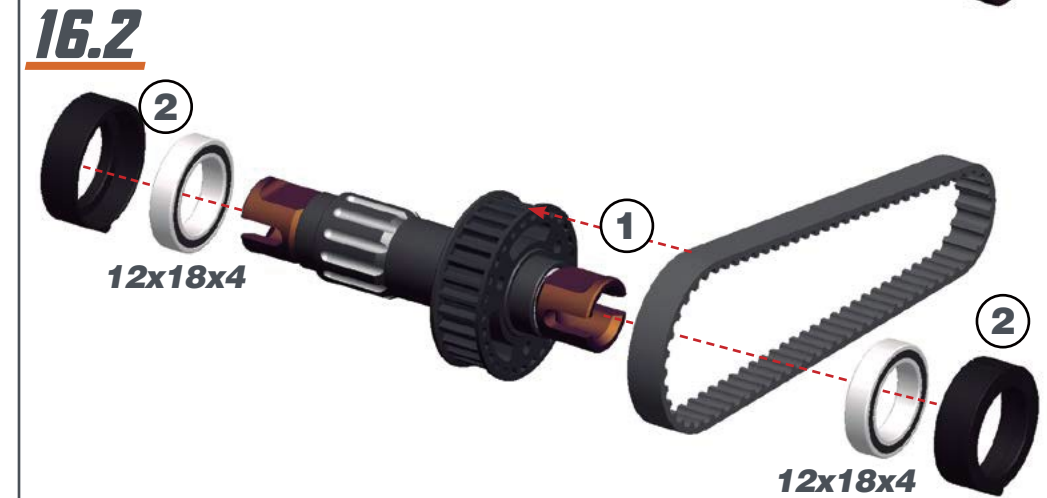
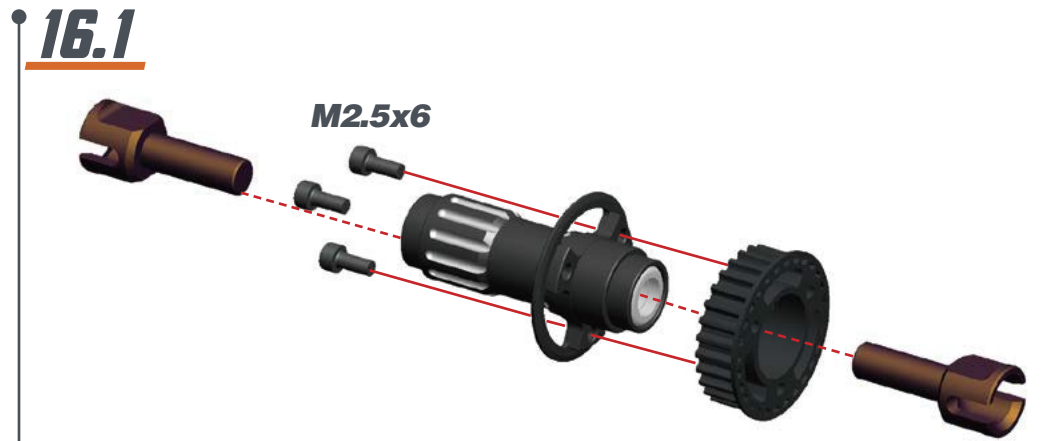

M2.5x6

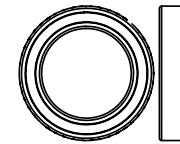

12x18x4

STEP 17

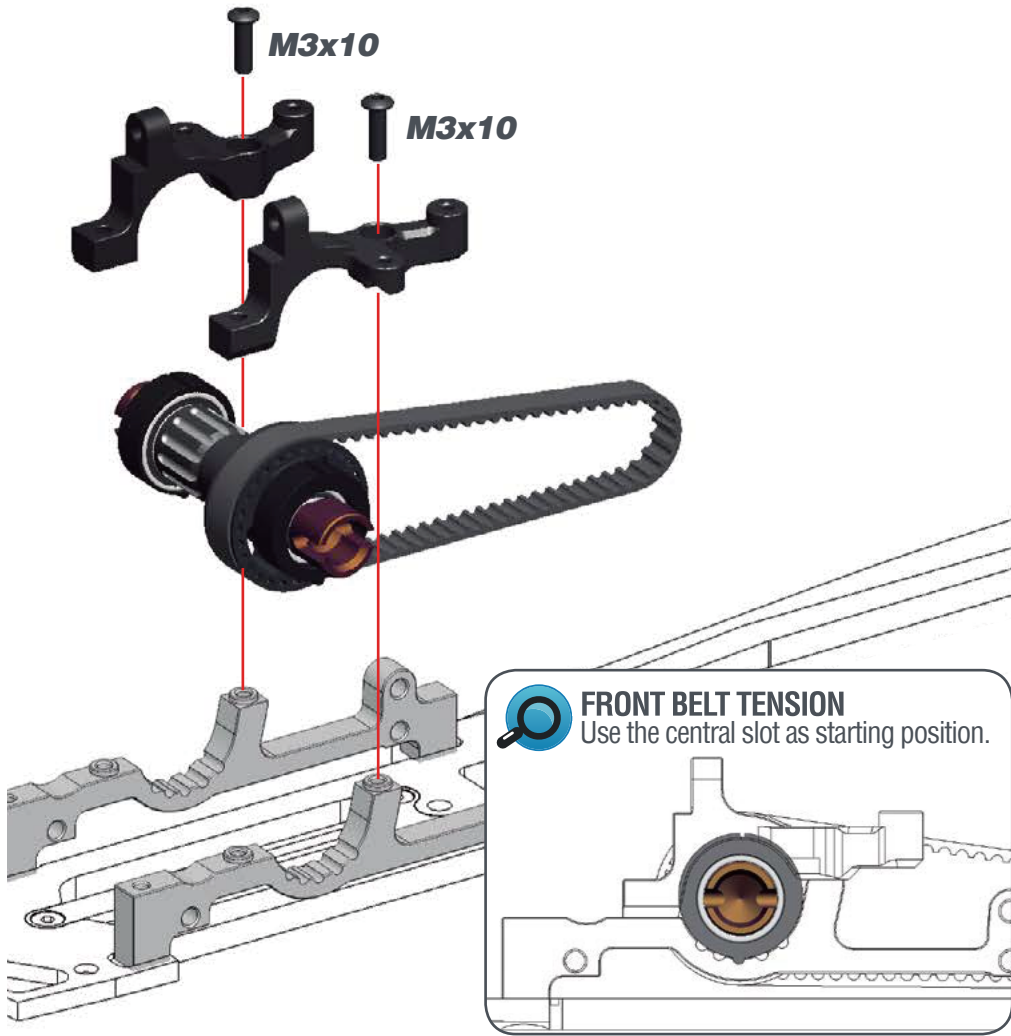

STEP 18

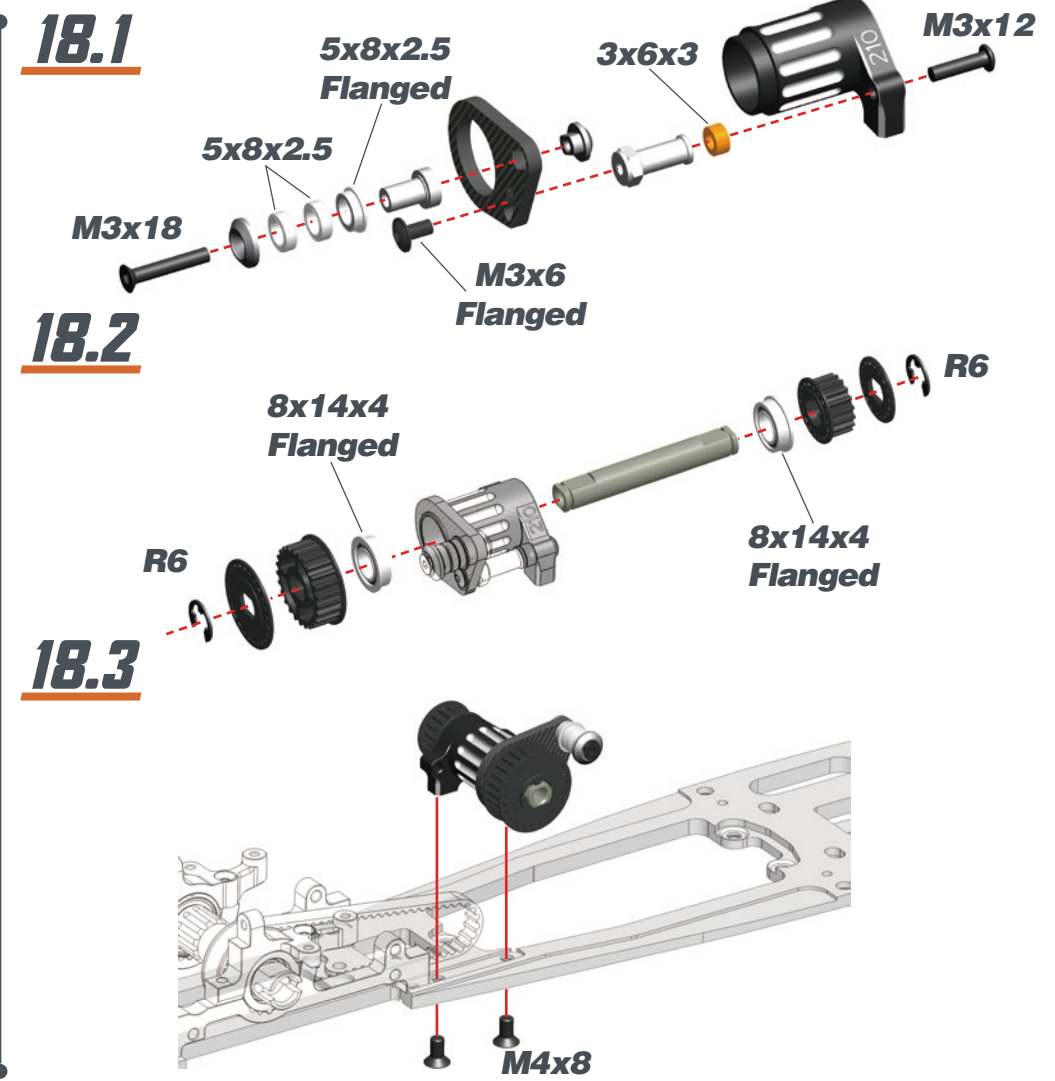

- M3x10
- 5x8x2.5 Flanged
- 5x8x2.5
- M3x12
- M3x6 Flanged
- M3x18
- 8x14x4 Flanged
- R6
- M4x8
- 3x6x3

STEP 19 BAG 6

19.1

L=R



19.3

L=R

Serpent 989 allows to move front bottom arms 3 mm in (NARROW) and out (WIDE). To maintain the same shock angle, use the suspension bracket and shock bracket as shown here.

NARROW

WIDE

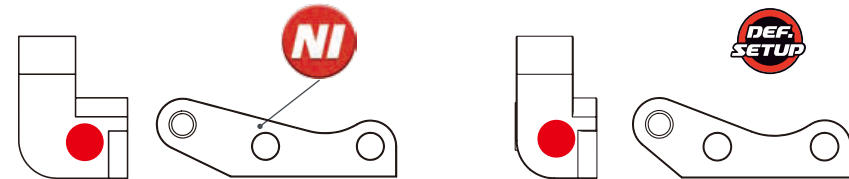

19.2

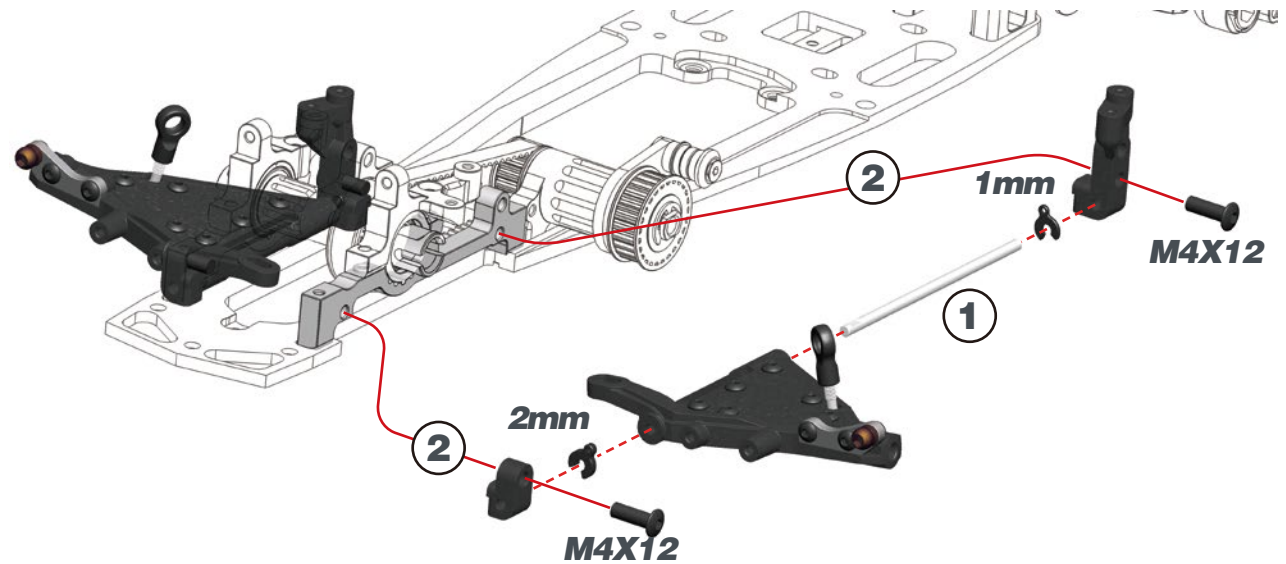
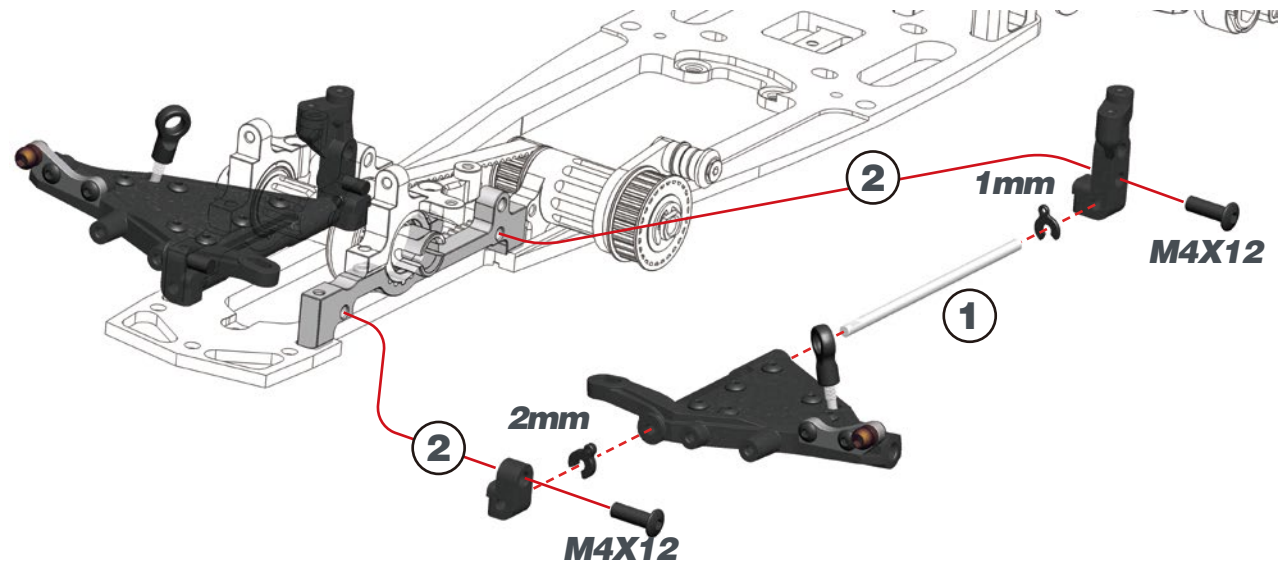

STEP 20

20.1



20.2



20.3

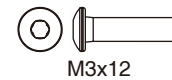
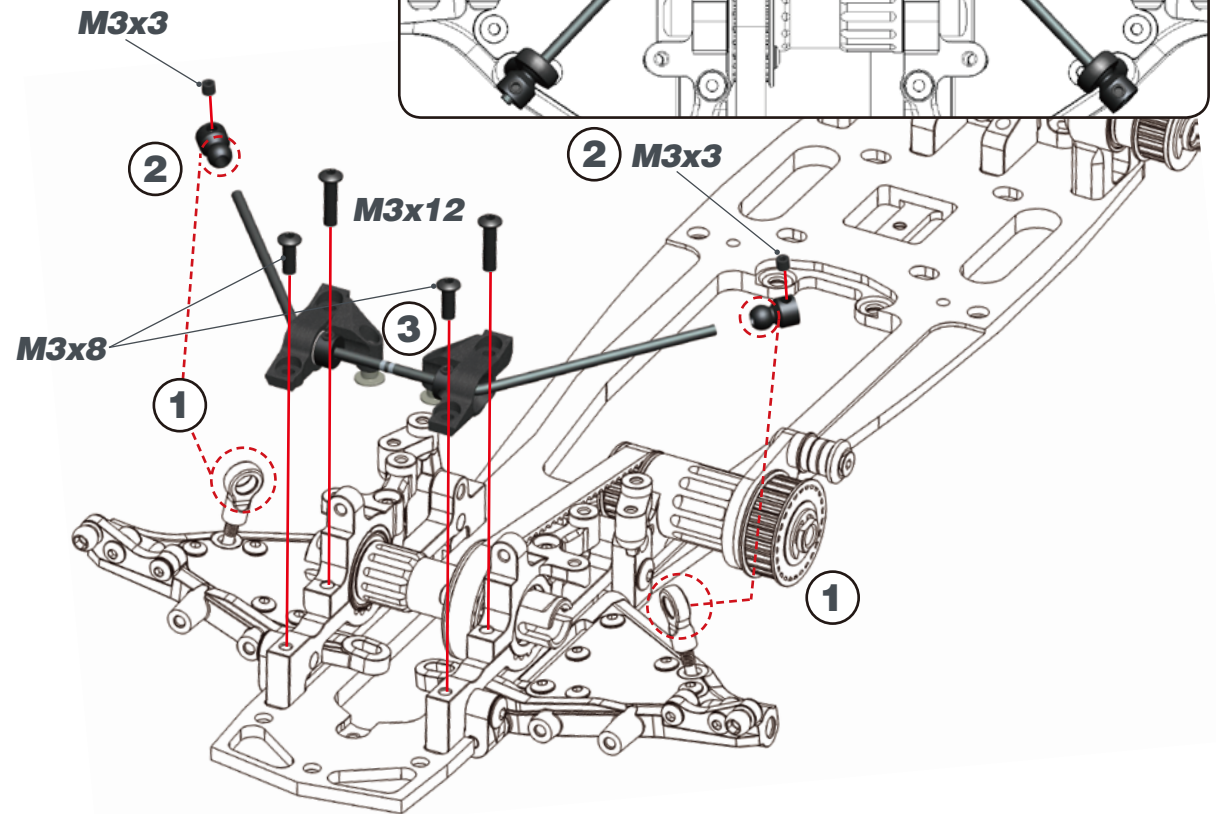
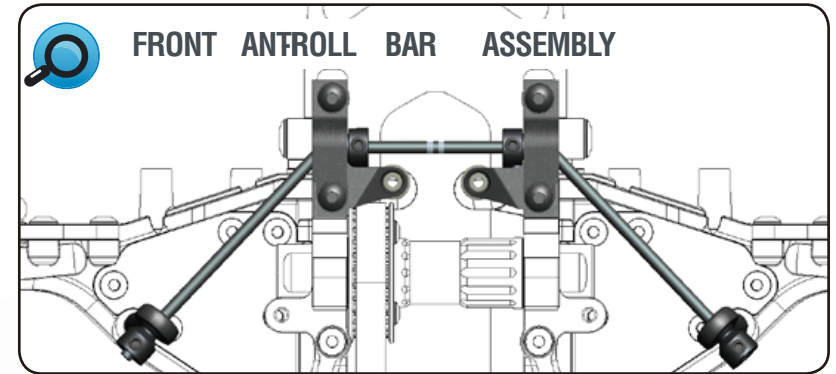

STEP 21 BAG 7

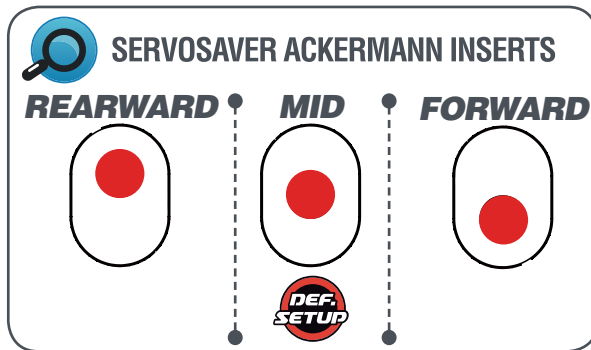

STEP 22

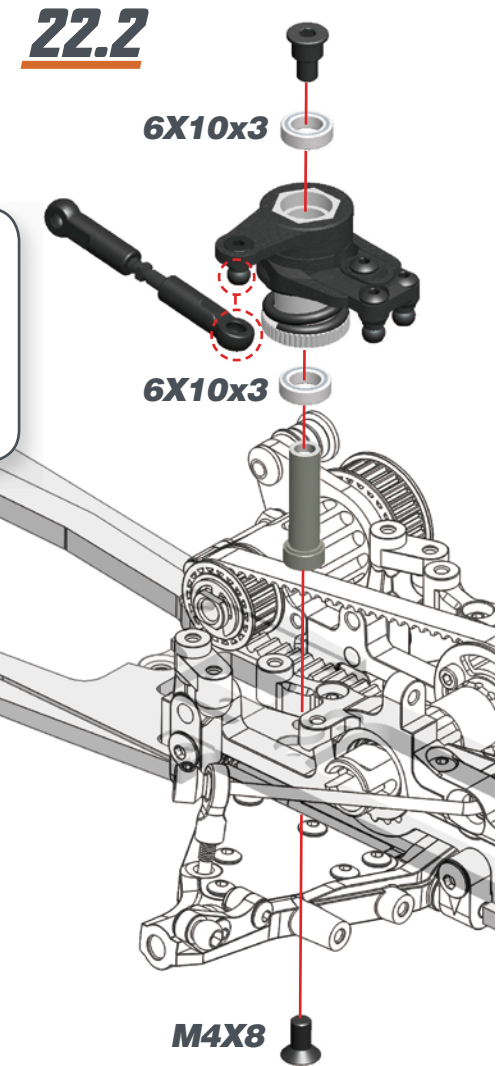

STEP 23

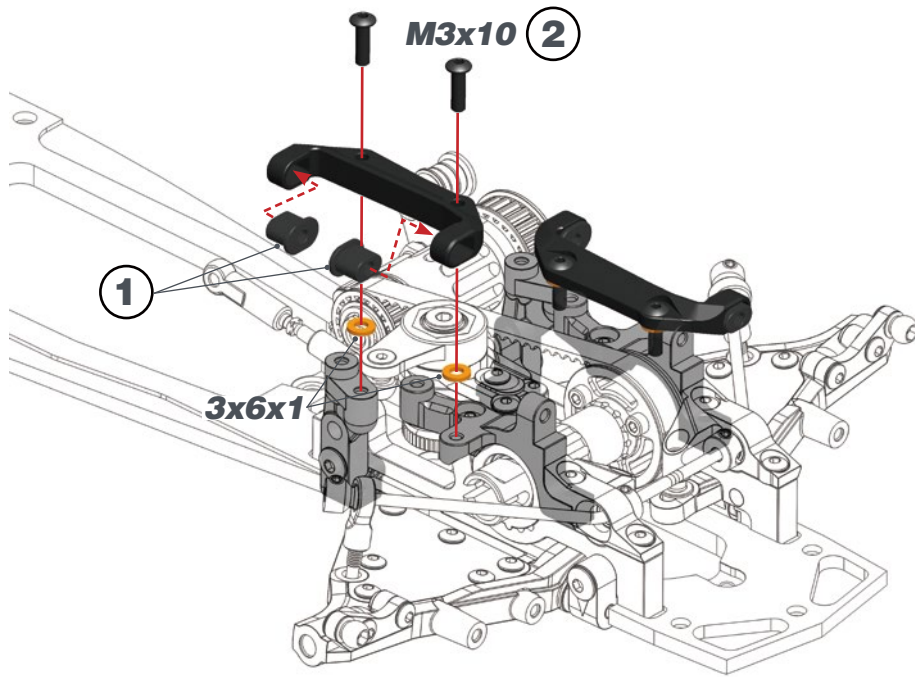

L=R FRONT SUSPENSION INSERTS CHART

INSIDE		MID		OUTSIDE	
RIGHT	LEFT	RIGHT	LEFT	RIGHT	LEFT

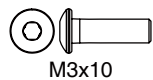

STEP 24

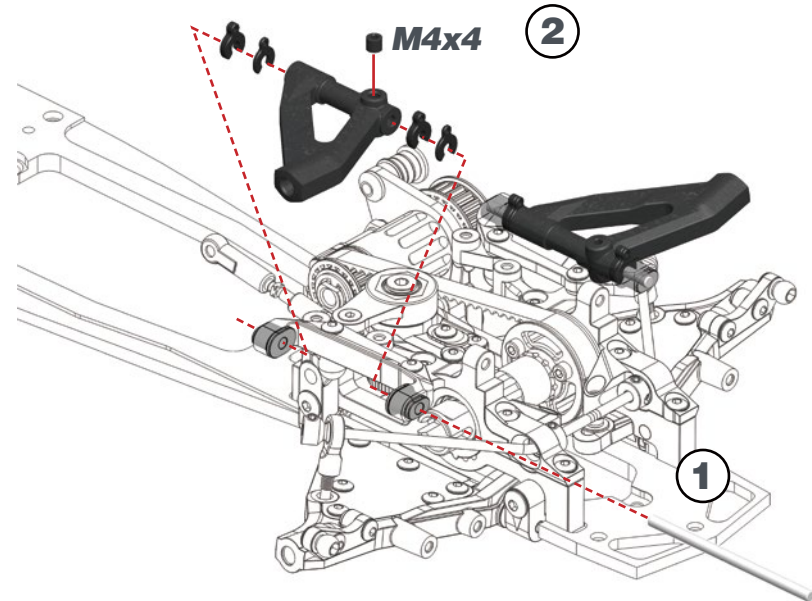

L=R FRONT CASTER DEFAULT SPACERS

2mm 2mm 1mm 1mm



STEP 25 BAG 8

25.1

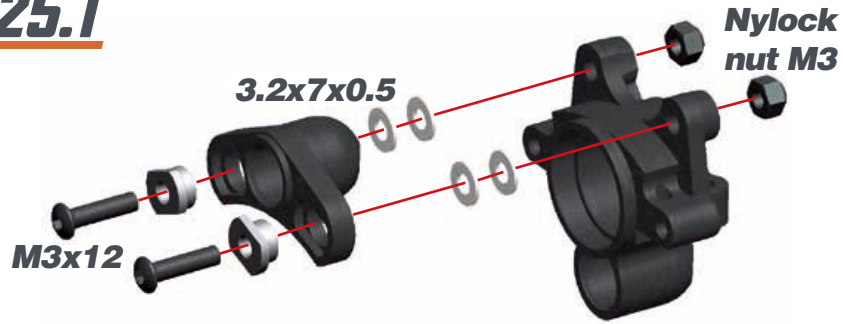

25.2

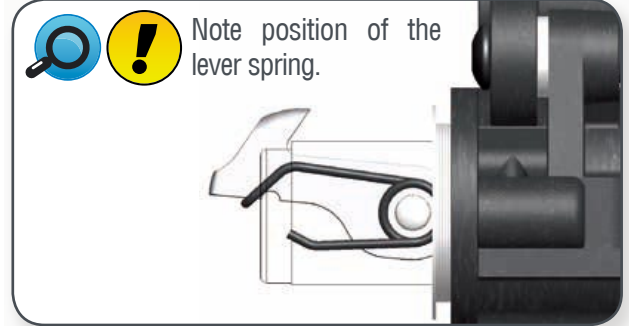
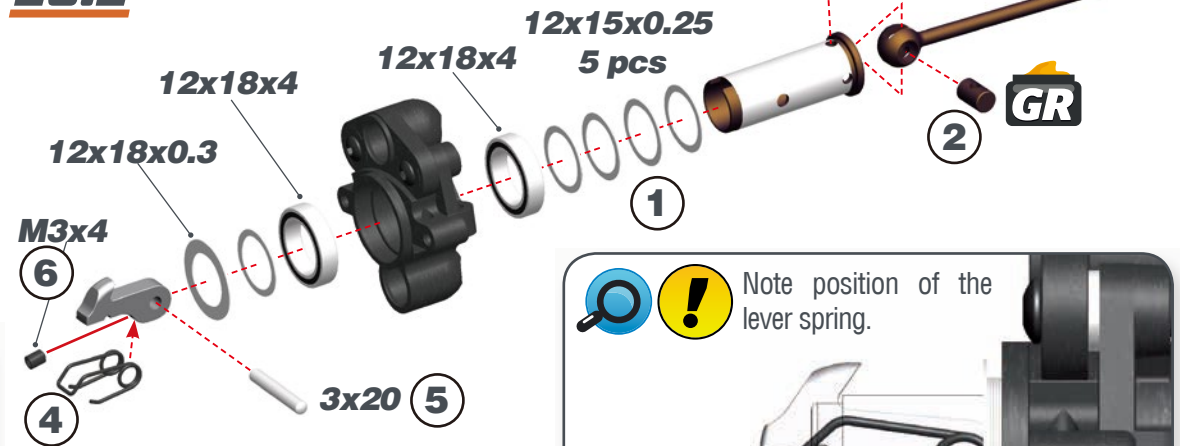

		STEERING BLOCK INSERTS CHART		
		LEADING	NEUTRAL DEF. SETUP	TRAILING
RIGHT				
LEFT				

25.3

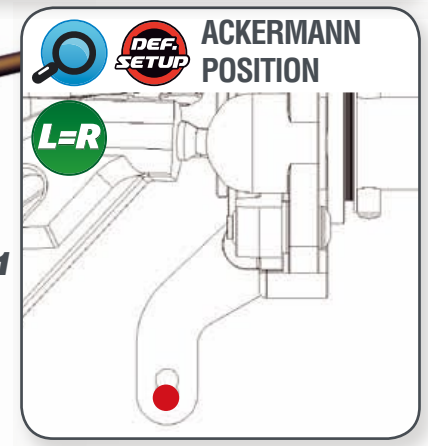
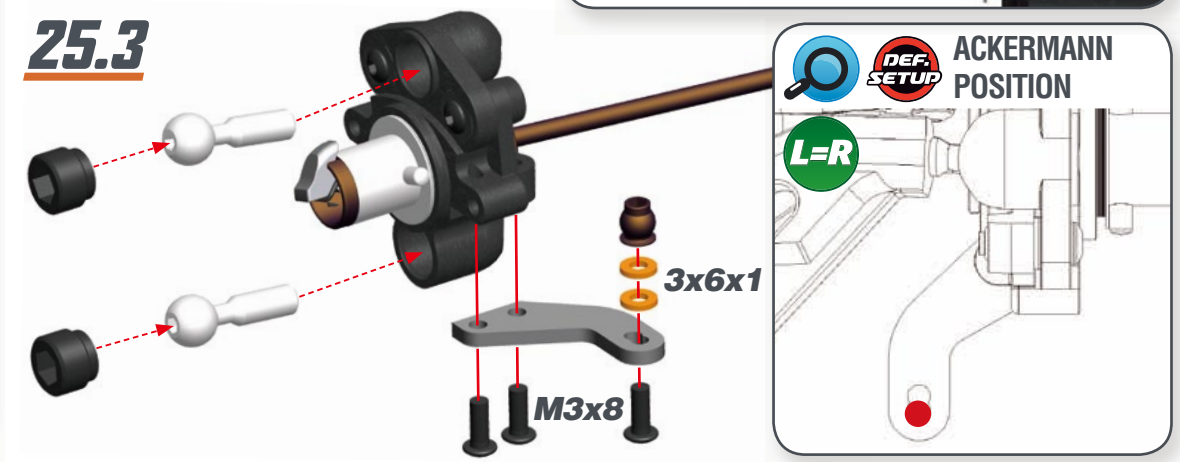

- M3x12
- 3.2x7x0.5
- Nylock Nut M3
- 12x18x1 Conical
- 12x15x0.25
- 12x18x4
- 3x20
- M3x4
- 2.5x12
- 3x6x1
- M3x6
- M3x8

STEP 26

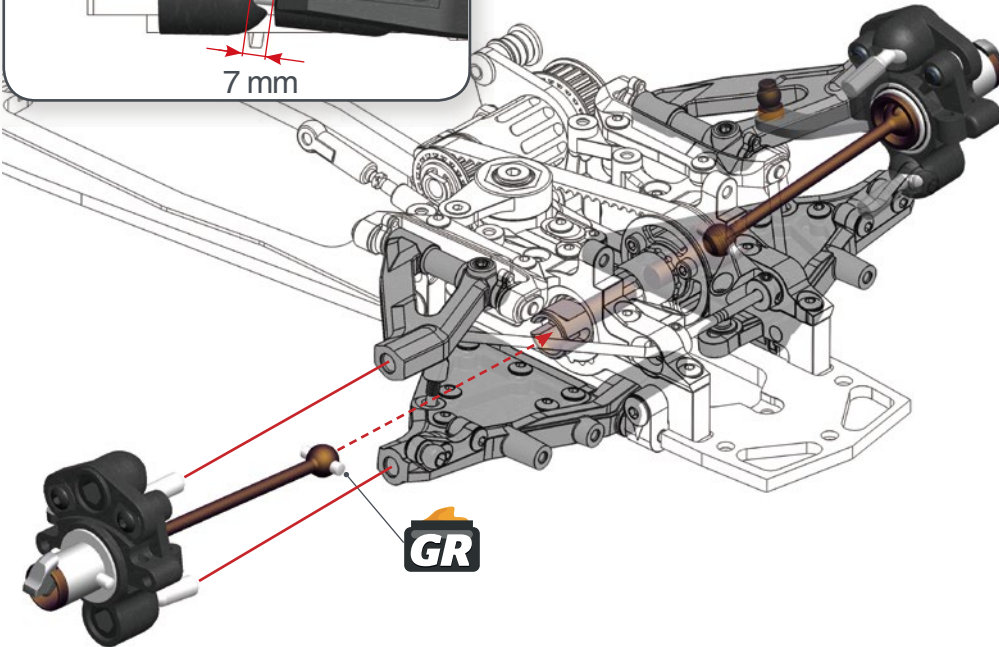
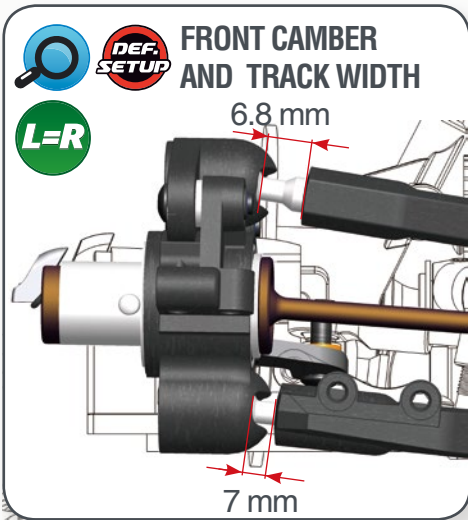

STEP 27

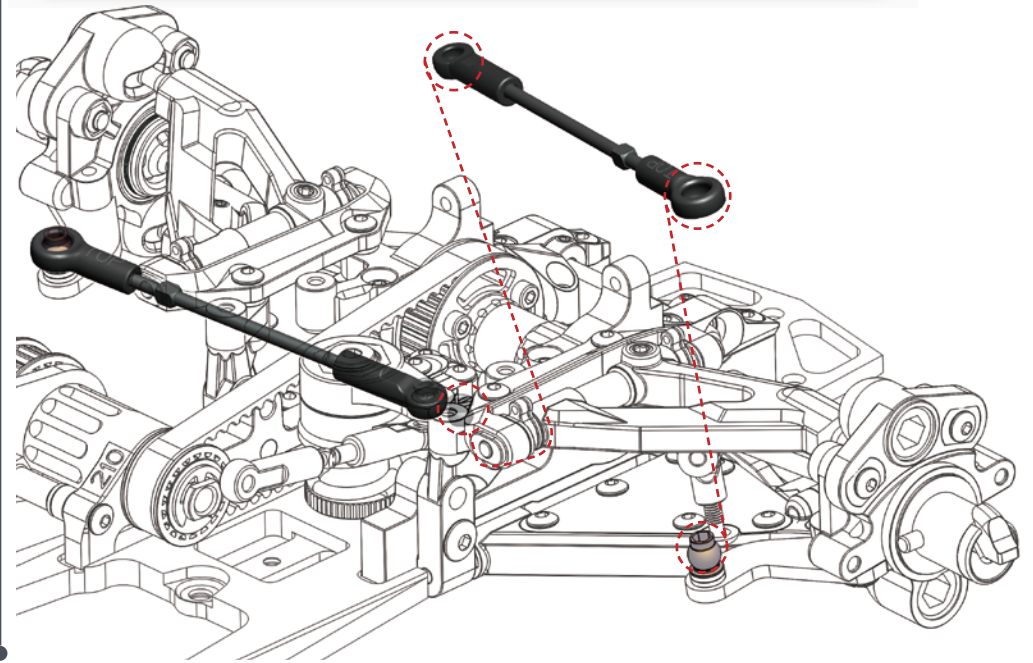
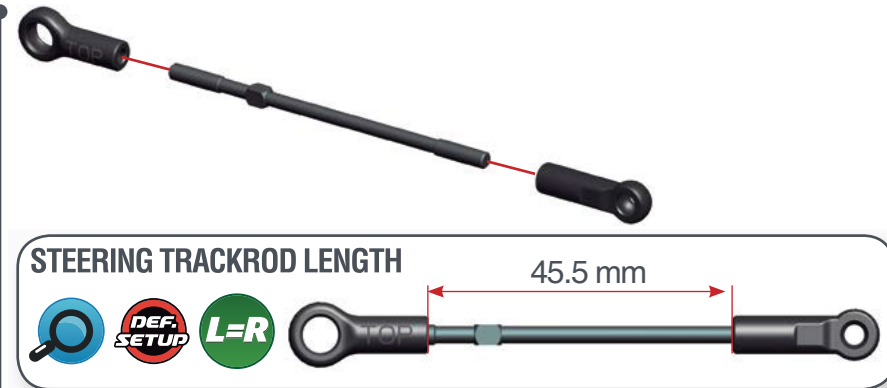

STEP 28 BAG 9

STEP 29

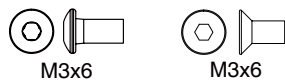
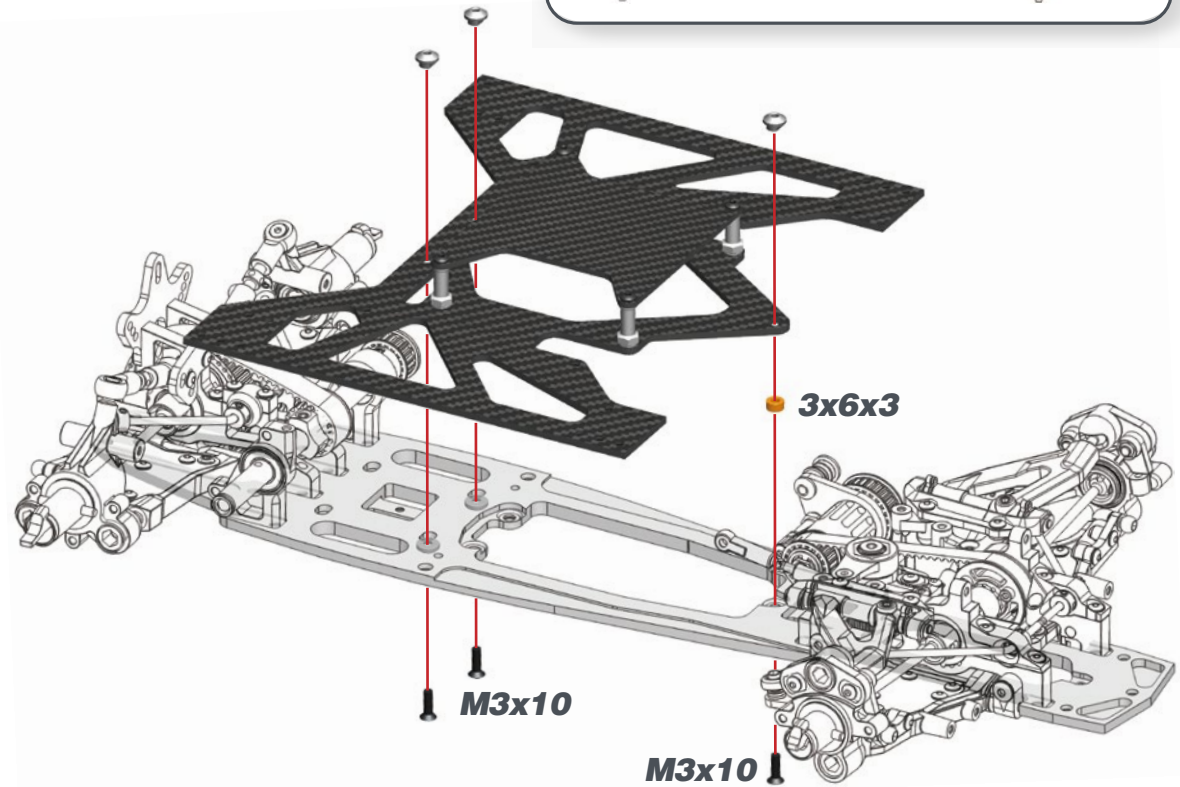
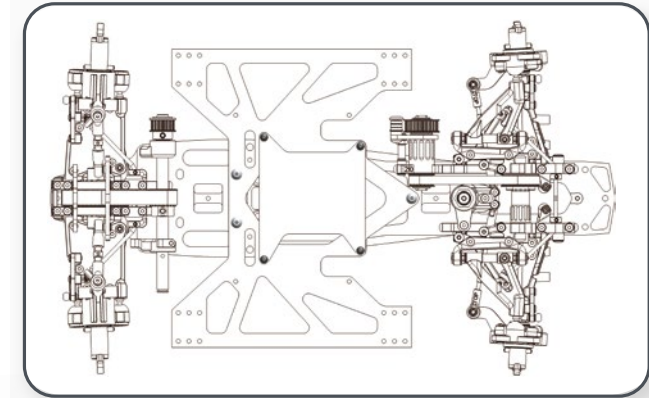
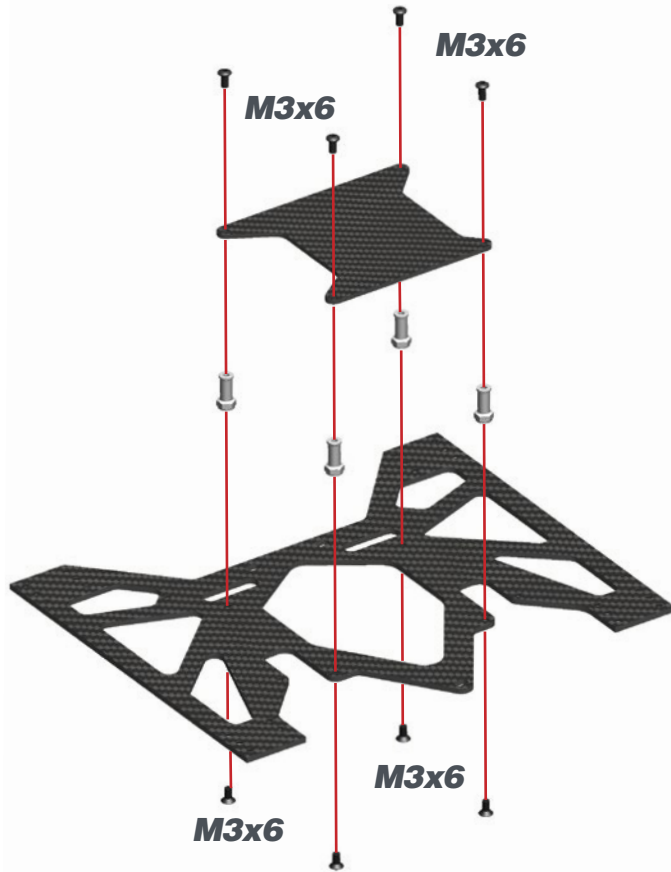

STEP 30

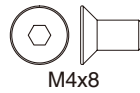
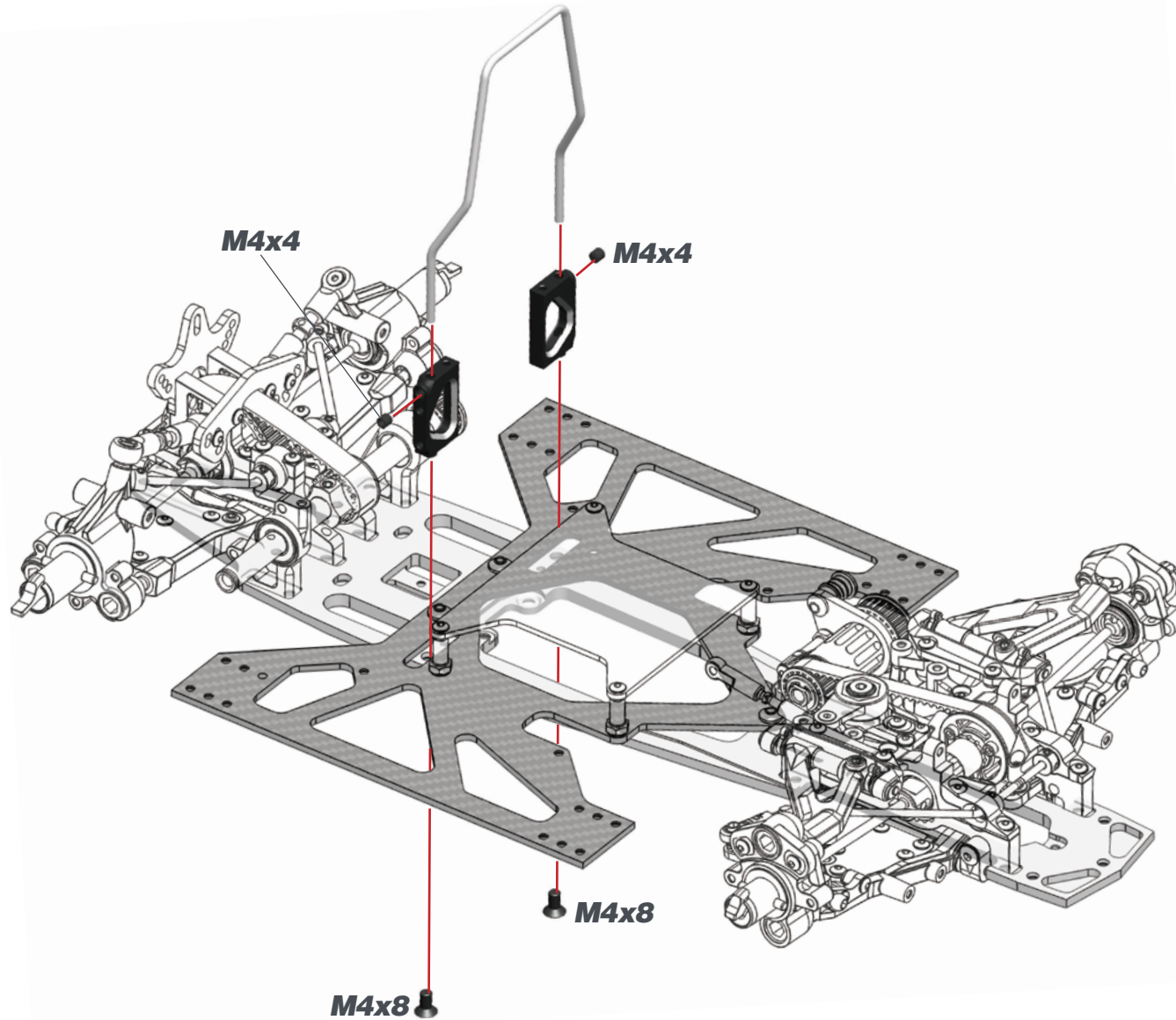

STEP 31

STEP 32

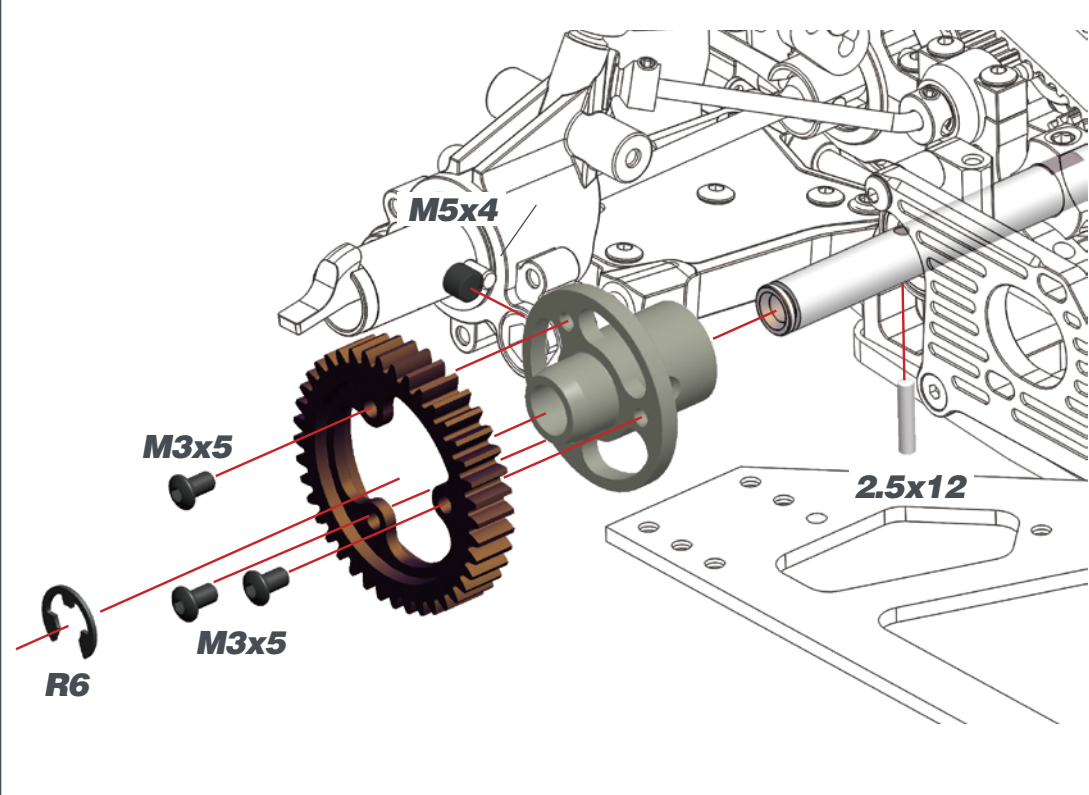
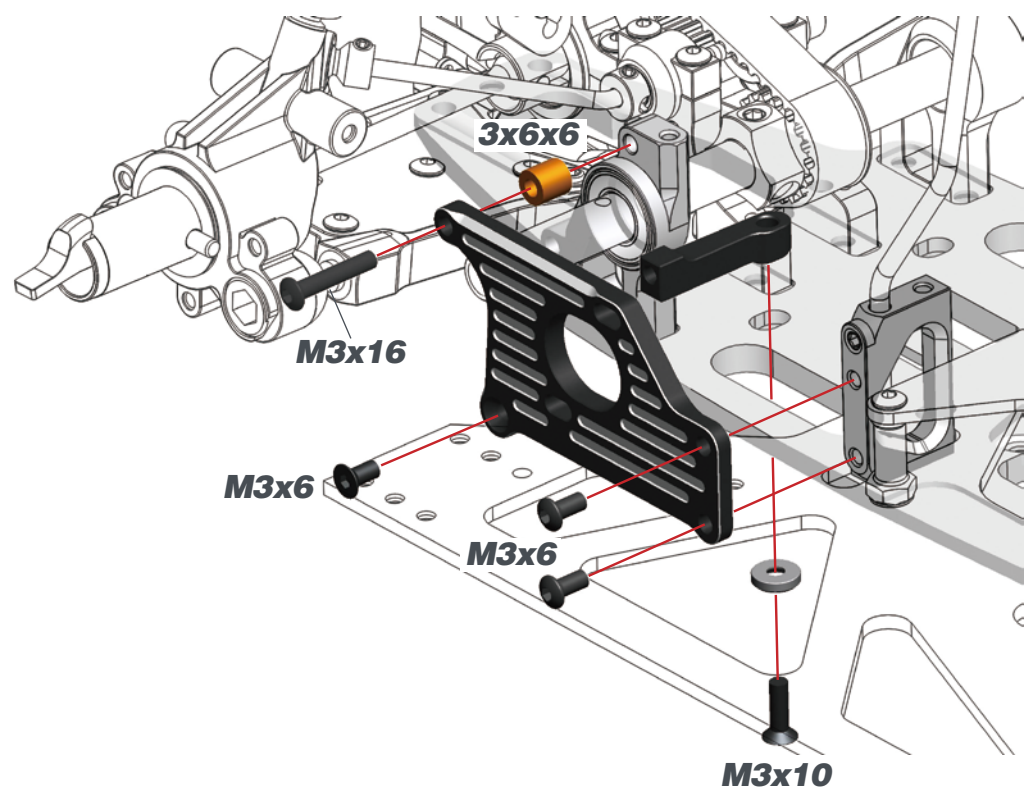

- M3x6
- M3x16
- M3x6
- M3x10
- 3x6x6

- R6
- M3x5
- M5x4
- 2.5x12

STEP 33

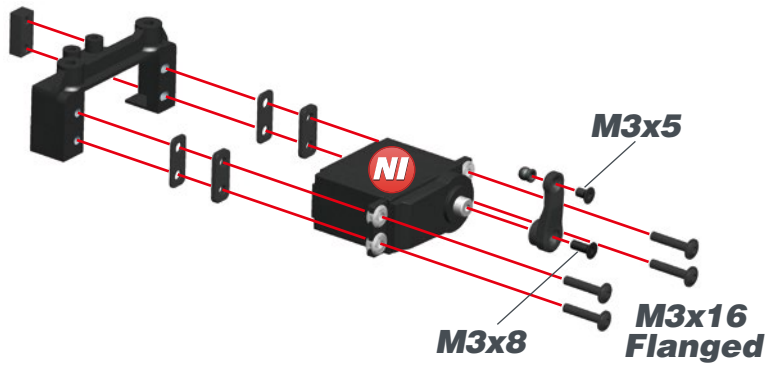

M3x5



M3x8



M3x16 Flanged

STEP 34

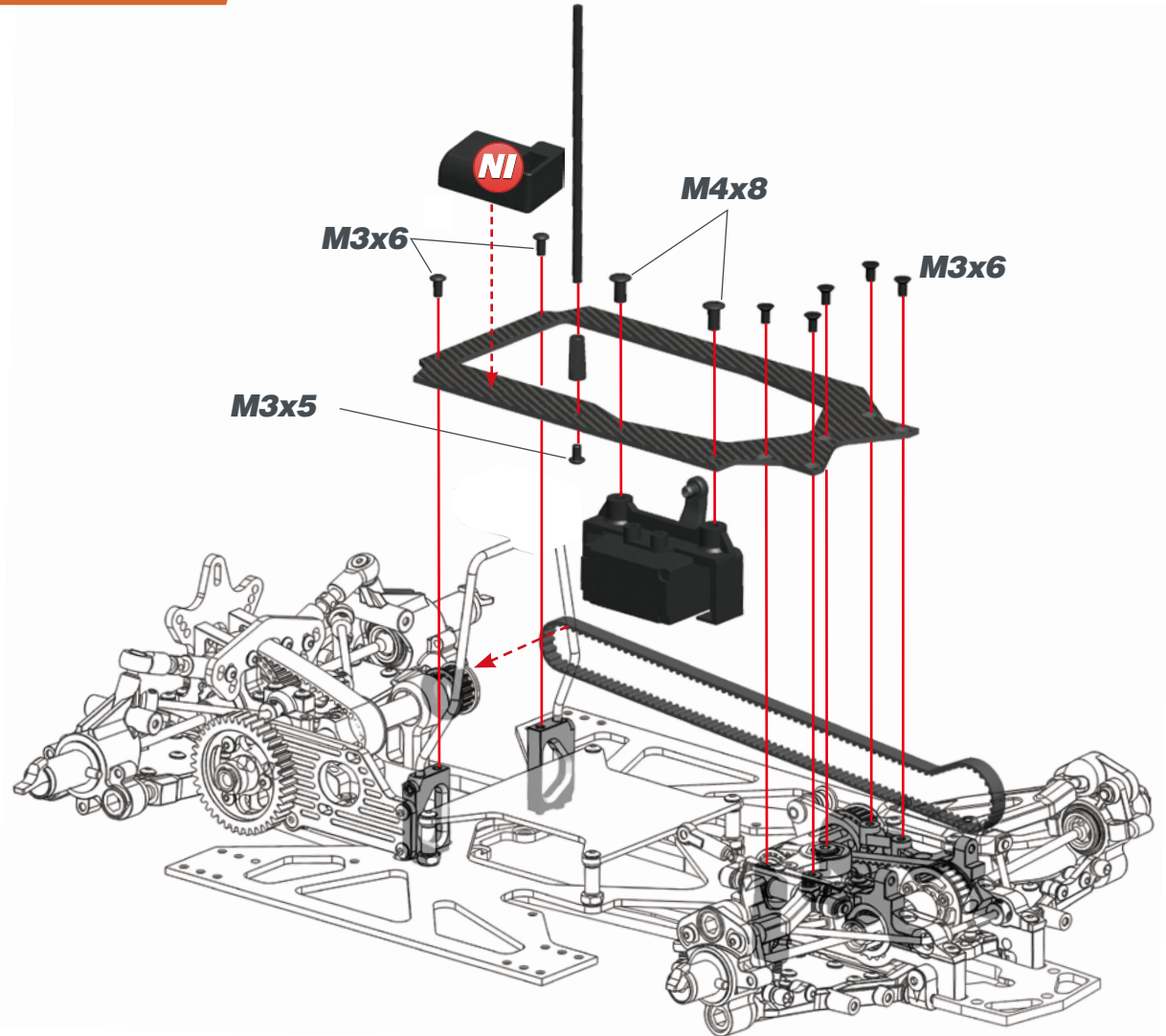

M3x6

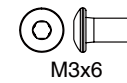

M3x6



M4x8

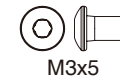

M3x5

STEP 35 SHOCKS BAG

35.1

Use some silicone oil during the assembly.

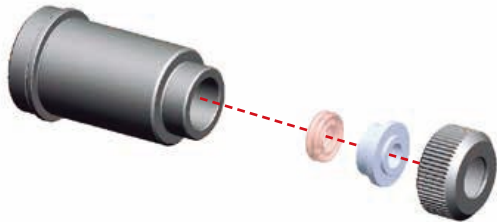

Note the correct orientation of the shock spacers.

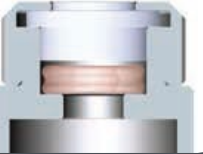

35.2

Insert the o-ring inside the spring collar.

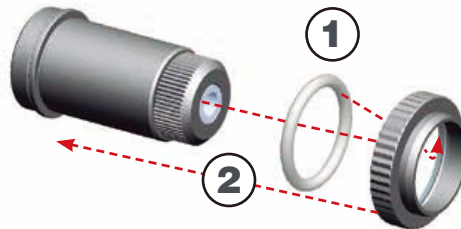

Note the correct position of the o-ring.



STEP 36

36.1



For the correct piston holes please check the default setupsheet.

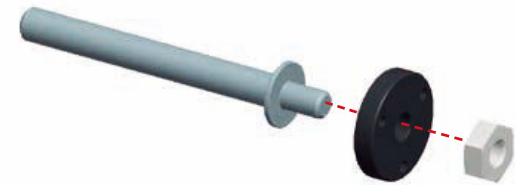

36.2



Use some silicone oil during the assembly.

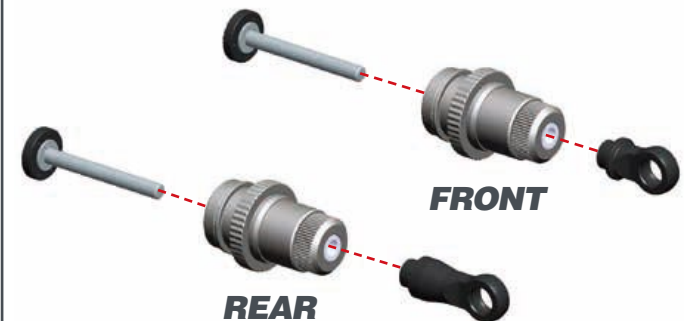

STEP 37

37.1

Push the shock top and the membrane into the shock cap.



37.2

1- Fill up with silicone oil fully using the silicone oil supplied in the kit. For the correct cst value please check the default setupsheet.

2- Extend the shockrod fully

3- Move the shockrod slowly up and down to let ALL air bubbles escape.

4- Close top only 3/4.



37.3

1-Bleed: push the shockrod all the way in slowly, to allow excessive oil to escape.

2- Close the shock cap completely.



SHOCKS LENGTH:

Measure the shock length fully extended.

REAR
13 mm

FRONT
14.5 mm

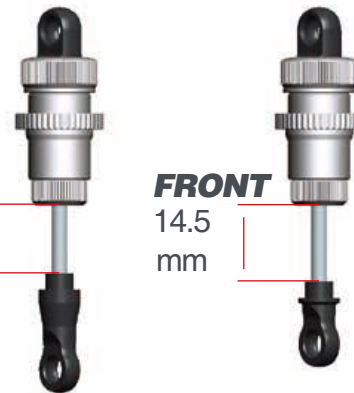

STEP 38

Assemble the spring and spring-cup (align correctly) to complete the shock.

FRONT

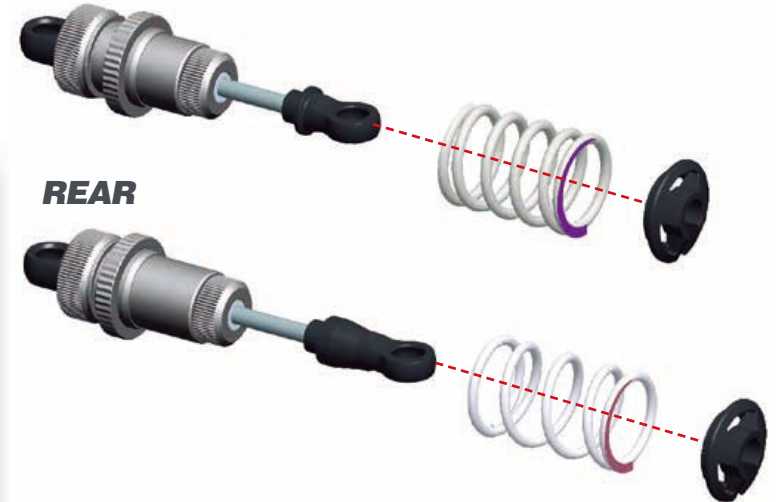

STEP 39 BAG 10

STEP 40

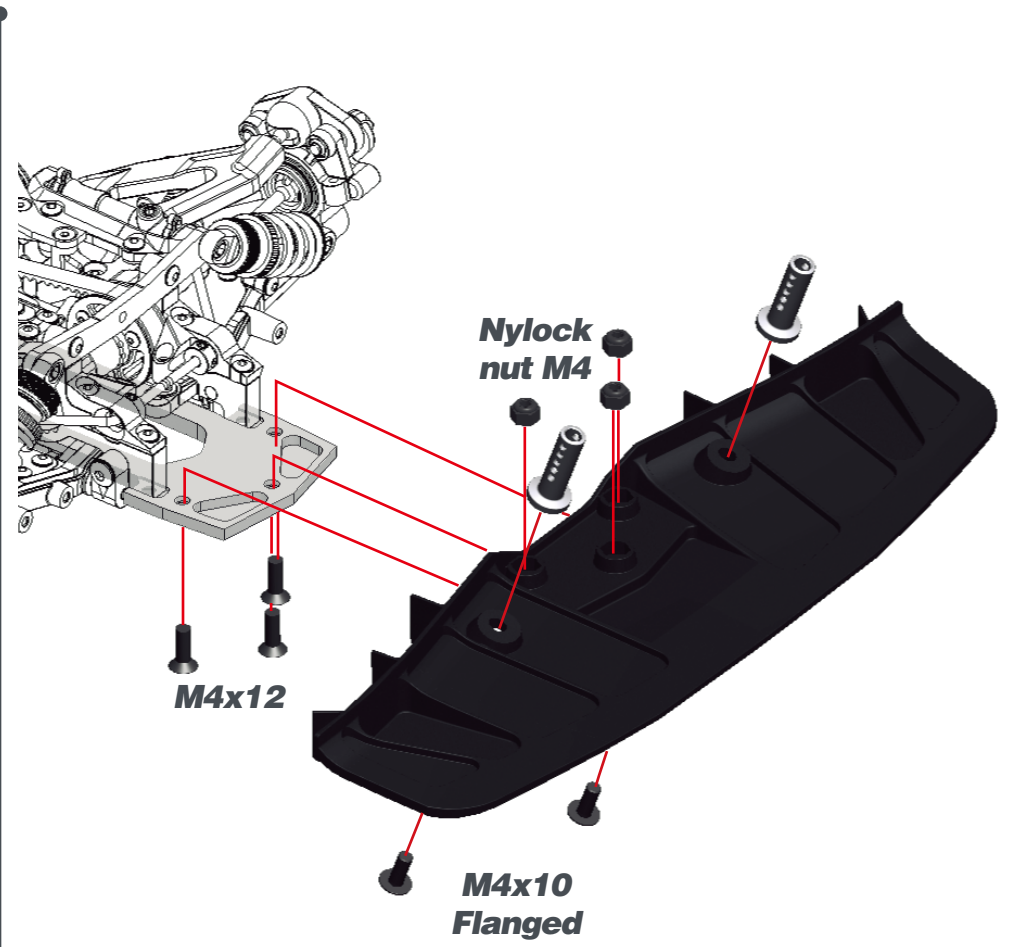
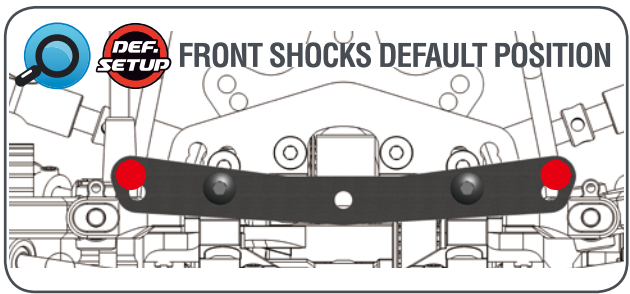
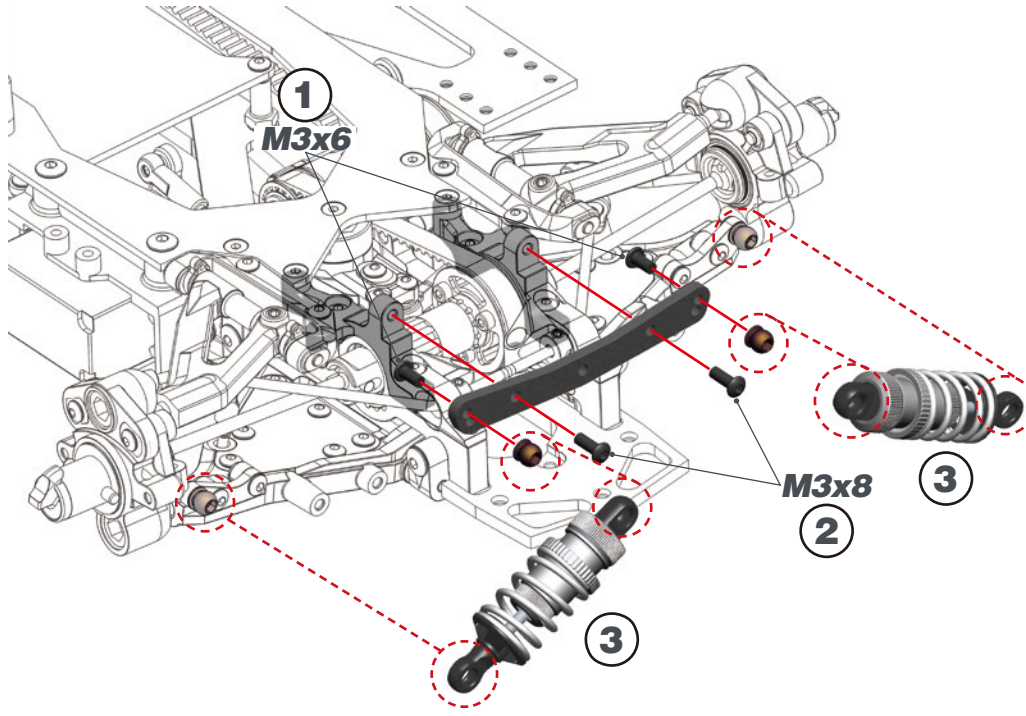

STEP 41

! Do not overtighten the M3x10 screws to prevent binding.

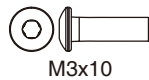
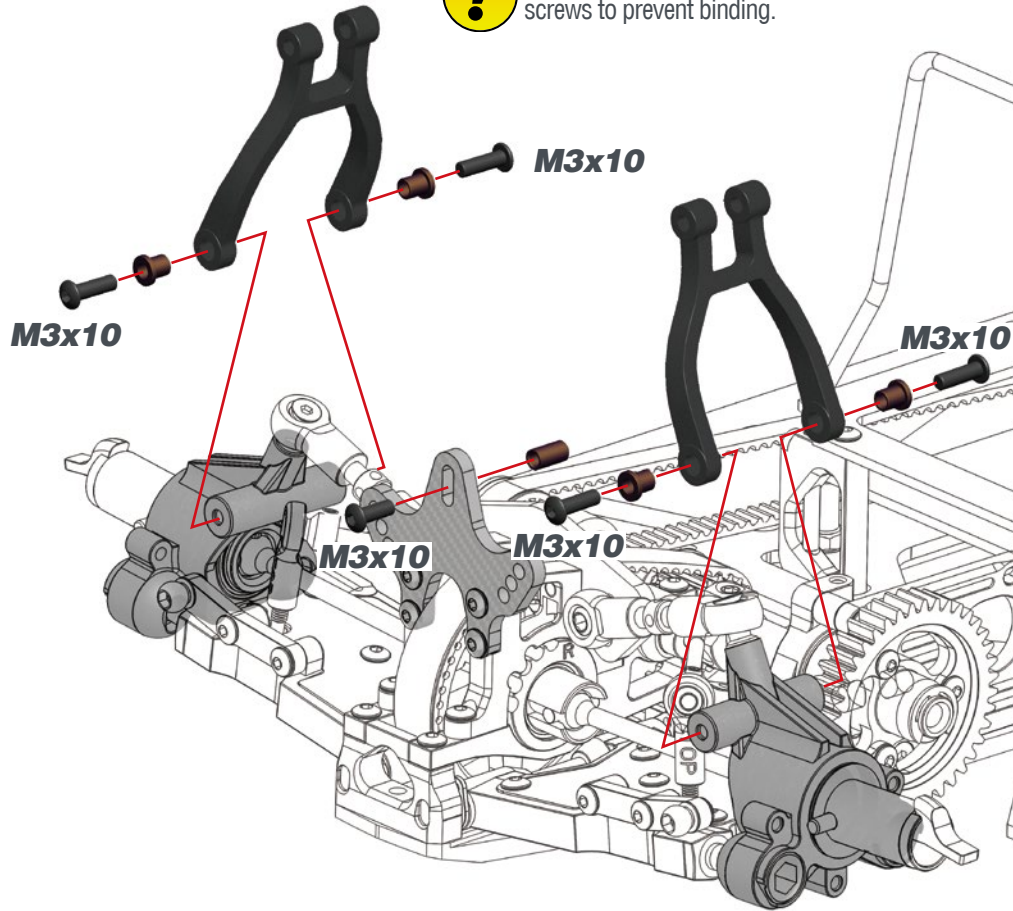

STEP 42

! Do not overtighten M3x6 Flanged screws.

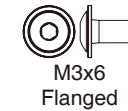
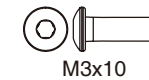
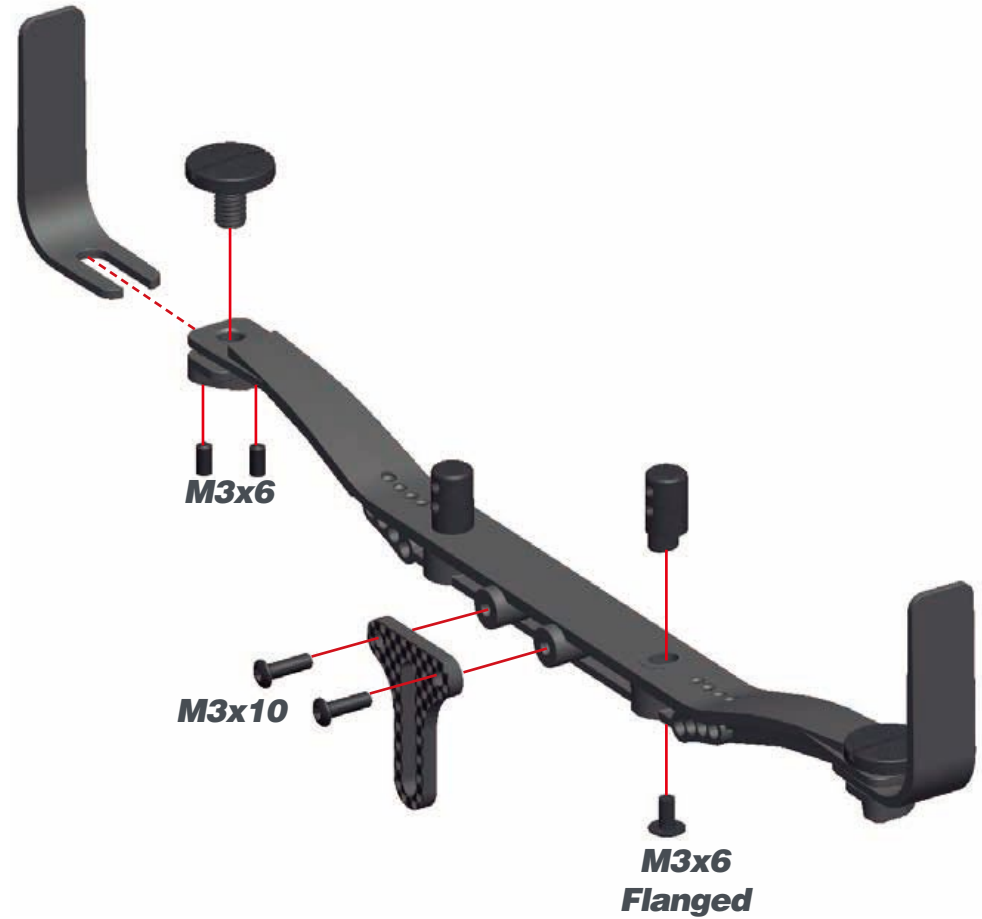

STEP 43

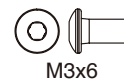
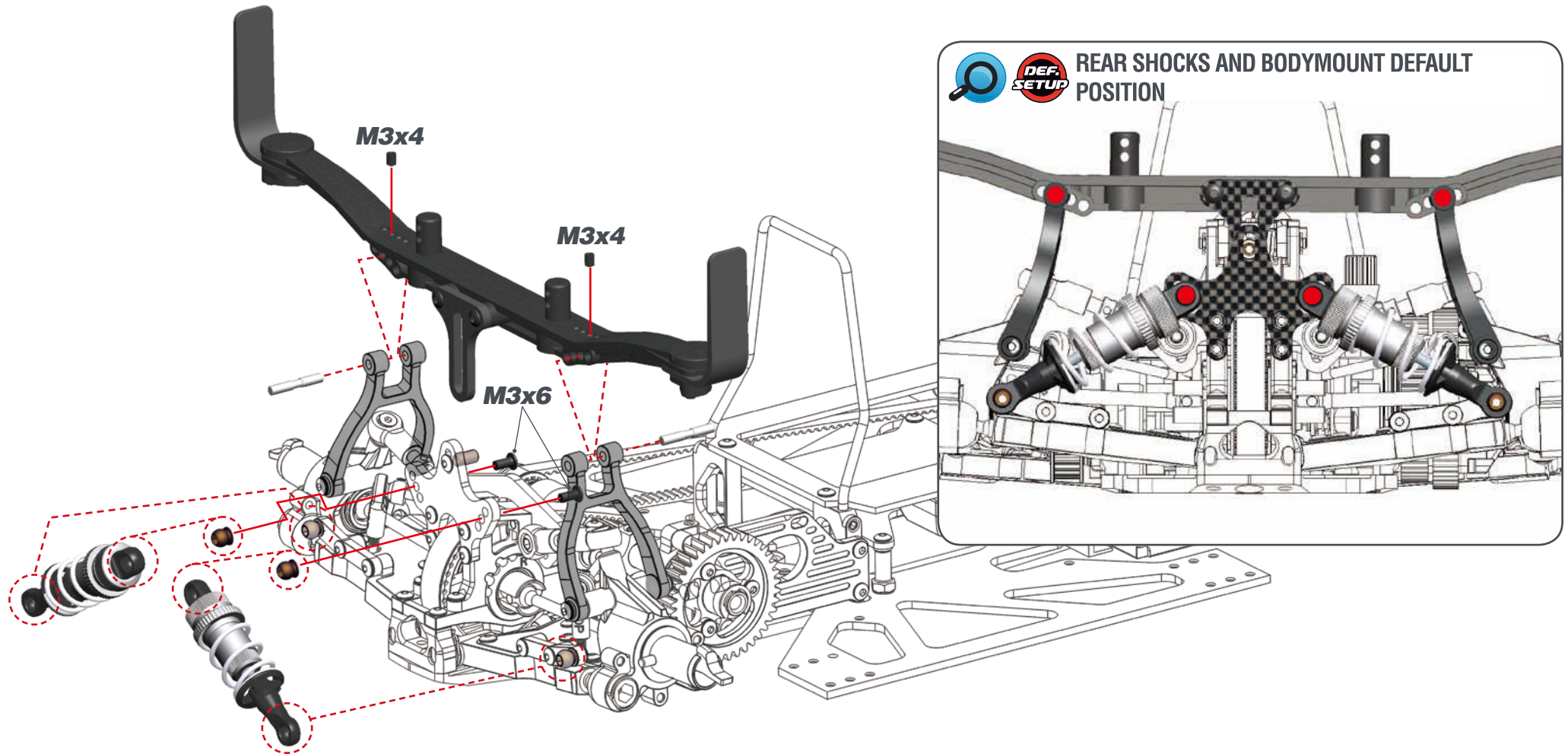

STEP 44

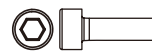
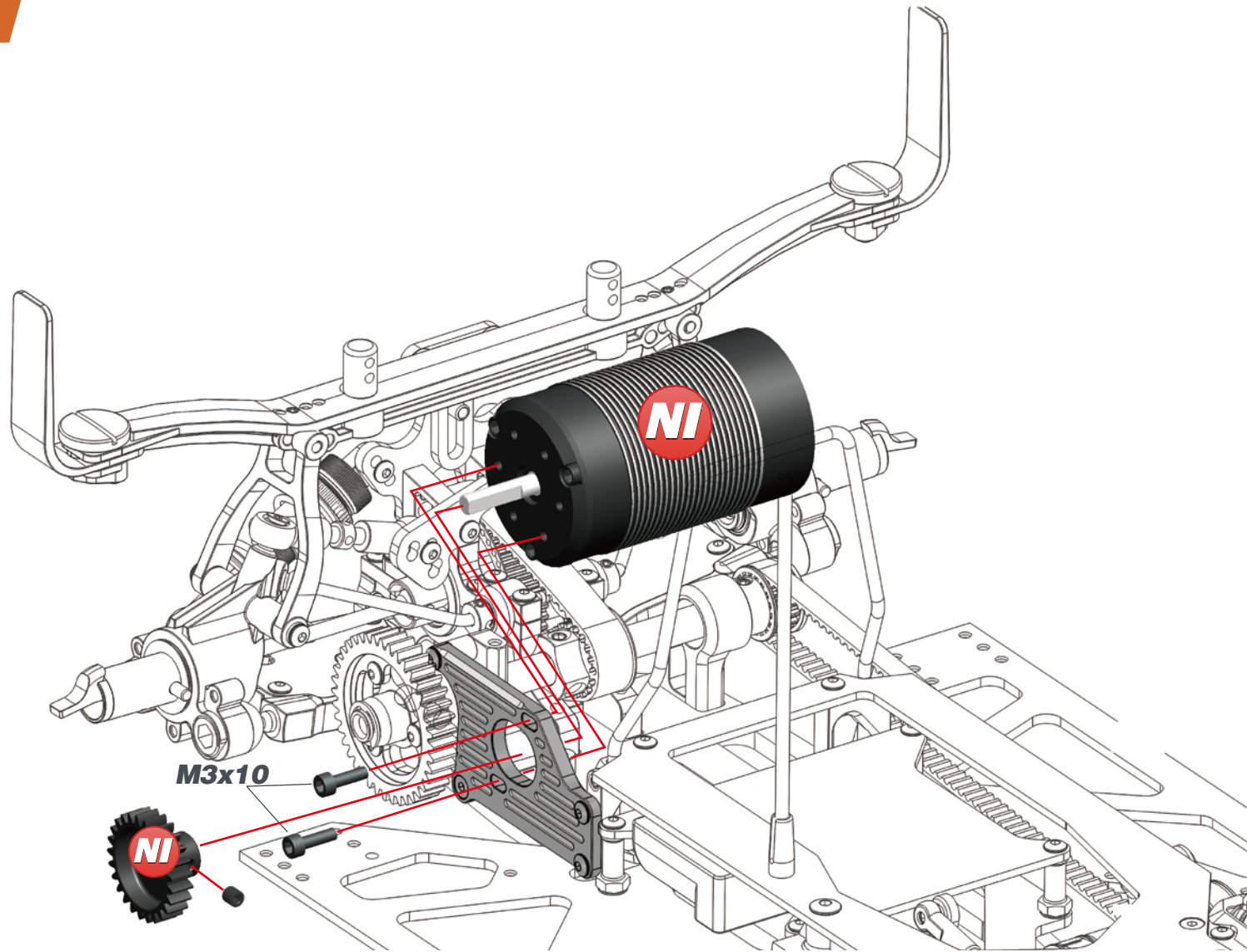

M3x10

STEP 45

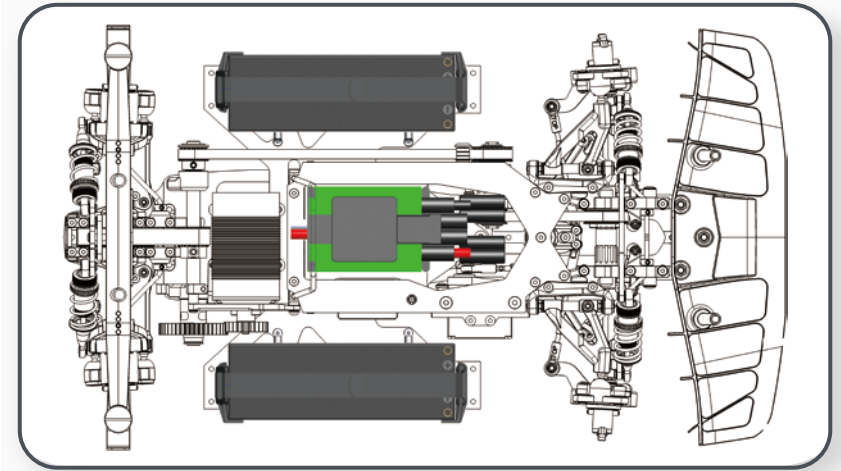
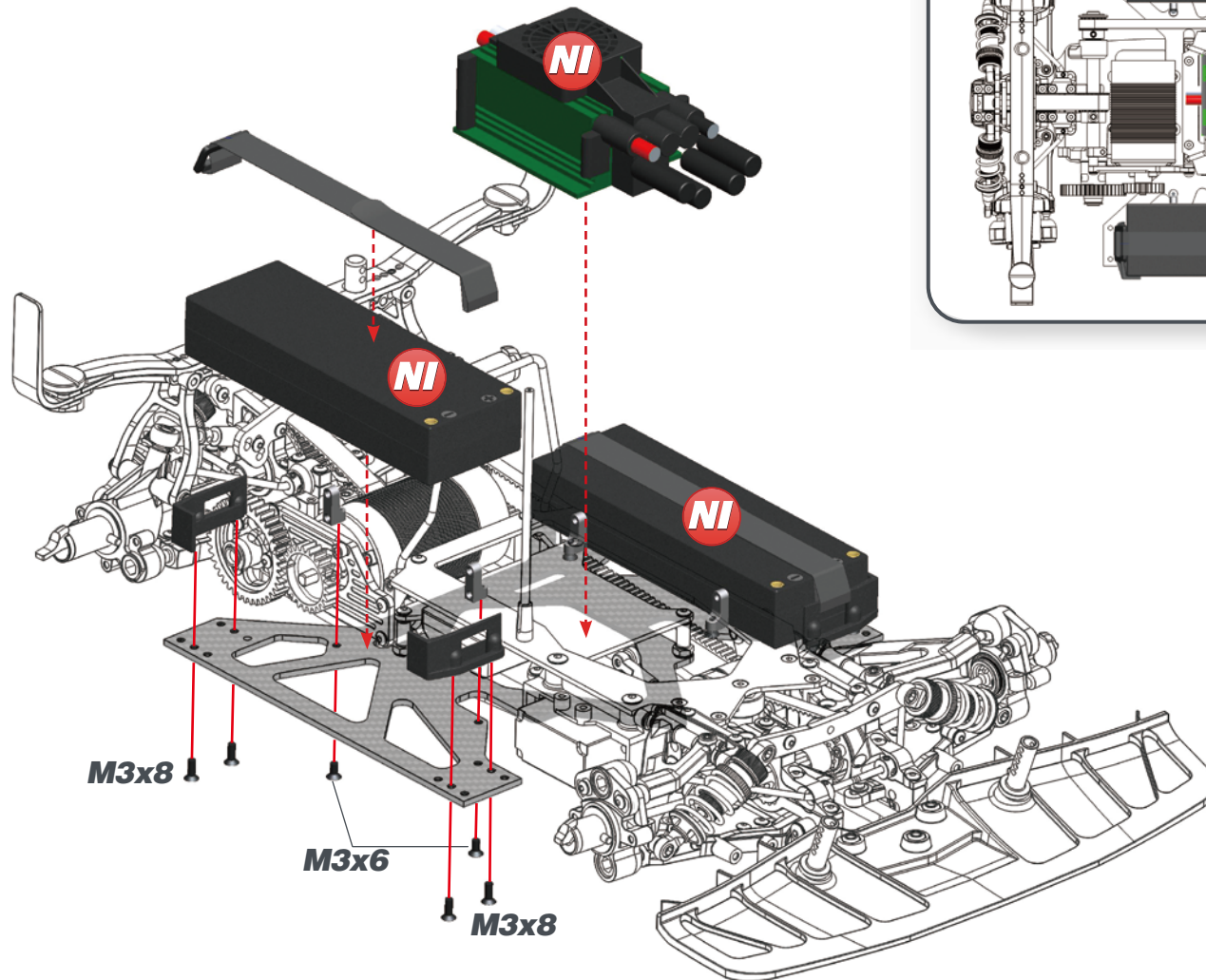

INDEX

SHOCKS EXPLODED VIEW	34
REAR EXPLODED VIEW	35
FRONT I EXPLODED VIEW	36
FRONT II EXPLODED VIEW	37
RADIO EXPLODEDE VIEW	38
BUMPER AND BODYMOUNT EXPLODED VIEW	39
FINAL EXPLODED VIEW	40
TEAM SERPENT NETWORK	41

903741 Shockset XLV short (2)



- 160147 Shock onroad big bore bushing LF (4)
- 160300 Spring white L23 (2.3/13) (2)
- 160301 Spring yellow L23 (2.8/16) (2)
- 160302 Spring orange L23 (3.4/19.5) (2)
- 160303 Spring red L23 (4.1/23.5) (2)
- 160304 Spring pink L23 (4.0/28) (2)
- 160305 Spring blue L23 (5.8/33) (2)
- 160307 Spring green L23 (8/45.5) (2)
- 160308 Spring grey L23 (9/51.5) (2)
- 160309 Spring black L23 (10/57) (2)

- 160310 Spring-set short (5x2)
- 160311 Spring silver L21 (7.5/42.6) (2)
- 160320 Spring white L27 (2.3/13) (2)
- 160321 Spring yellow L27 (2.8/16) (2)
- 160322 Spring orange L27 (3.4/19.5) (2)
- 160323 Spring red L27 (4.1/23.5) (2)
- 160325 Spring blue L27 (5.8/33) (2)
- 160326 Spring purple L27 (6.8/39) (2)
- 160327 Spring green L27 (8/45.5) (2)
- 160328 Spring grey L27 (9/51.5) (2)

- 160329 Spring black L27 (10/57) (2)
- 160330 Spring-set L27 (5x2)
- 903777 Shock piston XLV 1 hole (4)
- 903778 Shock piston XLV 2 hole (4)
- 903779 Shock piston XLV 3 hole (4)
- 903780 Heave demper set rear
- 903781 Heave demper set front
- 903788 Shockbody XLV short NiCoated (2)



REAR EXPLODED VIEW

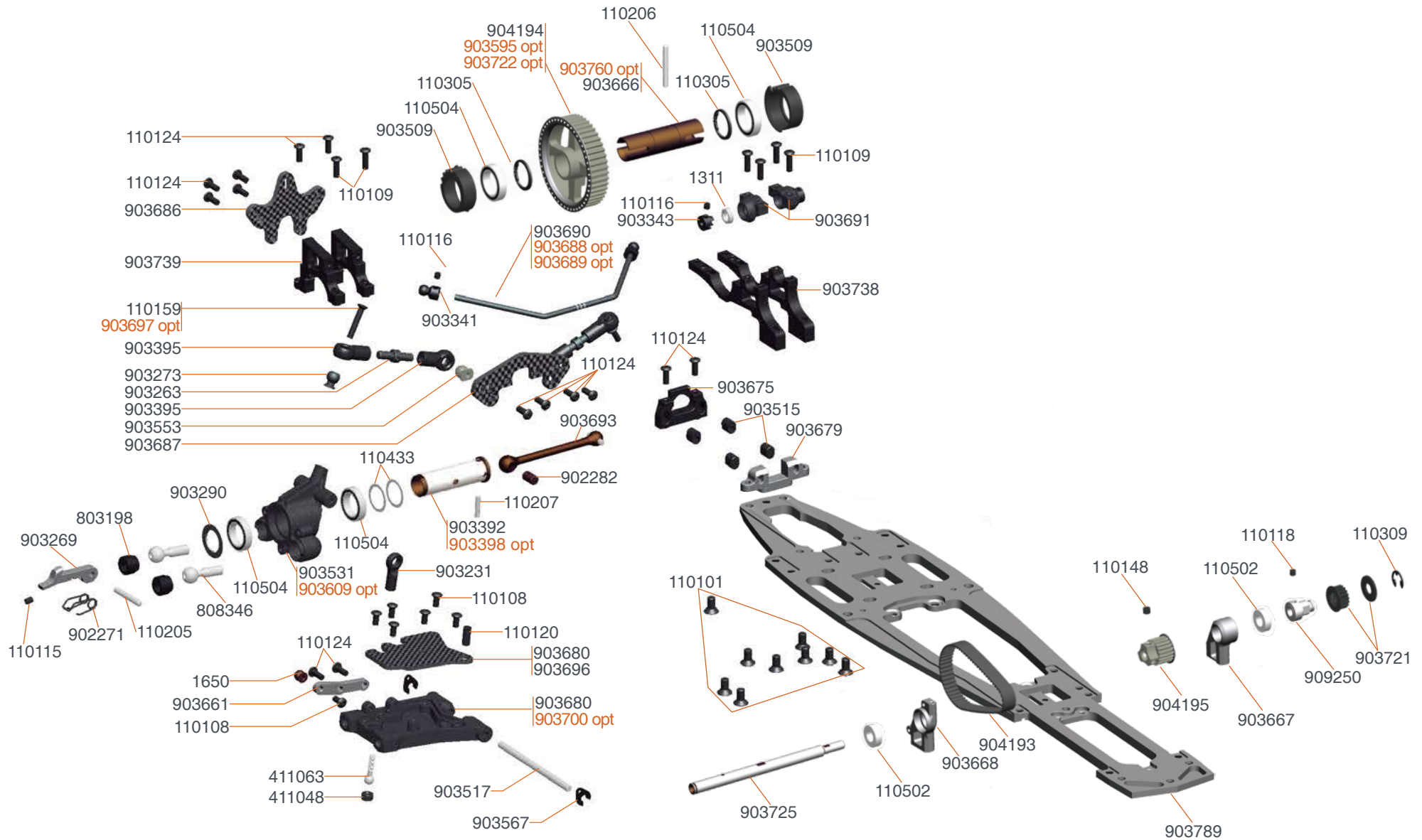

- 903398 Wheelaxle cvd RR alu (2)
- 903595 Pulley rear axle 48T alu
- 903609 Upright (2) hard
- 903688 Antirroll bar FR/RR soft S988
- 903689 Antirroll bar FR/RR medium S988

- 903697 Camberlink riser 1/8 (2)
- 903700 Wishbone RR lw L+R hard S988
- 903722 Pulley set rear (2) S989
- 903759 Chassis weight 14gr brass S989
- 903760 Solidaxle light S989



FRONT / EXPLODED VIEW

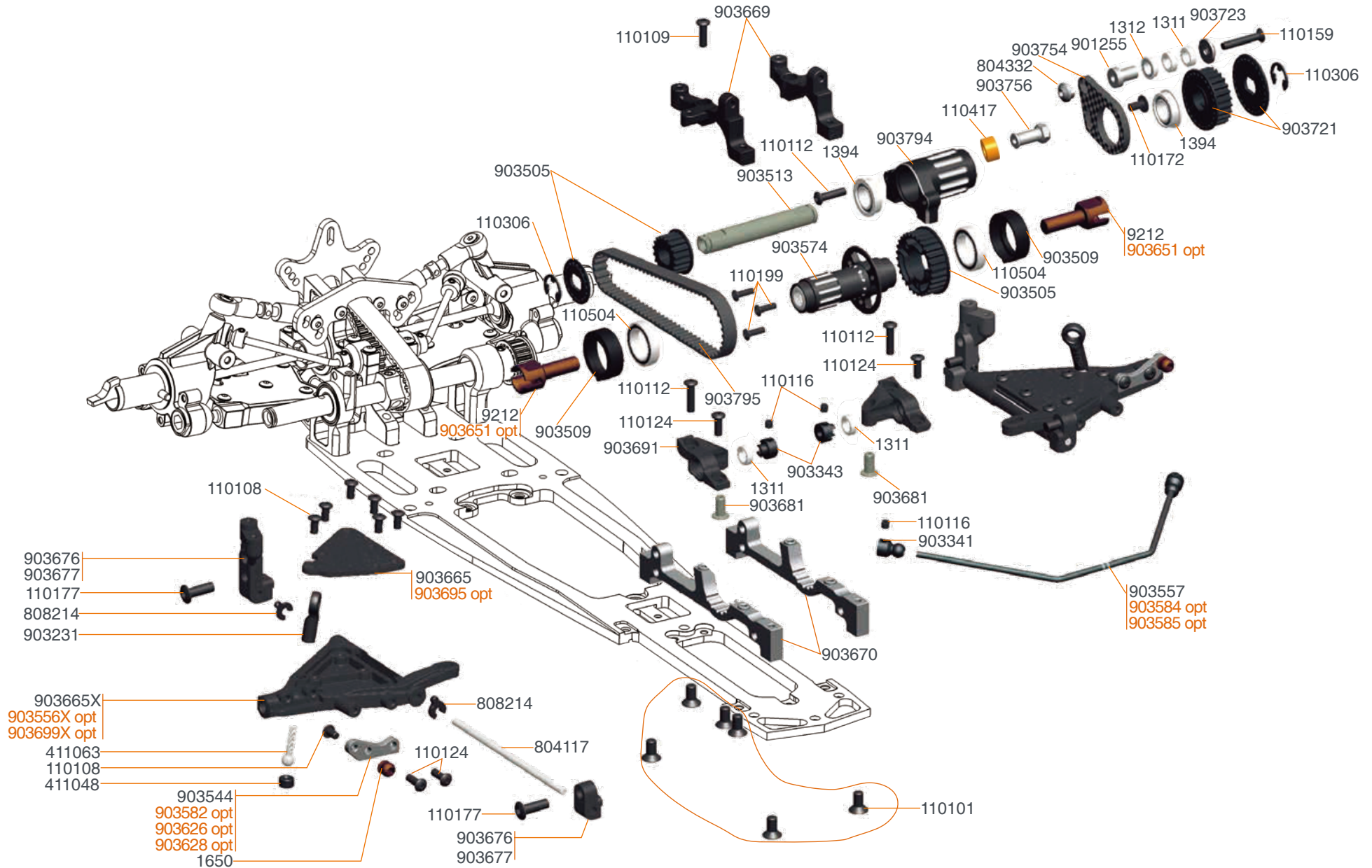

903584 Antirroll bar FR soft S989

903585 Antirroll bar FR hard S989

903582 Shock extension bracket FR carbon (2)

903626 Shock extension bracket FR wide alu (2)

903628 Shock extension bracket FR wide carbon (2)

903650 Oneway front axle Hard anodized

903651 Inner driveshaft adapter light

903695 Wishbone insert carbon FR lw (2)

903556X Wishbone FR lw V2 L+R

903699X Wishbone FR lw V2 L+R hard S988

OPT

FRONT II EXPLODED VIEW

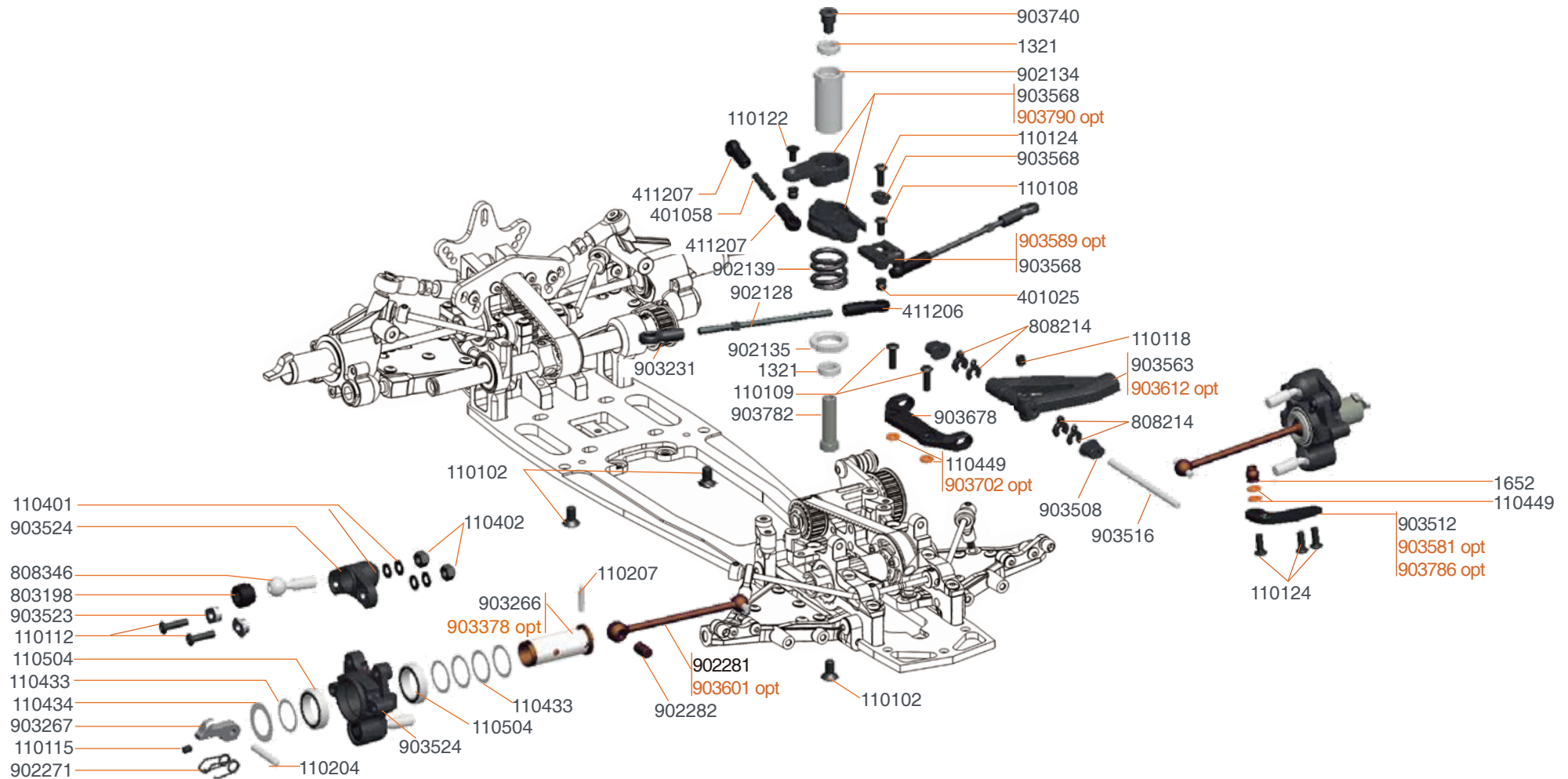

- 903378 Wheelaxle front OS2 alu (2)
- 903786 Steering lever opt 2 (2) S9
- 903581 Steeringblock lever carbon (2)
- 903589 Servosaver bottom alu (2)
- 903601 Driveshaft cvd FR alu (2)
- 903612 Wishbone FR up (2) hard
- 903702 Rollcenter spacer fr (2) S988
- 903775 Flex set S989
- 903776 Flex insert (2) S989
- 903790 Servosaver top alu

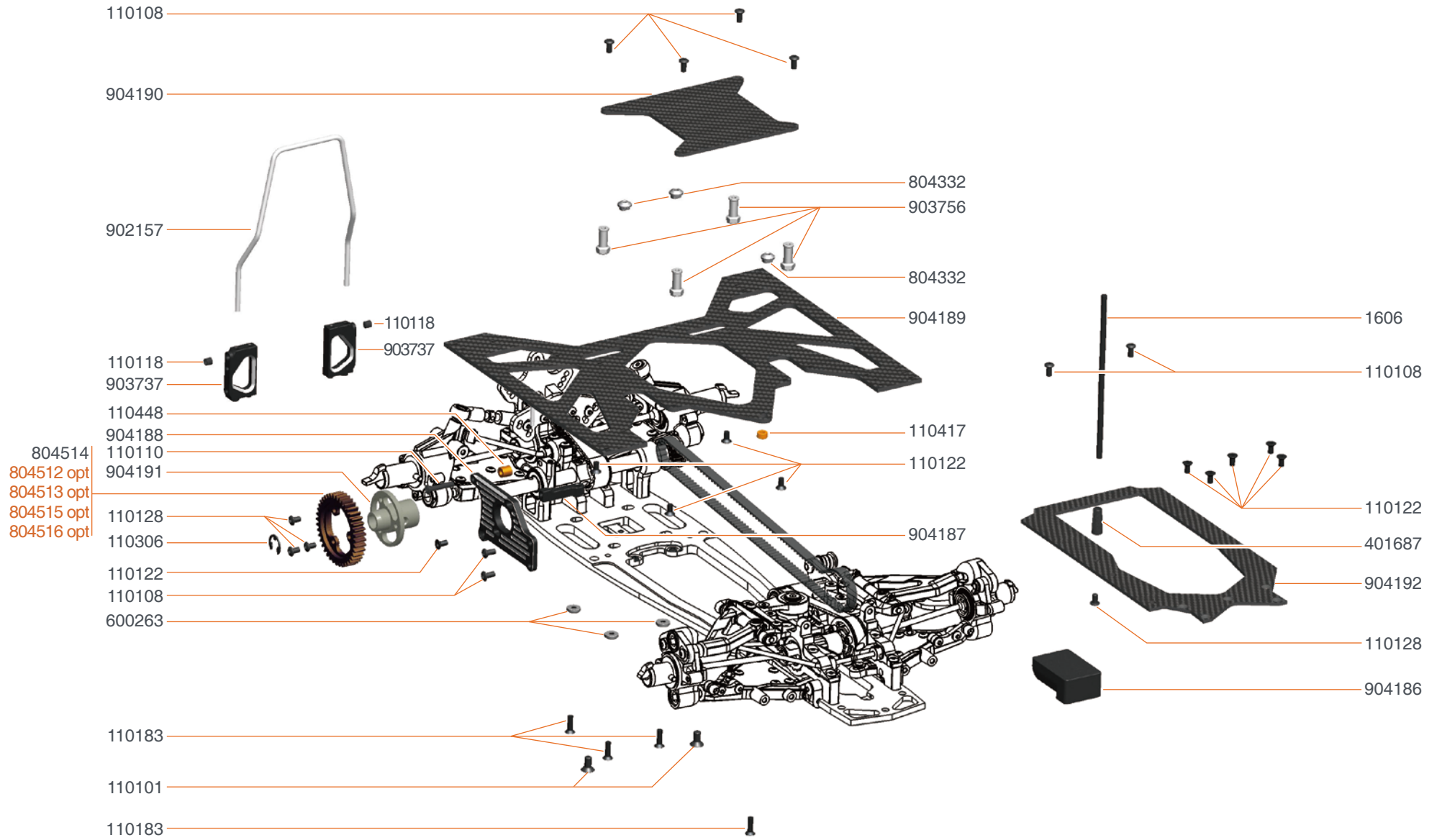

- 804512 Spur gear 36T steel M1
- 804513 Spur gear 38T steel M1
- 804515 Spur gear 42T steel M1
- 804516 Spur gear 44T steel M1



BUMPER AND BODYMOUNT EXPLODED VIEW

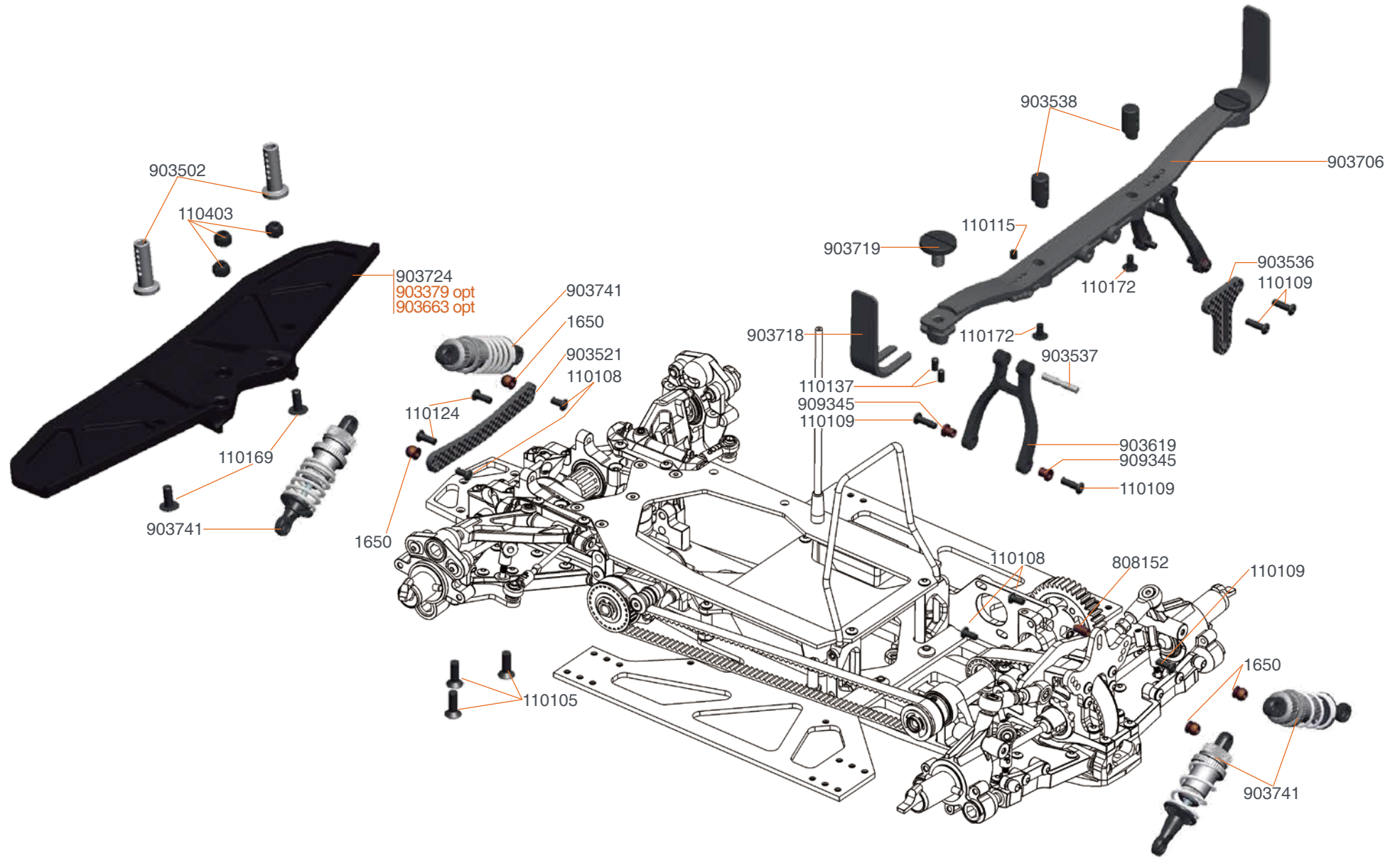

- 903379 Bumper 966 aero with inserts L+R
- 903618 Aero bumper inserts L+R 977
- 903663 Bumper 1/8 FLOW
- 903664 Bumper insert set (2+2) FLOW

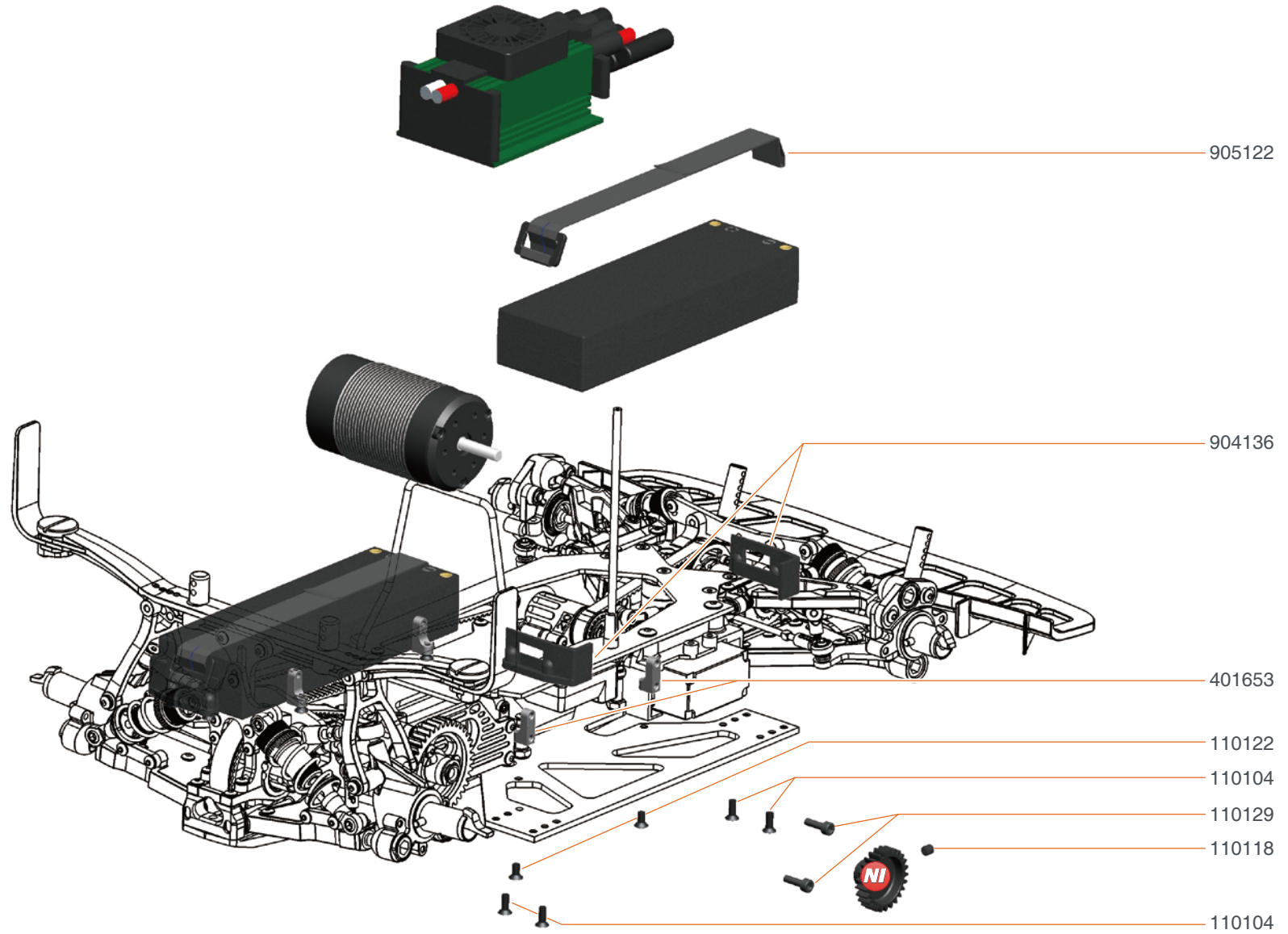

TEAM SERPENT NETWORK

989 SPARE PARTS www.serpent.com/903019/spares/



989 OPTIONALS PARTS www.serpent.com/903019/Optionals/



SERPENT TOOLS www.serpent.com/product/Tools/



SERPENT MERCHANDISING www.serpent.com/product/Merchandising/



SERPENT WEBSITE AND BLOG

www.serpent.com
www.teamserpent.com
www.dragon-rc.com

SERPENT PROMO PAGES <http://promo.serpent.com>

SERPENT FACEBOOK GROUPS <http://promo.serpent.com/indexfb.htm>

SERPENT ADVANCED MANUALS <http://promo.serpent.com/sam/>

SERPENT SOCIAL MEDIA



www.facebook.com/teamserpentrc



www.youtube.com/user/SerpentMRC



www.twitter.com/SerpentMRC



www.plus.google.com/+SerpentModelcars/posts



www.weibo.com/teamserpent

INSTRUCTION MANUAL

989E VIPER^e



Manual Viper 989E #57591-1

SERPENT