



## Front Suspension:

Ride Height: \_\_\_\_\_  
 Camber: \_\_\_\_\_  
 Toe: \_\_\_\_\_  
 Anti-Roll Bar: \_\_\_\_\_  
 Arm Type: \_\_\_\_\_  
 Tower Type: \_\_\_\_\_  
 Wheelbase Shim: \_\_\_\_\_  
 Wheel Hex: \_\_\_\_\_  
 Caster Block: 8°  9°  10°   
 Chassis Brace Support: \_\_\_\_\_  
 Top Plate Brace: \_\_\_\_\_  
 Front Axles: CVA  DCV   
 Notes: \_\_\_\_\_

1   
 2   
 Front Chassis Brace Screws: \_\_\_\_\_  
 Arm Mount A: 1°  0.5°   
 Gray  Black   
 Arm Mount B: 1°  0.5°   
 Gray  Black

Ball Stud Spacing: \_\_\_\_\_  
 Diff Height: +2  +0

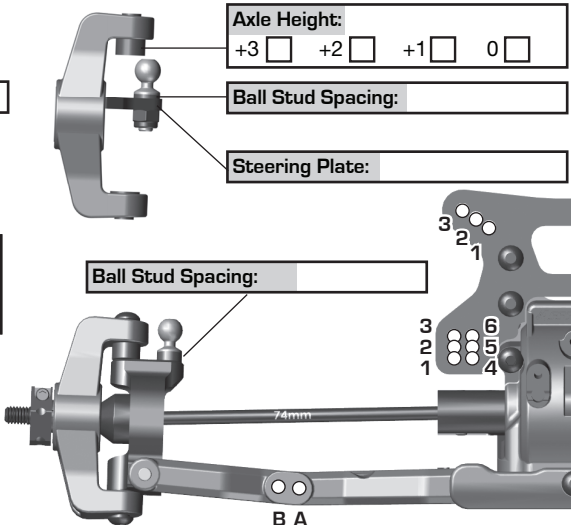
Axle Height: +3  +2  +1  0   
 Ball Stud Spacing: \_\_\_\_\_  
 Steering Plate: \_\_\_\_\_  
 Ball Stud Spacing: \_\_\_\_\_  

## Rear Suspension:

Ride Height: \_\_\_\_\_  
 Camber: \_\_\_\_\_  
 Anti-Roll Bar: \_\_\_\_\_  
 Arm Type: \_\_\_\_\_  
 Wheelbase Shim: \_\_\_\_\_  
 Wheel Hex: \_\_\_\_\_  
 Chassis Brace Support: \_\_\_\_\_  
 Hub Spacing: Fwd  Mid  Back   
 Notes: \_\_\_\_\_

Rear Chassis Brace Screws: \_\_\_\_\_  
 Arm Mount C: 1°  0.5°   
 Gray  Black   
 Arm Mount D: 1°  0.5°   
 Gray  Black

Diff Height: +3  +2  +1  +0

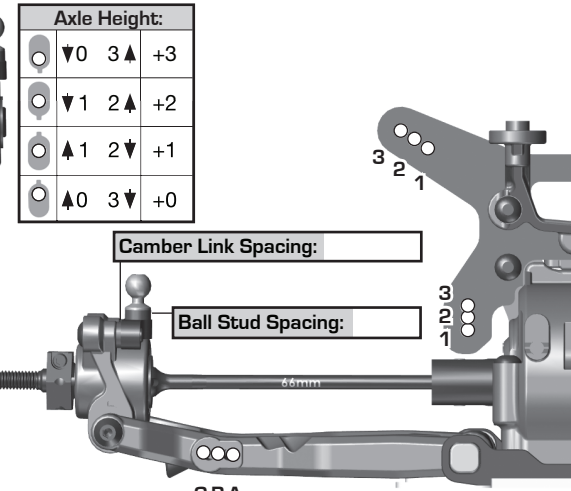
Axle Height:  0  1  2  3  
 3  2  1  0  
 2  1  0  
 1  2  3  
 0  1  2  3  
 Camber Link Spacing: \_\_\_\_\_  
 Ball Stud Spacing: \_\_\_\_\_  

## Electronics:

Radio: \_\_\_\_\_ Servo: \_\_\_\_\_  
 EPA: Throttle: \_\_\_\_\_ % Brake: \_\_\_\_\_ %  
 ESC: \_\_\_\_\_  
 ESC Settings: \_\_\_\_\_  
 Motor / Wind: \_\_\_\_\_ Timing: \_\_\_\_\_  
 Pinion: \_\_\_\_\_ Spur: \_\_\_\_\_  
 Battery: \_\_\_\_\_  
 Battery Position: Back 1  2  3  4  Forward  
 Battery Weight: \_\_\_\_\_

## Differential:

	Front	Center	Rear
Fluid:			
Gears:			
Type:			
Notes:	_____		

Slipper Clutch: Type: \_\_\_\_\_  
 # of Pads: \_\_\_\_\_  
 Setting: \_\_\_\_\_

## Shocks:

	Front	Rear
Piston:		
Thickness:		
Fluid:		
Spring:		
Limiters:	Int: _____ Ext: _____	Int: _____ Ext: _____
Stroke:		
Eyelet Length:		
Cup Offset:		
Notes:	_____	



## Track Info:

Size: Small  Medium  Large  Extra Large   
 Surface: Dirt  Carpet  Astroturf  Multi Surface   
 Traction: Low  Medium  High  Very High   
 Moisture: Dry  Damp  Wet   
 Condition: Indoor  Outdoor  Dusty  Hard Packed   
 Bumpy  Grooved  Smooth  Loamy   
 Temperature: Ambient: \_\_\_\_\_ Track: \_\_\_\_\_  
 Notes: \_\_\_\_\_  
 Vehicle Comments: \_\_\_\_\_

## Tires:

Front Tires: \_\_\_\_\_  
 Front Compound: \_\_\_\_\_  
 Front Insert: \_\_\_\_\_  
 Rear Tires: \_\_\_\_\_  
 Rear Compound: \_\_\_\_\_  
 Rear Insert: \_\_\_\_\_  
 Wheel (F/R): \_\_\_\_\_  
 Notes: \_\_\_\_\_

## Body, Wing, Weight:

Body: \_\_\_\_\_  
 Front Wing: Yes  No   
 Rear Wing: \_\_\_\_\_  
 Wing Angle: 0°  6°   
 Wing Mount Height: 0  -2   
 Servo Weights: \_\_\_\_\_  
 Electronic Weights: \_\_\_\_\_  
 Total Vehicle Weight: \_\_\_\_\_