

Name: Box Stock Date: \_\_\_\_\_ Event: \_\_\_\_\_ Ambient Temp: \_\_\_\_\_

Track: INDOOR  OUTDOOR  Size: SMALL  MEDIUM  LARGE  Traction: LOW  MEDIUM  HIGH

Surface: SMOOTH  BUMPY  RUTTED  Type: LOOSE / LOAMY  HARD PACKED  BLUE GROOVE  CLAY  ASTRO

## Ackerman/Bumpsteer/Servo Saver

Condition: DUSTY  DRY  WET  MUDDY



WASHERS:

2



FULL  
TURNS  
FROM  
FULLY  
TIGHT

## Front End:

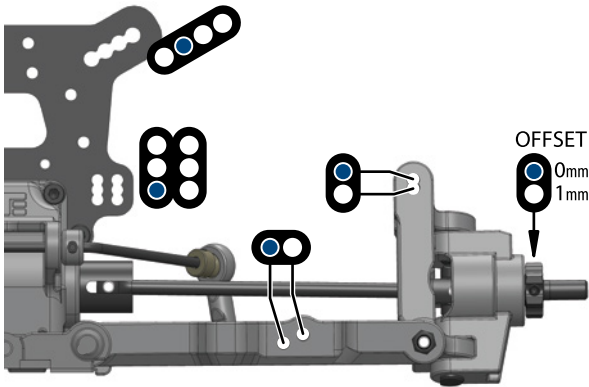

## Suspension:

RIDE HEIGHT: 24 CAMBER: -2°  
 CASTER BLOCK: 18° SWEEP: 0°  
 KICK UP: 10° TOE: 2.0° out  
 SWAY BAR: 2.1mm DROOP: 98mm

## Shocks:

OIL: 700 CST BRAND: Kit  
 PISTON: TKR6705E SPRING: TKR6107  
 REBOUND: 0% BUILD: emul

## Differentials:

OPTION	FRONT	CENTER	REAR
<b>Diff Oil</b>	15k	15k	10k
(TKR5145B)	<input type="radio"/>	<input type="radio"/>	<input type="radio"/>
(TKR5145C)	<input type="radio"/>	<input type="radio"/>	<input type="radio"/>
(TKR9114)	<input type="radio"/>	<input type="radio"/>	<input type="radio"/>
(TKR9114HD)	<input type="radio"/>	<input type="radio"/>	<input type="radio"/>
(TKR51114XB)	<input type="radio"/>	<input type="radio"/>	<input type="radio"/>
(TKR5150)	<input type="radio"/>	<input type="radio"/>	<input type="radio"/>
(TKR5150B)	<input type="radio"/>	<input type="radio"/>	<input type="radio"/>
(TKR5113B)	<input type="radio"/>	<input type="radio"/>	<input type="radio"/>
(TKR5113S)	<input type="radio"/>	<input type="radio"/>	<input type="radio"/>
(TKR5113)	<input type="radio"/>	<input type="radio"/>	<input type="radio"/>
(TKR5149X)	<input type="radio"/>	<input type="radio"/>	<input type="radio"/>
(TKR5149A)	<input type="radio"/>	<input type="radio"/>	<input type="radio"/>
(TKR5149)	<input type="radio"/>	<input type="radio"/>	<input type="radio"/>

## Rear End:

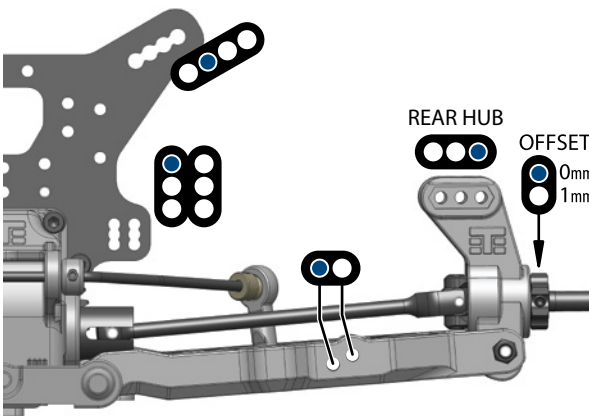

## Suspension:

RIDE HEIGHT: 24 CAMBER: -2°  
 ANTI-SQUAT: 1° TOE: 2.5°  
 SWAY BAR: 2.1mm DROOP: 108mm

## Shocks:

OIL: 600 CST BRAND: Kit  
 PISTON: TKR6705E SPRING: TKR6037  
 REBOUND: 0% BUILD: emul

## Drivetrain:

PINION/SPUR: / 41

## Equipment:

ESC: \_\_\_\_\_  
 BATTERY: \_\_\_\_\_  
 MOTOR: \_\_\_\_\_  
 SERVO: 250 oz/in minimum

## Wheelbase:

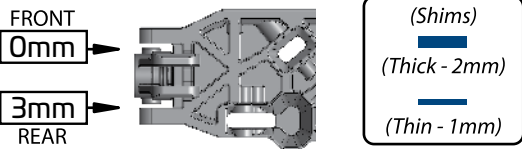

## Optional Hinge Pin Braces:

### "A" Block:

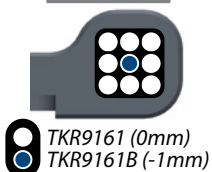

### "B" Block:

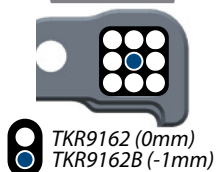

### "C" Block:

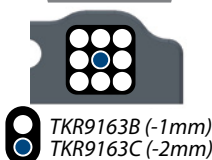

### "D" Block:

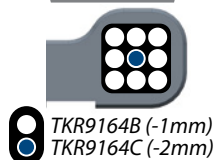

## Chassis Braces:

TURNBUCKLE BRACE:  CENTER BRACE:   
 REAR BRACE:

## Tires / Wheels:

BRAND / TREAD: \_\_\_\_\_  
 COMPOUND: \_\_\_\_\_  
 INSERT: \_\_\_\_\_  
 WHEEL: \_\_\_\_\_  
 NOTES: \_\_\_\_\_

## Body/Body Mounts:

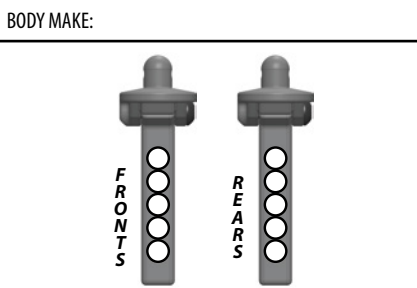

## Notes: