

1/12 LUXURY PAN CAR

XRAY X12



INSTRUCTION MANUAL
FOR X12'23 EU & US EDITION

BEFORE YOU START

This is a high-competition, high-quality RC car intended for persons aged 16 years and older with previous experience building and operating RC model racing cars. This is not a toy; it is a precision racing model. This model racing car is not intended for use by beginners, inexperienced customers, or by children without direct supervision of a responsible, knowledgeable adult. If you do not fulfill these requirements, please return the kit in unused and unassembled form back to the shop where you have purchased it.

Before building and operating your XRAY, **YOU MUST** read through all of the operating instructions and instruction manual and fully understand them to get the maximum enjoyment and prevent unnecessary damage.

CUSTOMER SUPPORT

We have made every effort to make these instructions as easy to understand as possible. However, if you have any difficulties, problems, or questions, please do not hesitate to contact the XRAY support team at info@teamxray.com. Also, please visit our Web site at www.teamxray.com to find the latest updates, set-up information, option parts, and many other goodies. We pride ourselves on taking excellent care of our customers.

You can join thousands of XRAY fans and enthusiasts in our online community at: www.teamxray.com

Carefully read and fully understand the instructions before beginning assembly.

Make sure you review this entire manual, download and use set-up book from the Web, and examine all details carefully. If for some reason you decide this is not what you wanted or expected, **do not continue any further**. Your hobby dealer can not accept your kit for return or exchange after it has been partially or fully assembled.

Contents of the box may differ from pictures. In line with our policy of continuous product development, the exact specifications of the kit may vary without prior notice.

XRAY Europe

K Vystavisku 6992
91101 Trenčín
Slovakia, EUROPE
Phone: 421-32-7401100
Fax: 421-32-7401109
E-mail: info@teamxray.com

XRAY USA

RC America, 2030 Century Center Blvd #15
Irving, TX 75062
USA
Phone: (214) 744-2400
Fax: (214) 744-2401
E-mail: xray@rcamerica.com

FAILURE TO FOLLOW THESE INSTRUCTIONS WILL BE CONSIDERED AS ABUSE AND/OR NEGLIGENCE.

SAFETY PRECAUTIONS

Contains:

LEAD (CAS 7439-92-1) ANTIMONY (CAS 7440-36-0)

WARNING: This product contains a chemical known to the state of California to cause cancer and birth defects or other reproductive harm.

CAUTION: CANCER HAZARD

Contains lead, a listed carcinogen. Lead is harmful if ingested. Wash thoroughly after using. DO NOT use product while eating, drinking or using tobacco products. May cause chronic effects to gastrointestinal tract, CNS, kidneys, and blood. MAY CAUSE BIRTH DEFECTS.

When building, using and/or operating this model always wear protective glasses and gloves.

Take appropriate safety precautions prior to operating this model. You are responsible for this model's assembly and safe operation! Please read the instruction manual before building and operating this model and follow all safety precautions. Always keep the instruction manual at hand for quick

reference, even after completing the assembly. Use only genuine and original authentic XRAY parts for maximum performance. Using any third party parts on this model will void guaranty immediately.

Improper operation may cause personal and/or property damage. XRAY and its distributors have no control over damage resulting from shipping, improper construction, or improper usage. XRAY assumes and accepts no responsibility for personal and/or property damages resulting from the use of improper building materials, equipment and operations. By purchasing any item produced by XRAY, the buyer expressly warrants that he/she is in compliance with all applicable federal, state and local laws and regulation regarding the purchase, ownership and use of the item. The buyer expressly agrees to indemnify and hold harmless XRAY for all claims resulting directly or indirectly from the purchase, ownership or use of the product. By the act of assembling or operating this product, the user accepts all resulting liability. If the buyer is not prepared to accept this liability, then he/she should return this kit in new, unassembled, and unused condition to the place of purchase.



IMPORTANT NOTES - GENERAL

- This product is not suitable for children under 16 years of age without the direct supervision of a responsible and knowledgeable adult.
- Carefully read all manufacturers warnings and cautions for any parts used in the construction and use of your model.
- Assemble this kit only in places away from the reach of very small children.
- First-time builders and users should seek advice from people who have building experience in order to assemble the model correctly and to allow the model to reach its performance potential.
- Exercise care when using tools and sharp instruments.
- Take care when building, as some parts may have sharp edges.
- Keep small parts out of reach of small children. Children must not be allowed to put any parts in their mouth, or pull vinyl bag over their head.
- Read and follow instructions supplied with paints and/or cement, if used (not included in kit).
- Immediately after using your model, do NOT touch equipment on the model such as the motor and speed controller, because they generate high temperatures. You may seriously burn yourself seriously touching them.
- Follow the operating instructions for the radio equipment at all times.
- Do not put fingers or any objects inside rotating and moving parts, as this may cause damage or serious injury as your finger, hair, clothes, etc. may get caught.
- Be sure that your operating frequency is clear before turning on or running your model, and never share the same frequency with somebody else at the same time. Ensure that others are aware of the operating frequency you are using and when you are using it.
- Use a transmitter designed for ground use with RC cars. Make sure that no one else is using the same frequency as yours in your operating area. Using the same frequency at the same time, whether it is driving, flying or sailing, can cause loss of control of the RC model, resulting in a serious accident.
- Always turn on your transmitter before you turn on the receiver in the car. Always turn off the receiver before turning your transmitter off.
- Keep the wheels of the model off the ground when checking the operation of the radio equipment.
- Disconnect the battery pack before storing your model.
- When learning to operate your model, go to an area that has no obstacles that can damage your model if your model suffers a collision.
- Remove any sand, mud, dirt, grass or water before putting your model away.
- If the model behaves strangely, immediately stop the model, check and clear the problem.
- To prevent any serious personal injury and/or damage to property, be responsible when operating all remote controlled models.
- The model car is not intended for use on public places and roads or areas where its operation can conflict with or disrupt pedestrian or vehicular traffic.
- Because the model car is controlled by radio, it is subject to radio interference from many sources that are beyond your control. Since radio interference can cause momentary loss of control, always allow a safety margin in all directions around the model in order to prevent collisions.
- Do not use your model:
 - Near real cars, animals, or people that are unaware that an RC car is being driven.
 - In places where children and people gather
 - In residential districts and parks
 - In limited indoor spaces
 - In wet conditions
 - In the street
 - In areas where loud noises can disturb others, such as hospitals and residential areas.
 - At night or anytime your line of sight to the model may be obstructed or impaired in any way.

To prevent any serious personal injury and/or damage to property, please be responsible when operating all remote controlled models.

XRAY

IMPORTANT NOTES - ELECTRICAL

- Insulate any exposed electrical wiring (using heat shrink tubing or electrical tape) to prevent dangerous short circuits. Take maximum care in wiring, connecting and insulating cables. Make sure cables are always connected securely. Check connectors for if they become loose. And if so, reconnect them securely. Never use RC models with damaged wires. A damaged wire is extremely dangerous, and can cause short-circuits resulting in fire. Please have wires repaired at your local hobby shop.
- Low battery power will result in loss of control. Loss of control can occur due to a weak battery in either the transmitter or the receiver. Weak running battery may also result in an out of control car if your car's receiver power is supplied by the running battery. Stop operation immediately if the car starts to slow down.
- When not using RC model, always disconnect and remove battery.
- Do not disassemble battery or cut battery cables. If the running battery short-circuits, approximately 300W of electricity can be discharged, leading to fire or burns. Never disassemble battery or cut battery cables.
- Use a recommended charger for the receiver and transmitter batteries and follow the instructions correctly. Over-charging, incorrect charging,

or using inferior chargers can cause the batteries to become dangerously hot. Recharge battery when necessary. Continual recharging may damage battery and, in the worst case, could build up heat leading to fire. If battery becomes extremely hot during recharging, please ask your local hobby shop for check and/or repair and/or replacement.

- Regularly check the charger for potential hazards such as damage to the cable, plug, casing or other defects. Ensure that any damage is rectified before using the charger again. Modifying the charger may cause short-circuit or overcharging leading to a serious accident. Therefore do not modify the charger.
- Always unplug charger when recharging is finished.
- Do not recharge battery while battery is still warm. After use, battery retains heat. Wait until it cools down before charging.
- Do not allow any metal part to short circuit the receiver batteries or other electrical/electronic device on the model.
- Immediately stop running if your RC model gets wet as may cause short circuit.
- Please dispose of batteries responsibly. Never put batteries into fire.

R/C & BUILDING TIPS

- Make sure all fasteners are properly tightened. Check them periodically.
- Make sure that chassis screws do not protrude from the chassis.
- For the best performance, it is very important that great care is taken to ensure the free movement of all parts.
- Clean all ball-bearings so they move very easily and freely.
- Tap or pre-thread the plastic parts when threading screws.
- Self-tapping screws cut threads into the parts when being tightened. Do not use excessive force when tightening the self-tapping screws because you may strip out the thread in the plastic. We recommended you stop tightening a screw when you feel some resistance.
- Ask your local hobby shop for any advice.

Please support your local hobby shop. We at XRAY Model Racing Cars support all local hobby dealers. Therefore we ask you, if at all possible, to purchase XRAY products at your hobby dealer and give them your support like we do. If you have difficulty finding XRAY products, please check out www.teamxray.com to get advice, or contact us via email at info@teamxray.com, or contact the XRAY distributor in your country.

WARRANTY

XRAY guarantees this model kit to be free from defects in both material and workmanship within 30 days of purchase. The total monetary value under warranty will in no case exceed the cost of the original kit purchased. This warranty does not cover any components damaged by use or modification or as a result of wear. Part or parts missing from this kit must be reported within 30 days of purchase. No part or parts will be sent under warranty without proof of purchase. Should you find a defective or missing part, contact the local distributor. Service and customer support will be provided through local hobby store where you have purchased the kit, therefore make sure to purchase any XRAY products at your local hobby store. This model racing car is considered to be a high-performance racing vehicle. As such this vehicle will be used in an extreme range of conditions and situations, all which may cause premature wear or failure of any component. XRAY has no control over usage of vehicles once they leave the dealer, therefore XRAY can only offer warranty against all manufacturer's defects in materials, workmanship, and assembly at point of sale and before use. No warranties are expressed or implied that cover damage caused by what is considered normal use, or cover or imply how long any model cars' components or electronic components will last before requiring replacement.

Due to the high performance level of this model car you will need to periodically maintain and replace consumable components. Any and all warranty coverage will not cover replacement of any part or component damaged by neglect, abuse, or improper or unreasonable use. This includes

but is not limited to damage from crashing, chemical and/or water damage, excessive moisture, improper or no maintenance, or user modifications which compromise the integrity of components. Warranty will not cover components that are considered consumable on RC vehicles. XRAY does not pay nor refund shipping on any component sent to XRAY or its distributors for warranty. XRAY reserves the right to make the final determination of the warranty status of any component or part.

Limitations of Liability

XRAY makes no other warranties expressed or implied. XRAY shall not be liable for any loss, injury or damages, whether direct, indirect, special, incidental, or consequential, arising from the use, misuse, or abuse of this product and/or any product or accessory required to operate this product. In no case shall XRAY's liability exceed the monetary value of this product.

Take adequate safety precautions prior to operating this model. You are responsible for this model's assembly and safe operation.

Disregard of the any of the above cautions may lead to accidents, personal injury, or property damage. XRAY MODEL RACING CARS assumes no responsibility for any injury, damage, or misuse of this product during assembly or operation, nor any addictions that may arise from the use of this product.

All rights reserved.

QUALITY CERTIFICATE

XRAY MODEL RACING CARS uses only the highest quality materials, the best compounds for molded parts and the most sophisticated manufacturing processes of TQM (Total Quality Management). We guarantee that all parts of a newly-purchased kit are manufactured with the highest regard to quality. However, due to the many factors inherent in model racecar competition, we

cannot guarantee any parts once you start racing the car. Products which have been worn out, abused, neglected or improperly operated will not be covered under warranty.

We wish you enjoyment of this high-quality and high-performance RC car and wish you best success on the track!

In line with our policy of continuous product development, the exact specifications of the kit may vary. In the unlikely event of any problems with your new kit, you should contact the model shop where you purchased it, quoting the part number.

We do reserve all rights to change any specification without prior notice. All rights reserved.

TOOLS REQUIRED

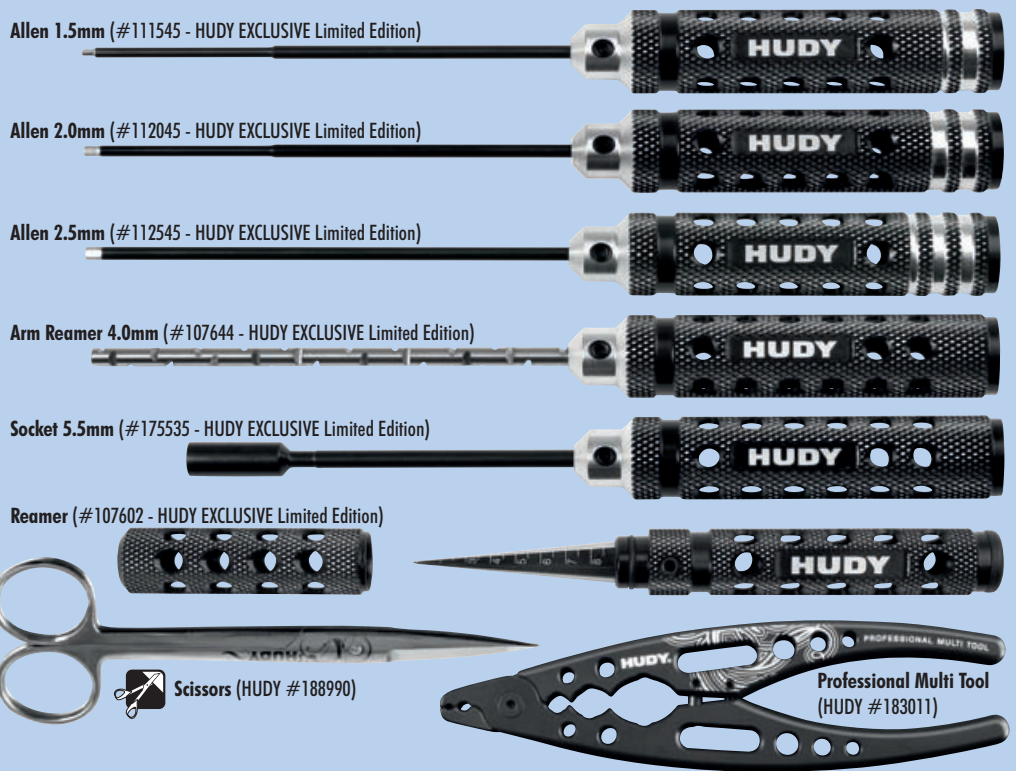

NOT INCLUDED



Alexander Hagberg
(Factory Driver)

VIDEO TECH TIP



When a QR CODE is found in the instruction manual, scan the code to be directed to an online video that explains that feature or adjustment in more detail. Make sure to watch all of the instructional videos to get the most performance out of your car.



SAMPLE OF OPTIONAL PARTS

OPTION	TYPE	OPTION
#37XXX	TYPE1	OPTION 1
#37XXX	TYPE2	OPTION 2
#37XXX	TYPE3	INCLUDED

XRAY offers wide range of OPTIONAL TUNING PARTS which are listed in a table like this. Please refer to the exploded view of each main section to verify which part is included in the kit while all other parts are available only as an optional part and must be purchased separately.

COLOR INDICATIONS

At the beginning of each section is an exploded view of the parts to be assembled. There is also a list of all the parts and part numbers that are related to the assembly of that section.

The part descriptions are color-coded to make it easier for you to identify the source of a part. Here are what the different colors mean:

- 371212 STYLE A** - indicates parts that are included in the bag marked for the section.
- 371119 STYLE B** - indicates parts that are included in the box.
- 378002 STYLE C** - indicates parts that are already assembled from previous steps.

INCLUDED

* Kit includes smaller but sufficient amount of oil and grease to build the car.

450cSt (#106345)
HUDY Premium Silicone Oils



10.000cSt (#106510)
HUDY Premium Silicone Oils



ALSO REQUIRED

<p>Transmitter</p>	<p>Receiver</p>	<p>Speed Controller</p>	<p>Steering Servo</p>
<p>Electric Motor & Pinion Gear with Setscrew</p>	<p>LiPo Battery</p>	<p>Battery Charger</p>	<p>Bearing Oil (HUDY #106230)</p>
<p>Tires</p>	<p>1/12 Bodyshell</p>	<p>Lexan™ Paint</p>	<p>Double-sided Tape (HUDY #107875)</p>

1. FRONT SUSPENSION

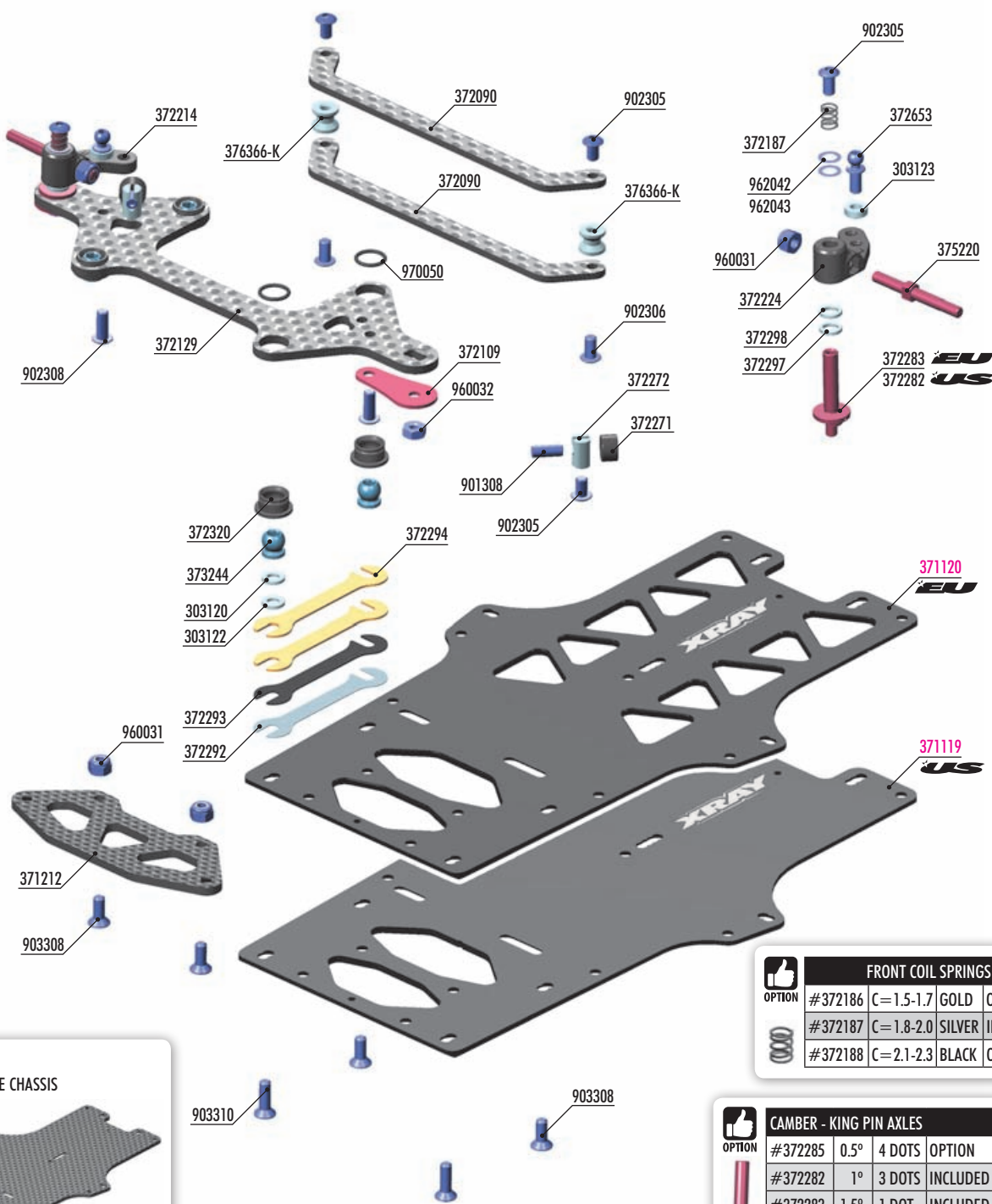

FRONT COIL SPRINGS			
	OPTION	#372186	C=1.5-1.7 GOLD OPTION
		#372187	C=1.8-2.0 SILVER INCLUDED
		#372188	C=2.1-2.3 BLACK OPTION

CAMBER - KING PIN AXLES			
	OPTION	#372285	0.5° 4 DOTS OPTION
		#372282	1° 3 DOTS INCLUDED
		#372283	1.5° 1 DOT INCLUDED
		#372284	2° 2 DOTS OPTION

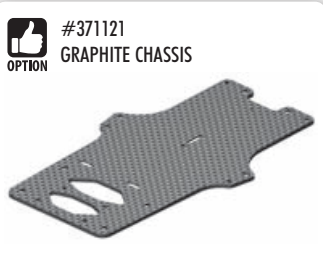

BAG
01



- | | | | |
|--------|--|----------|--|
| 303120 | SET OF ALU SHIM (0.5MM, 1.5MM, 2.5MM) | 372653 | BALL END 4.2MM WITH 8MM THREAD (2) |
| 303122 | ALU SHIM 3x6x1.0MM (10) | 373244 | BALL END 6.0MM WITH HEX - HUDY SPRING STEEL™ (2) |
| 303123 | ALU SHIM 3x6x2.0MM (10) | 375220 | FRONT WHEEL AXLE (2) |
| 371212 | GRAPHITE BUMPER LOWER HOLDER 2.5MM | 376366-K | ALU MOUNT 6.0MM - BLACK (2) |
| 372090 | FRONT BRACE - GRAPHITE 2.2MM | | |
| 372109 | STEEL LOWER SUSPENSION ARM BRACE (2) | 901308 | HEX SCREW SB M3x8 (10) |
| 372129 | GRAPHITE LOWER SUSPENSION ARM PLATE FOR STEERING LOCK 2.5MM | 902305 | HEX SCREW SH M3x5 (10) |
| 372187 | FRONT COIL SPRING FOR 4MM PIN C=1.8-2.0 - SILVER (2) | 902306 | HEX SCREW SH M3x6 (10) |
| 372214 | COMPOSITE STEERING BLOCK FOR 4MM KING PIN - RIGHT - GRAPHITE | 902308 | HEX SCREW SH M3x8 (10) |
| 372224 | COMPOSITE STEERING BLOCK FOR 4MM KING PIN - LEFT - GRAPHITE | 903308 | HEX SCREW SFH M3x8 (10) |
| 372271 | COMPOSITE STEERING BLOCK BACKSTOP (2) | 903310 | HEX SCREW SFH M3x10 (10) |
| 372272 | ALU STEERING LOCK (2) | 960031 | ALU NUT M3 (10) |
| 372282 | X12 KING PIN 4MM - 1° - NICKEL COATED (2) | 960032 | NUT M3 (10) |
| 372283 | X12 KING PIN 4MM - 1.5° - NICKEL COATED (2) | 962042 | WASHER S 4x6x0.1 (10) |
| 372292 | STEEL SHIM 0.2MM - SILVER (2) | 962043 | WASHER S 4x6x0.2 (10) |
| 372293 | STEEL SHIM 0.4MM - BLACK (2) | 970050 | O-RING 5x1 (10) |
| 372294 | STEEL SHIM 0.6MM - GOLD (2) | | |
| 372297 | ALU SHIM 4x6x1.0MM (10) | 371119 | X12 ALU SOLID CHASSIS 2.0MM - 7075 T6 |
| 372298 | ALU SHIM 4x6x0.5MM (10) | 371120 | X12 ALU FLEX CHASSIS 2.0MM - 7075 T6 |
| 372320 | COMPOSITE ARM BUSHING (4) | | |

1. FRONT SUSPENSION

★ **EU** ★ **US**



970050
O 5x1

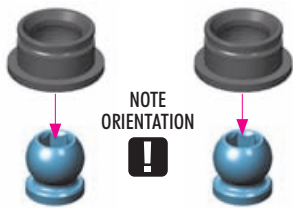

NOTE ORIENTATION !

TIP Install the balls with Professional Multi Tool. (HUDY #183011)



2x L=R

CUTAWAY VIEW

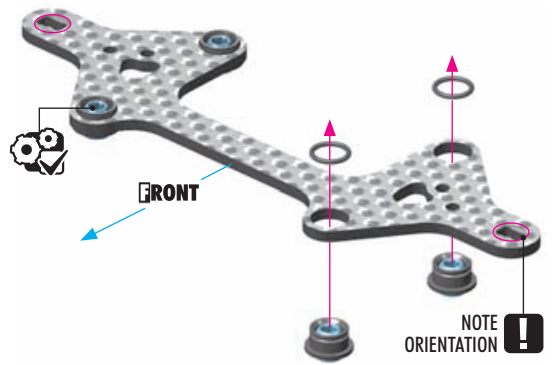

NOTE ORIENTATION !



901308
SB M3x8

2x Adjust the position of the stopper to adjust the maximum amount of steering lock.

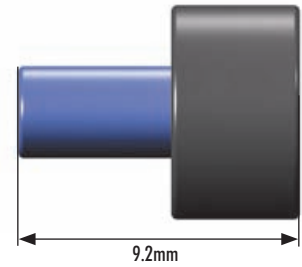
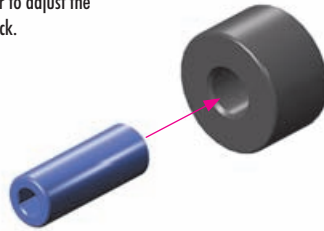

9.2mm

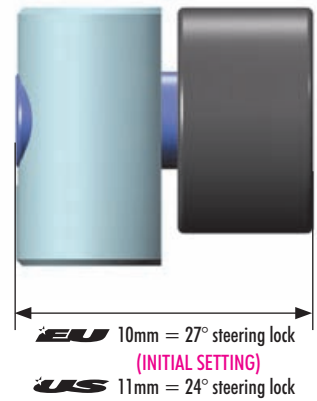
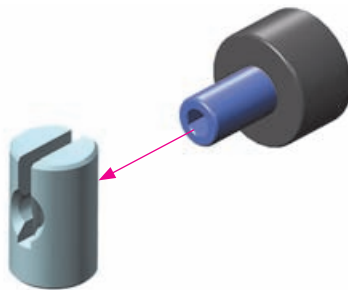

EU 10mm = 27° steering lock
(INITIAL SETTING)
US 11mm = 24° steering lock



902305
SH M3x5

The front suspension arm includes adjustable steering lock limiters. These physically limit the maximum steering angle and improve consistency during cornering.

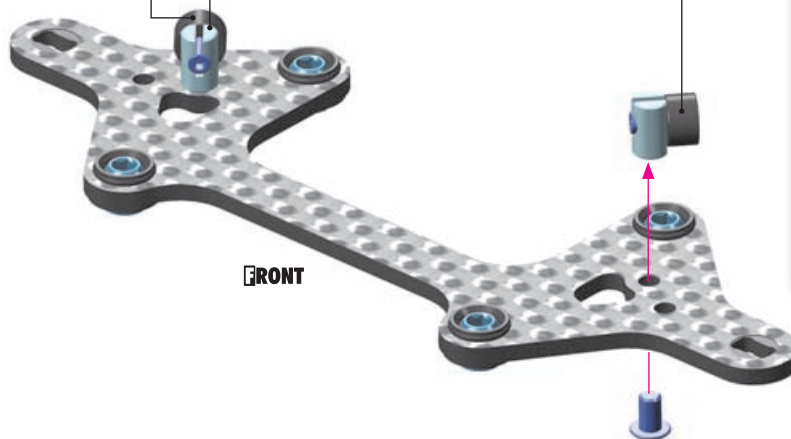

FRONT

It is recommended to start with:

★ **EU** = 27° steering lock
★ **US** = 24° steering lock

Greater steering lock improves off power steering and reactivity in tight corners but can make the car more difficult to drive in chicanes.

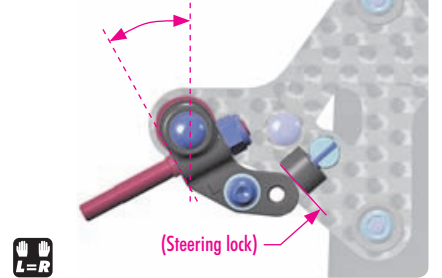

(Steering lock)

L=R



VIDEO TECH TIP



STEERING SYSTEM



2x
L=R

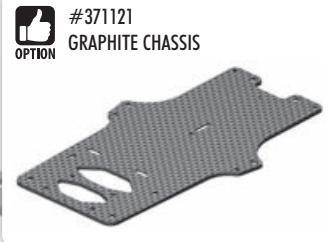
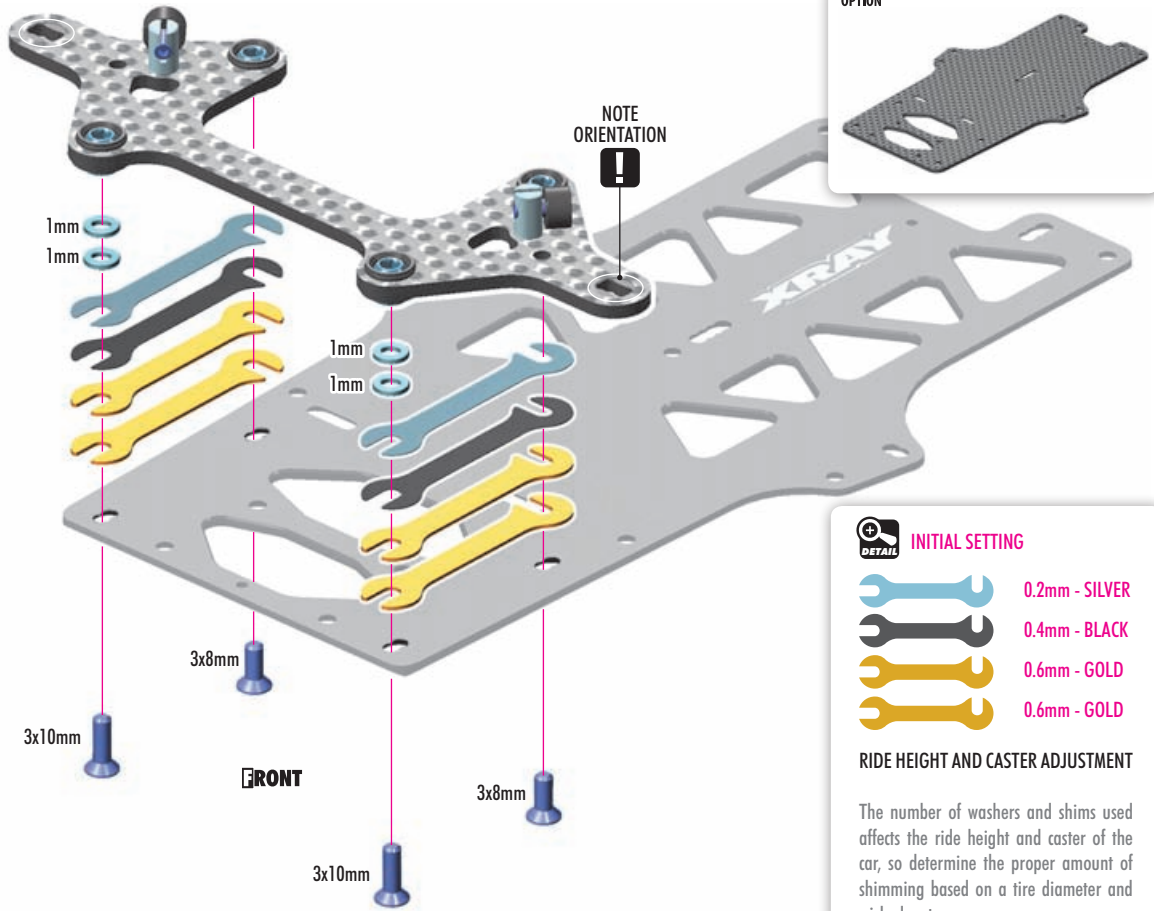

INITIAL SETTING

- 0.2mm - SILVER
- 0.4mm - BLACK
- 0.6mm - GOLD
- 0.6mm - GOLD

RIDE HEIGHT AND CASTER ADJUSTMENT

The number of washers and shims used affects the ride height and caster of the car, so determine the proper amount of shimming based on a tire diameter and wished caster.



CASTER ADJUSTMENT SETTING

Caster is adjusted by the shims placed under front ball.

Please see the table beneath the to understand how to set caster.

EXTRA SHIM UNDER FRONT BALL	
SHIM DIFFERENCE	CASTER
1mm	1.5°
2mm	3°
3mm	4.5°
4mm	6°
5mm	7.5°

(INITIAL SETTING)

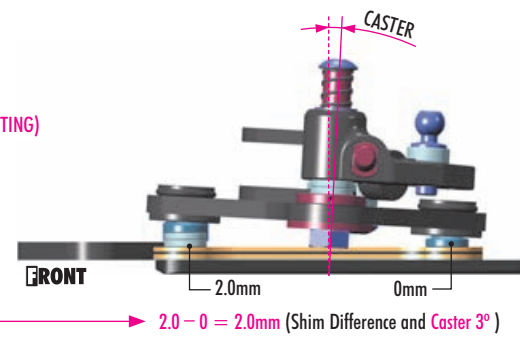

ALTERNATIVE FRONT POSITION LONG WHEELBASE

(INITIAL SETTING)

Longer wheelbase is recommended for bigger tracks with longer sweepers. Makes the car more stable and easier to drive.

FRONT WHEELBASE ADJUSTMENT

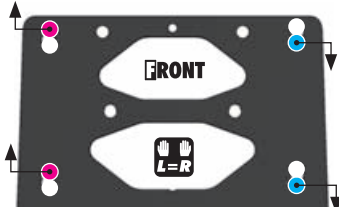

ALTERNATIVE REAR POSITION SHORT WHEELBASE

Shorter wheelbase allows the car to rotate better in corner to maintain cornering speed. Recommended for tight, technical tracks or tracks with numerous 180° hairpin corners.

FRONT SUSPENSION FLEX SETTING

-  902305
SH M3x5
-  902306
SH M3x6
-  902308
SH M3x8

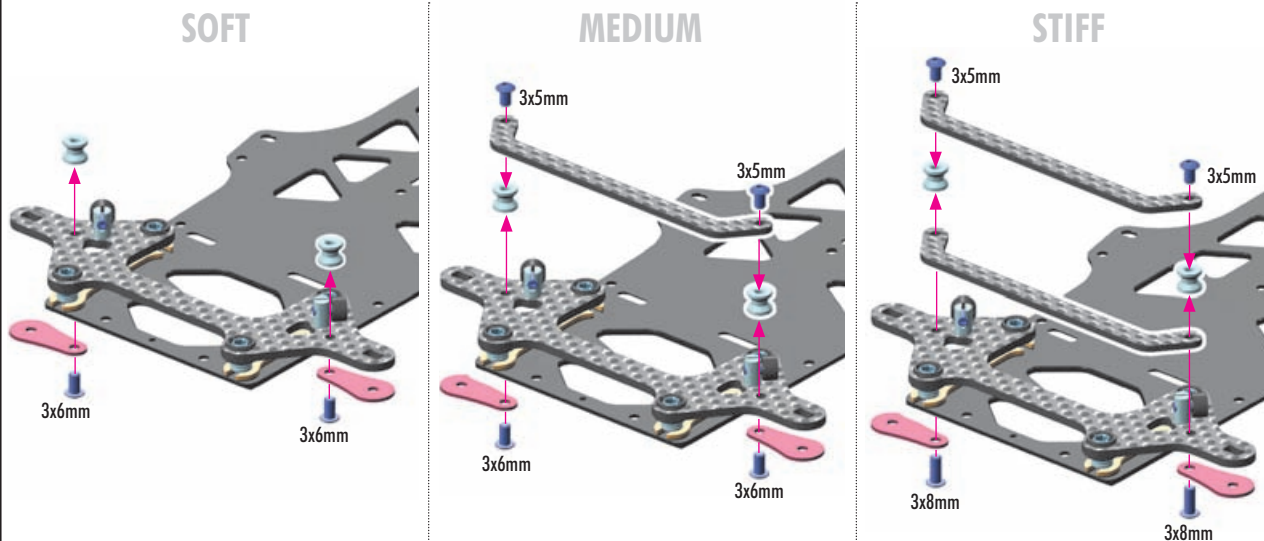

SOFT - (NO BRACE)

Makes the car initially less responsive, but will provide more mechanical grip. Recommended for low-grip carpet conditions, and asphalt.

MEDIUM (INITIAL SETTING)

Brace mounted to the graphite arm with posts provides a balance between initial response and mechanical grip. Recommended for most conditions.

STIFF

Both braces mounted to the graphite arm gives maximum responsiveness but decreases mechanical grip. Recommended for high-traction conditions (such as US black carpet).

-  303123
SHIM 3x6x2

-  960031
ALU N M3

2x 

The steering link mounting position on the steering block has a direct effect on the Ackermann. Please see the ACKERMANN SETTING page: 27.

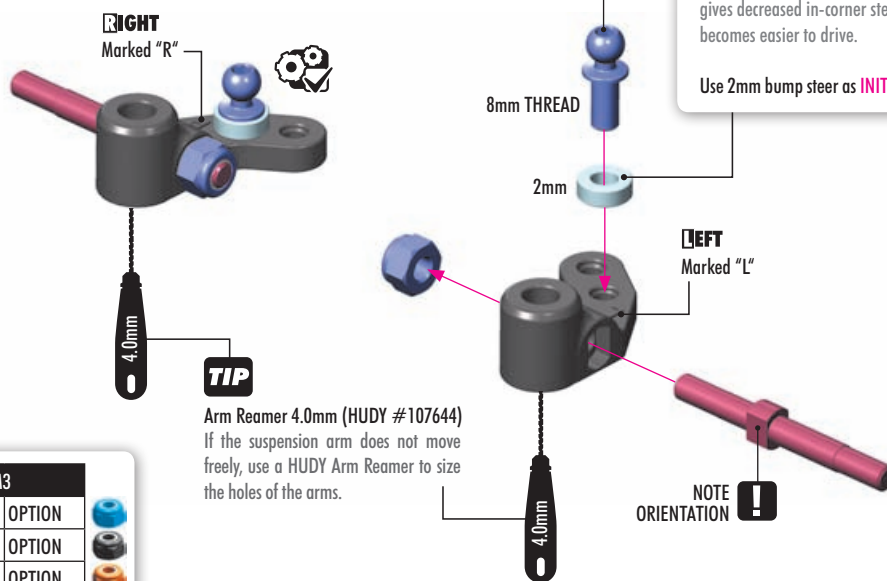

BUMPSTEER SETTING

The thickness of shims changes the steering linkage angle. Thicker shims gives decreased in-corner steering, but car becomes easier to drive.

Use 2mm bump steer as **INITIAL SETTING**.

TIP

Arm Reamer 4.0mm (HUDY #107644)
If the suspension arm does not move freely, use a HUDY Arm Reamer to size the holes of the arms.

NOTE ORIENTATION 

OPTION	ALU NUTS M3	
#296530-B	BLUE	OPTION
#296530-K	BLACK	OPTION
#296530-O	ORANGE	OPTION
#960031	SILVER	INCLUDED

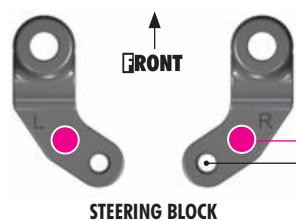

FORWARD POSITION (INITIAL SETTING)

Initial setting for most tracks provides a neutral steering feel similar to that of the old X12. Provides a good balance between initial response and cornering speed.

REARWARD POSITION

Makes the car freer because of increased Ackermann (less steering lock on the outer wheel in relation to the inner). Recommended for medium- to high-traction tracks.

TIP

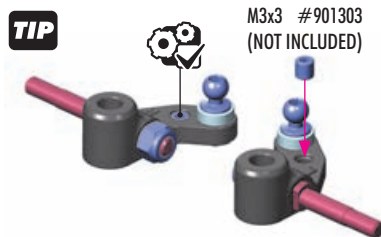

When using rearward hole, you can reinforce the steering block (for hard crashes) by installing an M3x3 setscrew in the forward hole.



960032
N M3

2x



NOTE ORIENTATION

The **DOT** must be oriented towards **OUTSIDE**.

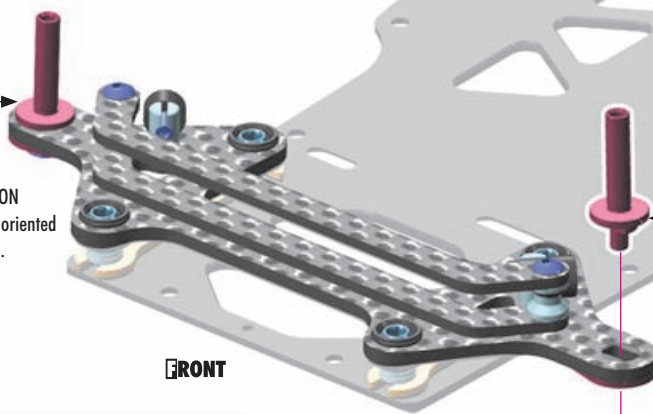

NOTE ORIENTATION

The **DOT** must be oriented towards **OUTSIDE**.



OPTION

CAMBER - KING PIN AXLE

#372285	0.5°	4 DOTS	OPTION	
#372282	1°	3 DOTS	INCLUDED	US
#372283	1.5°	1 DOT	INCLUDED	EU
#372284	2°	2 DOTS	OPTION	



CAMBER ADJUSTMENT

EU Edition kits include the 1.5° kingpins; US Edition kits include the 1.0° kingpins. These are the recommended start points for low to medium grip (EU) or high grip (US) conditions. Optional kingpins are available to adjust camber if needed.

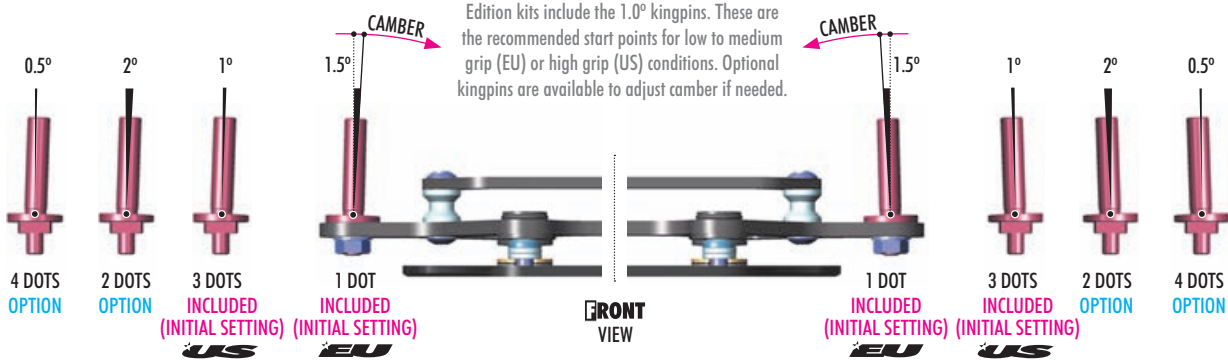

INCREASING THE CAMBER ANGLE

will increase the car steering, however, will make the car more difficult to drive.

DECREASING THE CAMBER ANGLE

will decrease the steering which will make the car easier to drive and also helps to prevent traction rolling.



903308
SFH M3x8



960031
ALU N M3

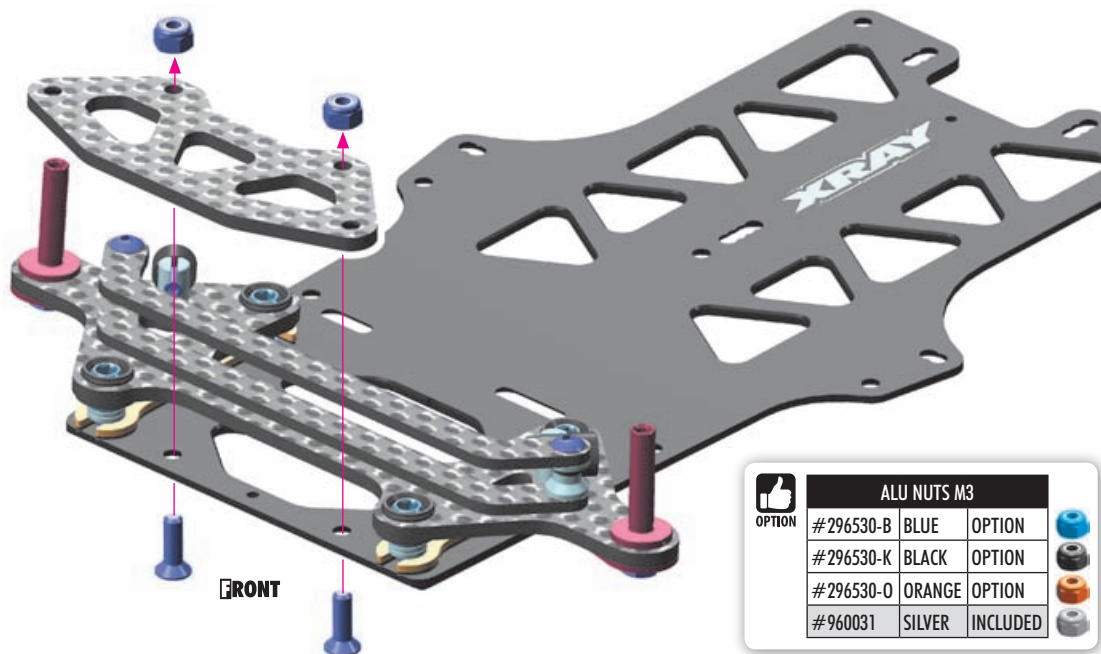

OPTION

ALU NUTS M3

#296530-B	BLUE	OPTION	
#296530-K	BLACK	OPTION	
#296530-O	ORANGE	OPTION	
#960031	SILVER	INCLUDED	



372297
SHIM 4x6x1



372298
SHIM 4x6x0.5



902305
SH M3x5



962042
S 4x6x0.1



962043
S 4x6x0.2



TIP

Alexander Hagberg
(Factory driver)

RIDE HEIGHT AND DROOP ADJUSTMENT SHIMS:

The ride height is adjusted with the supplied long shims that can be fitted under the arms (silver/black/gold). I recommend using as low of a ride height as you possibly can, unless you race on a bumpy or rough surface, then the car can benefit from having a slightly higher ride height, to increase stability, and improve the handling over bumps.

The front axle height can be adjusted with shims under the steering block. You can't change the roll center on the front end of the X12, simply because there is no upper arm. Adding shims under the steering block (raising the steering block) will raise the front axle height, and at the same time, decrease bump steer. Removing shims will lower the steering block, and increase bump steer. For more information about Ackermann & Bumpsteer, see PAGE 27 (servo mounting).

I recommend using the kit shimming for the front steering block - this will be a good basic setting for most conditions.

RIDE HEIGHT ADJUSTMENT

INITIAL SETTING

- above upper arm (0.3mm)
- below steering block (2.0mm)

FRONT DROOP

Front droop is adjusted by the preload of the front spring. More shims between the steering block and the spring will increase preload - and decrease droop. Removing shims will have the opposite effect.

MORE DROOP will make the car initially less responsive, but it will give the car more front grip, especially in the middle of the corner. The car will be less precise and more difficult to drive, because of increased roll. More droop is best suited for low- to medium-traction carpet, or asphalt.

LESS DROOP will decrease roll but the car will change direction quicker. Less droop is best suited for high-traction surfaces such as US black carpet, especially when traction rolling is an issue (and particularly when a rear solid axle is used).

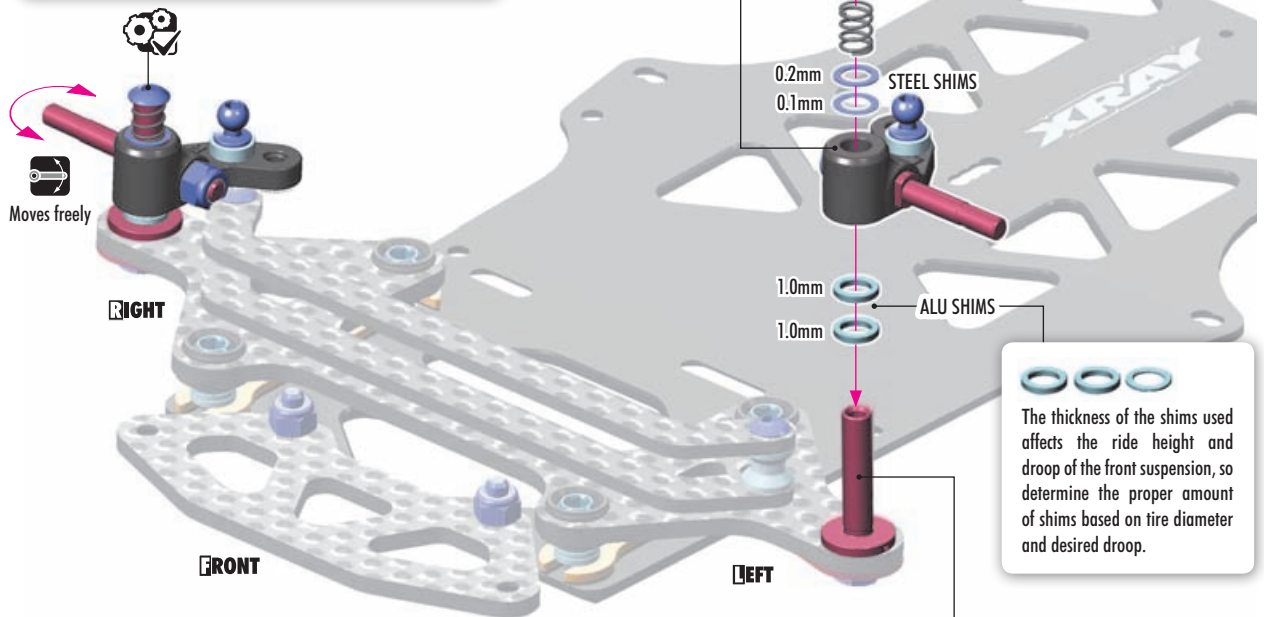

use HUDY Silicone Oil
10K cSt (INCLUDED)



VIDEO TECH TIP



FRONT KINGPIN OIL



FRONT COIL SPRINGS

OPTION	#	C	COLOR	OPTION
	#372186	C=1.5-1.7	GOLD	OPTION
	#372187	C=1.8-2.0	SILVER	INCLUDED
	#372188	C=2.1-2.3	BLACK	OPTION

SOFTER SPRINGS

Makes the car easier to drive over bumps and increases steering as it makes the car roll more, especially in the middle of a corner.

HARDER SPRINGS

Makes the car more responsive and increases initial steering. Recommended for high-traction and flat tracks.

TIP

Arm Reamer 4.0mm
(HUDY #107644)

The front suspension parts were updated to eliminate play to ensure better steering performance. The updated holes in the steering blocks may cause a tighter fit of the kingpin in the steering block; it is important that the steering block moves freely but without excessive play. If the kingpin does not insert into the steering block easily, use a 4mm Arm Reamer to enlarge the hole. Be very careful to remove only enough material so you can insert the kingpin without a lot of force.



LOW traction & bumpy track

7K ~ 10K cSt

HIGH traction & smooth track

15K ~ 30K cSt

FRONT DAMPING with different oils.

TRACK CONDITIONS

Thinner oil is recommended for low-traction tracks, while thicker oil is recommended for high-traction tracks.

DAMPING

Using thicker oil on the king pin axle makes the car less responsive but easier to drive. Thicker oil also increases stability but decreases cornering speed.



VIDEO TECH TIP



FRONT DROOP & RIDE HEIGHT

2. REAR SUSPENSION

EU US

#371164
GRAPHITE REAR POD LOWER PLATE

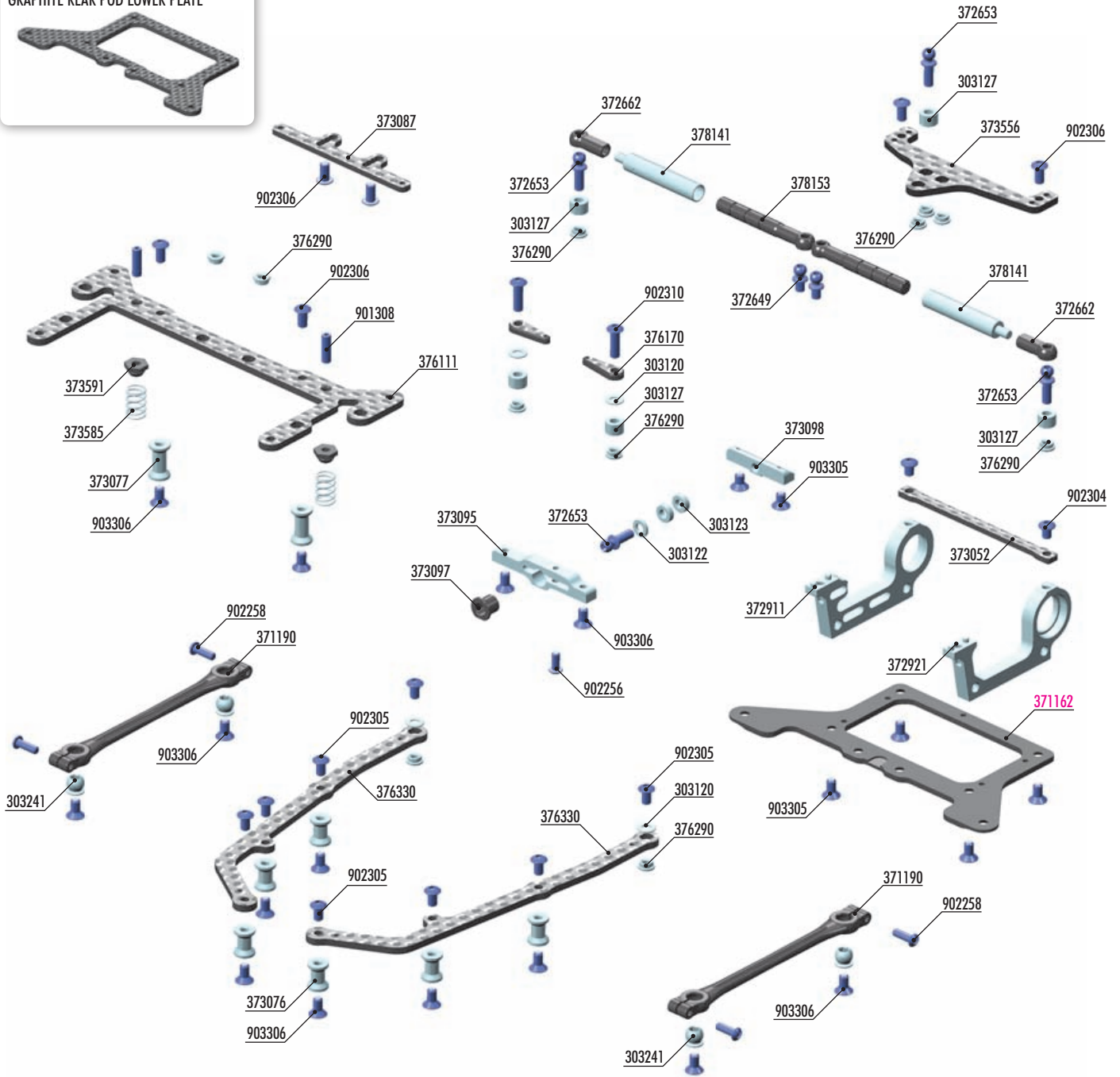

BAG

02

BUILD VIDEO



REAR SUSPENSION

303120 SET OF ALU SHIM (0.5MM, 1.5MM, 2.5MM)
 303122 ALU SHIM 3x6x1.0MM (10)
 303123 ALU SHIM 3x6x2.0MM (10)
 303127 ALU SHIM 3x6x4.0MM (10)
 303241 BALL UNIVERSAL 5.8 MM HEX (4)
 371190 COMPOSITE POD LINK (2)
 372649 BALL END 4.2MM WITH 4MM THREAD (2)
 372653 BALL END 4.2MM WITH 8MM THREAD (2)
 372662 COMPOSITE BALL JOINT 4.2 MM (4)
 372911 ALU REAR BULKHEAD - MOTOR - RIGHT
 372921 ALU REAR BULKHEAD - LEFT
 373052 GRAPHITE REAR BULKHEAD BRACE 2.2MM
 373076 ALU REAR BRACE MOUNT 9MM - BLACK (2)
 373077 ALU REAR BRACE MOUNT 12MM - BLACK (2)
 373087 GRAPHITE BATTERY BACKSTOP 2.2MM
 373095 ALU CHASSIS PIVOT HOLDER - SWISS 7075 T6
 373097 COMPOSITE PIVOT BRACE BUSHING
 373098 ALU POD PLATE PIVOT HOLDER - SWISS 7075 T6
 373556 GRAPHITE REAR POD UPPER PLATE 2.5MM
 373585 SIDE SPRING C=0.9 - GOLD (2)

373591 COMPOSITE SIDE SPRING HOLDER (2)
 376111 GRAPHITE REAR BRACE WITH BATTERY BACKSTOP 2.5MM
 376170 GRAPHITE BATTERY CLAMP 2.2MM (2)
 376290 LOW PROFILE ALU SELF-LOCKING NUT (2)
 376330 GRAPHITE SIDE BRACE 2.5MM - RIGHT & LEFT
 378141 ALU SIDE TUBE (2)
 378153 COMPOSITE SIDE TUBE SHAFT (2)
 901308 HEX SCREW SB M3x8 (10)
 902256 HEX SCREW SH M2.5x6 (10)
 902258 HEX SCREW SH M2.5x8 (10)
 902304 HEX SCREW SH M3x4 - STAINLESS (10)
 902305 HEX SCREW SH M3x5 (10)
 902306 HEX SCREW SH M3x6 (10)
 902310 HEX SCREW SH M3x10 (10)
 903305 HEX SCREW SFH M3x5 (10)
 903306 HEX SCREW SFH M3x6 (10)

371162 ALU 2.0MM REAR POD LOWER PLATE - 7075 T6

2. REAR SUSPENSION

★ EU ★ US



903305
SFH M3x5

▶ VIDEO TECH TIP



REAR POD & PIVOT
BUILD

NOTE
ORIENTATION

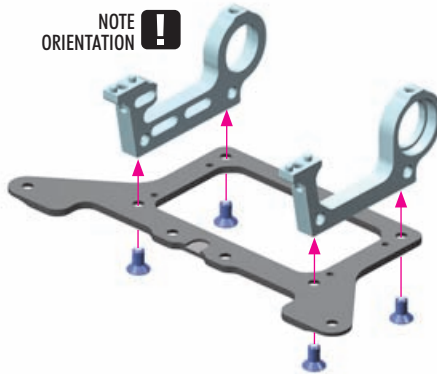

#371162
GRAPHITE REAR POD LOWER PLATE

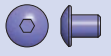

902304
SH M3x4

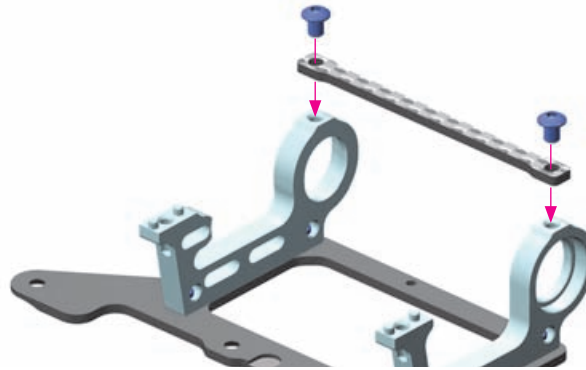

303122
SHIM 3x6x1



303123
SHIM 3x6x2



903305
SFH M3x5

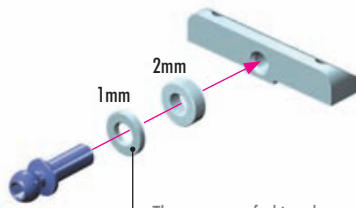

8mm THREAD

The amount of shims has a direct effect on the pivot mounting position.

Please see: PAGE 13
INITIAL SETTING - MIDDLE pivot mounting (1+2mm shim)

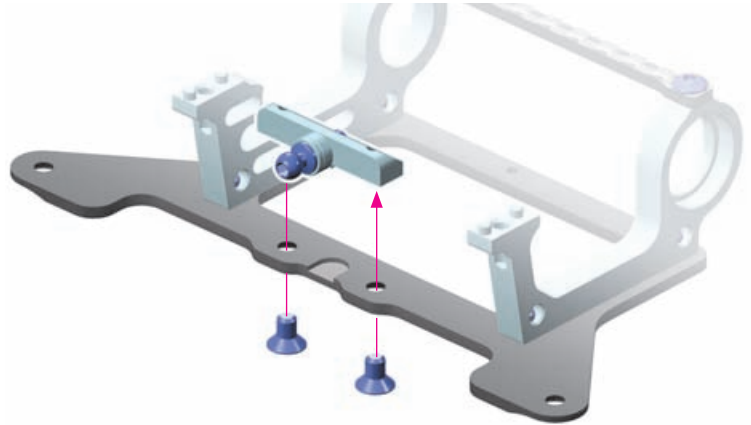

903306
SFH M3x6



▶ VIDEO TECH TIP



REAR POD & PIVOT
BUILD

NOTE ORIENTATION

NOTE ORIENTATION

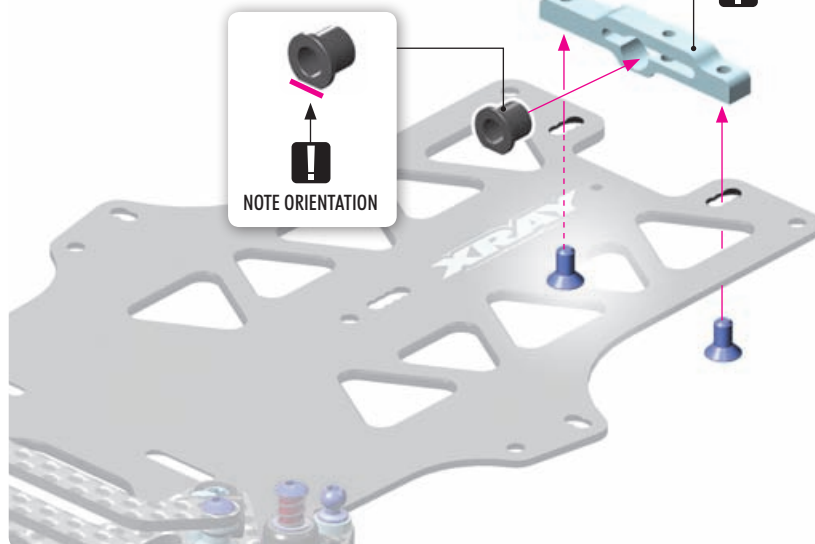

(INITIAL SETTING)

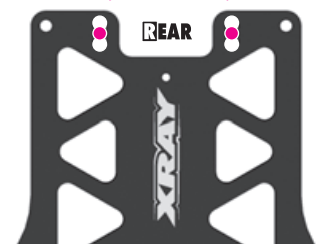

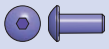

902256
SH M2.5x6



VIDEO TECH TIP



REAR POD & PIVOT BUILD

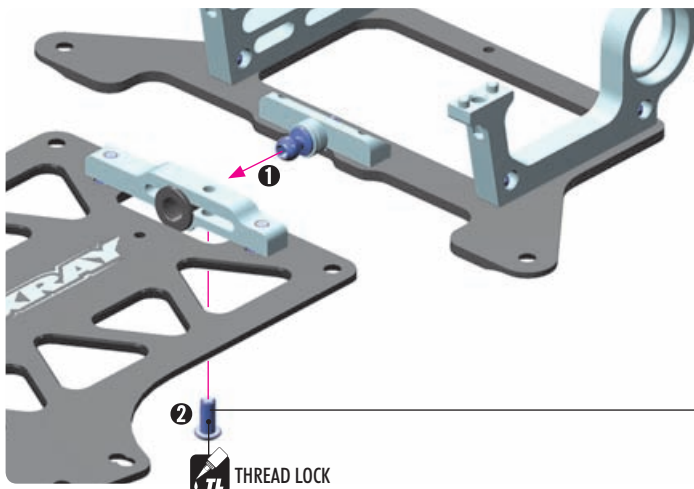

THREAD LOCK

Ensure free, smooth movement.



Tighten the screw enough to remove excess play, while ensuring that the pod plate can turn freely.

PIVOT MOUNTING ALTERNATIVE

REARWARD:

Pivot mounted in rearward chassis holes, and 1mm shim used under the pivot ball. The rearward pivot mounting gives the most neutral handling. Recommended for low to medium traction tracks.

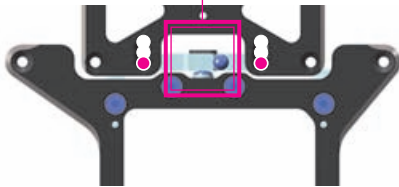

MIDDLE: (INITIAL SETTING)

Pivot mounted in middle chassis holes, with 3mm shims under the pivot ball. The middle pivot position gives a good balance between front and rear traction and is well suited for most conditions.

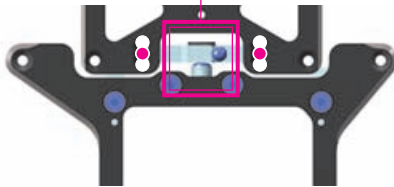

FORWARD:

Pivot mounted in forward chassis holes, with 5mm shims under the pivot ball. Improves rotation thanks to the longer rear pod geometry. Gives the most initial steering as well as rotation, especially suited for high traction conditions such as US black carpet.

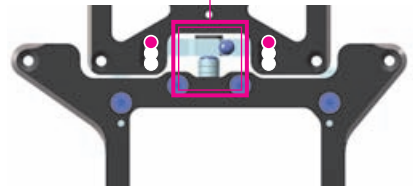

303122
SHIM 3x6x1



303123
SHIM 3x6x2



303122
SHIM 3x6x1



303123
SHIM 3x6x2

TIP #303122 & 303123 shims are NOT INCLUDED in the kit.

NOTE ORIENTATION

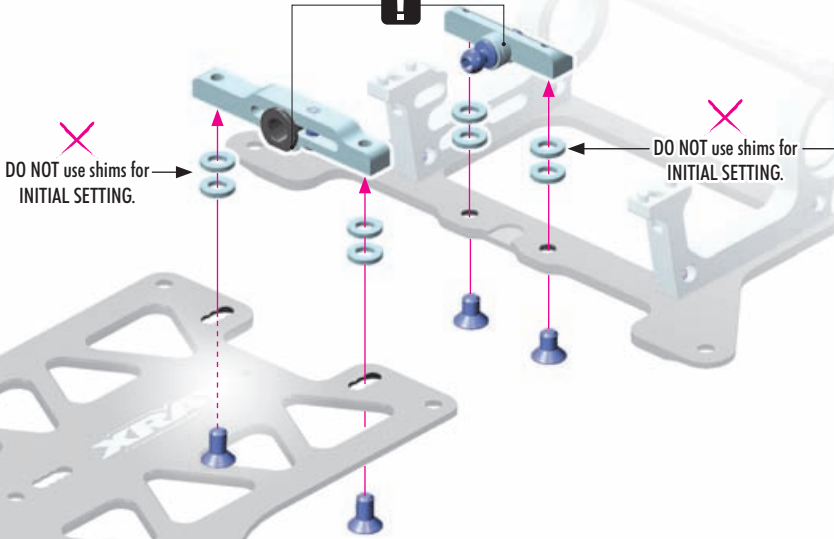

DO NOT use shims for INITIAL SETTING.

DO NOT use shims for INITIAL SETTING.

ROLL CENTER ADJUSTMENT

The roll center can be adjusted by adding or removing shims from beneath the aluminum pivot mounts.

LOWER ROLL CENTER

(INITIAL SETTING - NO SHIMS) will give more traction and increase chassis roll.

HIGHER ROLL CENTER

(adding shims) will increase steering by making the car rotate more on and off-power.



IMPORTANT! Always use same shim thickness on both sides of both aluminum holders.

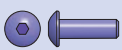

902258
SH M2.5x8

2x L=R

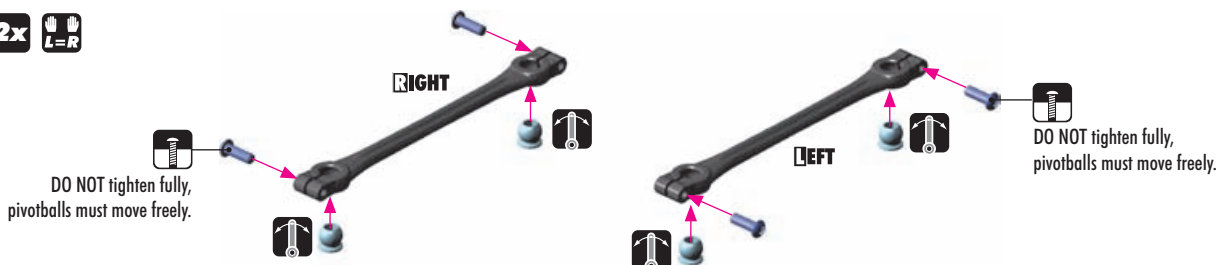

DO NOT tighten fully, pivotballs must move freely.

DO NOT tighten fully, pivotballs must move freely.

2. REAR SUSPENSION

★ EU ★ US



903306
SFH M3x6

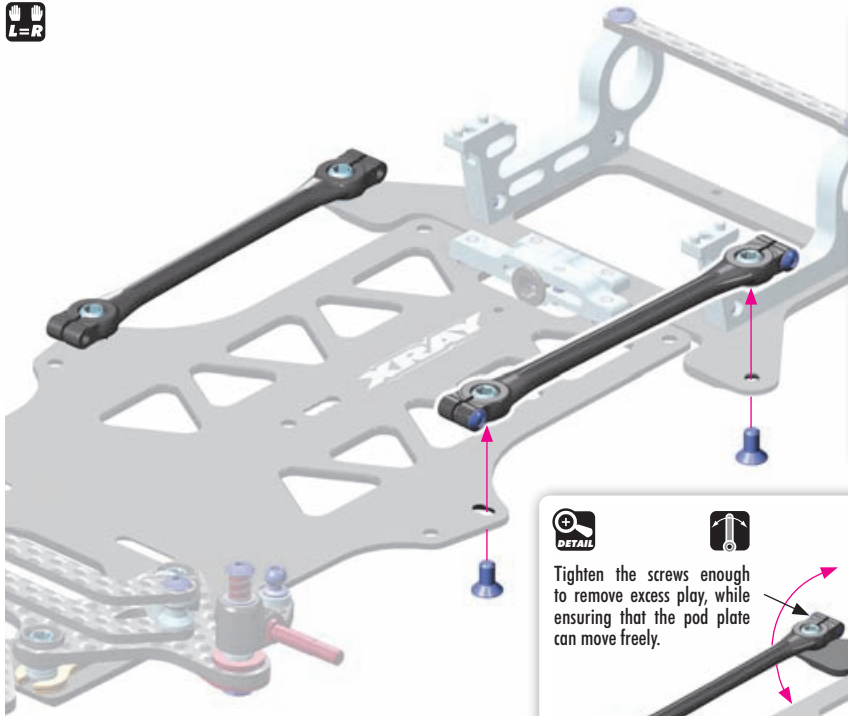

POD LINKAGE POSITION

OUTER POSITION - (INITIAL SETTING)

LESS ANGLED side links make the car easier to drive.

INNER POSITION

MORE ANGLED side links give increased in-corner steering.



Tighten the screws enough to remove excess play, while ensuring that the pod plate can move freely.

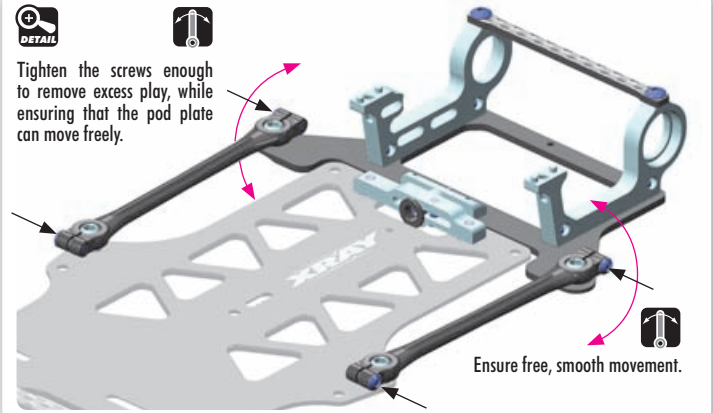

Ensure free, smooth movement.



303127
SHIM 3x6x4



901308
SB M3x8

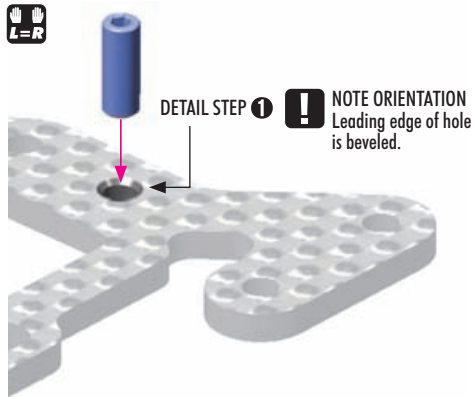

DETAIL STEP 1

! NOTE ORIENTATION
Leading edge of hole is beveled.

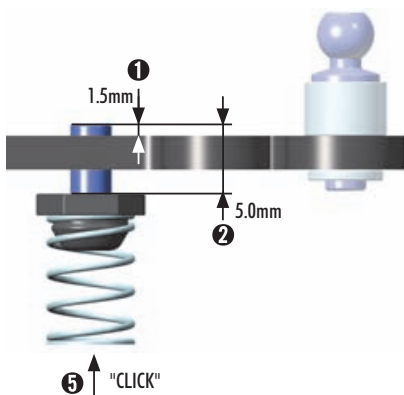

↑ "CLICK"

8mm THREAD

4mm

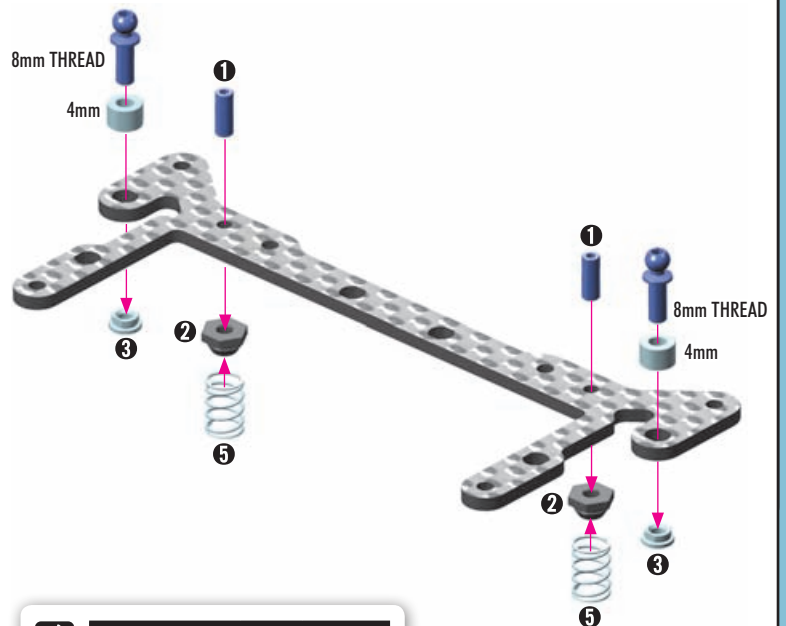

8mm THREAD

4mm



OPTION

SIDE SPRINGS

#373584	C=0.6	SILVER	OPTION
#373585	C=0.9	GOLD	INCLUDED
#373586	C=1.2	BLACK	OPTION
#373587	C=1.5	SILVER	OPTION
#373588	C=1.8	GOLD	OPTION



▶ VIDEO TECH TIP



TWEAK & SIDE SPRINGS SETTING

2. REAR SUSPENSION

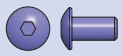

902306
SH M3x6



303120
SHIM 3x6x0.5



902310
SH M3x10



303127
SHIM 3x6x4



303120
SHIM 3x6x0.5

303127
SHIM 3x6x4

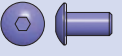
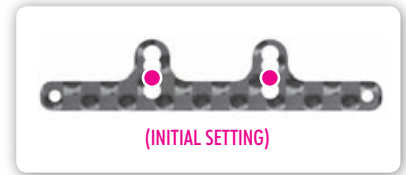
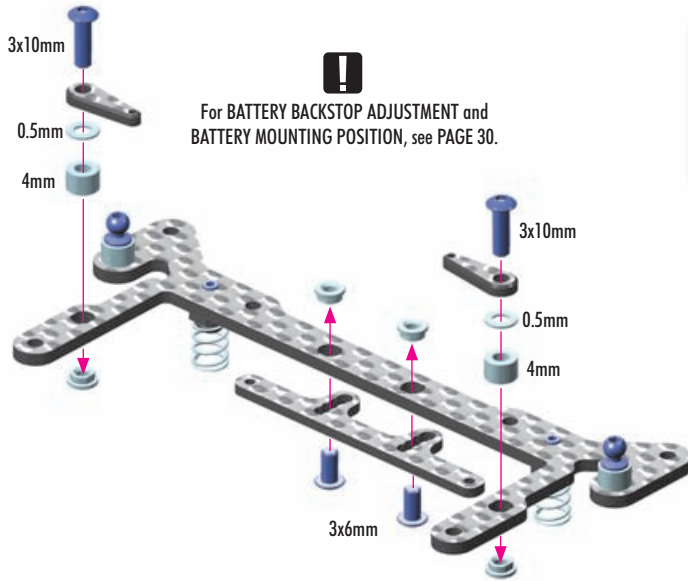

902306
SH M3x6

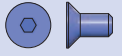

903306
SFH M3x6

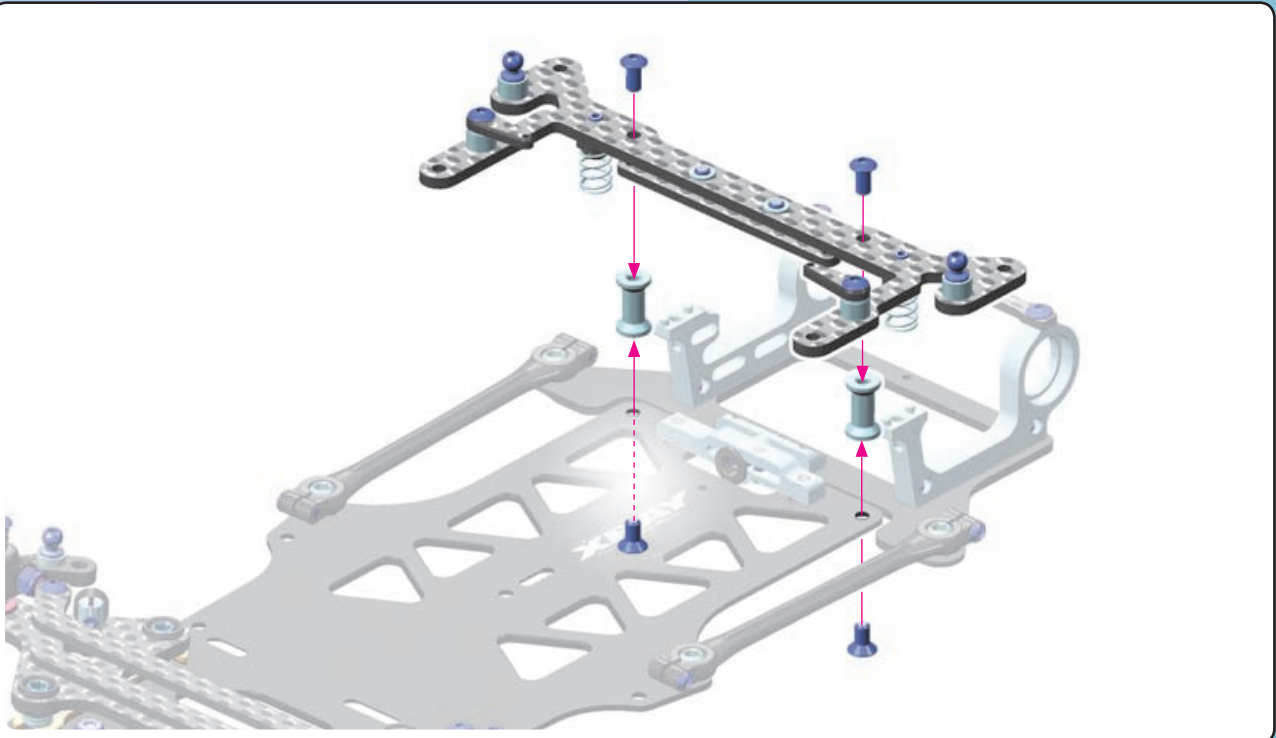

VIDEO TECH TIP



BATTERY MOUNTING SYSTEM



903306
SFH M3x6

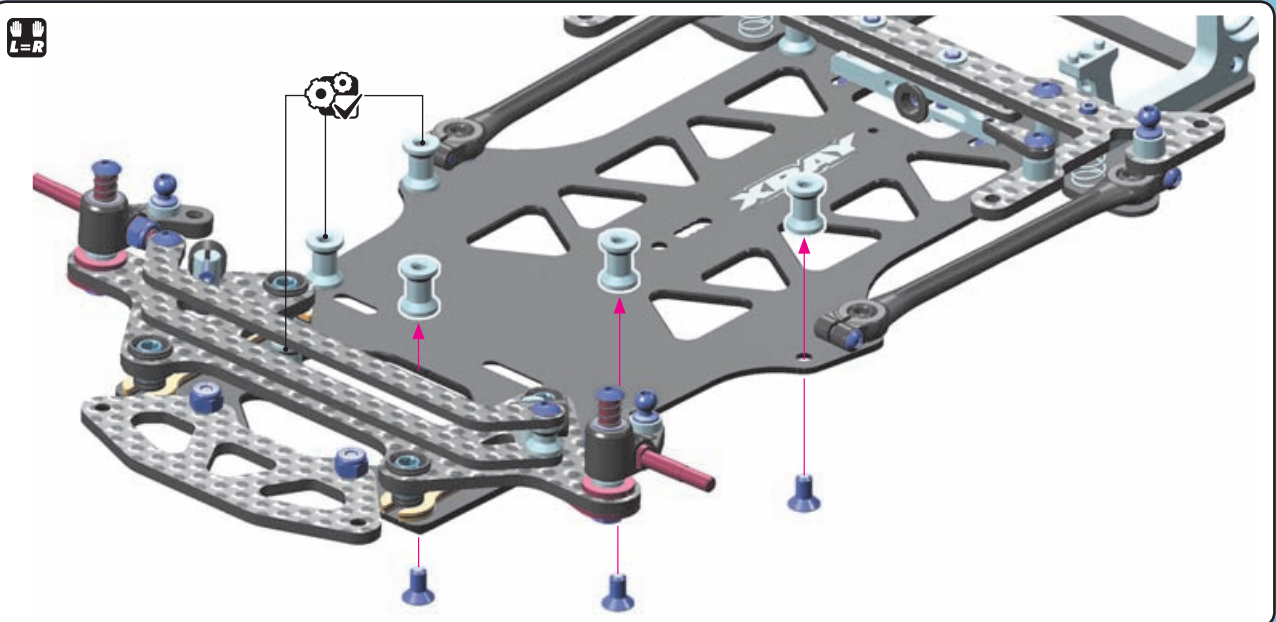



303120
SHIM 3x6x0.5



902305
SH M3x5



- STEP: Install the Graphite Braces.
- STEP: Tighten screws.

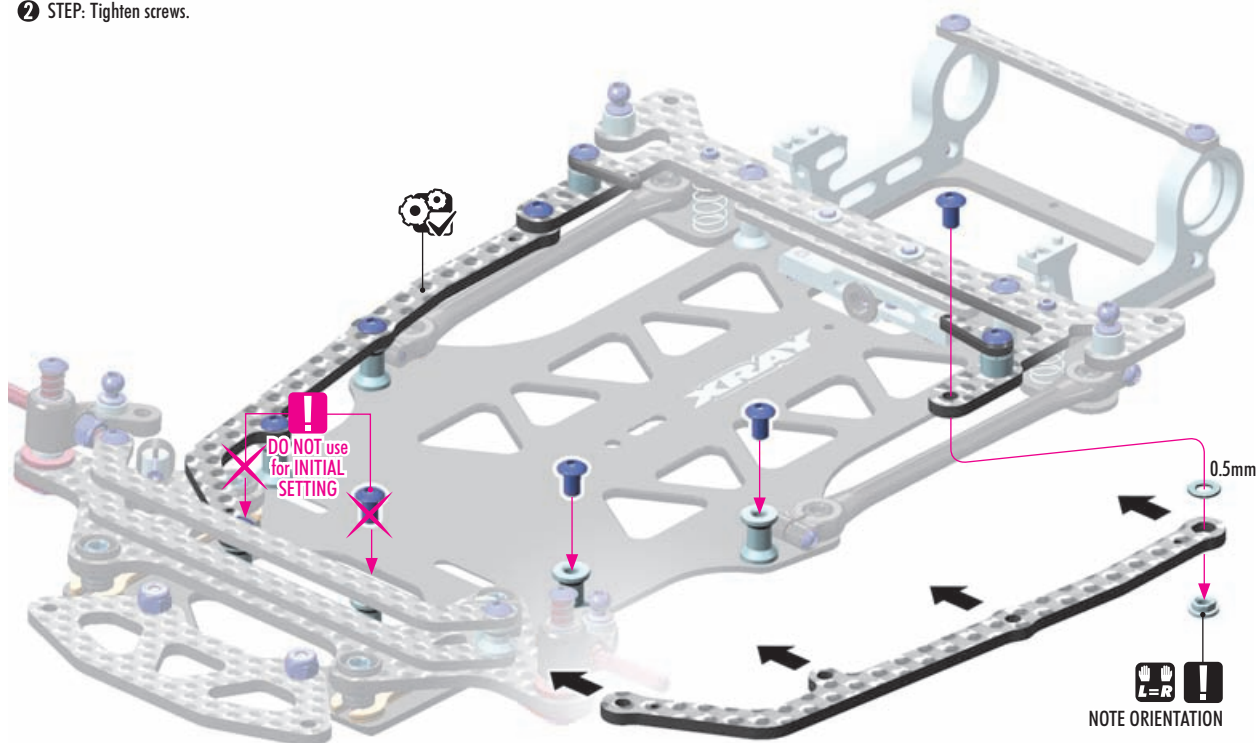

CHASSIS FLEX ADJUSTMENT

SOFT (NO BRACES)

Generates more mechanical grip. Recommended for low- to medium-traction carpet as well as asphalt.

MEDIUM

Braces installed, attached at middle & rear only. This setting is a good compromise between mechanical grip and steering response. Ideal for most conditions.

MEDIUM STIFF (INITIAL SETTING)

Braces installed, attached at middle-front, middle, and rear. A good compromise between mechanical grip, and steering response. A good option for higher grip conditions.

STIFF

Braces installed, attached at front, middle-front, middle and rear. This is the stiffest, most stable setting. Recommended for high-traction carpet (such as US black carpet). The car will have less roll but will also have less overall grip.

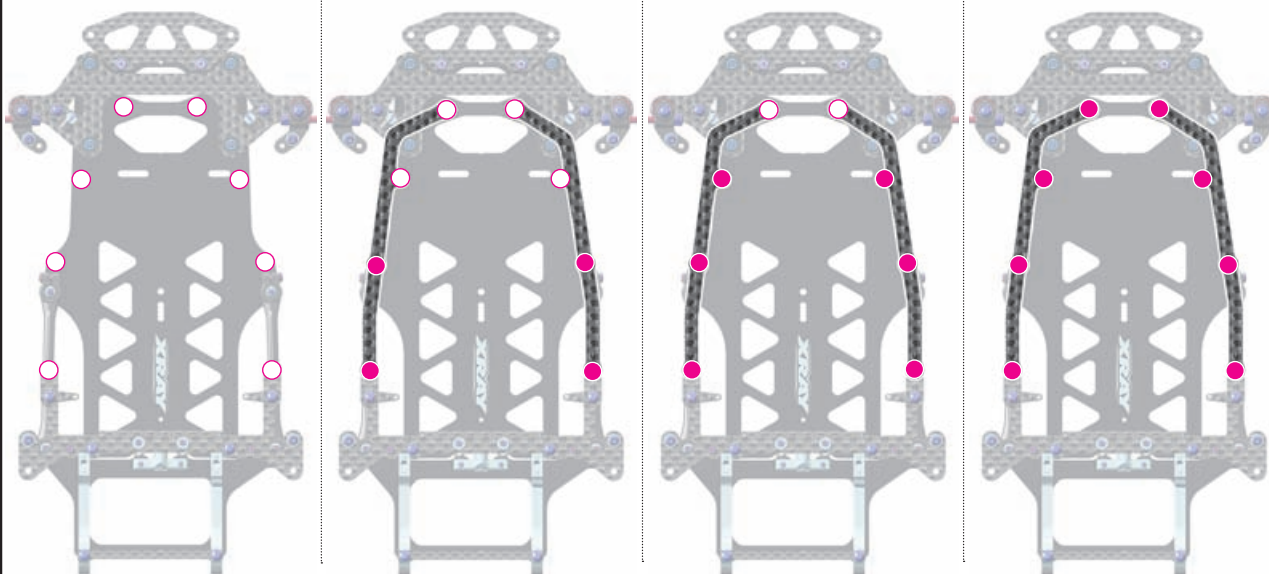

VIDEO TECH TIP



GRAPHITE SIDE BRACES



303127
SHIM 3x6x4

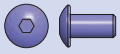
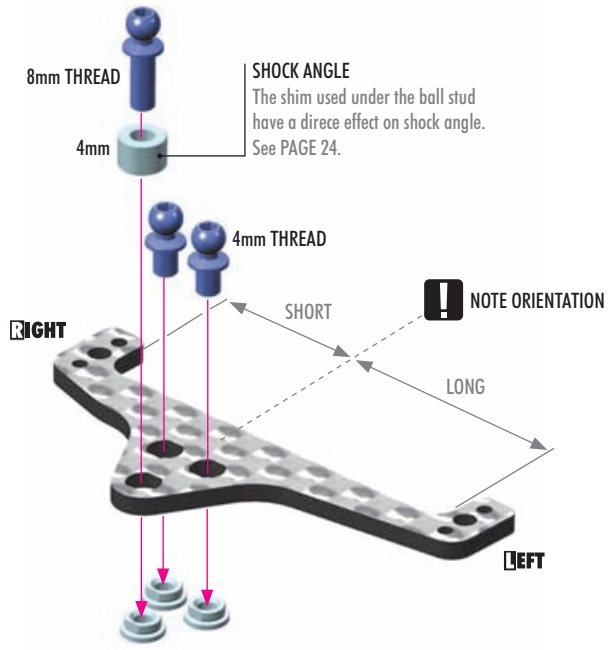

902306
SH M3x6



L=R

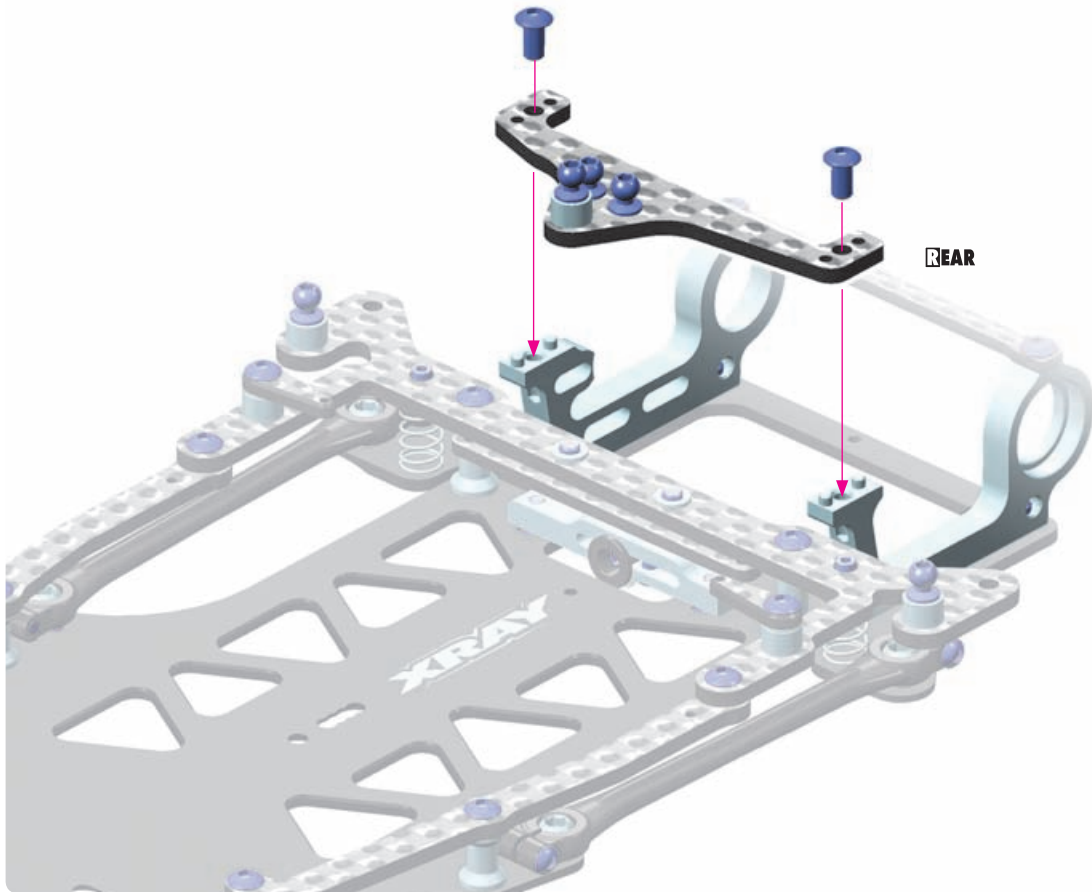

2. REAR SUSPENSION



VIDEO TECH TIP

SIDE TUBES

2x

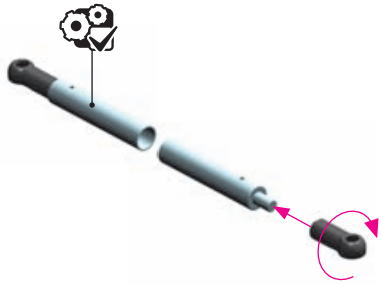

2x

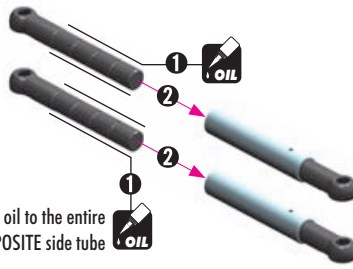

Apply oil to the entire COMPOSITE side tube

NOTE:

Apply oil to the entire composite side tube before installing in the aluminum tube. After assembly, check for smooth operation. It is very important to check and re-oil the tubes at least once per race day. Oil thickness can be adjusted depending on the track conditions.

TIP

For HIGH grip	use SOFTER oils
For LOW grip or ASPHALT	use HARDER oils



HUDY OILS 50ml

#106450	5.000cSt	
#106460	6.000cSt	
#106470	7.000cSt	
#106480	8.000cSt	
#106490	9.000cSt	
#106510	10.000cSt	INCLUDED
#106492	11.000cSt	
#106512	12.000cSt	
#106515	15.000cSt	
#106520	20.000cSt	
#106530	30.000cSt	



INCLUDED

L=R

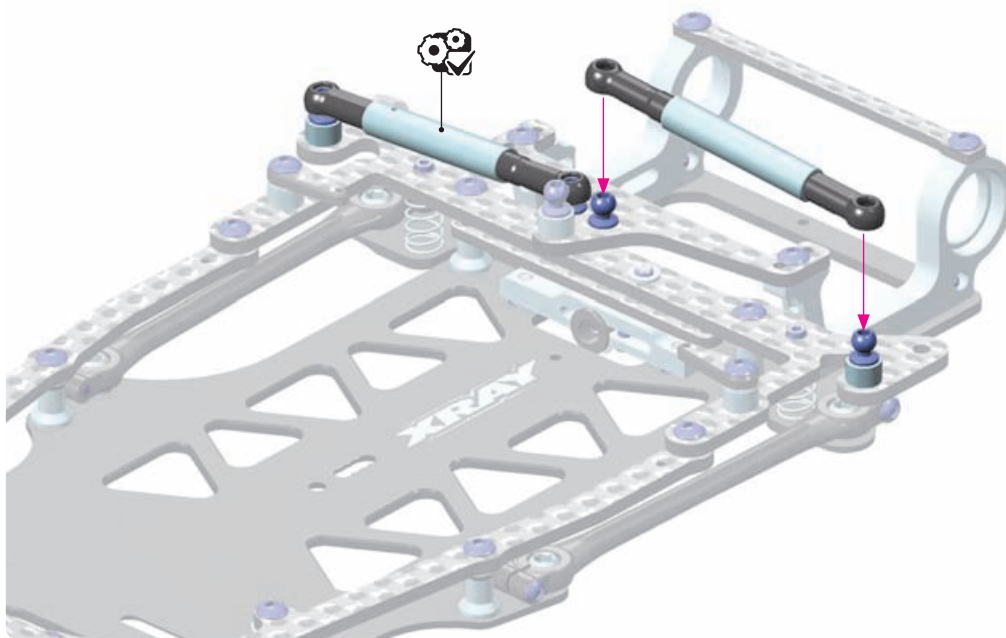

TIP SIDE TUBE ANGLE



The angle of the side tubes has a fine effect on car performance.

HIGHER ANGLE:
Stiffer feeling, less roll.

LOWER ANGLE (FLATTER):
Softer feeling, more roll.



3. SOLID AXLE

EU US

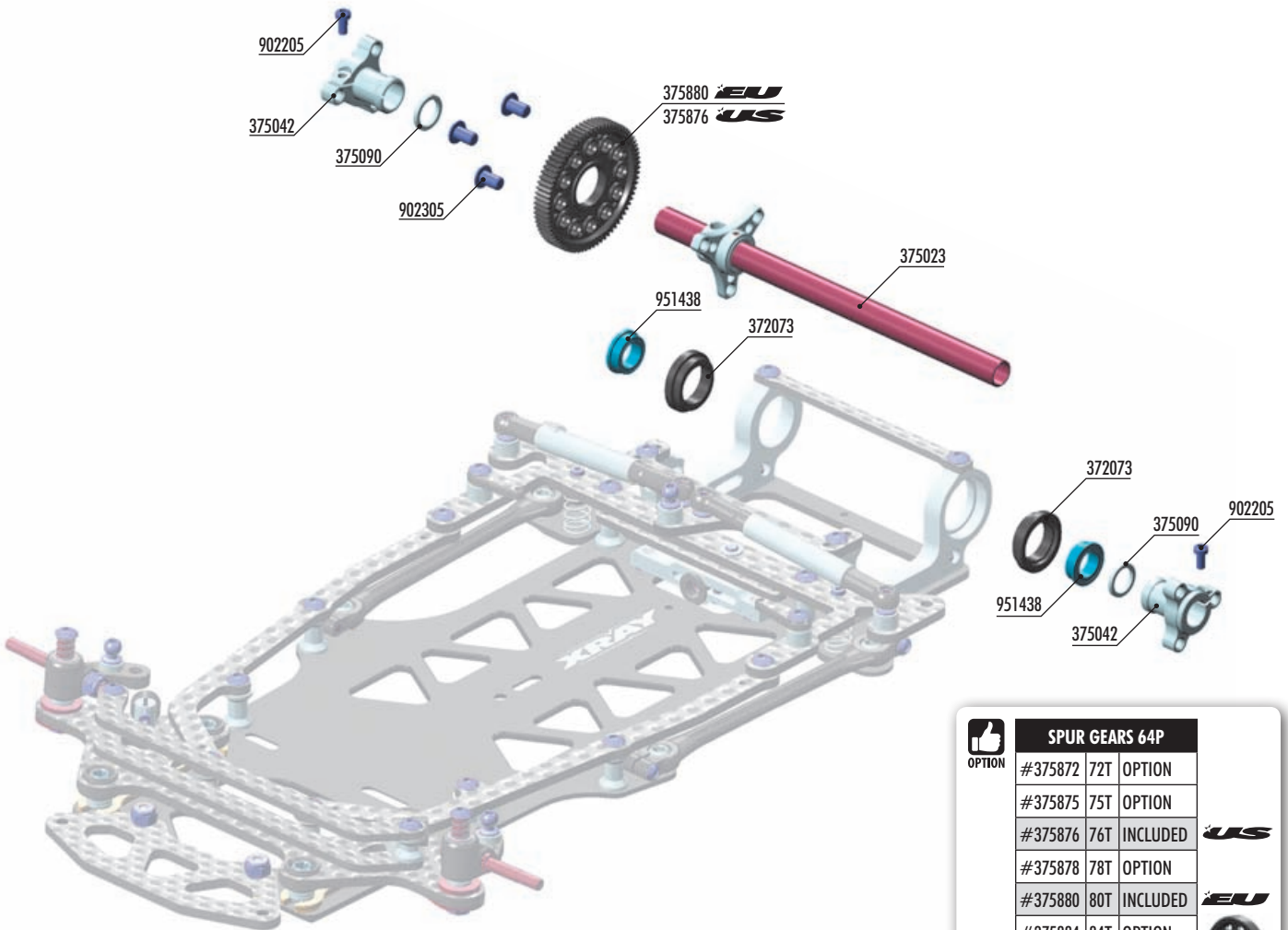

OPTION	SPUR GEARS 64P		
#375872	72T	OPTION	
#375875	75T	OPTION	
#375876	76T	INCLUDED	US
#375878	78T	OPTION	
#375880	80T	INCLUDED	EU
#375884	84T	OPTION	
#375888	88T	OPTION	
#375892	92T	OPTION	

#374900
XRAY GEAR DIFFERENTIAL
1/12 PAN CAR - SET

OPTION

Included in set #374900

GEAR DIFF - SPUR GEARS		
#375776	76T / 64P	OPTION
#375780	80T / 64P	OPTION
#375784	84T / 64P	OPTION
#375788	88T / 64P	OPTION
#375792	92T / 64P	OPTION

#375009
X12 BALL DIFFERENTIAL - SET

OPTION

#930238
CERAMIC BALL-BEARING AXIAL F3-8 3x8x3.5

OPTION

#930230
XRAY CERAMIC BALL 3.175MM (12)

OPTION

VIDEO TECH TIP

BALL DIFFERENTIAL

- BAG 03**
- BUILD VIDEO**
- SOLID AXLE**
- 372073 COMPOSITE ECCENTRIC RIDE HEIGHT ADJUSTER SET (2)
 - 375023 REAR SOLID AXLE SHAFT - SHORTER - LIGHTWEIGHT - HUDY SPRING STEEL™
 - 375042 ALU REAR ONE-PIECE WHEEL HUB - LIGHTWEIGHT
 - 375090 SET OF ALU SHIMS (0.5MM, 1.0MM, 2.0MM)
 - 375876 COMPOSITE SPUR GEAR - 76T / 64P
 - 375880 COMPOSITE SPUR GEAR - 80T / 64P
 - 902205 HEX SCREW SH M2x5 (10)
 - 902305 HEX SCREW SH M3x5 (10)
 - 951438 BALL-BEARING 1/4" x 3/8" x 1/8" FLANGED - STEEL SEALED - OIL (2)

3. SOLID AXLE

EU **US**



951438
BB 1/4"x3/8"x1/8"

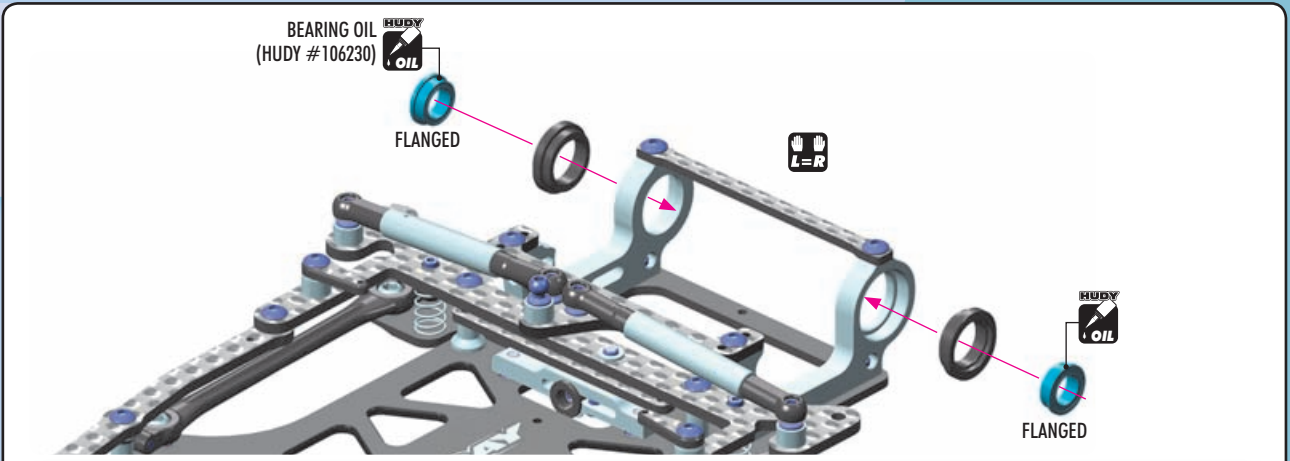

These eccentric bushings adjust the **RIDE HEIGHT** of the rear pod. Make sure to use the **SAME** eccentric bushings on **BOTH** sides.

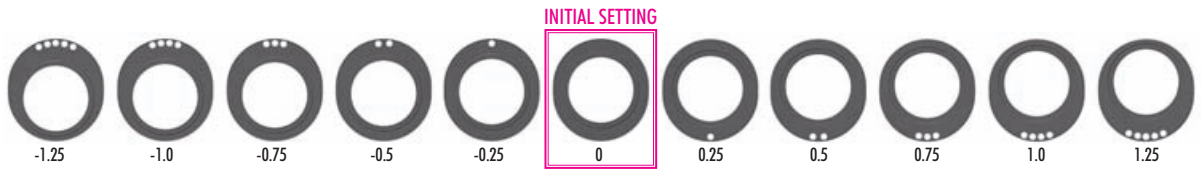

375090
6.4x8.4x1.0



375090
6.4x8.4x0.5



902205
SH M2x5

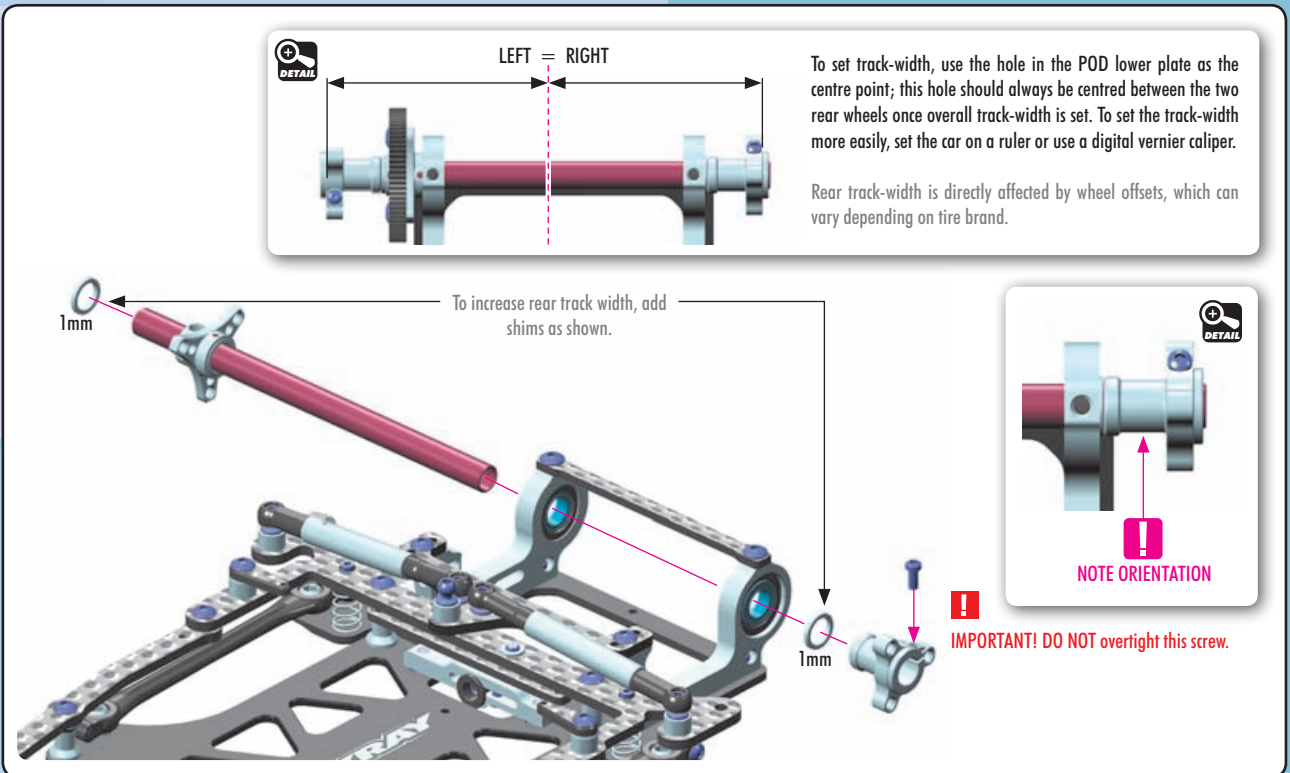

902205
SH M2x5



902305
SH M3x5

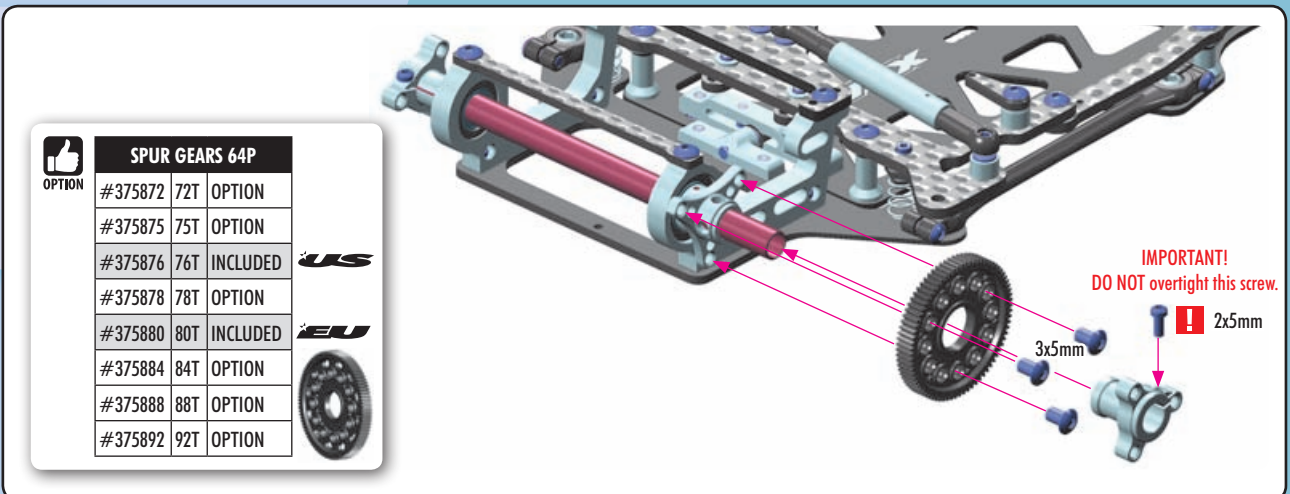

SPUR GEARS 64P			
OPTION	#375872	72T	OPTION
	#375875	75T	OPTION
	#375876	76T	INCLUDED US
	#375878	78T	OPTION
	#375880	80T	INCLUDED EU
	#375884	84T	OPTION
	#375888	88T	OPTION
	#375892	92T	OPTION

4. SHOCK ABSORBER

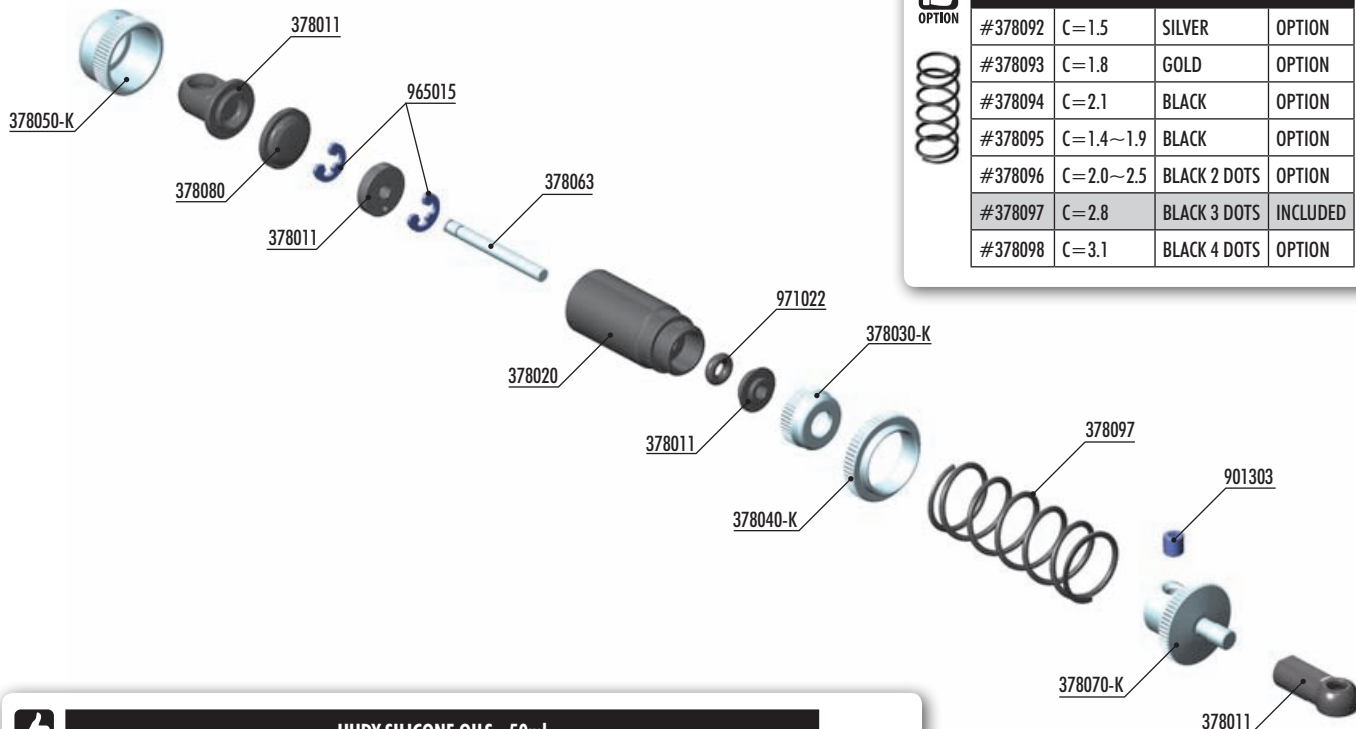

SHOCK SPRINGS			
#378092	C=1.5	SILVER	OPTION
#378093	C=1.8	GOLD	OPTION
#378094	C=2.1	BLACK	OPTION
#378095	C=1.4~1.9	BLACK	OPTION
#378096	C=2.0~2.5	BLACK 2 DOTS	OPTION
#378097	C=2.8	BLACK 3 DOTS	INCLUDED
#378098	C=3.1	BLACK 4 DOTS	OPTION

HUDY SILICONE OILS - 50ml								
#106310	100cSt	OPTION	#106342	425cSt	OPTION	#106365	650cSt	OPTION
#106315	150cSt	OPTION	#106345	450cSt	INCLUDED	#106367	675cSt	OPTION
#106320	200cSt	OPTION	#106347	475cSt	OPTION	#106370	700cSt	OPTION
#106325	250cSt	OPTION	#106350	500cSt	OPTION	#106375	750cSt	OPTION
#106330	300cSt	OPTION	#106355	550cSt	OPTION	#106380	800cSt	OPTION
#106335	350cSt	OPTION	#106357	575cSt	OPTION	#106390	900cSt	OPTION
#106337	375cSt	OPTION	#106360	600cSt	OPTION	#106410	1000cSt	OPTION
#106340	400cSt	OPTION	#106362	625cSt	OPTION	#106420	2000cSt	OPTION



BAG

04

- 378002 SHOCK ABSORBER SET - BLACK
- 378011 COMPOSITE SHOCK PARTS - FRAME
- 378020 ALU THREADED SHOCK BODY - HARDCOATED
- 378030-K ALU SHOCK BODY CAP - LOWER - BLACK
- 378040-K ALU SHOCK ADJUSTABLE COLLAR - BLACK
- 378050-K ALU SHOCK BODY CAP - UPPER - BLACK
- 378063 SHOCK SHAFT 24MM
- 378070-K ALU SHOCK SPRING COLLAR - BLACK
- 378080 SHOCK RUBBER MEMBRANE (2)
- 378097 SHOCK SPRING C=2.8 - BLACK - 3 DOTS

- 901303 HEX SCREW SB M3x3 (10)
- 965015 E-CLIP 1.5 (10)
- 971022 SILICONE O-RING 2x2 (10)

BUILD VIDEO

SHOCK ABSORBER



965015
C1.5

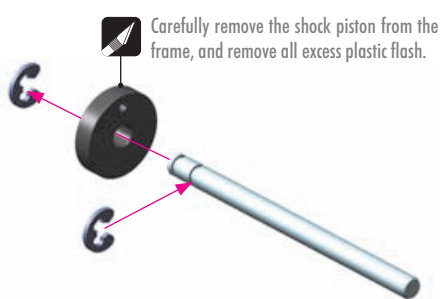

4. SHOCK ABSORBER

★ EU

★ US

OI

971022
0 2x2

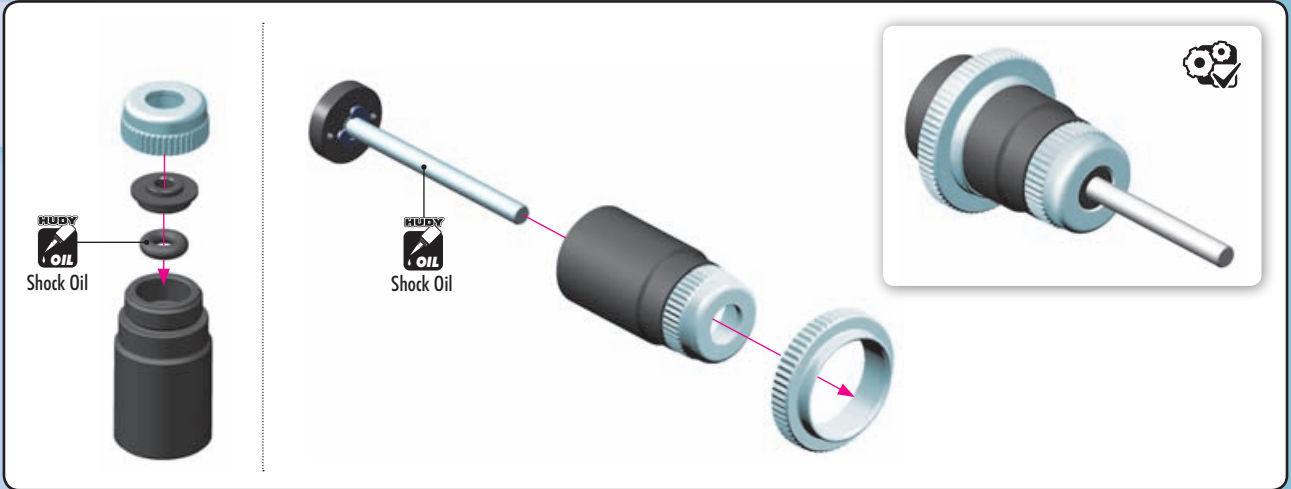

DEFAULT SHOCK SETTING FOR SHOCK ABSORBER

Follow the steps below to set the shock.

1

Extend the shock shaft completely. Fill the shock body with the shock oil.

2

Move the shock shaft up and down a few times to release the air bubbles trapped beneath the piston.

3~5x UP & DOWN

3

Orient the filled shock vertically for several minutes with the shock shaft fully extended. The remaining air bubbles will release.

4

Install the shock membrane into the groove in the upper shock cap.

5

HALF TIGHTEN 50%

Gently place the shock cap assembly onto the filled shock body. Excess oil will spill from the shock. Screw the shock cap onto the body by only a few turns, approx. 50%. Excess oil will flow through the hole in the shock cap.

6

TIGHTEN FULLY 100%

Gently push the shock shaft completely into the shock body. Excess oil will flow through the hole in the shock cap.

7

Keep the shock shaft pushed in the shock body and tighten the shock cap completely.

Tighten the cap fully but do not overtighten or the rubber membrane may be damaged. Make sure that there is no oil leakage after the cap is tightened.

▶ VIDEO TECH TIP

HOW TO BUILD CENTER SHOCK

901303 SB M3x3

5mm

For initial setting, thread fully.

Press the collar FULLY onto the end of the shock shaft and tighten the M3x3 setscrew.

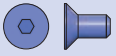

903306
SFH M3x6

DROOP ADJUSTMENT

The overall length of the shock absorber affects the amount of droop. To adjust, thread the ball-joint on or off the bottom spring cap or adapter.

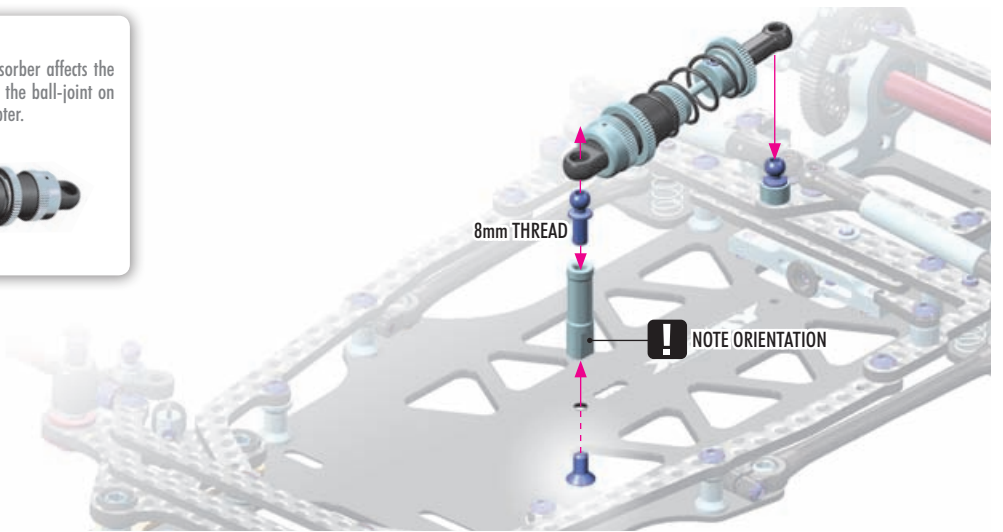
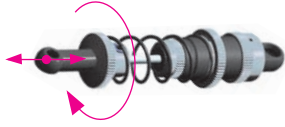

SHOCK ANGLE & POSITION

MORE SHOCK ANGLE

Less shim in front, more shim in rear.

Makes the damping more progressive and increases on-power steering. Recommended for high-traction conditions when you need to free up the rear.

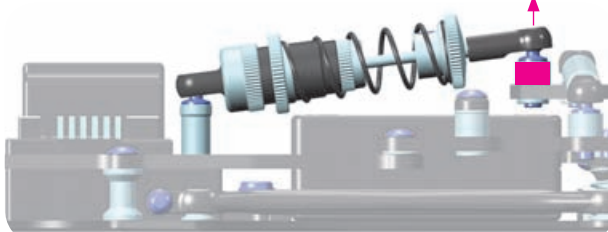

LESS SHOCK ANGLE

More shim in front, less shim in rear.

Makes the damping more linear. Increases stability, decreases on-power steering. Recommended for low- to medium-traction conditions.

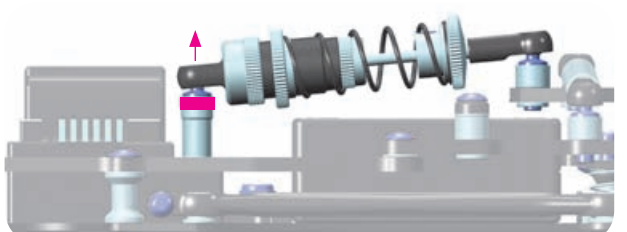

VIDEO TECH TIP



POD DROOP & RIDE HEIGHT

FORWARD BATTERY POSITION

When the forward battery position is used, make sure that the shock absorber is not touching the battery. Check also when the rear POD is lifted. If the shock is touching, use the same amount of shims under both ball ends on the shock absorber.

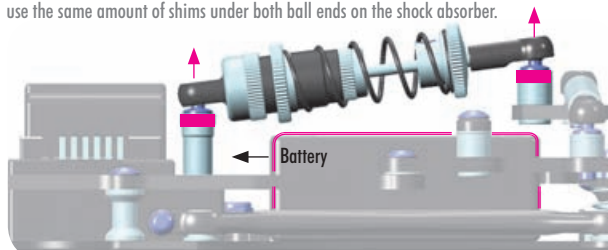

REARWARD BATTERY POSITION

When the rearward battery position is used, the shock can be placed lower to decrease the CG as much as possible. Make sure that the shock absorber is not touching the battery. Check also when the rear POD is lifted.

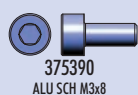
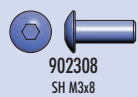
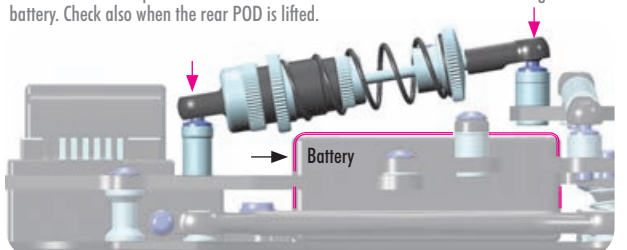

INITIAL SETTING (MINI servo)

VIDEO TECH TIP



INITIAL SETTING (MICRO servo)

MINI Servo (NOT INCLUDED)
(Examples: KO Propo, Futaba, Savox, Power HD)

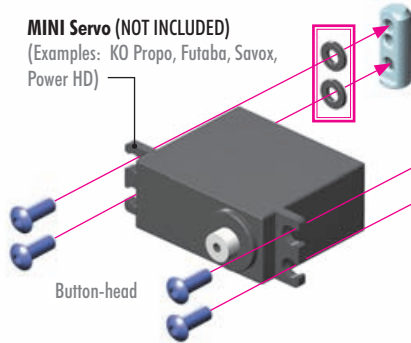

See PAGE 27 for more information about Ackermann settings.

NOTE ORIENTATION

6mm shim

MINI SERVO POSITION



MICRO Servo (NOT INCLUDED)
(Example: Sanwa)

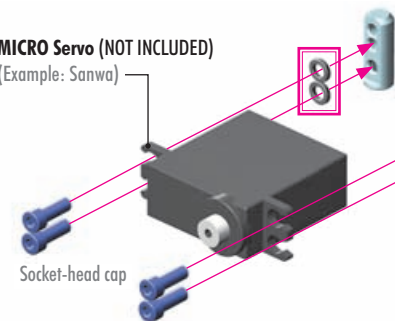

See PAGE 27 for more information about Ackermann settings.

NOTE ORIENTATION

5mm shims

MICRO SERVO POSITION



SERVO SAVER

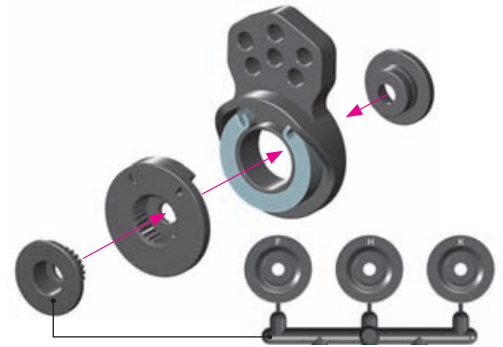
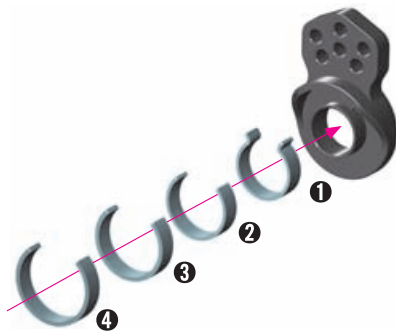

F = 25T H = 24T K = 23T
 ! Use the adapter that matches the steering servo.

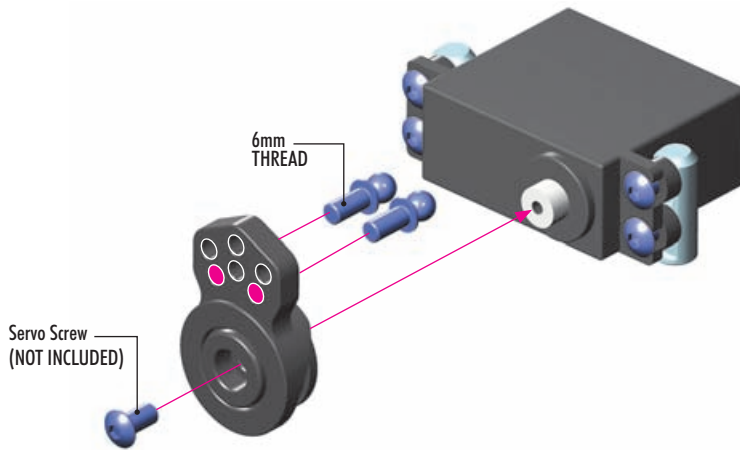

Note the orientation of servo saver when servo is in neutral. **INITIAL SETTING**

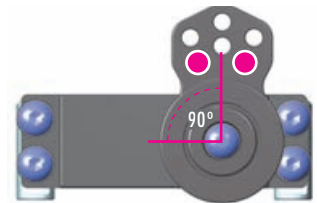

902304
SH M3x4



Make sure to center the servo saver along the chassis centerline.

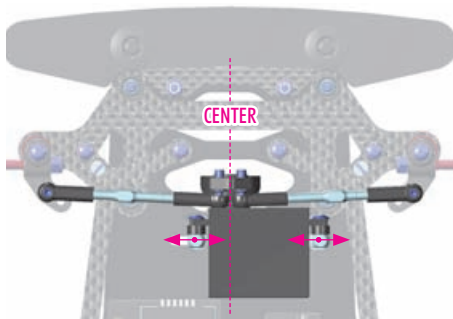

TOP VIEW

To better see the chassis centerline, there is a small mark on the chassis.

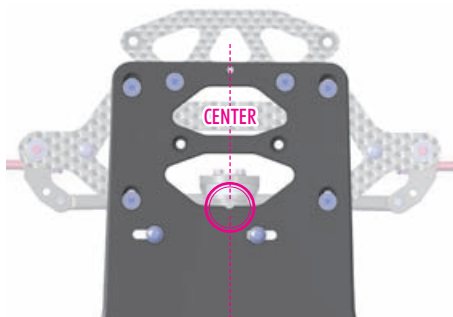

BOTTOM VIEW

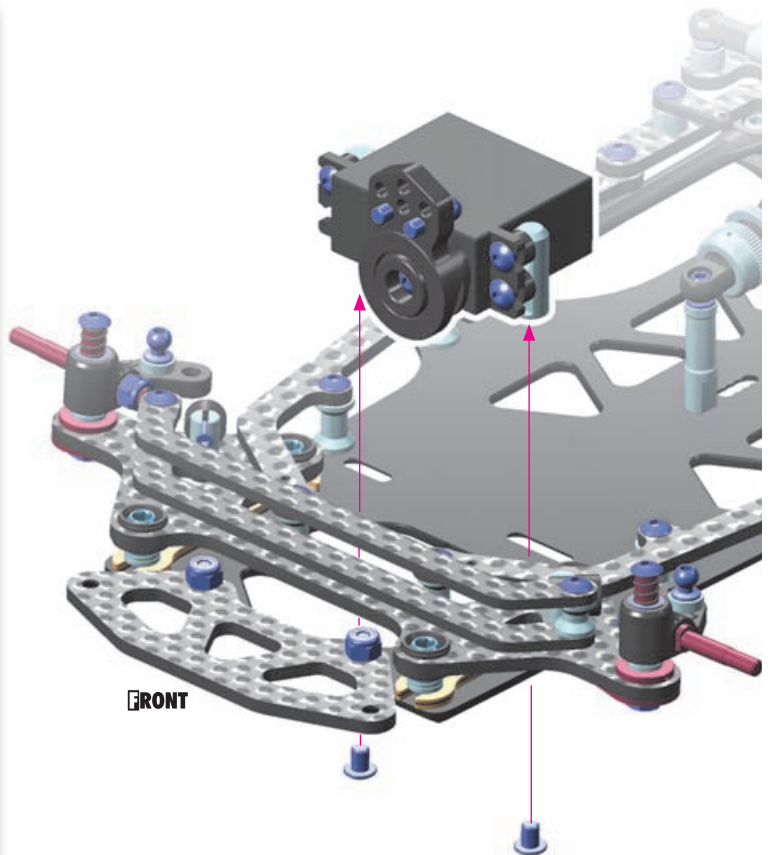

FRONT

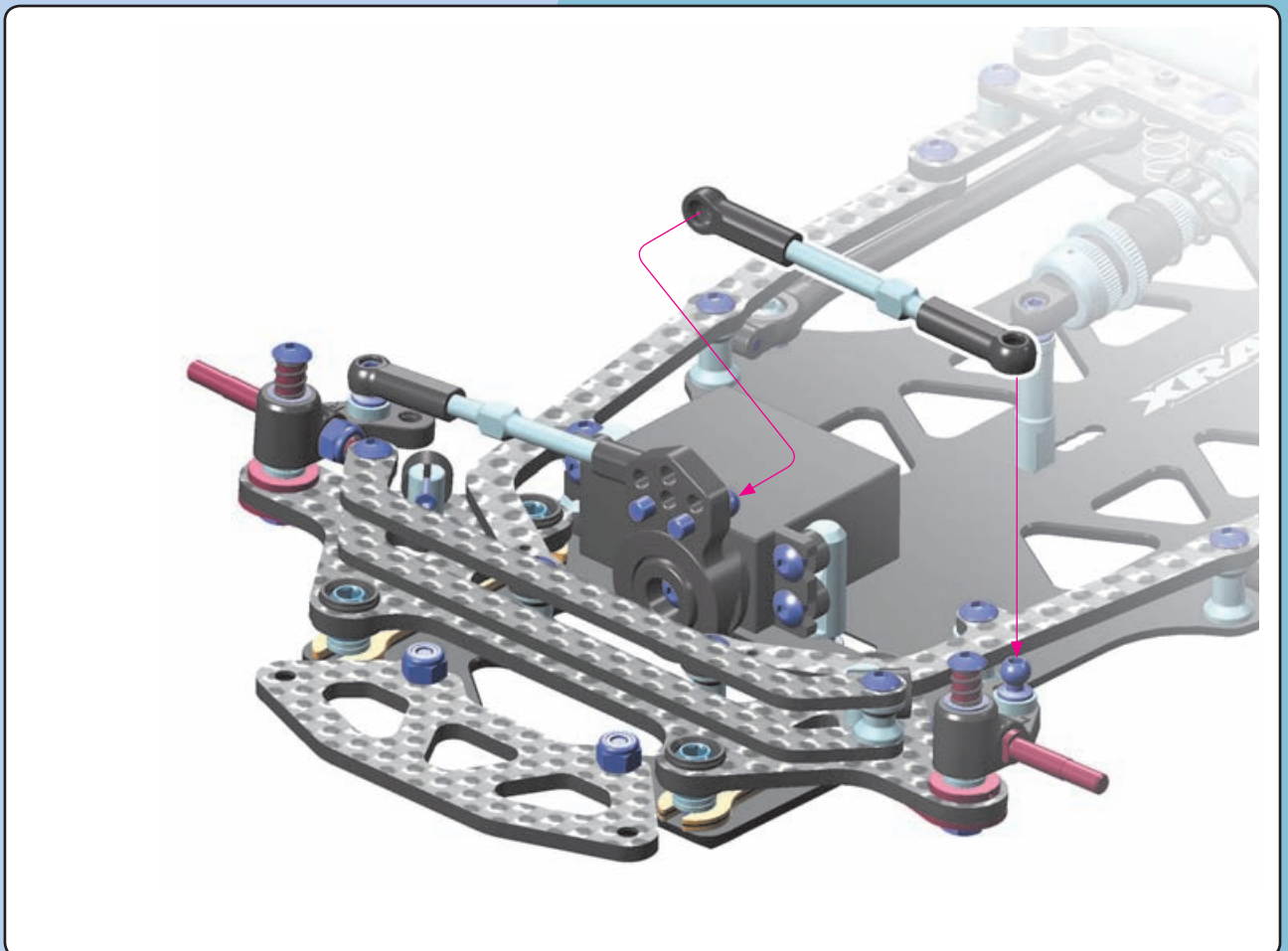
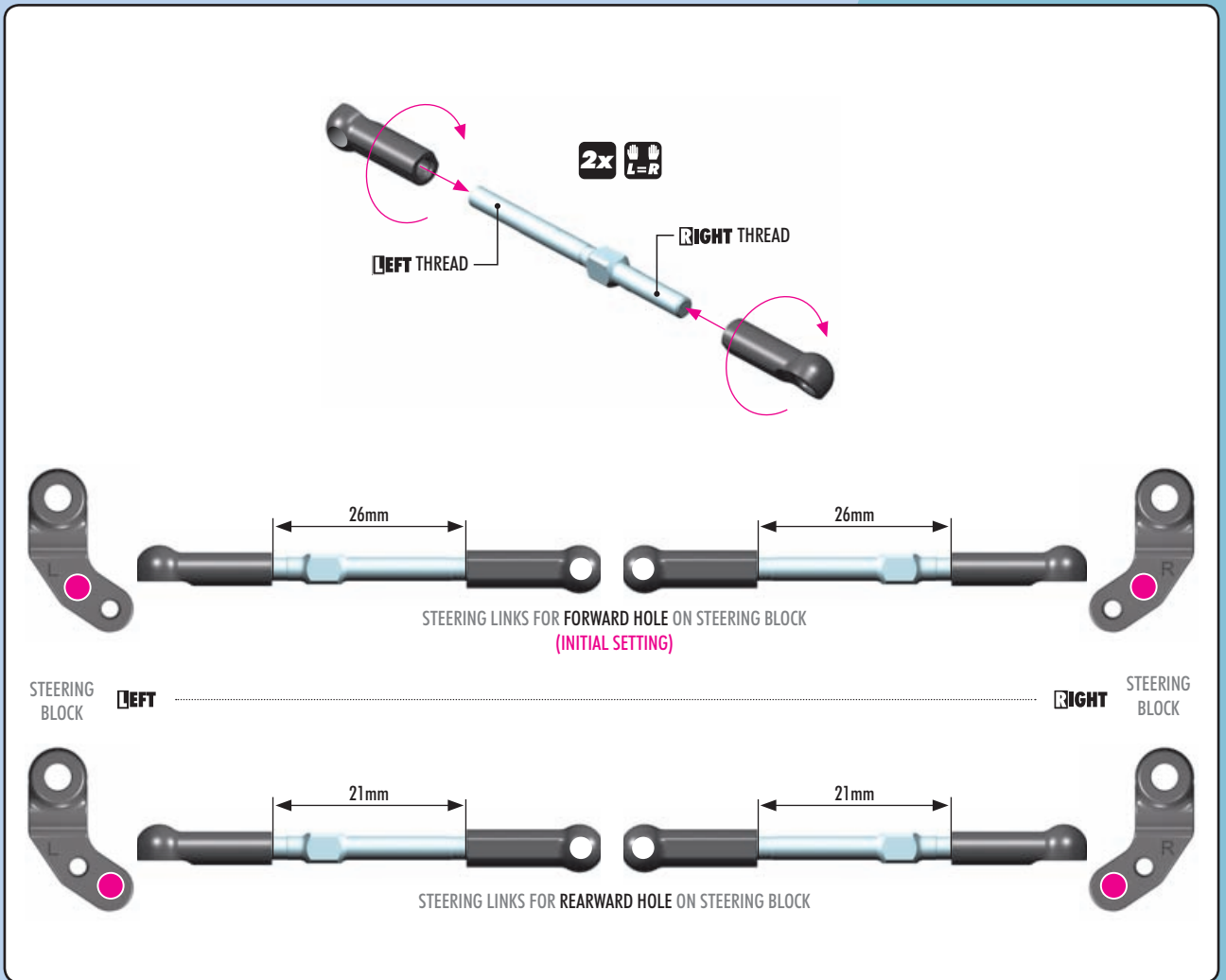



VIDEO TECH TIP STEERING SYSTEM

ACKERMANN SETTING

Ackermann is directly affected by wheelbase length and linkage position on the steering blocks. The configurations below are based on the use of a standard servo.

ALTERNATIVE 1: for MICRO AND STANDARD SERVO

Wheelbase: LONG
Steering block: REAR holes
Servo mounting: AHEAD of posts
Servo saver: ballstuds BEHIND

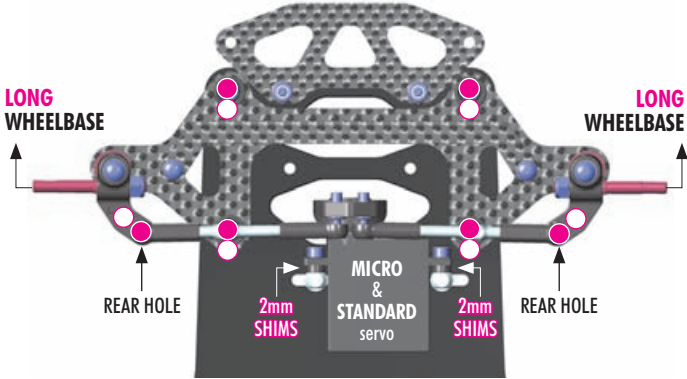

Use 2mm thick shims between servo and posts.

ALTERNATIVE 2: for MICRO SERVO

Wheelbase: LONG
Steering block: FRONT holes
Servo mounting: AHEAD of posts
Servo saver: ballstuds BEHIND

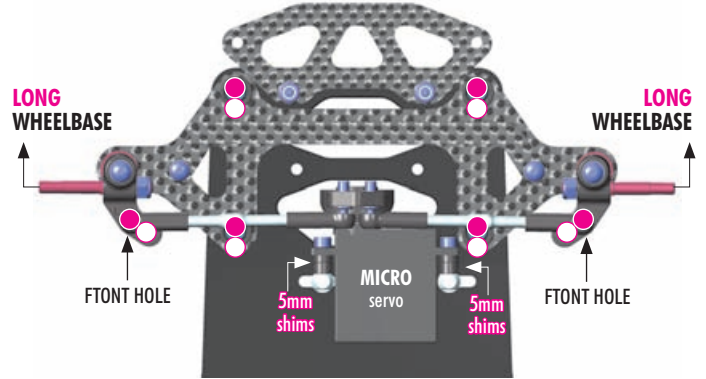

Use 5mm thick shims between servo and posts.

ALTERNATIVE 3: for MICRO AND STANDARD SERVO

Wheelbase: SHORT
Steering block: FRONT holes
Servo mounting: AHEAD of posts
Servo saver: ballstuds BEHIND

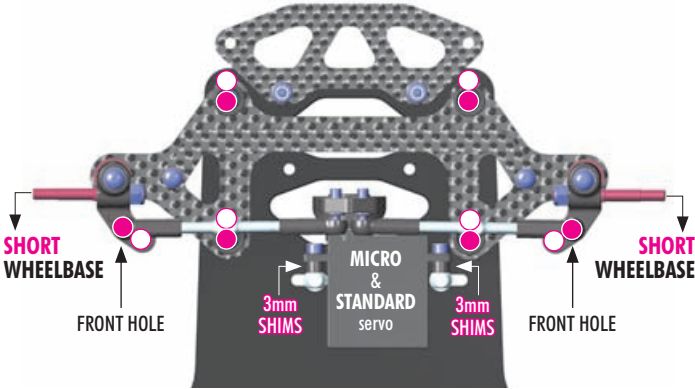

Use 3mm thick shims between servo and posts.

ALTERNATIVE 4: for MICRO AND STANDARD SERVO

Wheelbase: SHORT
Steering block: REAR holes
Servo mounting: AHEAD of posts
Servo saver: ballstuds BEHIND

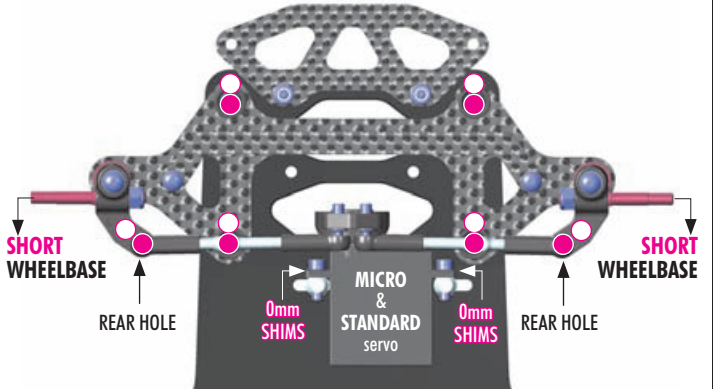

Do not add any shims between servo and posts.

ALTERNATIVE 5: for STANDARD SERVO

Wheelbase: LONG
Steering block: FRONT holes
Servo mounting: BEHIND posts
Servo saver: ballstuds IN FRONT

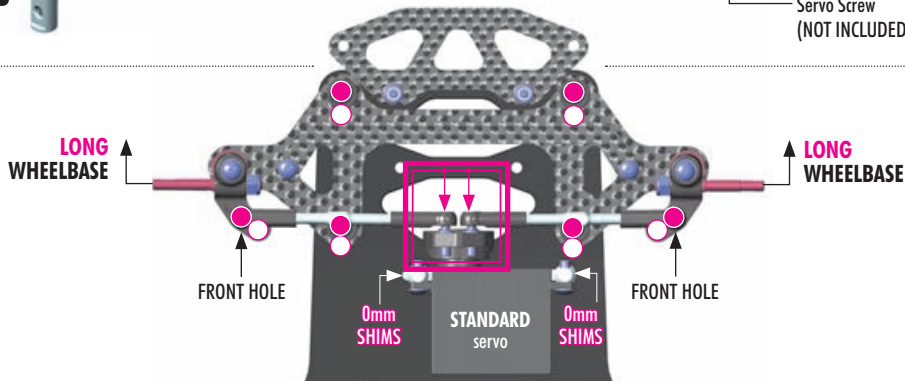
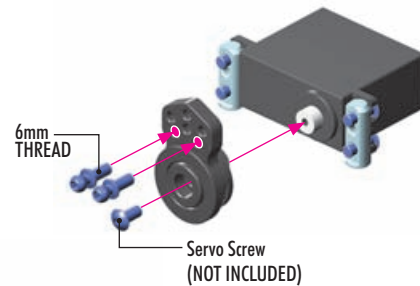
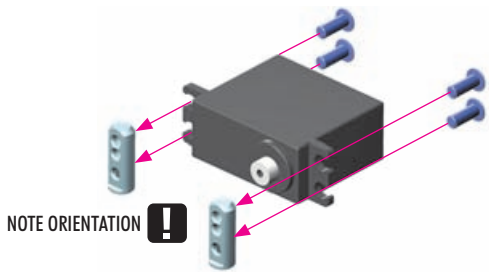

Mount the 6mm ball studs on the forward side of the servo saver.

5. FINAL ASSEMBLY

EU **US**

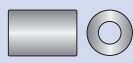

303130-K
SHIM 3x6x9



902316
SH M3x16



980210
P 2x10

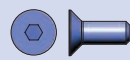
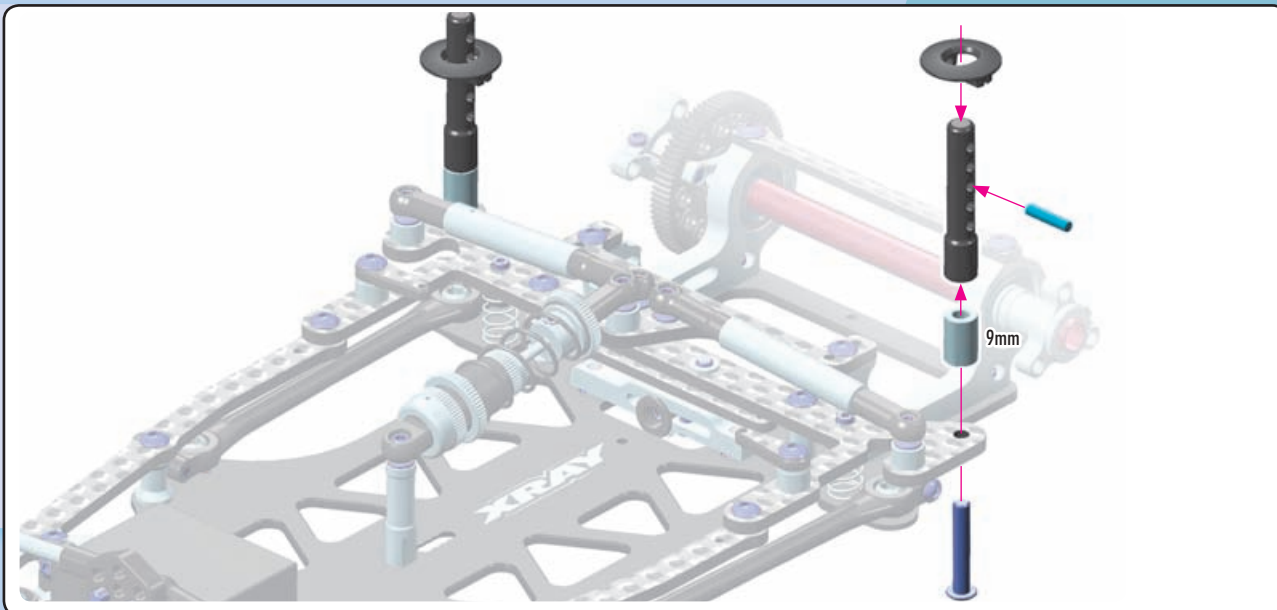

903308
SFH M3x8

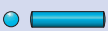

980210
P 2x10

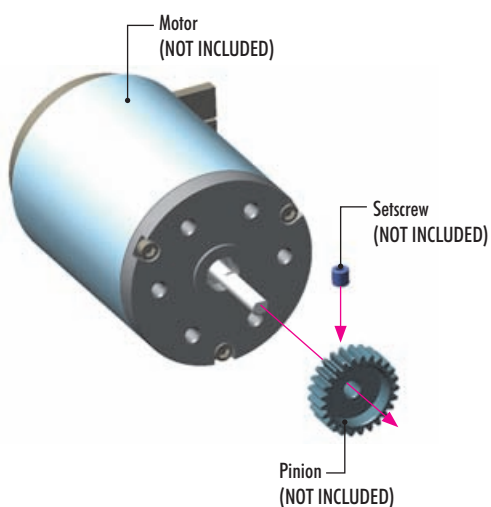
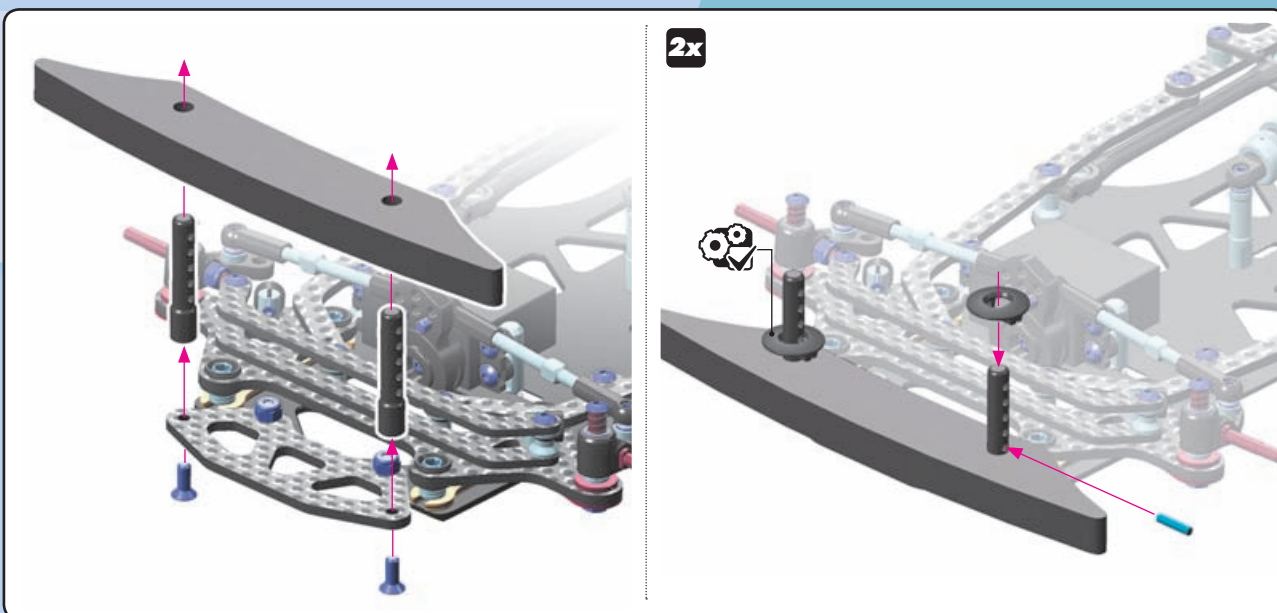

ALU PINION GEARS 64P

#305968	18T	OPTION	#294137	37T	OPTION
#305969	19T	OPTION	#294138	38T	OPTION
#305970	20T	OPTION	#294139	39T	OPTION
#305971	21T	OPTION	#294140	40T	OPTION
#305972	22T	OPTION	#294141	41T	OPTION
#305973	23T	OPTION	#294142	42T	OPTION
#305974	24T	OPTION	#294143	43T	OPTION
#305975	25T	OPTION	#294144	44T	OPTION
#294126	26T	OPTION	#294145	45T	OPTION
#294127	27T	OPTION	#294146	46T	OPTION
#294128	28T	OPTION	#294147	47T	OPTION
#294129	29T	OPTION	#294148	48T	OPTION
#294130	30T	OPTION	#294149	49T	OPTION
#294131	31T	OPTION	#294150	50T	OPTION
#305982	32T	OPTION	#294152	52T	OPTION
#294133	33T	OPTION	#294154	54T	OPTION
#305984	34T	OPTION	#294156	56T	OPTION
#305985	35T	OPTION	#294158	58T	OPTION
#294136	36T	OPTION	#294160	60T	OPTION

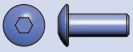

902308
SH M3x8

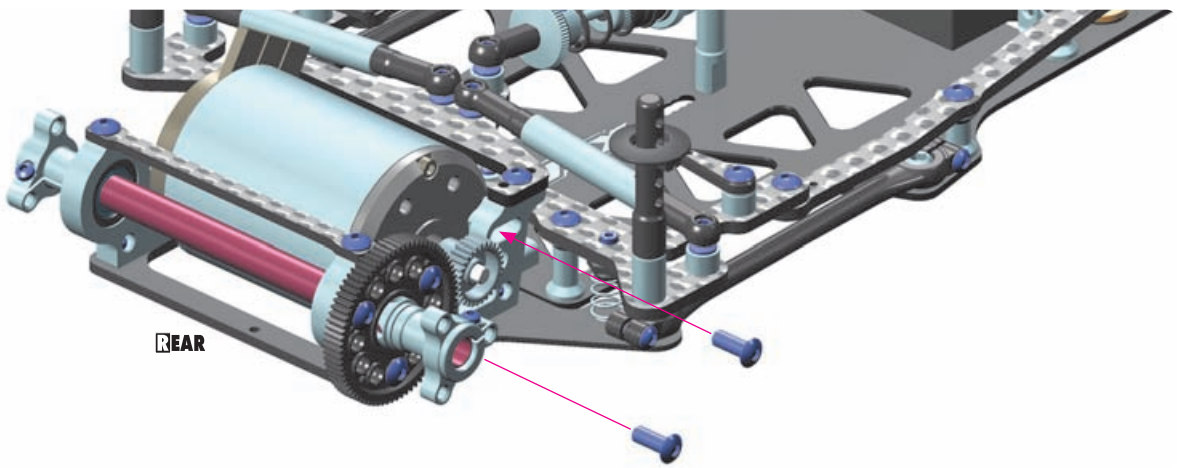

REAR

GEAR MESH:

Adjust the gear mesh so there is appropriate space between the spur gear and pinion teeth. There should be a very small amount of freeplay.

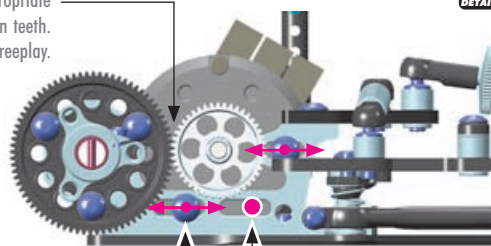

INSTALLATION:

Installation of the third motor mount screw is recommended for added security to prevent motor movement during a run and to extend gear lifespan.

For an additional motor security you may use the 3rd extra screw included in the kit.



VIDEO TECH TIP



ELECTRONICS
INSTALLATION

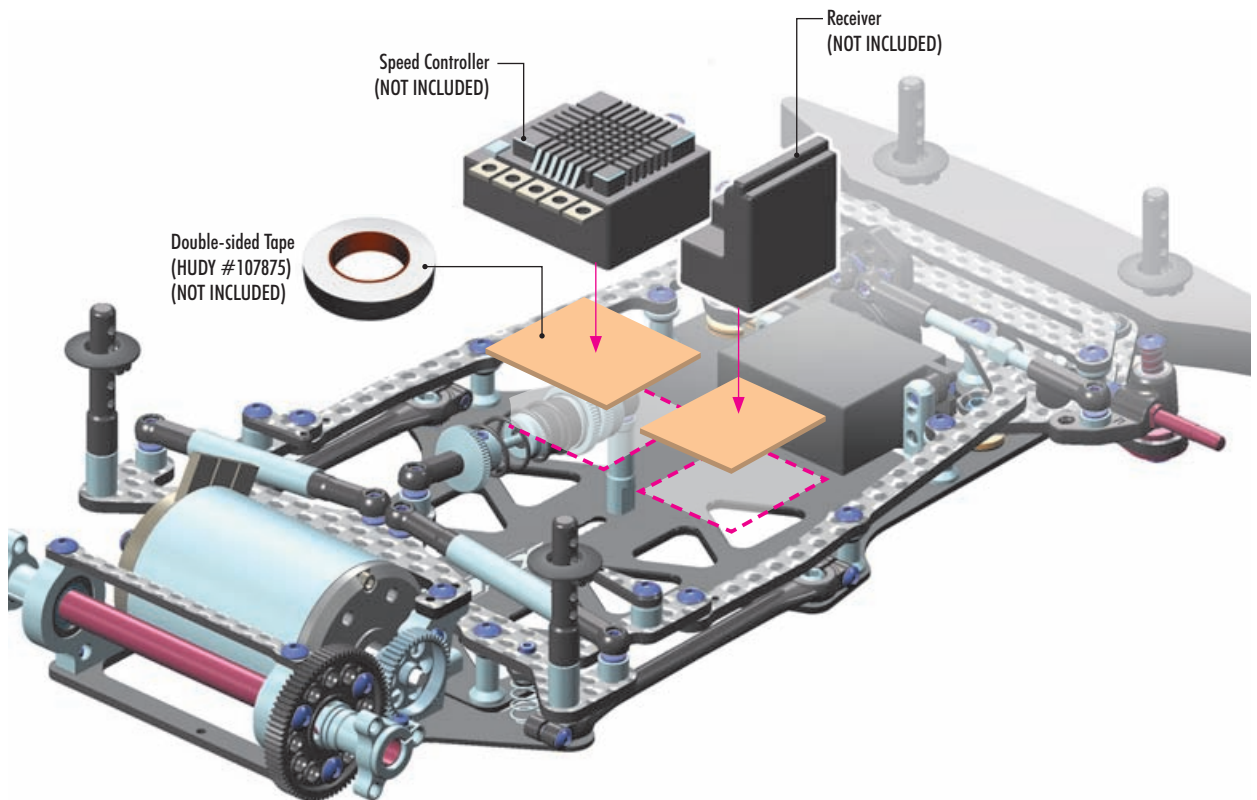



903310
SFH M3x10



960031
ALU N M3

Battery Pack (NOT INCLUDED)

Disconnect the shock absorber and position the pack at an angle to clear the surrounding brackets when installing or removing the battery.

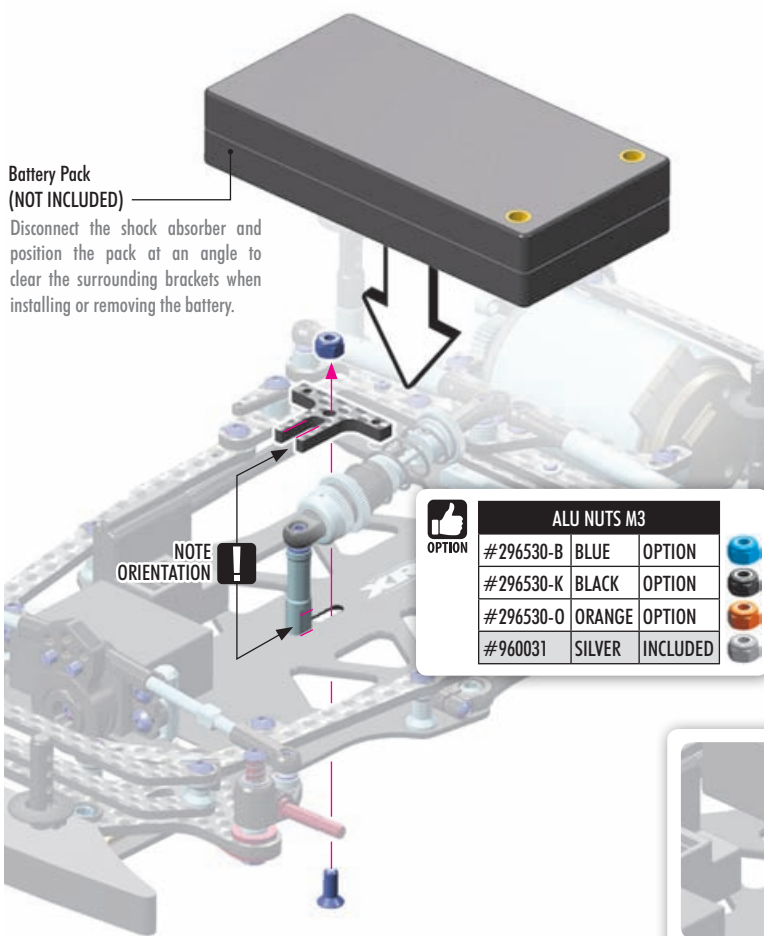

BATTERY BACKSTOP

The new adjustable battery backstop system secures the battery in the car in a tweak-free, non-fixed manner to help improve traction and makes it more stable and easier to drive.

It is very important that battery has a very small amount of play in all directions so it does not tweak the car, but the play cannot be too much otherwise the battery may fall out in crashes.

Adjust the shim thickness to match battery pack height. If there is no play between the backstop and pack, use a thicker shim. If it is too loose, use a thinner shim to reduce the gap.

[note] Make sure to keep a small amount of play

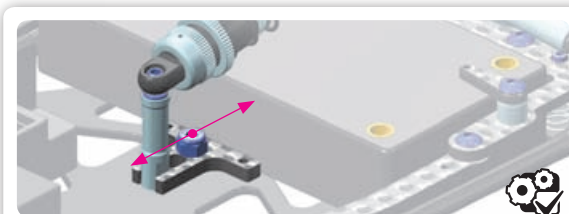
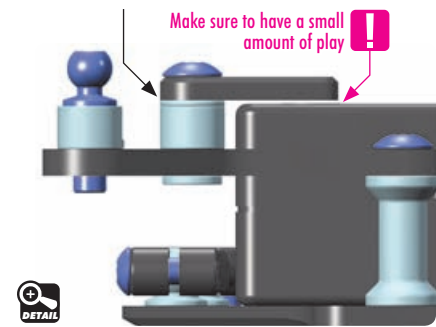

BATTERY MOUNTING POSITIONS

The X12 has 4 battery positions. The further forward the battery is positioned in the car, the easier it will be to drive but less responsive. The further rearward the battery is located, the more aggressive it will feel with more steering.



VIDEO TECH TIP



BATTERY MOUNTING SYSTEM

Position 1 = Most aggressive setting

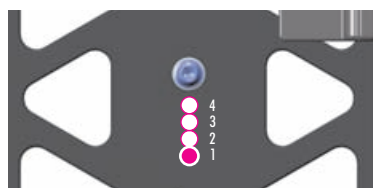

INITIAL SETTING - Use position 2

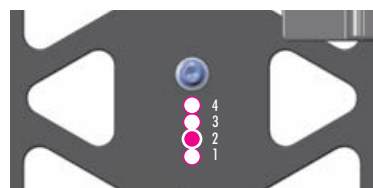

Position 4 = Easiest to drive

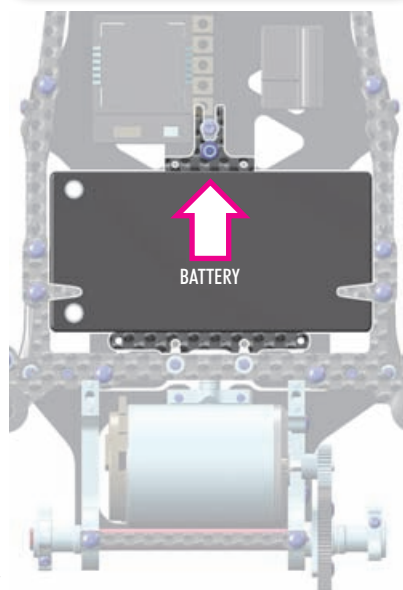
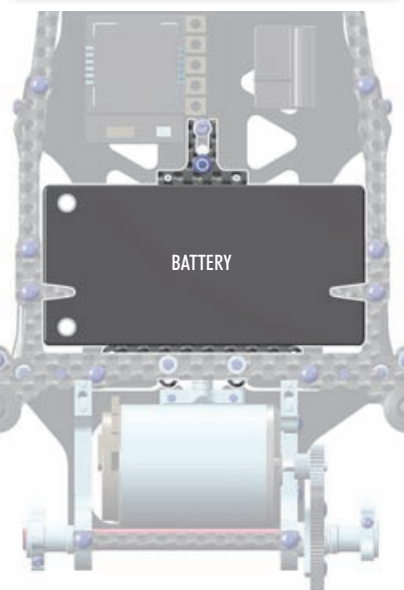
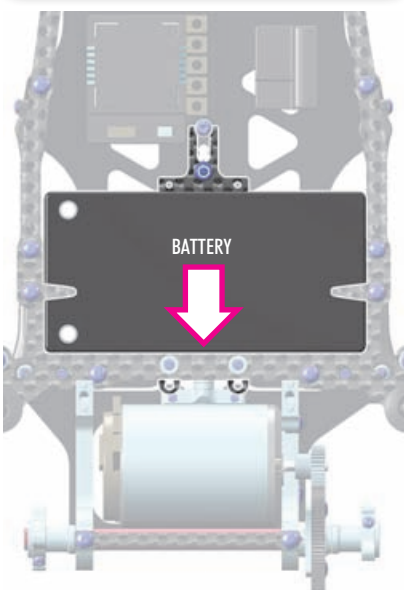
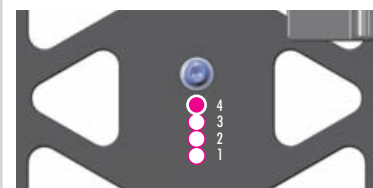



372290
SHIM 3.2x4.8x0.5

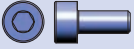

375390
ALU SCH M3x8



951851
BB 1/8"x5/16"x9/64"



960031
ALU N M3



VIDEO TECH TIP



FRONT DROOP & RIDE HEIGHT



TWEAK & SIDE SPRINGS SETTING



BODYSHELL MOUNTING

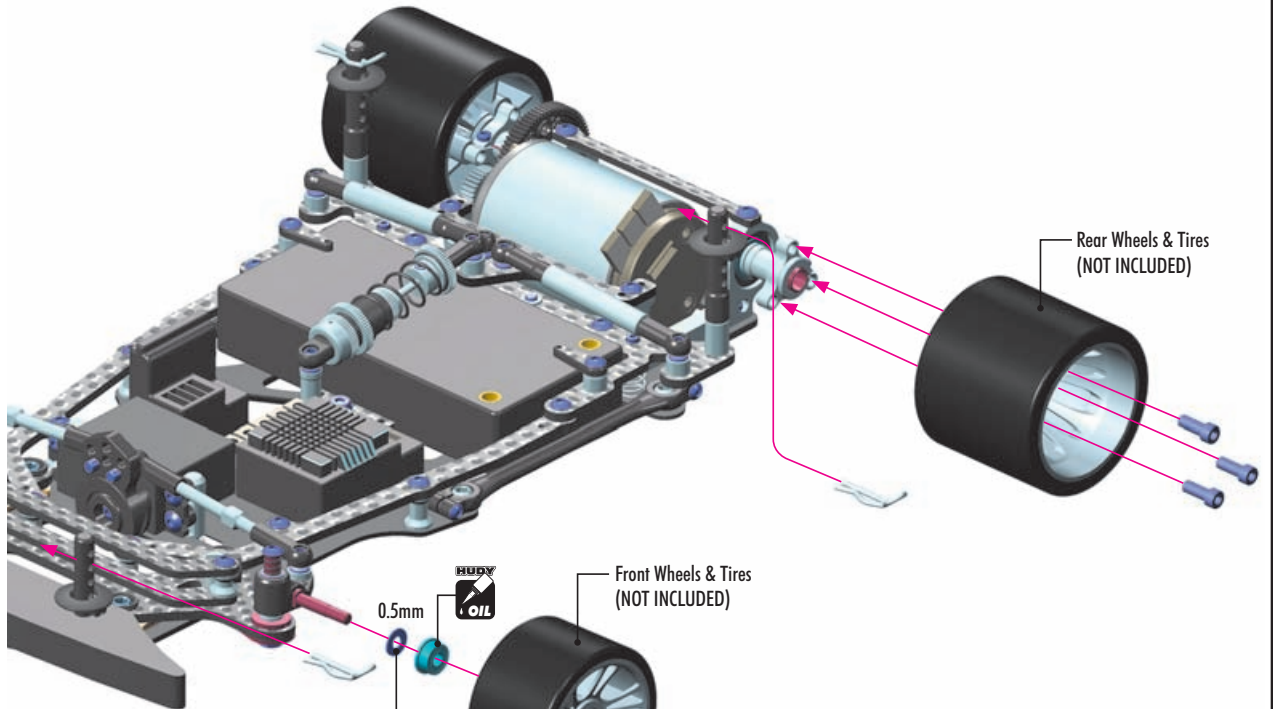

FRONT TRACK-WIDTH
The shim behind the wheel bearing affects the front track-width.

WIDER TRACK-WIDTH
Easier to drive, less steering, less responsive.

NARROWER TRACK-WIDTH
More steering, more responsive, but more difficult to drive.

GENTLY TIGHTEN
the wheel nuts so the wheel turns freely, but without excessive axial play.

Bearing Oil
(HUDY #106230)



OPTION

ALU NUTS M3

#296530-B	BLUE	OPTION	
#296530-K	BLACK	OPTION	
#296530-O	ORANGE	OPTION	
#960031	SILVER	INCLUDED	

www.teamxray.com

XRAY EUROPE

XRAY, K VÝSTAVISKU 6992, 91101 TRENCIN, SLOVAKIA, EUROPE
PHONE: +421-32-740 11 00, FAX: +421-32-740 11 09, info@teamxray.com

XRAY USA

RC AMERICA, 2030 Century Center Blvd #15, Irving, TX 75062, USA
PHONE: 214-744-2400, FAX: 214-744-2401, xray@rcamerica.com



[/TeamXray](#)



[/TeamXray](#)



[/TeamXray](#)



[/XrayRacing](#)



[/+TeamXrayRC](#)