

OUTLAW 4 SPRINT CAR

INSTRUCTIONS



#0724 Outlaw 4 Racing Kit

Manufactured by:

Custom Works RC Products

760-B Crosspoint Drive

Denver, NC 28037

www.customworksrc.com





Thank you for purchasing the Outlaw 4 Sprint Car! The Outlaw sprint car platform has been developed for loose dirt buggy tire racing. In this kit you will find the 4th evolution of the car which features several improvements including a new 2.6 to 1 transmission and front and rear axles for hex wheels.

This kit includes most of the parts required for the build. The following additional equipment must be added to complete the car. (Be sure to check if the track you plan on racing at has any motor, battery or speed control restrictions.)

- Surface transmitter and receiver (minimum 2 channel.)
- 1/10th scale electronic speed control
- 540 size brushless motor
- Pinion gear (48 pitch, appropriate size for motor)
- 2S hard case "shorty" LiPo battery
- Steering servo (standard or low profile)
- Front and rear wheels and tires (2.2" diameter AE style hex wheels)
- Silicone shock oil (30 weight recommended)
- Lexan paint and/or vinyl wrap for body

Tools

The following tools are provided in the kit and will get you started. We suggest that you purchase higher quality tools for future maintenance.

- .050 Allen key
- 1.5mm Allen key
- 1/16 Allen key
- 5/64 Allen key
- 3/32 Allen key
- Turnbuckle & 3/16 wrench

Additional tools

These tools are recommended for the build and may be required to complete.

- Curved scissors
- Needle nose pliers
- Hobby knife
- Blue thread-lock
- Assorted sandpaper
- 7mm hex driver

Building tips

Parts are made with tight tolerance and held to the side of a "snug" fit as wear is expected over time. Try as we may, occasionally a burr may remain in a part and fit more tightly than desired. It is ok to use 400 Grit Sandpaper or a .125" drill to SLOWLY relieve a part from time to time. Suspension components should always pivot and swivel freely but without too much slop.

A lite to medium strength (usually the blue variety) thread locking fluid is suggested for all parts where metal screws thread into other metal parts. This will keep the screws from vibrating loose during operation and still allow the screw to be removed if needed. Remember it only takes a very small amount of thread-lock to secure the screw.

Do NOT use power screwdrivers to drive screws into parts. The fast rotation speed can melt and strip plastic parts or cross-thread into the aluminum parts.

Lightly sand the edges of the carbon fiber pieces using a medium grade sandpaper to avoid splinters. A thin bead of Super Glue can be used to seal the edges of the carbon fiber for more protection against chips and splinters.

Front Kick-Up Assembly

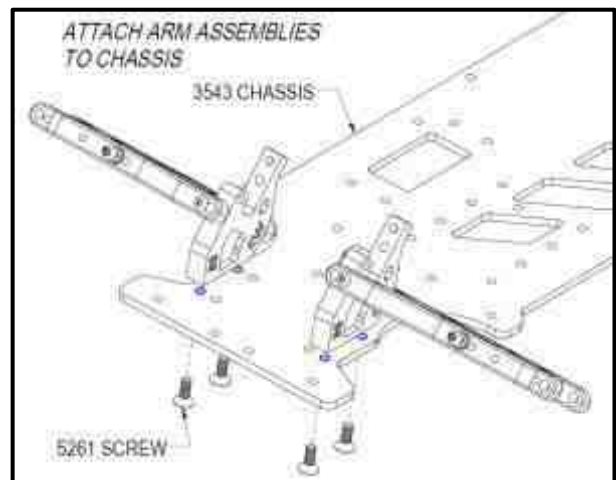
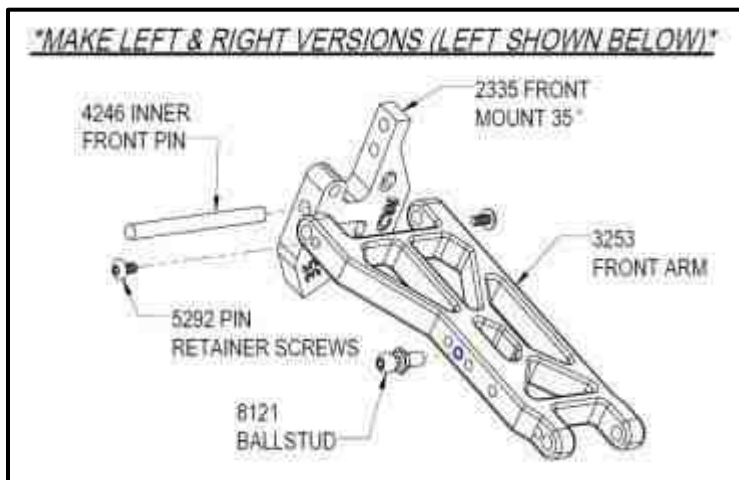

Caster Block Assembly

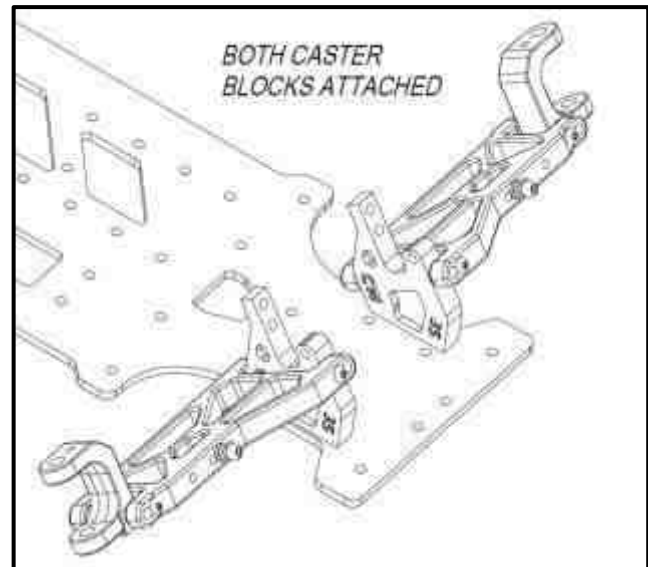
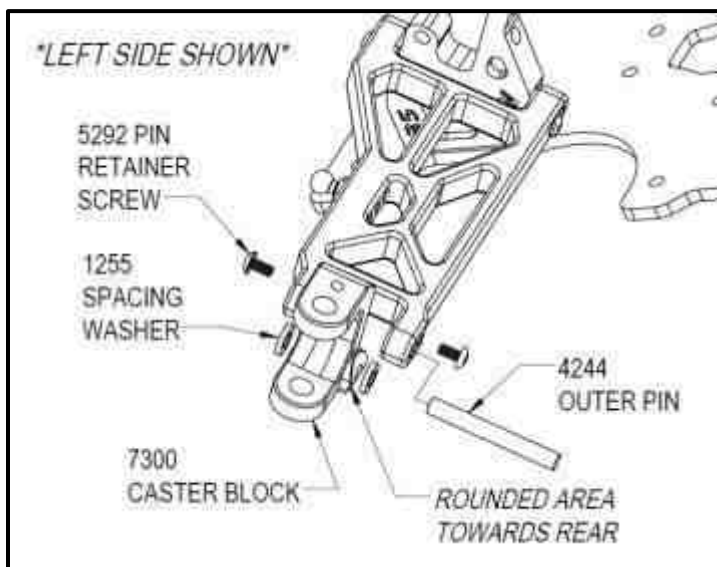

Steering Block Assembly

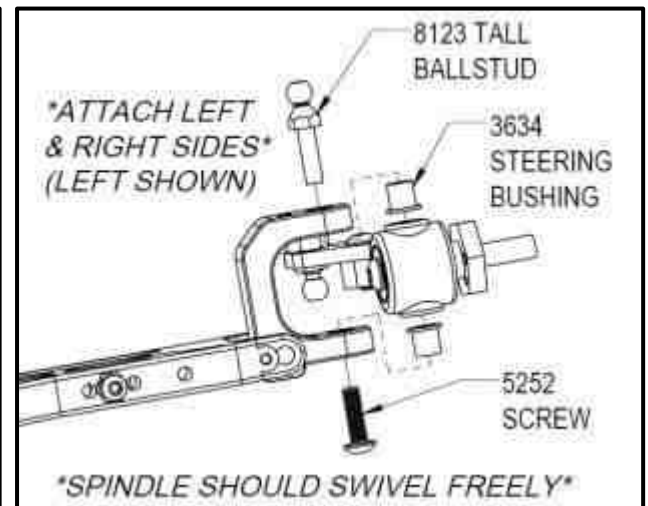
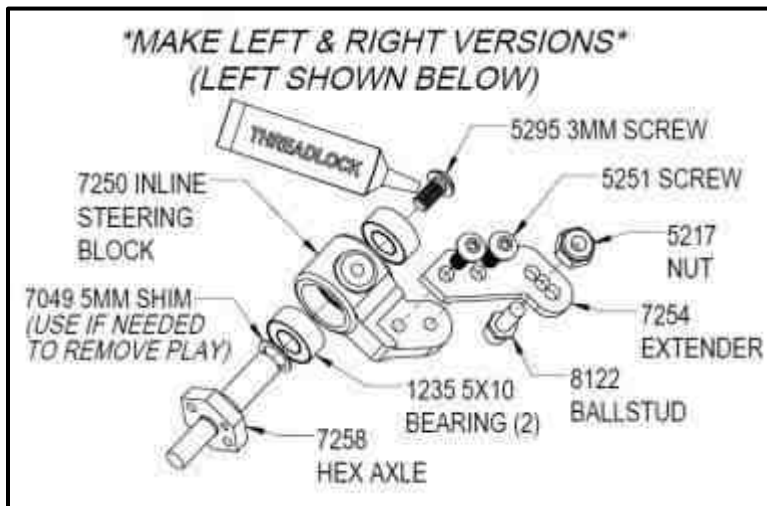

Front Shock Tower Assembly

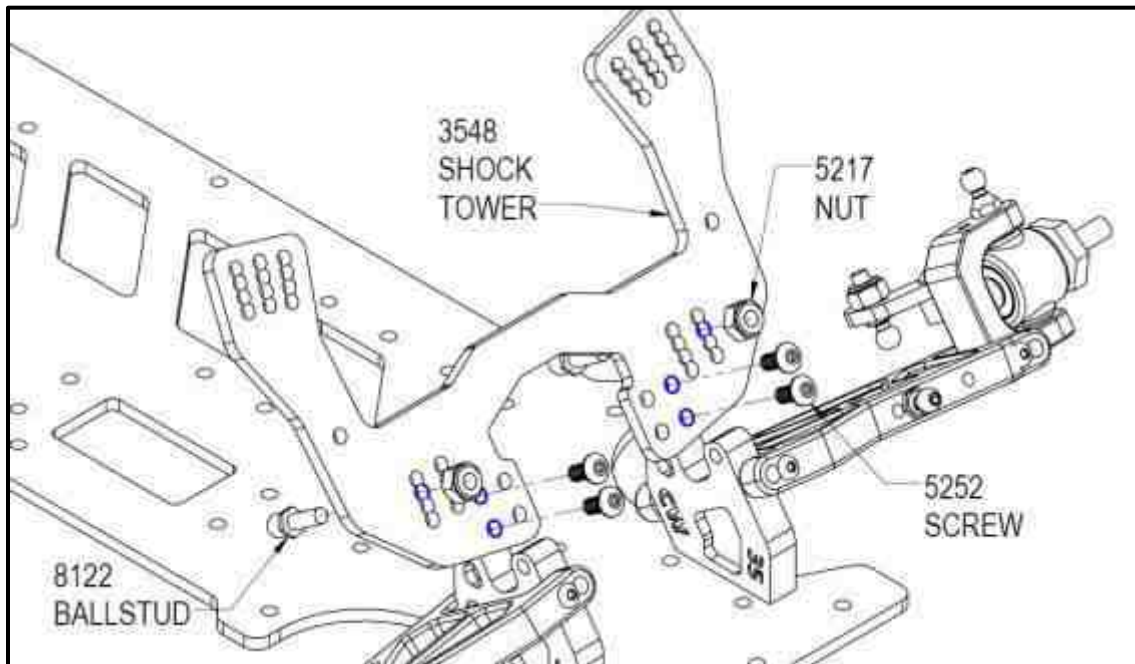

Bellcranks

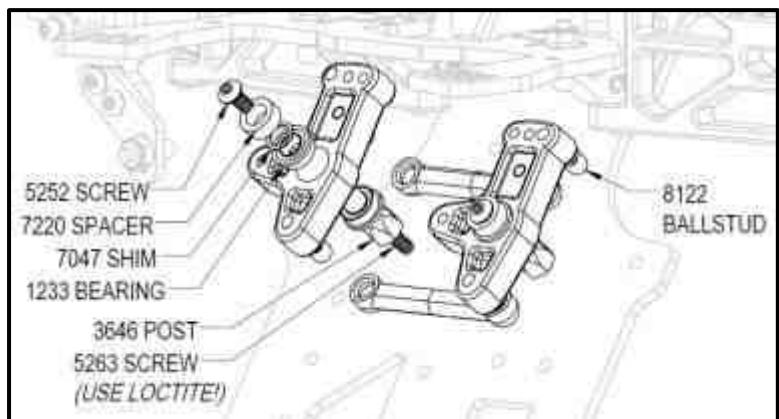
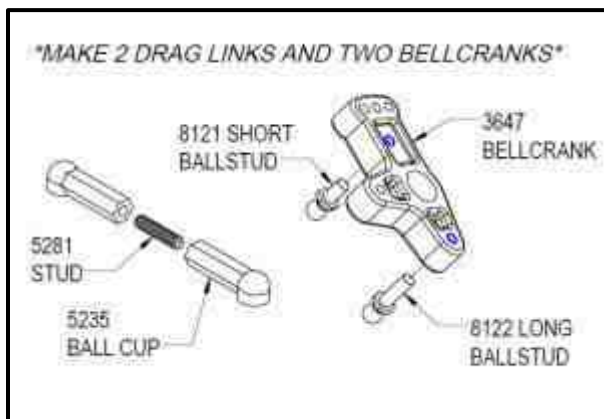

Steering/Front Camber Links

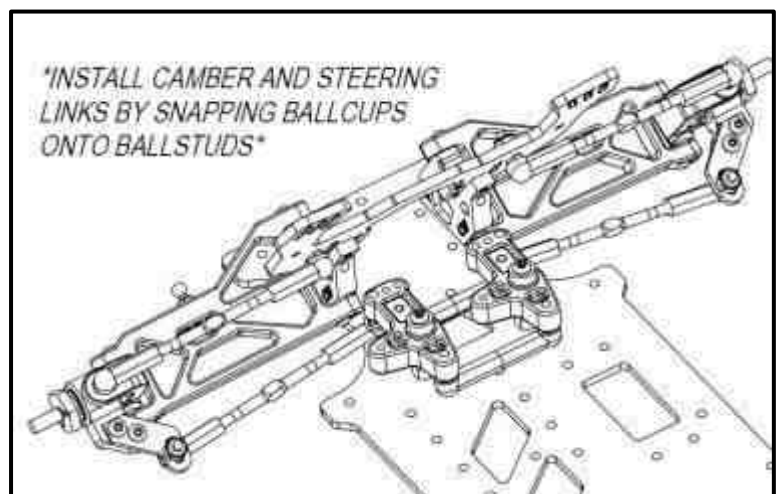
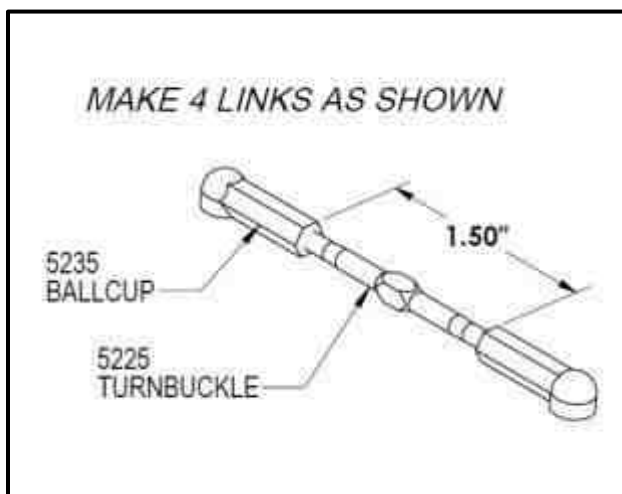

Front Bumper Assembly

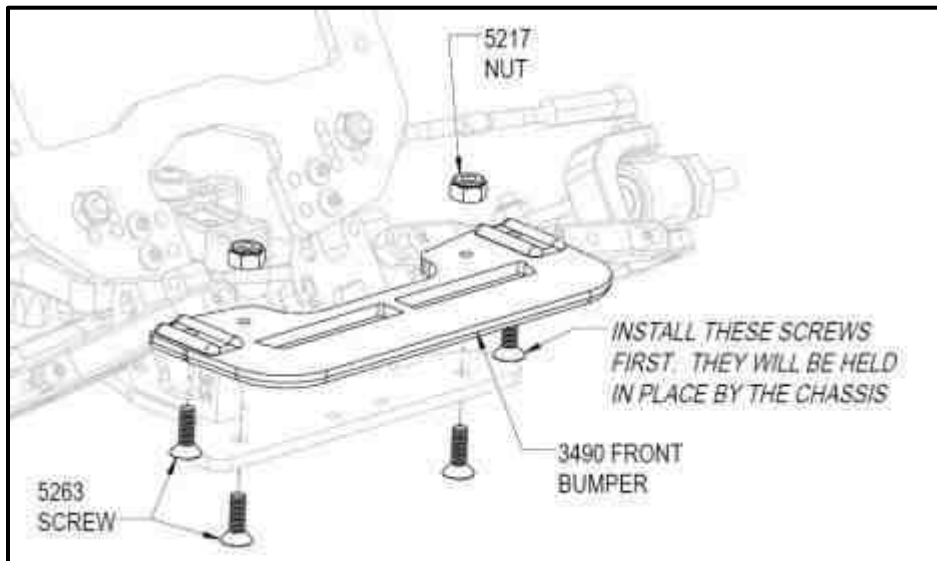

Servo Assembly

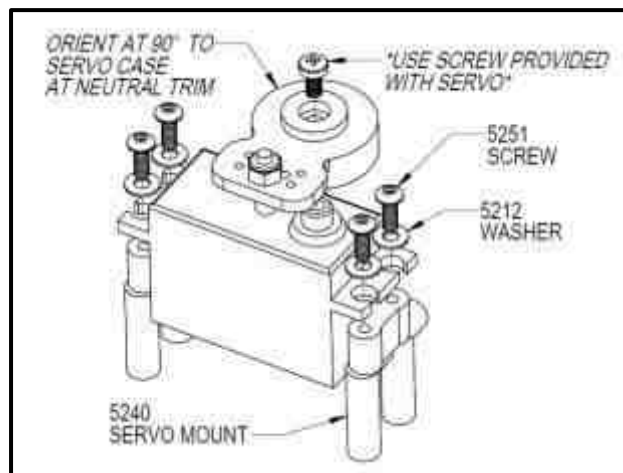
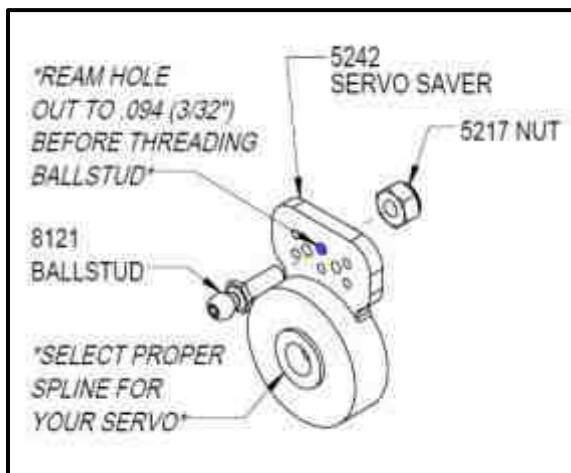

Servo Mounting

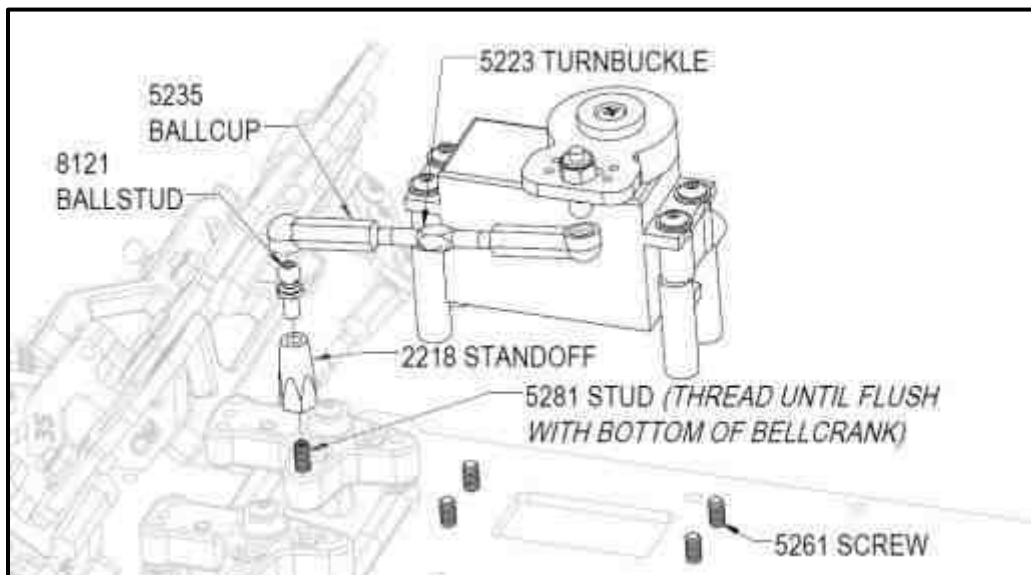

Rear Adjustable Arm Assembly

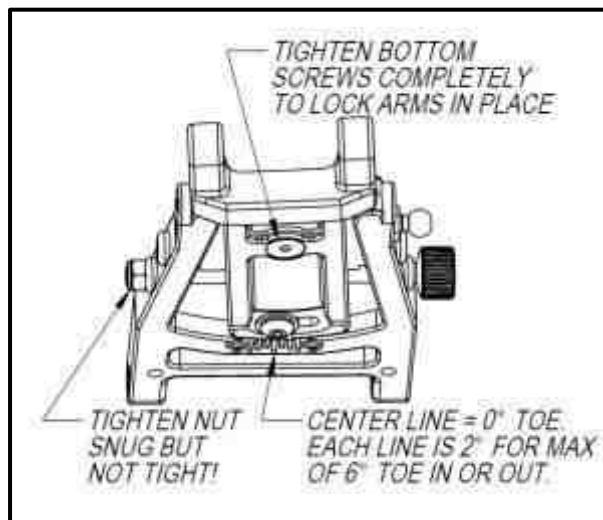
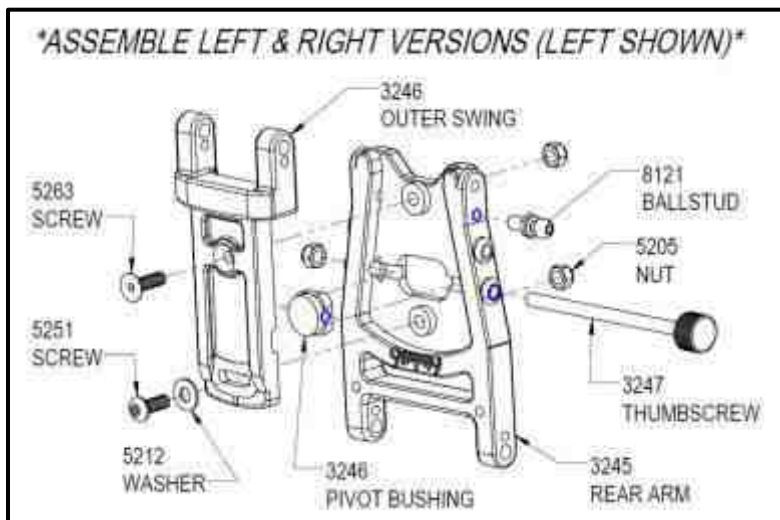

Rear Suspension Mount Assembly

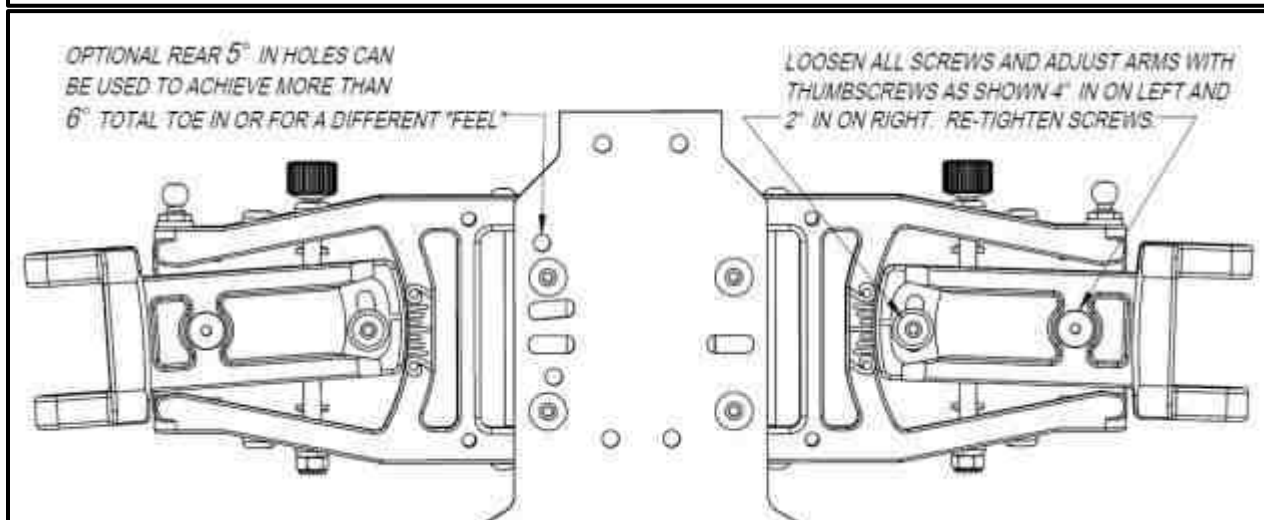
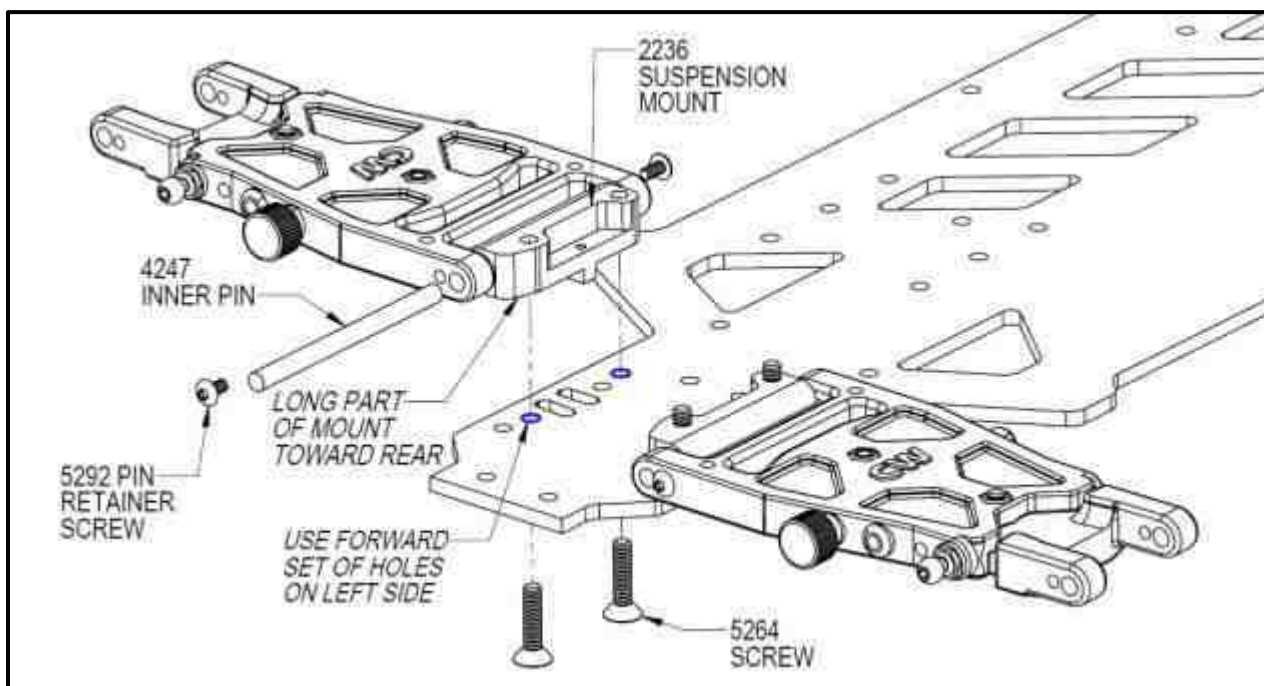

Differential Assembly

STEP 1 - PREP THE THRUST ASSEMBLY



(SET ASIDE UNTIL STEP 3)

STEP 2 - ASSEMBLE THE MALE DIFF HALF

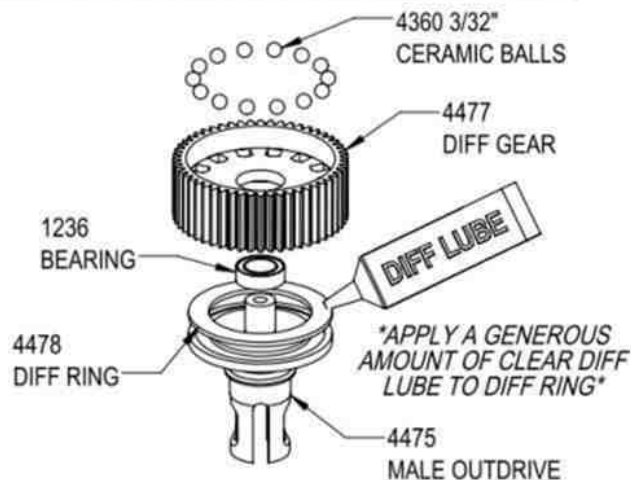

STEP 3 - FINAL DIFF ASSEMBLY

TIGHTEN THE DIFF BOLT INTO THE "T" NUT TO COMPRESS THE SPRING AND SET THE DIFF ACTION. DO NOT OVERTIGHTEN! WHEN THE SPRING FEELS NEARLY COMPRESSED, BACK THE BOLT OUT 1/8 TURN.

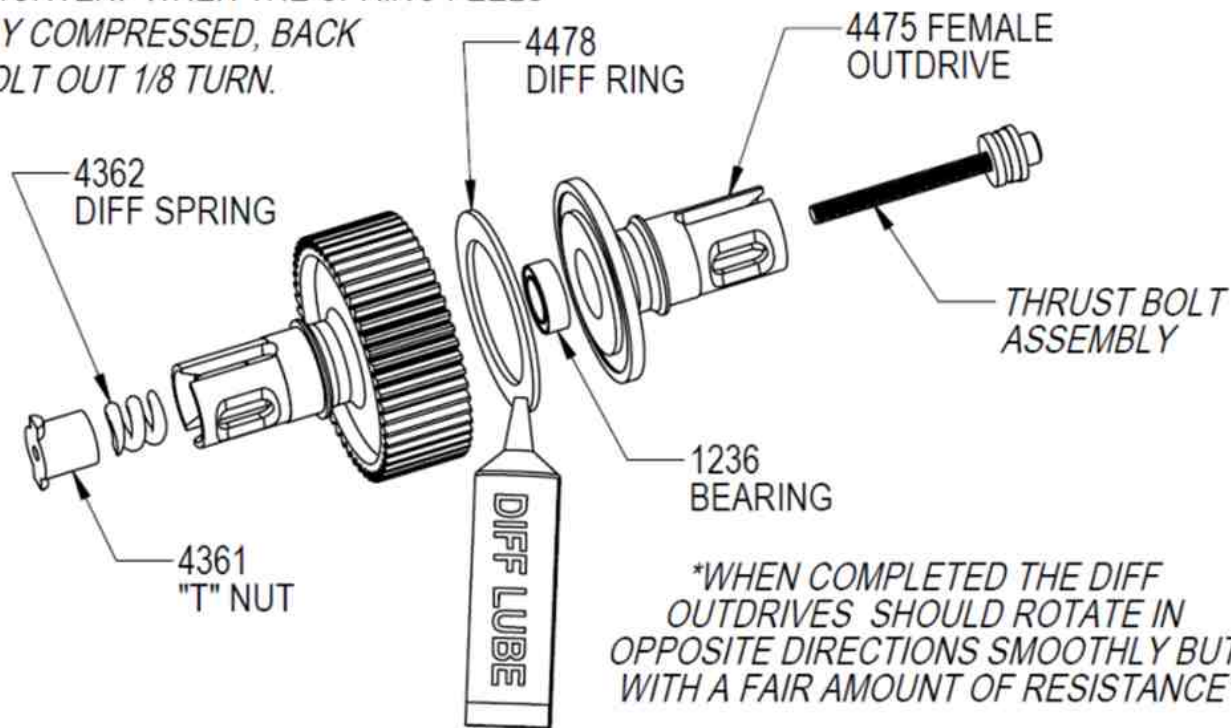

Transmission Assembly

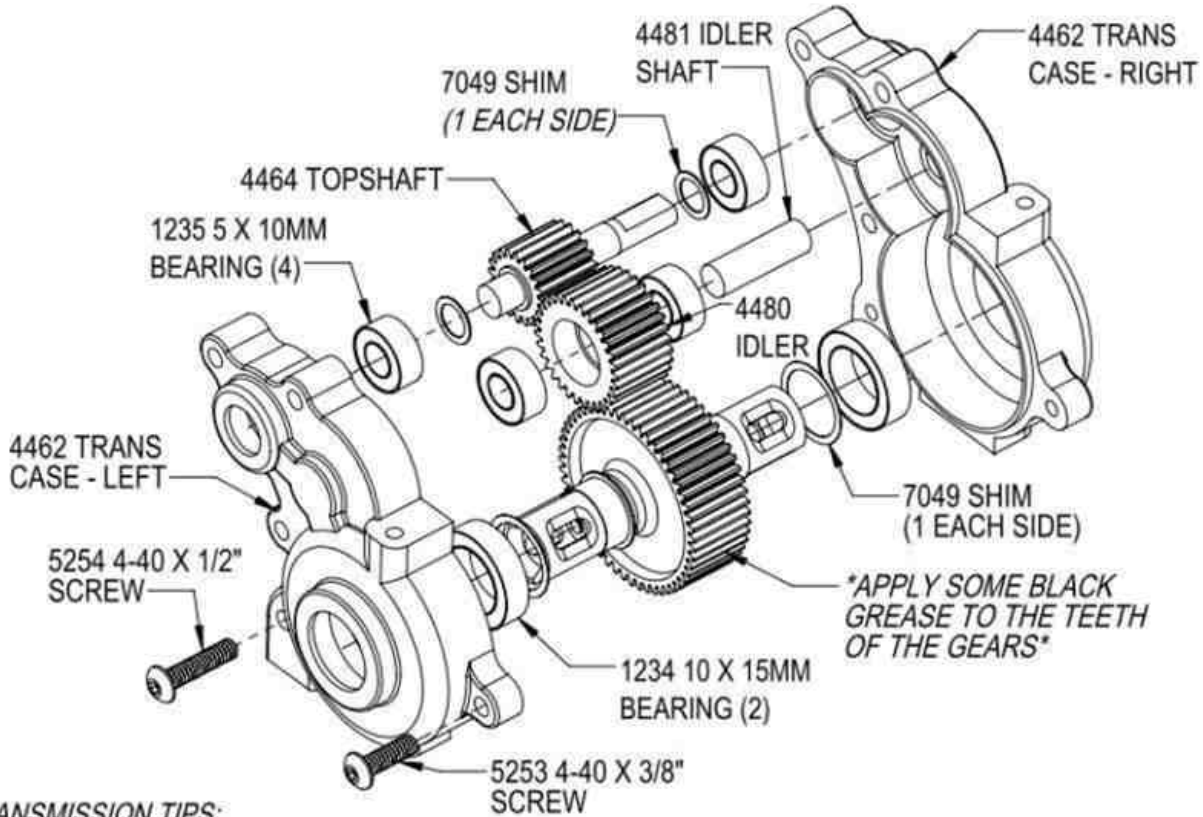

TRANSMISSION TIPS:

1. BEARINGS CAN BE SPRAYED OUT WITH MOTOR SPRAY AND THEN OILED WITH A LITE OIL FOR BETTER FREE-SPIN. (WE RECOMMEND LEAVING THE GREASE IN THE WHEEL AND HUB BEARINGS FOR ADDED PROTECTION FROM DIRT.)
2. ORIENT THE DIFF SCREW TOWARD THE RIGHT SIDE.
3. TRANSMISSION IS 2.6 RATIO REDUCTION.

TROUBLESHOOTING:

1. IF THE OUTDRIVES ARE HOT TO THE TOUCH AFTER A RUN, THE DIFF IS SLIPPING AND NEEDS TIGHTENED.
2. A MELTED IDLER OR DIFF GEAR IS USUALLY CAUSED BY A BAD BEARING.
3. REGULARLY CHECK TRANSMISSION PARTS FOR WEAR AND REPLACE AS NEEDED.

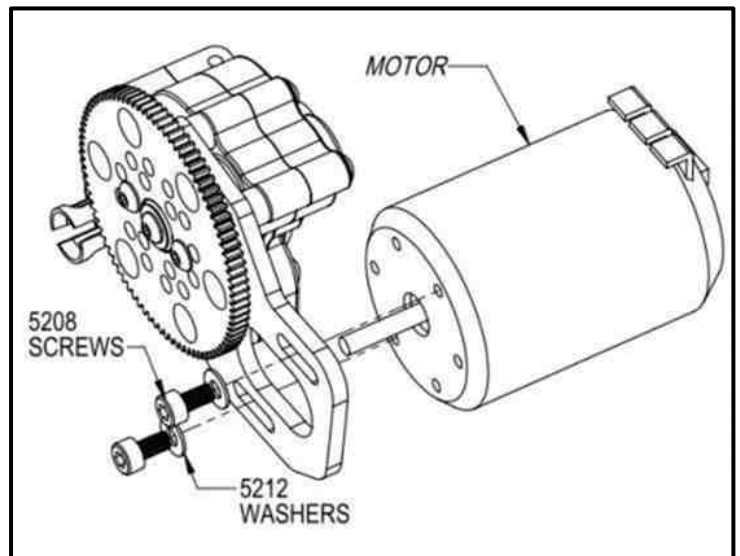
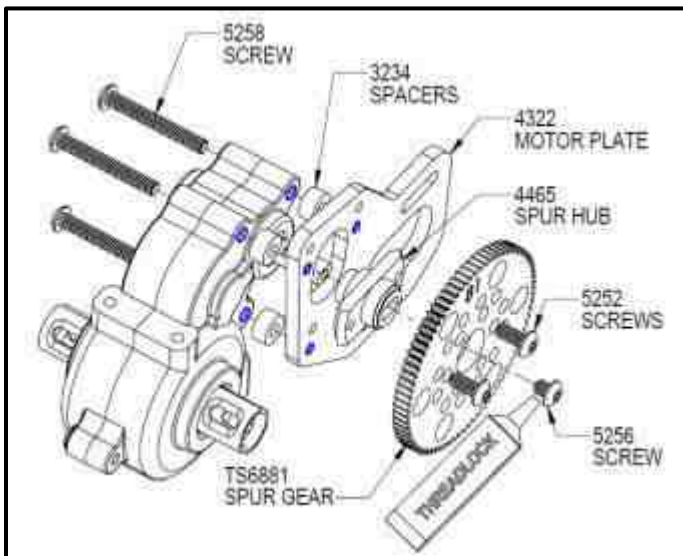

Transmission Assembly continued

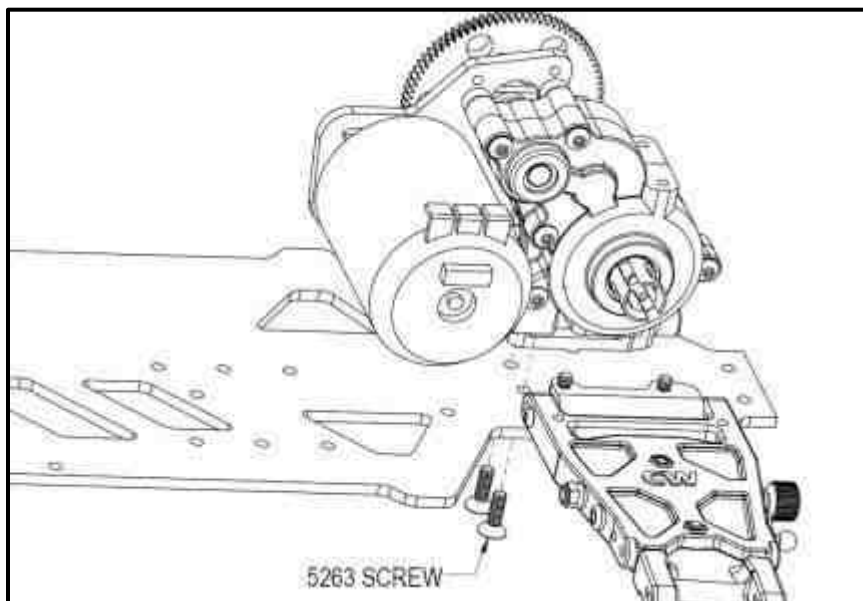

Rear Shock Tower Assembly

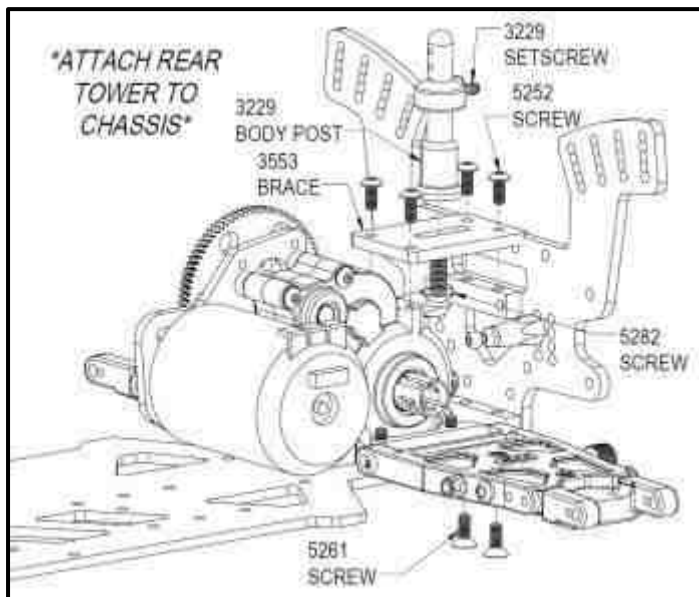
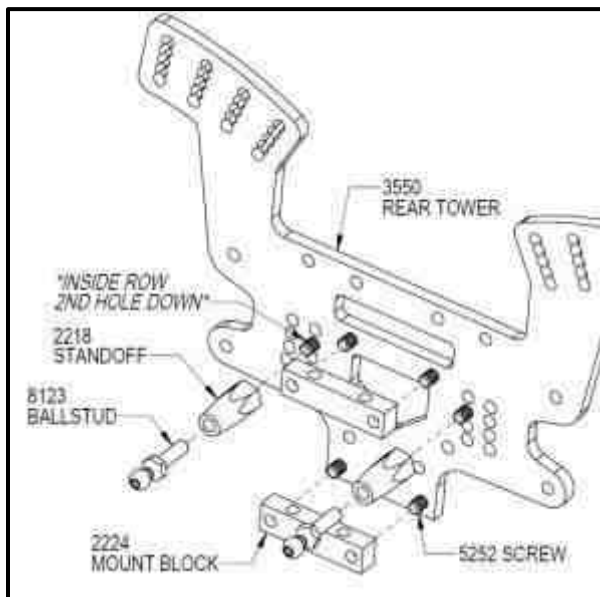

Rear Hub Carrier Assembly

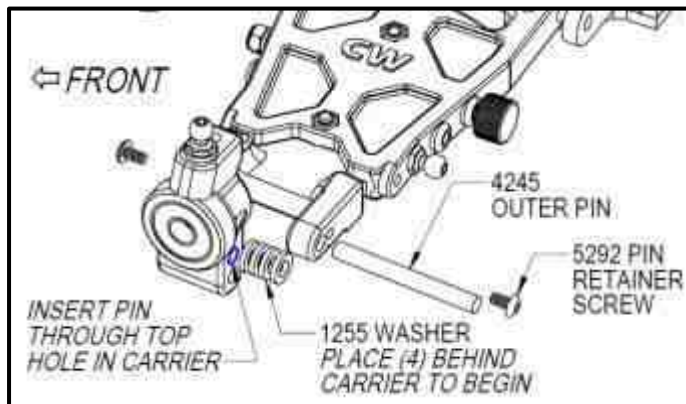
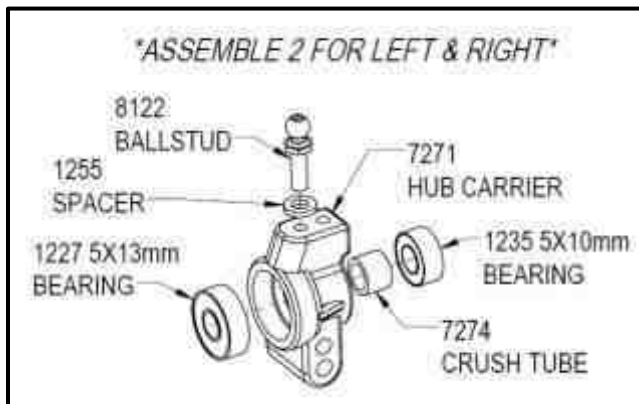

Rear Camber Link Assembly

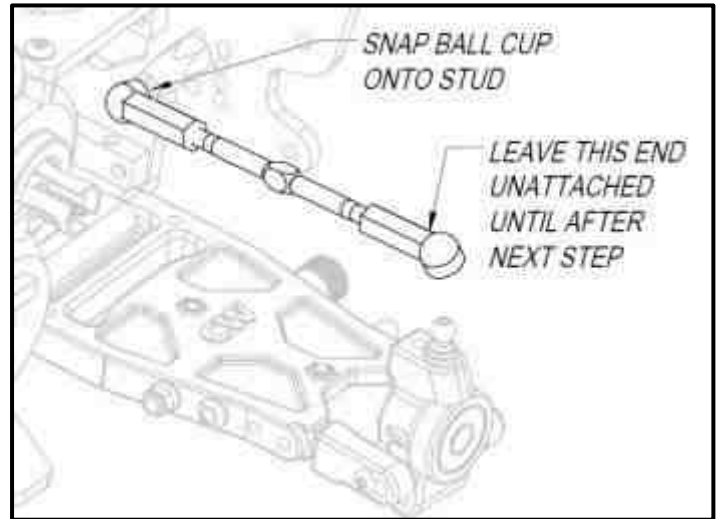
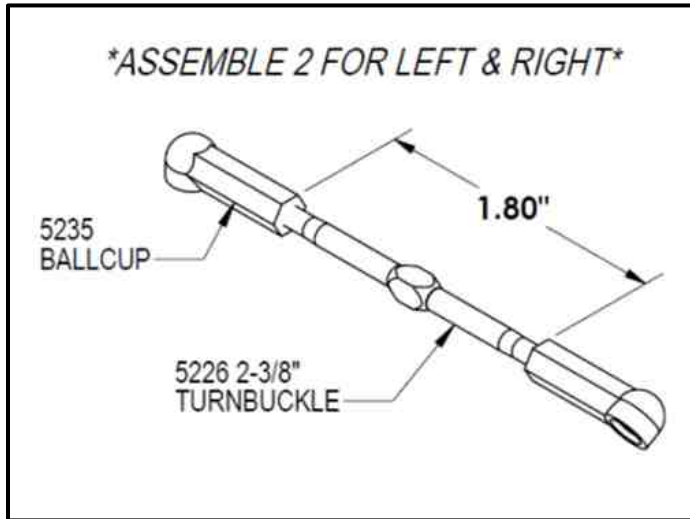

Drivetrain (CVA) Assembly

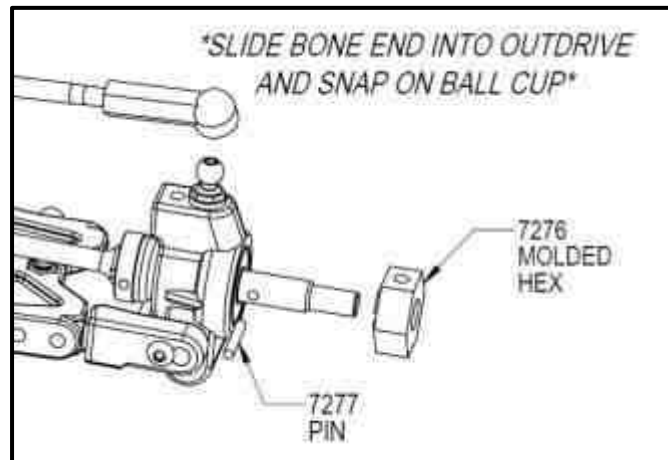
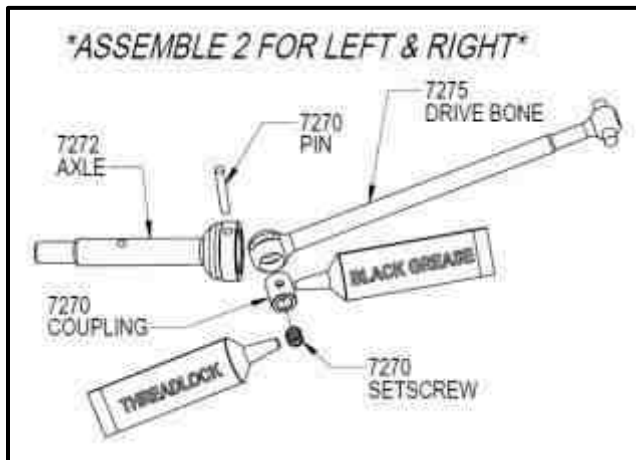

Shock Assembly

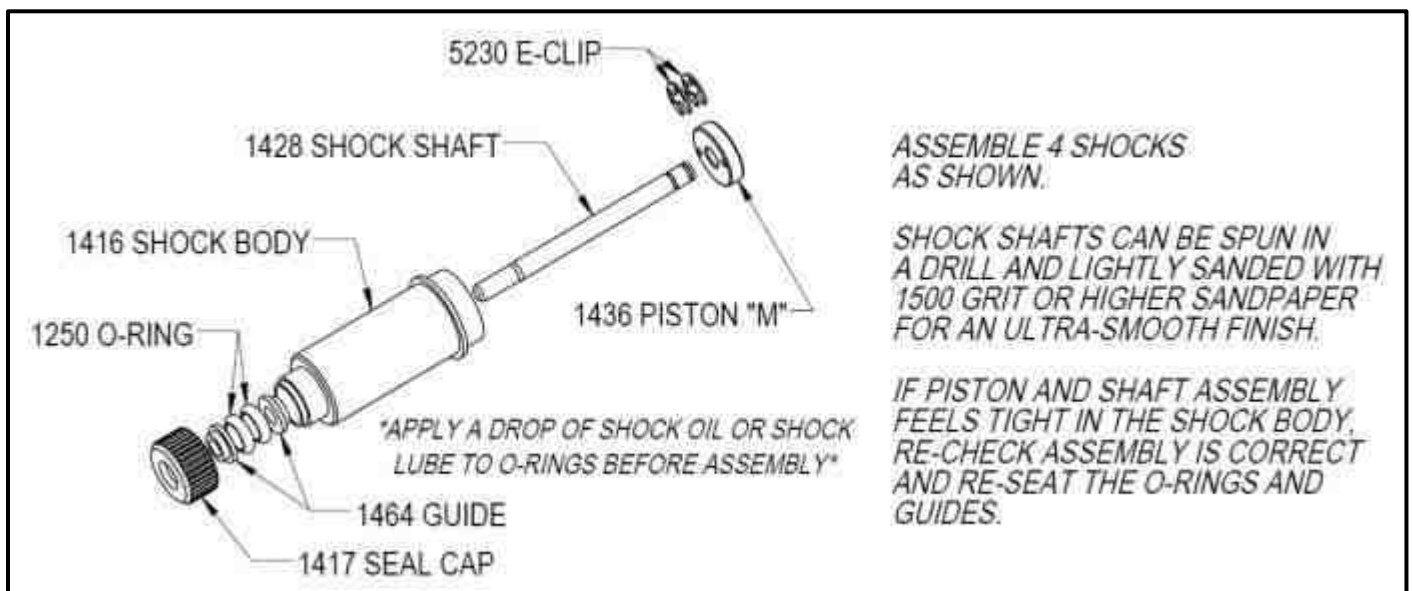

Shock Assembly continued

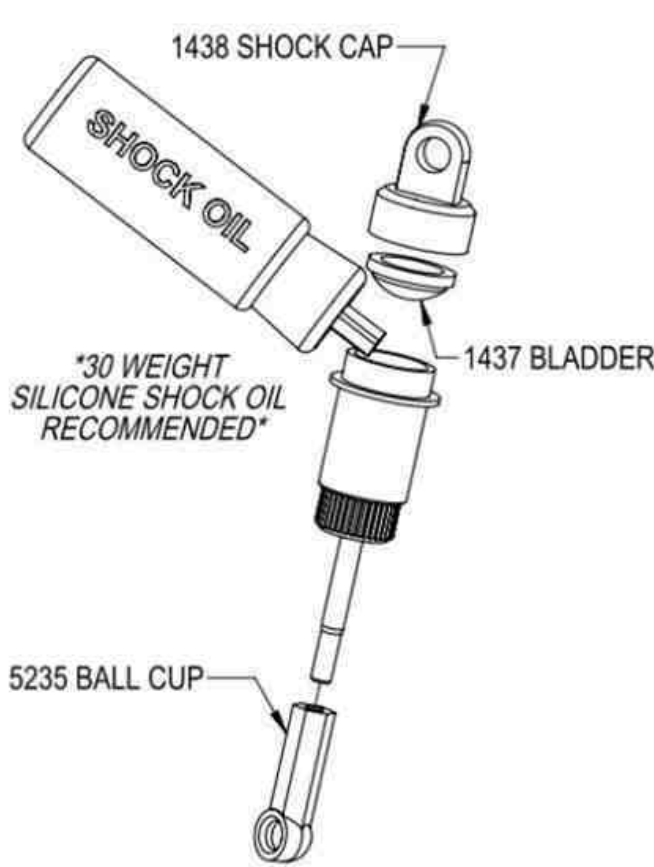

1438 SHOCK CAP

SHOCK OIL

30 WEIGHT SILICONE SHOCK OIL RECOMMENDED

1437 BLADDER

5235 BALL CUP

SHOCK FILLING INSTRUCTIONS

1. EXTEND THE SHOCK ALL THE WAY AND FILL WITH SHOCK OIL. LEAVE SOME ROOM AT THE TOP FOR THE BLADDER.
2. MOVE THE SHOCK SHAFT UP AND DOWN SLOWLY TO REMOVE ANY AIR BUBBLES.
3. BEGIN TO SCREW ON THE SHOCK CAP & BLADDER.
4. SLOWLY PUSH THE SHAFT ALL THE WAY INTO THE SHOCK. ANY EXCESS OIL WILL SEEP OUT OF THE BLEED HOLE IN THE SHOCK CAP.
5. FINISH SCREWING ON THE SHOCK CAP UNTIL IT IS HAND TIGHT.
6. THE SHOCK SHAFT SHOULD NOW MOVE SMOOTHLY UP AND DOWN UNTIL IT GETS WITHIN 1/16" OF THE SHOCK BODY. IF IT GETS TIGHT BEFORE 1/16", THERE IS TOO MUCH OIL IN THE SHOCK. RE-BLEED THE SHOCK USING LESS OIL.

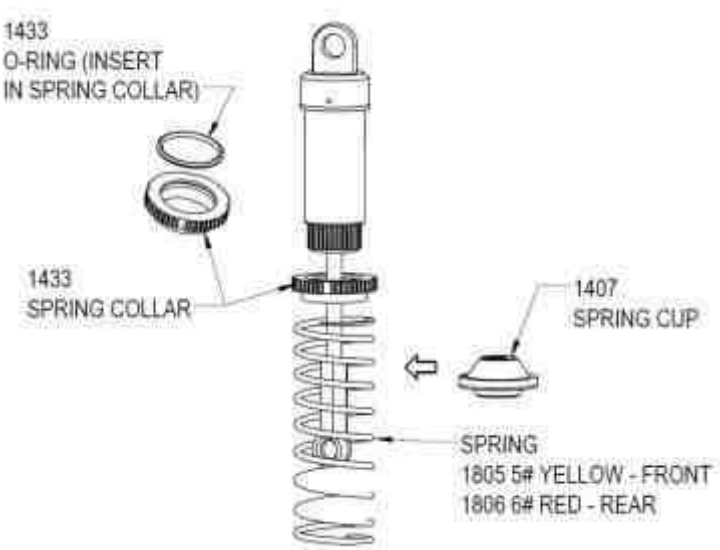

1433 O-RING (INSERT IN SPRING COLLAR)

1433 SPRING COLLAR

1407 SPRING CUP

SPRING
1805 5# YELLOW - FRONT
1806 6# RED - REAR

SET SPRING COLLARS AS SHOWN BELOW. THIS WILL GET THE RIDE HEIGHT CLOSE ON THE FINISHED CAR.

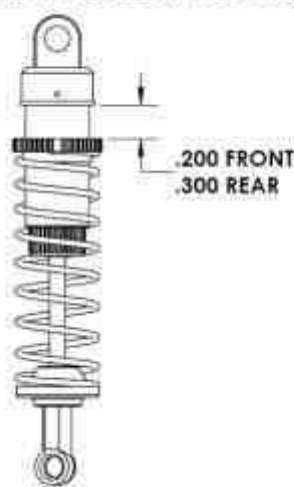

.200 FRONT
.300 REAR

Shock Mounting

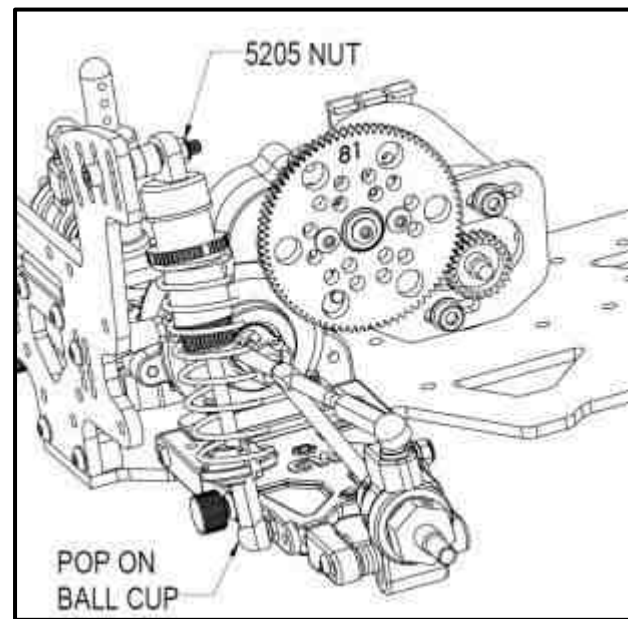
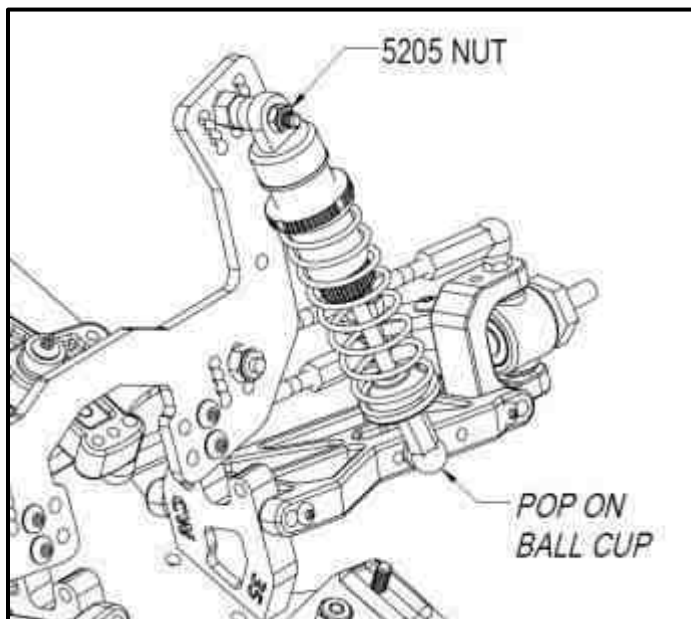
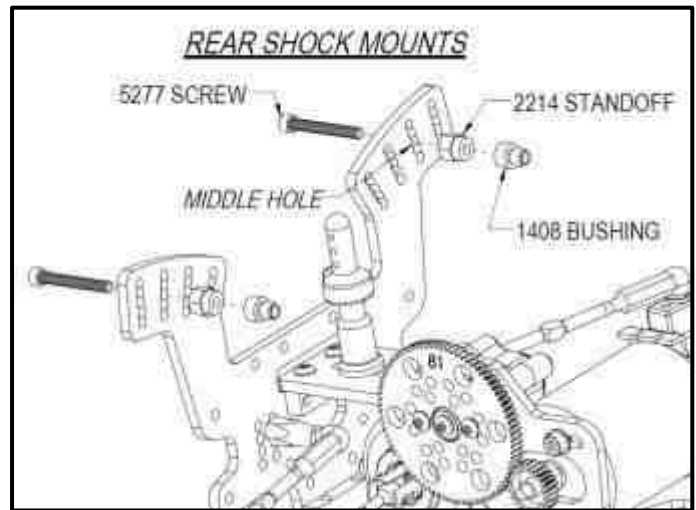
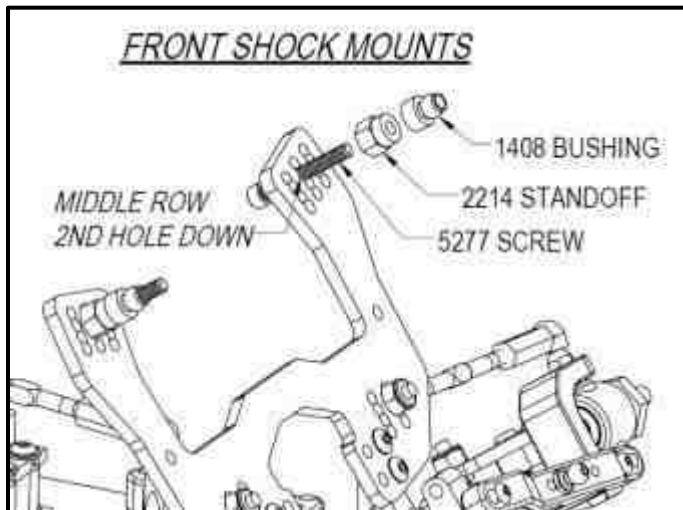

Electronics Mounting

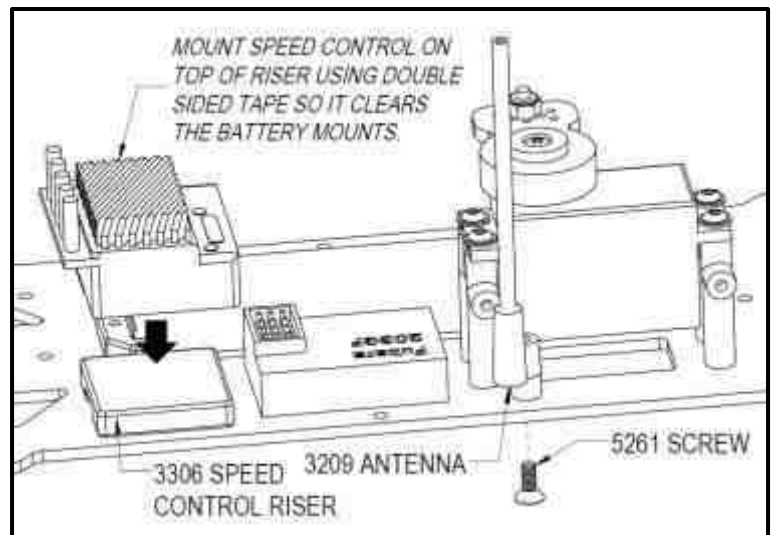
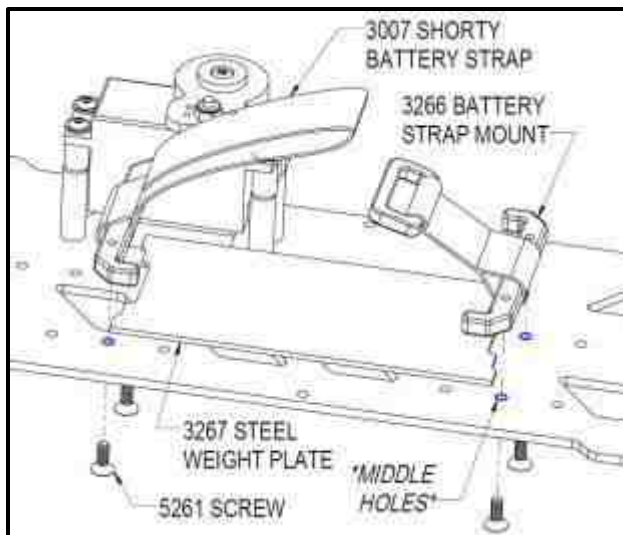

Cage Assembly

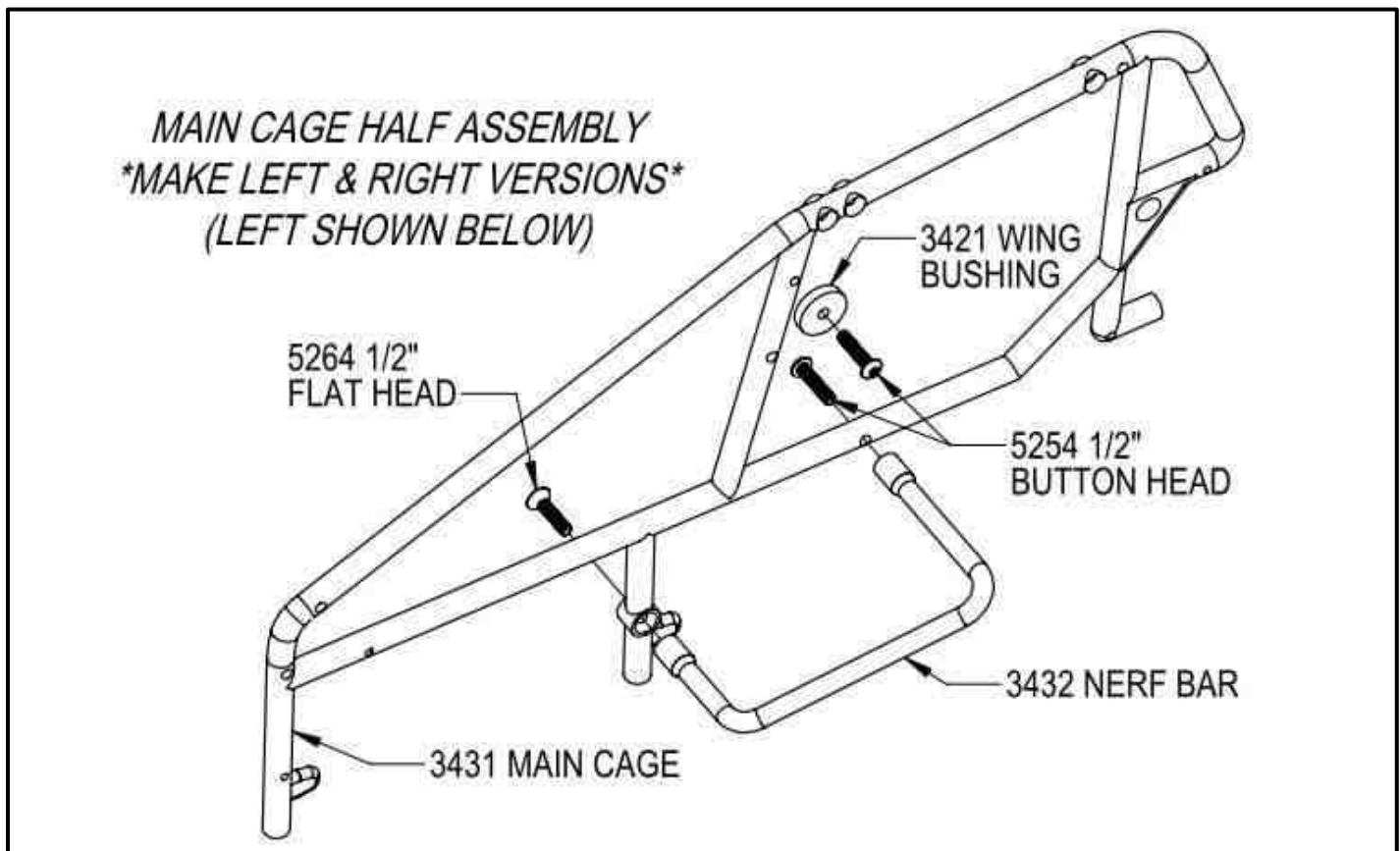
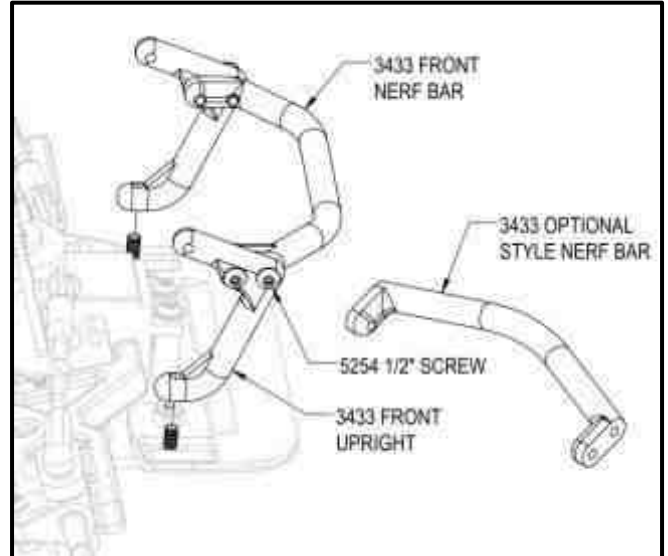
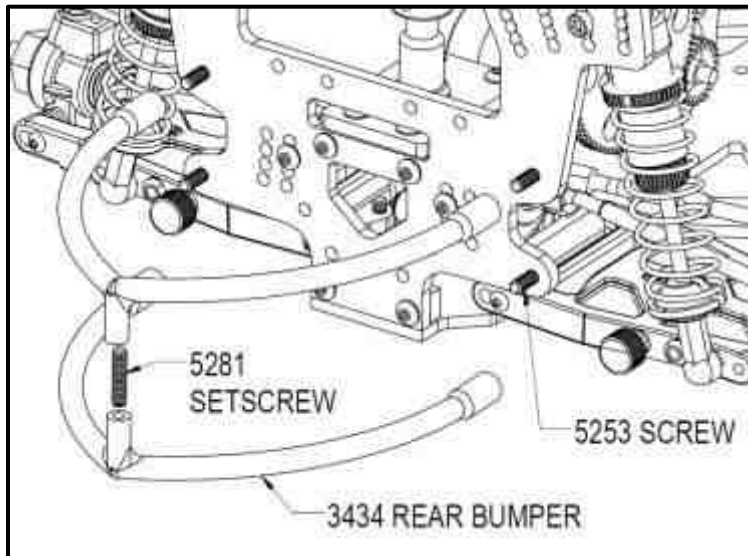

Cage Assembly continued

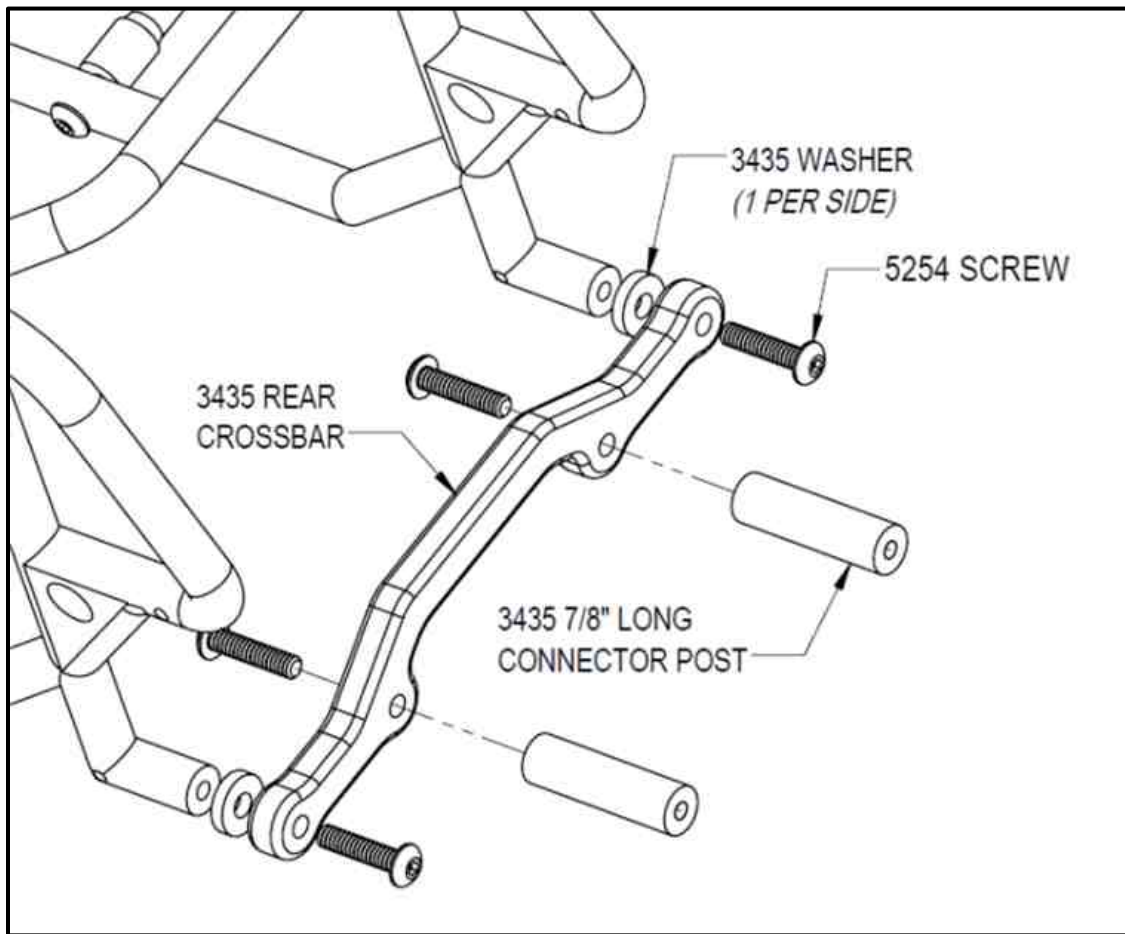
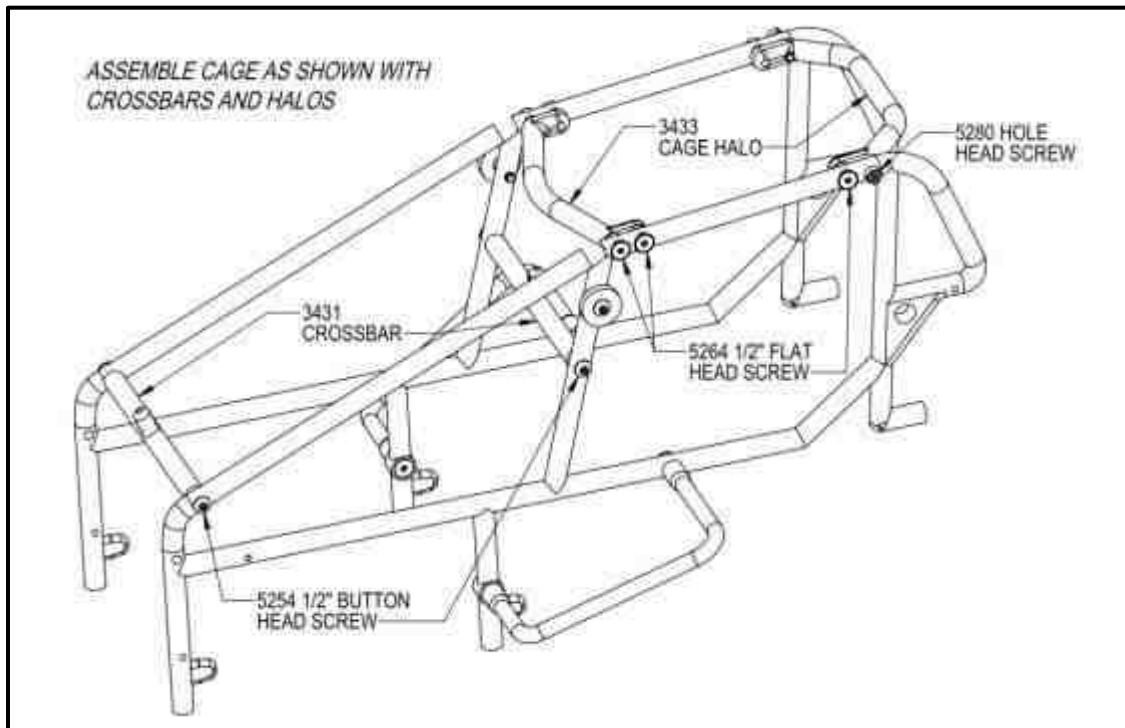

Cage Attachment

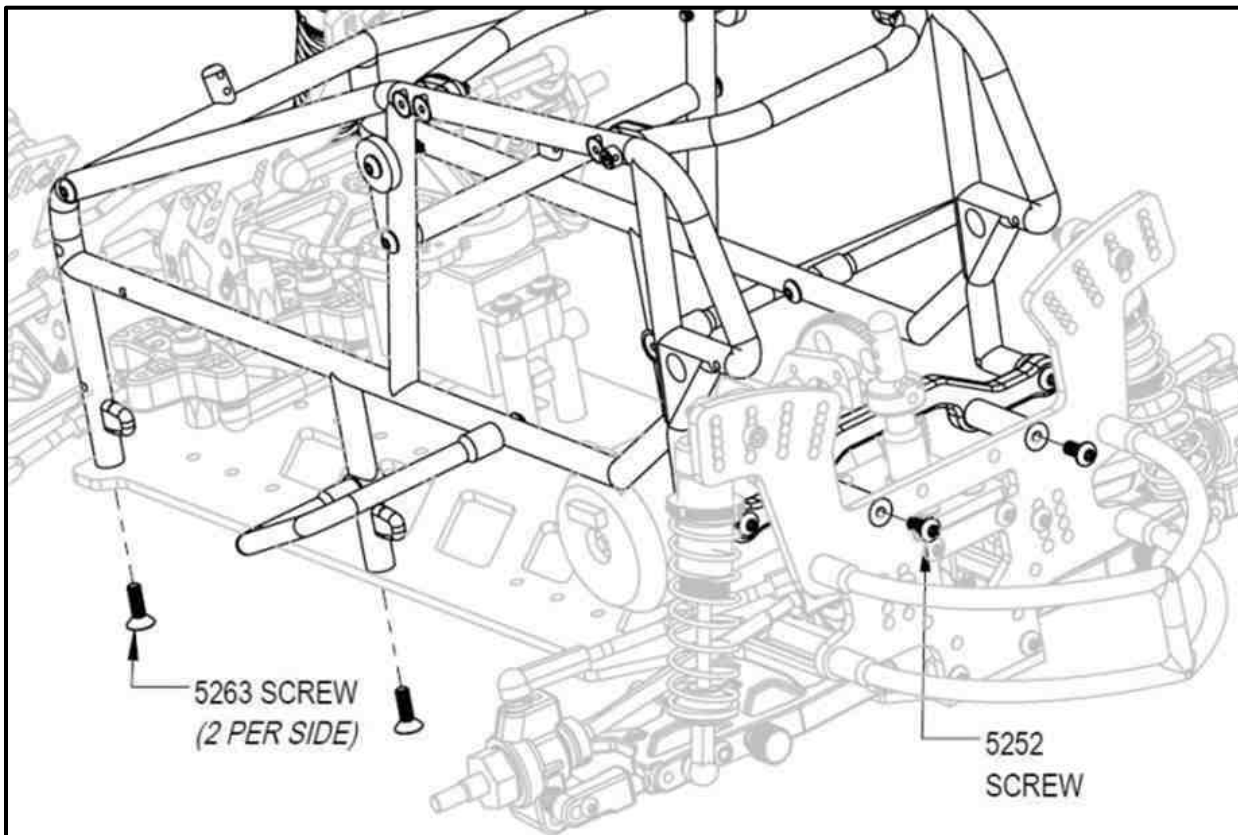

Body Assembly

Body pieces are shown painted for ease of viewing. Trim pieces and drill all holes BEFORE painting. On most pieces, a protective green film will keep overspray from getting on the outside of the body. Clean pieces with a mild detergent and dry before painting.

1. Hood – Cut on trim lines and drill 1/4" holes on (2) dimples front and back.



2. Nose piece – Cut as shown and drill 1/4" hole on the rear dimple as shown (do not follow trim lines).



2. Nose piece continued – Remove the front nerf bar and install the nose piece as shown. Mark the location of the 2 front nerf bar holes on each side and then drill with a .125 drill.

The optional low downforce nose piece can also be prepared in a similar manner.



3. Side panels – install side panels on the cage (you will have to remove some of the screws already installed).

The panel with the cockpit cutout goes on the left side of the car.



4. Headers – trim headers and drill (2) .125 mounting holes on each. Mount as shown using the inner header holes in the side panels.



5. Tail tank – drill a 1/4" hole on the forward dimple of the fuel fill area as shown. Trim the tank to clear the shock tower.



6. Top wing – build the top wing using the instructions included. Mount in the location shown on the cage.



7. Front wing – Assemble the frontwing and mount to the front nerf bar uprights as shown.



Congratulations! The assembly process is nearly complete. Install wheels and tires of your choice using the included wheel nuts.

Basic set-up – use the included turnbuckle wrench to fine tune the steering and camber links. Begin with a slight amount of toe-out on the front wheels. Make sure the servo saver is centered when the wheels are centered. Adjust the camber links so that all 4 tires lean to the left slightly (1 degree.)

Setup and Tuning

The standard build settings for the kit will provide a good starting point for an average "loose dirt" track. We've done our best to provide the racer with the best possible car, however it is the tuning of the car to the particular driver and track conditions that will make it a consistent winner. The following tuning tips can be used to dial the car into a specific track and situation. Each section is listed by order of importance.

1. Tires

Handling is the most important factor in dirt oval racing when it comes to lower lap times and winning races and at least 50% of handling is in the tires. Some racing tracks and organizations require a spec tire. Other tracks may allow any type of tire to be run. Regardless of the rules, it is important to choose the best option available for the track and conditions. Clean your tires with a mixture of Simple Green and water after running. For some tracks, breaking in the tires and/or adding a chemical prep can improve bite – the best advice is to ask another racer(s) who is fast at a track what works best. If tires are wearing out quickly, consider using a harder compound tire.

2. Shocks

If tires are 50% of handling, shocks are probably the next 30%. Now that you've done all the work to make a great set of tires, it's the shock's job to keep them on the track as much as possible. We've found the 6lb rear and 5lb front springs to be the best combination for this car and honestly we don't change them too often. Stiffer or softer springs can be used to achieve different results. Too stiff or too soft can quickly move the car's set up out of the ballpark, so test accordingly and go back to the stock springs if you are struggling. Another important adjustment in the shocks is the dampening which is controlled by the pistons and shock oil. The smaller the piston holes and the heavier the oil, the greater the dampening. Dampening requirements will vary from track to track depending on how bumpy the track is and the size and spacing of the bumps. If your car appears to be skidding as it enters a turn, you likely have too much dampening and should change to a lighter oil or larger hole piston. If the tires appear to be oscillating and bouncing, the problem is likely not enough dampening. Fix by using a smaller hole piston or heavier shock oil. Getting the dampening right for a given track will require some trial and error but is critical in keeping the tires on the ground allowing the car to accelerate and turn effectively. Try to use shock tuning to get the car through the bumps smoothly before attempting to use it to tighten or loosen the car.

3. Wing adjustment

The stock wing placement should be used as the starting point for most tracks. The wing can be moved into the farthest forward position on extremely high-bite tracks where rear bite is plentiful. When looking for more rear bite on a slick track, the wing should be moved toward the rear of the car. The wing angle can also be increased and will give the car a more "planted" feel but at the expense of aerodynamic drag.

4. Camber Links and Roll Centers

The hinge pin and camber link positions described in the kit instructions provide the standard roll center locations for this car. Both front and rear camber links can be shortened by using optional holes included. Shortening the camber links will cause the car to react quicker at the expense of stability. Front and rear can be adjusted independently to achieve the proper chassis balance for a given track condition.

Lowering the inner camber link location will raise the roll center and cause the chassis to roll less in corners. Less roll is generally better for conditions where traction is very high. Also be aware that lowering and/or shortening the camber links will increase camber gain as the suspension compresses.

5. Ride Height and Car Weight

The ride height is the distance between the track and the bottom of the chassis. For most loose dirt tracks the normal ride height should be 18mm in the rear and 17mm in the front. A little more ride height in the rear is usually good because the rear of the car will squat under acceleration. Ride height is adjusted with the various shock mounting holes provided on the car and fine-tuned using the threaded collars on the springs. Ride height can be lowered for extremely smooth high bite tracks, and can be raised if the chassis is bottoming out.

Weight in the form of brass or lead can be added to the car to make the car easier to drive on low bite or bumpy tracks. The added weight helps keep the tires pushed into the track. However adding weight will directly affect ride height by lowering the chassis, which is NOT what you want in this situation. So when adding weight, make sure you re-adjust the ride height.

6. Cross-weight

Cross-weight which is sometimes referred to as "wedge" can help tighten or loosen the car. Since oval racing consists only of left turns, there is less need to keep the weight of the car equally balanced between the left and right side tires. Increasing the spring tension on the left rear and right front shocks will add weight to those corners and make the car tighter. Doing the opposite will make it looser. Be careful not to go too far, excessive cross-weight can upset the ride height and not allow the suspension to work properly. A set of scales is required to measure cross-weight and should be measured on a level surface with the car as "ready to race" as possible.

7. Rear steer

Rear steer is created with the use of the adjustable rear arms. Because the car spends a great amount of time turning left, it is more efficient to have the rear tires help with the steering. The amount of rear steer needed largely depends on the track. Tighter turns require more rear steer. The most common setting is 4 degrees in on the left rear and 1 degree

in on the right rear. To help the car turn more, try 6 degrees in on the left and 1 degree out on the right. To make the car drive straighter try 3 degrees in on the left rear and 2 degrees in on the right rear. This is also a very easy adjustment to make before a race to quickly adapt to a changing track surface.

8. Droop

Droop is the distance the tires can drop before they lose contact with the track when the chassis is lifted. Droop can be limited by the use of the different shock mounting holes or with spacers inside the shocks. Limiting the droop in the front suspension will give the car more steering and limiting rear droop can provide more rear side bite. However a car with little or no droop will not handle the bumps in the track as well and can cause a car to be erratic. More droop works better on a low grip track and less droop works better on a high grip track.

9. Other adjustments

The adjustments above account for most of the changes needed to dial the car into a given track. Other adjustments are included in the car such as camber, Ackermann, wheelbase, front track, shock angle, etc. Even more option parts are available such as sway bars, optional caster blocks and front suspension mounts.

Please visit the Tech Center page at www.customworksrc.com for the full setup glossary and explanation of these options. Also you will find a PDF copy of this manual as well as blank set-up sheets and proven racer's set-ups.

Preventive Maintenance

RC cars have many moving parts which will wear over time. The normal wear of these parts as well as dirt from the track and occasional crashes require you to keep your car well maintained for optimal performance. Weekly maintenance should include:

- Remove and clean wheels and tires. Check wear and glue joints.
- Check for "gritty" ball bearings. Clean and re-lube or replace as needed.
- Remove shocks from the car, remove springs from the shocks and check for normal movement.
- With the tires and shocks removed, check suspension movement and make sure it moves freely but without too much slop. Even a small amount of binding caused by a bent pin, dirt, etc can cause erratic handling.
- Remove CVAs and check for excess slop or wear. Clean and re-lube.
- If differential is not smooth, sand or replace rings and rebuild. Make sure differential is not slipping on the track.
- Check for loose screws.
- Check for any bent or broken parts.



Driver: _____ Class: _____ Flat Banked Run Line: _____
 Track: _____ Driving Style: Smooth Surface: Smooth Bumpy
 Event: _____ Aggressive Traction: High Low

Tires

	Brand/Name	Compound	Insert
RF			
LF			
RR			
LR			

Cleaned With: _____
 Traction Additive: _____

Notes: _____

Shocks

	Body Length	Shaft Length	Spring	Oil	Piston	Shock Length	Collar	Spring Cup
RF	S M L	S M L			S M L			Sid. Ext.
LF	S M L	S M L			S M L			Sid. Ext.
RR	S M L	S M L			S M L			Sid. Ext.
LR	S M L	S M L			S M L			Sid. Ext.

Measure shock length with shocks on car and car not touching the ground.
 Go to lighter oil or larger piston if tires are skidding over bumps in track.
 Go to heavier oil or smaller piston if tires or car is bouncing.

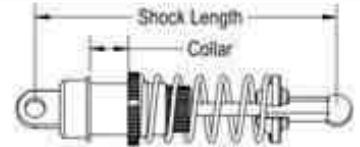

Ride Height

LF	RF
LR	RR

Max Chassis Height

LF	RF
LR	RR

Corner Weights

LF	RF
LR	RR

Rear %	
Left %	
Wedge %	

Measured From: Bottom of Chassis Top of Chassis

Total Weight: _____ Measured without wing

Front Suspension

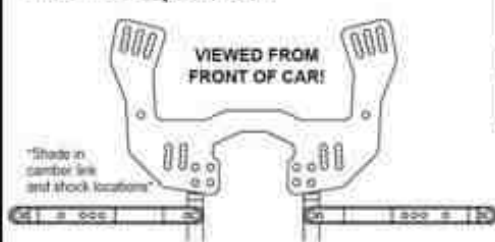

Kick-Up 25°
 35°
 Toe _____
 Sway Bar None

Right	Camber	Left	Right	Axle Shims	Left
<input type="checkbox"/> 0	Caster	<input type="checkbox"/> 0	<input type="checkbox"/> Inner	Ackermann	<input type="checkbox"/> Inner
<input type="checkbox"/> -5 <input type="checkbox"/> +5		<input type="checkbox"/> -5 <input type="checkbox"/> +5	<input type="checkbox"/> Middle		<input type="checkbox"/> Middle
<input type="checkbox"/> -10 <input type="checkbox"/> +10		<input type="checkbox"/> -10 <input type="checkbox"/> +10	<input type="checkbox"/> Outer		<input type="checkbox"/> Outer
<input type="checkbox"/> Inner	Kick-Up Location	<input type="checkbox"/> Inner	<input type="checkbox"/> Standard	Spindle	<input type="checkbox"/> Standard
<input type="checkbox"/> Outer		<input type="checkbox"/> Outer	<input type="checkbox"/> Trailing		<input type="checkbox"/> Trailing
<input type="checkbox"/> Inner	Outer Link Location	<input type="checkbox"/> Inner		Roll Center Shims	
<input type="checkbox"/> Kingpin		<input type="checkbox"/> Kingpin			

Rear Suspension



Outdrives / Diff. Steel
 Alum
 Gear

Left	Camber	Right	Left	Toe	Right
<input type="checkbox"/> 0	Spacers Behind Hub	<input type="checkbox"/> 0	<input type="checkbox"/> Inner	Outer Link Location	<input type="checkbox"/> Inner
<input type="checkbox"/> 1 <input type="checkbox"/> 2		<input type="checkbox"/> 1 <input type="checkbox"/> 2	<input type="checkbox"/> Outer		<input type="checkbox"/> Outer
<input type="checkbox"/> 3 <input type="checkbox"/> 4		<input type="checkbox"/> 3 <input type="checkbox"/> 4			
<input type="checkbox"/> None		<input type="checkbox"/> None			
<input type="checkbox"/> .060	Suspension Mount Shims	<input type="checkbox"/> .060	<input type="checkbox"/> None	Anti-Squat	<input type="checkbox"/> None
<input type="checkbox"/> .125		<input type="checkbox"/> .125	<input type="checkbox"/> 1.5°		<input type="checkbox"/> 1.5°
<input type="checkbox"/> Short	Suspension Mount	<input type="checkbox"/> Short	<input type="checkbox"/> 3°	Bottom Shock Hole	<input type="checkbox"/> 3°
<input type="checkbox"/> Long		<input type="checkbox"/> Long	<input type="checkbox"/> Inner		<input type="checkbox"/> Inner
<input type="checkbox"/> Upper	Hub Pin Location	<input type="checkbox"/> Upper	<input type="checkbox"/> Outer	Hex Offset	<input type="checkbox"/> Outer
<input type="checkbox"/> Lower		<input type="checkbox"/> Lower			

Top Wing:

6x6 7x7

Front Wing:

None Small Large

Nose:

Scoop Traditional

Top Wing Location:



Electronics

Motor: _____ Speed Control: _____
 Amp Draw: _____ Timing/Boost: _____
 Timing: _____ Drag Brake: _____
 Pinion: _____ Battery: _____
 Spur: _____ Battery Position: F M R

Notes:

