

1/8 LUXURY GT

# **XRAY GTX8**



**INSTRUCTION MANUAL**

**GTX8'22**

## BEFORE YOU START

This is a high-competition, high-quality RC car intended for persons aged 16 years and older with previous experience building and operating RC model racing cars. This is not a toy; it is a precision racing model. This model racing car is not intended for use by beginners, inexperienced customers, or by children without direct supervision of a responsible, knowledgeable adult. If you do not fulfill these requirements, please return the kit in unused and unassembled form back to the shop where you have purchased it.

Before building and operating your XRAY, **YOU MUST** read through all of the operating instructions and instruction manual and fully understand them to get the maximum enjoyment and prevent unnecessary damage. Read

carefully and fully understand the instructions before beginning assembly.

Make sure you review this entire manual, download and use set-up book from the web, and examine all details carefully. If for some reason you decide this is not what you wanted or expected, **do not continue any further**. Your hobby dealer can not accept your kit for return or exchange after it has been partially or fully assembled.

Contents of the box may differ from pictures. In line with our policy of continuous product development, the exact specifications of the kit may vary without prior notice.

## CUSTOMER SUPPORT

We have made every effort to make these instructions as easy to understand as possible. However, if you have any difficulties, problems, or questions, please do not hesitate to contact the XRAY support team at [info@teamxray.com](mailto:info@teamxray.com). Also, please visit our Web site at [www.teamxray.com](http://www.teamxray.com) to find the latest updates, set-up information, option parts, and many other goodies. We pride ourselves on taking excellent care of our customers.

You can join thousands of XRAY fans and enthusiasts in our online community at: **[www.teamxray.com](http://www.teamxray.com)**

### XRAY Europe

K Výstavisku 6992  
91101 Trenčín  
Slovakia, EUROPE  
Phone: +421-32-7401100  
Fax: +421-32-7401109  
Email: [info@teamxray.com](mailto:info@teamxray.com)

### XRAY USA

RC America, 2030 Century Center Blvd #15  
Irving, TX 75062  
USA  
Phone: (214) 744-2400  
Fax: (214) 744-2401  
Email: [xray@rcamerica.com](mailto:xray@rcamerica.com)

## FAILURE TO FOLLOW THESE INSTRUCTIONS WILL BE CONSIDERED AS ABUSE AND/OR NEGLECT.

## SAFETY PRECAUTIONS

**WARNING:** This product contains a chemical known to the state of California to cause cancer and birth defects or other reproductive harm.

**CAUTION: CANCER HAZARD**

Wash thoroughly after using. **DO NOT** use product while eating, drinking or using tobacco products. May cause chronic effects to gastrointestinal tract, CNS, kidneys, and blood. **MAY CAUSE BIRTH DEFECTS.**

When building, using and/or operating this model always wear protective glasses and gloves.

Take appropriate safety precautions prior to operating this model. You are responsible for this model's assembly and safe operation! Please read the instruction manual before building and operating this model and follow all safety precautions. Always keep the instruction manual at hand for quick reference, even after completing the assembly. Use only genuine and original authentic XRAY parts

for maximum performance. Using any third party parts on this model will void warranty immediately.

Improper operation may cause personal and/or property damage. XRAY and its distributors have no control over damage resulting from shipping, improper construction, or improper usage. XRAY assumes and accepts no responsibility for personal and/or property damages resulting from the use of improper building materials, equipment and operations. By purchasing any item produced by XRAY, the buyer expressly warrants that he/she is in compliance with all applicable federal, state and local laws and regulation regarding the purchase, ownership and use of the item. The buyer expressly agrees to indemnify and hold harmless XRAY for all claims resulting directly or indirectly from the purchase, ownership or use of the product. By the act of assembling or operating this product, the user accepts all resulting liability. If the buyer is not prepared to accept this liability, then he/she should return this kit in new, unassembled, and unused condition to the place of purchase.

## IMPORTANT NOTES - GENERAL

- This product is not suitable for children under 16 years of age without the direct supervision of a responsible and knowledgeable adult.
- Carefully read all manufacturers warnings and cautions for any parts used in the construction and use of your model.
- Assemble this kit only in places away from the reach of very small children.
- First-time builders and users should seek advice from people who have building experience in order to assemble the model correctly and to allow the model to reach its performance potential.
- Exercise care when using tools and sharp instruments.
- Take care when building, as some parts may have sharp edges.
- Keep small parts out of reach of small children. Children must not be allowed to put any parts in their mouth, or pull vinyl bag over their head.
- Read and follow instructions supplied with paints and/or cement, if used (not included in kit).
- Immediately after using your model, do NOT touch equipment on the model such as the motor and speed controller, because they generate high temperatures. You may seriously burn yourself seriously touching them.
- Follow the operating instructions for the radio equipment at all times.
- Do not put fingers or any objects inside rotating and moving parts, as this may cause damage or serious injury as your finger, hair, clothes, etc. may get caught.
- Be sure that your operating frequency is clear before turning on or running your model, and never share the same frequency with somebody else at the same time. Ensure that others are aware of the operating frequency you are using and when you are using it.
- Use a transmitter designed for ground use with RC cars. Make sure that no one else is using the same frequency as yours in your operating area. Using the same frequency at the same time, whether it is driving, flying or sailing, can cause loss of control of the RC model, resulting in a serious accident.
- Always turn on your transmitter before you turn on the receiver in the car. Always turn off the receiver before turning your transmitter off.
- Keep the wheels of the model off the ground when checking the operation of the radio equipment.
- Disconnect the battery pack before storing your model.
- When learning to operate your model, go to an area that has no obstacles that can damage your model if your model suffers a collision.
- Remove any sand, mud, dirt, grass or water before putting your model away.
- If the model behaves strangely, immediately stop the model, check and clear the problem.
- To prevent any serious personal injury and/or damage to property, be responsible when operating all remote controlled models.
- The model car is not intended for use on public places and roads or areas where its operation can conflict with or disrupt pedestrian or vehicular traffic.
- Because the model car is controlled by radio, it is subject to radio interference from many sources that are beyond your control. Since radio interference can cause momentary loss of control, always allow a safety margin in all directions around the model in order to prevent collisions.
- Do not use your model:
  - Near real cars, animals, or people that are unaware that an RC car is being driven.
  - In places where children and people gather
  - In residential districts and parks
  - In limited indoor spaces
  - In wet conditions
  - In the street
  - In areas where loud noises can disturb others, such as hospitals and residential areas.
  - At night or anytime your line of sight to the model may be obstructed or impaired in any way.

To prevent any serious personal injury and/or damage to property, please be responsible when operating all remote controlled models.

## IMPORTANT NOTES - NITRO ENGINES

- Always test the brakes and the throttle before starting your engine to avoid losing control of the model.
- Make sure the air filter is clean and oiled.
- Never run your engine without an air filter. Your engine can be seriously damaged if dirt and debris get inside the engine.
- For proper engine break-in, please refer to the manual that came with the engine.
- Do not run near open flames or smoke while running your model or while handling fuel.
- Some parts will be hot after operation. Do not touch the exhaust or the engine until they have cooled. These parts may reach 275°F during operation!

## **IMPORTANT NOTES - ELECTRICAL**

- Insulate any exposed electrical wiring (using heat shrink tubing or electrical tape) to prevent dangerous short circuits. Take maximum care in wiring, connecting and insulating cables. Make sure cables are always connected securely. Check connectors for if they become loose. And if so, reconnect them securely. Never use R/C models with damaged wires. A damaged wire is extremely dangerous, and can cause short-circuits resulting in fire. Please have wires repaired at your local hobby shop.
- Low battery power will result in loss of control. Loss of control can occur due to a weak battery in either the transmitter or the receiver. Weak running battery may also result in an out of control car if your car's receiver power is supplied by the running battery. Stop operation immediately if the car starts to slow down.
- When not using RC model, always disconnect and remove battery.
- Do not disassemble battery or cut battery cables. If the running battery short-circuits, approximately 300W of electricity can be discharged, leading to fire or burns. Never disassemble battery or cut battery cables.
- Use a recommended charger for the receiver and transmitter batteries and follow the instructions correctly. Over-charging, incorrect charging, or using

inferior chargers can cause the batteries to become dangerously hot. Recharge battery when necessary. Continual recharging may damage battery and, in the worst case, could build up heat leading to fire. If battery becomes extremely hot during recharging, please ask your local hobby shop for check and/or repair and/or replacement.

- Regularly check the charger for potential hazards such as damage to the cable, plug, casing or other defects. Ensure that any damage is rectified before using the charger again. Modifying the charger may cause short-circuit or overcharging leading to a serious accident. Therefore do not modify the charger.
- Always unplug charger when recharging is finished.
- Do not recharge battery while battery is still warm. After use, battery retains heat. Wait until it cools down before charging.
- Do not allow any metal part to short circuit the receiver batteries or other electrical/electronic device on the model.
- Immediately stop running if your RC model gets wet as may cause short circuit.
- Please dispose of batteries responsibly. Never put batteries into fire.

## **IMPORTANT NOTES - NITRO FUEL**

- Handle fuel only outdoors. Never handle nitro fuel indoors, or mix nitro fuel in a place where ventilation is bad.
- Only use nitro fuel for R/C models. Do not use gasoline or kerosene in R/C models as it may cause a fire or explosion, and ruin your engine.
- Nitro fuel is highly flammable, explosive, and poisonous. Never use fuel indoors or in places with open fires and sources of heat.
- Always keep the fuel container cap tightly shut.
- Always read the warning label on the fuel container for safety information.
- Nitro-powered model engines emit poisonous vapors and gasses. These vapors irritate eyes and can be highly dangerous to your health. We recommend wearing rubber or vinyl gloves to avoid direct contact with nitro fuel.
- Nitro fuel for RC model cars is made of the combination of the methyl alcohol,

castor or synthetic oil, nitro methane etc. The flammability and volatility of these elements is very high, so be very careful during handling and storage of nitro fuel.

- Keep nitro fuel away from open flame, sources of heat, direct sunlight, high temperatures, or near batteries.
- Store fuel in a cool, dry, dark, well-ventilated place, away from heating devices, open flames, direct sunlight, or batteries. Keep nitro fuel away from children.
- Do not leave the fuel in the carburetor or fuel tank when the model is not in use. There is danger that the fuel may leak out.
- Wipe up any spilled fuel with a cloth.
- Be aware of spilled or leaking fuel. Fuel leaks can cause fires or explosions.
- Do not dispose of fuel or empty fuel containers in a fire. There is danger of explosion.

## **R/C & BUILDING TIPS**

- Make sure all fasteners are properly tightened. Check them periodically.
- Make sure that chassis screws do not protrude from the chassis.
- For the best performance, it is very important that great care is taken to ensure the free movement of all parts.
- Clean all ball-bearings so they move very easily and freely.
- Tap or pre-thread the plastic parts when threading screws.
- Self-tapping screws cut threads into the parts when being tightened. Do not use excessive force when tightening the self-tapping screws because you may strip out the thread in the plastic. We recommended you stop tightening a screw when you feel some resistance.

- Ask your local hobby shop for any advice.

Please support your local hobby shop. We at XRAY Model Racing Cars support all local hobby dealers. Therefore we ask you, if at all possible, to purchase XRAY products at your hobby dealer and give them your support like we do. If you have difficulty finding XRAY products, please check out [www.teamxray.com](http://www.teamxray.com) to get advice, or contact us via email at [info@teamxray.com](mailto:info@teamxray.com), or contact the XRAY distributor in your country.

## **WARRANTY**

XRAY guarantees this model kit to be free from defects in both material and workmanship within 30 days of purchase. The total monetary value under warranty will in no case exceed the cost of the original kit purchased. This warranty does not cover any components damaged by use or modification or as a result of wear. Part or parts missing from this kit must be reported within 30 days of purchase. No part or parts will be sent under warranty without proof of purchase. Should you find a defective or missing part, contact the local distributor. Service and customer support will be provided through local hobby store where you have purchased the kit, therefore make sure to purchase any XRAY products at your local hobby store. This model racing car is considered to be a high-performance racing vehicle. As such this vehicle will be used in an extreme range of conditions and situations, all which may cause premature wear or failure of any component. XRAY has no control over usage of vehicles once they leave the dealer, therefore XRAY can only offer warranty against all manufacturer's defects in materials, workmanship, and assembly at point of sale and before use. No warranties are expressed or implied that cover damage caused by what is considered normal use, or cover or imply how long any model cars' components or electronic components will last before requiring replacement.

Due to the high performance level of this model car you will need to periodically maintain and replace consumable components. Any and all warranty coverage will not cover replacement of any part or component damaged by neglect, abuse, or improper or unreasonable use. This includes but is not limited to damage from

crashing, chemical and/or water damage, excessive moisture, improper or no maintenance, or user modifications which compromise the integrity of components. Warranty will not cover components that are considered consumable on RC vehicles. XRAY does not pay nor refund shipping on any component sent to XRAY or its distributors for warranty. XRAY reserves the right to make the final determination of the warranty status of any component or part.

### **Limitations of Liability**

XRAY makes no other warranties expressed or implied. XRAY shall not be liable for any loss, injury or damages, whether direct, indirect, special, incidental, or consequential, arising from the use, misuse, or abuse of this product and/or any product or accessory required to operate this product. In no case shall XRAY's liability exceed the monetary value of this product.

**Take adequate safety precautions prior to operating this model. You are responsible for this model's assembly and safe operation.**

**Disregard of the any of the above cautions may lead to accidents, personal injury, or property damage. XRAY MODEL RACING CARS assumes no responsibility for any injury, damage, or misuse of this product during assembly or operation, nor any addictions that may arise from the use of this product. All rights reserved.**

XRAY MODEL RACING CARS uses only the highest quality materials, the best compounds for molded parts and the most sophisticated manufacturing processes of TQM (Total Quality Management). We guarantee that all parts of a newly-purchased kit are manufactured with the highest regard to quality. However, due to the many factors inherent in model racecar competition, we cannot guarantee any

parts once you start racing the car. Products which have been worn out, abused, neglected or improperly operated will not be covered under warranty. We wish you enjoyment of this high-quality and high-performance RC car and wish you best success on the track!

**In line with our policy of continuous product development, the exact specifications of the kit may vary. In the unlikely event of any problems with your new kit, you should contact the model shop where you purchased it, quoting the part number. We do reserve all rights to change any specification without prior notice. All rights reserved.**

# TOOLS REQUIRED

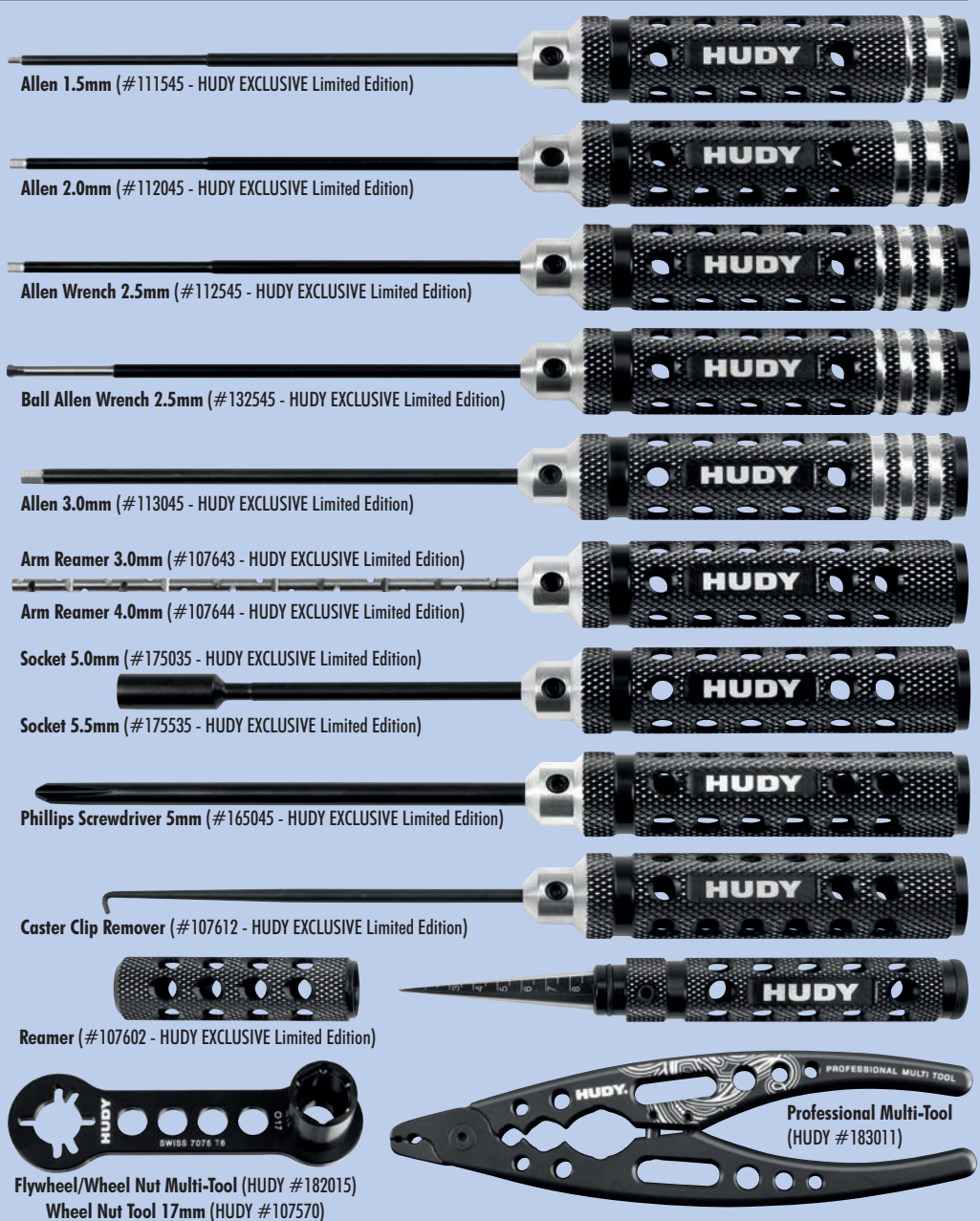

# EQUIPMENT REQUIRED



# EQUIPMENT INCLUDED \* Kit includes smaller but sufficient amount of oil and grease to build the car.

800cSt (#106381)  
HUDY Premium Silicone Oils



50.000cSt (#106551)  
HUDY Premium Silicone Oils



300.000cSt (#106631)  
HUDY Premium Silicone Oils



(HUDY #106210)  
Premium Graphite Grease



At the beginning of each section is an exploded view of the parts to be assembled. There is also a list of all the parts and part numbers that are related to the assembly of that section. The part descriptions are color-coded to make it easier for you to identify the source of a part. Here are what the different colors mean:

STYLE A - indicates parts that are included in the bag marked for the section.

STYLE B - indicates parts that are included in the box.

STYLE C - indicates parts that are already assembled from previous steps.

## GTX TECH TIPS

### TIP FRONT & REAR DIFF GEAR MESH ADJUSTMENT

If there is too much or too little diff side play, this may create non-optimal gear mesh between the diff gear and the pinion drive gear. This is easily resolved by inserting 1 or 2 of the included thin shims behind a diff outdrive ball-bearing, depending on how much play there is.

THE LOCATION OF THE SHIM(S) DEPENDS ON WHETHER YOU ARE TRYING TO CLOSE OR OPEN THE GAP:

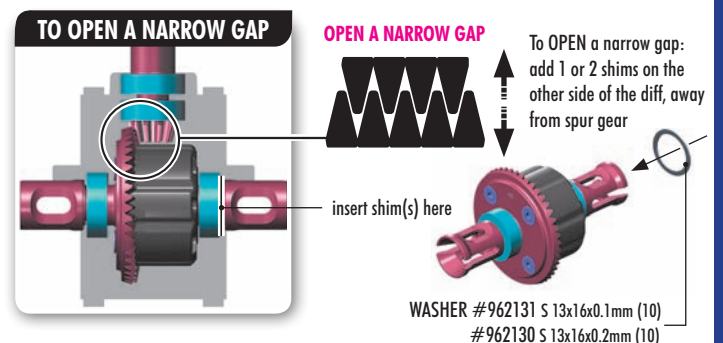
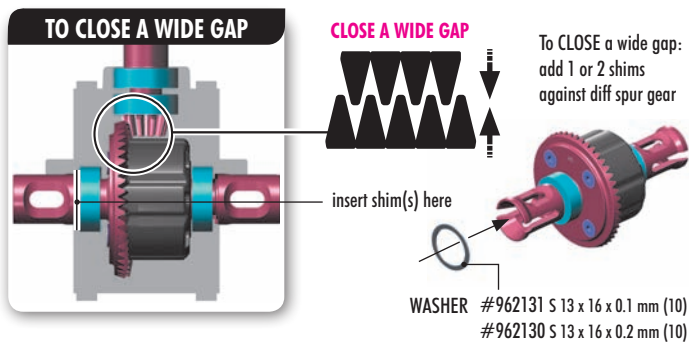

**CHECK GEAR MESH AND DIFF PLAY ONLY AFTER THE ENTIRE GEARBOX IS MOUNTED TOGETHER WITH THE SUSPENSION HOLDERS ON THE CHASSIS. ALL PARTS ARE DESIGNED TO HAVE CERTAIN PLAY AND IT IS ALL DESIGNED BY PURPOSE.**

### SUSPENSION & DRIVETRAIN MAINTENANCE

- Check suspension for free movement during building and operation, and especially after running and if you have crashed the car. If the suspension does not move freely, use the appropriate HUDY Arm Reamer to clean and resize the holes of the suspension arms.
- Regularly check the drive shaft pins (both side and center) and if they show any wear must be immediately replaced by new pins. If the car is run with worn pins, excessive wear on the diff outdrives will result. The 106000 HUDY Drive Pin Replacement Tool (for 3mm Pins) is a compact, rugged multi-use tool set for replacing 3mm drive pins in drive shafts. Use the HUDY replacement drive shaft pins 3x14 (#106050).

### HUDY SPRING STEEL™

The HUDY Spring Steel™ used in the car is the strongest and most durable steel material on the RC market. While items made from HUDY Spring Steel™ are still subject to wear, the lifespan is considerably longer than any other material. As parts made from HUDY Spring Steel™ wear, the brown color will after some time "go down" but it will not affect the strength of the material. The brown color is only a surface treatment and if the brown color will wear the durability of the part will be still strong.

- Regularly inspect and replace the connecting pins which connect the center drive shafts with the pinion gear, and also the pins that connect the wheel drive shafts with wheel axles. Use HUDY Graphite Grease to lubricate the drive shaft connecting joints and the diff gears.
- Pivot balls and ball-joints will naturally wear for some time and will generate play. If there is too much play the pivot balls and ball joints need to be replaced.
- If the car is run in wet conditions, apply WD-40® on all drivetrain parts before the run. After the run, clean and dry the parts again.

### TIP DRIVE SHAFT PIN SERVICING

To enjoy the longest possible lifespan of the drive shafts and diff outdrives, it is extremely important to properly service the drive shaft pins. Inspect the pins after every 3 hours of runtime. If the pins show any wear, replace them with new pins.



# 1. DIFFERENTIALS



## XRAY BALL-BEARING

OPTION	#930816	8x16x5	GREASE	STEEL	OPTION
	#930817	8x16x5	OIL	STEEL	OPTION
	#940816	8x16x5	GREASE	RUBBER	OPTION
	#940817	8x16x5	OIL	RUBBER	INCLUDED



# 355064  
FRONT DIFF. OUTDRIVE ADAPTER  
LONG - V2 - HSS™ (2)

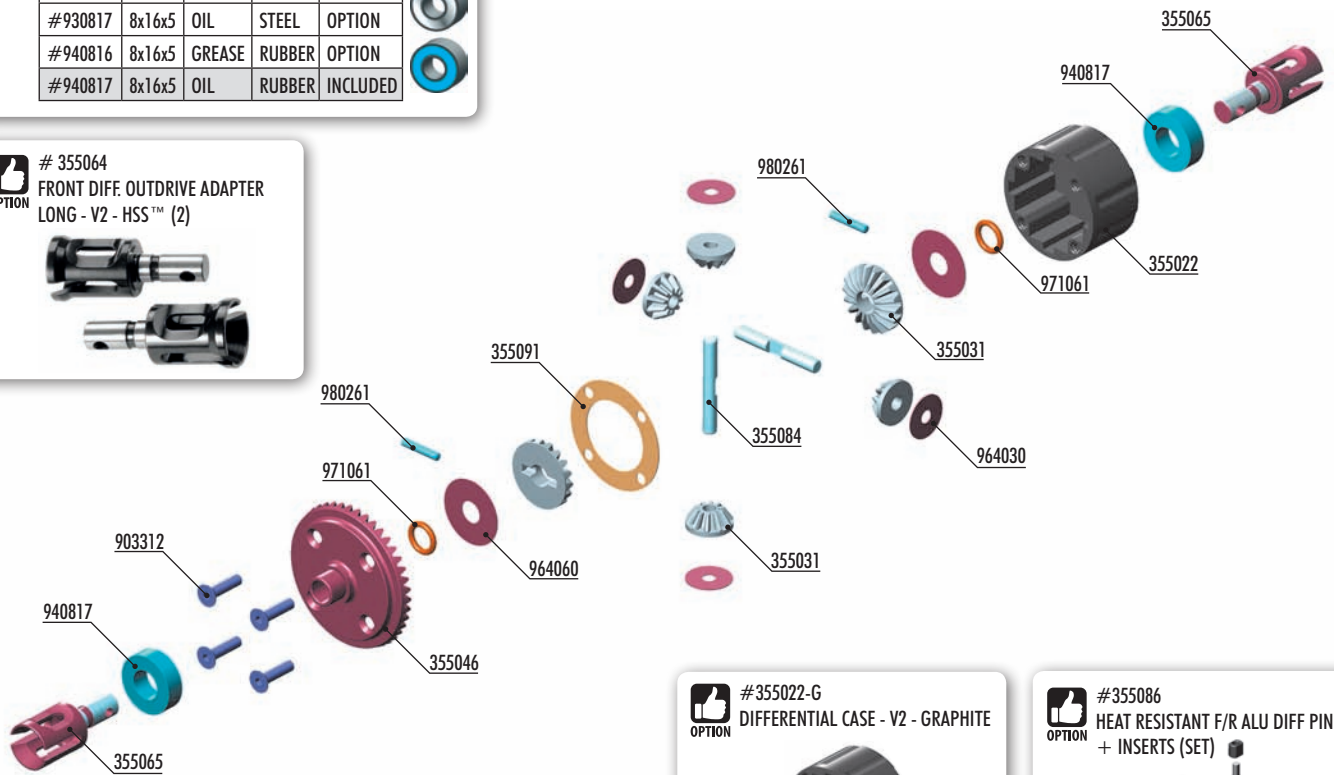

#355022-G  
DIFFERENTIAL CASE - V2 - GRAPHITE



#355086  
HEAT RESISTANT F/R ALU DIFF PIN  
+ INSERTS (SET)



- 355005 DIFFERENTIAL 46T - V2 - SET
- 355022 DIFFERENTIAL CASE - V2
- 355031 STEEL DIFF BEVEL & SATELLITE GEARS - V2 (2+4)
- 355046 FRONT/REAR DIFF LARGE BEVEL GEAR 46T - HUDY STEEL
- 355065 DIFF OUTDRIVE ADAPTER - V2 - HUDY SPRING STEEL™ (2)
- 355084 F/R DIFF PIN (2)
- 355091 F/R DIFF GASKET (4)

- 903312 HEX SCREW SFH M3x12 (10)
- 940817 BALL-BEARING 8x16x5 RUBBER SEALED - OIL (2)
- 964030 WASHER S 3.5x12x0.2 (10)
- 964060 WASHER S 6x18x0.2 (10)
- 971061 SILICONE O-RING 6x1.55 (10)
- 980261 PIN 2.5x11.5 (10)

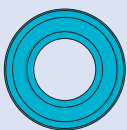

940817  
BB 8x16x5



964060  
S 6x18x0.2



971061  
O 6x1.55

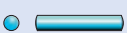

980261  
P 2x11.6

2x  
F=R

**TIP** Use HUDY Ball-Bearing Grease or Oil for servicing:  
#106220 - Standard  
#106221 - Extra  
#106222 - Premium  
#106230 - Bearing Oil

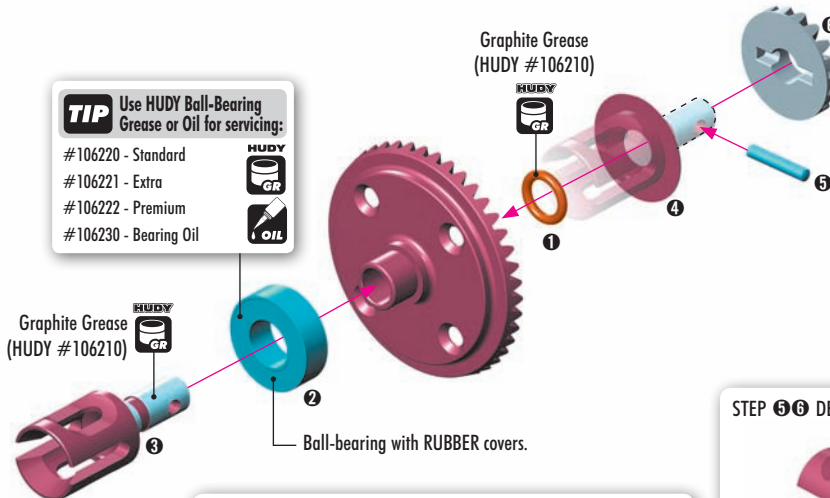

Graphite Grease (HUDY #106210)

Ball-bearing with RUBBER covers.

Graphite Grease (HUDY #106210)

STEP 5-6 DETAIL

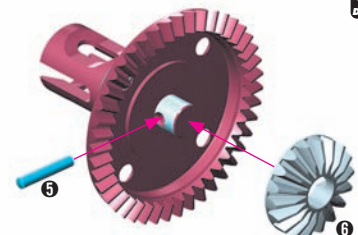





## XRAY BALL-BEARING

OPTION	#930816	8x16x5	GREASE	STEEL	OPTION
	#930817	8x16x5	OIL	STEEL	OPTION
	#940816	8x16x5	GREASE	RUBBER	OPTION
	#940817	8x16x5	OIL	RUBBER	INCLUDED



**SET-UP BOOK**  
DIFFERENTIAL GEARS

-  940817  
BB 8x16x5
-  964060  
S 6x18x0.2
-  971061  
O 6x1.55
-  980212  
P 2x11.6

**2x**

**F=R**

Graphite Grease (HUDY #106210)

Ball-bearing with RUBBER covers.

Graphite Grease (HUDY #106210)

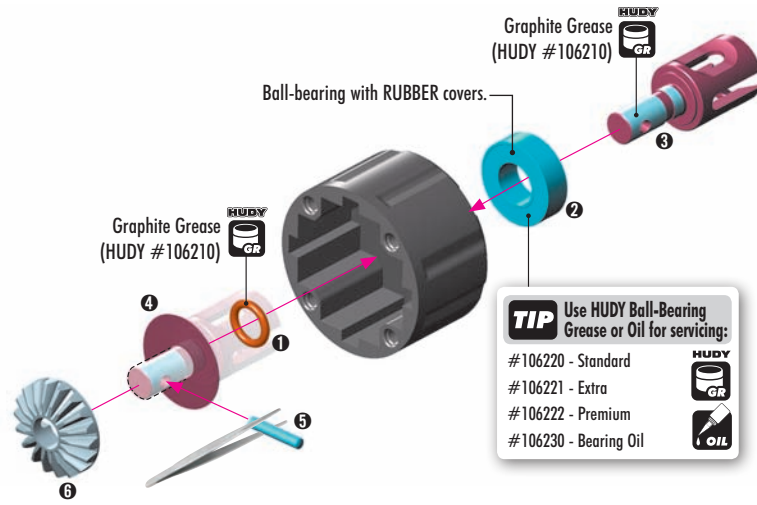

**TIP** Use HUDY Ball-Bearing Grease or Oil for servicing:

- #106220 - Standard
- #106221 - Extra
- #106222 - Premium
- #106230 - Bearing Oil

**STEP 6 DETAIL**

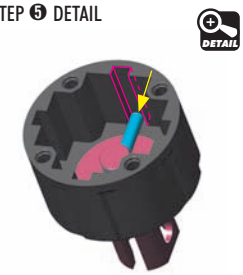

-  903312  
SFH M3x12
-  964030  
S 3.5x12x0.2

**VERY IMPORTANT!**

Use the following silicone oils included in the kit for initial settings:  
FRONT diff: 300.000cSt / REAR diff: 50.000cSt

**CORRECT** ✓

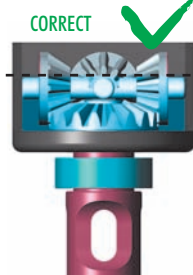

Fill the differentials with oil just above the satellite gears.

**INCORRECT** ✗



**IMPORTANT!**

Do not overfill the differential. If there is too much oil in the differential, it may leak after it cools down after use.

**To ensure you have the same amount of oil from rebuild to rebuild, do the following:**

#107865 HUDY Ultimate Digital Pocket Scale 300g ± 0.01g



FRONT 39.10 g  
REAR 39.10 g



FRONT 41.10 g  
REAR 41.10 g

1. Put the diff (without oil) on the scale and check the weight:  
- FRONT DIFF approx. 39.10g  
- REAR DIFF approx. 39.10g
2. Slowly pour oil into the diff and watch the weight. The approximate weight of the diff+oil is REAR DIFF approx. 41.10g and FRONT DIFF approx. 41.10g

**REAR DIFF** 39.10g + 2.0g = 41.10g

**FRONT DIFF** 39.10g + 2.0g = 41.10g

**Front diff:**  
Silicone oil 300.000cSt  
Fill just above the satellite gears.

**Rear diff:**  
Silicone oil 50.000cSt  
Fill just above the satellite gears.

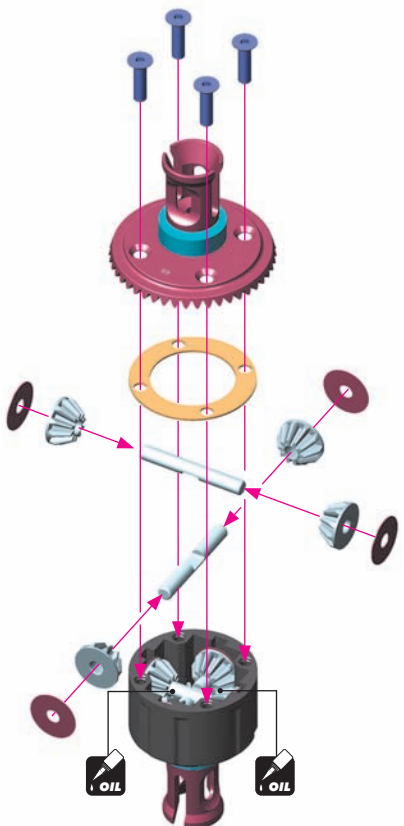

**SET-UP BOOK**

DIFFERENTIAL OIL

Tighten the screws equally.



Finish tightening in this order.

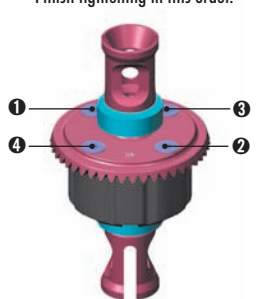

After assembly the differentials should have a length of 32.3~32.5 mm measured from the ends of the installed ball-bearings. If differentials are longer, retighten the 4 screws holding the crown gears.

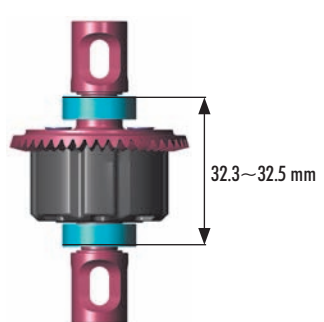

## 2. FRONT & REAR TRANSMISSION

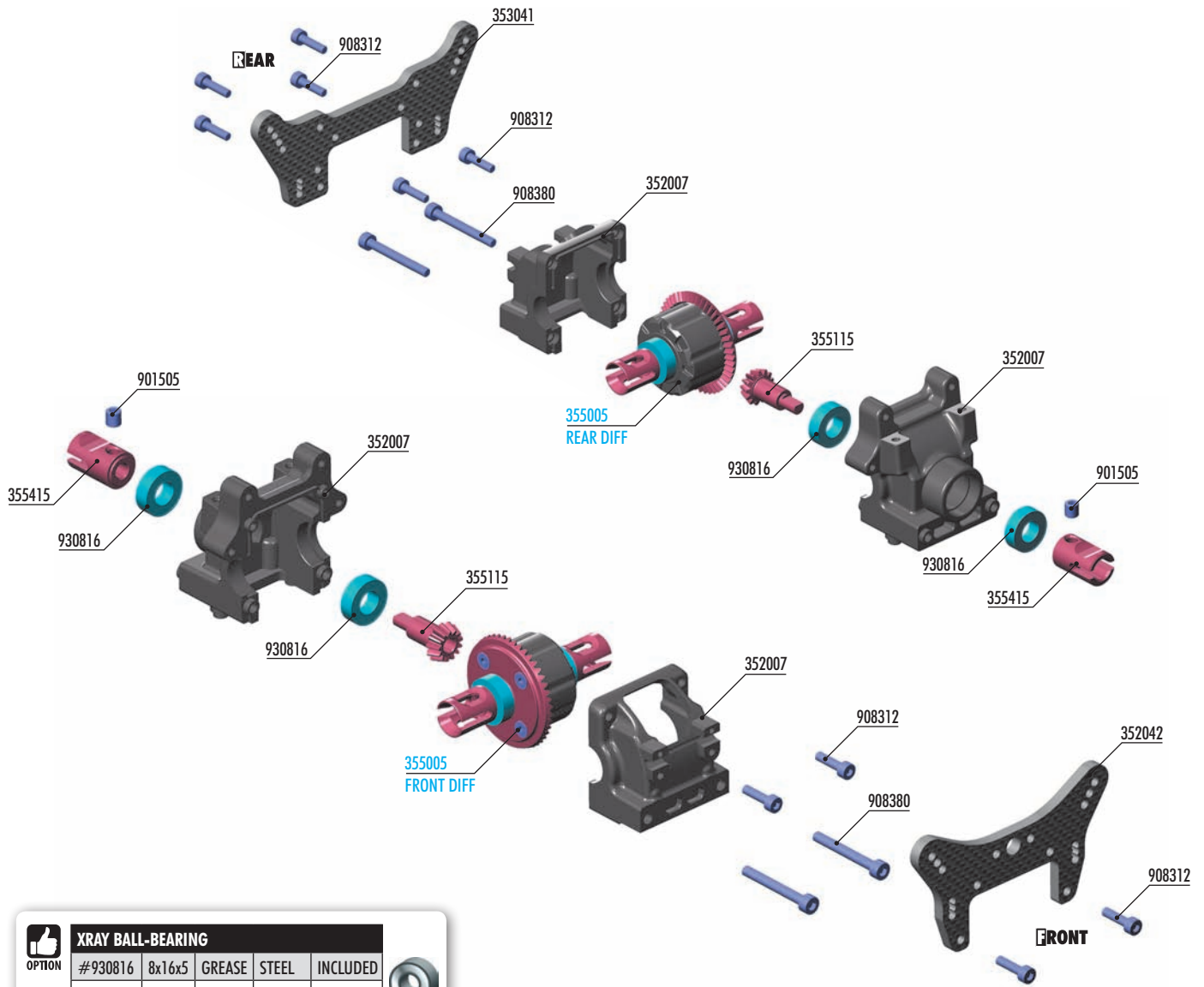

**BAG**

**02**

352007 DIFF BULKHEAD BLOCK WITH AIR COOLING SET FRONT/REAR  
 352042 GRAPHITE FRONT SHOCK TOWER 4MM  
 353041 GRAPHITE REAR SHOCK TOWER 4MM  
 355115 BEVEL DRIVE GEAR 13T  
 355415 CENTRAL DOGBONE SHAFT UNIVERSAL JOINT - HUDY SPRING STEEL™ (2)

901505 HEX SCREW SB M5x5 (10)  
 908312 HEX SCREW SOCKET HEAD CAP SCH M3x12 (10)  
 908380 HEX SCREW SOCKET HEAD CAP M3.5x30 - STAINLESS (10)  
 930816 BALL-BEARING 8x16x5 STEEL SEALED - GREASE (2)

355005 DIFFERENTIAL 46T - V2 - SET

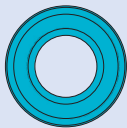

930816  
BB 8x16x5



901505  
SB M5x5

**2x**



Apply a drop of bearing oil after every 2-3 hours of driving to increase the life time. Dry bearing can overheat and damage the bulkhead.

**TIP** Use HUDY Ball-Bearing Grease or Oil for servicing:

#106220 - Standard  
 #106221 - Extra  
 #106222 - Premium  
 #106230 - Bearing Oil



Ball-bearing with STEEL covers



XRAY BALL-BEARING					
OPTION	#930816	8x16x5	GREASE	STEEL	INCLUDED
	#930817	8x16x5	OIL	STEEL	OPTION

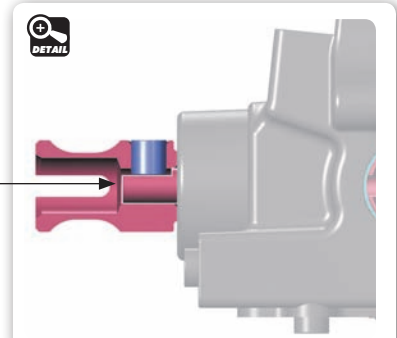



## 2. FRONT & REAR TRANSMISSION

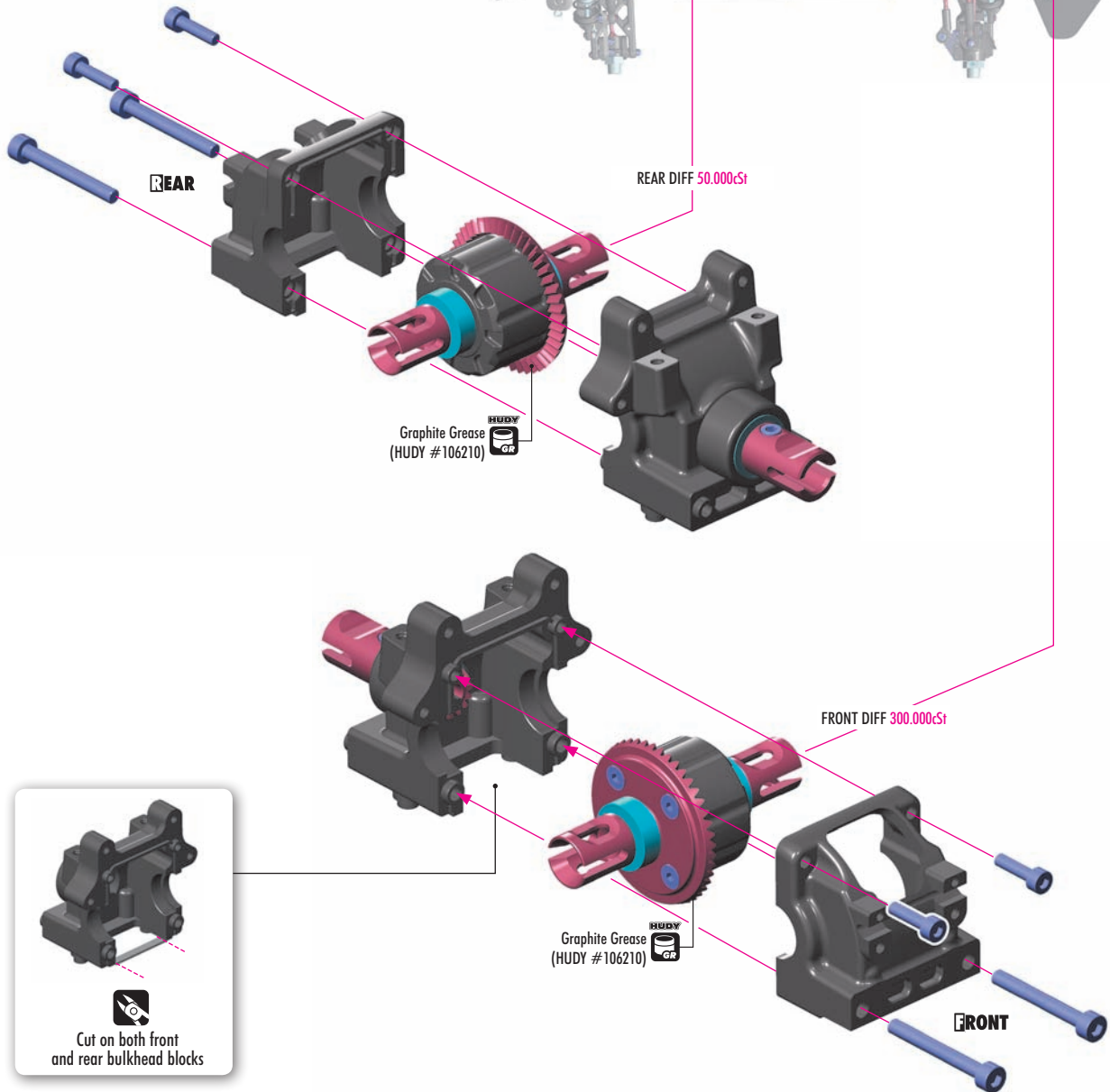
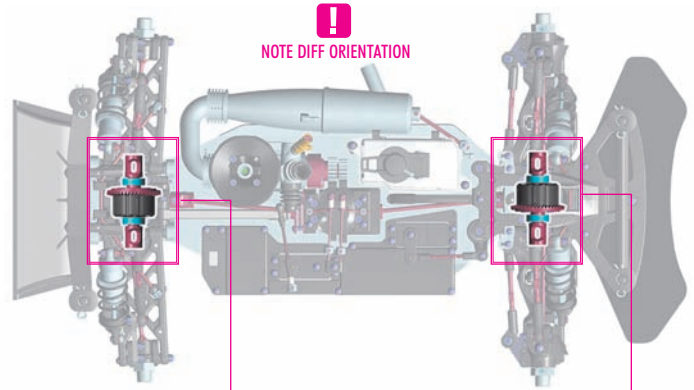

During assembly, there is no need to check gear mesh or diff play. In particular, do not check gear mesh and diff play when the differential is installed only in the gear box without the suspension holders and without being mounted to the chassis. All parts have specifically designed play, and only when the car is fully assembled will it have the proper amount of play where necessary. Only once you build the entire car, then you can check for free movement of all rotational parts and drivetrain as well as a free non-binding operation of suspension parts.

## 2. FRONT & REAR TRANSMISSION

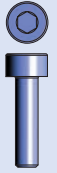

908312  
SCH M3x12

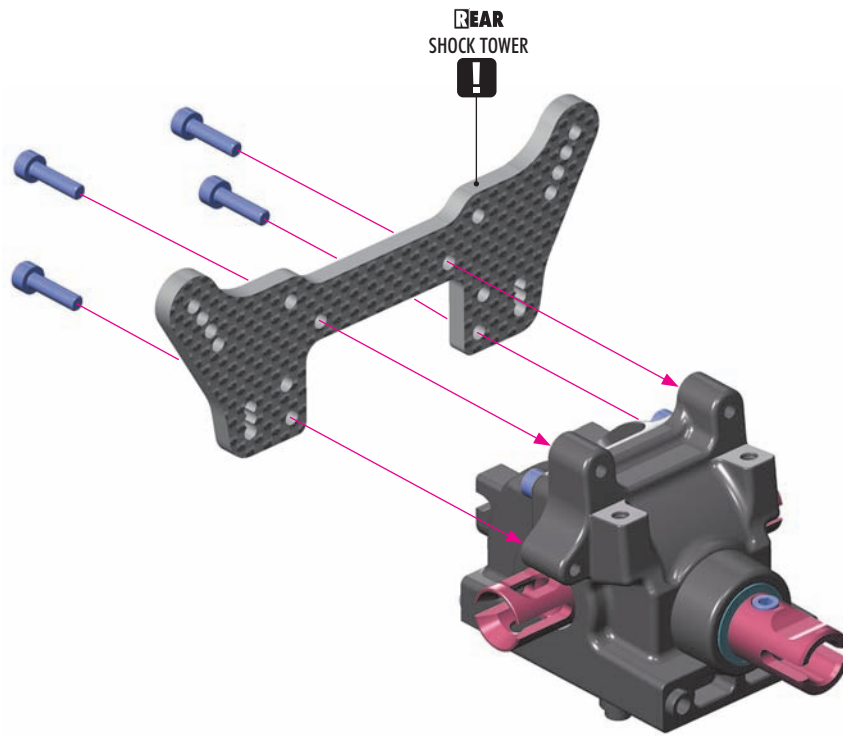

908312  
SCH M3x12

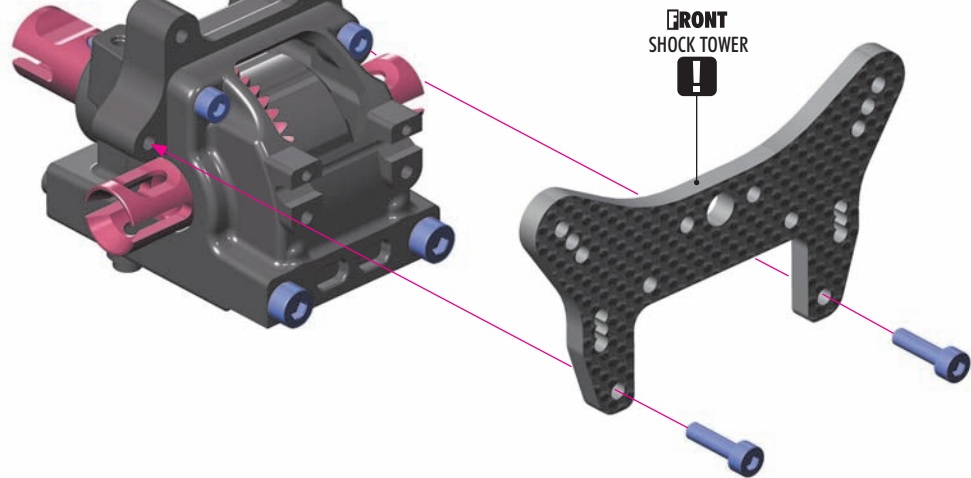

### 3. REAR SUSPENSION



#### REAR ANTI-ROLL BARS

#353418	ø1.8mm	OPTION
#353420	ø2.0mm	OPTION
#353422	ø2.2mm	OPTION
#353424	ø2.4mm	OPTION
#353425	ø2.5mm	OPTION
#353426	ø2.6mm	OPTION
#353428	ø2.8mm	INCLUDED
#353430	ø3.0mm	OPTION
#353432	ø3.2mm	OPTION



#### REAR SUSPENSION ARMS

#353115	MEDIUM	OPTION
#353116	HARD	INCLUDED
#353116-XH	X-HARD	OPTION
#353116-G	GRAPHITE	OPTION

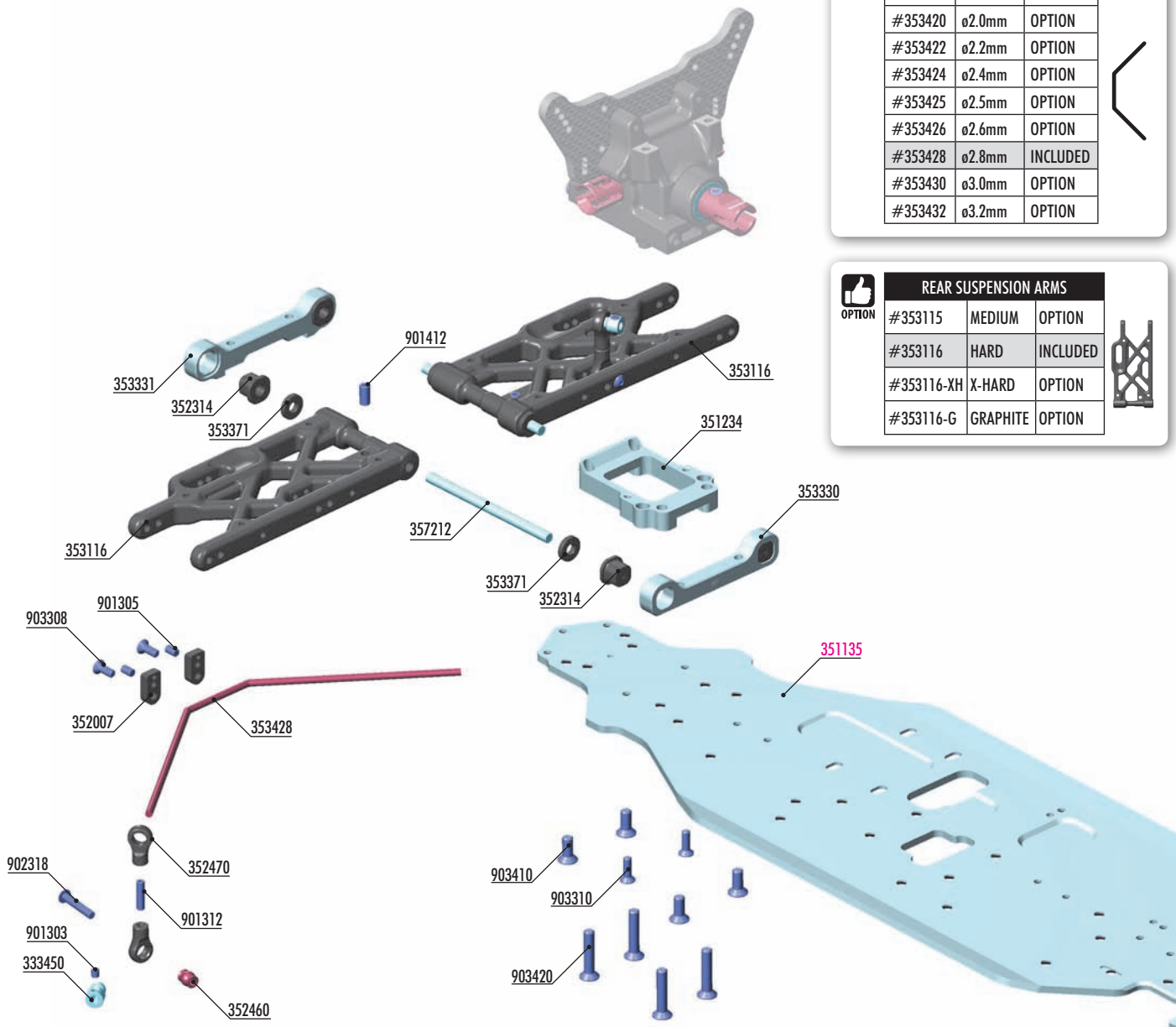

#333451  
ALU ANTI-ROLL BAR PIVOT BALL 5.8 MM  
- SWISS 7075 T6 - HARDCOATED (2)



**BAG**

**03**

- 333450 ANTI-ROLL BAR BALL JOINT 5.8 MM (2)
- 351234 ALU REAR DIFF BULKHEAD BLOCK PLATE
- 352007 DIFF BULKHEAD BLOCK WITH AIR COOLING SET FRONT/REAR
- 352314 COMPOSITE ECCENTRIC BUSHINGS - V2 (2)
- 352460 PIVOT BALL 5.8 (10)
- 352470 BALL JOINT 5.8 (8)
- 353116 COMPOSITE REAR LOWER SUSPENSION ARM - HARD
- 353330 ALU REAR LOWER SUSP. HOLDER - FRONT - SQUARE ADJ. ROLL-C.
- 353331 ALU REAR LOWER SUSP. HOLDER - REAR - SQUARE ADJ. ROLL-C.
- 353371 SET OF COMPOSITE LOWER ARM SHIMS
- 353428 REAR ANTI-ROLL BAR 2.8MM
- 357212 LOWER INNER PIVOT PIN F+R (2)

- 901303 HEX SCREW SB M3x3 (10)
- 901305 HEX SCREW SB M3x5 (10)
- 901312 HEX SCREW SB M3x12 (10)
- 901412 HEX SCREW SB M4x12 (10)
- 902318 HEX SCREW SH M3x18 (10)
- 903308 HEX SCREW SFH M3x8 (10))
- 903310 HEX SCREW SFH M3x10 (10))
- 903410 HEX SCREW SFH M4x10 (10))
- 903420 HEX SCREW SFH M4x20 (10))

351135 GTX'22 ALU CHASSIS - SWISS 7075 T6 (3MM)

### 3. REAR SUSPENSION



353371  
SHIM 4x10x2



901412  
SB M4x12

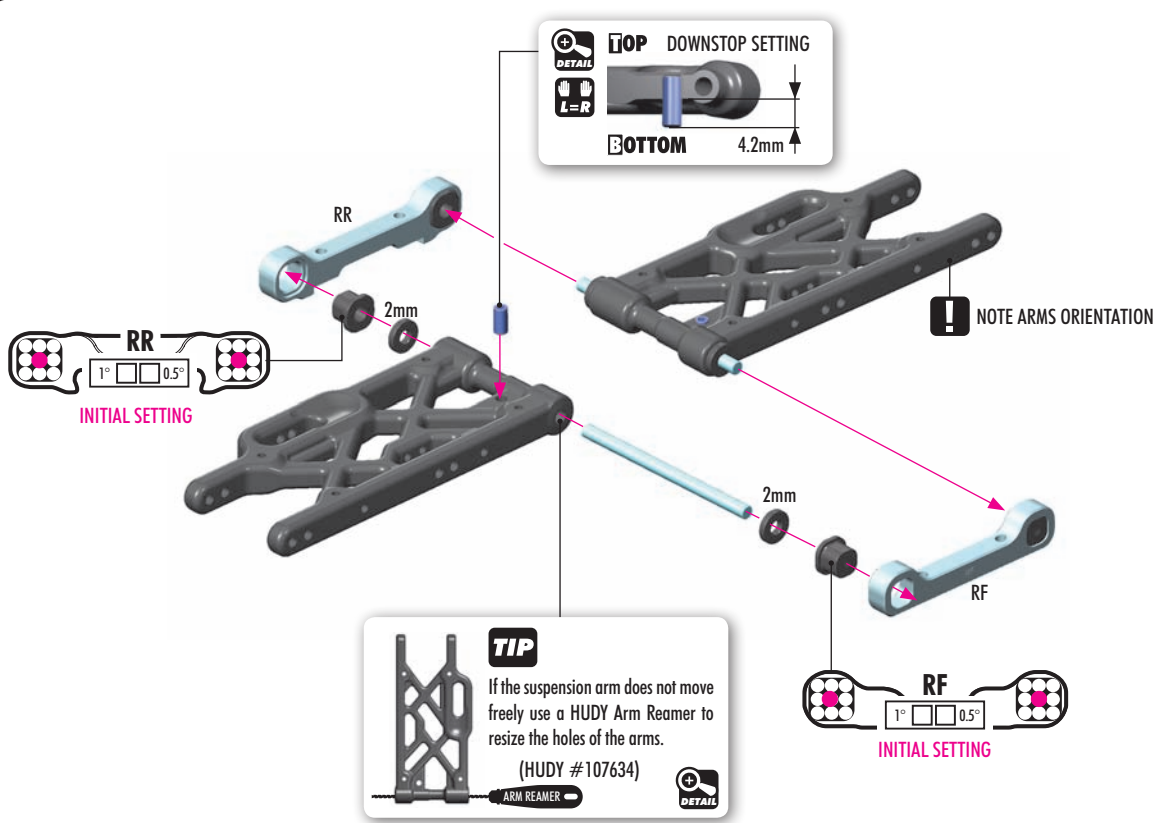

ANTI-SQUAT		
RR	RF	(°)
[Diagram]	[Diagram]	= 1°
[Diagram]	[Diagram]	= 2°
[Diagram]	[Diagram]	= 0°
[Diagram]	[Diagram]	= 2°
[Diagram]	[Diagram]	= 1°
[Diagram]	[Diagram]	= 3°
[Diagram]	[Diagram]	= 0°
[Diagram]	[Diagram]	= 1°
[Diagram]	[Diagram]	= -1°

The new XRAY rear alu lower suspension holders provide even greater range of adjustment for the rear suspension. Using different combinations of eccentric bushings, fine adjustment of rear anti-squat, rear toe-in, rear roll center, and rear track-width can be obtained. For more information about the influence of rear anti-squat, rear toe-in, rear roll center and rear track width on car handling, please refer to HUDY Off-Road Set-up Book (#209099).

ROLL CENTER		
RR	RF	(mm)
[Diagram]	[Diagram]	= 0mm
[Diagram]	[Diagram]	= 1mm
[Diagram]	[Diagram]	= -1mm

TRACK-WIDTH		
RR	RF	(mm)
[Diagram]	[Diagram]	= 308
[Diagram]	[Diagram]	= 306
[Diagram]	[Diagram]	= 310

The tables describe the amounts of rear anti-squat, rear toe-in, rear track-width change depending on the combinations of eccentric bushings used with 0 and 1mm, 1° off set. The 0.5mm, 0.5° represent the half change.

TOE-IN		
RR	RF	(°)
[Diagram]	[Diagram]	= 3°
[Diagram]	[Diagram]	= 4°
[Diagram]	[Diagram]	= 2°
[Diagram]	[Diagram]	= 2°
[Diagram]	[Diagram]	= 3°
[Diagram]	[Diagram]	= 1°
[Diagram]	[Diagram]	= 4°
[Diagram]	[Diagram]	= 5°
[Diagram]	[Diagram]	= 3°

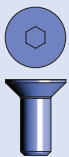

903410  
SFH M4x10

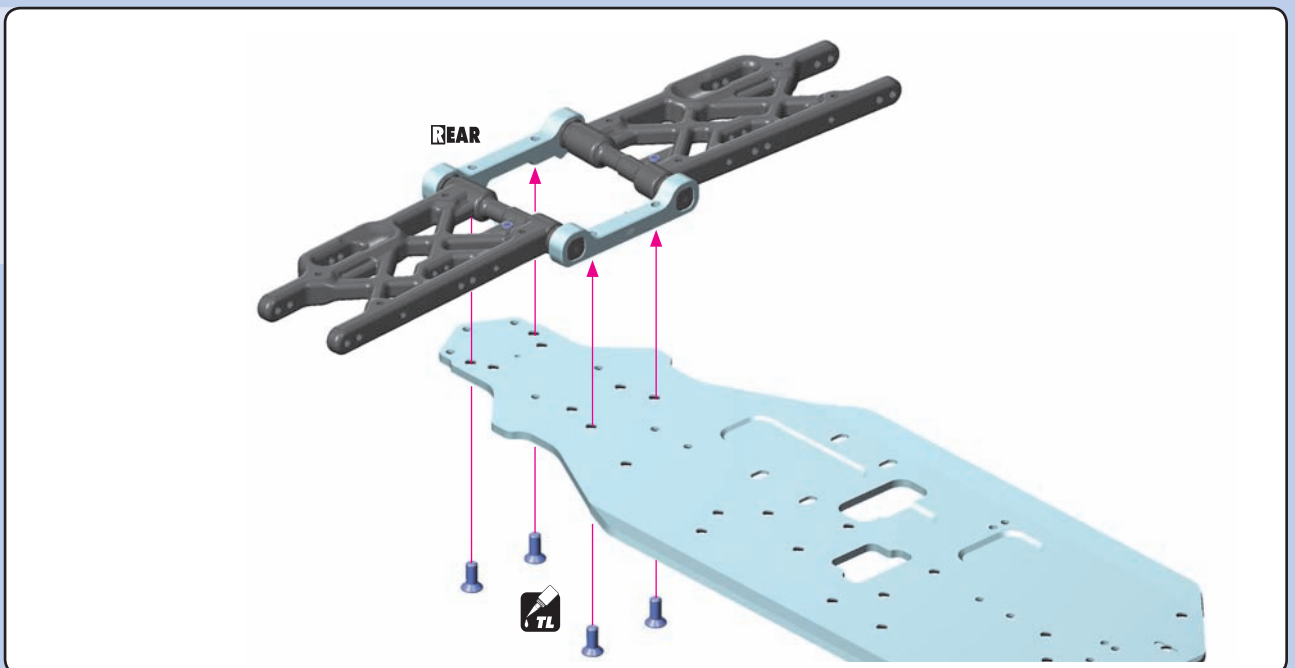

### 3. REAR SUSPENSION



903310  
SFH M3x10



903420  
SFH M4x20

**REAR**

NOTE ORIENTATION !

3x10mm

4x20mm

Check for free movement.

Push the arm from both sides to create play.



901312  
SB M3x12

2x L=R

TIP

Install the pivot balls with Professional Multi Tool (HUDY #183011).

1.5mm

6mm



901303  
SB M3x3



901305  
SB M3x5



902318  
SH M3x18

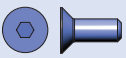

903308  
SFH M3x8

**REAR**

**RIGHT**

**LEFT**

3x3mm

3x3mm

3x18mm

3x5mm

3x8mm

0mm

Loosen the 3x5 setscrew if the anti-roll bar does not turn freely.

Step 1 check for free movement.

SET-UP BOOK  
ANTI-ROLL BAR  
INITIAL SETTING

# 4. REAR SUSPENSION



OFFSET WHEEL AXLES		
#355250	0mm	OPTION
#355251	+1mm	OPTION
#355252	+2mm	INCLUDED



XRAY BALL-BEARING				
#930816	8x16x5	GREASE	STEEL	OPTION
#940816	8x16x5	GREASE	RUBBER	OPTION
#931318	13x19x4	GREASE	STEEL	OPTION
#941318	13x19x4	GREASE	RUBBER	OPTION
#930817	8x16x5	OIL	STEEL	OPTION
#940817	8x16x5	OIL	RUBBER	INCLUDED
#931319	13x19x4	OIL	STEEL	OPTION
#941319	13x19x4	OIL	RUBBER	INCLUDED

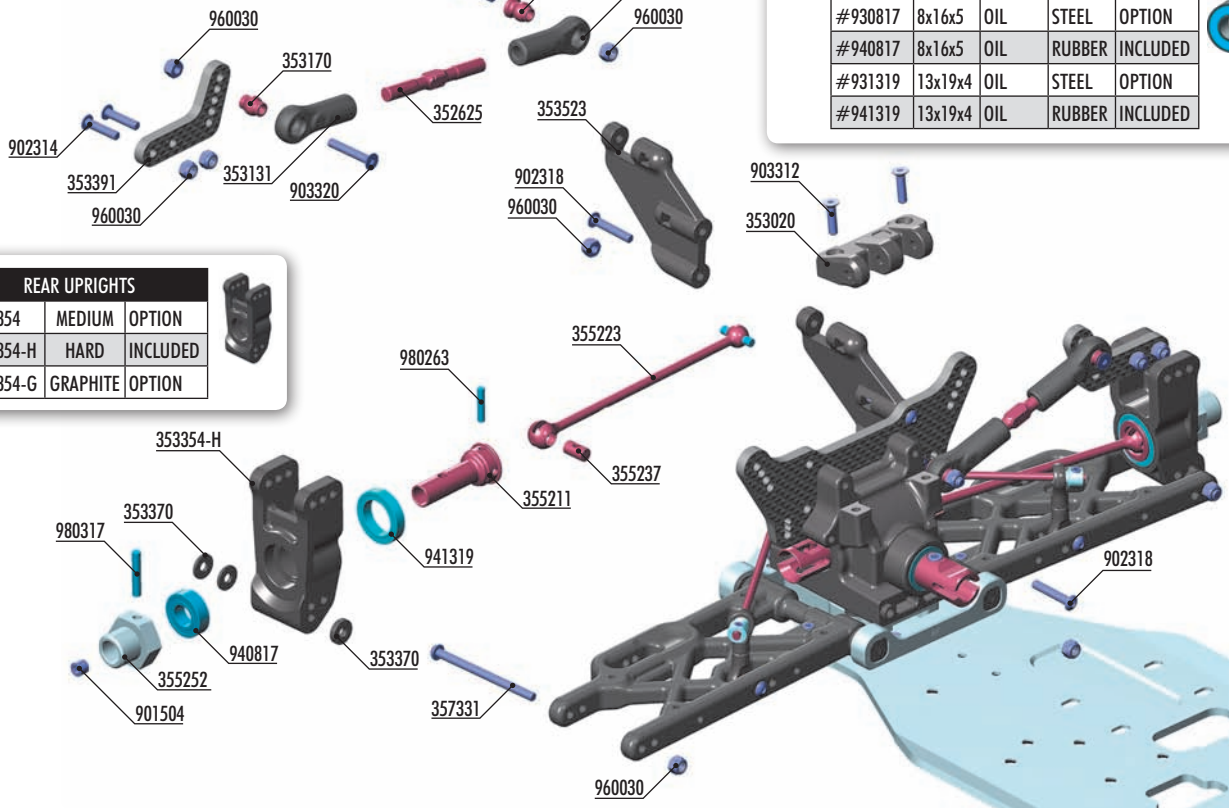

REAR UPRIGHTS		
#353354	MEDIUM	OPTION
#353354-H	HARD	INCLUDED
#353354-G	GRAPHITE	OPTION



**BAG**

**04**

- 352625 ADJ. TURNBUCKLE M5 L/R 46MM - HUDY SPRING STEEL™ (2)
- 353020 COMPOSITE REAR BRACE HOLDER
- 353131 REAR UPPER INNER CAMBER LINK BALL JOINT - V3 (2)
- 353160 MOUNTING BALL 6.8 (4)
- 353170 PIVOT BALL 6.8 (4)
- 353354-H COMPOSITE REAR UPRIGHT LB - HARD
- 353370 SET OF COMPOSITE REAR HUB CARRIER SHIMS
- 353391 GRAPHITE REAR ROLL CENTER UPRIGHT PLATE 4MM (2)
- 353523 GT COMPOSITE REAR HOLDER POST (2)
- 355211 CVD DRIVE AXLE - HUDY SPRING STEEL™
- 355223 CVD UNIVERSAL DRIVE SHAFT 93MM - HUDY SPRING STEEL™
- 355237 CVD DRIVE SHAFT COUPLING - HUDY SPRING STEEL™
- 355252 ALU WHEEL AXLE OFFSET +2MM - BLACK COATED (2)
- 357331 REAR LOWER OUTER PIVOT PIN SCREW 3MM (2)
- 901504 HEX SCREW SB M5x4 (10)
- 902314 HEX SCREW SH M3x14 (10)
- 902318 HEX SCREW SH M3x18 (10)
- 903312 HEX SCREW SFH M3x12 (10)
- 903320 HEX SCREW SFH M3x20 (10)
- 940817 BALL-BEARING 8x16x5 RUBBER SEALED - OIL (2)
- 941319 BALL-BEARING 13x19x4 RUBBER SEALED - OIL (2)
- 960030 NUT M3 (10)
- 980263 PIN 2.5x13 (10)
- 980317 PIN 3x17 (10)



941319  
BB 13x19x4

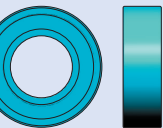

940817  
BB 8x16x5

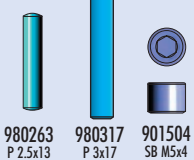

980263 P 2.5x13  
980317 P 3x17  
901504 SB M5x4

**2x** **L=R**

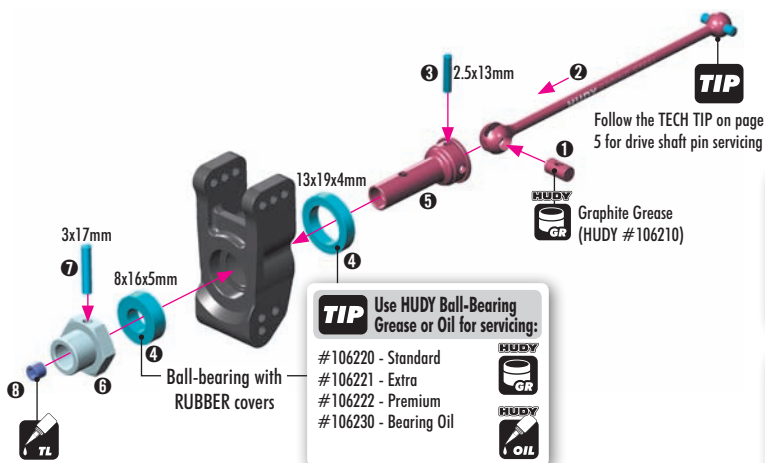

**TIP**

To tighten the setscrew you can also use the HUDY 17mm Wheel Nut Tool #107570.

**L=R**



OFFSET WHEEL AXLES		
#355250	0mm	OPTION
#355251	+1mm	OPTION
#355252	+2mm	INCLUDED



REAR UPRIGHTS		
#353354	MEDIUM	OPTION
#353354-H	HARD	INCLUDED
#353354-G	GRAPHITE	OPTION



# 4. REAR SUSPENSION



353370  
SHIM 3x9x1



353370  
SHIM 3x9x2



960030  
N M3

2x L=R

**TIP** Ensure that the rear upright moves freely. If it does not move freely, use sandpaper to thin both wheelbase adjustment shims.

Shims for wheelbase adjustment

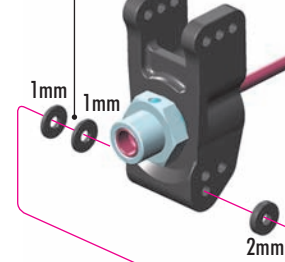

REAR

LEFT

RIGHT

Do not overtighten the self-locking nut. Overtightening may result in suspension binding.



**TIP** L=R

If the suspension arm does not move freely use a HUDY Arm Reamer to resize the holes of the arms. (HUDY #107633)

ARM REAMER

**DETAIL**

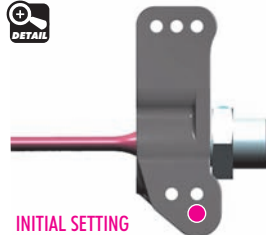

INITIAL SETTING

**DETAIL**

Check for free movement.

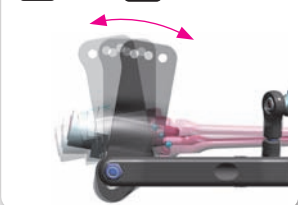

2x L=R

**TIP**

Install the pivot balls with Professional Multi Tool (HUDY #183011).

**NOTE ORIENTATION**



**NOTE ORIENTATION**



OIL  
LEFT THREAD

OIL  
RIGHT THREAD

Use tools to tighten as shown.

**DETAIL**



Special Tool for all turnbuckles & nuts (HUDY #181090) or Turnbuckle Wrench 5mm (HUDY #181050).

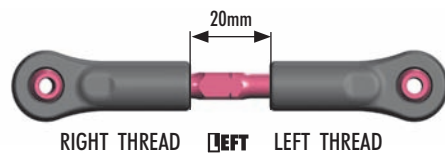
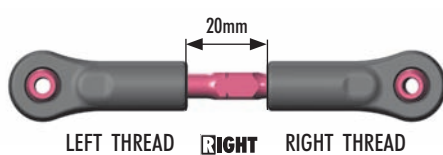

**SET-UP BOOK**

CAMBER

# 4. REAR SUSPENSION

902314  
SH M3x14

902318  
SH M3x18

903320  
SFH M3x20

960030  
N M3

**2x**

**INITIAL SETTING**

Install the nut with Multi Tool (HUDY #181090).  
**TIP**

3x18mm

3x14mm

3x20mm

**INITIAL SETTING**

**INITIAL SETTING**

903312  
SFH M3x12

**REAR**

**RIGHT**

**LEFT**

**2x**

902318  
SH M3x18

960030  
N M3

**REAR**

**RIGHT**

**LEFT**



# 5. FRONT SUSPENSION



#333451  
ALU ANTI-ROLL BAR PIVOT BALL 5.8 MM - SWISS 7075 T6 - HARDCOATED (2)

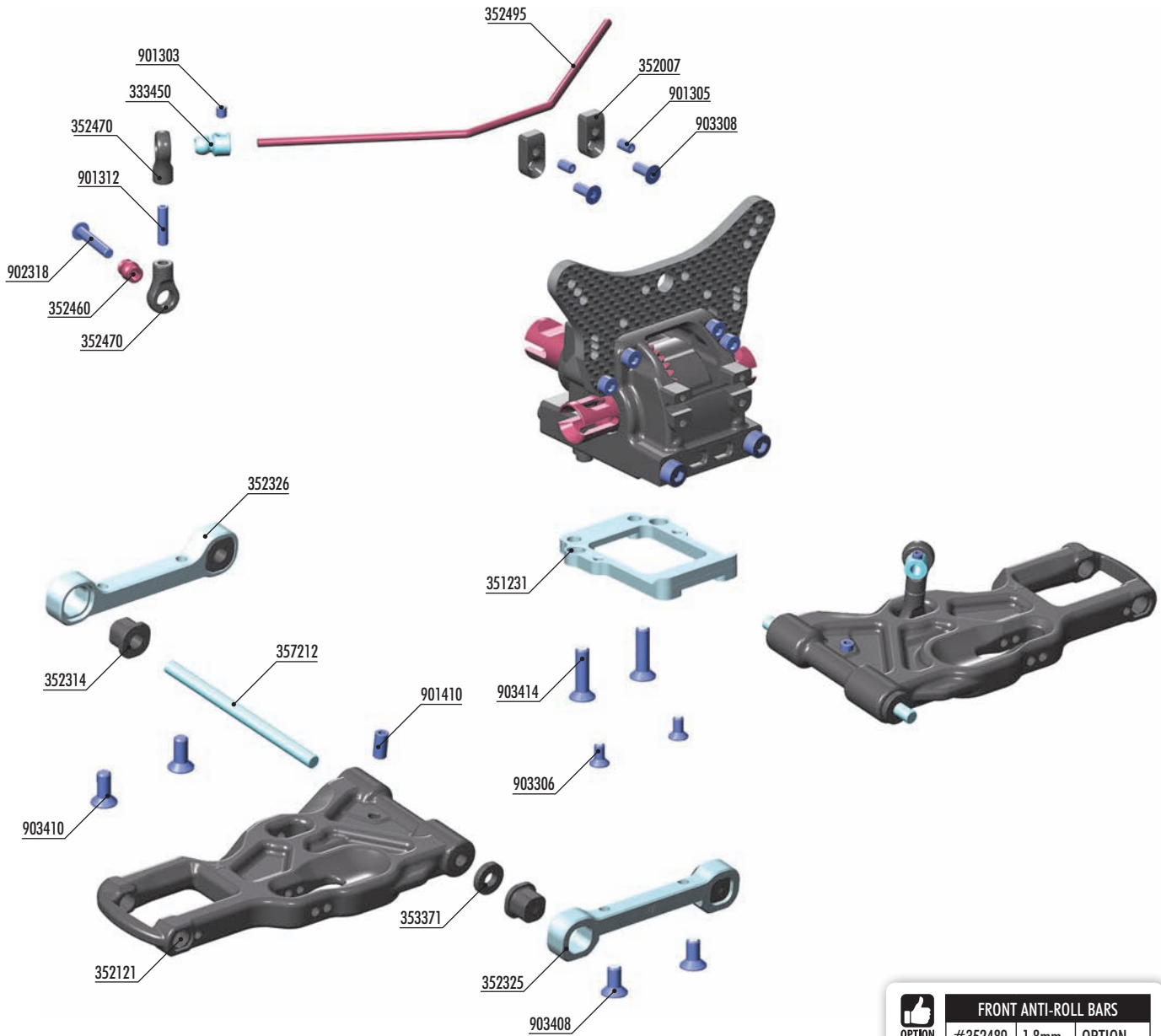

FRONT LOWER SUSP. ARMS		
#352121-S	SOFT	OPTION
#352121	MEDIUM	INCLUDED
#352121-H	HARD	OPTION
#352121-G	GRAPHITE	OPTION



### FRONT ANTI-ROLL BARS

#352489	1.8mm	OPTION
#352490	2.0mm	OPTION
#352492	2.2mm	OPTION
#352493	2.3mm	OPTION
#352494	2.4mm	OPTION
#352495	2.5mm	INCLUDED
#352496	2.6mm	OPTION
#352498	2.8mm	OPTION

**BAG**

**05**

333450 ANTI-ROLL BAR BALL JOINT 5.8 MM (2)  
 351231 ALU FRONT DIFF BULKHEAD BLOCK PLATE  
 352007 DIFF BULKHEAD BLOCK WITH AIR COOLING SET FRONT/REAR  
 352121 C-HUB COMPOSITE FRONT LOWER SUSPENSION ARM - MEDIUM  
 352314 COMPOSITE SQUARE ADJ. ROLL CENTER BUSHINGS - V2 (2)  
 352325 ALU FRONT LOWER SUSP. HOLDER - FRONT - SQUARE ADJ. ROLL-C.  
 352326 ALU FRONT LOWER SUSP. HOLDER - REAR - SQUARE ADJ. ROLL-C.  
 352460 PIVOT BALL 5.8 (10)  
 352470 BALL JOINT 5.8 (8)  
 352495 FRONT ANTI-ROLL BAR 2.5MM  
 353371 SET OF COMPOSITE LOWER ARM SHIMS

357212 LOWER INNER PIVOT PIN F+R (2)  
 901303 HEX SCREW SB M3x3 (10)  
 901305 HEX SCREW SB M3x5 (10)  
 901312 HEX SCREW SB M3x12 (10)  
 901410 HEX SCREW SB M4x10 (10)  
 902318 HEX SCREW SH M3x18 (10)  
 903306 HEX SCREW SFH M3x6 (10))  
 903308 HEX SCREW SFH M3x8 (10))  
 903408 HEX SCREW SFH M4x8 (10))  
 903410 HEX SCREW SFH M4x10 (10))  
 903414 HEX SCREW SFH M4x14 (10))

# 5. FRONT SUSPENSION



353371  
SHIM 4x10x2



901410  
SB M4x10

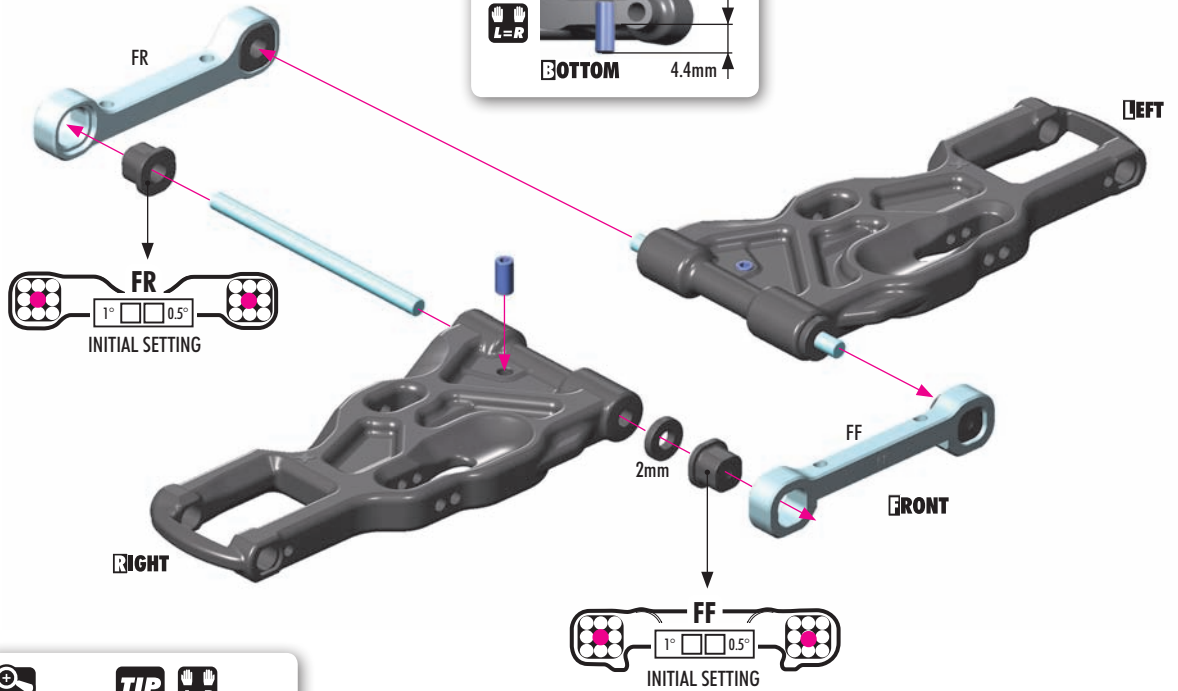
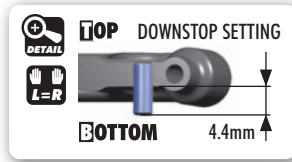
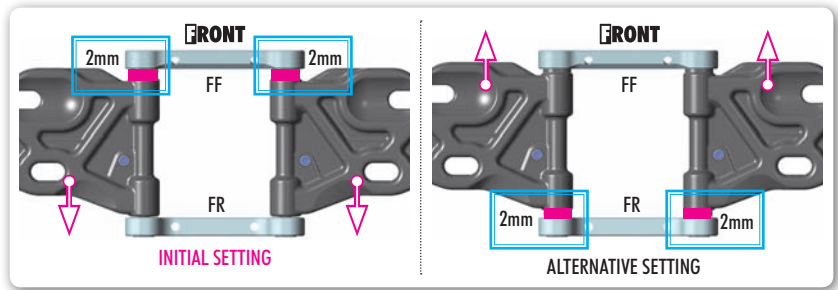

**TIP** **L=R**

If the suspension arms do not move freely, use a HUDY Arm Reamer to resize the holes.

(HUDY #107634)

ARM REAMER

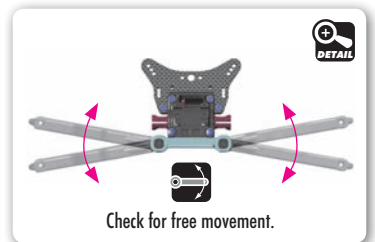
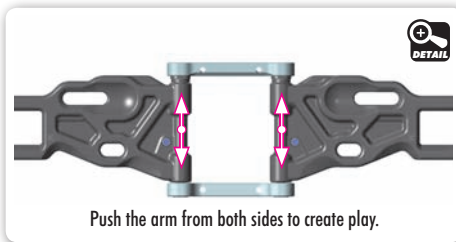
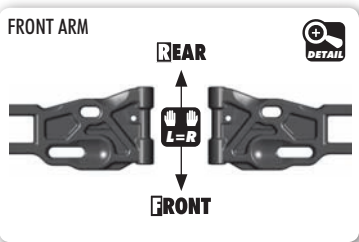

Eccentric bushings have two different offsets from the center.

- Middle position = 0.5 mm or 0.5° from center
- Outer position = 1mm or 1° from center

The XRAY alu front lower suspension holders provide even greater range of adjustment for the front suspension. Using different combinations of eccentric bushings, fine adjustment of front kick-up, roll center, and front track-width can be obtained. For more information about the influence of kick-up, front track-width, and roll centers on car handling, please refer to HUDY Off-Road Set-up Book (#209099).

TRACK-WIDTH		
FF	FR	(mm)
		=308
		=306
		=310

ROLL CENTER		
FF	FR	(mm)
		=1
		=0
		=-1

The tables below describe the amounts of kick-up, front track-width change depending on the combinations of eccentric bushings used with 0 and 1mm, 1° offset. The 0.5mm, 0.5° represents the half change.

**SET-UP BOOK**  
KICK UP  
ROLL CENTER DOWNSTOP  
WHEELBASE  
TRACK WIDTH

## 5. FRONT SUSPENSION



903408  
SFH M4x8



903410  
SFH M4x10

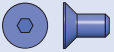
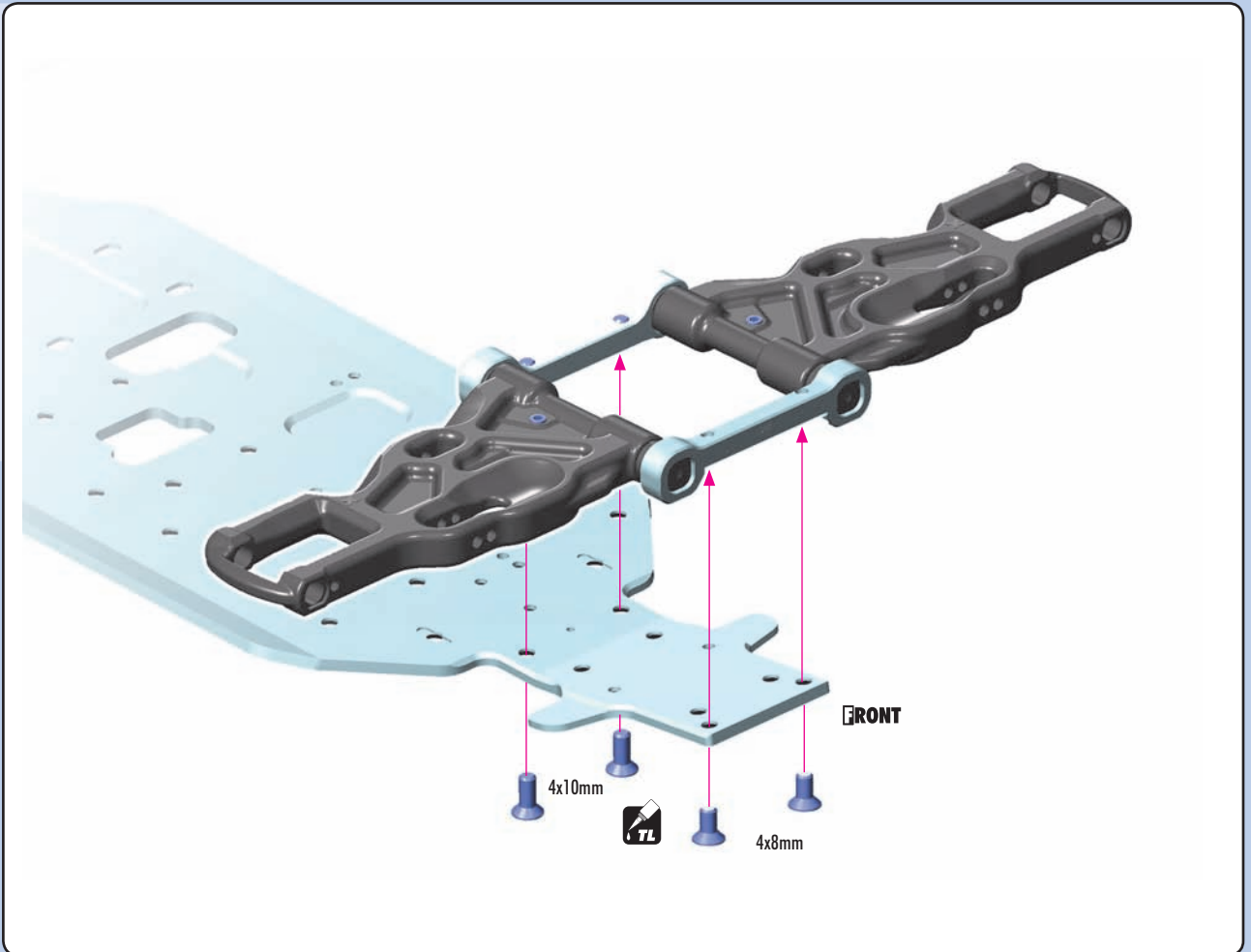

903306  
SFH M3x6



903414  
SFH M4x14

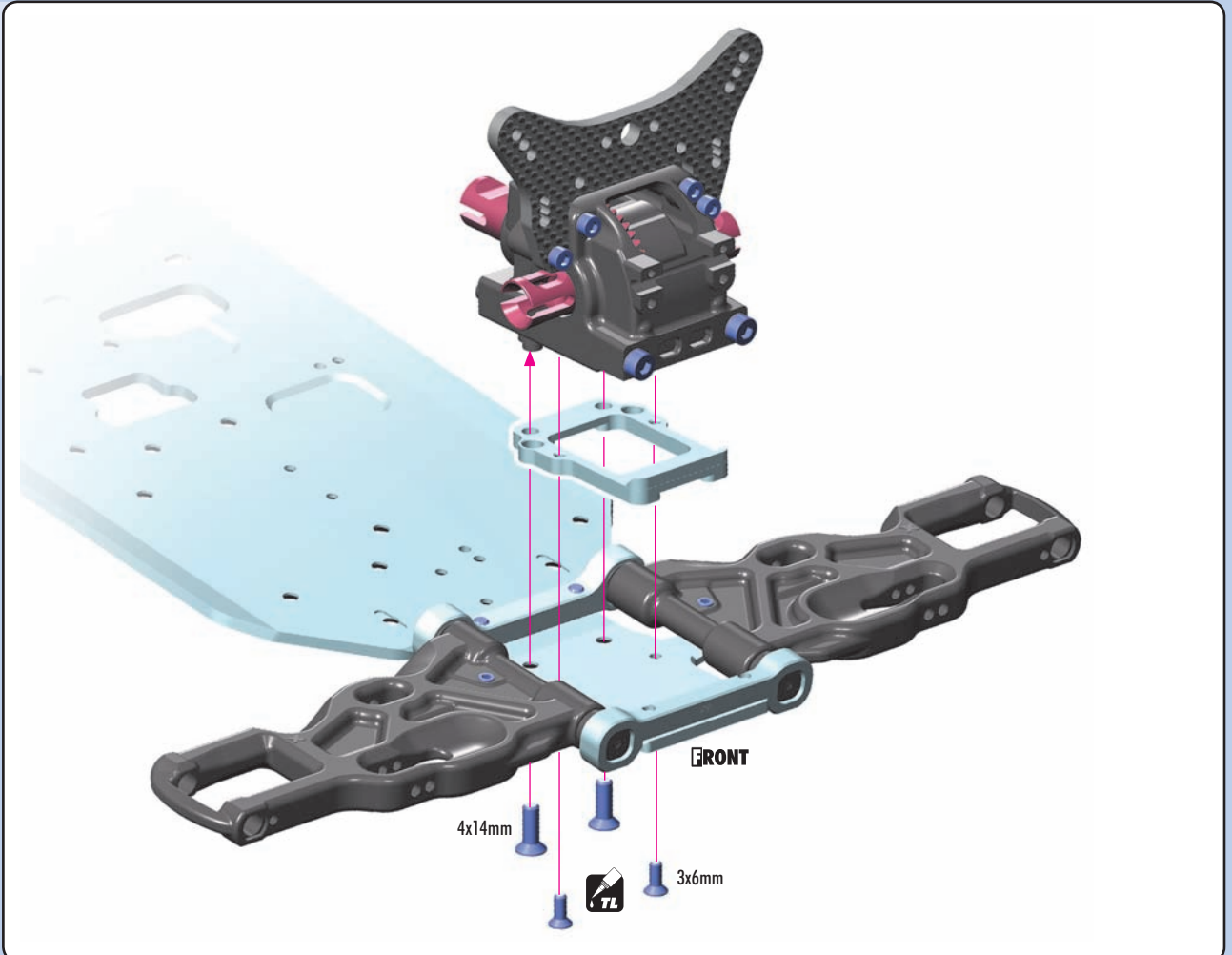

# 5. FRONT SUSPENSION



901312  
SB M3x12

2x L=R

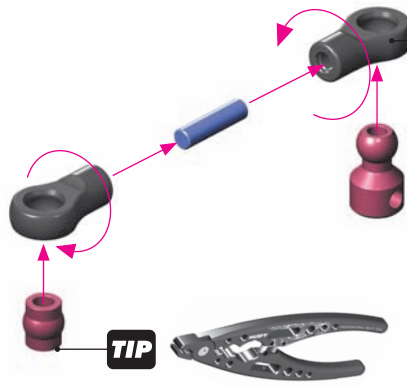

**TIP**

Install the pivot balls with Professional Multi Tool (HUDY #183011).

**DETAIL**

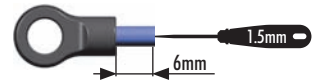

**DETAIL**

L=R



901303  
SB M3x3



901305  
SB M3x5



902318  
SH M3x18



903308  
SFH M3x8

**REAR**

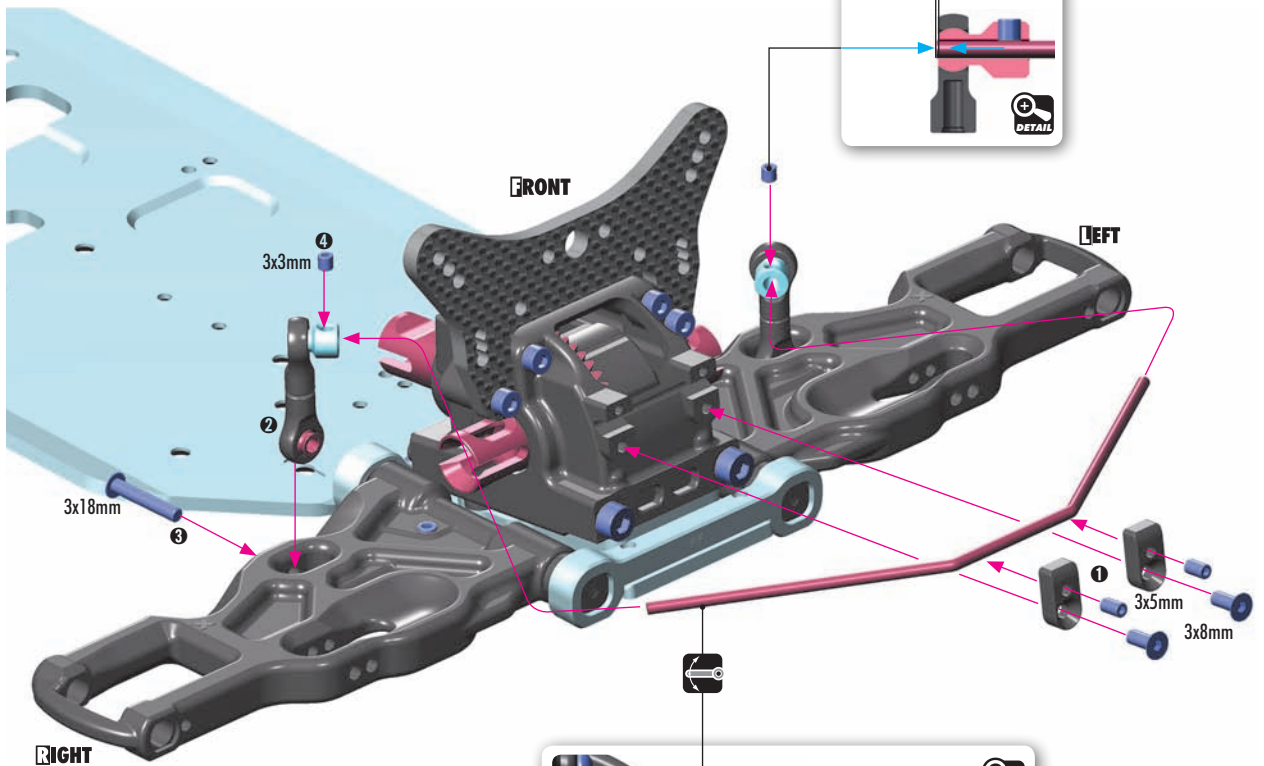

**STEP 4 DETAIL**

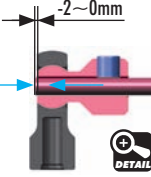

**DETAIL**

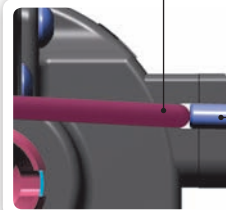

**Step 1**  
Loosen the 3x5 setscrew if the anti-roll bar does not turn freely.



**OPTION**

**FRONT ANTI-ROLL BARS**

#352489	1.8mm	OPTION
#352490	2.0mm	OPTION
#352492	2.2mm	OPTION
#352493	2.3mm	OPTION
#352494	2.4mm	OPTION
#352495	2.5mm	INCLUDED
#352496	2.6mm	OPTION
#352498	2.8mm	OPTION

**DETAIL**

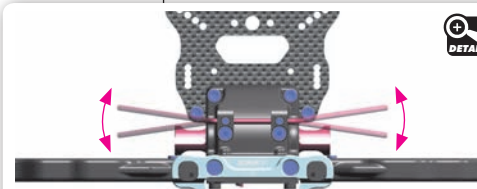

**Step 1** check for free movement.

**SET-UP BOOK**  
ANTI-ROLL BAR

# 6. FRONT SUSPENSION

**OFFSET WHEEL AXLES**

OPTION	#355250	0mm	OPTION
	#355251	+1mm	OPTION
	#355252	+2mm	INCLUDED

**#352180 BALL MOUNT (2)**

OPTION

**STEERING BLOCK**

OPTION	#352245	COMP.	INCLUDED
	#352254	ALU	OPTION

**ECCENTRIC BUSHINGS**

OPTION	#352170	0° - STEEL	OPTION
	#352174	1° - STEEL	OPTION
	#352175	2° - STEEL	OPTION
	#352179	0° - COMP.	INCLUDED

**CASTER BLOCK - RIGHT**

OPTION	#352273	18° RIGHT	ALU	OPTION
	#352275	2° RIGHT	ALU	OPTION
	#352277	16° RIGHT	COMP.	OPTION
	#352278	6° RIGHT	ALU	OPTION
	#352279	6° RIGHT	COMP.	INCLUDED

**CASTER BLOCK - LEFT**

OPTION	#352283	18° LEFT	ALU	OPTION
	#352285	2° LEFT	ALU	OPTION
	#352287	16° LEFT	COMP.	OPTION
	#352288	6° LEFT	ALU	OPTION
	#352289	6° LEFT	COMP.	INCLUDED

**BAG**

**06**

- |        |   |        |  |
|--------|---|--------|--|
| 303123 | ALU SHIM 3x6x2.0MM (10)                               | 355252 | ALU WHEEL AXLE OFFSET "+2MM" - HARD COATED (2) |
| 352179 | COMPOSITE BUSHING & BALL MOUNT SET (2+2)              | 357230 | FRONT LOWER OUTER PIVOT PIN (2)                |
| 352245 | C-HUB STEERING BLOCK LB WITH ALU INSERTS              | 901504 | HEX SCREW SB M5x4 (10)                         |
| 352279 | COMPOSITE C-HUB 6° RIGHT                              | 902305 | HEX SCREW SH M3x5 (10)                         |
| 352289 | COMPOSITE C-HUB 6° LEFT                               | 902308 | HEX SCREW SH M3x8 (10)                         |
| 352293 | STEEL C-HUB BUSHING (2)                               | 902318 | HEX SCREW SH M3x18 (10)                        |
| 352369 | GRAPHITE STEERING PLATE (2)                           | 902325 | HEX SCREW SH M3x25 (10)                        |
| 352625 | ADJ. TURNBUCKLE M5 L/R 46 MM - HUDY SPRING STEEL™ (2) | 902412 | HEX SCREW SH M4x12 (10)                        |
| 353131 | REAR UPPER INNER CAMBER LINK BALL JOINT - V3 (2)      | 940817 | BALL-BEARING 8x16x5 RUBBER SEALED - OIL (2)    |
| 353160 | MOUNTING BALL 6.8 (4)                                 | 941319 | BALL-BEARING 13x19x4 RUBBER SEALED - OIL (2)   |
| 353170 | PIVOT BALL 6.8 (4)                                    | 960030 | NUT M3 (10)                                    |
| 355211 | CVD DRIVE AXLE - HUDY SPRING STEEL™                   | 980263 | PIN 2.5x13 (10)                                |
| 355221 | CVD UNIVERSAL DRIVE SHAFT 94MM - HUDY SPRING STEEL™   | 980317 | PIN 3x17 (10)                                  |
| 355237 | CVD DRIVE SHAFT COUPLING - HUDY SPRING STEEL™         |        |  |

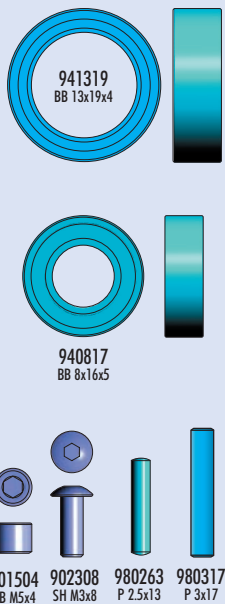

**OFFSET WHEEL AXLES**

OPTION	#355250	0mm	OPTION
	#355251	+1mm	OPTION
	#355252	+2mm	INCLUDED

**TIP** To tighten the setscrew you can also use the HUDY 17mm Wheel Nut Tool #107570.

**NOTE ORIENTATION**

Follow the TECH TIP on page 5 for drive shaft pin servicing. **TIP**

Graphite Grease (HUDY #106210)

**TIP** Use HUDY Ball-Bearing Grease or Oil for servicing:

- #106220 - Standard
- #106221 - Extra
- #106222 - Premium
- #106230 - Bearing Oil

# 6. FRONT SUSPENSION



902412  
SH M4x12

2x  
L=R

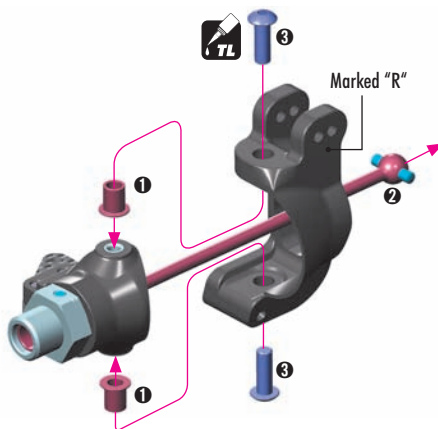

2x  
L=R

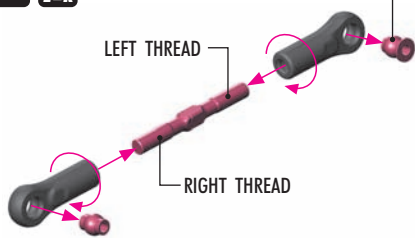

**TIP** Install the pivot balls with Professional Multi Tool (HUDY #183011).

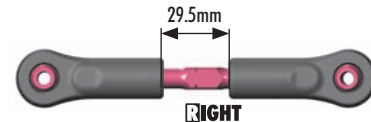
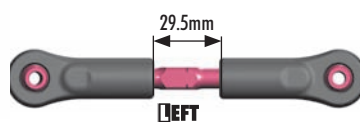

303123  
SHIM 3x6x2



902305  
SH M3x5

2x  
L=R

**OPTION** #352180 BALL MOUNT (2)



**TIP** Press pivot ball into arm until it snaps into place.

STEP 1 DETAIL

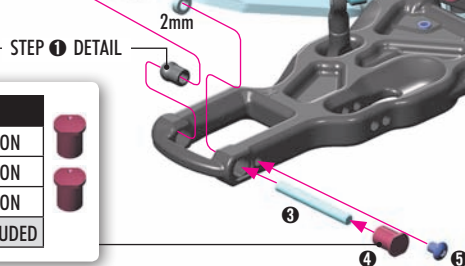

FRONT



**OPTION**

ECCENTRIC BUSHINGS			
#352170	0° - STEEL		OPTION
#352174	1° - STEEL		OPTION
#352175	2° - STEEL		OPTION
#352179	0° - COMP.		INCLUDED



960030  
N M3

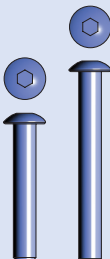

902318 902325  
SH M3x18 SH M3x25

2x  
L=R

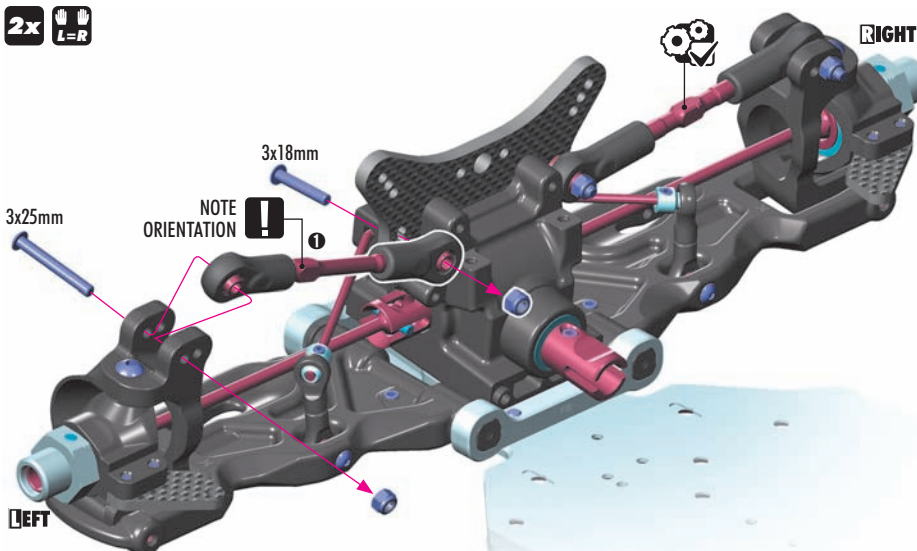

RIGHT

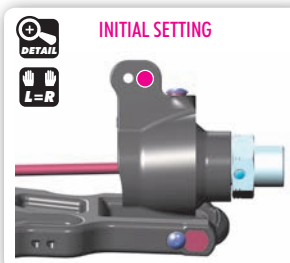
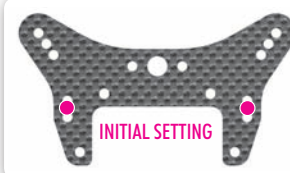

**SET-UP BOOK**  
ROLL CENTER

# 7. STEERING

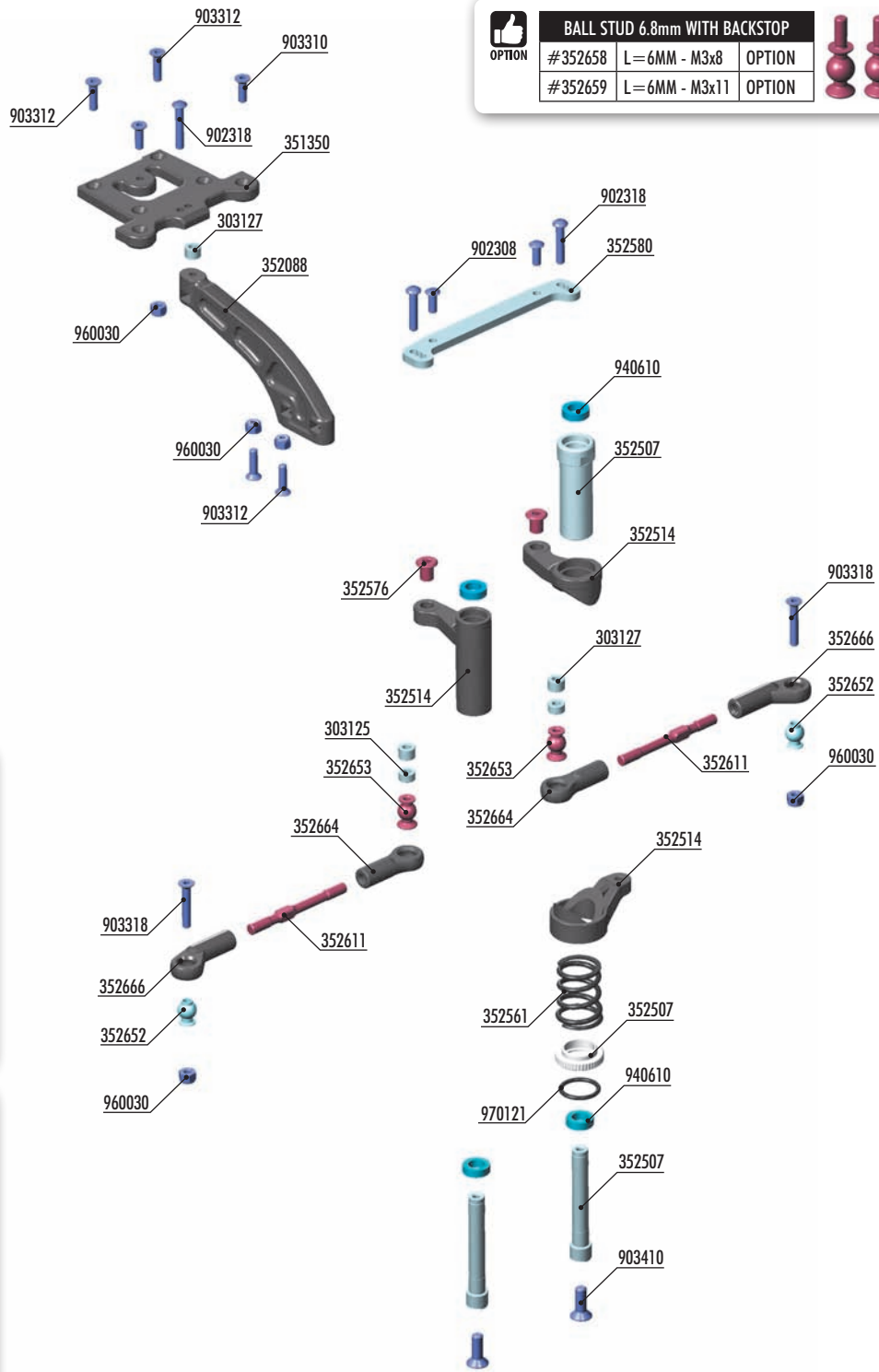

BALL STUD 6.8mm WITH BACKSTOP		
#352658	L=6MM - M3x8	OPTION
#352659	L=6MM - M3x11	OPTION

**#352084**  
OPTION COMPOSITE FRONT BRACE



**#351351**  
OPTION GRAPHITE UPPER PLATE

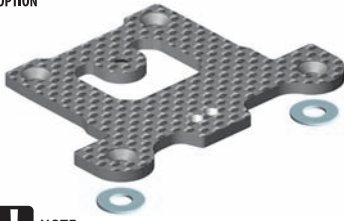

**NOTE**  
Must be used also 2pcs of #357256 shim 6x13x1mm.

**BAG**

**07**

- |        |  |        |   |
|--------|--|--------|---|
| 303125 | ALU SHIM 3x6x3.0MM (10)                                  | 903310 | HEX SCREW SFH M3x10 (10)                    |
| 303127 | ALU SHIM 3x6x4.0MM (10)                                  | 903312 | HEX SCREW SFH M3x12 (10)                    |
| 351350 | COMPOSITE UPPER PLATE WITH TWO BRACE POSITIONS           | 903318 | HEX SCREW SFH M3x18 (10)                    |
| 352088 | COMPOSITE FRONT BRACE                                    | 903410 | HEX SCREW SFH M4x10 (10)                    |
| 352507 | GT SERVO SAVER WITH CHASSIS LOCK & HARD SPRING - G - SET | 940610 | BALL-BEARING 6x10x3 RUBBER SEALED - OIL (2) |
| 352514 | COMPOSITE SERVO SAVER - GRAPHITE                         | 960030 | NUT M3 (10)                                 |
| 352561 | SERVO SAVER SPRING PROGRESSIVE                           | 970121 | O-RING 12.1 x 1.6 (10)                      |
| 352576 | STEERING PLATE BUSHING (2)                               |        |   |
| 352580 | ALU STEERING PLATE - SWISS 7075 T6                       |        |   |
| 352611 | ADJ. TURNBUCKLE M4 L/R 53MM - HUDY SPRING STEEL™ (2)     |        |   |
| 352652 | BALL STUD 6.8MM (4)                                      |        |   |
| 352653 | BALL STUD 6.8MM WITH BACKSTOP - M3 (2)                   |        |   |
| 352664 | COMPOSITE STEERING BALL JOINT 6.8MM - V3 (2)             |        |   |
| 352666 | COMPOSITE RELIEF STEERING BALL JOINT 6.8MM (2)           |        |   |
| 902308 | HEX SCREW SH M3x8 (10)                                   |        |   |
| 902318 | HEX SCREW SH M3x18 (10)                                  |        |   |

# 7. STEERING



970121  
O 12.1x1.6

**SET-UP BOOK**  
SERVO SAVER

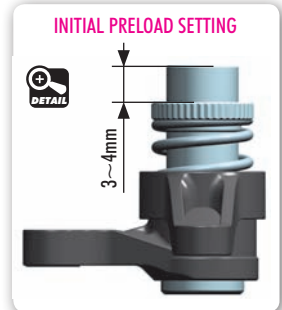
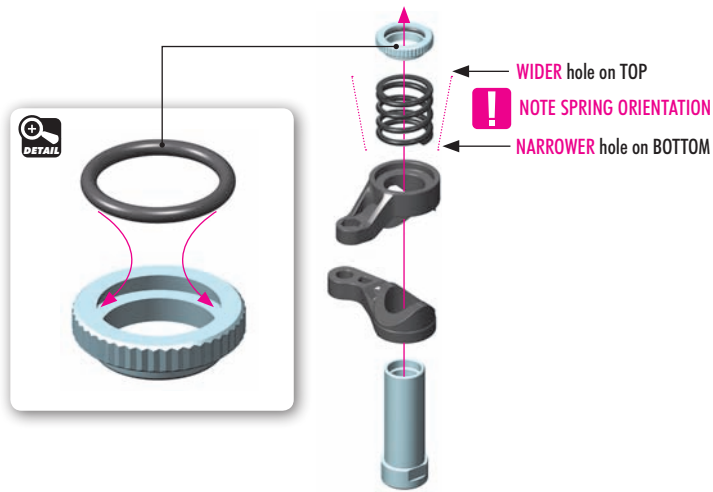

902308  
SH M3x8

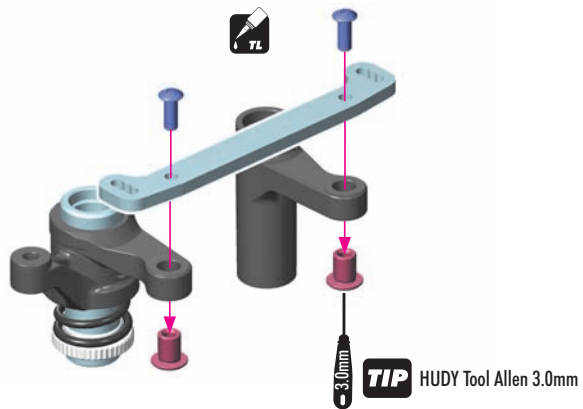

903410  
SFH M4x10



940610  
BB 6x10x3

For servicing use  
Bearing Oil (HUDY #106230).

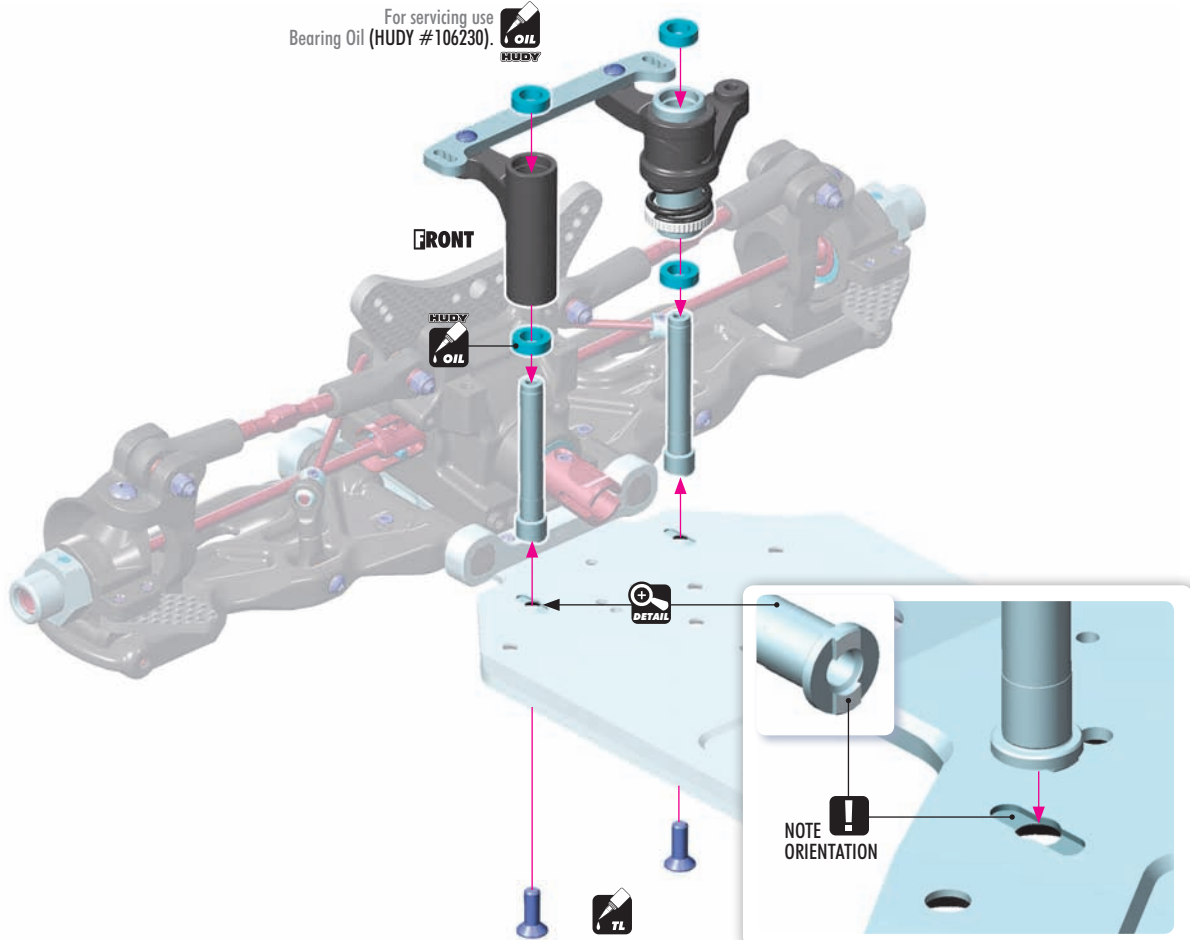



# 7. STEERING

**303127**  
SHIM 3x6x4

**902318**  
SH M3x18

**903310**  
SFH M3x10

**903312**  
SFH M3x12

**960030**  
N M3

**FRONT**

3x12mm

3x12mm

3x18mm

3x10mm

4mm

**USE ONLY RIGHT HOLE**

3x12mm

**DETAIL** Check for free movement.

After the top deck assembly check for free movement of steering system.

**2x** **L=R**

**NOTE ORIENTATION** **!**

LEFT THREAD

RIGHT THREAD

**NOTE ORIENTATION** **!**

**NOTE ORIENTATION** **!**

**NOTE ORIENTATION** **!**

RIGHT THREAD ← 31mm → LEFT THREAD → 31mm → RIGHT THREAD

**LEFT** **RIGHT**

**TIP** Use tools to tighten as shown.

Special Tool (HUDY #181090)

Turnbuckle Wrench 4mm (HUDY #181040)

Install the pivot balls with Professional Multi Tool (HUDY #183011).

**303125**  
SHIM 3x6x3

**303127**  
SHIM 3x6x4

**902318** **903318**  
SH M3x18 SFH M3x18

**960030**  
N M3

4mm

3mm

**INITIAL POSITION**

Check for free movement.

Check for free movement.

# 8. CENTER DIFF & BRAKE

**#354010-G**  
COMPOSITE CENTER DIFFERENTIAL MOUNTING PLATE SET - GRAPHITE



**OPTION**  
**COMPOSITE 2-SPEED GEARS**

#345545	45T	2ND	OPTION
#345546	46T	2ND	INCLUDED
#345547	47T	2ND	OPTION
#345548	48T	1ST	OPTION
#345549	49T	1ST	INCLUDED
#345550	50T	1ST	OPTION

**OPTION**  
**GRAPHITE 2-SPEED GEARS**

#345645	45T	2ND	OPTION
#345646	46T	2ND	OPTION
#345647	47T	2ND	OPTION
#345648	48T	1ST	OPTION
#345649	49T	1ST	OPTION
#345650	50T	1ST	OPTION

**OPTION**  
**#354113**  
SUPER-LIGHTWEIGHT VENTILATED BRAKE DISK - PRECISION-GROUND (2)

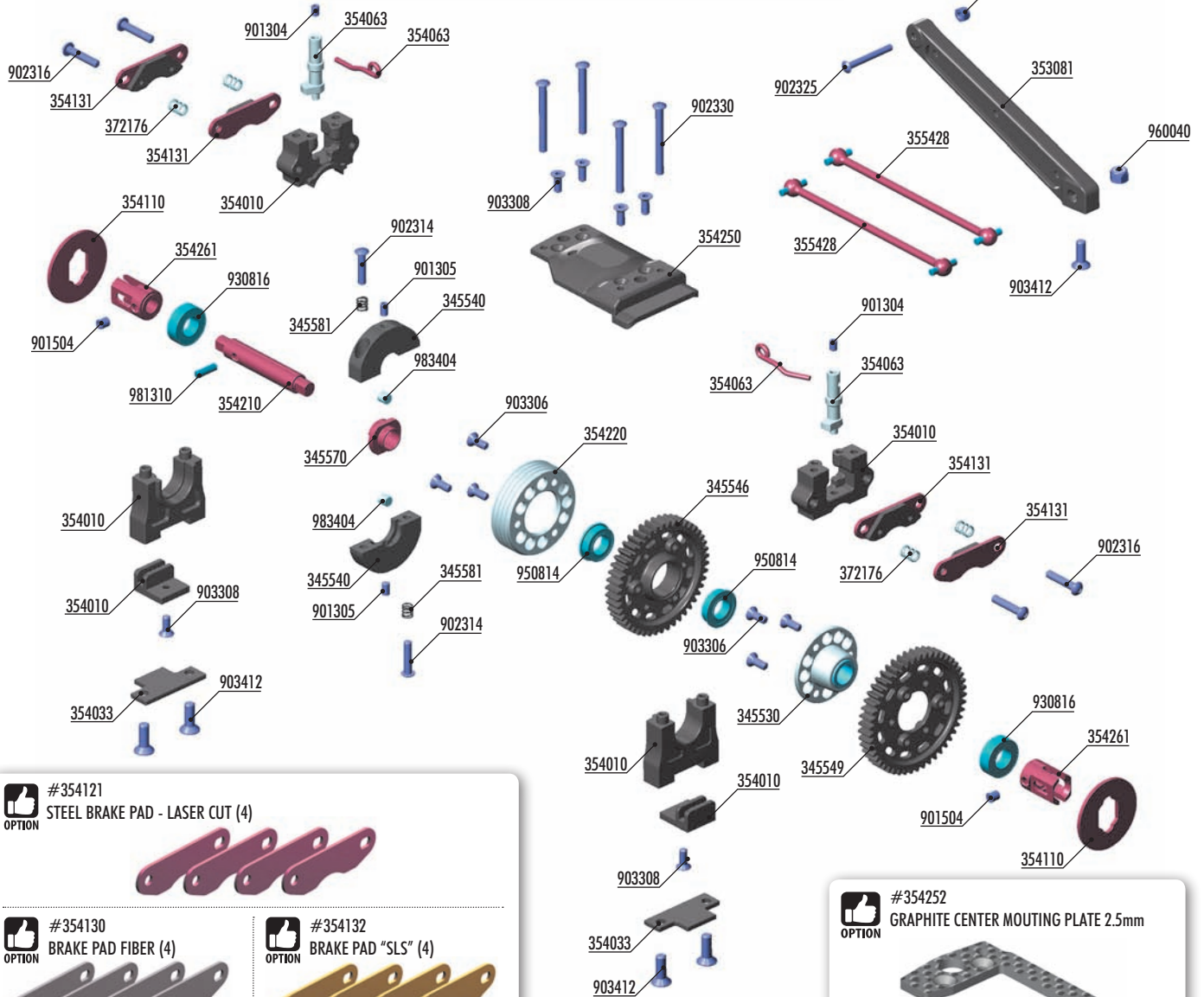

**OPTION**  
**#354121**  
STEEL BRAKE PAD - LASER CUT (4)



**OPTION**  
**#354130**  
BRAKE PAD FIBER (4)



**OPTION**  
**#354132**  
BRAKE PAD "SLS" (4)



**!** **CA** It is necessary to glue the brake pad with strong CA glue suitable for steel.

**OPTION**  
**#354252**  
GRAPHITE CENTER MOUNTING PLATE 2.5mm



**BAG**

**08**

345530 ALU DRIVE FLANGE WITH ONE-WAY BEARING - SWISS 7075 T6  
 345540 COMPOSITE 2-SPEED GEAR BOX SHOE - SET  
 345546 COMPOSITE 2-SPEED GEAR 46T (2nd) - H  
 345549 COMPOSITE 2-SPEED GEAR 49T (1st)  
 345570 ADAPTER 2-SPEED  
 345581 GEAR BOX SPRING C=13.0 (2)  
 353081 COMPOSITE REAR BRACE  
 354010 CENTER DIFF MOUNTING PLATE - SET  
 354033 COMPOSITE 2-SPEED HOLDER PLATE (2)  
 354063 ALU BRAKE CAM POST & ROD (2+2) HARD COATED  
 354110 VENTILATED BRAKE DISK - LASER CUT - PRECISION-GROUND  
 354131 GLUED BRAKE PADS SET-ULTRA EFFICIENT (4)  
 354210 2-SPEED SHAFT - HUDY SPRING STEEL™  
 354220 CARRIER FOR 2-SPEED GEAR (2nd) - SWISS 7075 T6  
 354250 COMPOSITE 2-SPEED UPPER PLATE  
 354261 CENTRAL TRANSM. OUTDRIVE ADAPTER - HUDY SPRING STEEL™ (2)  
 355428 FRONT CENTRAL DOGBONE DRIVE SHAFT 93MM - HUDY SPRING STEEL™  
 372176 SPRING 4.25 COILS 3.6x6x0.4MM; C=1.5 - GOLD (SOFT) (2)

901304 HEX SCREW SB M3x4 (10)  
 901305 HEX SCREW SB M3x5 (10)  
 901504 HEX SCREW SB M5x4 (10)  
 902314 HEX SCREW SH M3x14 (10)  
 902316 HEX SCREW SH M3x16 (10)  
 902325 HEX SCREW SH M3x25 (10)  
 902330 HEX SCREW SH M3x30 (10)  
 903306 HEX SCREW SFH M3x6 (10)  
 903308 HEX SCREW SFH M3x8 (10)  
 903412 HEX SCREW SFH M4x12 (10)  
 930816 BALL-BEARING 8x16x5 RUBBER SEALED - OIL (2)  
 950814 BALL-BEARING 8x14x4 FLANGED - STEEL SEALED - OIL (2)  
 960030 NUT M3 (10)  
 960040 NUT M4 (10)  
 981310 PIN 3x10 (10)  
 983404 ROLLER PIN 4x4 MM (2)

# 8. CENTER DIFF & BRAKE



902316  
SH M3x16

2x F=R

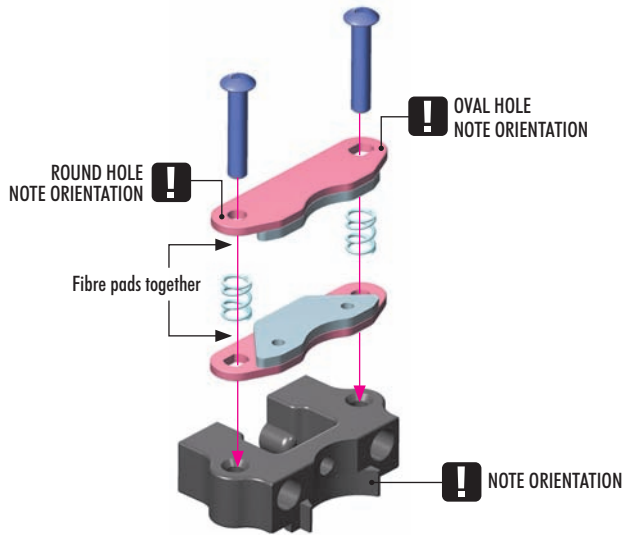

Temporarily insert brake disk between pads to set correct gap.

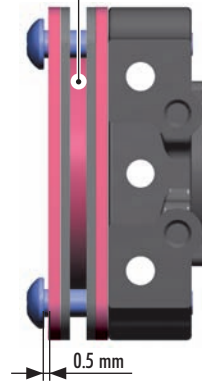

#354121  
STEEL BRAKE PAD - LASER CUT (4)



#354130  
BRAKE PAD FIBER (4)



#354132  
BRAKE PAD "SLS" (4)



It is necessary to glue the brake pad with strong CA glue suitable for steel.



ASSEMBLY VIEW

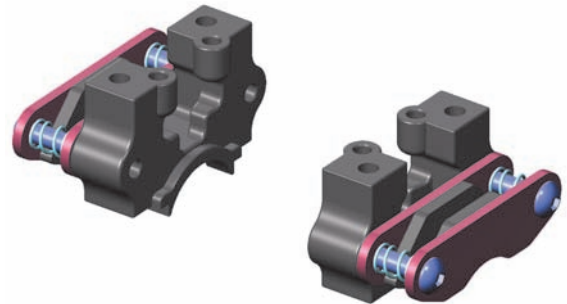

901304  
SB M3x4



903308  
SFH M3x8

NOTE ORIENTATION

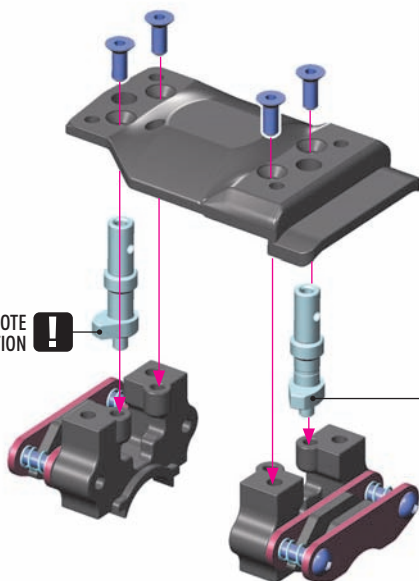

NOTE ORIENTATION

NOTE ORIENTATION

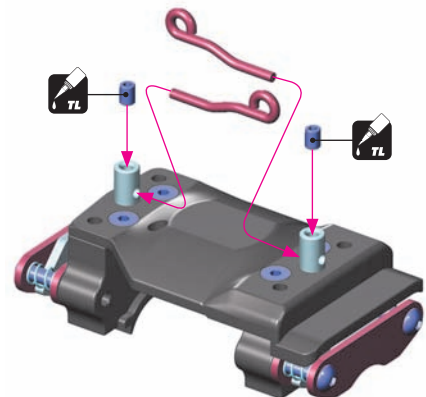
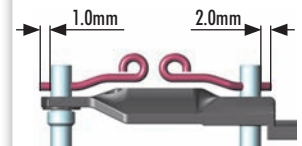
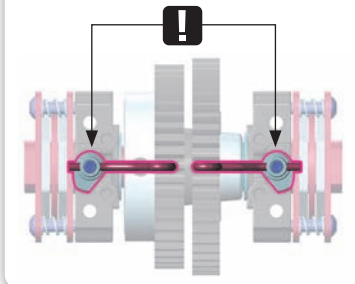

# 8. CENTER DIFF & BRAKE



903308  
SFH M3x8

**!**  
NOTE ORIENTATION  
OF ALL PARTS

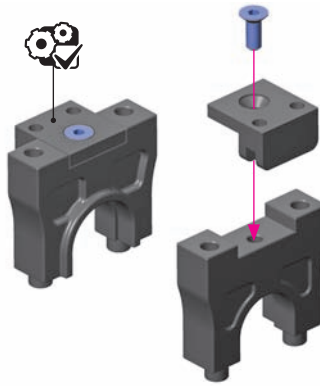

#354010-G  
COMPOSITE CENTER DIFFERENTIAL  
MOUNTING PLATE SET - GRAPHITE



903412  
SFH M4x12

**!** NOTE ORIENTATION

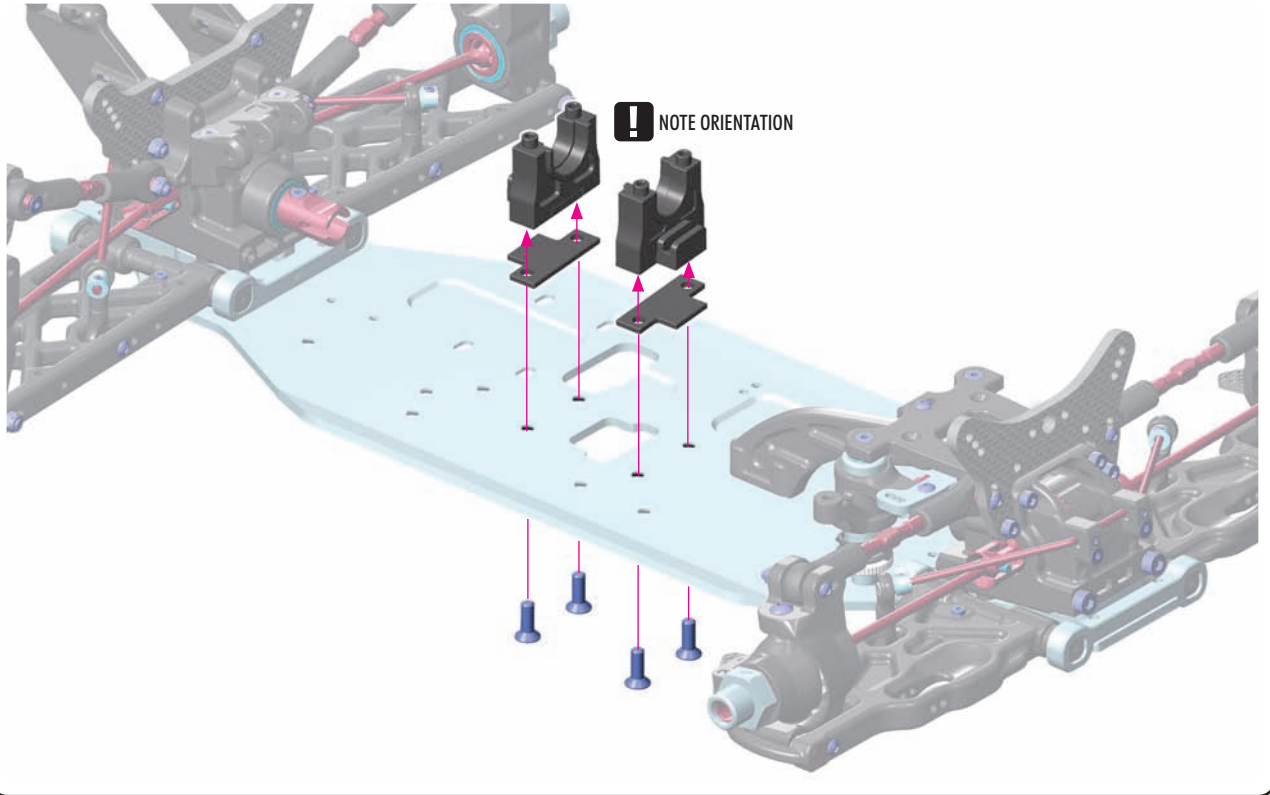

901305  
SB M3x5

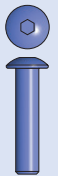

902314  
SH M3x14



983404  
RP 4x4

**!** NOTE ORIENTATION

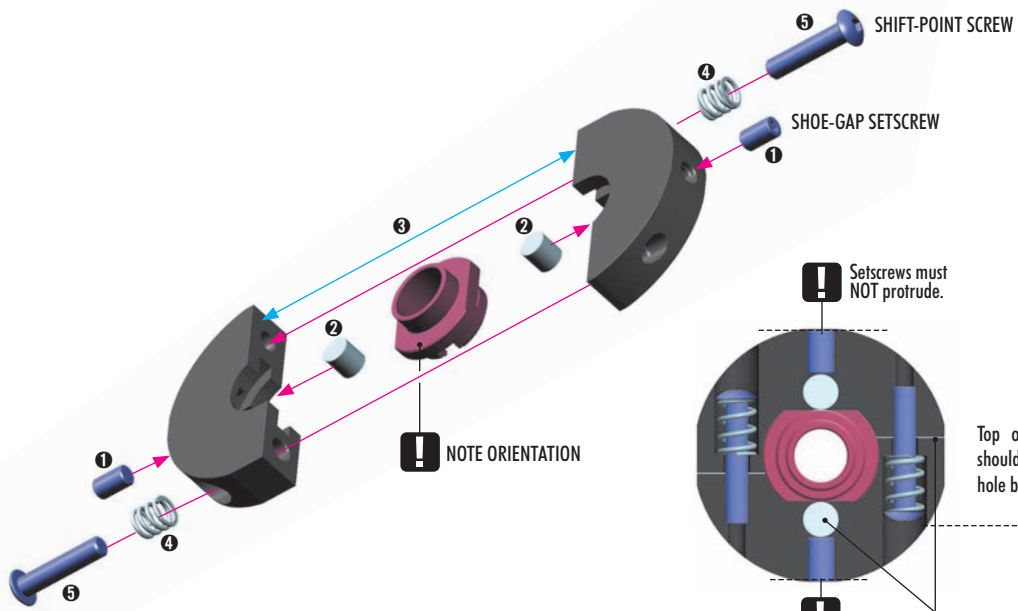

**!** Setscrews must  
NOT protrude.

Top of screw head  
should be level with  
hole bottom edge.

**!** Do not overtighten gap-setting  
setscrews. Only tighten until roller  
pins contact the center hub.



2-SPEED TRANSMISSION

# 8. CENTER DIFF & BRAKE



950814  
BB 8x14x4



903306  
SFH M3x6

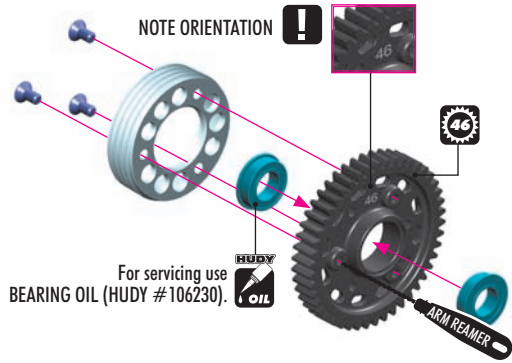

Use HUDY Reamer #107600 to slightly chamfer the edges on all 3 holes for screws from inside. **TIP**



903306  
SFH M3x6

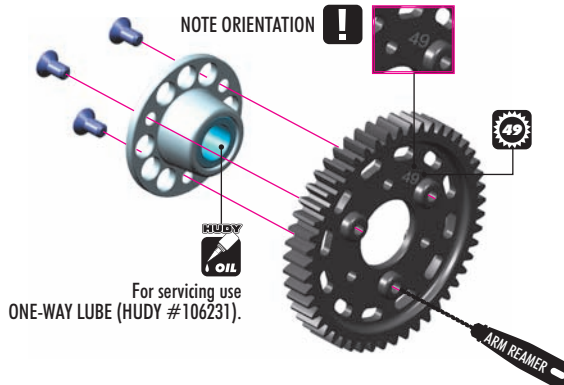

Use HUDY Reamer #107600 to slightly chamfer the edges on all 3 holes for screws from inside. **TIP**



901504  
SB M5x4

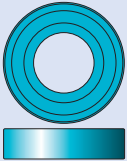

930816  
BB 8x16x5

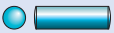

981310  
P 3x10

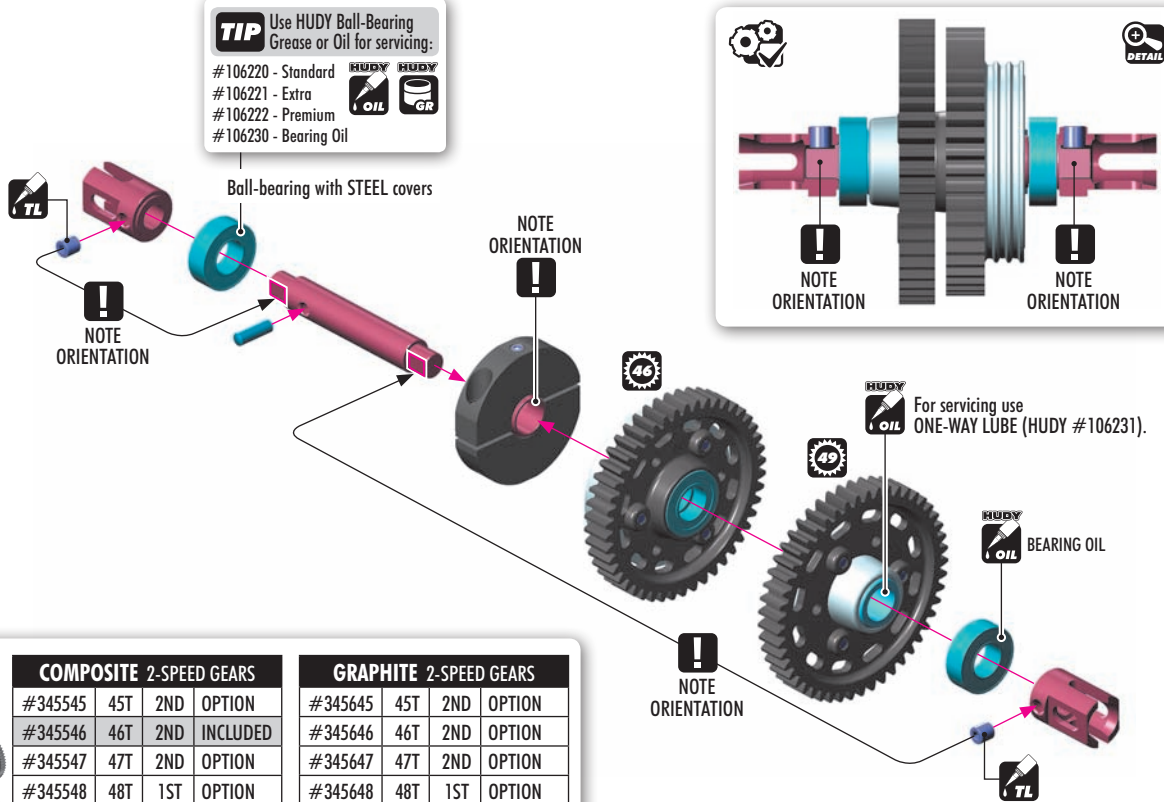

OPTION	COMPOSITE 2-SPEED GEARS				GRAPHITE 2-SPEED GEARS			
	#345545	45T	2ND	OPTION	#345645	45T	2ND	OPTION
	#345546	46T	2ND	INCLUDED	#345646	46T	2ND	OPTION
	#345547	47T	2ND	OPTION	#345647	47T	2ND	OPTION
	#345548	48T	1ST	OPTION	#345648	48T	1ST	OPTION
	#345549	49T	1ST	INCLUDED	#345649	49T	1ST	OPTION
	#345550	50T	1ST	OPTION	#345650	50T	1ST	OPTION

# 8. CENTER DIFF & BRAKE



902330  
SH M3x30

**RUBBY OIL**  
All screws

**OPTION** #354113  
SUPER-LIGHTWEIGHT VENTILATED BRAKE DISK - PRECISION-GROUND (2)

**!**  
NOTE ORIENTATION OF ALL PARTS

**REAR**

Before inserting 3x30 long screws, loosen the four flat-head screws in the upper plate by 1/2 turn (CCW). Tighten all screws after assembly.

**FRONT**



902325  
SH M3x25



903412  
SFH M4x12



960030  
N M3



960040  
N M4

**OPTION** #353281  
GT GRAPHITE BRACES FOR REAR COMPOSITE BRACE - SET for extra stiffness adjustment.

960030

353281

353281

902312

# 9. FUEL TANK & ENGINE



## 1ST PINION GEAR XCA HARD COATED

#348515	15T	OPTION
#348516	16T	INCLUDED
#348517	17T	OPTION
#348518	18T	OPTION



## 2ST PINION GEAR XCA HARD COATED

#348519	19T	INCLUDED
#348520	20T	OPTION
#348521	21T	OPTION



#670001 FX G501 COMBO  
#670101 FX G501 ENGINE  
#679500 FX MUFFLER + MANIFOLD

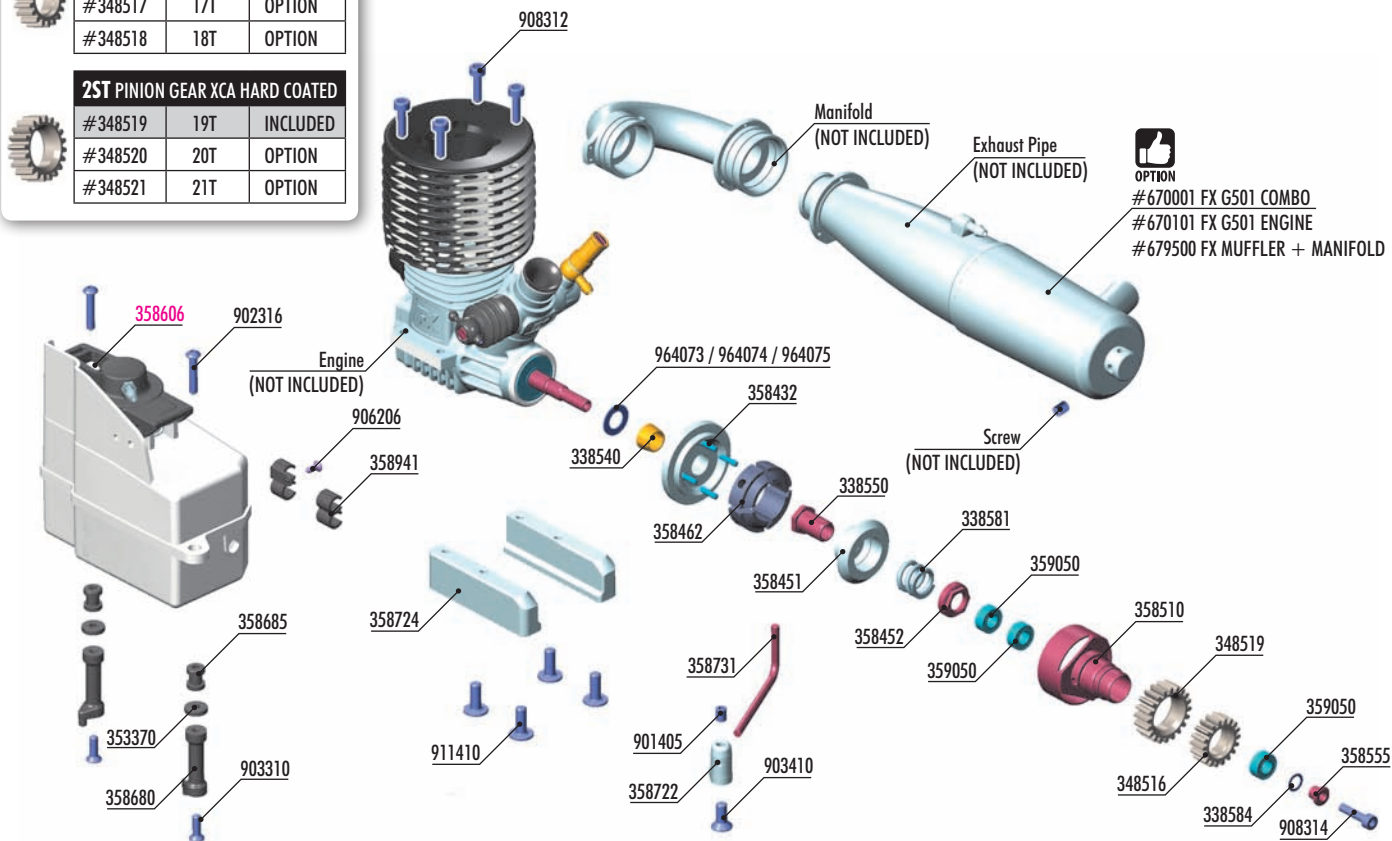

#358661 GRAPHITE 150CC FUEL TANK GUARD



#358709 ALU MONOBLOCK ENGINE MOUNT



## ALU STAND FOR ENGINE MOUNT

#358718	FX, NOVAROSS, MAX, SIRIO	OPTION
#358719	PICCO, REDS, ORION, LRP, OS, U. RACING	OPTION



#358400 XRAY COMPLETE 4-SHOE CLUTCH SET



## 4-SHOE CLUTCH SHOES

#	Material	Weight	GRIP	Option
#358457	ALU HARD (4)	1.00g	HIGH	OPTION
#358456	ALU MED (4)	1.00g	HIGH	OPTION
#358461	GRAPHITE (4)	1.00g	HIGH	OPTION
#358460	ALU HARD (4)	1.15g	HIGH	OPTION
#358459	ALU MEDIUM (4)	1.15g	HIGH	INCLUDED
#358458	ALU SOFT (4)	1.15g	LOW	OPTION



## CLUTCH SPRINGS (4pcs)

#	Material	Color	RPM	Option
#358480	SOFT	GOLD	EARLY	INCLUDED
#358481	MEDIUM	GREY	EARLY	OPTION
#358482	HARD	SILVER	LATE	OPTION



#358511 GT 2-SPEED 4-SHOE CLUTCH BELL - LIGHTWEIGHT



## BAG

09

338540	FLYWHEEL COLLAR 7MM	358731	EXHAUST MOUNTING WIRE - LONG
338550	FLYWHEEL NUT - HUDY SPRING STEEL™	358941	COMPOSITE TUBING HOLDER FOR FUEL TANK (2)
338581	CLUTCH SPRING - MEDIUM - V2	359050	BALL-BEARING 5x10x4 STEEL SEALED - GREASE (2)
338584	SHIM 5x7x0.2 (10)		
348516	XCA ALU 7075 T6 HARD COATED PINION GEAR - 16T (1ST)	901405	HEX SCREW SB M4x5 (10)
348519	XCA ALU 7075 T6 HARD COATED PINION GEAR - 19T (2ND)	902316	HEX SCREW SH M3x16 (10)
353370	SET OF COMPOSITE REAR HUB CARRIER SHIMS	903310	HEX SCREW SFH M3x10 (10)
358432	GT ALU 4-SHOE FLYWHEEL	903410	HEX SCREW SFH M4x10 (10)
358451	GT ALU 4-SHOE CLUTCH PRESSURE SLEEVE	906206	SCREW PHILLIPS FH 2.2x6 (10)
358452	GT 4-SHOE FLYWHEEL NUT	908312	HEX SCREW (CAP HEAD) 3x12 (10)
358462	GT COMPOSITE CLUTCH 4-SHOE - GRAPHITE	908314	HEX SCREW (CAP HEAD) 3x14 (10)
358510	GT 2-SPEED CLUTCH BELL - LIGHTWEIGHT	911410	HEX SCREW FLANGED SH M4x10 (10)
358555	GT CLUTCH BELL BUSHING - HUDY SPRING STEEL™	964073	WASHER S 7x10x0.2 (10)
358680	FUEL TANK MOUNTING POST (2)	964074	WASHER S 7x10x0.3 (10)
358685	FUEL TANK MOUNTING GROMMET (4)	964075	WASHER S 7x10x0.5 (10)
358722	EXHAUST WIRE MOUNT SET - LONG		
358724	ALU ENGINE MOUNT - CNC MACHINED (L+R)	358606	FUEL TANK 150CC WITH FLOATING FILTER & TRANSIENT JET

# 9. FUEL TANK & ENGINE

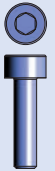

908312  
SCH M3x12



964073  
57x10x0.2



964074  
57x10x0.3



964075  
57x10x0.5

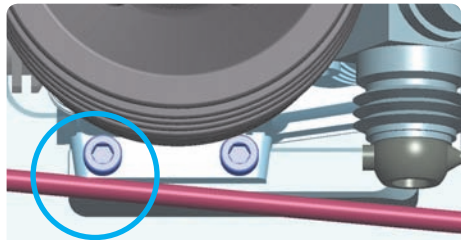

**!** IMPORTANT!

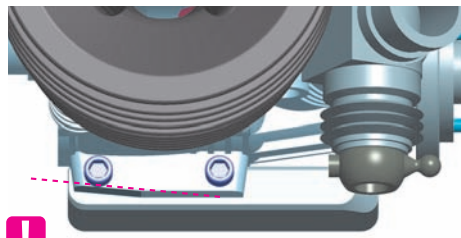

**!** When installing the engine, first check that the drive shaft does not touch the engine. If it does, remove some material from the engine mount as shown to make some room between engine and shaft.

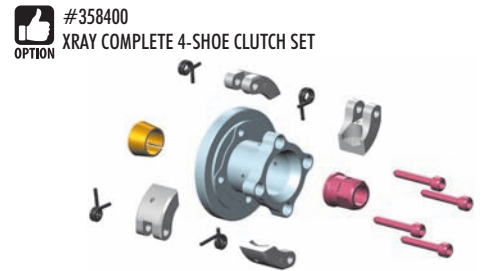
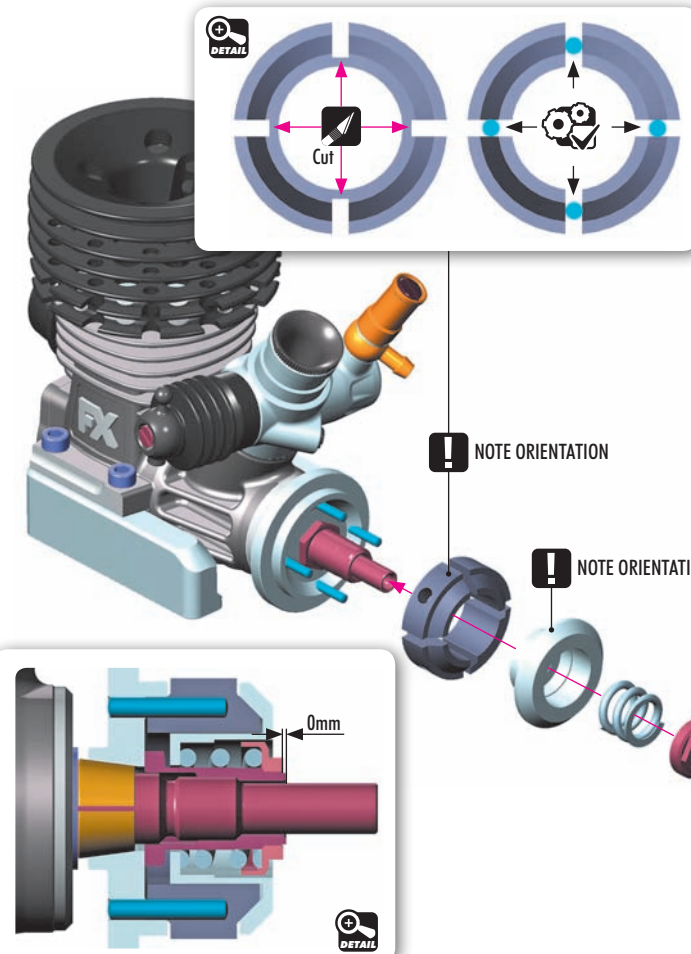
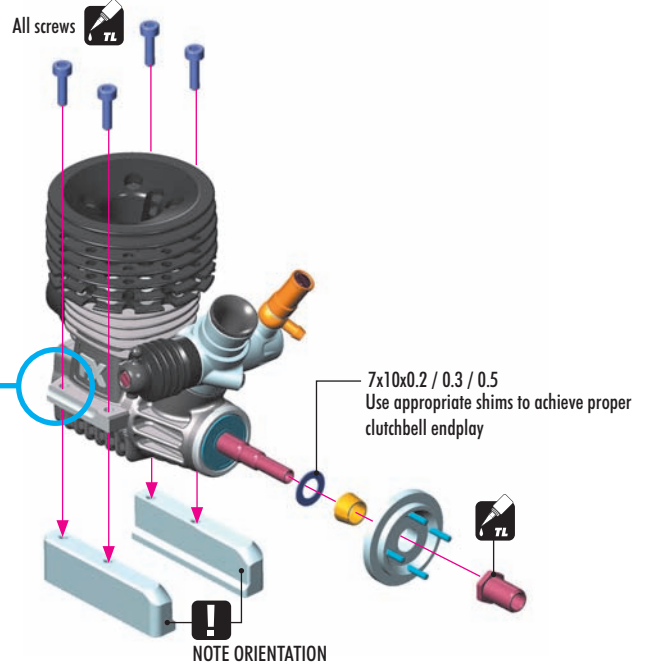

OPTION	4-SHOE CLUTCH SHOES		GRIP	
	Part #	Weight		
	#358457	ALU HARD (4)	1.00g	HIGH OPTION
	#358456	ALU MED (4)	1.00g	OPTION
	#358461	GRAPHITE (4)	1.00g	OPTION
	#358460	ALU HARD (4)	1.15g	OPTION
	#358459	ALU MEDIUM (4)	1.15g	INCLUDED
	#358458	ALU SOFT (4)	1.15g	LOW OPTION

OPTION	CLUTCH SPRINGS (4pcs)		RPM	
	Part #	Material		
	#358480	SOFT	GOLD	EARLY INCLUDED
	#358481	MEDIUM	GREY	OPTION
	#358482	HARD	SILVER	LATE OPTION



# 9. FUEL TANK & ENGINE



338584  
S 5x7x0.2



359050  
BB 5x10x4

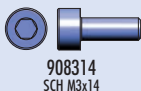

908314  
SCH M3x14



#358511  
GT 2-SPEED 4-SHOE CLUTCH BELL -  
LIGHTWEIGHT



**!** Optional part for #358400  
XRAY COMPLETE 4-SHOE CLUTCH SET.



### 1ST PINION GEAR XCA HARD COATED

#348515	15T	OPTION
#348516	16T	INCLUDED
#348517	17T	OPTION
#348518	18T	OPTION



### 2ST PINION GEAR XCA HARD COATED

#348519	19T	INCLUDED
#348520	20T	OPTION
#348521	21T	OPTION



**TIP**

TO TIGHTEN THE 16T OR 19T PINION GEAR  
USE THE OPTIONAL #349901 XRAY PINION  
TOOL (19~21T / 16~18T).



These bearings must still  
be regularly serviced and  
replaced when worn out.



### SET-UP BOOK

CLUTCH SPRINGS  
CLUTCH SHOE



911410  
SHF M4x10

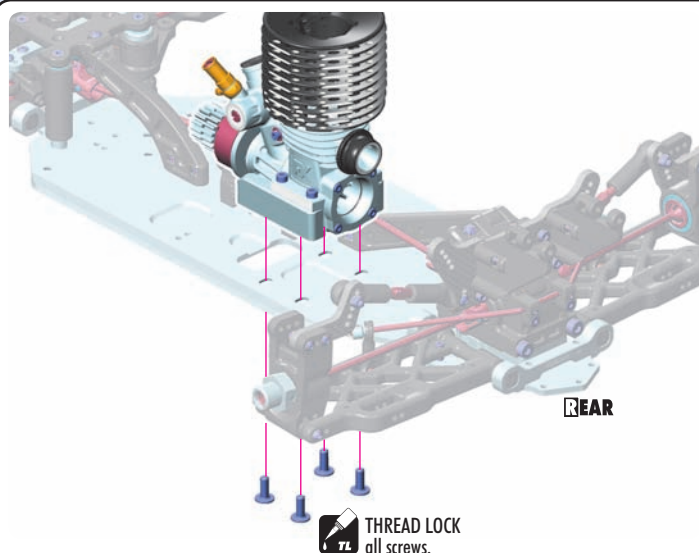

### GEAR MESH

Adjust gear mesh so there is minimal  
play between the gears.

Too tight gear mesh will put excessive  
strain on all parts and damage the  
parts. Too loose gear mesh may result  
in stripped gears.

### SET-UP BOOK

GEARING  
GEAR MESH ADJ.



907258  
SP 2.5x8

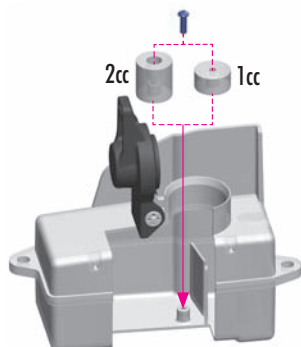

The fuel tank has the larger fuel volume and includes OPTIONAL tank inserts for decreasing the volume of the tank. Using the inserts allows you to adjust the volume of fuel inside the tank; this works in conjunction with variables such as fuel filter capacity and/or length of fuel line to ensure you have the legal fuel volume limit for racing.

Tube holders are easily connected to the fuel tank by screws. Using screws is much more secure than using glue to attach the holders to the fuel tank.

### 2CC FUEL TANK INSERT

The larger insert decreases the fuel tank volume by 2cc, and is recommended for use when the fuel filter is used.



NOTE ORIENTATION



### 1CC FUEL TANK INSERT

The smaller insert decreases the fuel tank volume by 1cc.



NOTE ORIENTATION



NOTE: The fuel tank insert can be easily mounted to the bottom of the fuel tank using the provided screw, when the fuel tank cap is opened fully.

# 9. FUEL TANK & ENGINE



353370  
SHIM 3x9x2



902316  
SH M3x16



903310  
SFH M3x10



906206  
SFP 2.2x6

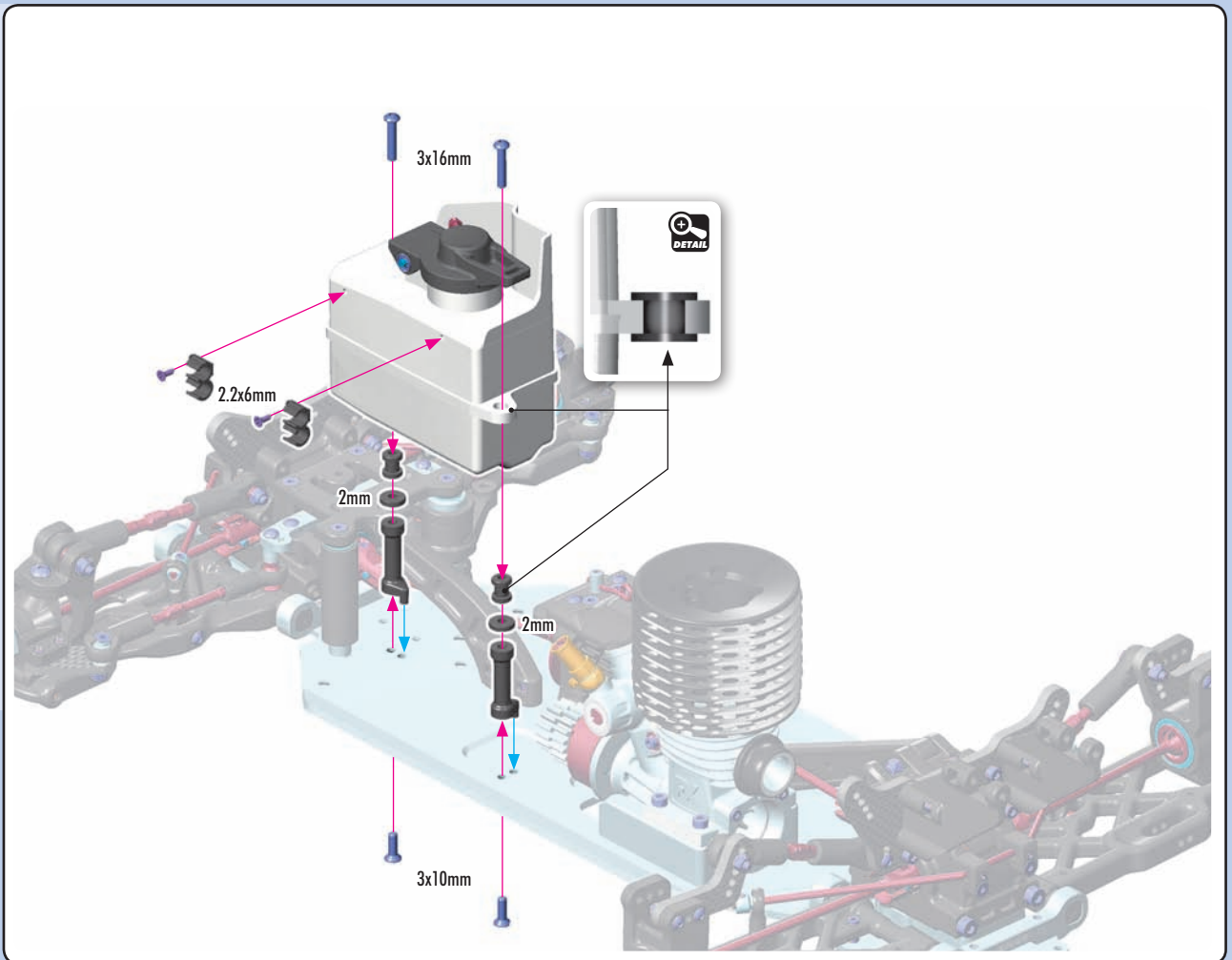

901405  
SB M4x5



903410  
SFH M4x10

**TIP** After running your engine, apply (#106250 HUDY ENGINE AFTER RUN OIL).

Bend the exhaust wire as appropriate to fit the muffler. **!**

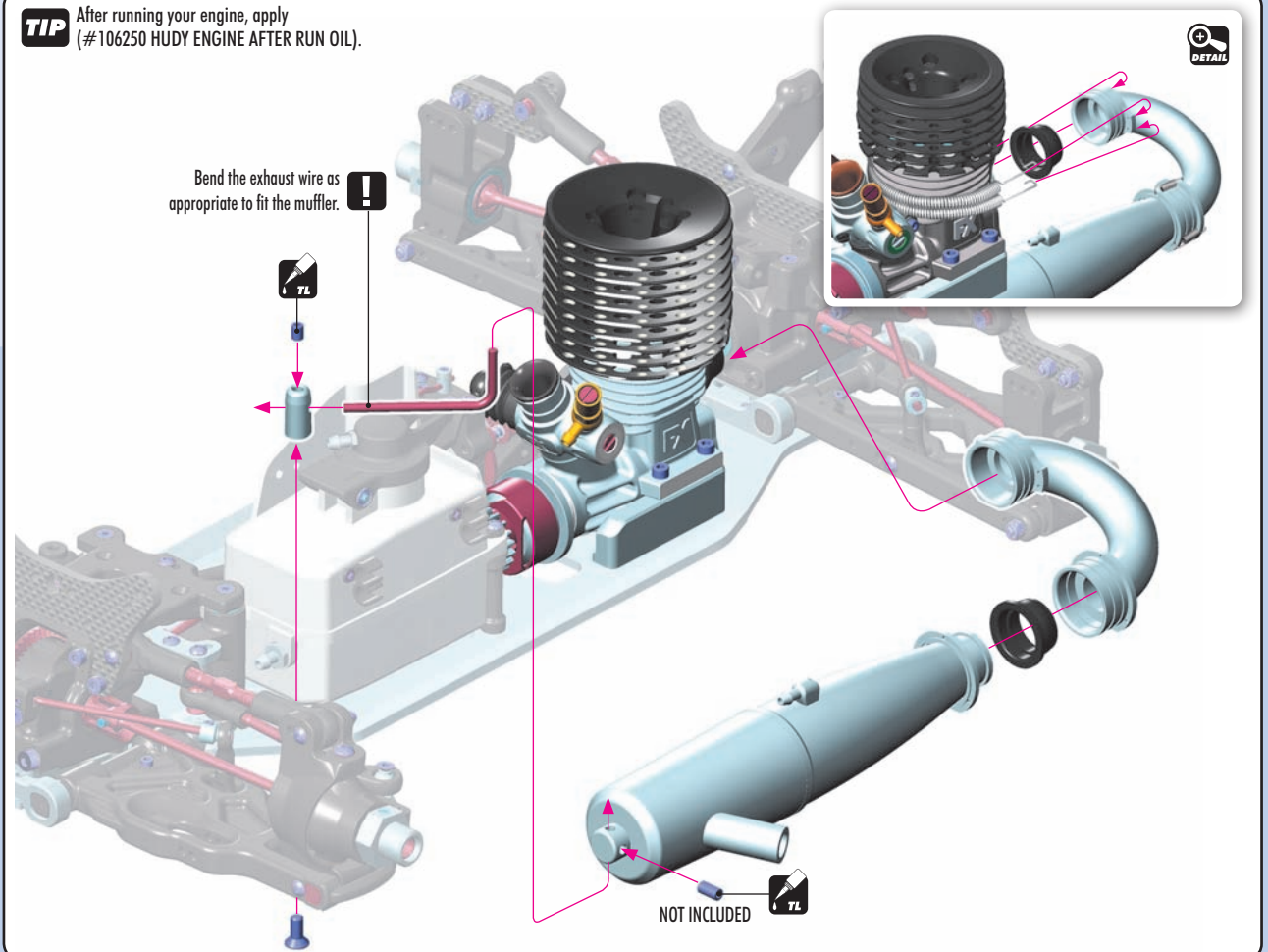

# 10. RADIO CASE

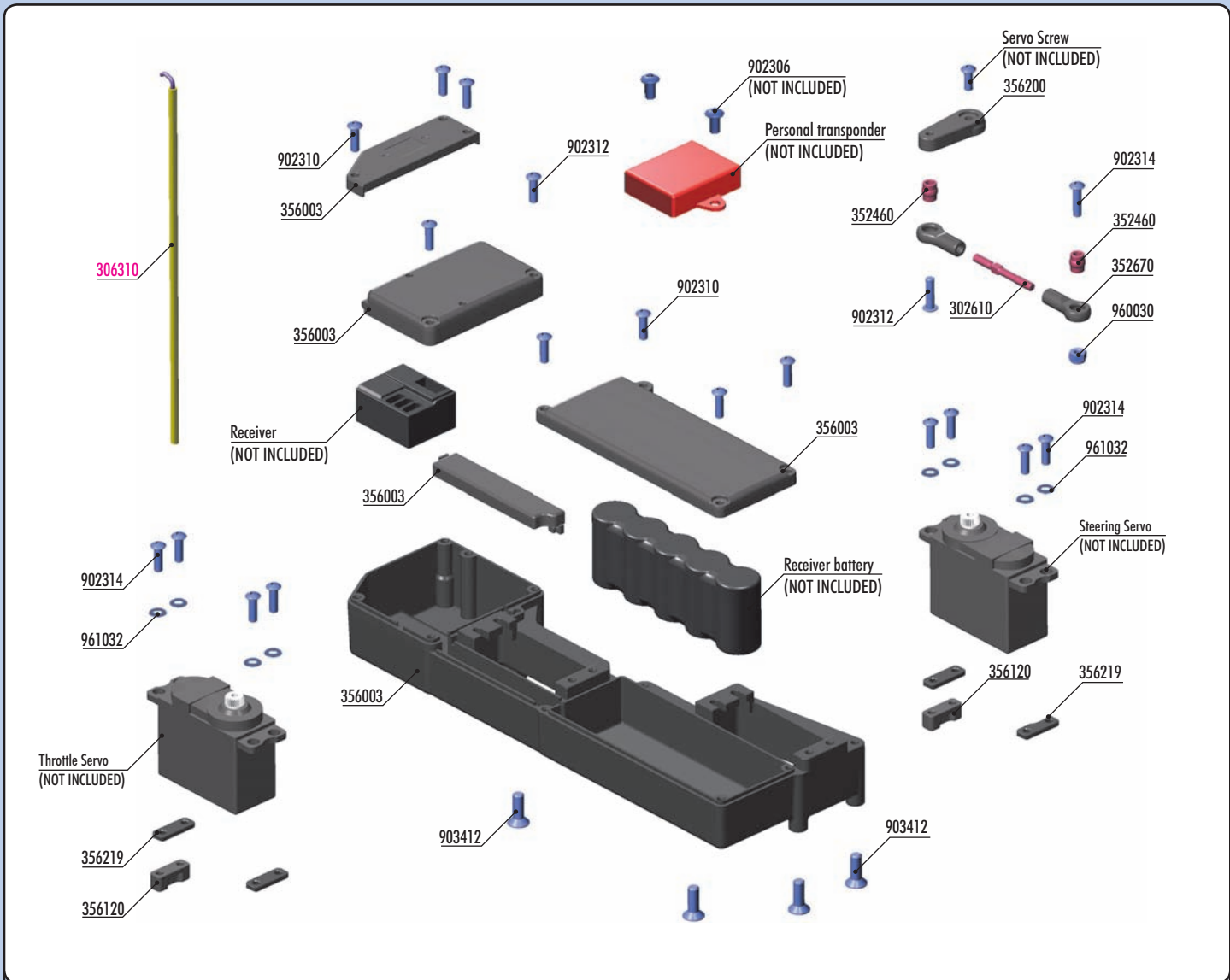

**BAG**



- 302610 ADJ. TURNBUCKLE M3 L/R 39MM - HUDY SPRING STEEL™ (2)
- 352460 PIVOT BALL 5.8 (10)
- 352670 SERVO BALL JOINT 5.8MM (4)
- 356003 COMPOSITE RADIO CASE SET
- 356050 BATTERY CABLE WITH SWITCH (OPTION)
- 356120 STEERING SERVO MOUNT - SET
- 356200 BRAKE/THROTTLE ARMS & STEERING SERVO ARMS - SET
- 356219 COMPOSITE SERVO SHIMS 1.0, 1.5 & 2.5MM (2+2+2)
- 389135 CONNECTING CABLE RECEIVER/BATT. PACK (OPTION)

- 902306 HEX SCREW SH M3x6 (10) (OPTION)
- 902310 HEX SCREW SH M3x10 (10)
- 902312 HEX SCREW SH M3x12 (10)
- 902314 HEX SCREW SH M3x14 (10)
- 903412 HEX SCREW SFH M4x12 (10)
- 960030 NUT M3 (10)
- 961032 WASHER S 3.2 (10)

**306310 ANTENNA TUBE (2)**



902312 SH M3x12

**TIP** Install the all pivot balls with Professional Multi Tool (HUDY #183011).

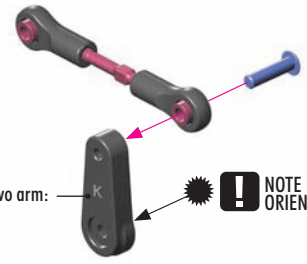
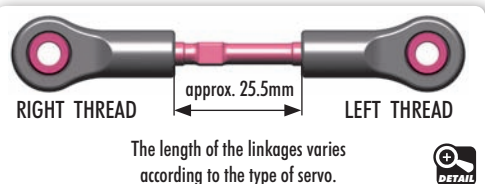
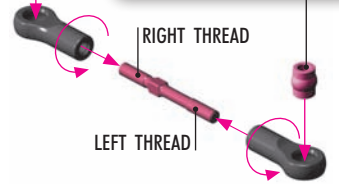

CLAMP ALU SERVO HORNS			
#293407	23T	OPTION	
#293408	24T	OPTION	
#293409	25T	OPTION	

ALU SERVO HORNS			
#293501	23T	OPTION	
#293502	24T	OPTION	
#293503	25T	OPTION	

# 10. RADIO CASE



902314  
SH M3x14



961032  
S 3.2

**step 1**

Servo screw (NOT INCLUDED)

**TOP**

Plug the connectors into the receiver in Step 2.

**BOTTOM**

**NOTE**  
ORIENTATION

**NOTE**  
Use the shims only if the servo is too high and extends from the case.



902310  
SH M3x10



902312  
SH M3x12



907206  
SP M2x6

**step 2**

Use foam to cushion the inside of the radio case so the receiver and battery cannot vibrate or move.

3x10mm

3x12mm

3x10mm

**TIP** **CUT**

2x6

**SWITCH #356050**  
OPTION

When receiver switch is used, use hobby knife to CAREFULLY remove the material from the cover and mount the switch.



902314  
SH M3x14



903412  
SFH M4x12



960030  
N M3

Personal transponder (NOT INCLUDED)  
#902306 Screws (NOT INCLUDED)

Personal transponder can be placed on the top of the radio box or inside of the radio box.

**ALTERNATIVE 1**  
When the transponder is placed at the top of the radio box, cut out some material from the radio box in order to allow the transponder wire to come inside.

**ALTERNATIVE 2**  
Place the transponder inside of the radio box by using double-sided tape.

3x6mm (NOT INCLUDED)

3x14mm

4x12mm

4x12mm

**DETAIL**

Note orientation of servo arm when servo is at neutral.

# 11. SHOCK ABSORBERS

## PISTONS

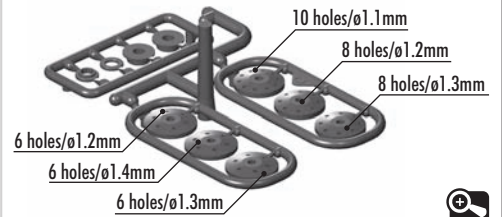

#358196  
XRAY GT SPRING SET C=6.0, 3 DOTS (2)

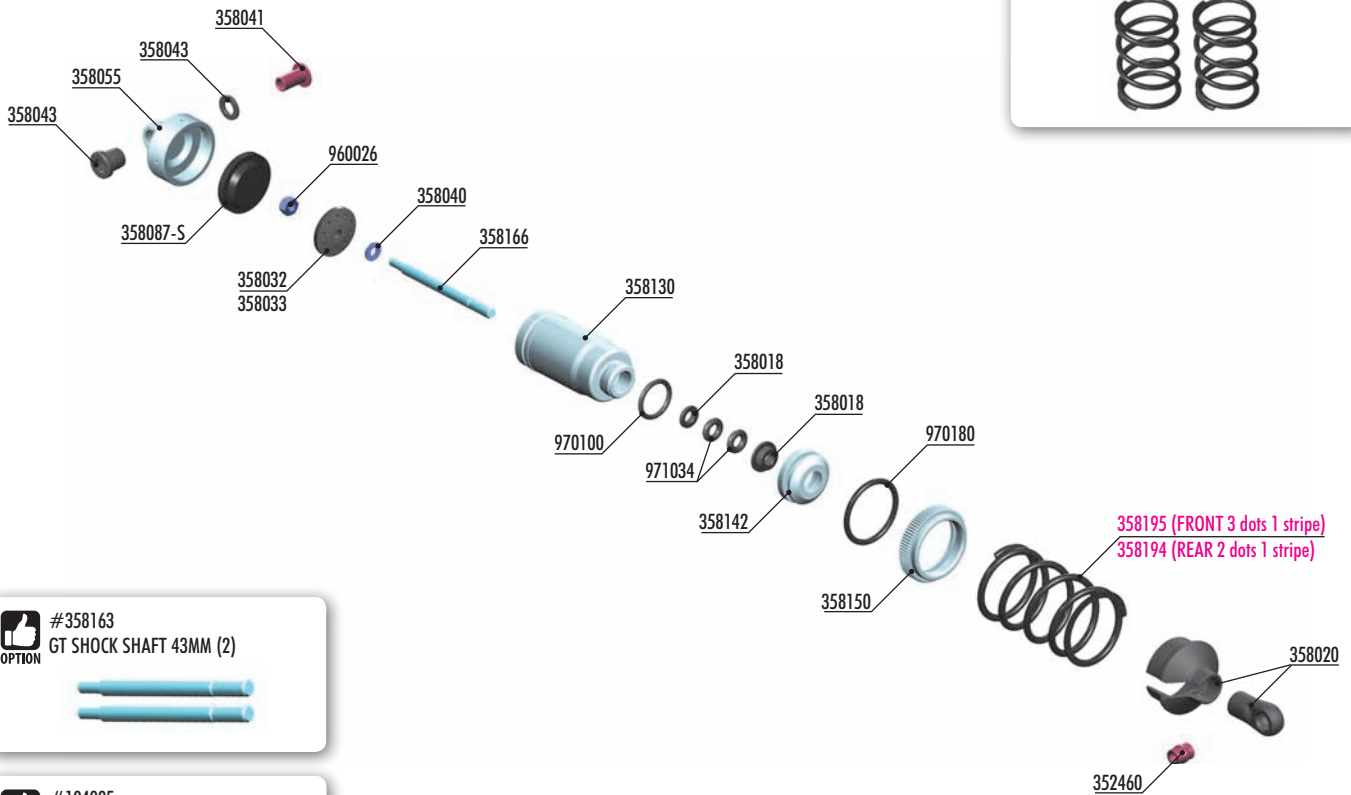

#358163  
GT SHOCK SHAFT 43MM (2)



#104005  
HUDY AIR VAC - VACUUM PUMP  
- 1/8 OFF-ROAD



### SHOCK RUBBER MEMBRANE (4)

#358084	RIBBED	MEDIUM	OPTION	
#358084-S	RIBBED	SOFT	OPTION	
#358087-S	CELL	SOFT	INCLUDED	
#358087-M	CELL	MEDIUM	OPTION	



- #358027 PISTON 5-HOLE (1.5mm) & 2-HOLE (1.0mm) (4)
- #358028 PISTON 6-HOLE (1.3mm) & 2-HOLE (1.1mm) (4)
- #308029 PISTON 6-HOLE (1.4mm) & 2-HOLE (1.1mm) (4)
- #358030 PISTON 8-HOLE (1.2mm) & 2-HOLE (1.2mm) (4)
- #358031 PISTON 8-HOLE (1.3mm) & 2-HOLE (1.2mm) (4)



#358054  
XB8 ALU SHOCK CAP NUT WITH  
VENT HOLE - BLACK COATED (2)



## BAG

11

- 352460 PIVOT BALL 5.8 - V3 (10)
- 358018 COMPOSITE SET OF SHIMS FOR SHOCKS - (2)
- 358020 COMPOSITE SHOCK PARTS
- 358032 SHOCK PISTON SET 8-HOLE (1.2; 1.3) 10-H. (1.1MM) - DELRIN - V2
- 358033 COMPOSITE SHOCK 6-HOLE PISTON SET (1.2; 1.3; 1.4MM) - DELRIN - V2
- 358040 HARDENED SHOCK SHIMS (4)
- 358041 STEEL SHOCK BUSHING (2)
- 358043 COMPOSITE SHOCK BUSHING & SHIM (2+2)
- 358055 ALU SHOCK CAP NUT - BLACK COATED (2)
- 358087-S SHOCK RUBBER MEMBRANE CELL - SOFT (4)
- 358130 GT ALU SHOCK BODY - V2 (2)
- 358142 ALU SHOCK BODY NUT FOR SHOCK BOOT (2)

- 358150 ALU SHOCK BODY ADJ. NUT (2)
- 358166 GT SHOCK SHAFT 46MM (2)
- 960026 NUT M2.5 - SHORT (10)
- 970100 O-RING 10 x 1.5 (10)
- 970180 O-RING 18 x 1.8 (10)
- 971034 SILICONE O-RING 3.5x2 (10)

- 358194 XRAY GT PROGRESSIVE SPRING SET C=4.1-4.7, 2-DOTS WITH STRIPE (2)
- 358195 XRAY GT PROGRESSIVE SPRING SET C=5.2-5.8, 3-DOTS WITH STRIPE (2)

# 11. SHOCK ABSORBERS

358040  
S 2.5x6x0.5

960026  
N M2.5

4x

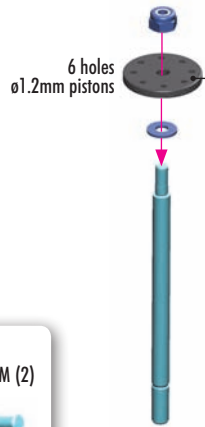

#358163  
OPTION  
GT SHOCK SHAFT 43MM (2)

DETAIL

Install the piston with Professional Multi Tool (HUDY #183011).



DETAIL

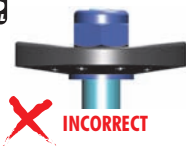

INCORRECT



DO NOT OVERTIGHTEN

The self-locking nut is overtightened, causing distortion of the piston. This will negatively affect the free movement of the piston in the shock body.

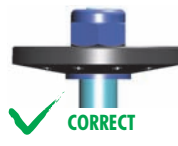

CORRECT



TIGHTEN GENTLY

The self-locking nut is gently tightened. The piston remains undistorted and fits inside the shock body perfectly, ensuring smooth movement of the piston.

**SET-UP BOOK**  
SHOCK DAMPING  
SHOCK PISTONS

970100  
O 10x1.5

971034  
O 3.4x2

4x

There are two different thickness shims, use them as shown. Use the same procedure when building both front and rear shocks.

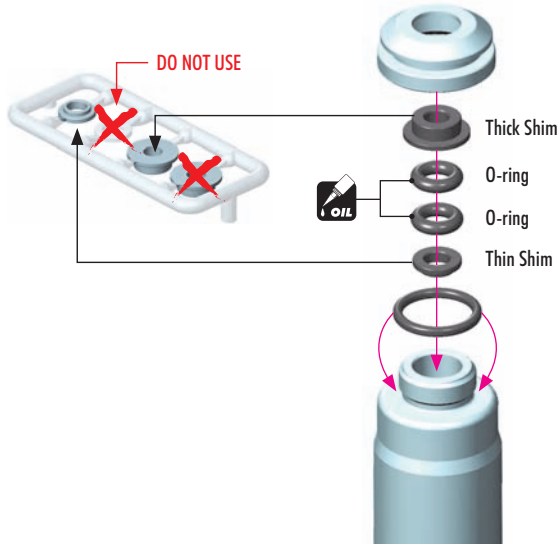

DETAIL

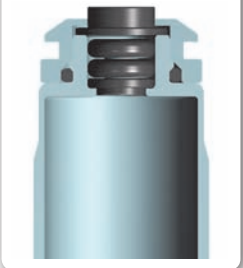

4x

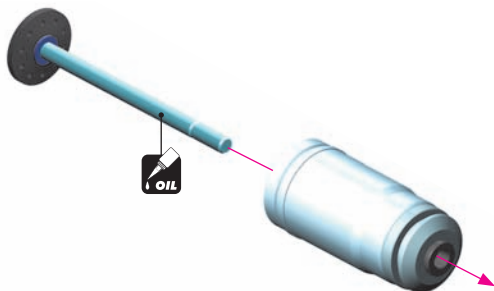

**EXTREMELY IMPORTANT**

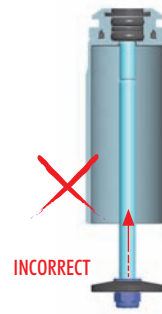

INCORRECT

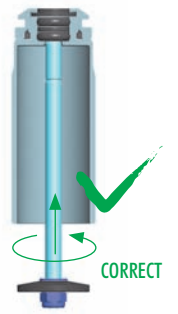

CORRECT

Do not push the shock rod straight through the lower shock body assembly; O-ring damage may result.

Twist the shock rod through the lower shock body assembly.

# 11. SHOCK ABSORBERS



970180  
Ø 18x1.8

4x

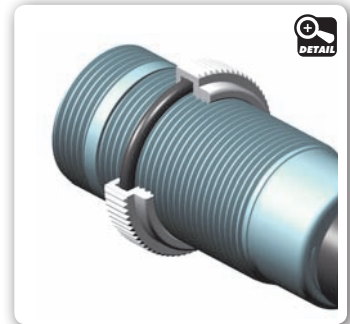
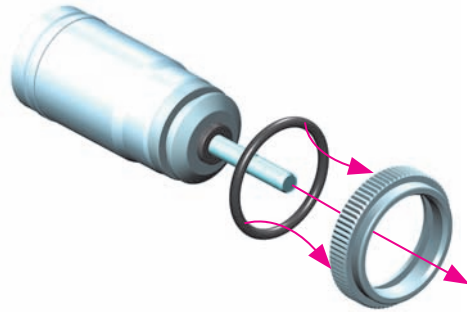

2x FRONT SHOCKS

2x REAR SHOCKS

Professional Multi Tool  
(HUDY #183011).

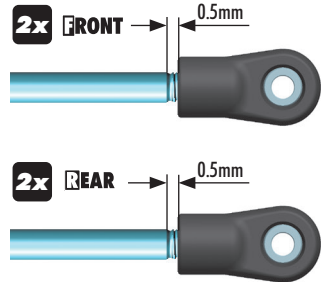
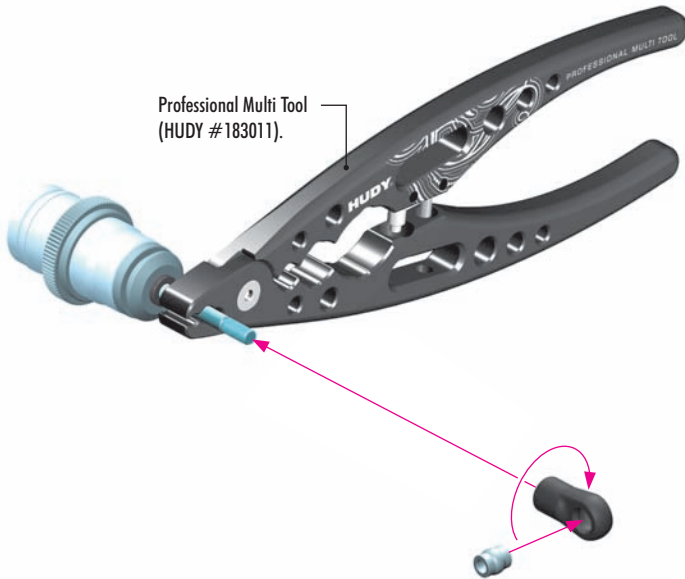

## DEFAULT SHOCK REBOUND SETTING 0% (LOW REBOUND)

Follow the steps below to set the shock rebound to the default setting of 0%.

4x SHOCK  
Oil 800cSt

SET-UP  
BOOK  
SHOCK OIL



1 Extend the shock shaft completely. Fill the shock body with the shock oil. For the shocks use 800cSt oil.



2 Move the shock shaft up and down a few times to release the air bubbles trapped beneath the piston.



3 Orient the filled shock vertically for several minutes with the shock shaft fully extended. The remaining air bubbles will release.

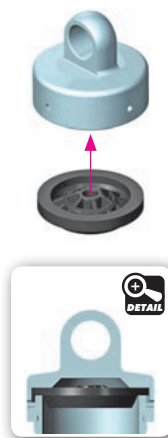

4 Install the shock membrane into the groove in the upper shock cap.



5 Gently place the shock cap assembly onto the filled shock body. Excess oil will spill from the shock. Screw the shock cap onto the body by only a few turns.

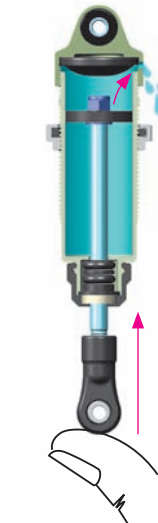

6 Gently push the shock shaft completely into the shock body. Excess oil will flow through the hole in the shock cap.



7 Keep the shock shaft pushed in the shock body and tighten the shock cap completely. The rebound will be at approximately 0%.

# 11. SHOCK ABSORBERS



971034  
0 3.4x2

4x

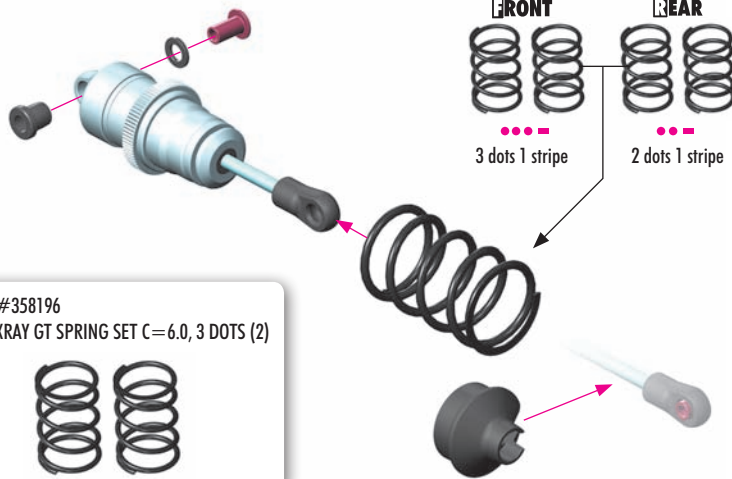

#358196  
XRAY GT SPRING SET C=6.0, 3 DOTS (2)

OPTION

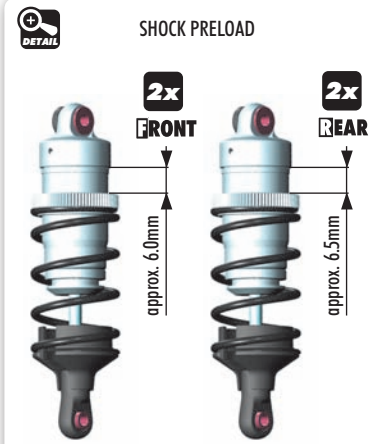

## SET-UP BOOK

SPRING RATE SHOCK  
PRELOAD  
RIDE HEIGHT

### TIP ALTERNATE SHOCK REBOUND SETTING (50% AND 100%)

The default shock rebound setting is 0% (as described on page 40).

Alternatively, you may set the shock rebound setting to 50% or 100% as described below. Remove the shock springs before performing shock rebound adjustment.

#### SETTING THE SHOCK REBOUND TO 50% (MEDIUM REBOUND)

##### REMOVE SHOCK CAP

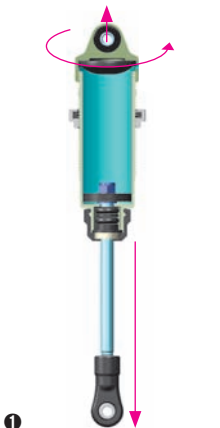

1 Extend the shock shaft completely and remove the shock cap.



2 Fill the shock body with shock oil up to the top. Make sure to use same viscosity shock oil as is in the shock.



3 Orient the filled shock vertically for several minutes with the shock shaft fully extended. The remaining air bubbles will release.

##### HALF TIGHTEN



4 Gently place the shock cap assembly onto the filled shock body. Excess oil will spill from the shock.

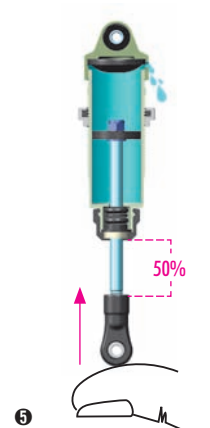

5 Push the shock shaft 50% into the shock body. Excess oil will bleed through the hole in the shock cap.

##### TIGHTEN FULLY

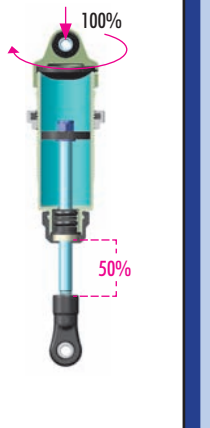

6 Keep the shock shaft pushed 50% into the shock body and tighten the shock cap completely. The rebound will be at approximately 50%.

#### SETTING THE SHOCK REBOUND TO 100% (HIGH REBOUND)

##### REMOVE SHOCK CAP

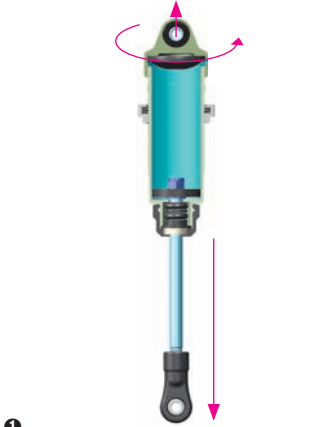

1 Extend the shock shaft completely and remove the shock cap.



2 Fill the shock body with shock oil up to the top. Make sure to use same viscosity shock oil as is in the shock.



3 Orient the filled shock vertically for several minutes with the shock shaft fully extended. The remaining air bubbles will release.

##### TIGHTEN FULLY

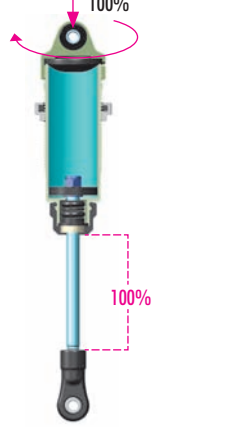

4 Gently place the shock cap assembly onto the filled shock body. Keep the shock shaft extended 100% from the shock body and tighten the shock cap completely. The rebound will be at approximately 100%.



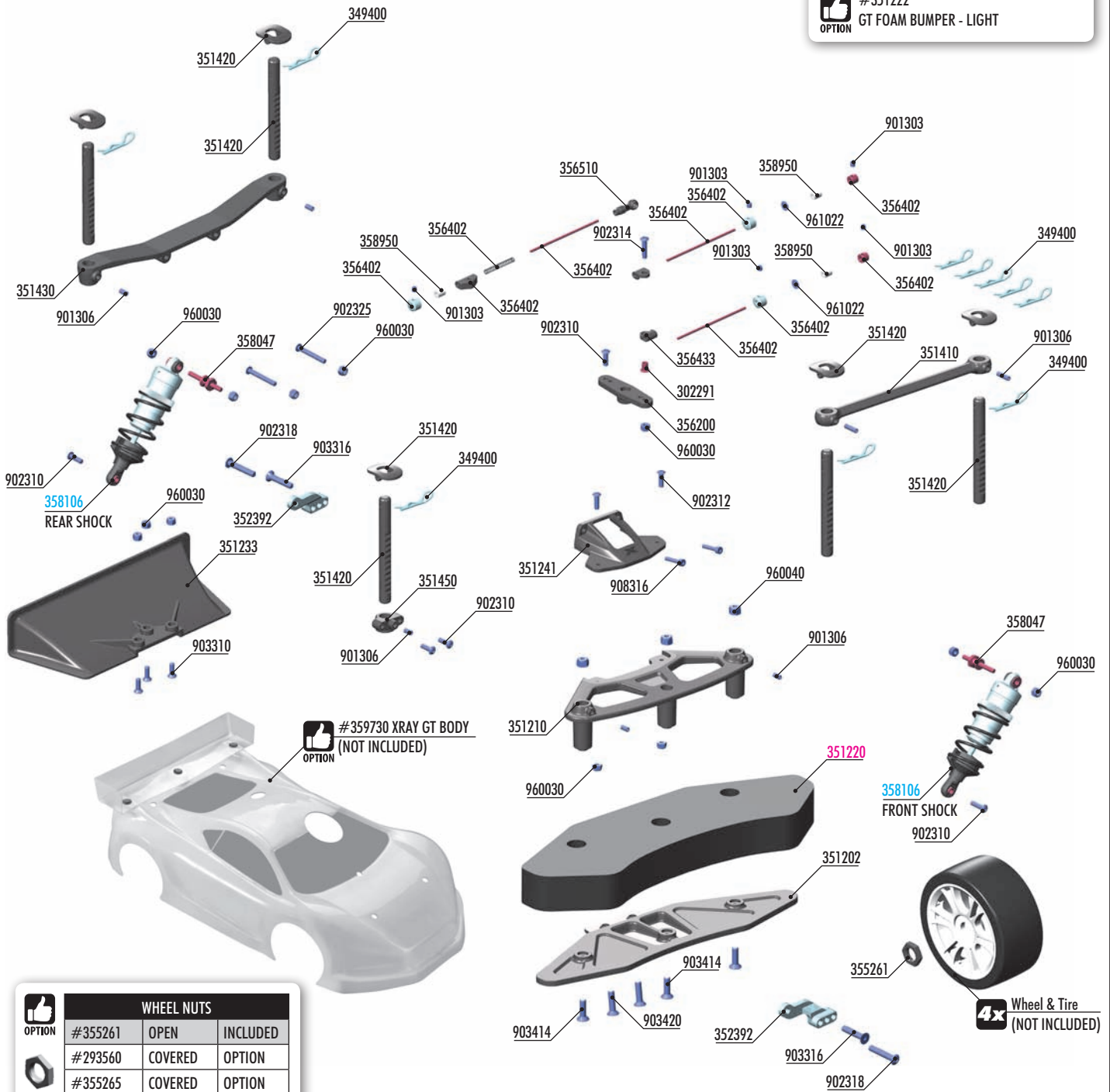

# 12. FINAL ASSEMBLY

 #351222  
OPTION GT FOAM BUMPER - LIGHT



 #359730 XRAY GT BODY  
OPTION (NOT INCLUDED)

WHEEL NUTS		
	#355261	OPEN INCLUDED
	#293560	COVERED OPTION
	#355265	COVERED OPTION

BAG

12

- |        |   |        |                                      |
|--------|---|--------|--------------------------------------|
| 302291 | STEEL STEERING BUSHING (2+2)                        | 901303 | HEX SCREW SB M3x3 (10)               |
| 349400 | BODY CLIP (10)                                      | 901306 | HEX SCREW SB M3x6 (10)               |
| 351202 | COMPOSITE FRONT BUMPER - NARROW                     | 902310 | HEX SCREW SH M3x10 (10)              |
| 351210 | GT COMPOSITE FRONT UPPER BUMPER                     | 902312 | HEX SCREW SH M3x12 (10)              |
| 351233 | GT COMPOSITE DIFFUSOR                               | 902314 | HEX SCREW SH M3x14 (10)              |
| 351241 | COMPOSITE FRONT UPPER BUMPER BRACE WITH AIR COOLING | 902316 | HEX SCREW SH M3x16 (10)              |
| 351410 | GT COMPOSITE FRONT HOLDER FOR BODY POSTS            | 902318 | HEX SCREW SH M3x18 (10)              |
| 351420 | GT COMPOSITE BODY POSTS (2)                         | 902325 | HEX SCREW SH M3x25 (10)              |
| 351430 | GT COMPOSITE REAR HOLDER FOR BODY POSTS             | 903310 | HEX SCREW SFH M3x10 (10)             |
| 351450 | GT COMPOSITE CENTER BODY POST HOLDER                | 903414 | HEX SCREW SFH M4x14 (10)             |
| 352392 | GT ALU SHOCK PLATE - SWISS 7075 T6 (L + R)          | 903420 | HEX SCREW SFH M4x20 (10)             |
| 355261 | WHEEL NUT - RIBBED - HARD COATED (2)                | 908316 | HEX SCREW SOCKET HEAD CAP M3x16 (10) |
| 356200 | BRAKE/THROTTLE ARMS & SERVO ARMS - SET              | 960030 | NUT M3 (10)                          |
| 356402 | XB8 BRAKE/THROTTLE SYSTEM - SET                     | 960040 | NUT M4 (10)                          |
| 356433 | GT COMPOSITE BRAKE WIRE HOLDER (2)                  | 961022 | WASHER S 2.2 (10)                    |
| 356510 | CLOSED BALL JOINT 3.9 (4)                           |        |                                      |
| 358047 | STEEL SCREW SHOCK PIVOT BALL WITH HEX (2)           | 358106 | GTX8 SHOCK ABSORBERS V2 (2)          |
| 358950 | SILICONE TUBING 1M (2.4 x 5.5MM)                    | 351220 | GT FOAM BUMPER                       |

# 12. FINAL ASSEMBLY

**902310**  
SH M3x10

**902318**  
SH M3x18

**903316**  
SFH M3x16

**960030**  
N M3

**INITIAL SETTING**

**ALU SHOCK PLATE**

**RL-FR** (rear left or front right)

**RR-FL** (rear right or front left)

**INITIAL SETTING**

**SET-UP BOOK**  
SHOCK ABSORBERS

**902310**  
SH M3x10

**902318**  
SH M3x18

**903316**  
SFH M3x16

**960030**  
N M3

**INITIAL SETTING**

**ALU SHOCK PLATE**

**RL-FR** (rear left or front right)

**RR-FL** (rear right or front left)

**INITIAL SETTING**

**901303**  
SB M3x3

**902314**  
SH M3x14

**960030**  
N M3

**OPTION READY**

CLAMP ALU SERVO HORNS		
#293444	23T	OPTION
#293445	24T	OPTION
#293446	25T	OPTION
#293447	23T	OPTION
#293448	24T	OPTION
#293449	25T	OPTION

**OPTION READY**

ALU SERVO HORNS		
#293504	23T	OPTION
#293505	24T	OPTION
#293506	25T	OPTION
#293507	23T	OPTION
#293508	24T	OPTION
#293509	25T	OPTION



# 12. FINAL ASSEMBLY



901306  
SB M3x6



902310  
SH M3x10

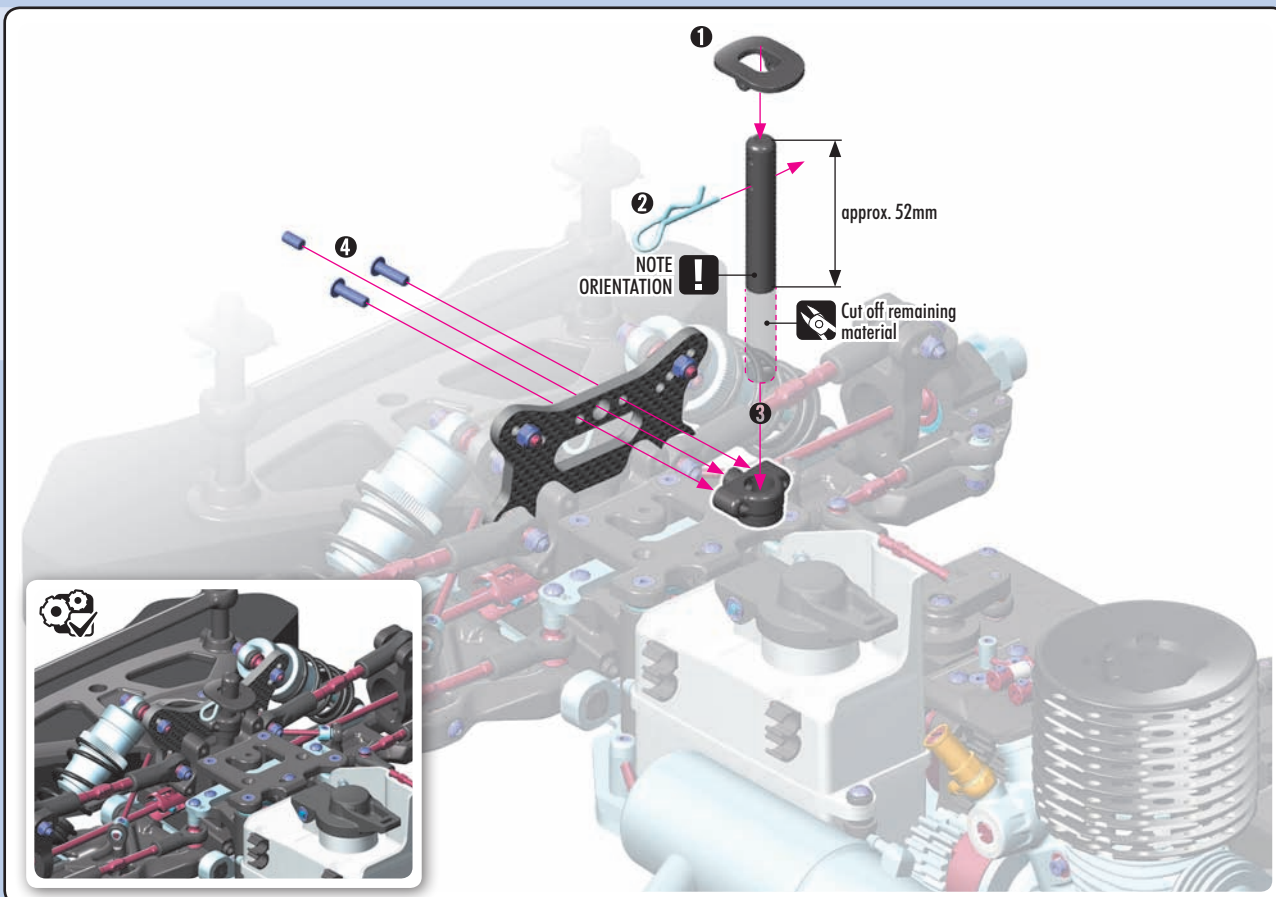

901306  
SB M3x6



902325  
SH M3x25



960030  
N M3

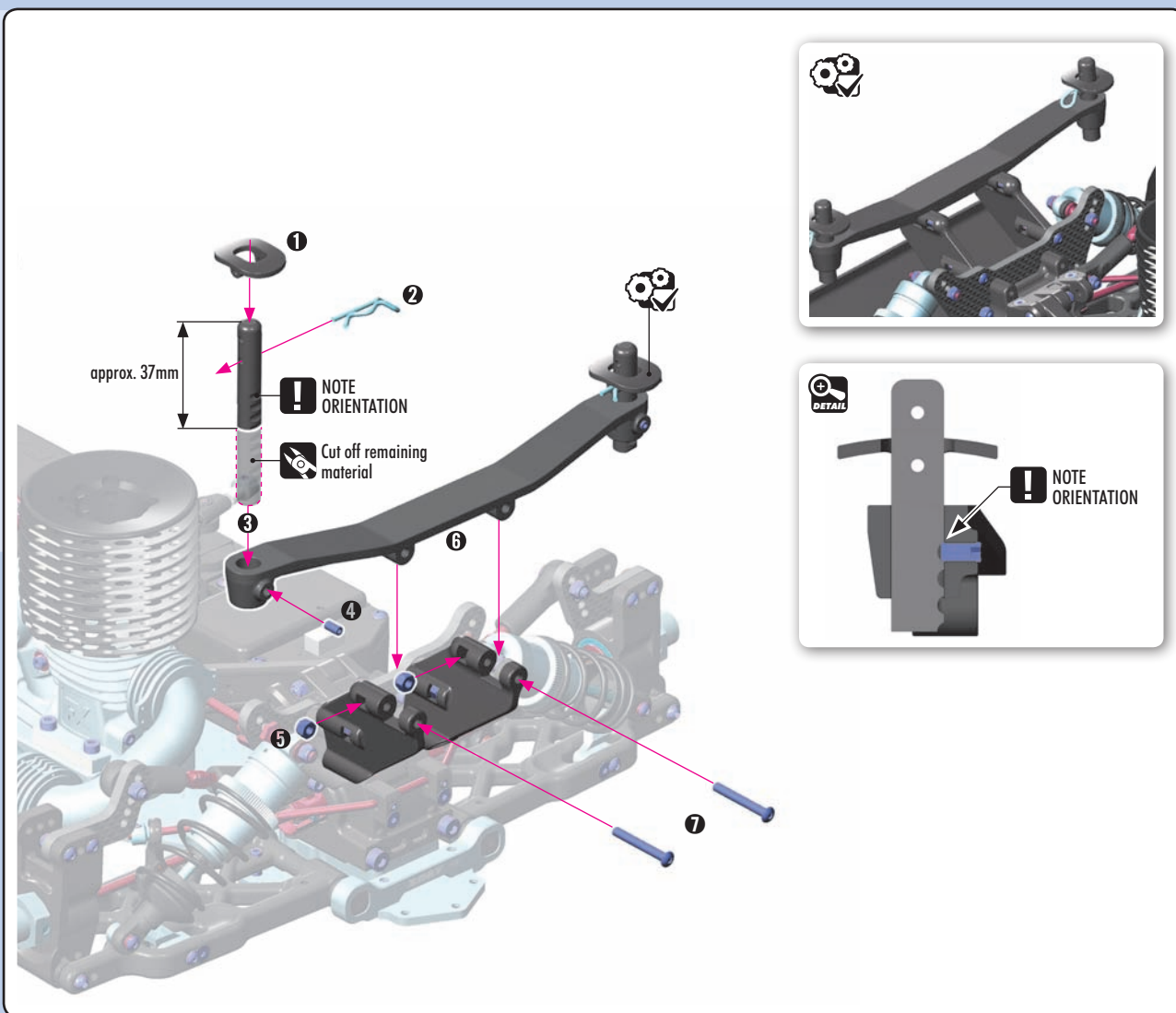

## 12. FINAL ASSEMBLY

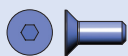

903310  
SFH M3x10



960030  
N M3

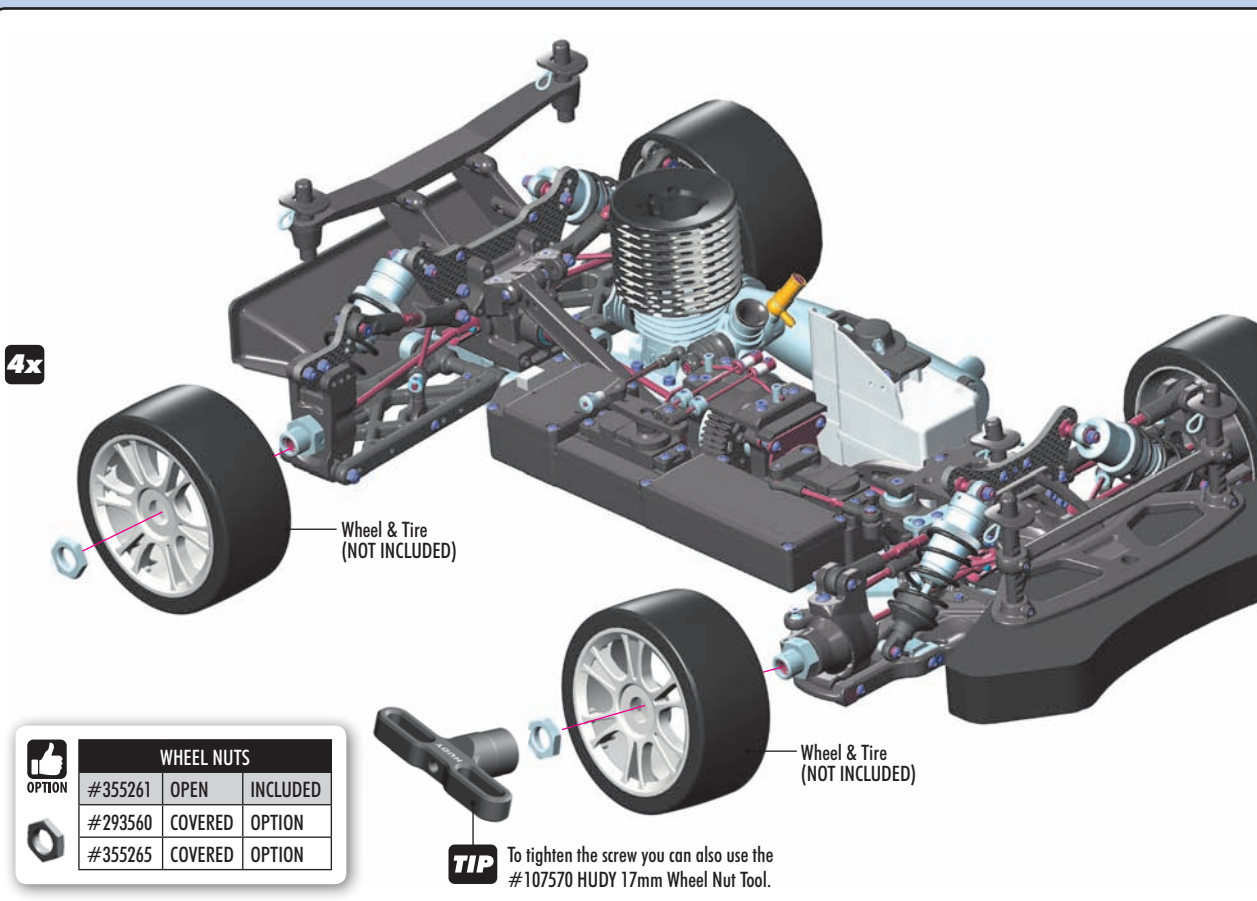
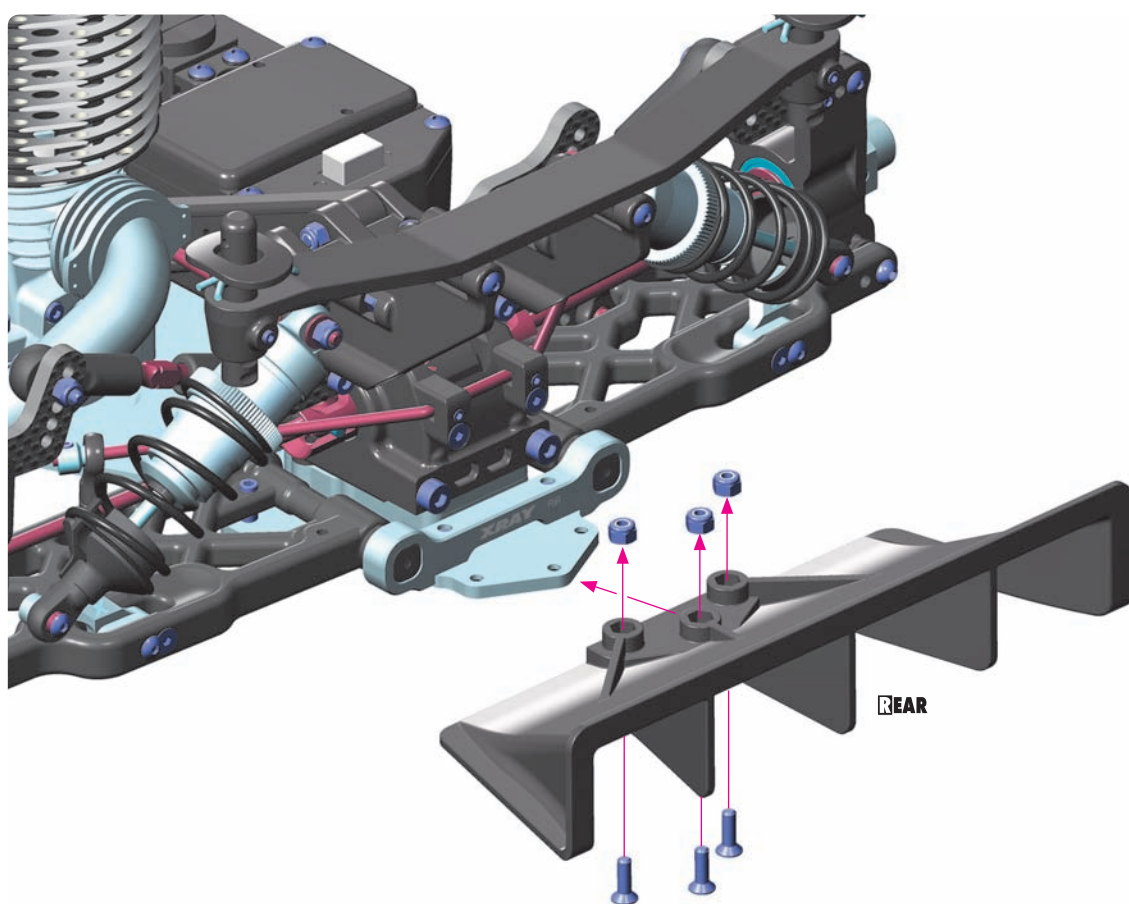

## 12. FINAL ASSEMBLY

Cut the silicone tube depending on engine and muffler. Use the plastic clips to hold the tubes together.

SILICONE TUBE MARKED AS  
BLUE = FROM FUEL TANK TO CARBURETOR

SILICONE TUBE MARKED AS  
RED = FROM MUFFLER TO FUEL TANK (TOP)

**!** Keep fuel line away from clutchbell and flywheel.

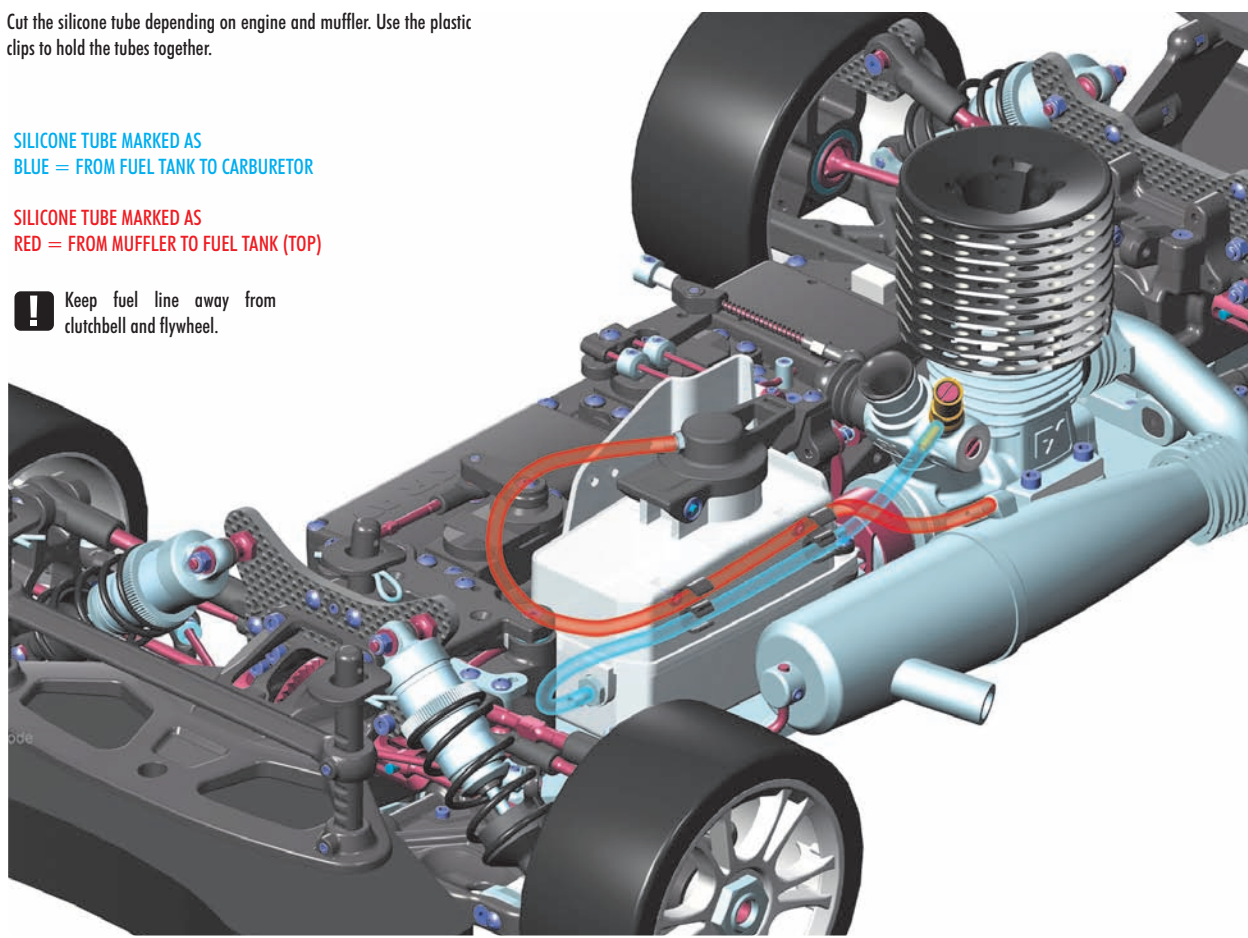

**!** #359730 GTX BODY (NOT INCLUDED)  
OPTION

- 1 Before cutting and making holes on the body, put the unpainted body on the chassis to confirm the mounting position and location for holes and cutouts.
- 2 Before painting, wash the inside of the body with mild detergent, and then rinse and dry thoroughly.
- 3 Mask all windows.
- 4 Apply paint masks as appropriate.
- 5 Paint the body using paints formulated for polycarbonate bodies.
- 6 When the paint is dry, remove the masking.
- 7 Carefully cut out the body using appropriate scissors or cutting tools.
- 8 When you have finished cutting, peel off the external protective films.



**TIP** To reinforce the body or to fix broken body use #106280 HUDY BODY FIX.

WING SHIMS			
<b>!</b> OPTION	#353565	COMPOSITE	INCLUDED
	#293561	ALU	OPTION
	#293561-0	ALU	OPTION
	#353561	ALU	OPTION

**TIP** Use Body Reamer (HUDY #107602) for all holes.

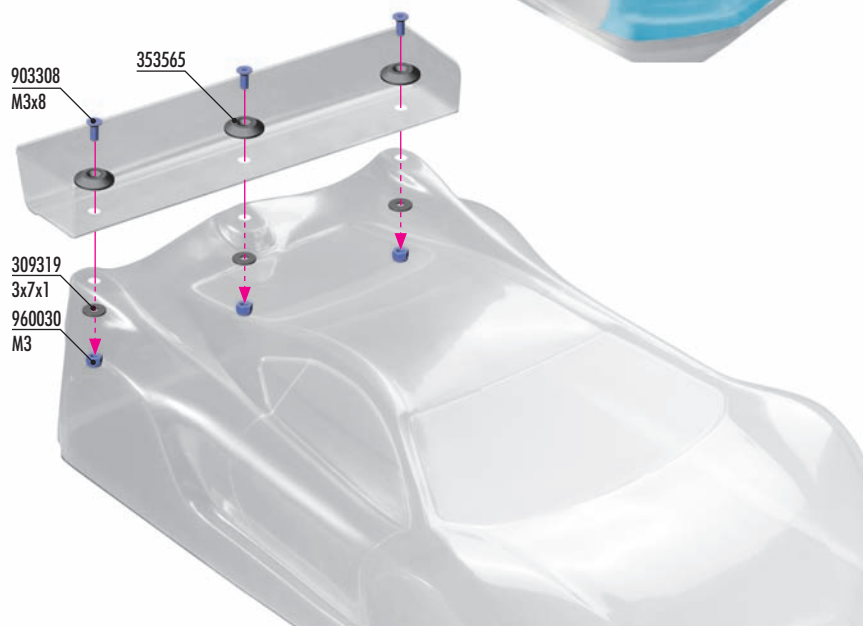
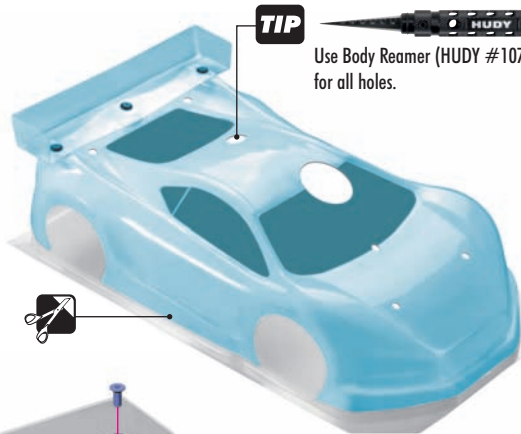

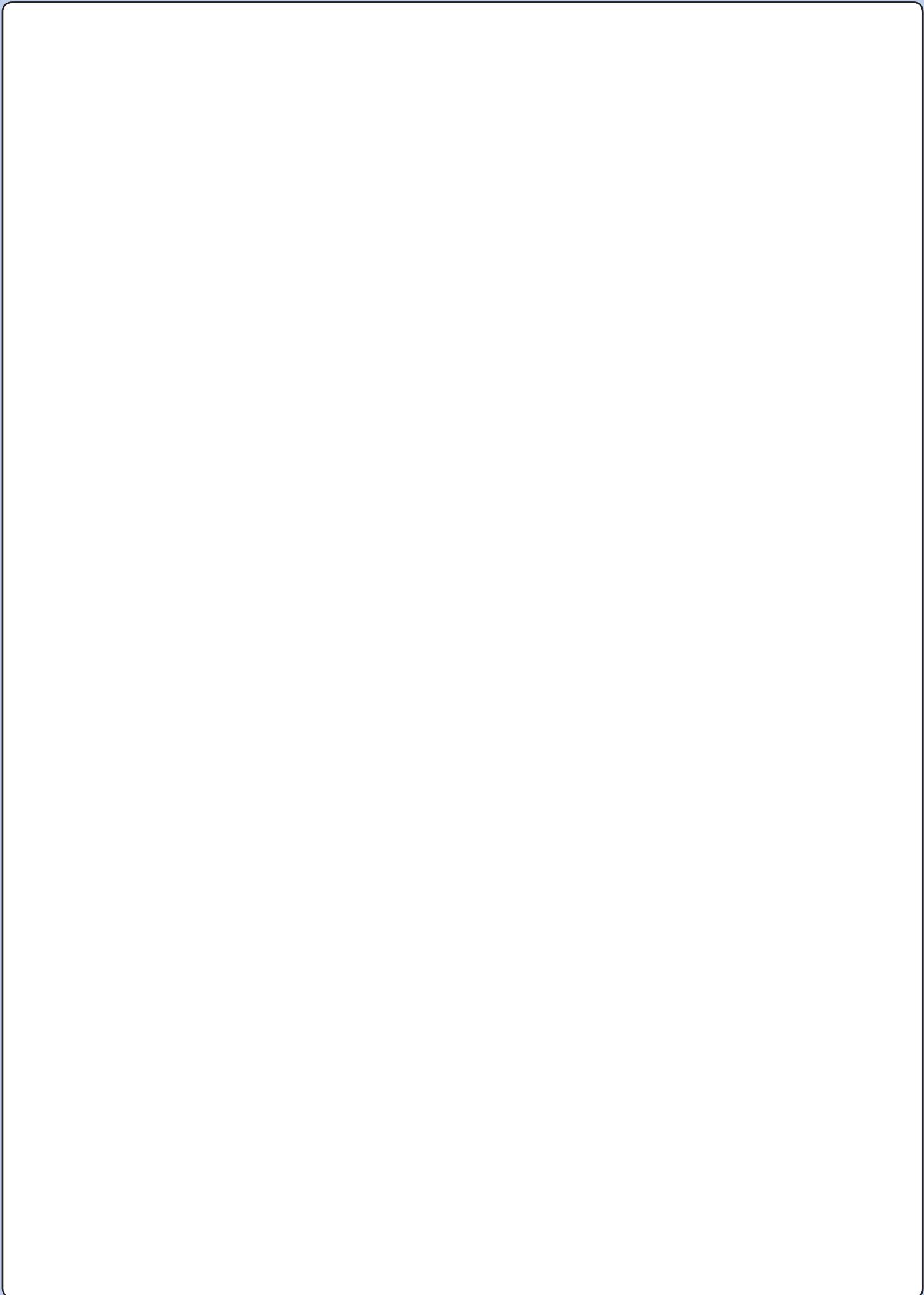

# MAINTENANCE

## ENGINE OPERATION

### PREPARING TO OPERATE THE ENGINE

- Never modify the engine or muffler.
- Confirm the position of needle and idling before running. Be sure to run a new engine smoothly.
- Make sure the air filter is clean and oiled.
- Never run your engine without an air filter. Your engine can be seriously damaged if dirt and debris get inside the engine.

### STARTING AND RUNNING THE ENGINE

Be sure to observe the following starting process. Failure to do so may cause the model car to start suddenly, which may lead to damage or unexpected accidents.

1. Make sure the transmitter and receiver batteries are fully charged.
2. Make sure that your transmitter and receiver are both on the same frequency. If you have a transmitter with multiple model memory, make sure you have selected the proper profile for your car.
3. Put the car on the starter box and keep the tires from touching the ground.
4. Turn on the transmitter.
5. Turn on the receiver in the car.
6. Make sure the steering servo and engine servos work normally and adjust them correctly.
7. Put fuel in the fuel tank, and close the cap securely.
8. Apply the glow igniter to the engine glowplug.
9. Push the model car onto the starter box to start the engine. (If the engine is new, follow the instruction manual and be sure to break in the new engine properly).
10. When the engine has started, remove the glow igniter.
11. Follow your engine break-in procedure and tune the engine as appropriate.

### STOPPING THE ENGINE

Before you stop the engine, try to make sure the engine is at idle first. There are several ways to stop the engine:

- Use a rag to cover the exhaust tip. Be careful! The exhaust is extremely hot so use a thick rag and gloves.
- Pinch the fuel tubing to stop the flow of fuel to the carb. Be careful, this can make the motor run lean which can damage the motor.
- Put your hand over the air filter, or squeeze the air filter element to block the airflow.
- Press an object (such as a screwdriver handle or shoe) against the rotating flywheel to stop its rotation. Be very careful, and do not stick your hand or fingers near the rotating flywheel.

### FINISHING OPERATIONS

1. Stop the engine.
2. Turn off the receiver in the car
3. Turn off the transmitter.

### MAINTENANCE AFTER RUNNING

Take proper care of your car after running to keep it performing well, and take notice of any damage and wear.

1. Do not leave fuel in the tank.
2. Go outside to drain any residual fuel from the exhaust pipe.
3. Clean the car and remove all sand, mud, and other debris.
4. Use after-run oil in your engine after you have finished running for the day.

## SHOCK MAINTENANCE

The most important maintenance task for keeping consistent shock performance is refilling and bleeding them correctly. If built correctly, it will not be necessary to re-build them often. Replacing warped/hard rubber bladders and o-rings, scarred piston rods, or shaved/split/loose composite upper and lower ball joints are also important.

- For club racing, it is recommended to check the shocks for air inside before each race and only re-fill and bleed them if necessary. Before each race day, make sure you take the spring off of each shock, hold it up to your ear, and quickly compress the shock rod fully into the body while listening for any air making a "whistling" or "squishy" sound as it passes through the piston holes. If you hear any air, refill and bleed your shocks. For high-competition racing, it is recommended that the shocks be re-filled and bled before a large event.
- If building or pairing new shocks, always make sure they are the same length using a shock length measuring tool and adjust the lower ball joints as needed.
- If installing new rubber bladders, carefully trim the thin excess rubber from the edges of their lips. Curved body scissors work the best.
- Regularly inspect the amount of dirt on the felt protector in the shocks (if present) and regularly replace with a new one.
- During regular shock operation, oil naturally gets on the shock shaft and drop-by-drop slightly gets out of the shock body. Shocks should be inspected regularly after each race, and oil replaced as required.

## BEARING MAINTENANCE

Ball-bearings in an off-road car or truggy must be properly maintained for smooth operation and long lifespan.

Typically, the ball-bearings included in new cars are greased for highest lifespan and as such the drivetrain may not seem to be as free as with lightly-oiled ball-bearings. However, when the car is run the ball-bearings will become more free and the drivetrain will become very efficient.

There are several types of bearings discussed here: bearings which already come greased from the factory, bearings which must be lubricated using the HUDY Bearing Grease, and then there are also bearings in the steering system which need to be lubricated with HUDY Bearing Oil.

The following procedures are recommended to clean all of the bearings in your off-road car or truggy. For high-competition racing, we recommended doing this every 3-4 weeks, or before a major race.

1. Remove the seals on both sides of the bearing (if present). If the seals bend a little and you can see a kink, carefully flatten the kink out by hand.
2. Spray the seals with motor cleaner and blow dry with compressed air.
3. Spray the bearing on both sides with motor cleaner.
4. Spin the bearing while it is still wet to dislodge any particles with the cleaner.
5. Spray the bearing on both sides again.
6. Blow both sides of the bearing dry with compressed air to make sure particles come out.
7. Hold the inner part of the bearing with my left thumb/forefinger and spin it to make sure it spins free without any abnormal vibrations or sounds.
8. Place one drop of bearing oil into each side of the bearing.
9. Replace both seals at the same time by lining them up on each side of the bearing and lightly pressing them in all the way around the bearings circumference with your thumb and forefinger. Do not press too hard or use any type of tool, such as a wrench tip, to push the blue seals in as they will push in too far, bend and cause drag.

If you spin test the bearing after you have re-oiled and sealed it, it will not spin freely for an extended period of time. The lightest of oils may allow it to spin for 1-2 seconds. This is normal and once you have mounted the bearings in the car again, the drive train will spin freely.

Make sure you use a motor cleaner that does not leave a residue after it dries as this may cause drag and wear in the bearings.

HUDY #106230

### CLUTCH BEARINGS

To prolong the lifespan of the clutch bearings, they must be regularly cleaned and lubricated (preferably after each run) using a high-quality grease such as HUDY Bearing Grease. However, after some time the clutch bearings must be replaced with new ones.

### RECOMMENDED PRODUCTS

- Use HUDY Bearing Grease to regularly lubricate grease-bearing ball-bearings.
- Use HUDY Bearing Oil to lubricate the bearings of the steering system.
- Use HUDY Bearing Grease to regularly lubricate the clutch bearings.

HUDY  
#106213



HUDY  
#106220



HUDY  
#106222



HUDY  
#106221



## SUSPENSION & DRIVETRAIN MAINTENANCE

- Check suspension for free movement during building and operation, and especially after running and if you have crashed the car. If the suspension does not move freely, use the appropriate HUDY Arm Reamer to clean and resize the holes of the suspension arms.
- Regularly check the drive shaft pins (both side and center) and if they show any wear must be immediately replaced by new pins. If the car is run with worn pins, excessive wear on the diff outdrives will result. The 106000 HUDY Drive Pin Replacement Tool (for 3mm Pins) is a compact, rugged multi-use tool set for replacing 3mm drive pins in drive shafts. Use the HUDY replacement drive shaft pins 3x14 (#106050).
- Regularly inspect and replace the connecting pins which connect the center drive shafts with the pinion gear, and also the pins that connect the wheel drive shafts with wheel axles. Use HUDY Graphite Grease to lubricate the drive shaft connecting joints and the diff gears.
- Pivot balls and ball-joints will naturally wear for some time and will generate play. If there is too much play the pivot balls and ball joints need to be replaced.
- If the car is run in wet conditions, apply WD-40® on all drivetrain parts before the run. After the run, clean and dry the parts again.

### HUDY SPRING STEEL™

The HUDY Spring Steel™ used in the car is the strongest and most durable steel material on the RC market. While items made from HUDY Spring Steel™ are still subject to wear, the lifespan is considerably longer than any other material. As parts made from HUDY Spring Steel™ wear, the brown color will after some time "go down" but it will not affect the strength of the material. The brown color is only a surface treatment and if the brown color will wear the durability of the part will be still strong.



# THROTTLE LINKAGE ADJUSTMENT

## NEUTRAL (IDLE)

ADJUST INDIVIDUAL LINKAGES SEPARATELY TO AVOID INTERFERING WITH THE OPERATION OF THE OTHERS

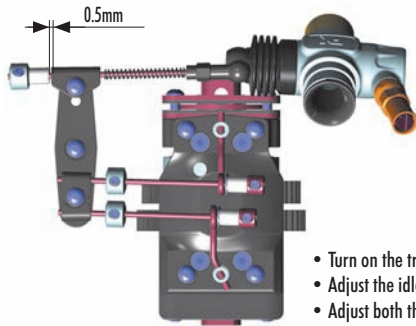

- Turn on the transmitter and receiver and set the engine control servo trim to the neutral position.
- Adjust the idle adjustment screw on the carburetor to open approx. 1mm.
- Adjust both the throttle linkage and brake linkages accordingly.
- DO NOT adjust the linkage with the engine running.

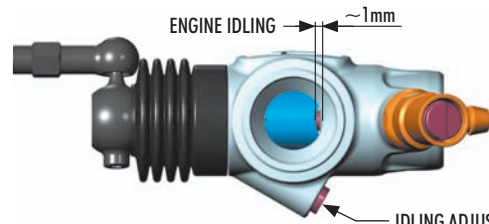

**IDLING ADJUSTMENT SCREW.**  
Use to adjust the idle setting of the carburetor. Do not allow carburetor to close to less than 1mm.

## FULL THROTTLE

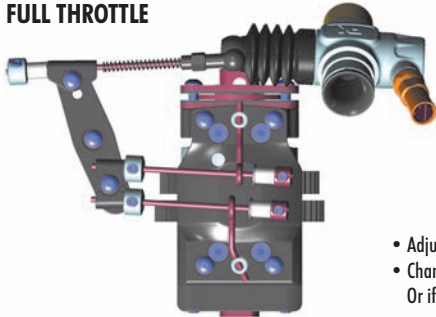

- Adjust the servo-horn mounting position for the carburetor to open fully.
- Change the pivot mounting position on the servo horn in case the carburetor is not opening fully or if it is opening excessively. Or if available on the transmitter, adjust the throttle high end point.

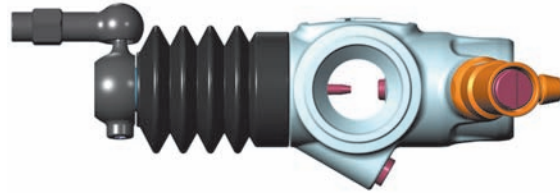

## BRAKE

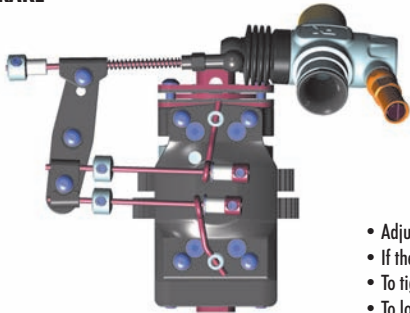

- Adjust the adjustable collars so the brakes work smoothly.
- If the brakes apply too much or not enough, adjust the adjustable collars accordingly. Or if available on the transmitter, adjust the brake endpoint.
- To tighten brakes, turn collar to thread brake rod INTO pivot.
- To loosen brakes, turn collar to thread brake rod OUT of pivot.

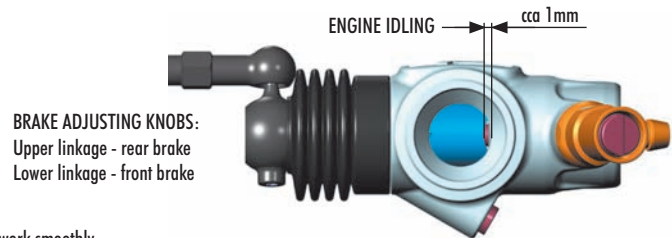

**BRAKE ADJUSTING KNOBS:**  
Upper linkage - rear brake  
Lower linkage - front brake

## TROUBLESHOOTING GUIDE

PROBLEM	CAUSE	SOLUTION
ENGINE DOES NOT START	<ul style="list-style-type: none"> <li>• Fuel tank is empty or carburetor is not primed</li> <li>• Bad glowplug or dead glowdriver battery</li> <li>• Fuel lines, fuel filter, air cleaner, or muffler is clogged</li> <li>• Engine is flooded due to over-priming</li> <li>• Carburetor is not adjusted properly</li> <li>• Throttle servo linkage not adjusted properly</li> </ul>	<ul style="list-style-type: none"> <li>• Fill fuel tank with fuel and prime</li> <li>• Replace glowplug or recharge/replace glowdriver battery</li> <li>• Clean or replace clogged part(s)</li> <li>• Remove glowplug, turn car over to discharge fuel from cylinder. Test glowplug and replace if defective</li> <li>• Set idle and main/slow needle adjusting screw to standard starting position</li> <li>• Move throttle servo to neutral position and re-adjust linkage(s)</li> </ul>
ENGINE STARTS BUT THEN STALLS	<ul style="list-style-type: none"> <li>• Fuel tank is empty</li> <li>• Fuel lines, fuel filter, air cleaner, or muffler is clogged</li> <li>• Carburetor is not adjusted properly</li> <li>• Engine has overheated</li> </ul>	<ul style="list-style-type: none"> <li>• Fill fuel tank with fuel</li> <li>• Clean or replace clogged part(s)</li> <li>• Re-adjust idle and main/slow needle adjusting screw</li> <li>• Allow engine to thoroughly cool down and open main needle adjusting screw 30° turn richer (CCW)</li> </ul>
BAD REACTION AND RESPONSE FROM ENGINE	<ul style="list-style-type: none"> <li>• Carburetor is not adjusted properly</li> <li>• Fuel lines, fuel filter, air cleaner, or muffler is clogged</li> <li>• Low fuel pressure from muffler</li> </ul>	<ul style="list-style-type: none"> <li>• Re-adjust main/slow needle adjusting screw</li> <li>• Clean or replace clogged part(s)</li> <li>• Properly install pressure line between muffler and fuel tank</li> </ul>
CAR IS HARD TO CONTROL	<ul style="list-style-type: none"> <li>• Weak transmitter and/or receiver batteries</li> <li>• Low reception from radio antennas</li> <li>• Servo linkages not adjusted properly</li> </ul>	<ul style="list-style-type: none"> <li>• Recharge or replace batteries</li> <li>• Fully extend transmitter and receiver antennas</li> <li>• Move servo to neutral then re-adjust linkage(s)</li> </ul>
STEERING DOES NOT WORK PROPERLY	<ul style="list-style-type: none"> <li>• Weak transmitter and/or receiver batteries</li> <li>• Bent linkages or driveshafts</li> <li>• Loose steering components</li> <li>• Drivetrain damage</li> </ul>	<ul style="list-style-type: none"> <li>• Recharge or replace batteries</li> <li>• Check tightness of steering components and tighten if necessary</li> <li>• Replace damaged parts</li> </ul>
HANDLING PROBLEMS	<ul style="list-style-type: none"> <li>• Shocks are not working properly</li> <li>• Suspension is binding</li> <li>• Improper tires</li> </ul>	<ul style="list-style-type: none"> <li>• Rebuild the shocks and replace worn or broken parts</li> <li>• Make sure suspension moves freely. Replace worn or broken parts</li> <li>• Use different tires</li> </ul>
STEERING FEELS SLUGGISH OR VAGUE	<ul style="list-style-type: none"> <li>• Suspension is binding</li> <li>• Damaged steering servo</li> </ul>	<ul style="list-style-type: none"> <li>• Make sure suspension moves freely, and replace worn or broken parts</li> <li>• Check the steering servo for damage and wear, and replace/repair if necessary</li> </ul>
THE CAR DOES NOT DRIVE STRAIGHT	<ul style="list-style-type: none"> <li>• Suspension is binding</li> <li>• Steering trim is off-center</li> <li>• Wheels are loose</li> <li>• Damaged steering servo</li> </ul>	<ul style="list-style-type: none"> <li>• Make sure suspension moves freely, and replace worn or broken parts</li> <li>• Adjust steering trim until car drives straight</li> <li>• Check the make sure the wheel nuts are properly tightened</li> <li>• Check the steering servo for damage and wear, and replace/repair if necessary</li> </ul>

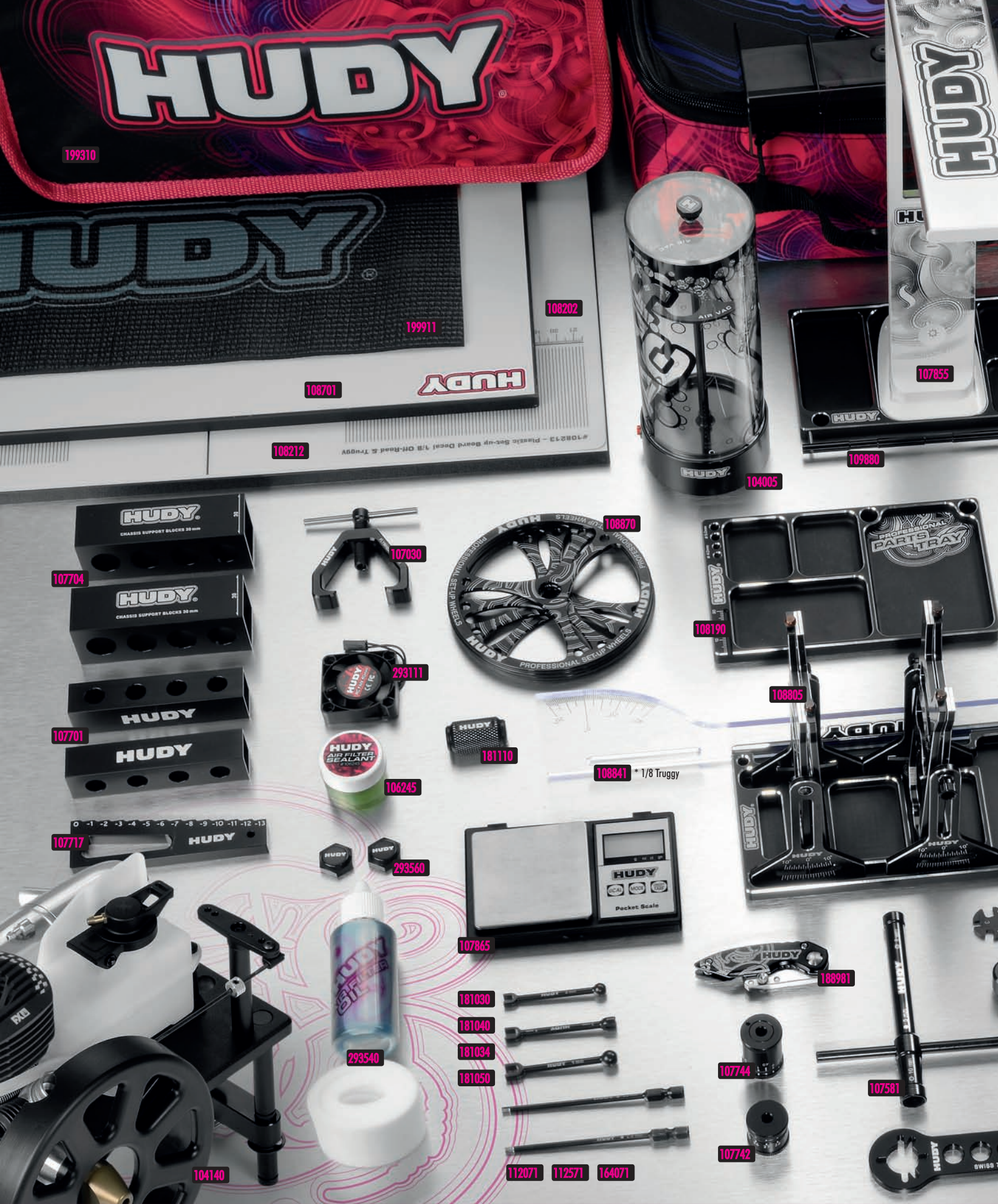

- #104005 HUDY Air Vac - Vacuum Pump - 1/8 Off-Road
- #104140 HUDY Engine Break-In Bench
- #104500 HUDY Star-Box 1/8 Off-Road
- #105500 HUDY Universal Tire Balancing Station
- #105510 Wheel Adapter for 1/8 Off-Road Cars, Truggy & Rally Game
- #106000 HUDY Drive Pin Replacement Tool (for 3mm Pins)
- #106200 HUDY Magic Cleaning Gum
- #106245 HUDY Air Filter Sealant
- #107030 HUDY Flywheel Puller
- #107090 HUDY Bearing Check Tool
- #107570 HUDY 17mm Off-Road Wheel Nut Tool
- #107581 HUDY Cross Wrench Glowplug # 8mm / Clutchnut # 10mm
- #107602 Limited Edition - Reamer for Body 0-18mm + Cover - Large

- #107612 Limited Edition - Exhaust Spring / Caster Clip Remover
- #107644 Limited Edition - Arm Reamer # 4.0mm
- #107701 Chassis Droop Gauge Support Blocks 20mm for 1/8 - LW(2)
- #107704 Chassis Droop Gauge Support Blocks 30mm 1/8 Off-Road - LW (2)
- #107717 Chassis Droop Gauge 0 to -13 mm for 1/8 Off-Road
- #107742 HUDY Adjustable Ride Height Gauge 20-30mm
- #107744 HUDY Adjustable Ride Height Gauge 30-45mm
- #107762 HUDY Adjustable Camber Gauge 110mm
- #107780 HUDY Adjustable Droop Gauge 80-140mm
- #107783 HUDY Droop Gauge 70-140mm
- #107855 HUDY Pit LED
- #107865 HUDY Ultimate Digital Pocket Scale 300g/0.01g
- #108170 HUDY Off-Road & Truggy Car Stand

- #108190 HUDY Alu Tray for Parts
- #108202 Flat Set-Up Board for 1/8 Off-Road & Truggy
- #108212 Plastic Set-up Board Decal for 1/8 Off-Road & Truggy
- #108701 Flat Set-Up Board for 1/8 Off-Road & GT - Lightweight
- #108805 Universal Exclusive Set-up System for 1/8 Off-Road Cars
- #108841 Upside Measure Plate for 1/8 Truggy
- #108860 Alu Nut for 1/8 Off-Road System (4)
- #108870 Alu Set-up Wheel for 1/8 Off-Road Cars - V2 (4)
- #109802 HUDY Alu Tray for 1/8 Off-Road Diff & Shocks
- #109841 HUDY Alu Tray for 1/8 Off-Road Diff Assembly
- #109860 HUDY Alu Tray for Set-Up System
- #109880 HUDY Alu Tray for Accessories & Pit LED
- #11545 Limited Edition - Allen Wrench # 1.5mm

EXCLUSIVE PROFESSIONAL

# HUDY



- #112045 Limited Edition - Allen Wrench # 2.0mm
- #112071 Power Tool Tip Allen 2.0 x 90 mm
- #112545 Limited Edition - Allen Wrench # 2.5mm
- #112571 Power Tool Tip Allen 2.5 x 90 mm
- #113045 Limited Edition - Allen Wrench # 3.0mm
- #132045 Limited Edition - Allen Wrench + Ball Repl. Tip # 2.0mm
- #132545 Limited Edition - Allen Wrench + Ball Repl. Tip # 2.5mm
- #154060 Long Slotted Screwdriver 4.0 mm - for Engine Adjust. - SPC - V2
- #164045 Limited Edition - Phillips Screwdriver # 4.0mm
- #164071 Power Tool Tip Phillips 4.0 x 90 mm
- #170050 Socket Driver 5.0 mm
- #175535 Limited Edition - Socket Driver # 5.5mm
- #181030 HUDY Spring Steel Turnbuckle Wrench 3 mm

- #181034 HUDY Spring Steel Turnbuckle Wrench 3 & 4mm
- #181040 HUDY Spring Steel Turnbuckle Wrench 4 mm
- #181050 HUDY Spring Steel Turnbuckle Wrench 5 mm
- #181090 HUDY Special Tool For Turnbuckles & Nuts
- #181110 HUDY Ball Joint Wrench
- #182015 HUDY 1/8 Off-Road Flywheel/Wheel Nut Multi-Tool
- #183011 HUDY Professional Multi Tool
- #188981 HUDY Pocket Hobby Knife
- #188990 HUDY Professional Body Scissors
- #199060 HUDY Alu Tool Stand
- #199184 HUDY Car Bag - 1/8 & 1/10 Off-Road
- #199270 HUDY LiPo Safety Bag
- #199310 HUDY Pit Bag - Compact

- #199911 HUDY Pit Mat Roll 750x1200mm with Printing
- #293111 HUDY Brushless RC Fan 40mm
- #293540 Air Filter Foam & Oil (10) - XRAY XB8 Low Profile Style
- #293560 HUDY Alu Wheel Nut with Cover - Ribbed (2)

For more information about tools, set-up equipment and accessories suitable for your car please visit:

[www.hudy.net](http://www.hudy.net)



**[www.teamxray.com](http://www.teamxray.com)**

**XRAY EUROPE**

XRAY, K VÝSTAVISKU 6992, 91101 TRENCIN, SLOVAKIA, EUROPE  
PHONE: +421-32-740 11 00, FAX: +421-32-740 11 09, [info@teamxray.com](mailto:info@teamxray.com)

**XRAY USA**

RC AMERICA, 2030 Century Center Blvd #15, Irving, TX 75062, USA  
PHONE: 214-744-2400, FAX: 214-744-2401, [xray@rcamerica.com](mailto:xray@rcamerica.com)



/TeamXray



/TeamXray



/TeamXray



/XrayRacing



/+TeamXrayRC



/XrayRacing