

DRIVER _____
 TRACK _____
 RACE _____ DATE _____
 TEMP _____ BEST LAP _____ BEST RESULT _____ QUALIFYING POS. _____ FINAL POS. _____

TRACK SIZE TIGHT MEDIUM OPEN
 SURFACE DUSTY BLUE GROOVE LOW GRIP MEDIUM GRIP HIGH GRIP
 CONDITION SMOOTH BUMPY 50/50 CLAY GROOVE WITH DUST EGY

ENGINE _____	CLUTCH _____	FRONT DIFF OIL _____	OIL QUANTITY (gr) _____	DIFF GEAR _____
PLUG _____	CLUTCH SHOES _____	CENTER DIFF OIL _____	OIL QUANTITY (gr) _____	DIFF PINION _____
PIPE _____	CLUTCH SPRINGS _____	REAR DIFF OIL _____	OIL QUANTITY (gr) _____	SPUR GEAR _____
FUEL _____	RUNTIME _____			CLUTCH BELL _____

SHOCKS

	FRONT	REAR
OIL _____		
PISTON _____		
SPRING _____		
LENGTH _____		
VISIBLE SHAFT LENGTH _____		
REBOUND _____		
FRONT SHOCK END <input type="checkbox"/> LONG <input type="checkbox"/> SHORT	SHOCKS <input type="checkbox"/> EMULSION TYPE <input type="checkbox"/> BLADDER	
NOTES		

FRONT END

SHOCK TOWER ALUMINIUM CARBON

HEX WIDTH 4 mm 5 mm 6 mm

KNUCKLE PLATE 1 LONG 2 SHORT

FRONT ARM POSITION FRONT MIDDLE REAR

ARM INSERT NO PLASTIC CARBON

KNUCKLE POSITION UP MIDDLE DOWN

KPI OPTION KPI 0 (ROUND MARK) KPI 1 (LONG MARK)

C BLOCK CASTER CASTER 1 (1 MARK) CASTER 2 (2 MARKS)

SERVO SAVER YES NO

BUMP STEER ON ACKERMAN UP DOWN SHIM _____ mm

BUMP STEER ON KNUCKLE UP DOWN SHIM _____ mm

KICK UP

1 <input type="checkbox"/>	0,5 <input type="checkbox"/>	0 <input type="checkbox"/>	0,5 <input type="checkbox"/>	1 <input type="checkbox"/>
1 <input type="checkbox"/>	0,5 <input type="checkbox"/>	0 <input type="checkbox"/>	0,5 <input type="checkbox"/>	1 <input type="checkbox"/>

A PLATE B PLATE TOWER

+2mm SHIM (NO upper gearbox shim) +2

+1mm SHIM (1mm upper gearbox shim) +1

NO SHIM (2mm upper gearbox shim) 0

CHASSIS

	FRONT	REAR
CAMBER _____		
RIDE HEIGHT _____		
DOWNTRAVEL (WITH TYRES) _____		
DOWNTRAVEL (on 36mm blocks) _____		
ANTI ROLL BARS _____		
BRAKE BALANCE _____		
ENGINE MOUNT <input type="checkbox"/> FORWARD (+2mm) <input type="checkbox"/> SHORT <input type="checkbox"/> BACKWARD (-2mm) <input type="checkbox"/> LONG		
THROTTLE <input type="checkbox"/> SHORT SERVO MOUNT <input type="checkbox"/> LONG WEIGHT _____		

REAR END

SHOCK TOWER ALUMINIUM CARBON

ARM INSERT NO PLASTIC CARBON

OPTIONAL REAR HUB

REAR HUB PLASTIC ALUMINIUM

HEX WIDTH 4 mm 5 mm 6 mm

SPACER IN FRONT OF HUB _____ mm

REAR AXLE CVD UNIVERSAL 91 94

ANTI-SQUAT

1 <input type="checkbox"/>	0,5 <input type="checkbox"/>	0 <input type="checkbox"/>	0,5 <input type="checkbox"/>	1 <input type="checkbox"/>
1 <input type="checkbox"/>	0,5 <input type="checkbox"/>	0 <input type="checkbox"/>	0,5 <input type="checkbox"/>	1 <input type="checkbox"/>

C PLATE D PLATE TOWER

+2mm SHIM +2

+1mm SHIM +1

NO SHIM 0

TYRES

	FRONT	REAR
BRAND _____		
TREAD _____		
COMPOUND _____		
WHEELS _____		
INSERTS _____		
GLUED TO WHEEL <input type="checkbox"/> YES <input type="checkbox"/> NO		<input type="checkbox"/> YES <input type="checkbox"/> NO

RADIO SETTINGS

	THROTTLE	STEERING
DUAL RATE _____		
SPEED _____		
EXPO _____		
SERVO MODEL _____		
	THROTTLE	BRAKE
ELECTRIC EPA _____		

BODY & WING

BODYSHELL _____

WING BRAND _____

WING MODEL _____

WING POSITION 1 2 3 4
1 IS FRONT HOLE (WING BACK)

WING FLAPS BIG SMALL BOTH

GURNEY NO SMALL BIG

NOTES

DRIVER _____
 TRACK _____
 RACE _____ DATE _____
 NOTE _____

SETUP SHEET
 v. 1.0 - UPPER ARMS

FRONT END - UPPER ARMS

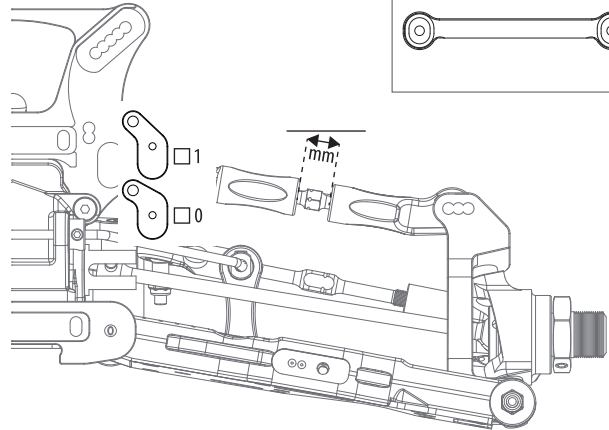
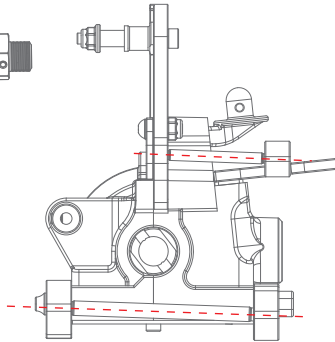
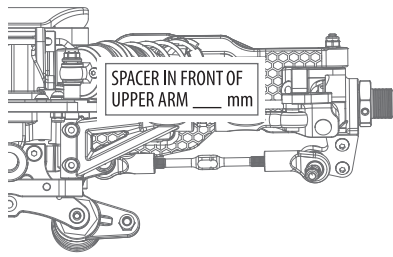

FRONT REAR UPPER BRACE

<input type="checkbox"/>	UP
<input type="checkbox"/>	MIDDLE
<input type="checkbox"/>	DOWN

REAR END - UPPER ARMS

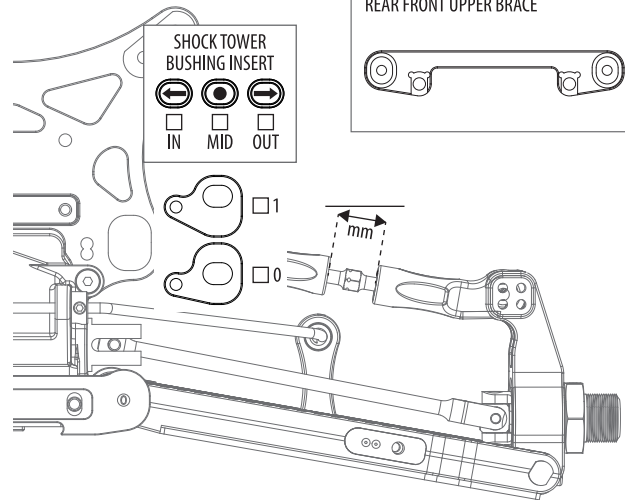
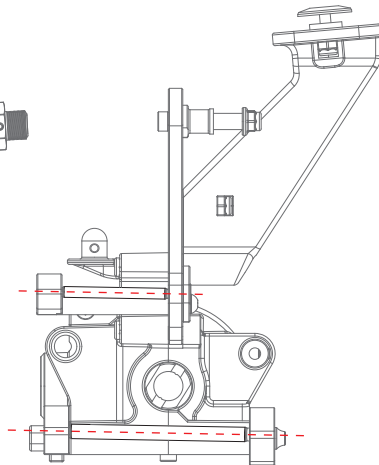
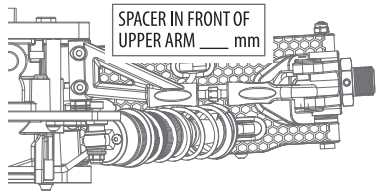

REAR FRONT UPPER BRACE

<input type="checkbox"/>	UP
<input type="checkbox"/>	MIDDLE
<input type="checkbox"/>	DOWN

SHOCK TOWER BUSHING INSERT

<input type="checkbox"/>	IN	<input type="checkbox"/>	MID	<input type="checkbox"/>	OUT
--------------------------	----	--------------------------	-----	--------------------------	-----

ADJUSTING UPPER ARMS

The upper arm angle is to be matched to the lower arm angle. There is a compromise for the upper arm, as a .5 change for the upper arm is so small.

The way to understand how to adjust the upper arm is as follows

- When you have the same inserts, in the same direction in the front and rear blocks (A-B, or C-D), you should use the 0 insert for the upper arm.
Example:
 When you run 0-0, .5 down - .5 down, or 1 up - 1 up in the A-B, or C-D blocks, those are all examples of running the same inserts and direction in both blocks. This means you should run the 0 (middle) insert for the upper arm.
- When you have a 1mm difference between the inserts in the front and rear blocks (A-B, or C-D), you need to use the 1 (end) insert for the upper arm, in the same direction as the lower arm is angled, either larger or smaller angle.
Example:
 When you run 0-1 down, 1 up - 0, or .5 up - .5 down, those are all examples of a 1mm difference and a larger angle. You would need to run the 1 insert (end) down for the upper arm, making it a larger angle to match. The opposite is true when you reduce the lower arm angle by a 1mm difference.
- When you have a .5 difference between the inserts in the front and rear blocks (A-B, or C-D), you can chose to run either the 0 insert, or the 1 insert for the upper arm, matching the direction of the angle change of the lower arm.
Example:
 When you run 0 - .5 up, .5 down - 0 or 1 down - .5 down, those are all examples of a .5mm difference and a smaller angle. You would need to run the 0 insert, or 1 insert up for the upper arm. The opposite is true when you increase the lower arm angle by a .5mm difference.

The way to understand how to adjust the upper arm related to TOE IN is as follows

- 1.5° toe in: arrow inwards
- 3.0° toe in: arrow outwards