

1/10 LUXURY NITRO TOURING CAR

XRAY NT1



INSTRUCTION MANUAL
XRAY NT1.2

BEFORE YOU START

The NT1 is a high-competition, high-quality, 1/10-scale nitro car intended for persons aged 16 years and older with previous experience building and operating RC model racing cars. This is not a toy; it is a precision racing model. This model racing car is not intended for use by beginners, inexperienced customers, or by children without direct supervision of a responsible, knowledgeable adult. If you do not fulfill these requirements, please return the kit in unused and unassembled form back to the shop where you have purchased it.

Before building and operating your NT1, YOU MUST read through all of the operating instructions and instruction manual and fully understand them to get the maximum enjoyment and prevent unnecessary damage.

CUSTOMER SUPPORT

We have made every effort to make these instructions as easy to understand as possible. However, if you have any difficulties, problems, or questions, please do not hesitate to contact the XRAY support team at info@teamxray.com. Also, please visit our Web site at www.teamxray.com to find the latest updates, set-up information, option parts, and many other goodies. We pride ourselves on taking excellent care of our customers.

You can join thousands of XRAY fans and enthusiasts in our online community at: www.teamxray.com

Read carefully and fully understand the instructions before beginning assembly. Make sure you review this entire manual, the included set-up book, and examine all details carefully. If for some reason you decide the NT1 is not what you wanted or expected, do not continue any further. Your hobby dealer cannot accept your NT1 kit for return or exchange after it has been partially or fully assembled.

Contents of the box may differ from pictures. In line with our policy of continuous product development, the exact specifications of the kit may vary without prior notice.

XRAY Europe

K Výstavisku 6992
91101 Trenčín
Slovakia, EUROPE
Phone: +421-32-7401100
Fax: +421-32-7401109
Email: info@teamxray.com

XRAY USA

RC America, 2030 Century Center Blvd #15 Irving,
TX 75062
USA
Phone: (800) 519-7221 * (214) 744-2400
Fax: (214) 744-2401
Email: xray@rcamerica.com

FAILURE TO FOLLOW THESE INSTRUCTIONS WILL BE CONSIDERED AS ABUSE AND/OR NEGLIGENCE.

SAFETY PRECAUTIONS

WARNING: This product contains a chemical known to the state of California to cause cancer and birth defects or other reproductive harm.

CAUTION: CANCER HAZARD

Wash thoroughly after using. DO NOT use product while eating, drinking or using tobacco products. May cause chronic effects to gastrointestinal tract, CNS, kidneys, and blood. MAY CAUSE BIRTH DEFECTS.

When building, using and/or operating this model always wear protective glasses and gloves.

Take appropriate safety precautions prior to operating this model. You are responsible for this model's assembly and safe operation! Please read the instruction manual before building and operating this model and follow all safety precautions. Always keep the instruction manual at hand for quick reference, even after completing the assembly. Use only genuine and original authentic XRAY parts for maximum performance.

Using any third party parts on this model will void warranty immediately.

Improper operation may cause personal and/or property damage. XRAY and its distributors have no control over damage resulting from shipping, improper construction, or improper usage. XRAY assumes and accepts no responsibility for personal and/or property damages resulting from the use of improper building materials, equipment and operations. By purchasing any item produced by XRAY, the buyer expressly warrants that he/she is in compliance with all applicable federal, state and local laws and regulation regarding the purchase, ownership and use of the item. The buyer expressly agrees to indemnify and hold harmless XRAY for all claims resulting directly or indirectly from the purchase, ownership or use of the product. By the act of assembling or operating this product, the user accepts all resulting liability. If the buyer is not prepared to accept this liability, then he/she should return this kit in new, unassembled, and unused condition to the place of purchase.

IMPORTANT NOTES – GENERAL

- This product is not suitable for children under 16 years of age without the direct supervision of a responsible and knowledgeable adult.
 - Carefully read all manufacturers warnings and cautions for any parts used in the construction and use of your model.
 - Assemble this kit only in places away from the reach of very small children.
 - First-time builders and users should seek advice from people who have building experience in order to assemble the model correctly and to allow the model to reach its performance potential.
 - Exercise care when using tools and sharp instruments.
 - Take care when building, as some parts may have sharp edges.
 - Keep small parts out of reach of small children. Children must not be allowed to put any parts in their mouth, or pull vinyl bag over their head.
 - Read and follow instructions supplied with paints and/or cement, if used (not included in kit).
 - Immediately after using your model, do NOT touch equipment on the model such as the motor and speed controller, because they generate high temperatures. You may seriously burn yourself seriously touching them.
 - Follow the operating instructions for the radio equipment at all times.
 - Do not put fingers or any objects inside rotating and moving parts, as this may cause damage or serious injury as your finger, hair, clothes, etc. may get caught.
 - Be sure that your operating frequency is clear before turning on or running your model, and never share the same frequency with somebody else at the same time. Ensure that others are aware of the operating frequency you are using and when you are using it.
 - Use a transmitter designed for ground use with RC cars. Make sure that no one else is using the same frequency as yours in your operating area. Using the same frequency at the same time, whether it is driving, flying or sailing, can cause loss of control of the RC model, resulting in a serious accident.
 - Always turn on your transmitter before you turn on the receiver in the car. Always turn off the receiver before turning your transmitter off.
 - Keep the wheels of the model off the ground when checking the operation of the radio equipment.
 - Disconnect the battery pack before storing your model.
 - When learning to operate your model, go to an area that has no obstacles that can damage your model if your model suffers a collision.
 - Remove any sand, mud, dirt, grass or water before putting your model away.
 - If the model behaves strangely, immediately stop the model, check and clear the problem.
 - To prevent any serious personal injury and/or damage to property, be responsible when operating all remote controlled models.
 - The model car is not intended for use on public places and roads or areas where its operation can conflict with or disrupt pedestrian or vehicular traffic.
 - Because the model car is controlled by radio, it is subject to radio interference from many sources that are beyond your control. Since radio interference can cause momentary loss of control, always allow a safety margin in all directions around the model in order to prevent collisions.
 - Do not use your model:
 - Near real cars, animals, or people that are unaware that an RC car is being driven.
 - In places where children and people gather
 - In residential districts and parks
 - In limited indoor spaces
 - In wet conditions
 - In the street
 - In areas where loud noises can disturb others, such as hospitals and residential areas.
 - At night or anytime your line of sight to the model may be obstructed or impaired in any way.
- To prevent any serious personal injury and/or damage to property, please be responsible when operating all remote controlled models.

IMPORTANT NOTES – NITRO ENGINES

- Always test the brakes and the throttle before starting your engine to avoid losing control of the model.
- Make sure the air filter is clean and oiled.
- Never run your engine without an air filter. Your engine can be seriously damaged if dirt and debris get inside the engine.
- For proper engine break-in, please refer to the manual that came with the engine.
- Do not run near open flames or smoke while running your model or while handling fuel.
- Some parts will be hot after operation. Do not touch the exhaust or the engine until they have cooled. These parts may reach 275°F during operation!

IMPORTANT NOTES – ELECTRICAL

- Insulate any exposed electrical wiring (using heat shrink tubing or electrical tape) to prevent dangerous short circuits. Take maximum care in wiring, connecting and insulating cables. Make sure cables are always connected securely. Check connectors for if they become loose. And if so, reconnect them securely. Never use R/C models with damaged wires. A damaged wire is extremely dangerous, and can cause short-circuits resulting in fire. Please have wires repaired at your local hobby shop.
- Low battery power will result in loss of control. Loss of control can occur due to a weak battery in either the transmitter or the receiver. Weak running battery may also result in an out of control car if your car's receiver power is supplied by the running battery. Stop operation immediately if the car starts to slow down.
- When not using RC model, always disconnect and remove battery.
- Do not disassemble battery or cut battery cables. If the running battery short-circuits, approximately 300W of electricity can be discharged, leading to fire or burns. Never disassemble battery or cut battery cables.
- Use a recommended charger for the receiver and transmitter batteries and follow the instructions

IMPORTANT NOTES – NITRO FUEL

- Handle fuel only outdoors. Never handle nitro fuel indoors, or mix nitro fuel in a place where ventilation is bad.
- Only use nitro fuel for R/C models. Do not use gasoline or kerosene in R/C models as it may cause a fire or explosion, and ruin your engine.
- Nitro fuel is highly flammable, explosive, and poisonous. Never use fuel indoors or in places with open fires and sources of heat.
- Always keep the fuel container cap tightly shut.
- Always read the warning label on the fuel container for safety information.
- Nitro-powered model engines emit poisonous vapors and gasses. These vapors irritate eyes and can be highly dangerous to your health. We recommend wearing rubber or vinyl gloves to avoid direct contact with nitro fuel.
- Nitro fuel for RC model cars is made of the combination of the methyl alcohol, castor or synthetic oil,

correctly. Over-charging, incorrect charging, or using inferior chargers can cause the batteries to become dangerously hot. Recharge battery when necessary. Continual recharging may damage battery and, in the worst case, could build up heat leading to fire. If battery becomes extremely hot during recharging, please ask your local hobby shop for check and/or repair and/or replacement.

- Regularly check the charger for potential hazards such as damage to the cable, plug, casing or other defects. Ensure that any damage is rectified before using the charger again. Modifying the charger may cause short-circuit or overcharging leading to a serious accident. Therefore do not modify the charger.
- Always unplug charger when recharging is finished.
- Do not recharge battery while battery is still warm. After use, battery retains heat. Wait until it cools down before charging.
- Do not allow any metal part to short circuit the receiver batteries or other electrical/electronic device on the model.
- Immediately stop running if your RC model gets wet as may cause short circuit.
- Please dispose of batteries responsibly. Never put batteries into fire.

nitro methane etc. The flammability and volatility of these elements is very high, so be very careful during handling and storage of nitro fuel.

- Keep nitro fuel away from open flame, sources of heat, direct sunlight, high temperatures, or near batteries.
- Store fuel in a cool, dry, dark, well-ventilated place, away from heating devices, open flames, direct sunlight, or batteries. Keep nitro fuel away from children.
- Do not leave the fuel in the carburetor or fuel tank when the model is not in use. There is danger that the fuel may leak out.
- Wipe up any spilled fuel with a cloth
- Be aware of spilled or leaking fuel. Fuel leaks can cause fires or explosions.
- Do not dispose of fuel or empty fuel containers in a fire. There is danger of explosion.

R/C & BUILDING TIPS

- Make sure all fasteners are properly tightened. Check them periodically.
- Make sure that chassis screws do not protrude from the chassis.
- For the best performance, it is very important that great care is taken to ensure the free movement of all parts.
- Clean all ball-bearings so they move very easily and freely.
- Tap or pre-thread the plastic parts when threading screws.
- Self-tapping screws cut threads into the parts when being tightened. Do not use excessive force when tightening the self-tapping screws because you may strip out the thread in the plastic. We recommended

you stop tightening a screw when you feel some resistance.

- Ask your local hobby shop for any advice.

Please support your local hobby shop. We at XRAY Model Racing Cars support all local hobby dealers. Therefore we ask you, if at all possible, to purchase XRAY products at your hobby dealer and give them your support like we do. If you have difficulty finding XRAY products, please check out www.teamxray.com to get advice, or contact us via email at info@teamxray.com, or contact the XRAY distributor in your country.

WARRANTY

XRAY guarantees this model kit to be free from defects in both material and workmanship within 30 days of purchase. The total monetary value under warranty will in no case exceed the cost of the original kit purchased. This warranty does not cover any components damaged by use or modification or as a result of wear. Part or parts missing from this kit must be reported within 30 days of purchase. No part or parts will be sent under warranty without proof of purchase. Should you find a defective or missing part, contact the local distributor. Service and customer support will be provided through local hobby store where you have purchased the kit, therefore make sure to purchase any XRAY products at your local hobby store. This model racing car is considered to be a high-performance racing vehicle. As such this vehicle will be used in an extreme range of conditions and situations, all which may cause premature wear or failure of any component. XRAY has no control over usage of vehicles once they leave the dealer, therefore XRAY can only offer warranty against all manufacturer's defects in materials, workmanship, and assembly at point of sale and before use. No warranties are expressed or implied that cover damage caused by what is considered normal use, or cover or imply how long any model cars' components or electronic components will last before requiring replacement.

Due to the high performance level of this model car you will need to periodically maintain and replace consumable components. Any and all warranty coverage will not cover replacement of any part or component damaged by neglect, abuse, or improper or unreasonable use. This includes but is not limited to damage from crashing, chemical and/or water damage, excessive moisture, improper or no maintenance, or user

modifications which compromise the integrity of components. Warranty will not cover components that are considered consumable on RC vehicles. XRAY does not pay nor refund shipping on any component sent to XRAY or its distributors for warranty. XRAY reserves the right to make the final determination of the warranty status of any component or part.

Limitations of Liability

XRAY makes no other warranties expressed or implied. XRAY shall not be liable for any loss, injury or damages, whether direct, indirect, special, incidental, or consequential, arising from the use, misuse, or abuse of this product and/or any product or accessory required to operate this product. In no case shall XRAY's liability exceed the monetary value of this product.

Take adequate safety precautions prior to operating this model. You are responsible for this model's assembly and safe operation.

Disregard of the any of the above cautions may lead to accidents, personal injury, or property damage. XRAY MODEL RACING CARS assumes no responsibility for any injury, damage, or misuse of this product during assembly or operation, nor any additions that may arise from the use of this product.

All rights reserved.

QUALITY CERTIFICATE

XRAY MODEL RACING CARS uses only the highest quality materials, the best compounds for molded parts and the most sophisticated manufacturing processes of TQM (Total Quality Management). We guarantee that all parts of a newly-purchased kit are manufactured with the highest regard to quality. However, due to the many factors inherent in model racecar competition, we cannot guarantee any parts once you start racing the car. Products which have been worn out, abused, neglected or improperly operated will not be covered under warranty. We wish you enjoyment of this high-quality and high-performance RC car and wish you best success on the track!

Please note that raw materials such as aluminum, steel, brass, fibreglass, or carbon fibre may have small scratches on the surface which is a standard characteristic of any raw material. Scratches on the surface of any materials are NOT considered to be material defects.

Products may potentially have small amounts of corrosion on them. This may be caused by variances in weather during different times of the year, humidity in the shop or during shipping, and other contributing factors. Even though we have taken all precautions and protection methods to prevent corrosion, these small amounts of corrosion (if present) are unavoidable and considered to be acceptable.

In line with our policy of continuous product development, the exact specifications of the kit may vary. In the unlikely event of any problems with your new kit, you should contact the model shop where you purchased it, quoting the part number. We do reserve all rights to change any specification without prior notice. All rights reserved.

SYMBOLS USED

Apply threadlock	Assemble left and right sides the same way	Number of teeth	Use pliers
Apply oil (may indicate specific type)	Ensure smooth non-binding movement	Scale	Part bags used
Apply cyanoacrylate (CA) glue	Cut off remaining material	Pay attention here	Assemble in the specified order
Apply grease	Assemble as many times as specified (here twice)	Follow tip here	Follow Set-Up Book
Assembly view	Detail view		

INCLUDED

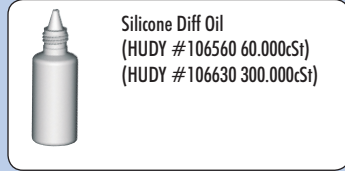
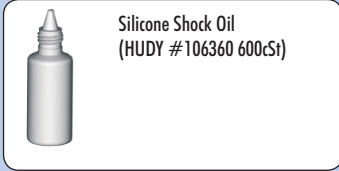

NOT INCLUDED

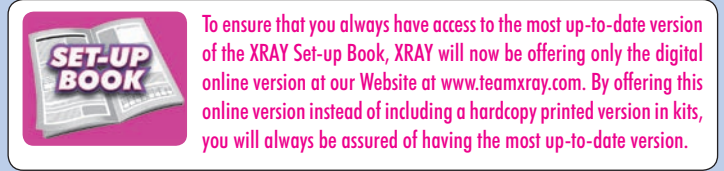

TOOLS REQUIRED

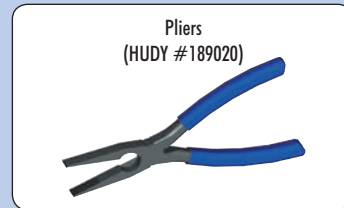
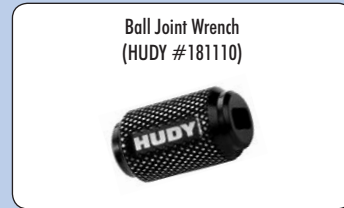
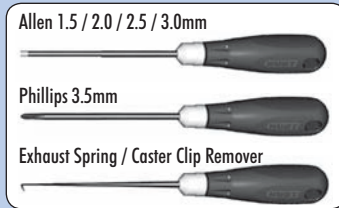

EQUIPMENT REQUIRED

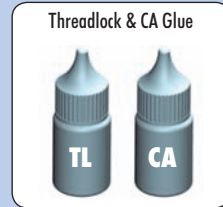
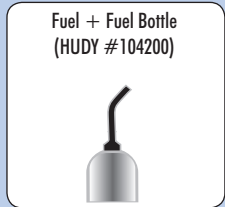
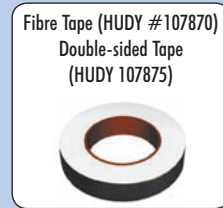
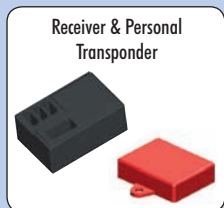

1. FRONT GEAR DIFFERENTIAL & SOLID AXLE

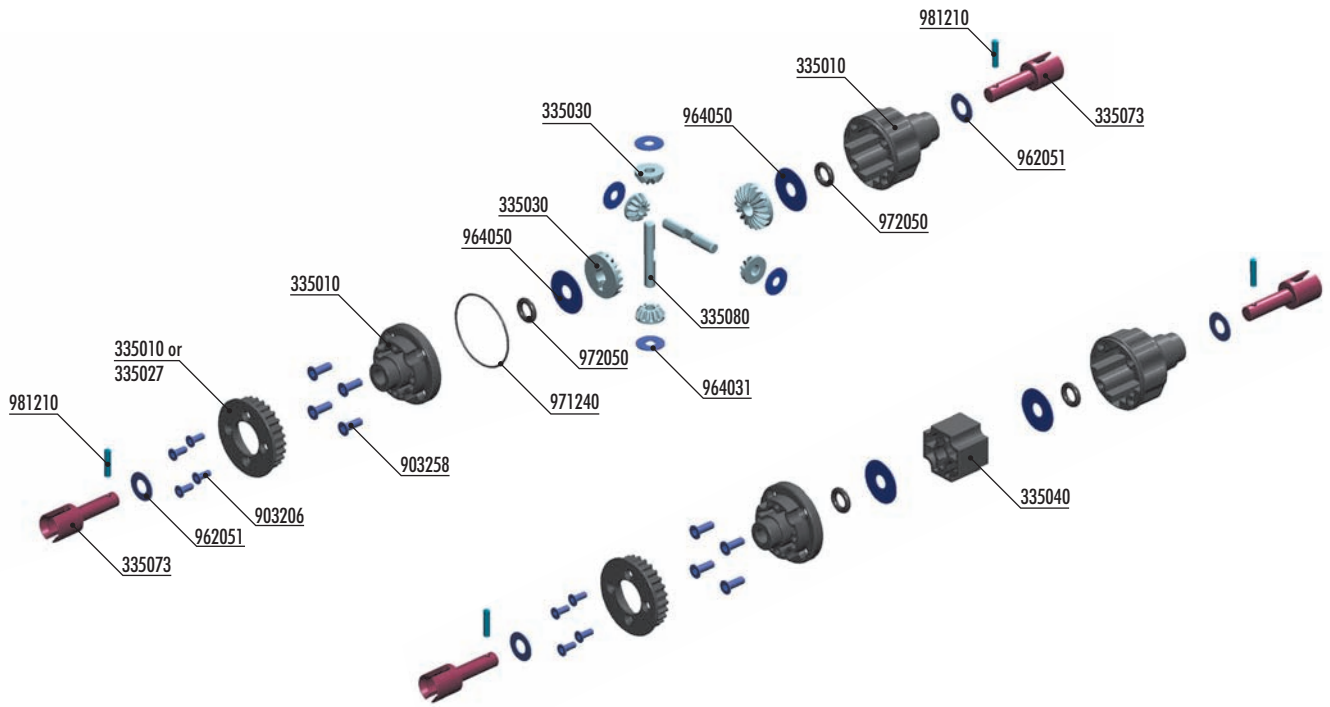

#335081
ALU DIFFERENTIAL PIN - HARDCOATED (2)



#304932
GRAPHITE GEAR DIFF BEVEL & SATELLITE GEARS (2+4)



#104002
HUDY AIR VAC – VACUUM PUMP - ON-ROAD



#335100
XRAY MULTI DIFFERENTIAL - ONE-WAY - SOLID - SET

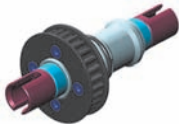

#335180
XRAY SUPERLIGHT SOLID AXLE SET - HUDY SPRING STEEL™



BAG



- 335000 FRONT GEAR DIFFERENTIAL - SET
- 335010 COMPOSITE FRONT DIFF. CASE, COVER & 27T BELT PULLEY
- 335027 COMPOSITE TIMING BELT PULLEY 27T
- 335030 DIFF BEVEL & SATELLITE GEARS (2+4)
- 335040 COMPOSITE SOLID AXLE ADAPTER
- 335073 LIGHTWEIGHT DIFF OUTDRIVE ADAPTER - LONG - HUDY SPRING STEEL™ (2)
- 335080 DIFF PIN (2)

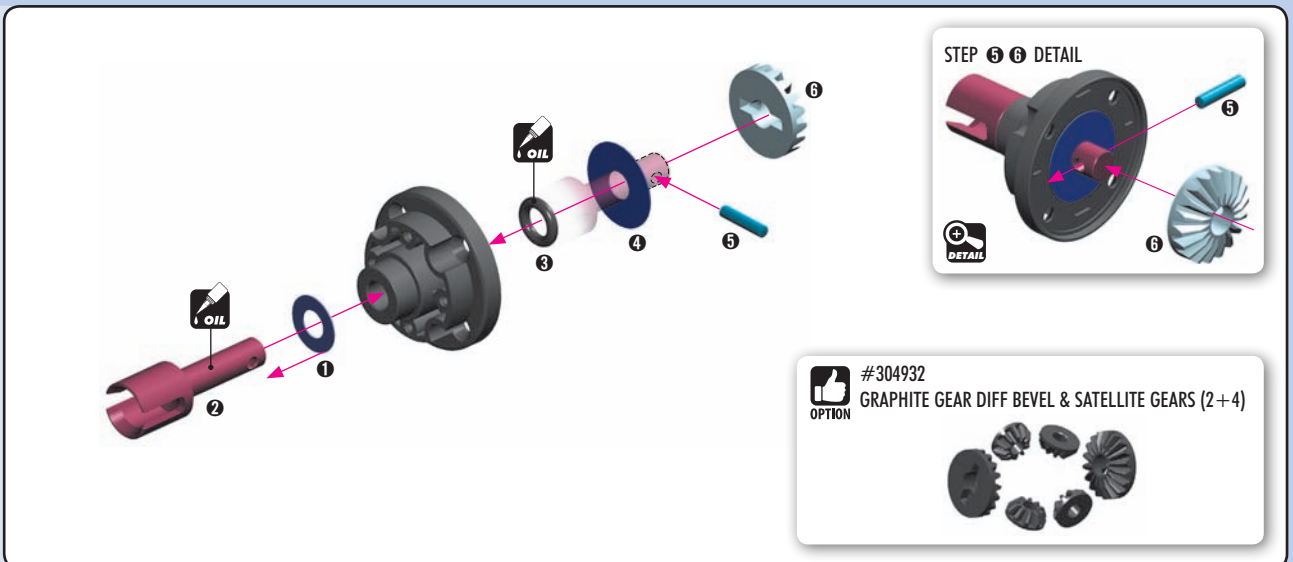

- 903206 HEX SCREW SFH M2x6 (10)
- 903258 HEX SCREW SFH M2.5x8 (10)
- 962051 WASHER S 5x10x0.2 (10)
- 964031 WASHER S 3.5x10x0.2 (10)
- 964050 WASHER S 5x15x0.3 (10)
- 971240 SILICONE O-RING 24x0.7 (10)
- 972050 SILICONE O-RING 5x2 (10)
- 981210 PIN 2x10 (10)



#304932
GRAPHITE GEAR DIFF BEVEL & SATELLITE GEARS (2+4)



1. FRONT GEAR DIFFERENTIAL & SOLID AXLE

-  962051
S 5x10x0.2
-  964050
S 5x15x0.3
-  972050 981210
O 5x2 P 2x10

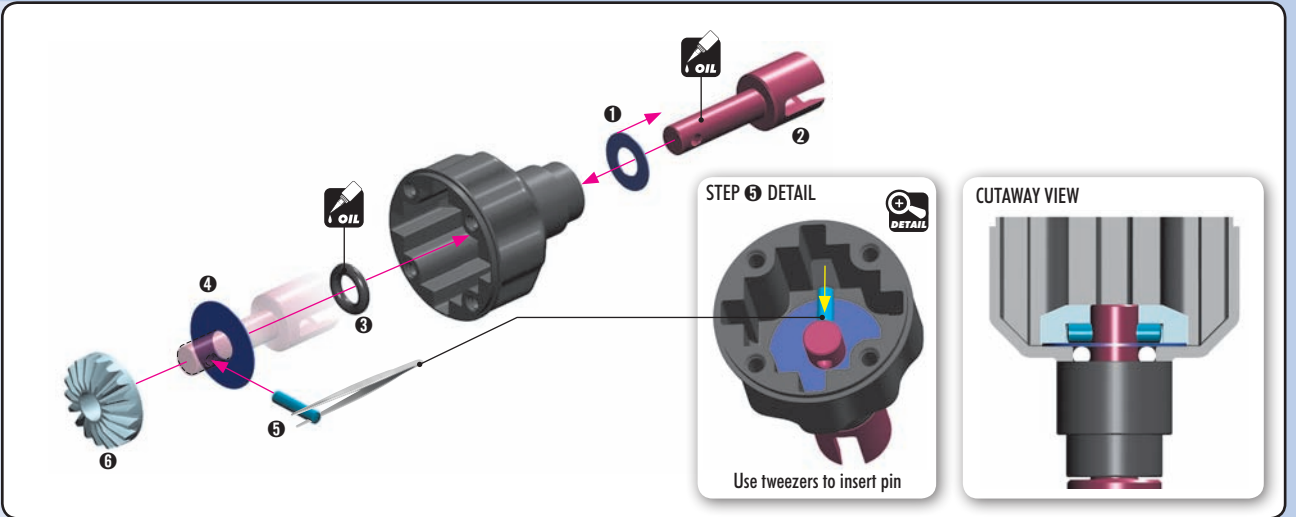

STEP 5 DETAIL
Use tweezers to insert pin

CUTAWAY VIEW

Silicone oil **300.000cSt**



TIP Fill differential up to the top of the diff pins. DO NOT fill the diff to the top of the housing.

Remove the nozzle of the bottle to allow easy filling of the diff.

TO ENSURE YOU HAVE THE SAME AMOUNT OF OIL FROM REBUILD TO REBUILD, DO THE FOLLOWING:

#107865 HUDY Ultimate Digital Pocket Scale 300g ± 0.01g



12.70g

1 Put the diff (without oil) on the scale and check the weight (approximately 12.70g)

Silicone oil **300.000cSt**



14.70g

2 Slowly pour oil into the diff and watch the weight. Add 2.0g of oil into the diff. The approximate weight of the diff including oil is 14.70g.

12.70g + 2.0g = 14.70g

-  964031
S 3.5x10x0.2



1

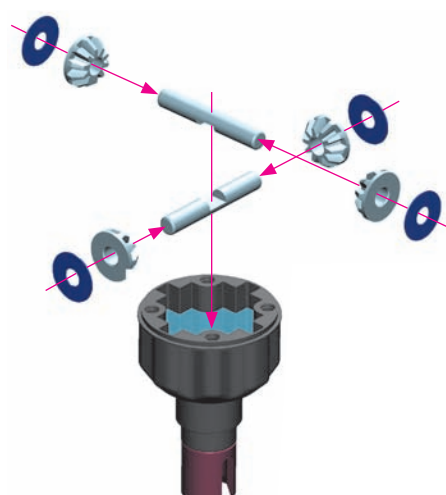

#335081
ALU DIFFERENTIAL PIN - HARDCOATED (2)
OPTION



2

Push down

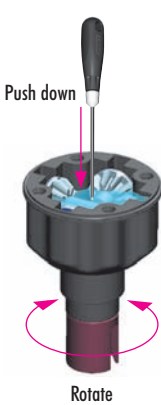

Rotate

3

Wait approx. 5min



#104002
HUDY AIR VAC – VACUUM PUMP
OPTION



1. FRONT GEAR DIFFERENTIAL & SOLID AXLE



903258
SFH M2.5x8

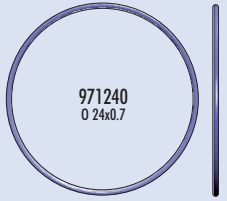

971240
O 24x0.7



After disassembling the differential, the large O-ring may have an increased size and may be more difficult to re-install. We recommend either replacing the O-ring with a new one or carefully re-inserting the old O-ring in the diff cover.

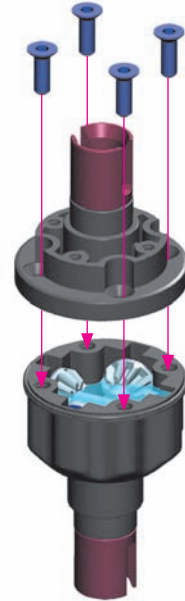

Tighten the screws
equally but do NOT
tighten them completely

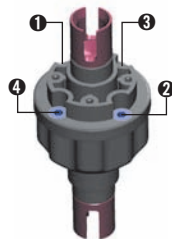

Finish tightening in
this order



903206
SFH M2x6

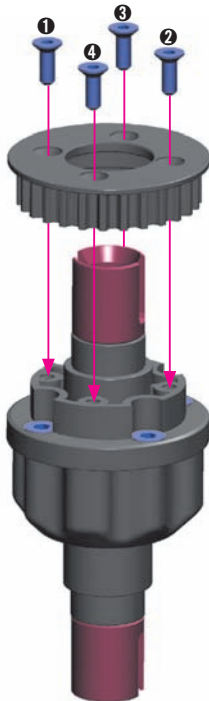

SOLID AXLE



903258
SFH M2.5x8



962051
S 5x10x0.2



964050
S 5x15x0.3



972050
O 5x2



981210
P 2x10

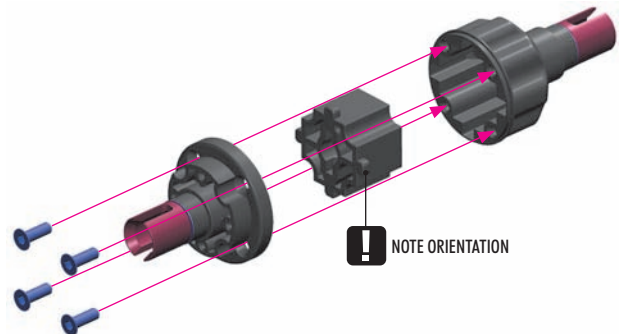
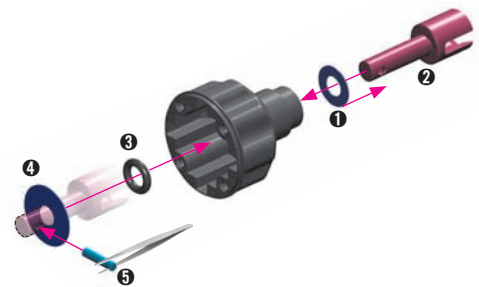
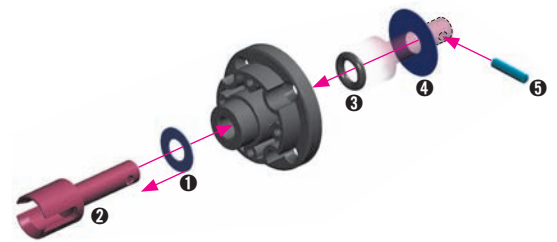

The front diff can be easily changed into a solid axle. Remove the internal gears and replace with the solid axle locking body. DO NOT add silicone oil inside the housing when making a solid axle.

1. REAR GEAR DIFFERENTIAL

#304932
GRAPHITE GEAR DIFF BEVEL & SATELLITE GEARS (2+4)
 OPTION



#335081
ALU DIFFERENTIAL PIN - HARDCOATED (2)
 OPTION

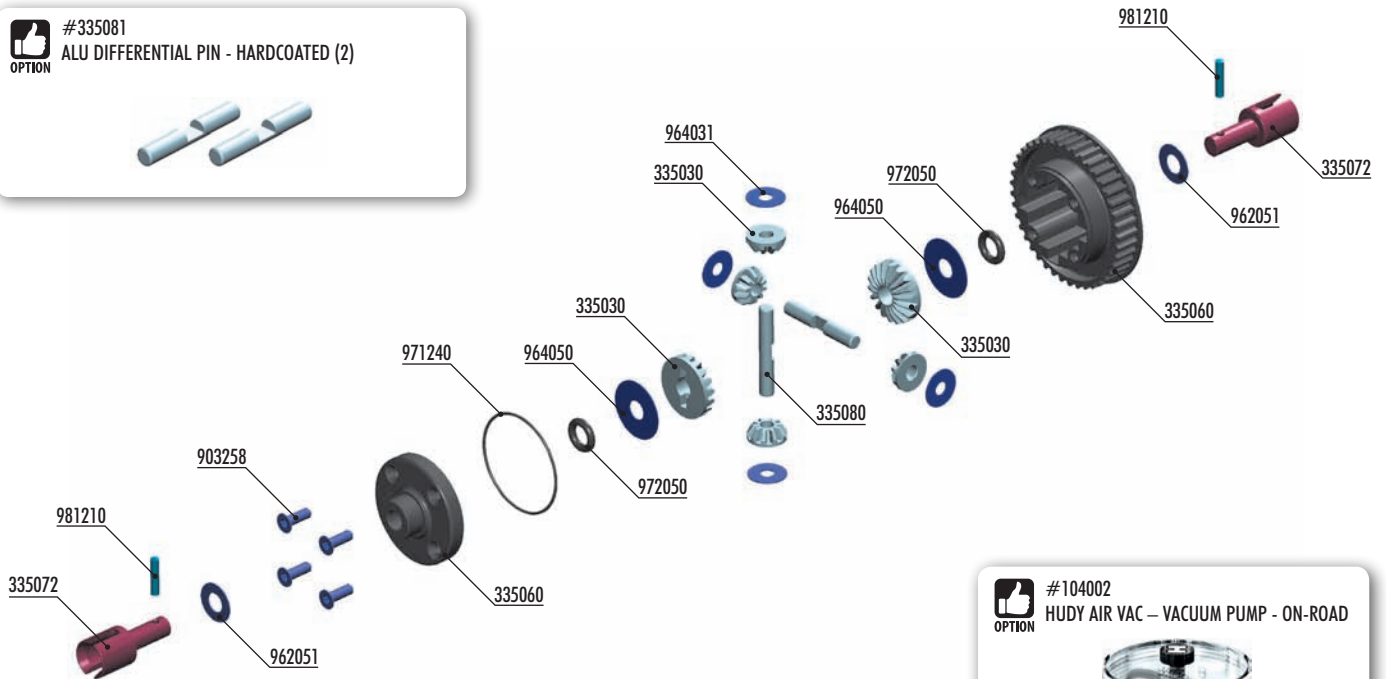

#104002
HUDY AIR VAC - VACUUM PUMP - ON-ROAD
 OPTION



BAG

01.2

335030 DIFF BEVEL & SATELLITE GEARS (2+4)
 335050 REAR GEAR DIFFERENTIAL - SET
 335060 COMPOSITE REAR DIFF CASE & COVER
 335072 LIGHTWEIGHT DIFF OUTDRIVE ADAPTER - HUDY SPRING STEEL™ (2)
 335080 DIFF PIN (2)

903258 HEX SCREW SFH M2.5x8 (10)
 962051 WASHER S 5x10x0.2 (10)
 964031 WASHER S 3.5x10x0.2 (10)
 964050 WASHER S 5x15x0.3 (10)
 971240 SILICONE O-RING 24x0.7 (10)
 972050 SILICONE O-RING 5x2 (10)
 981210 PIN 2x10 (10)

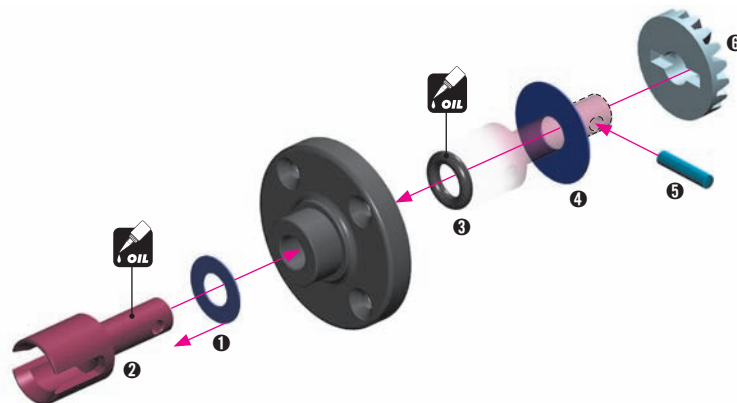

STEP 5 6 DETAIL

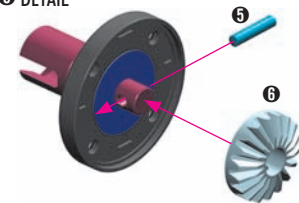

#304932
GRAPHITE GEAR DIFF BEVEL & SATELLITE GEARS (2+4)
 OPTION



1. REAR GEAR DIFFERENTIAL

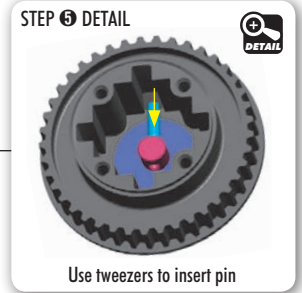
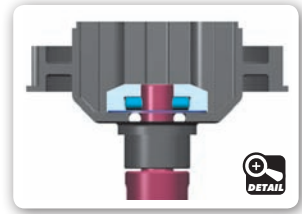
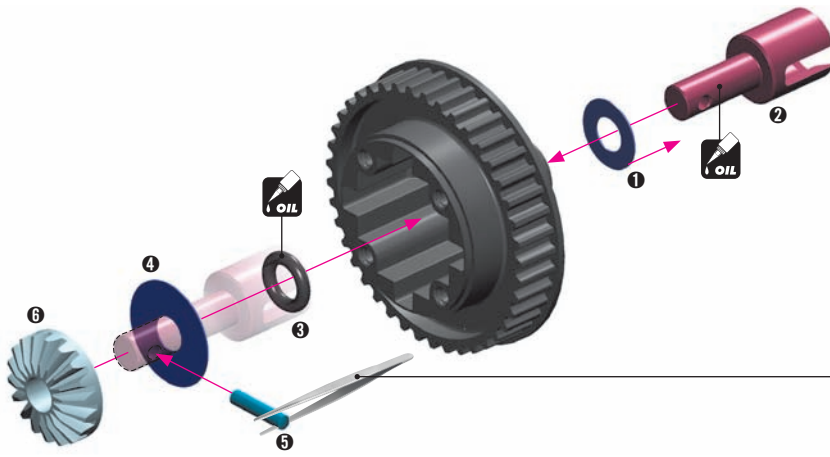
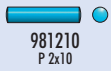
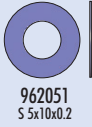

Silicone oil 60.000cSt

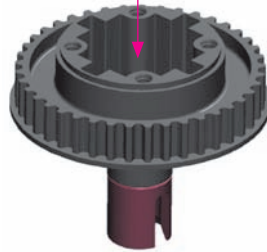

TIP

Fill differential up to the top of the diff pins. DO NOT fill the diff to the top of the housing.

Remove the nozzle of the bottle to allow easy filling of the diff.



TO ENSURE YOU HAVE THE SAME AMOUNT OF OIL FROM REBUILD TO REBUILD, DO THE FOLLOWING:

#107865 HUDY Ultimate Digital Pocket Scale 300g ± 0.01g

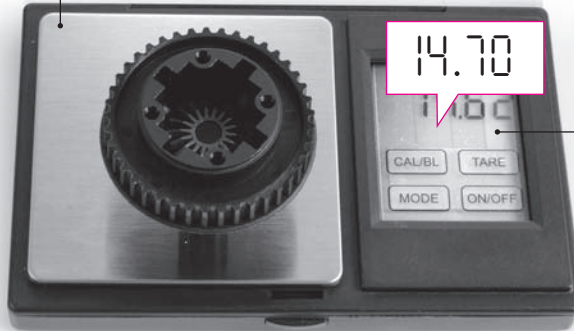

14.70g

1 Put the diff (without oil) on the scale and check the weight (approximately 14.70g)



$$14.70g + 2.0g = 16.70g$$

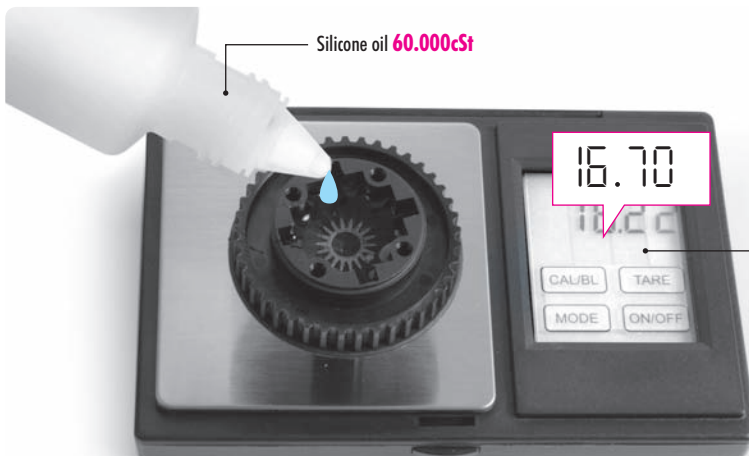

Silicone oil 60.000cSt

16.70g

2 Slowly pour oil into the diff and watch the weight. Add 2.0g of oil into the diff. The approximate weight of the diff including oil is 16.70g.

1. REAR GEAR DIFFERENTIAL



964031
S 3.5x10x0.2



GEAR DIFF ADJUSTMENT

1

#335081
ALU DIFFERENTIAL PIN - HARDCOATED (2)

2

Push down
Rotate

3

Wait approx. 5min

#104002
HUDY AIR VAC – VACUUM PUMP
OPTION

971240
O 24x0.7

OIL

!

After disassembling the differential, the large O-ring may have an increased size and may be more difficult to re-install. We recommend either replacing the O-ring with a new one or carefully re-inserting the old O-ring in the diff cover.

903258
SFH M2.5x8

DETAIL

Tighten the screws equally but do NOT tighten them completely.

Finish tightening in this order.

2. REAR SUSPENSION

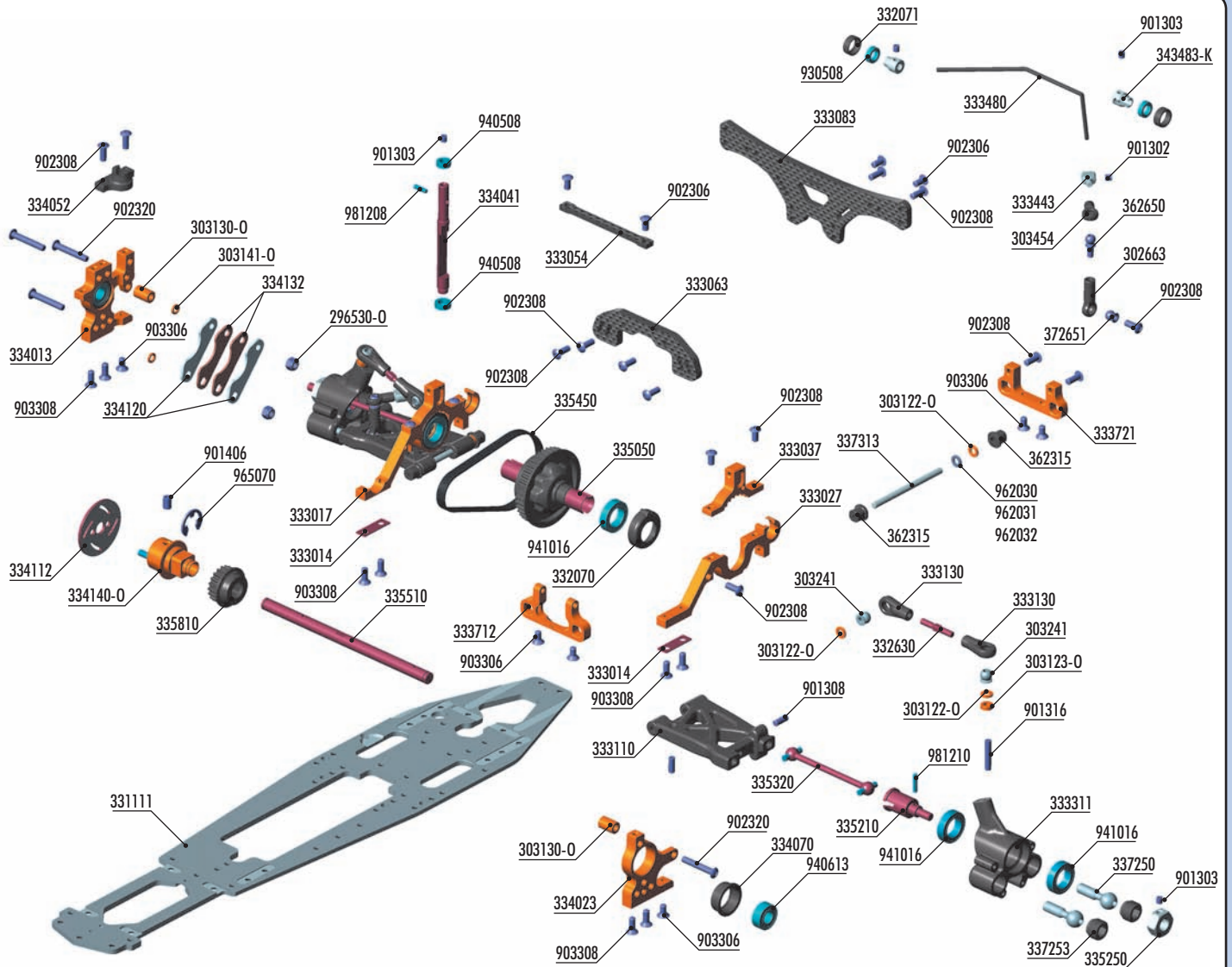

BAG

02

- | | | | |
|----------|--|----------|---|
| 296530-0 | ALU NUT M3 - ORANGE (10) | 335050 | REAR GEAR DIFFERENTIAL - SET |
| 302663 | COMPOSITE BALL JOINT 4.9MM - OPEN - V2 (8) | 335210 | DRIVE AXLE - HUDY SPRING STEEL™ |
| 303121-0 | ALU SHIM 3x6x0.5MM - ORANGE (10) | 335250 | ALU WHEEL HUB 12MM - BLACK (2) |
| 303122-0 | ALU SHIM 3x6x1.0MM - ORANGE (10) | 335320 | DRIVE SHAFT - 60 MM - HUDY SPRING STEEL™ |
| 303123-0 | ALU SHIM 3x6x2.0MM - ORANGE (10) | 335450 | PUR®-REFINFORCED DRIVE BELT REAR 5.5 x 177 MM |
| 303130-0 | ALU SHIM 3x6x9.0MM - ORANGE (10) | 335510 | 2-SPEED SHAFT - V2 |
| 303141-0 | ALU SHIM 3x5x1.0MM - ORANGE (10) | 335810 | COMPOSITE BELT PULLEY 20T - 2-SPEED-CENTER |
| 303241 | BALL UNIVERSAL 5.8 MM HEX (4) | 337250 | STEEL PIVOT BALL 8.4 MM (2) |
| 303454 | BALL JOINT 4.9MM - OPEN (4) | 337253 | COMPOSITE ADJUSTING NUT M10x1 WITH BALL CUP (4) |
| 331111 | CHASSIS 3MM - CNC MACHINED - SWISS 7075 T6 | 337313 | REAR LOWER INNER PIVOT PIN (2) |
| 332070 | COMPOSITE ADJUST. BALL-BEARING HUB (4) | 343483-K | ALU CUTTED ANTI-ROLL BAR COLLAR ø2.3 - BLACK (2) |
| 332071 | COMPOSITE BALL-BEARING HUB (4) | 362315 | ECCENTRIC BUSHING SET (2) |
| 332630 | ADJ. TURNBUCKLE L/R 25 MM - HUDY SPRING STEEL™ (2) | 362650 | BALL END 4.9MM WITH THREAD 6MM (2) |
| 333014 | BULKHEAD SHIM (2) | 372651 | PIVOT BALL UNIVERSAL 4.9 MM - HUDY SPRING STEEL (2) |
| 333017 | ALU LOWER BULKHEAD REAR RIGHT - SWISS 7075 T6 | 901302 | HEX SCREW SB M3x2.5 (10) |
| 333027 | ALU LOWER BULKHEAD REAR LEFT - SWISS 7075 T6 | 901303 | HEX SCREW SB M3x3 (10) |
| 333037 | ALU UPPER CLAMP REAR (L+R) - SWISS 7075 T6 | 901308 | HEX SCREW SB M3x8 (10) |
| 333054 | GRAPHITE REAR BULKHEAD BRACE | 901316 | HEX SCREW SB M3x16 (10) |
| 333063 | GRAPHITE ROLL-CENTER BRIDGE | 901406 | HEX SCREW SB M4x6 (10) |
| 333083 | GRAPHITE SHOCK TOWER REAR | 902306 | HEX SCREW SH M3x6 (10) |
| 333110 | COMPOSITE SUSPENSION ARM REAR LOWER - V2 | 902308 | HEX SCREW SH M3x8 (10) |
| 333130 | COMPOSITE REAR UPPER CAMBER LINK BALL JOINT 5.8 MM (4) | 902320 | HEX SCREW SH M3x20 (10) |
| 333311 | COMPOSITE UPRIGHT REAR FOR AERO DISC | 903306 | HEX SCREW SFH M3x6 (10) |
| 333443 | ALU ANTI-ROLL BAR COLLAR ø2.2 (2) | 903308 | HEX SCREW SFH M3x8 (10) |
| 333480 | ANTI-ROLL BAR FOR BALL-BEARINGS - REAR 2.0 MM | 930508 | BALL-BEARING 5x8x2.5 STEEL SEALED - OIL (2) |
| 333712 | ALU REAR LOWER 1-PIECE SUSPENSION HOLDER - FRONT - RF | 940508 | BALL-BEARING 5x8x2.5 RUBBER SEALED - OIL (2) |
| 333721 | ALU REAR LOWER 1-PIECE SUSPENSION HOLDER - REAR - RR | 940613 | BALL-BEARING 6x13x5 RUBBER SEALED - OIL (2) |
| 334013 | ALU BRAKE STAND - SWISS 7075 T6 | 941016 | BALL-BEARING 10x16x4 RUBBER SEALED - OIL (2) |
| 334023 | ALU 2-SPEED HOLDER - SWISS 7075 T6 - SET | 962030 | WASHER S 3x6x0.3 (10) |
| 334041 | BRAKE CAM POST - STEEL | 962031 | WASHER S 3x6x0.1 (10) |
| 334052 | COMPOSITE BRAKE UPPER PLATE | 962032 | WASHER S 3x6x0.2 (10) |
| 334070 | COMPOSITE 6x13x5 BALL-BEARING HUB (2) | 965070 | E-CLIP 7 (10) |
| 334112 | VENTILATED BRAKE DISK - LASER CUT - PRECISION-GROUND | 981208 | PIN 2x8 (10) |
| 334120 | HARDENED STEEL BRAKE PAD - LASER CUT (2) | 981210 | PIN 2x10 (10) |
| 334132 | BRAKE PAD "SLS" (2) | | |
| 334140-0 | BRAKE DISK ADAPTER - ALU 7075 T6 - ORANGE | | |

2. REAR SUSPENSION



903306
SFH M3x6

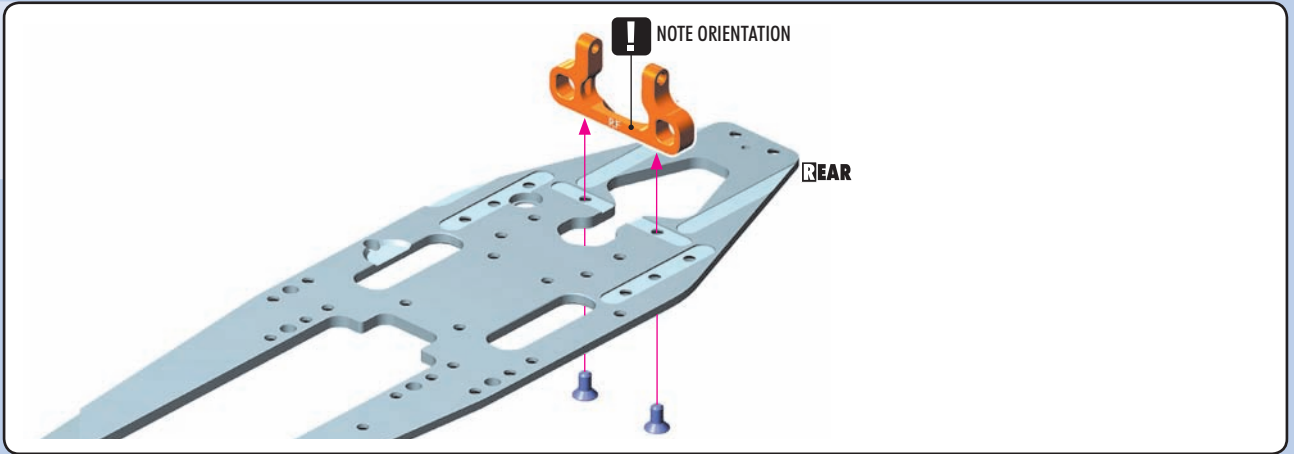

902308
SH M3x8

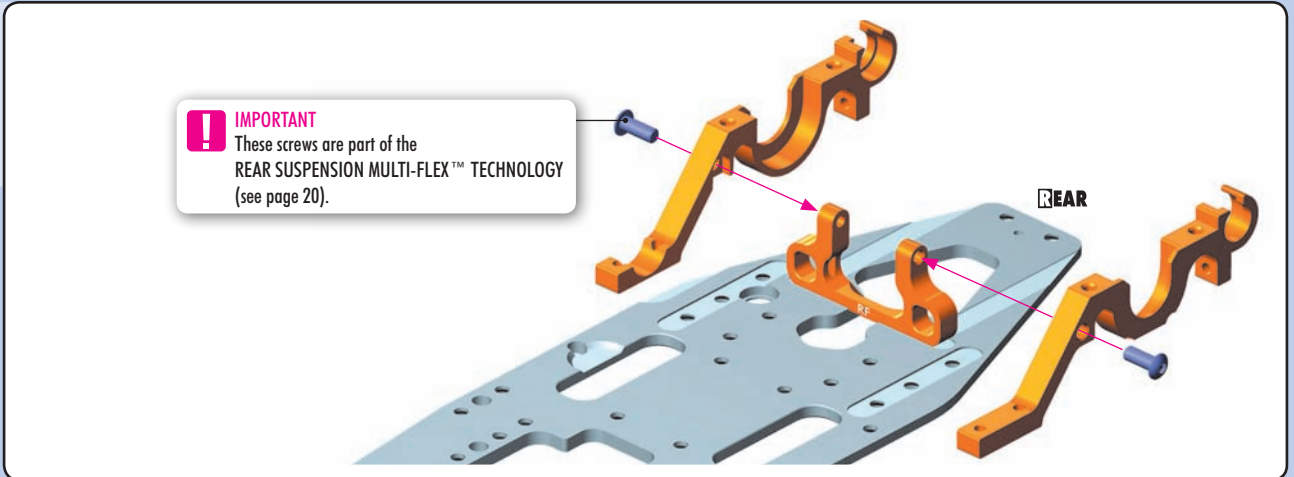

903308
SFH M3x8

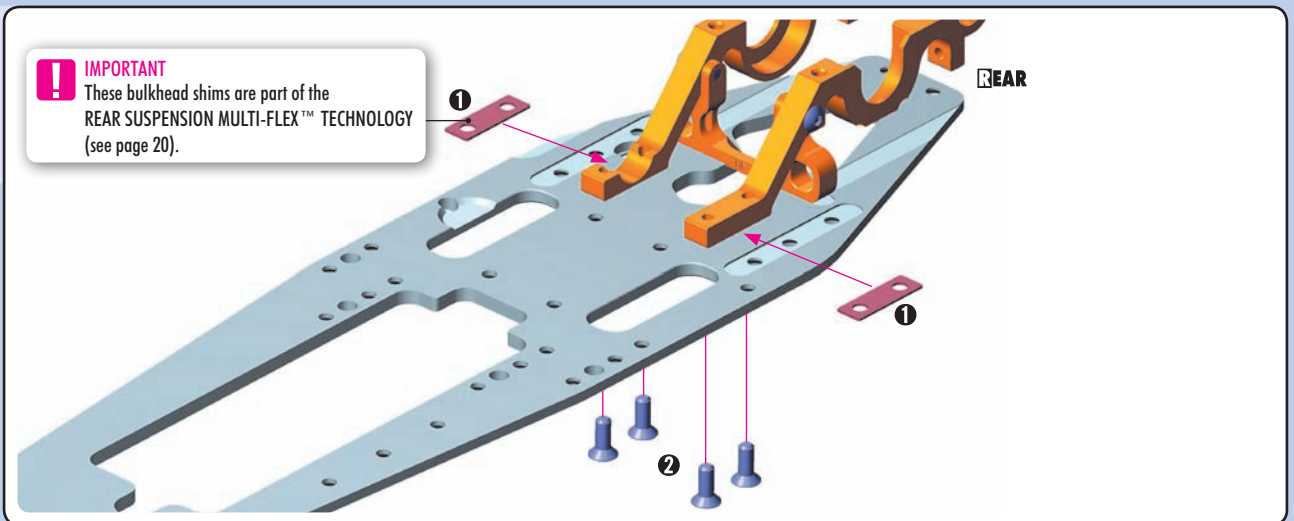

901308
SB M3x8

2x REAR ARMS

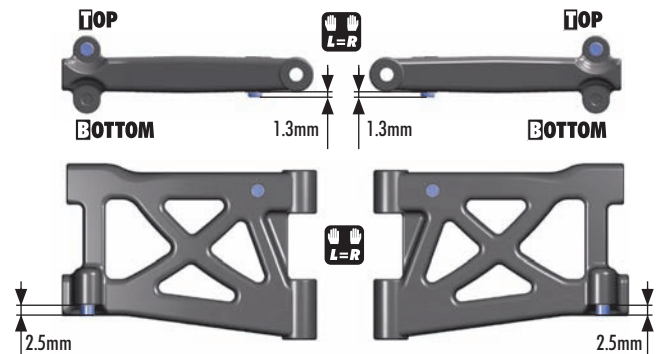
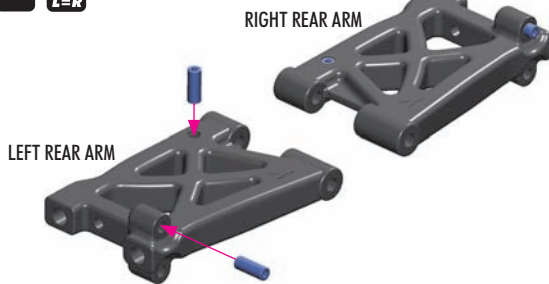

OPTION

REAR SUSPENSION ARMS

#333110	MEDIUM	INCLUDED
#333111	HARD	OPTION



2. REAR SUSPENSION

10
303122-0
SHIM 3x6x1



902308
SH M3x8



903306
SFH M3x6

962030
SHIM 3x6x0.3

962032
SHIM 3x6x0.2

962031
SHIM 3x6x0.1

2x
L=R

REAR RIGHT REAR ARM

3x6x1mm

INITIAL SETTING

1 0.5 0 0.5 1

Composite eccentric bushings

! SHIMS 0.1 / 0.2 / 0.3mm
Use included shims to eliminate suspension play.

NOTE ORIENTATION **!**

INITIAL SETTING

1 0.5 0 0.5 1

Composite eccentric bushings

L=R It is extremely important that the arms move freely on the pivot pins. If they do not, use the #107633 HUDY Arm Reamer to slightly resize the holes in the arms.

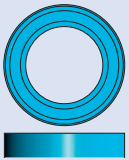

941016
BB 10x16x4

! **NOTE ORIENTATION**
Both bushings must be in same position

BEARING OIL **OIL**

#335452
OPTION LOW FRICTION DRIVE BELT REAR 5.5 X 177 MM

BEARING OIL **OIL**

! **NOTE ORIENTATION**
Both bushings must be in same position

REAR



902308
SH M3x8

! **NOTE ORIENTATION**
Hole is from outside

DETAIL

LEFT **RIGHT**

REAR

L=R **REAR BELT TENSION ADJUSTMENT** **DETAIL**

INITIAL POSITION

REAR **FRONT**

TO TIGHTEN REAR BELT: Rotate both rear nylon hubs in arrow direction **B**
TO LOOSEN REAR BELT: Rotate both rear nylon hubs in arrow direction **A**

2. REAR SUSPENSION

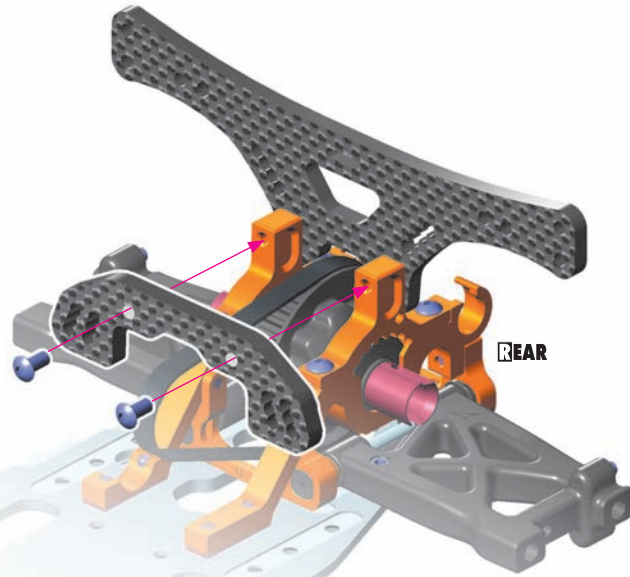
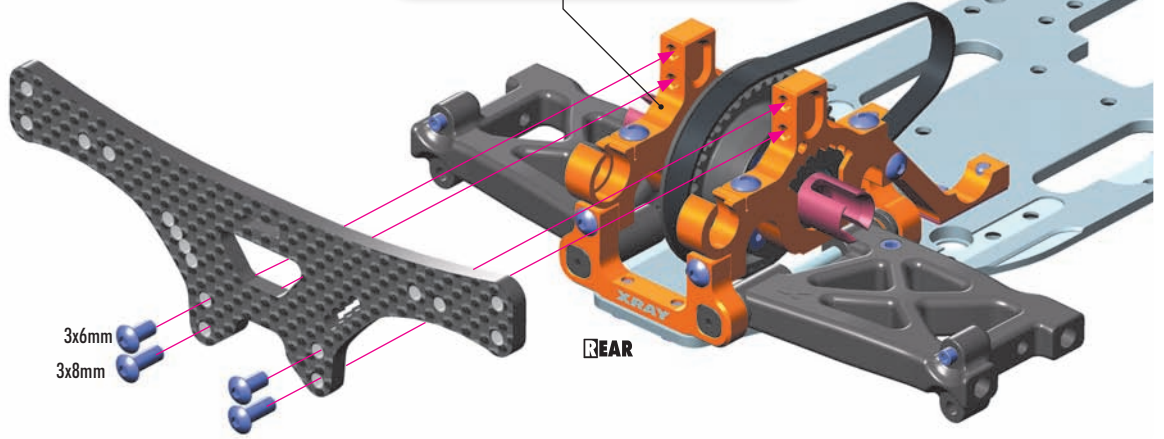
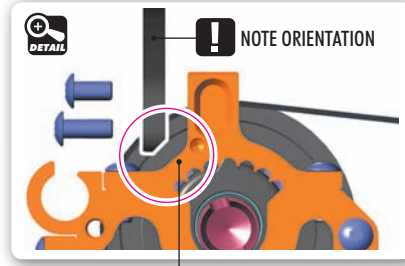

2x

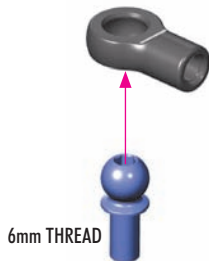

TIP Install the pivot balls with Professional Multi Tool (HUDY #183011)



2x

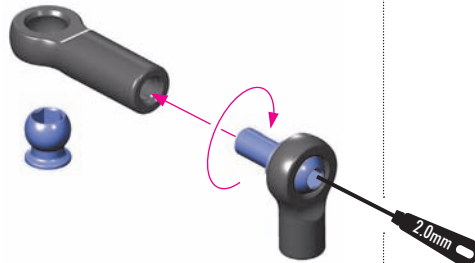

2x

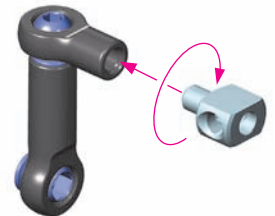

2. REAR SUSPENSION

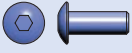

902308
SH M3x8

2x
L=R

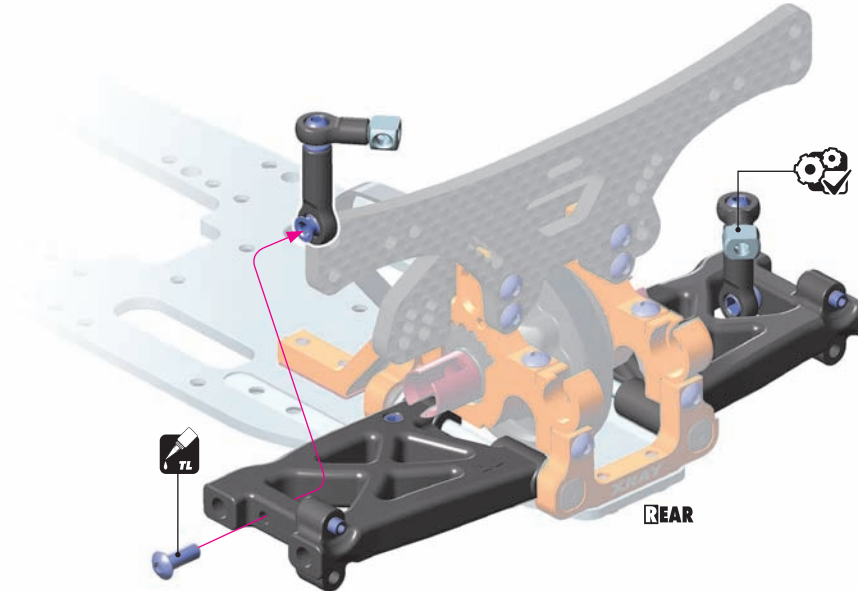

930508
BB 5x8x2.5

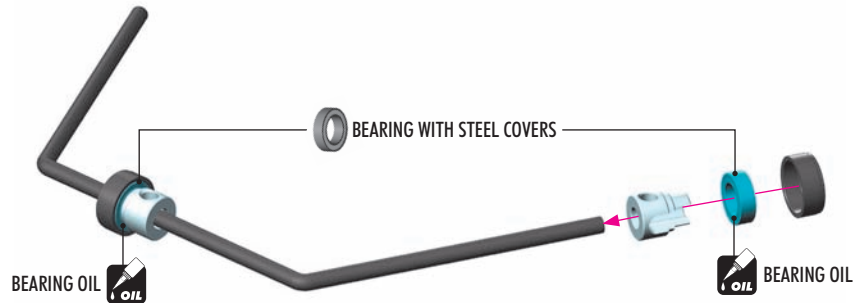

OPTION

REAR ANTI-ROLL BARS			COLLARS	
#333478	1.8mm	OPTION		#333443 + 343483-K
#333480	2.0mm	INCLUDED		INCLUDED
#333482	2.2mm	OPTION		INCLUDED
#333484	2.4mm	OPTION		#333442 + 343482-K
#333486	2.6mm	OPTION		OPTION

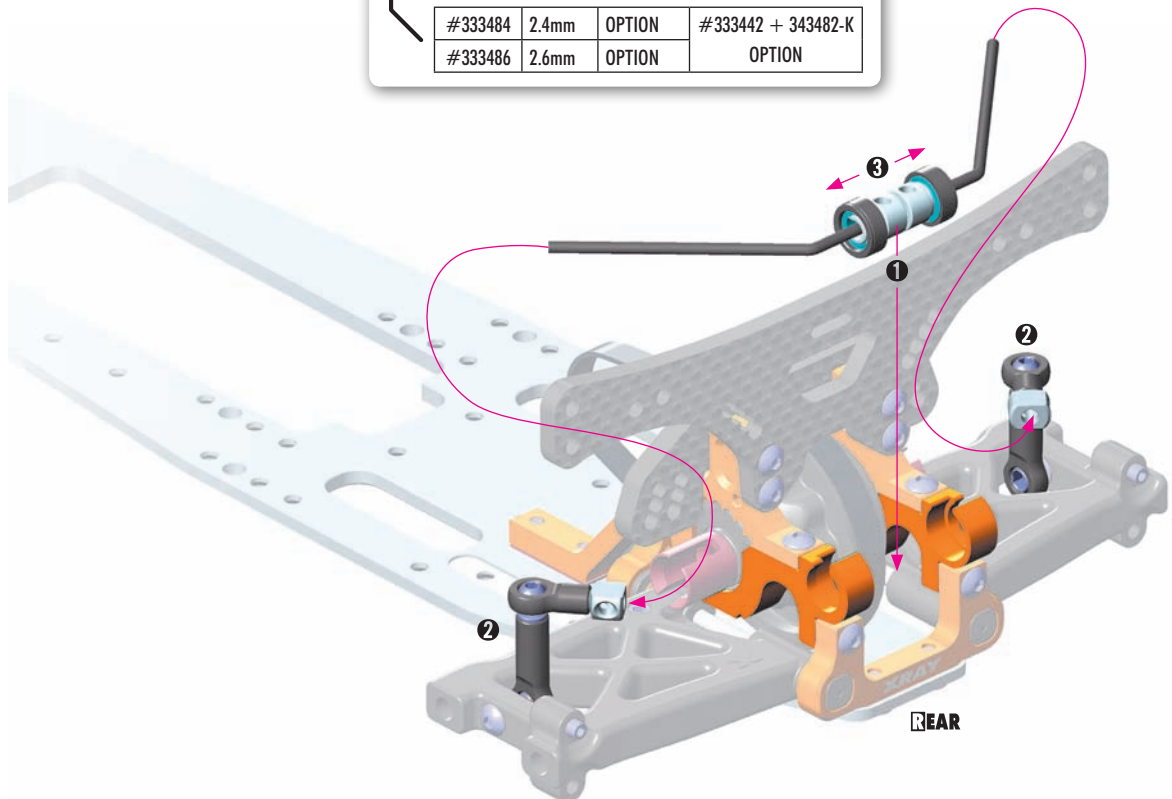

2. REAR SUSPENSION



901302
SB M3x2.5



901303
SB M3x3

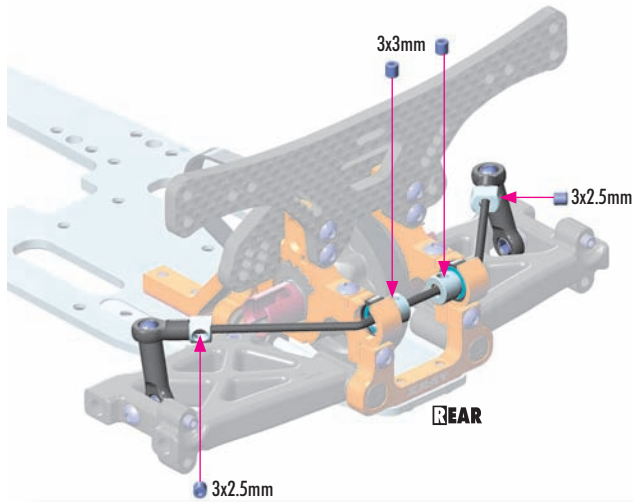

REAR

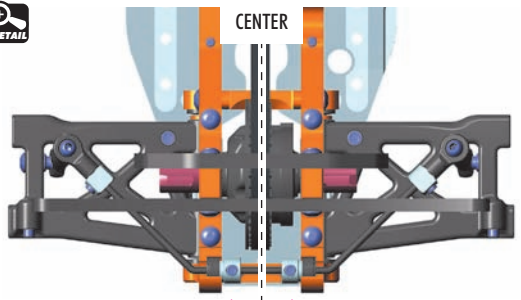

Set the bar into the center, remove the play in the bushings, and tighten the set-screws fully.

TOP VIEW

REAR



REAR ANTI-ROLL BAR
ADJUSTMENT



REAR

When the bars are set, verify that both sides move at the same time. If they do, the bars are set up correctly. If not, make sure that both downstops are the same and that the bar wire is flat.



If the sides still do not move at the same time, adjust the length of the bar holders.

2x

L=R

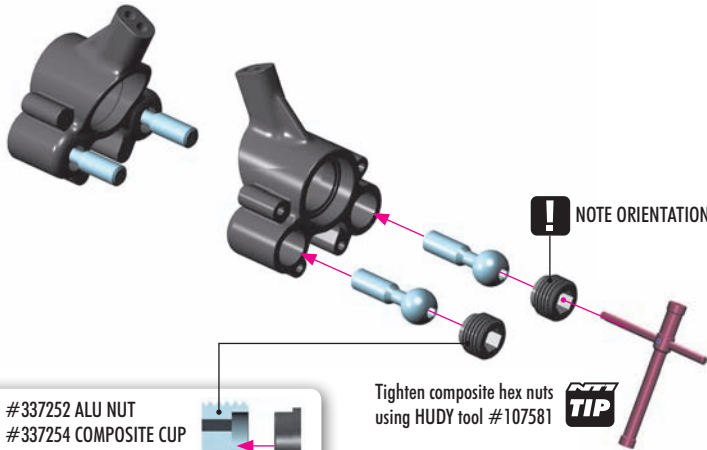

#337252 ALU NUT
#337254 COMPOSITE CUP

Tighten composite hex nuts using HUDY tool #107581



TIP

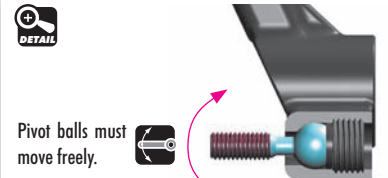

Pivot balls must move freely.

During initial assembly, tighten each composite hex nut until the pivot ball starts to bind, then loosen slightly. Verify that the pivot balls move freely.



OPTION

PIVOT BALLS

#337250	STEEL	INCLUDED	
#337251	ALU	OPTION	
#337255	TITANIUM	OPTION	

2x

L=R

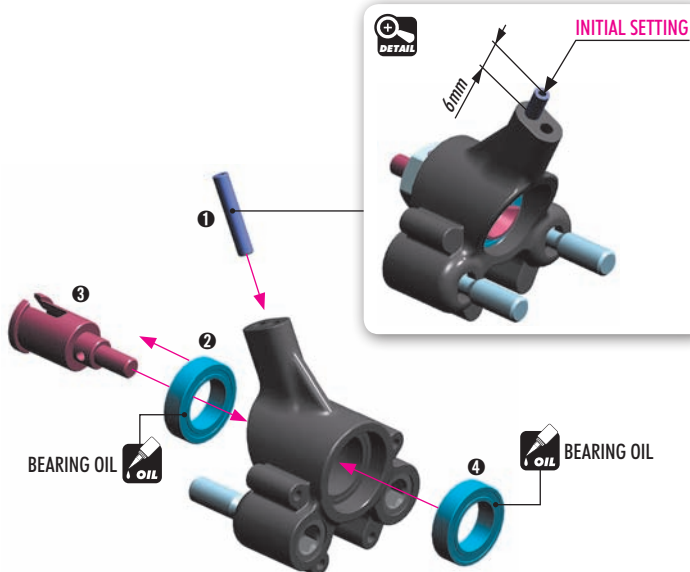

BEARING OIL

BEARING OIL

2x

L=R

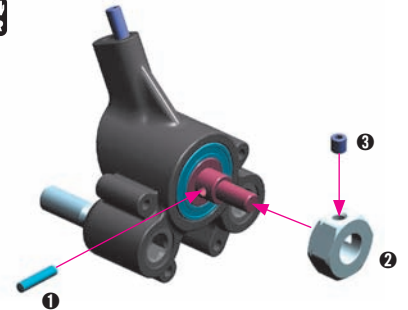

OPTION

WHEEL HUBS

#335250	0mm	INCLUDED	
#335251	-0.75MM	OPTION	
#335252	+0.75MM	OPTION	



901303
SB M3x3



901316
SB M3x16



941016
BB 10x16x4



981210
P 2x10



981210
P 2x10

2. REAR SUSPENSION



303241
BALL 5.8

2x

! Use ball joints WITH DOT



TIP BALL JOINT WRENCH
(HUDY #181110)



L=R 1:1

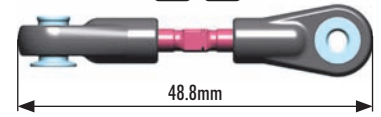

!

90° angle difference between the ball joints

TIP Install the pivot balls with Professional Multi Tool (HUDY #183011)



REAR CAMBER
ADJUSTMENT

2x

L=R

Ensure that both suspension assemblies move freely.

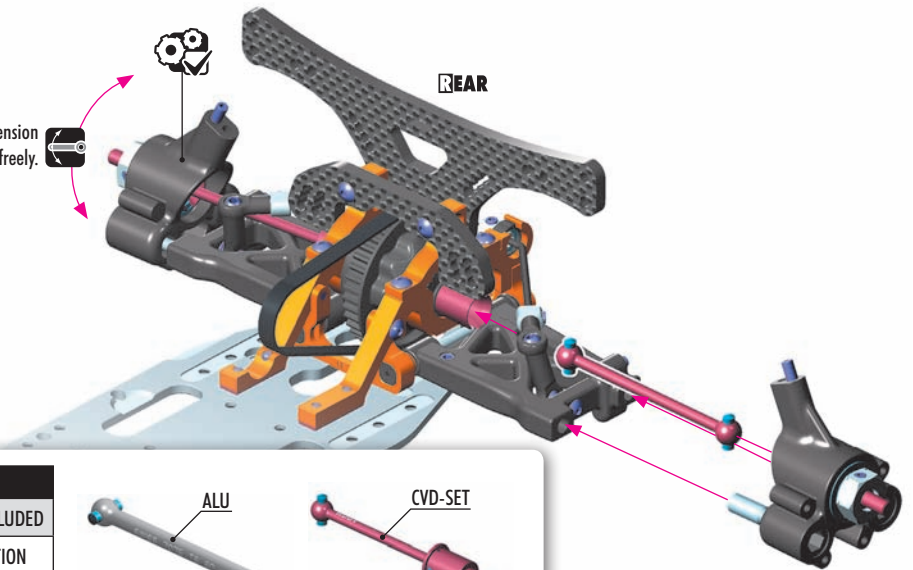

DRIVE SHAFT		
#335320	HUDY SPRING STEEL™	INCLUDED
#335321	ALU	OPTION
#335305	CVD - SET	OPTION

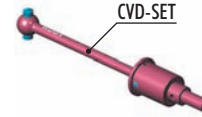
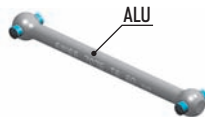

303122-0
SHIM 3x6x1



303123-0
SHIM 3x6x2



902308
SH M3x8

2x

L=R

INSIDE OUTSIDE

L=R ! NOTE ORIENTATION

Ensure that both suspension assemblies move freely.

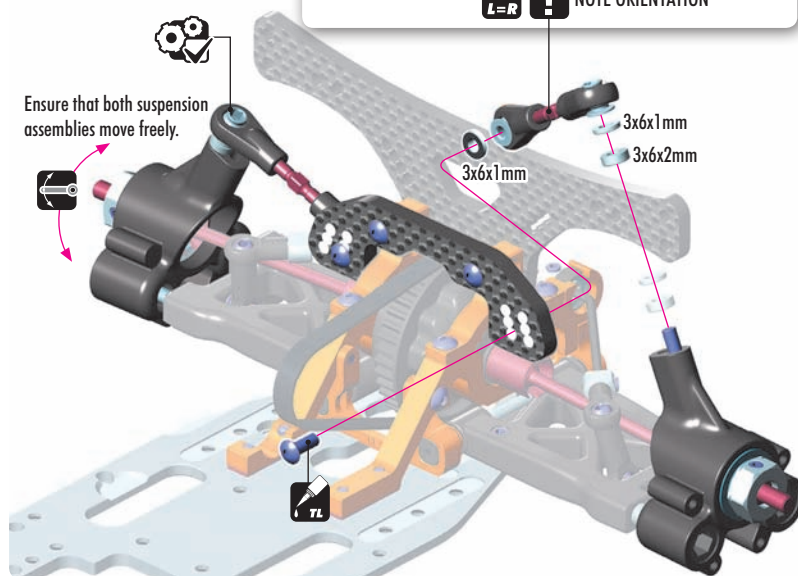

3.2mm 3mm

REAR

FRONT

2. REAR SUSPENSION



296530-0
N M3



303141-0
SHIM 3x5x1



902320
SH M3x20

Roughen steel plates with sandpaper
before gluing SLS pads

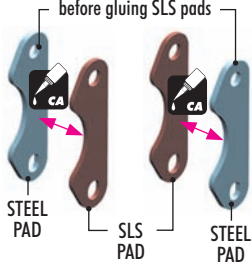

We recommend gluing the brake pads
to the steel pads, however there is no
performance difference between glued
& unglued brake pads.

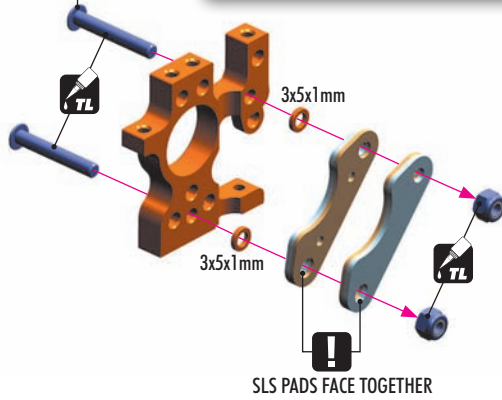
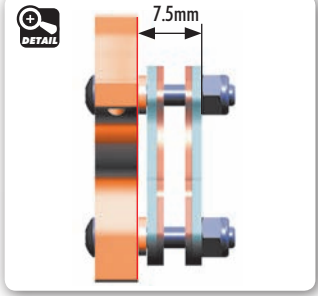
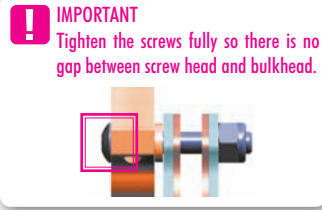
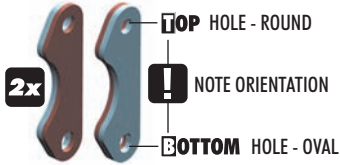

903306
SFH M3x6

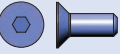

903308
SFH M3x8



940508
BB 5x8x2.5



940613
BB 6x13x5

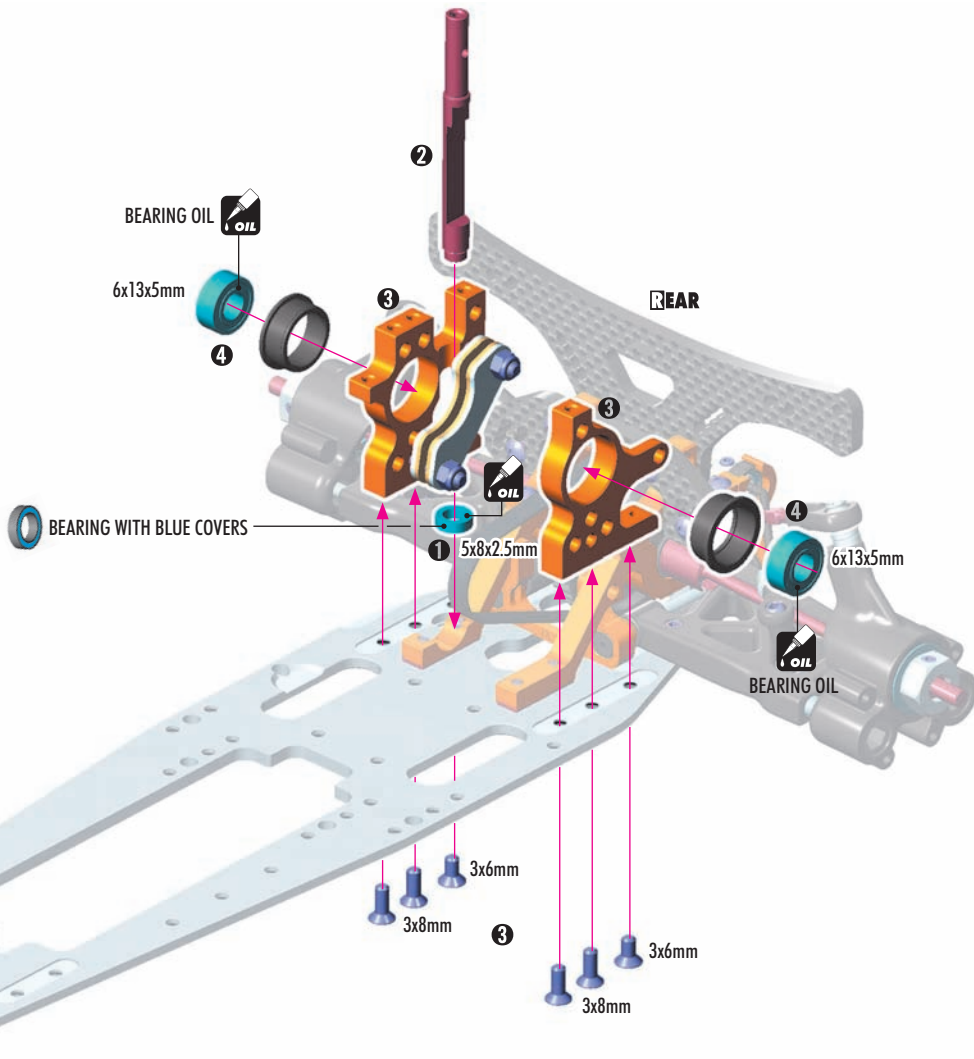

2. REAR SUSPENSION

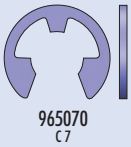

965070
C7

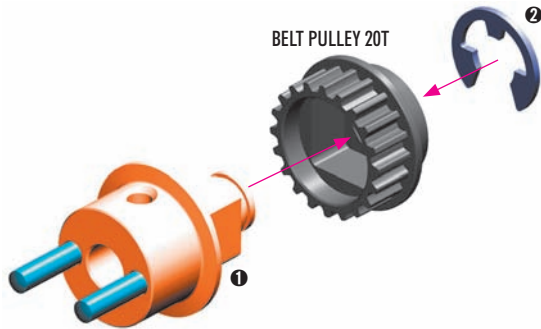

BELT PULLEY 20T



#334141
ALU LIGHTWEIGHT BRAKE DISK ADAPTER - SWISS 7075 T6

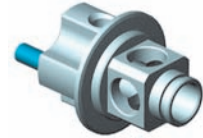

#335801-0
LOW FRICTION COMPOSITE BELT PULLEY SET - GRAPHITE

BELT PULLEY 20T - 2-SPEED CENTER
BELT PULLEY 18T - 2-SPEED SIDE
BELT PULLEY 19T - MID-CENTER
BELT PULLEY 25T - MID-SIDE
BELT PULLEY 26T - MID-SIDE



303130-0
SHIM 3x6x9



902308
SH M3x8



902320
SH M3x20

TIP These screws are part of the
REAR SUSPENSION MULTI-FLEX™ TECHNOLOGY
(see page 20)

! When installing bushings, do the following:

- 1 Remove short screws #902308 connecting bulkheads to RF holder (page 12).
- 2 Insert bushings between bulkheads as shown.
- 3 Install & tighten longer screws #902320.

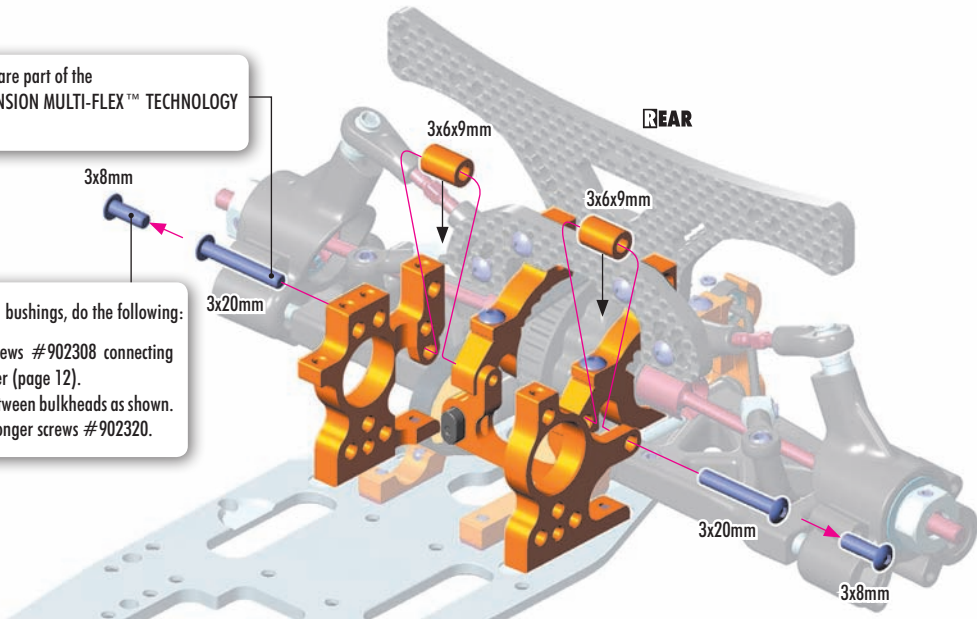

901406
SB M4x6

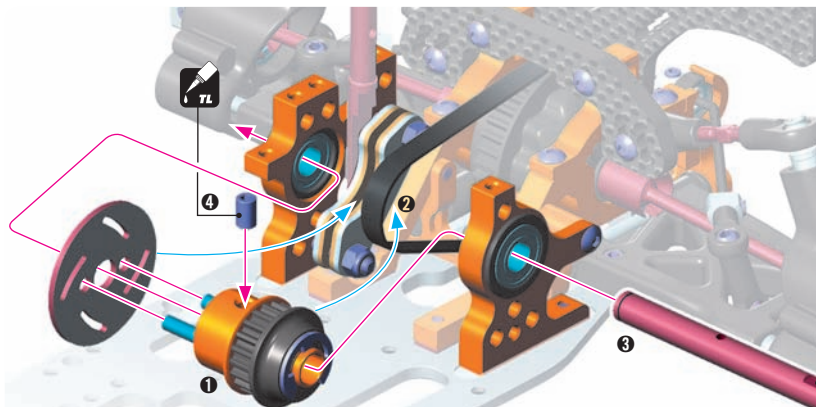

#334111
VENTILATED BRAKE DISC PRECISION-GROUND
LIGHTWEIGHT

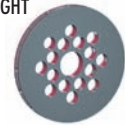

#335511
2-SPEED SHAFT - LIGHTWEIGHT

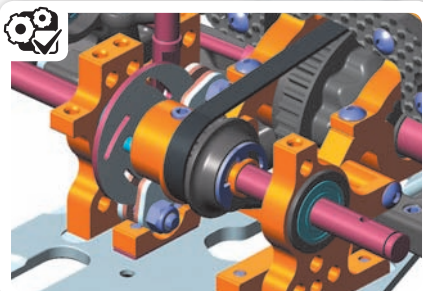

NOTE ORIENTATION

! Tighten set-screw
onto flat spot

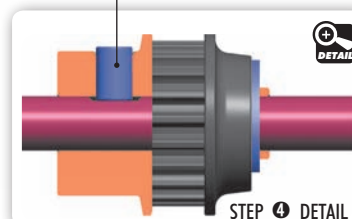

STEP 4 DETAIL

2. REAR SUSPENSION

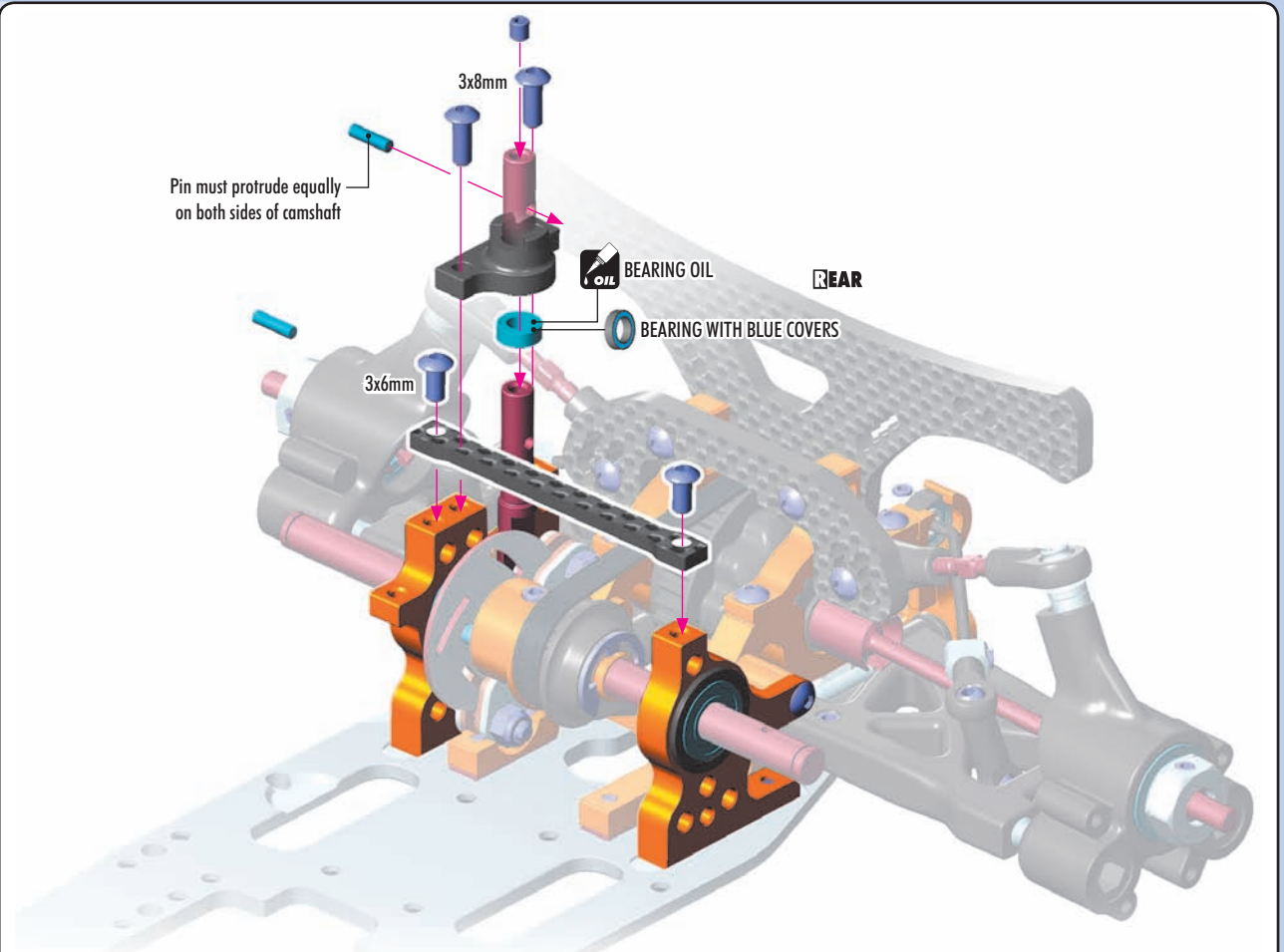

REAR SUSPENSION MULTI-FLEX™ TECHNOLOGY

The all-new rear suspension design features Multi-Flex™ quick adjustment to easily adapt the handling of the car to particular track conditions and tires used. There are 3 different flex characteristics to choose from.

ALTERNATIVE 1 SOFT

Steel spacers and bracket bushings are not used. This allows maximum flex of the rear suspension and generates maximum rear traction. Recommended for low-traction tracks, or races with spec hard or large tires.

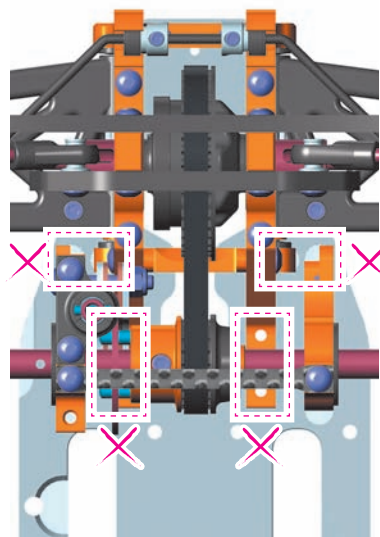

ALTERNATIVE 2 MEDIUM (INITIAL SETTING)

Steel spacers connects the rear bulkheads with chassis, bracket bushings not used. This reduces the flex of the rear suspension and improves out-of-corner steering and rotation of the car, but also slightly decreases rear traction. Recommended for medium-traction tracks, or races with spec softer tires.

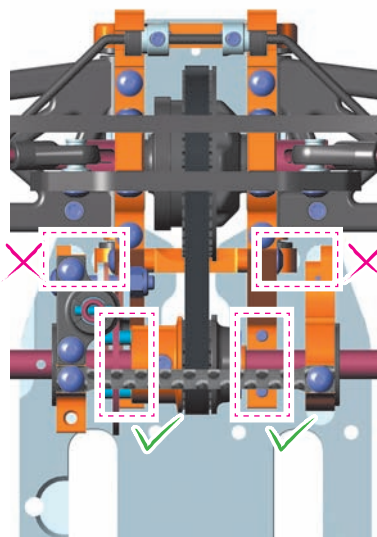

ALTERNATIVE 3 STIFF

Steel spacers connects the rear bulkheads with chassis, bracket bushings are used. This connects the entire rear suspension together, creating a stiff frame which allows the car to rotate more and improves out-of-corner steering. Recommended for high-traction tracks, or when tires with additive are used.

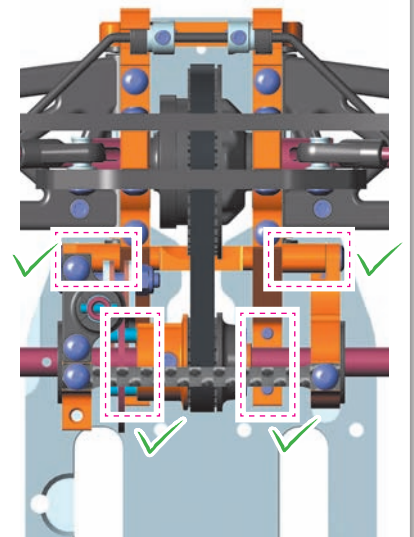

3. REAR TRANSMISSION

#335523
CARRIER FOR 2-SPEED GEAR (2ND) - SWISS 7075 T6 - SOFT
 OPTION

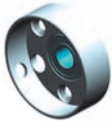

#335531-0
ALU LIGHTWEIGHT DRIVE FLANGE W/ 1-WAY BEARING
 OPTION



GEAR BOX SPRING

OPTION	#	C	
	#335581	C=7.8	OPTION
	#335582	C=10.4	OPTION
	#335583	C=8.5	INCLUDED

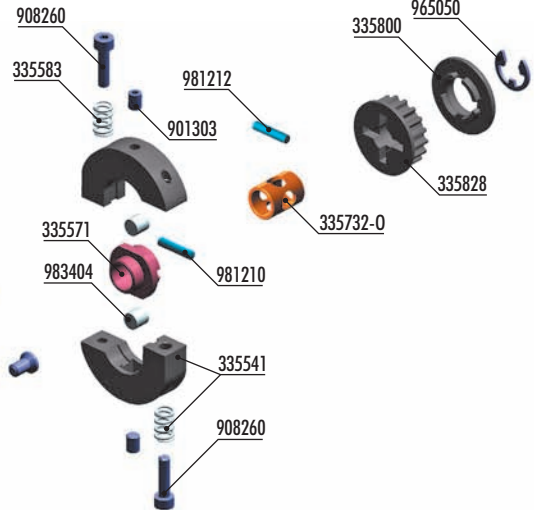
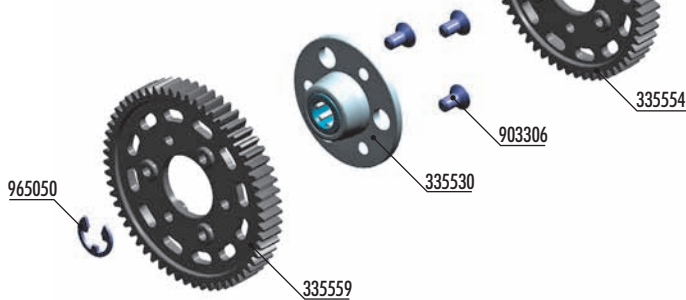

OPTION	COMPOSITE 2-SPEED GEARS				GRAPHITE 2-SPEED GEARS			
	#	T			#	T		
	#335553	53T	2ND	OPTION	#335653	53T	2ND	OPTION
	#335554	54T	2ND	INCLUDED	#335654	54T	2ND	OPTION
	#335555	55T	2ND	OPTION	#335655	55T	2ND	OPTION
	#335557	57T	1ST	OPTION	#335657	57T	1ST	OPTION
	#335558	58T	1ST	OPTION	#335658	58T	1ST	OPTION
	#335559	59T	1ST	INCLUDED	#335659	59T	1ST	OPTION
	#335560	60T	1ST	OPTION	#335660	60T	1ST	OPTION

BAG
03

- 335522 ALU SMALL CARRIER FOR 2-SPEED GEAR (2nd) + BALL-BEARING - ALU 7075 T6
- 335530 DRIVE FLANGE WITH ONE-WAY BEARING - ALU 7075 T6
- 335541 COMPOSITE SMALL 2-SPEED GEAR BOX SHOE - SET
- 335554 COMPOSITE 2-SPEED GEAR 54T (2nd) - V3
- 335559 COMPOSITE 2-SPEED GEAR 59T (1st)
- 335571 ADAPTER SMALL 2-SPEED
- 335590 HEX SCREW SFH M3x6 - GRINDED (3)
- 335583 SPRING FOR SMALL GEAR BOX - MEDIUM-HARD (2)
- 335732-0 ALU LIGHTWEIGHT LOCATING COLLAR - ORANGE (2)
- 335800 COMPOSITE BELT PULLEY COVER SET

- 335828 COMPOSITE BELT PULLEY 18T - 2-SPEED-SIDE
- 901303 HEX SCREW SB M3x3 (10)
- 903306 HEX SCREW SFH M3x6 (10)
- 908260 HEX SCREW SOCKET HEAD CAP M2.5x10 (10)
- 965050 E-CLIP 5 (10)
- 981210 PIN 2x10 (10)
- 981212 PIN 2x12 (10)
- 983404 ROLLER PIN 4x4 MM (2)

965050
 C5

981212
 P 2x12

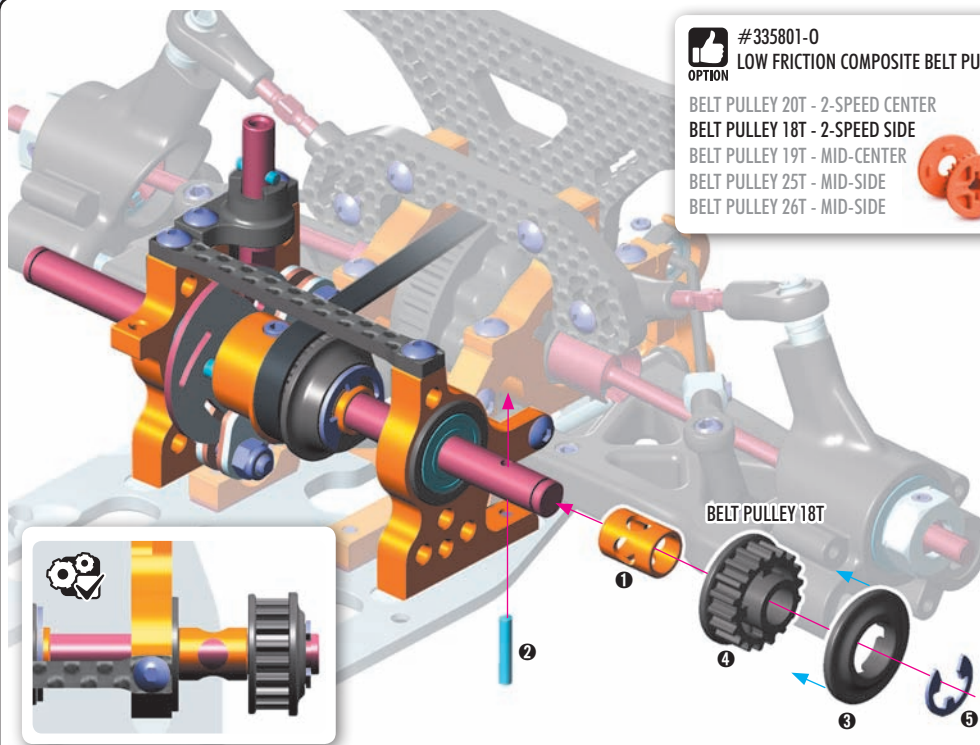

#335801-0
LOW FRICTION COMPOSITE BELT PULLEY SET - GRAPHITE
 OPTION

- BELT PULLEY 20T - 2-SPEED CENTER
- BELT PULLEY 18T - 2-SPEED SIDE
- BELT PULLEY 19T - MID-CENTER
- BELT PULLEY 25T - MID-SIDE
- BELT PULLEY 26T - MID-SIDE

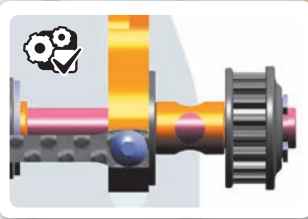

3. REAR TRANSMISSION



901303
SB M3x3

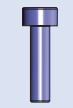

908260
SCH M2.5x10



983404
RP 4x4

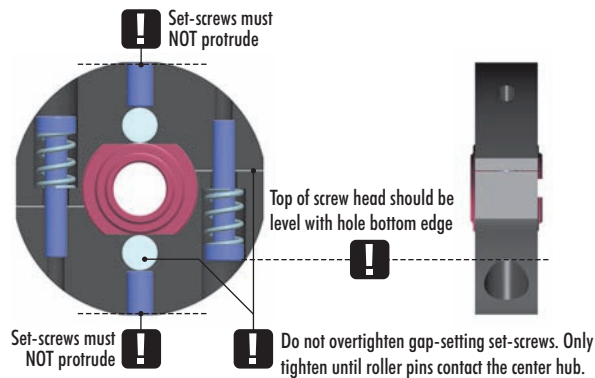
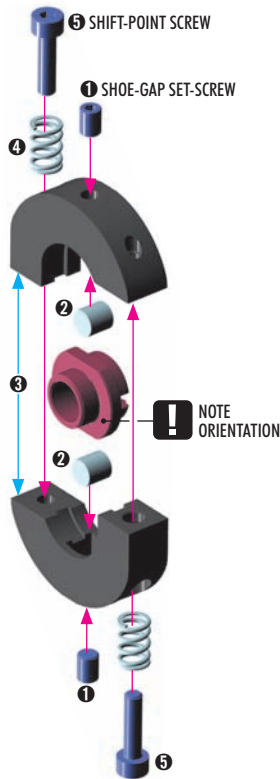

OPTION

GEAR BOX SPRING

#335581	C=7.8	OPTION
#335582	C=10.4	OPTION
#335583	C=8.5	INCLUDED



335590
SFH M3x6
GROUND



903306
SFH M3x6

TIP Use HUDY Reamer #107600 to slightly chamfer the edges on all 3 holes for screws

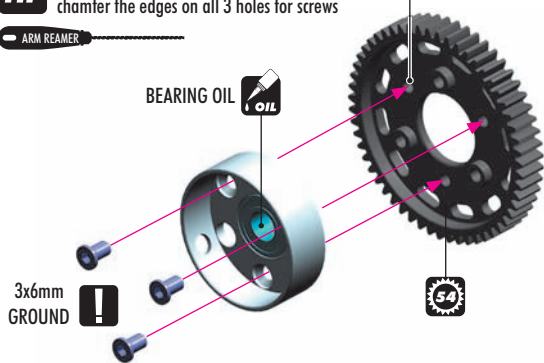

#335523
OPTION
CARRIER FOR 2-SPEED GEAR (2ND) - SWISS 7075 T6 - SOFT



Softer material results in more consistent clutch engagement.



TIP Use HUDY Reamer #107600 to slightly chamfer the edges on all 3 holes for screws



NOTE ORIENTATION

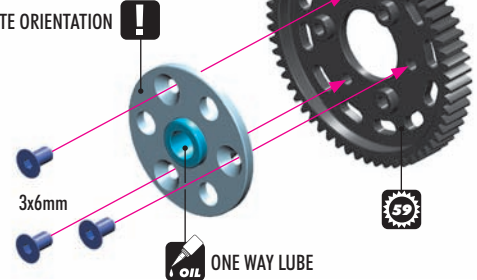

#335531-0
OPTION
ALU LIGHTWEIGHT DRIVE FLANGE
W/ 1-WAY BEARING - ORANGE



965050
CS



981210
P 2x10

IMPORTANT!

Adjust the shoe gap according to the Set-Up Book

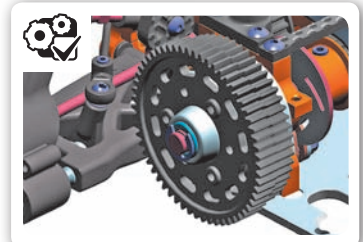
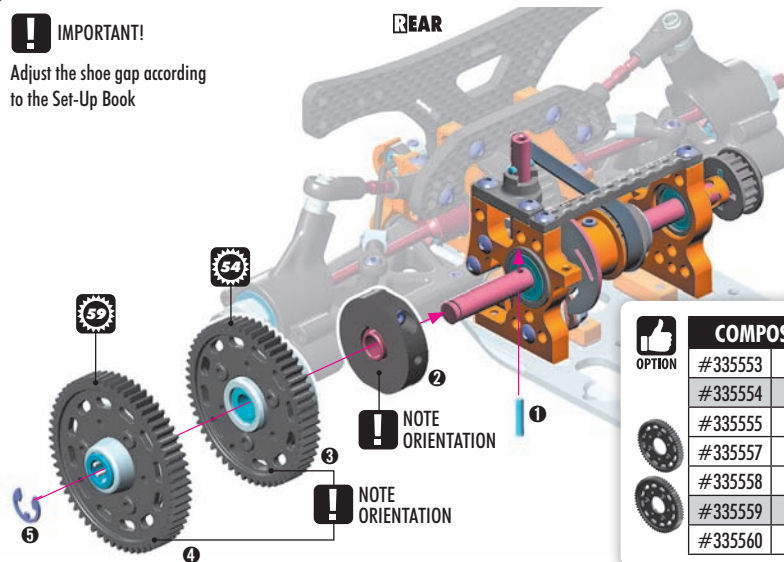

OPTION

COMPOSITE 2-SPEED GEARS

#335553	53T	2ND	OPTION
#335554	54T	2ND	INCLUDED
#335555	55T	2ND	OPTION
#335557	57T	1ST	OPTION
#335558	58T	1ST	OPTION
#335559	59T	1ST	INCLUDED
#335560	60T	1ST	OPTION

GRAPHITE 2-SPEED GEARS

#335653	53T	2ND	OPTION
#335654	54T	2ND	OPTION
#335655	55T	2ND	OPTION
#335657	57T	1ST	OPTION
#335658	58T	1ST	OPTION
#335659	59T	1ST	OPTION
#335660	60T	1ST	OPTION



TRANSMISSION
ADJUSTMENT

4. FRONT SUSPENSION

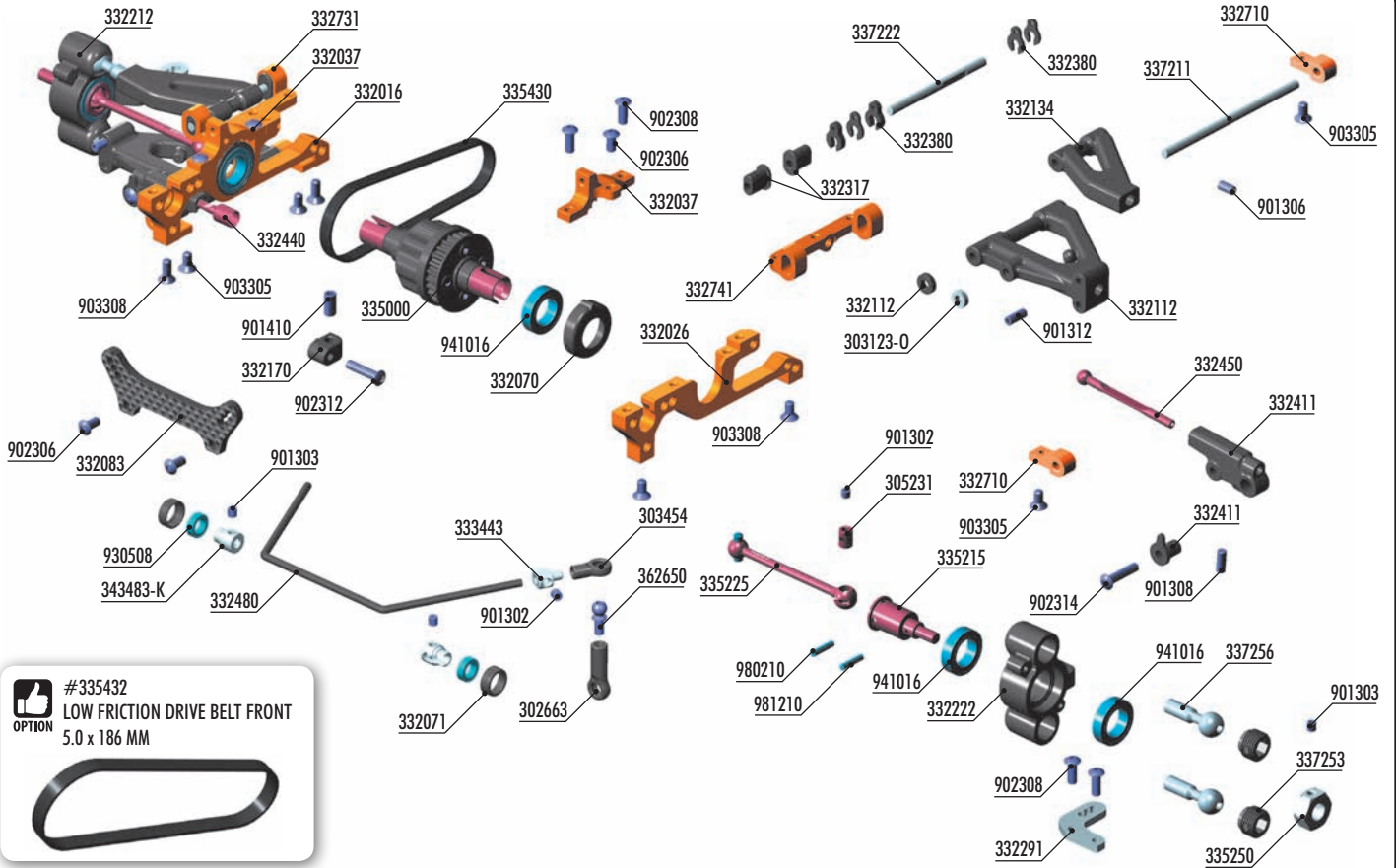

BAG

04

- | | | | |
|----------|---|----------|--|
| 302663 | COMPOSITE BALL JOINT 4.9MM - OPEN - V2 (8) | 335215 | CVD AXLE - SUPER LIGHT - HUDY SPRING STEEL™ |
| 303123-0 | ALU SHIM 3x6x2.0MM - ORANGE (10) | 335225 | CVD DRIVE SHAFT - FRONT - HUDY SPRING STEEL™ |
| 303454 | BALL JOINT 4.9MM - OPEN (4) | 335250 | ALU WHEEL HUB 12MM - BLACK (2) |
| 305231 | DRIVE SHAFT COUPLING - HUDY SPRING STEEL™ | 335430 | PUR®-REINFORCED DRIVE BELT FRONT 5 x 186 MM |
| 332016 | ALU LOWER BULKHEAD FRONT RIGHT - SWISS 7075 T6 | 337211 | FRONT LOWER INNER PIVOT PIN (2) |
| 332026 | ALU LOWER BULKHEAD FRONT LEFT - SWISS 7075 T6 | 337222 | FRONT UPPER PIVOT PIN WITH FLAT SPOT (2) |
| 332037 | ALU UPPER CLAMP FRONT (L+R) - SWISS 7075 T6 | 337253 | COMPOSITE ADJUSTING NUT M10x1 WITH BALL CUP (4) |
| 332070 | COMPOSITE ADJUST. BALL-BEARING HUB (4) | 337256 | STEEL PIVOT BALL 8.4 MM (2) |
| 332071 | COMPOSITE BALL-BEARING HUB (4) | 343483-K | ALU CUTTED ANTI-ROLL BAR COLLAR ø2.3 - BLACK (2) |
| 332083 | GRAPHITE SHOCK TOWER FRONT 2.5MM | 362650 | BALL END 4.9MM WITH THREAD 6MM (2) |
| 332112 | COMPOSITE SUSP. ARM FRONT LOWER FOR WIRE ANTI-ROLL BAR | 901302 | HEX SCREW SB M3x2.5 (10) |
| 332134 | COMPOSITE SUSP. ARM FRONT UPPER WITH HOLE - SOFT | 901303 | HEX SCREW SB M3x3 (10) |
| 332170 | COMPOSITE SUSP. ARM BACKSTOP (2) | 901306 | HEX SCREW SB M3x6 (10) |
| 332212 | COMPOSITE STEERING BLOCK RIGHT FOR AERO DISC | 901308 | HEX SCREW SB M3x8 (10) |
| 332222 | COMPOSITE STEERING BLOCK LEFT FOR AERO DISC | 901312 | HEX SCREW SB M3x12 (10) |
| 332291 | ALU EXTENSION FOR STEERING BLOCK - SWISS 7075 T6 (2) | 901410 | HEX SCREW SB M4x10 (10) |
| 332317 | COMPOSITE SUSP. ECCENTRIC BUSHING (2+2) | 902306 | HEX SCREW SH M3x6 (10) |
| 332380 | COMPOSITE CASTER CLIPS (2) | 902308 | HEX SCREW SH M3x8 (10) |
| 332411 | COMPOSITE FRONT ANTI-ROLL BAR HOLDER & ECCENTRIC W/O UPSTOP (2+2) | 902312 | HEX SCREW SH M3x12 (10) |
| 332440 | ANTI-ROLL BAR FRONT FEMALE - HUDY SPRING STEEL™ | 902314 | HEX SCREW SH M3x14 (10) |
| 332450 | ANTI-ROLL BAR FRONT MALE - HUDY SPRING STEEL™ | 903305 | HEX SCREW SFH M3x5 (10) |
| 332480 | ANTI-ROLL BAR FRONT 2.0 MM | 903308 | HEX SCREW SFH M3x8 (10) |
| 332710 | ALU LOWER 2-PIECE FRONT SUSPENSION HOLDER (1) | 930508 | BALL-BEARING 5x8x2.5 (2) |
| 332731 | ALU UPPER ARM HOLDER RIGHT - SWISS 7075 T6 - SET | 941016 | BALL-BEARING 10x16x4 RUBBER SEALED - OIL (2) |
| 332741 | ALU UPPER ARM HOLDER LEFT - SWISS 7075 T6 - SET | 980210 | PIN 2x10 (10) |
| 333443 | ALU ANTI-ROLL BAR COLLAR ø2.2 (2) | 981210 | PIN 2x10 (10) |
| 335000 | FRONT GEAR DIFFERENTIAL - SET | | |

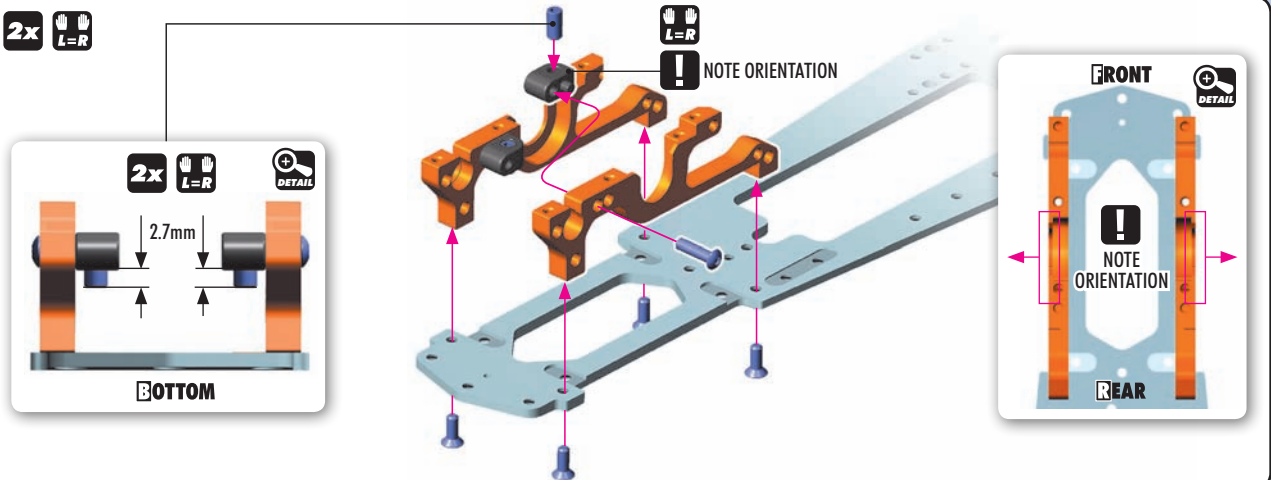
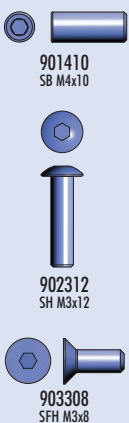

4. FRONT SUSPENSION

The NT1 kit comes with both types of front anti-roll bars, blade-style or wire. Decide which anti-roll bar to use.

Blade anti-roll bar (Alternative 1) page 24 is recommended for long, fast tracks when maximum cornering speed is needed. With the blade anti-roll bar, the car will not dive in the corners and will maintain maximum speed. Follow the "Alternative 1" assembly steps described immediately below.

Wire anti-roll bar (Alternative 2) go to page 28 is recommended for smaller, technical tracks when fast direction changes and side weight changes are needed. Follow the "Alternative 2" assembly steps starting on page 28; DO NOT assemble the blade bar as described immediately below.

ALTERNATIVE 1 (BLADE ANTI-ROLL BAR)

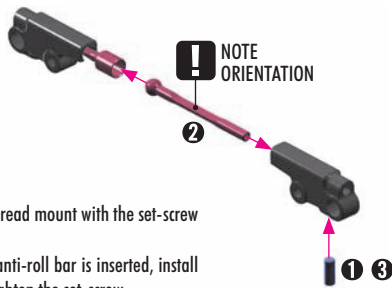

FRONT BLADE ANTI-ROLL BARS		
#332440	FEMALE 1.0MM	INCLUDED
#332441	FEMALE 0.7MM	OPTION
#332450	MALE 1.0MM	INCLUDED
#332451	MALE 0.7MM	OPTION



#332401-0
DOWNSTOP INDEPENDENT ALU
FRONT ANTI-ROLL BAR - ORANGE



902314
SH M3x14



903305
SFH M3x5



Forward Arm Position (A)
Shim **BEHIND** arm

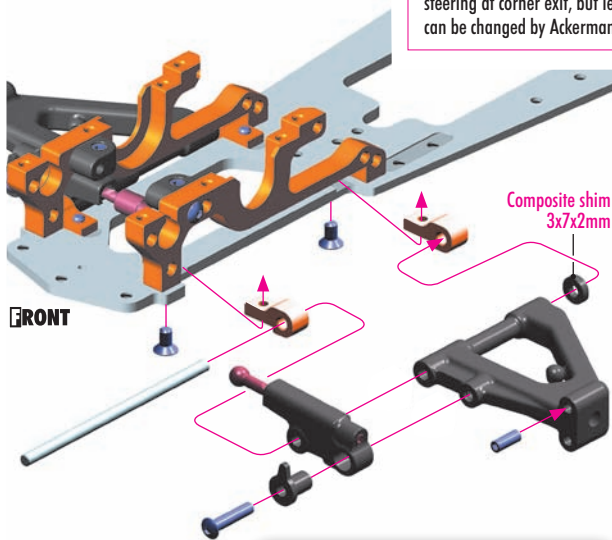

IMPORTANT!

The position of the front arm directly influences the steering Ackermann (angle of the steering linkages). When the arm is moved to rearward position (shim in front of the arm), the angle of the steering linkages changes and gives less Ackermann. By decreasing the Ackermann, the car gets more turn-in & increased steering at corner exit, but less cornering speed. The Ackermann can be changed by Ackermann inserts (see page 34, step 1).



Rearward Arm Position (B)
(INITIAL SETTING)
Shim **IN FRONT OF** arm

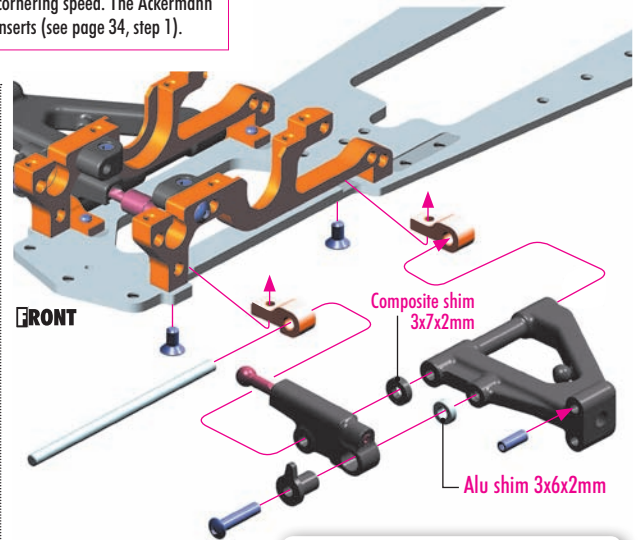

Each anti-roll bar blade has a hex hole at its end. Use a 1.5mm hex wrench to adjust the blades.

1.5mm



Do not insert ball into cup too deeply or bars will bind during operation

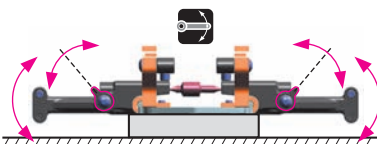

Ensure that the suspension arms move freely. Ensure that the eccentric holders move freely.

When the bar is set, verify that both sides move at the same time. If they do, the bars are set up correctly. If not, make sure that both downstops are the same. If the arms still do not move at the same time, gently loosen the screw which holds eccentric bushing and rotate the bushing until the arms move at the same time. Retighten the screws fully.



FRONT SUSPENSION ARMS		
#332112	MEDIUM	INCLUDED
#332113	HARD	OPTION



SET-UP BOOK
FRONT ANTI-ROLL BAR
ADJUSTMENT
DOWNSTOP ADJUSTMENT

4. FRONT SUSPENSION

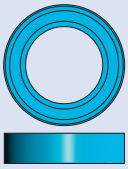

941016
BB 10x16x4

NOTE ORIENTATION
Both bushings must be in same position

NOTE ORIENTATION

NOTE ORIENTATION
Both bushings must be in same position

BEARING OIL

BEARING OIL

OPTION #335432
LOW FRICTION DRIVE BELT FRONT
5.0 x 186 MM

FRONT



902308
SH M3x8

2x **L=R**

FRONT BELT TENSION ADJUSTMENT

FRONT **REAR**

INITIAL POSITION

TO TIGHTEN FRONT BELT: Rotate both front nylon hubs in arrow direction **B**

TO LOOSEN FRONT BELT: Rotate both front nylon hubs in arrow direction **A**

RIGHT **LEFT**

FRONT

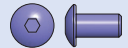

902306
SH M3x6

2x **L=R**

Do not tighten fully.
This screw will be tightened after
assembling the radio plate (see page 37).

NOTE ORIENTATION

FRONT

4. FRONT SUSPENSION

901306
SB M3x6

2x L=R



FRONT UPPER ARMS			
#332134	SOFT	INCLUDED	
#332133	HARD	OPTION	
#332132	MEDIUM	OPTION	

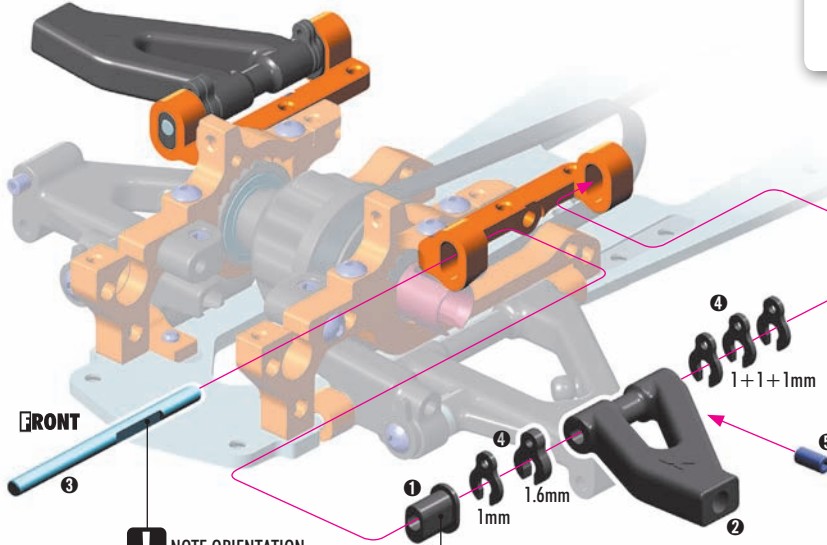

NOTE ORIENTATION

STEP 5 DETAIL



Use (+0.5mm) suspension holders for initial assembly

FRONT ROLL CENTER INSERT POSITIONS

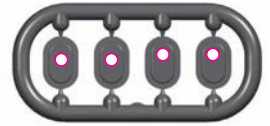

INITIAL SETTING



902306
SH M3x6

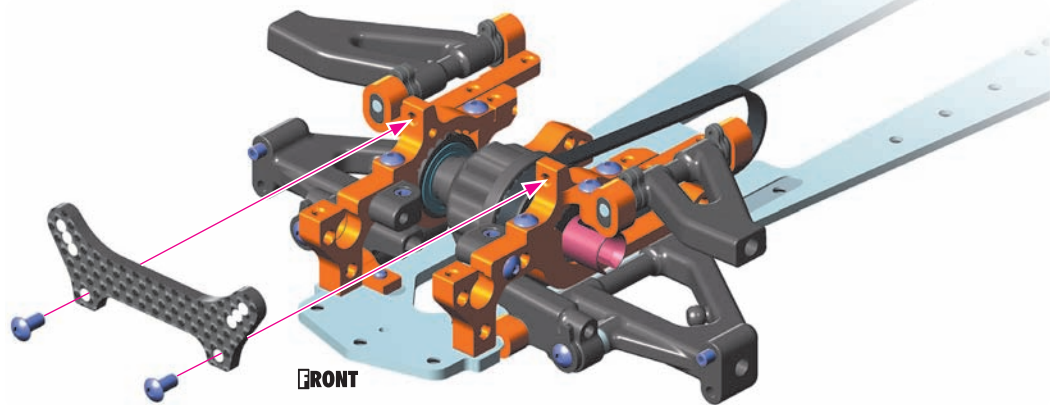

FRONT

2x L=R

NOTE ORIENTATION

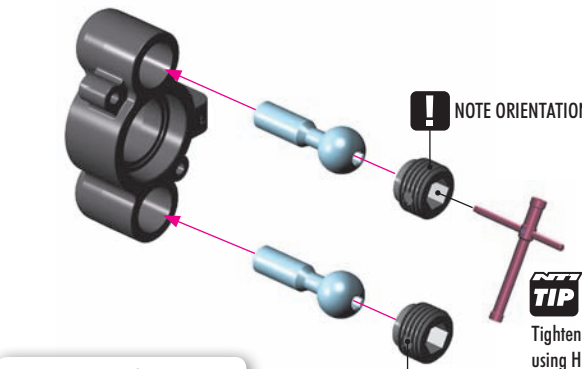

#337252 Alu nut
#337254 Composite cup

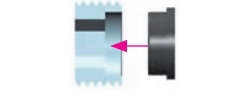

TIP
Tighten composite hex nuts using HUDY tool #107581

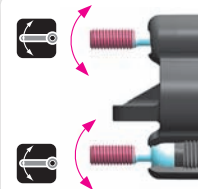

Pivot balls must move freely. During initial assembly, tighten each composite hex nut until the pivot ball starts to bind, then loosen slightly. Verify that the pivot balls move freely.



STEERING BLOCK			
#332212	0°	RIGHT	INCLUDED
#332213	1°	RIGHT	OPTION
#332222	0°	LEFT	INCLUDED
#332223	1°	LEFT	OPTION



PIVOT BALLS		
#337256	STEEL	INCLUDED
#337251	ALU	OPTION
#337255	TITANIUM	OPTION



4. FRONT SUSPENSION



902308
SH M3x8

2x L=R

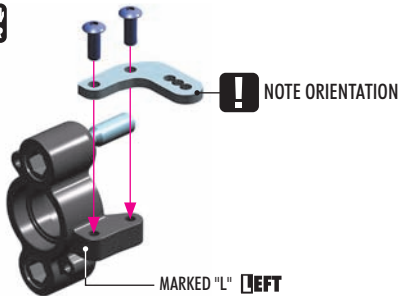

OPTION #332290 GRAPHITE EXTENSION FOR STEERING BLOCK (2)



Optional graphite steering arms are available. They give more flex and front traction, but they are more fragile.



901302
SB M3x2.5

980210
P 2x10

2x L=R

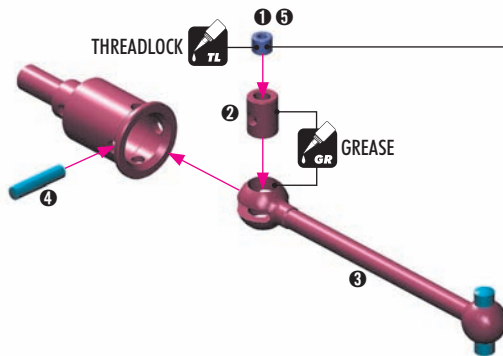

STEP 3 DETAIL
Tighten the screw fully when the pin is installed



941016
BB 10x16x4

2x L=R

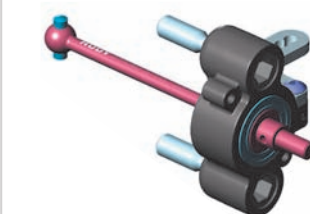
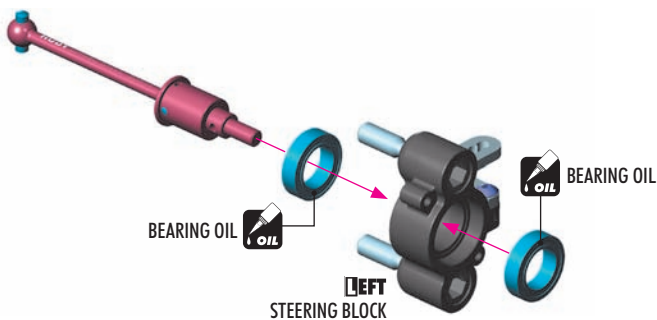

901303
SB M3x3

981210
P 2x10

2x L=R

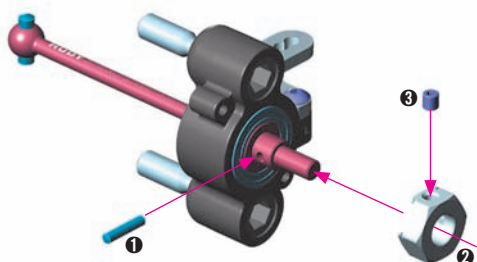

WHEEL HUBS

OPTION	WHEEL HUBS	INCLUDED	
#335250	0.0mm	INCLUDED	
#335251	-0.75mm	OPTION	
#335252	+0.75mm	OPTION	

2x L=R

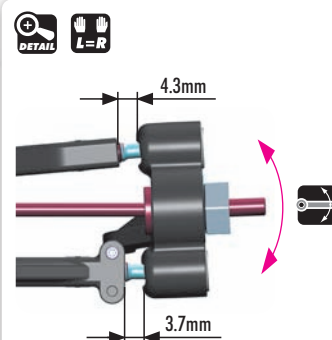
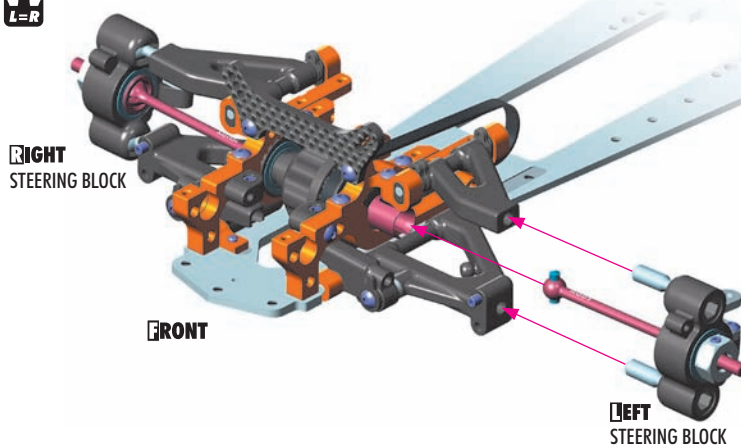

Ensure that the front suspension moves freely



4. FRONT SUSPENSION

ALTERNATIVE 2 (WIRE ANTI-ROLL BAR)

901308
SB M3x8

2x

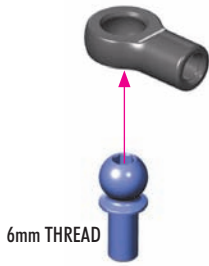

6mm THREAD

TIP Install the pivot balls with Professional Multi Tool (HUDY #183011)



2x

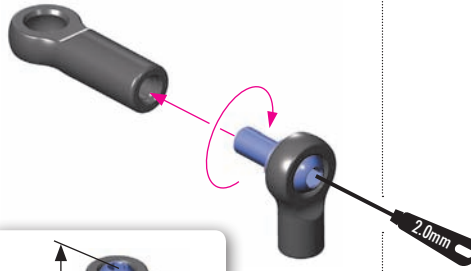

26mm

DETAIL

2x

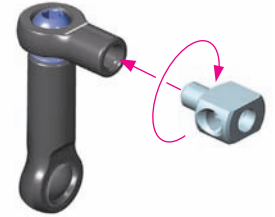

303123-0
SHIM 3x7x2

332112
SHIM 3x7x2

902314
SH M3x14

902314

903305
SFH M3x5

903305

901312
SB M3x12

901312

Forward Arm Position (A)
Shim **BEHIND** arm

IMPORTANT!

The position of the front arm directly influences the steering Ackermann (angle of the steering linkages). When the arm is moved to rearward position (shim in front of the arm), the angle of the steering linkages changes and gives less Ackermann. By decreasing the Ackermann, the car gets more turn-in & increased steering at corner exit, but less cornering speed. The Ackermann can be changed by Ackermann inserts (see page 34, step 1).

Rearward Arm Position (B)
(INITIAL SETTING)
Shim **IN FRONT** of arm

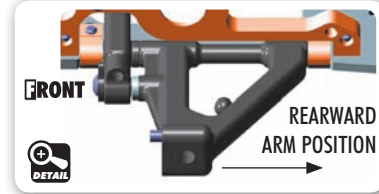
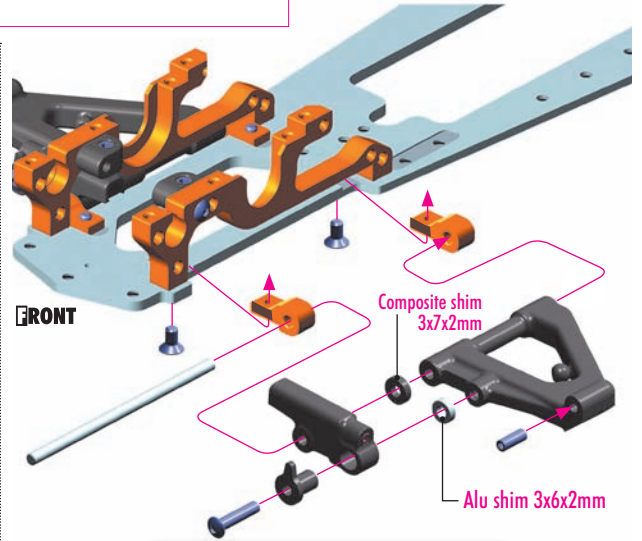
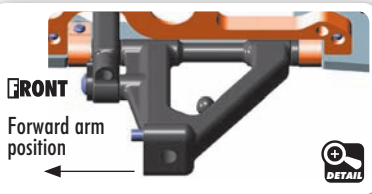
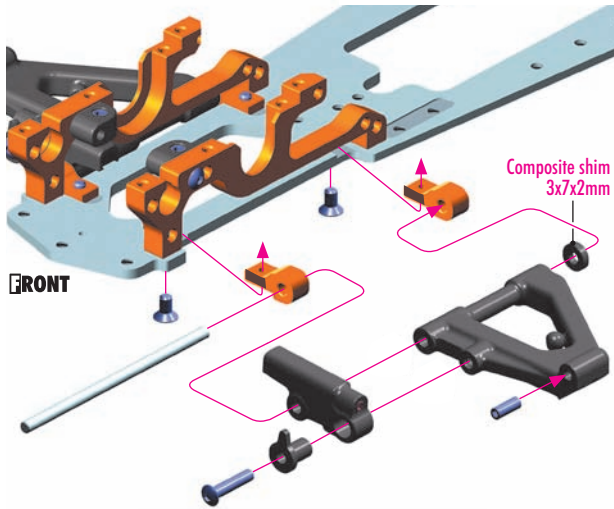

930508
BB 5x8x2.5



OPTION	FRONT ANTI-ROLL BARS		COLLARS
#332479	1.8mm	OPTION	#333443 + 343483-K
#332480	2.0mm	INCLUDED	INCLUDED
#332482	2.2mm	OPTION	INCLUDED
#332484	2.4mm	OPTION	#333442 + 343482-K
#332486	2.6mm	OPTION	OPTION
#332488	2.8mm	OPTION	#333441 + 343481-K
			OPTION

4. FRONT SUSPENSION

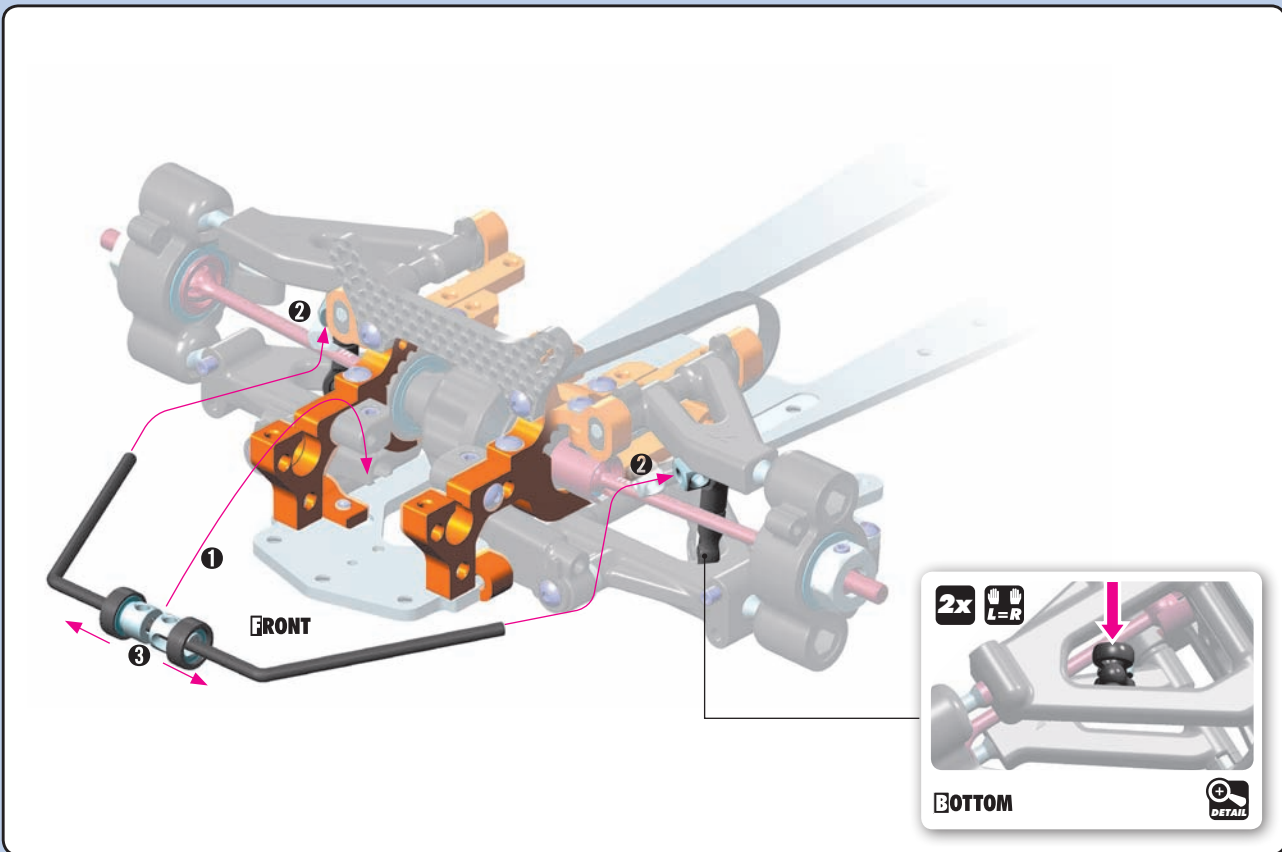

- 901302
SB M3x2.5
- 901303
SB M3x3

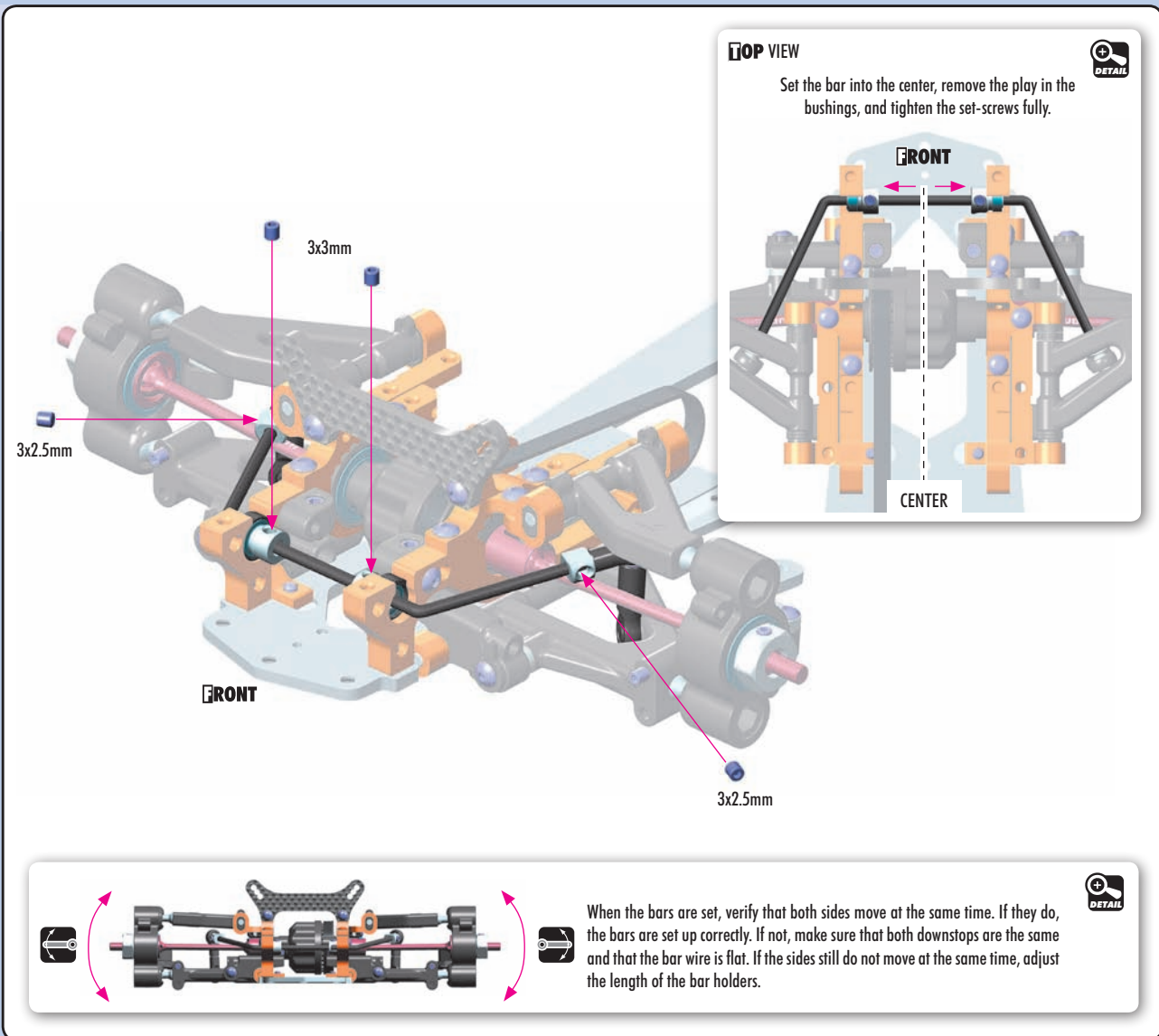

5. FRONT TRANSMISSION



#335443
LOW FRICTION DRIVE BELT SIDE 4.5 X 396 MM

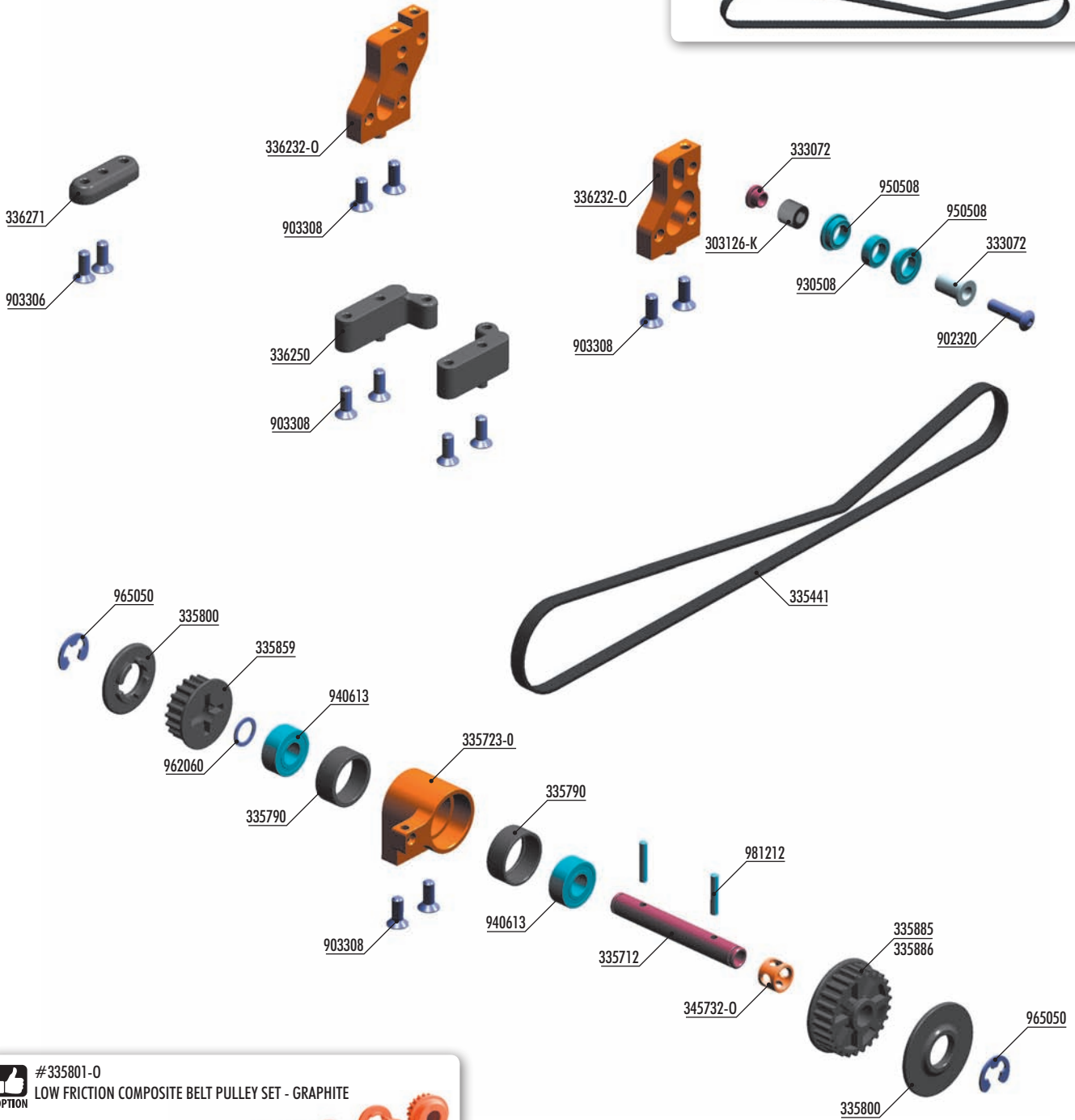

#335801-0
LOW FRICTION COMPOSITE BELT PULLEY SET - GRAPHITE

BELT PULLEY 20T - 2-SPEED CENTER
BELT PULLEY 18T - 2-SPEED SIDE
BELT PULLEY 19T - MID-CENTER
BELT PULLEY 25T - MID-SIDE
BELT PULLEY 26T - MID-SIDE



BAG

05

303126-K	ALU SHIM 3x6x5.0MM - BLACK (10)	336271	COMPOSITE BATTERY PLATE HOLDER
333072	BELT TENSIONER SET	345732-0	ALU MIDDLE SHAFT LOCATING COLLAR - SHORT - LIGHTWEIGHT - ORANGE
335441	PUR®-REINFORCED DRIVE BELT SIDE 4.5 x 390 MM	902320	HEX SCREW SH M3x20 (10)
335712	FRONT MIDDLE SHAFT - HUDY SPRING STEEL™ - LIGHTWEIGHT	903306	HEX SCREW SFH M3x6 (10)
335723-0	ALU FRONT MIDDLE SHAFT HOLDER - ORANGE	903308	HEX SCREW SFH M3x8 (10)
335790	COMPOSITE BALL-BEARING BUSHING FOR MIDDLE SHAFT (2)	930508	BALL-BEARING 5x8x2.5 STEEL SEALED - OIL (2)
335800	COMPOSITE BELT PULLEY COVER SET	940613	BALL-BEARING 6x13x5 RUBBER SEALED - OIL (2)
335859	COMPOSITE BELT PULLEY 19T - MID-CENTER	950508	BALL-BEARING 5x8x2.5 FLANGED - STEEL SEALED - OIL (2)
335885	COMPOSITE BELT PULLEY 25T - MID-SIDE	962060	WASHER S 6x8x0.5 (10)
335886	COMPOSITE BELT PULLEY 26T - MID-SIDE	965050	E-CLIP 5 (10)
336232-0	ALU RADIO PLATE MOUNTS (L + R) - SWISS 7075 T6 - ORANGE	981212	PIN 2x12 (10)
336250	COMPOSITE BATTERY MOUNT L+R (2)		

5. FRONT TRANSMISSION



940613
BB 6x13x5

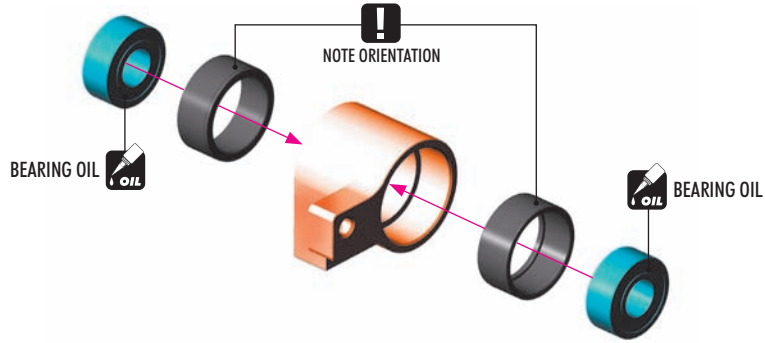

962060
SHIM 6x8x0.5



965050
C5

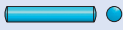

981212
P 2x12

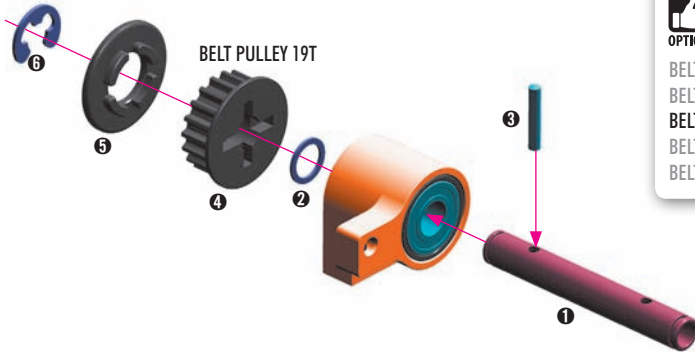

#335801-0

OPTION

LOW FRICTION COMPOSITE BELT PULLEY SET - GRAPHITE

BELT PULLEY 20T - 2-SPEED CENTER

BELT PULLEY 18T - 2-SPEED SIDE

BELT PULLEY 19T - MID-CENTER

BELT PULLEY 25T - MID-SIDE

BELT PULLEY 26T - MID-SIDE

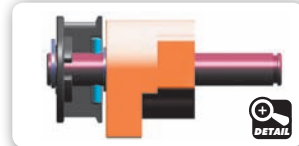

965050
C5



981212
P 2x12

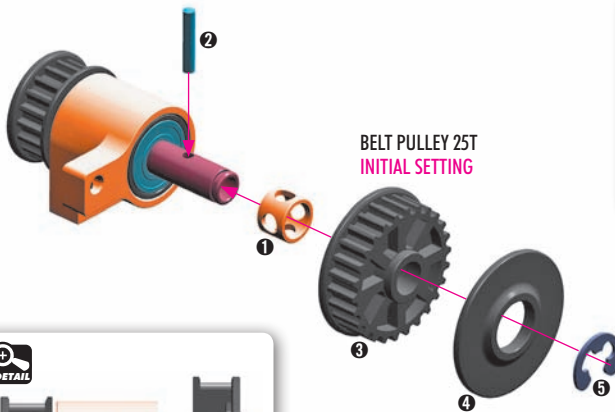

#335801-0

OPTION

LOW FRICTION COMPOSITE BELT PULLEY SET - GRAPHITE

BELT PULLEY 20T - 2-SPEED CENTER

BELT PULLEY 18T - 2-SPEED SIDE

BELT PULLEY 19T - MID-CENTER

BELT PULLEY 25T - MID-SIDE

BELT PULLEY 26T - MID-SIDE

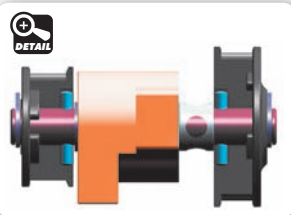

#335986

OPTION

ALU BELT PULLEY 26T - MID-SIDE - SET



COMPOSITE BELT PULLEY

#335885	25T	INCLUDED	INITIAL SETTING
#335886	26T	INCLUDED	-



903308
SFH M3x8

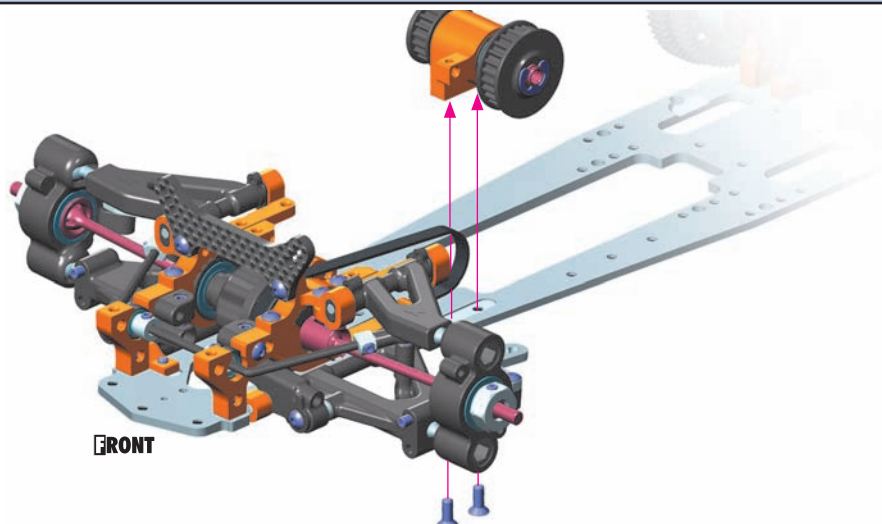

5. FRONT TRANSMISSION

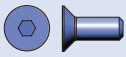

903308
SFH M3x8

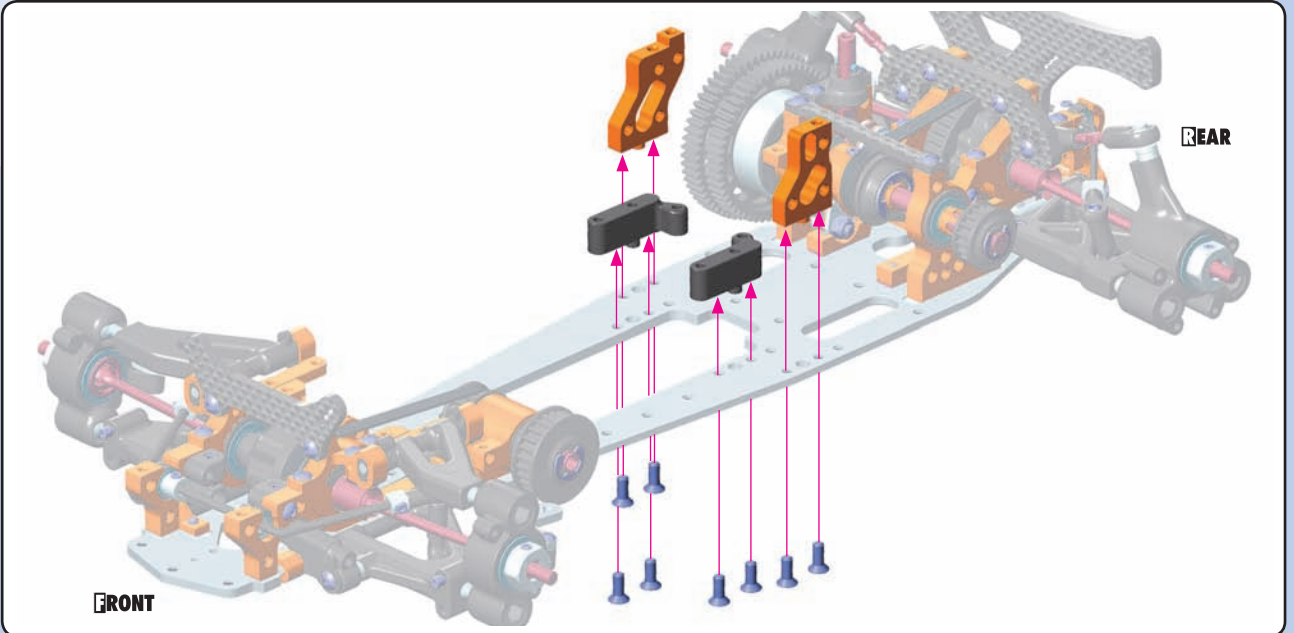

903306
SFH M3x6

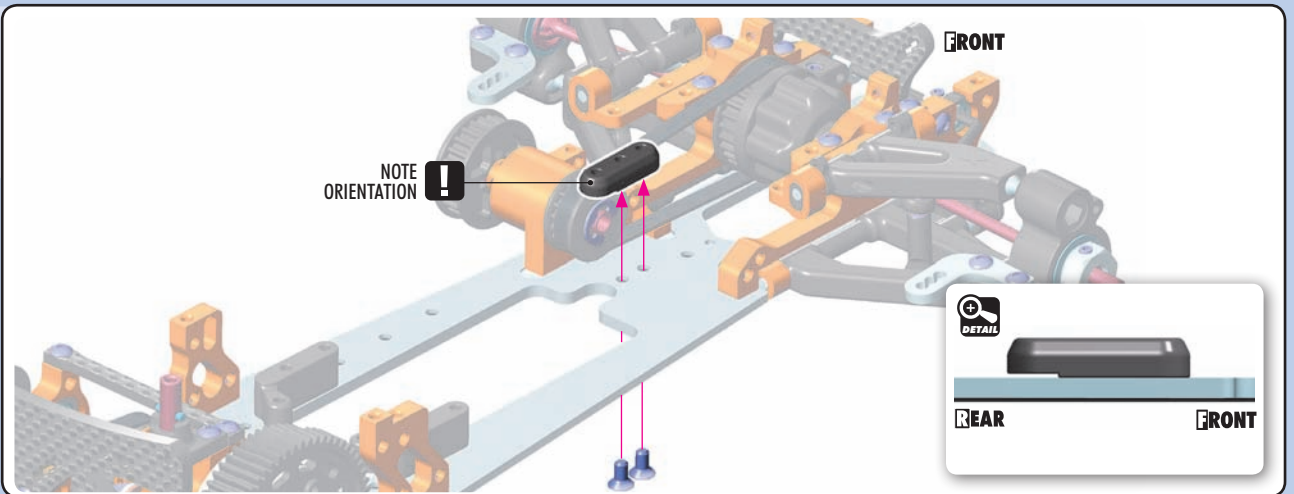

303126-K
SHIM 3x6x5



902320
SH M3x20



930508
BB 5x8x2.5



950508
BB 5x8x2.5

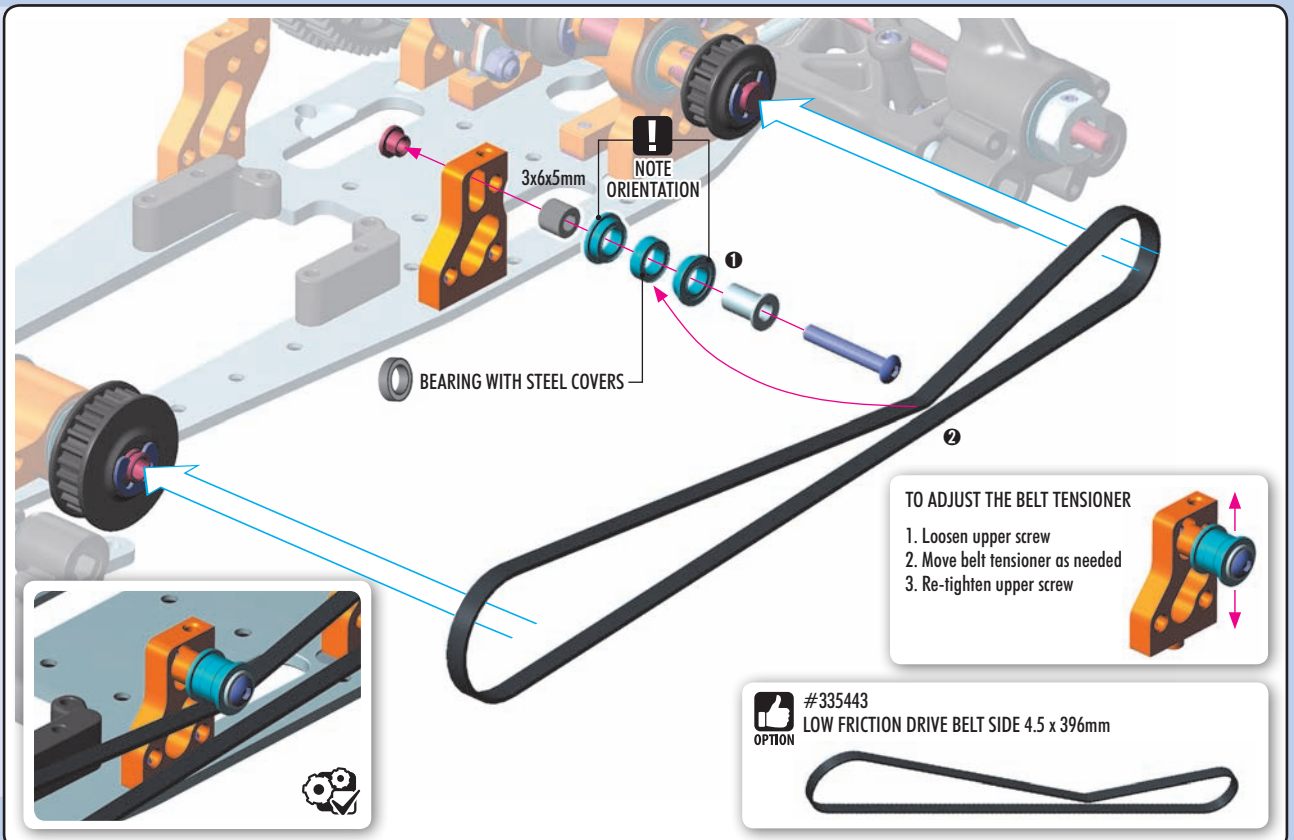

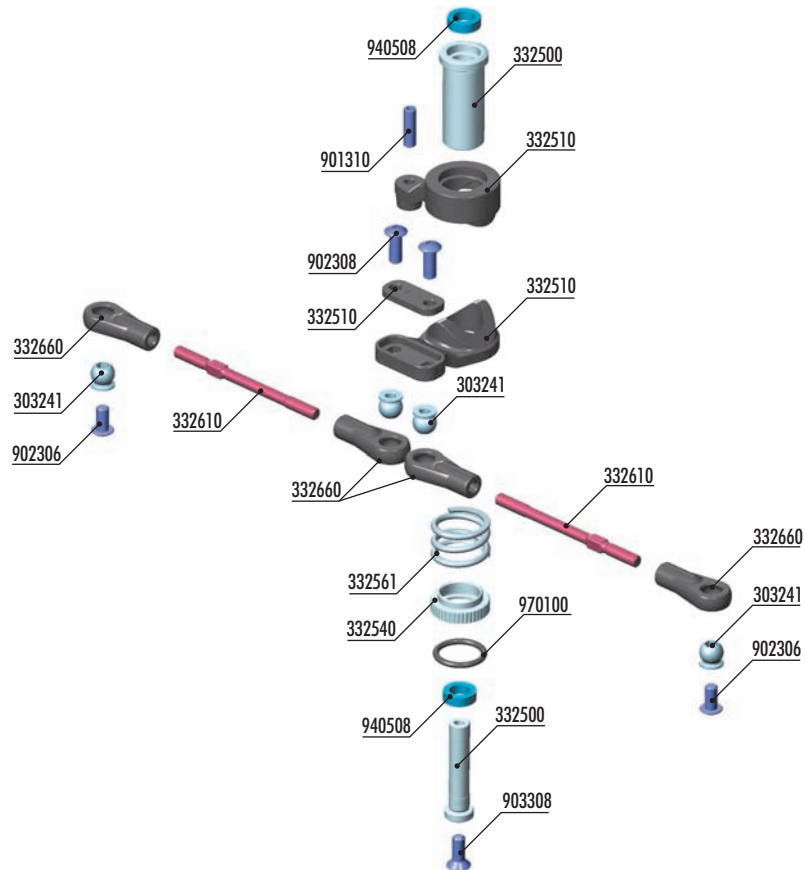

BAG

06

- 303241 PIVOT BALL UNIVERSAL 5.8 MM WITH HEX (4)
- 332500 SERVO SAVER COMPLETE SET
- 332510 COMPOSITE SERVO SAVER
- 332540 ALU SERVO SAVER ADJUSTABLE NUT
- 332561 SERVO SAVER SPRING C=14
- 332610 ADJ. TURNBUCKLE L/R 42 MM - HUDY SPRING STEEL™ (2)
- 332660 COMPOSITE STEERING & SERVO BALL JOINT 5.8 MM (4+2)

- 901310 HEX SCREW SB M3x10 (10)
- 902306 HEX SCREW SH M3x6 (10)
- 902308 HEX SCREW SH M3x8 (10)
- 903308 HEX SCREW SFH M3x8 (10)
- 940508 BALL-BEARING 5x8x2.5 RUBBER SEALED - OIL (2)
- 970100 O-RING 10 x 1.5 (10)



901310
SB M3x10



970100
O 10x1.5

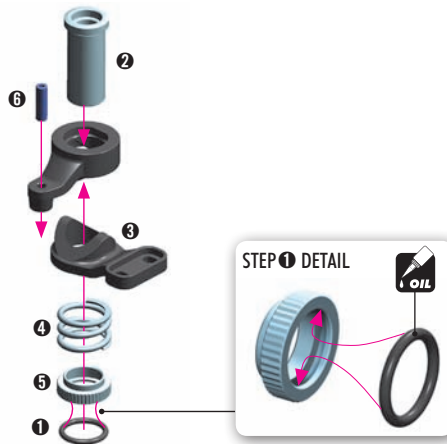

INITIAL PRELOAD

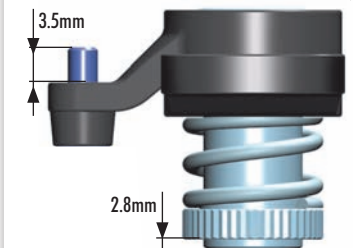

Tightening the nut makes the servo saver work harder. A harder servo saver gives the car better in-corner steering and steering response. However, it increases the risk of breaking the servo in serious crashes.



303241
BALL 5.8

TIP Install the pivot balls with Professional Multi Tool (HUDY #183011)



TIP BALL JOINT WRENCH (HUDY #181110)

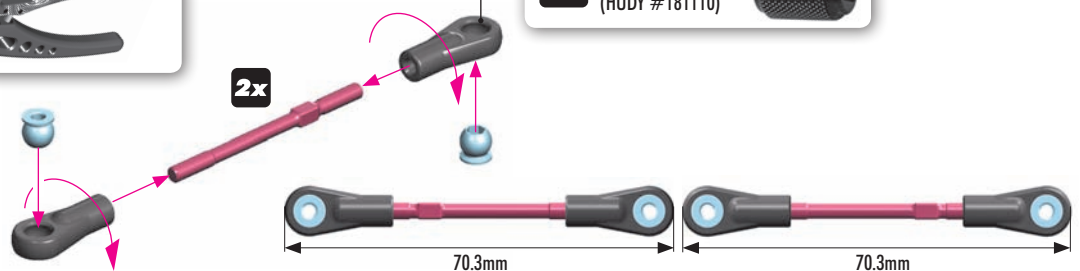

6. STEERING

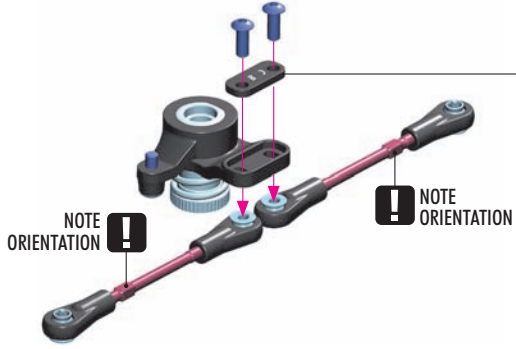
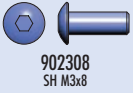

ACKERMANN SETTINGS



There are two different Ackermann inserts labeled AD and CB. You can insert each of the Ackermann inserts in two different orientations which will result in the different Ackermann settings. Note the orientation of the mounting positions.

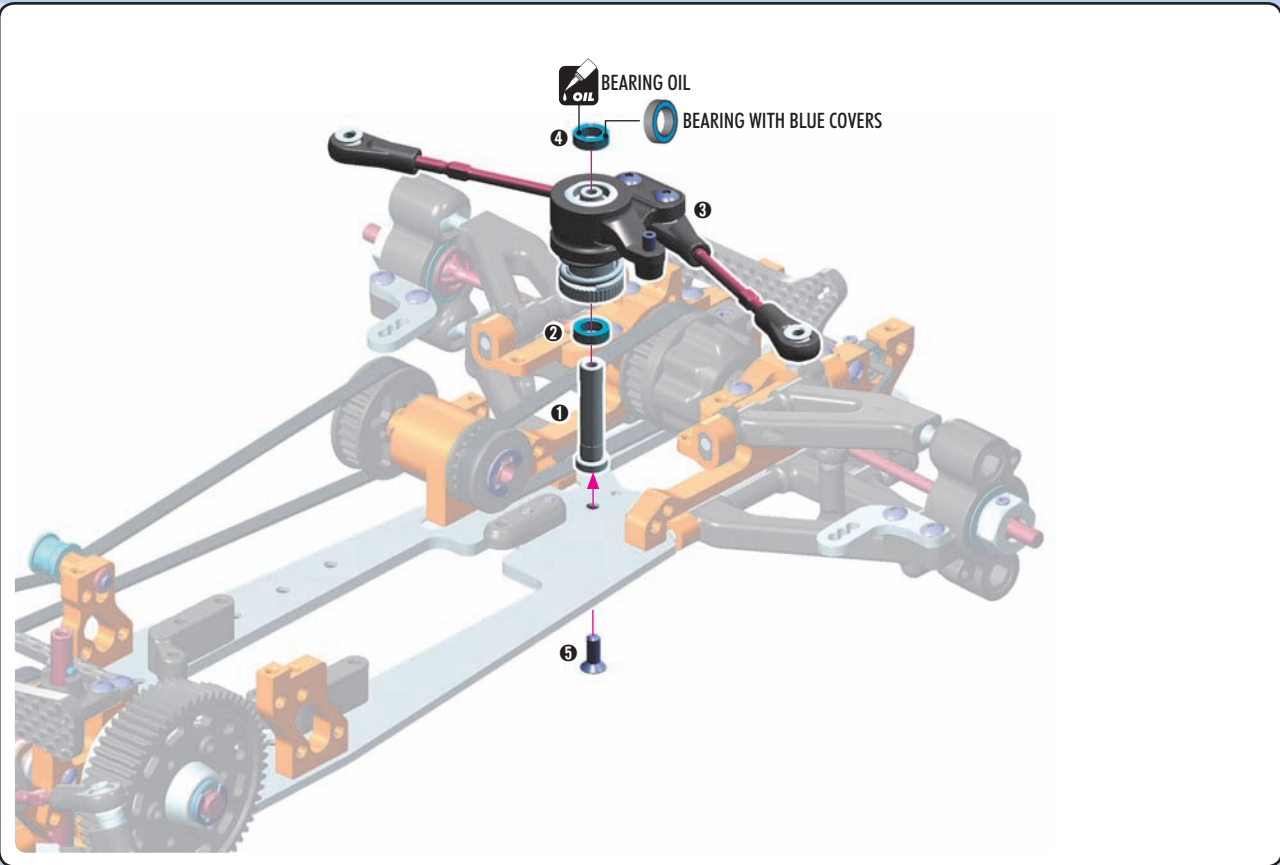

2x L=R BUMPSTEER ADJUSTMENT ALTERNATIVE 1 (INITIAL SETTING)

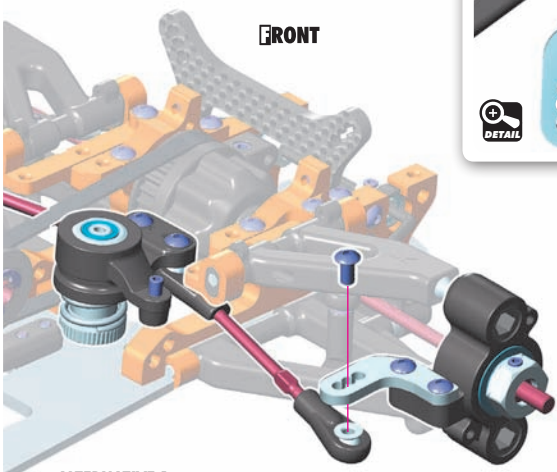

ALTERNATIVE 1
Extension for the steering block mounted from the TOP.
The car has maximum steering response and in-corner steering. Recommended bumpsteer setting for big, hard tires.

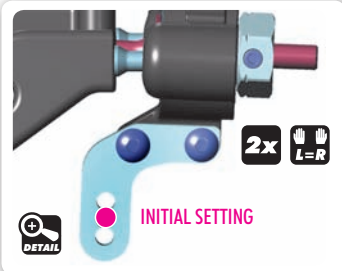

2x L=R BUMPSTEER ADJUSTMENT ALTERNATIVE 2

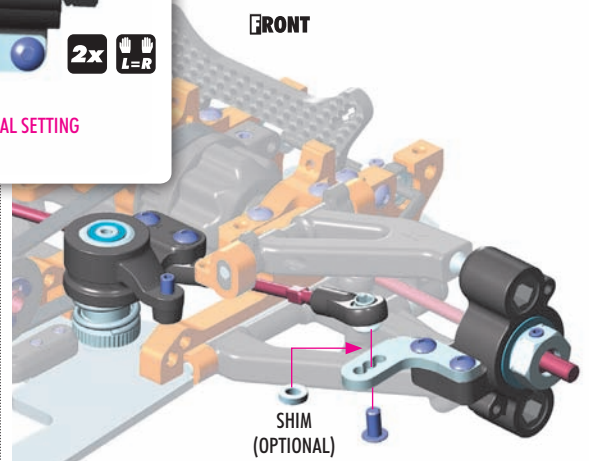

ALTERNATIVE 2
Extension for the steering block mounted from the BOTTOM with extra shims.
By adding shims, the car becomes less responsive, but easier to drive. Recommend bumpsteer setting when softer tires or tires with additive are used.

7. FUEL TANK & ELECTRONICS

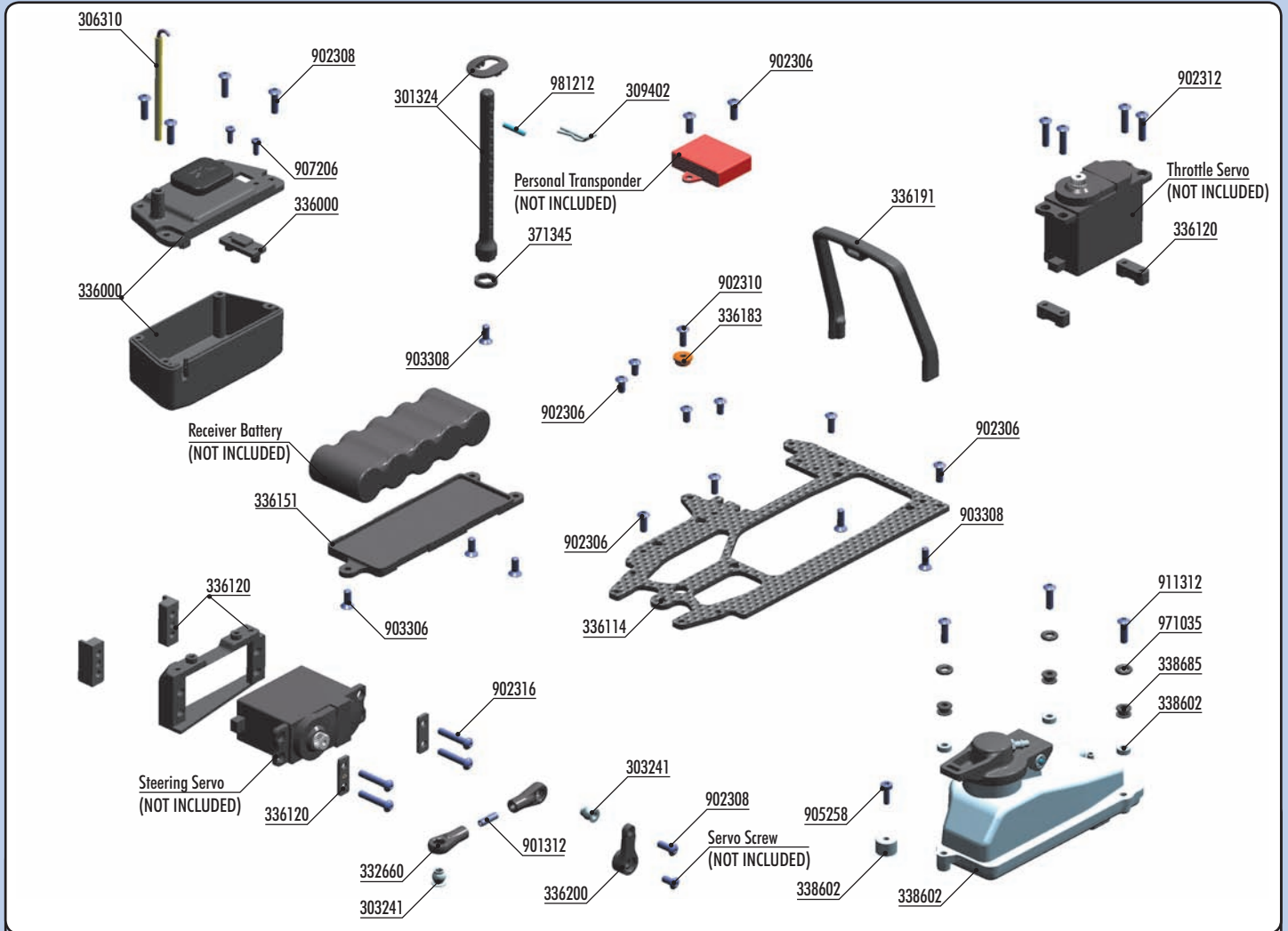

BAG



301324	FRONT BODY MOUNT SET +2MM HEIGHT	336191	COMPOSITE ROLL-OVER BAR WITH EYELET	902312	HEX SCREW SH M3x12 (10)
303241	BALL UNIVERSAL 5.8 MM HEX (4)	336200	STEERING SERVO ARMS - SET	902316	HEX SCREW SH M3x16 (10)
306310	ANTENNA TUBE (2)	338602	FUEL TANK 75CC - SET - V3	903306	HEX SCREW SFH M3x6 (10)
309402	BODY CLIP FOR 6MM BODY POST (4)	338685	FUEL TANK MOUNTING GROMMET (3)	903308	HEX SCREW SFH M3x8 (10)
332660	COMPOSITE STEERING & SERVO BALL JOINT 5.8 MM (4+2)	371345	COMPOSITE SHIM FOR BODY POST (2)	905258	SCREW PHILLIPS 2.5x8 (10)
336000	COMPOSITE RECEIVER CASE - V2			907206	SCREW PHILLIPS M2x6 (10)
336114	GRAPHITE RADIO PLATE - MULTI-FLEX™			911312	HEX SCREW FL. SH M3x12 (10)
336120	COMPOSITE STEERING SERVO HOLDER - SET	901312	HEX SCREW SB M3x12 (10)	971035	SILICONE O-RING 3.5x2 (10)
336183	ALU RADIO PLATE MULTI-FLEX™ BUSHING (2)	902306	HEX SCREW SH M3x6 (10)	981212	PIN 2x12 (10)
336151	COMPOSITE BATTERY PLATE	902308	HEX SCREW SH M3x8 (10)		
		902310	HEX SCREW SH M3x10 (10)		



903308
SFH M3x8

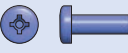

905258
2.5x8



911312
SFH M3x12



971035
O 3.5x2

IMPORTANT!

Tighten the screws gently to make sure that the O-ring does not bind. The purpose of the O-rings is to allow movement of the fuel tank in all directions.

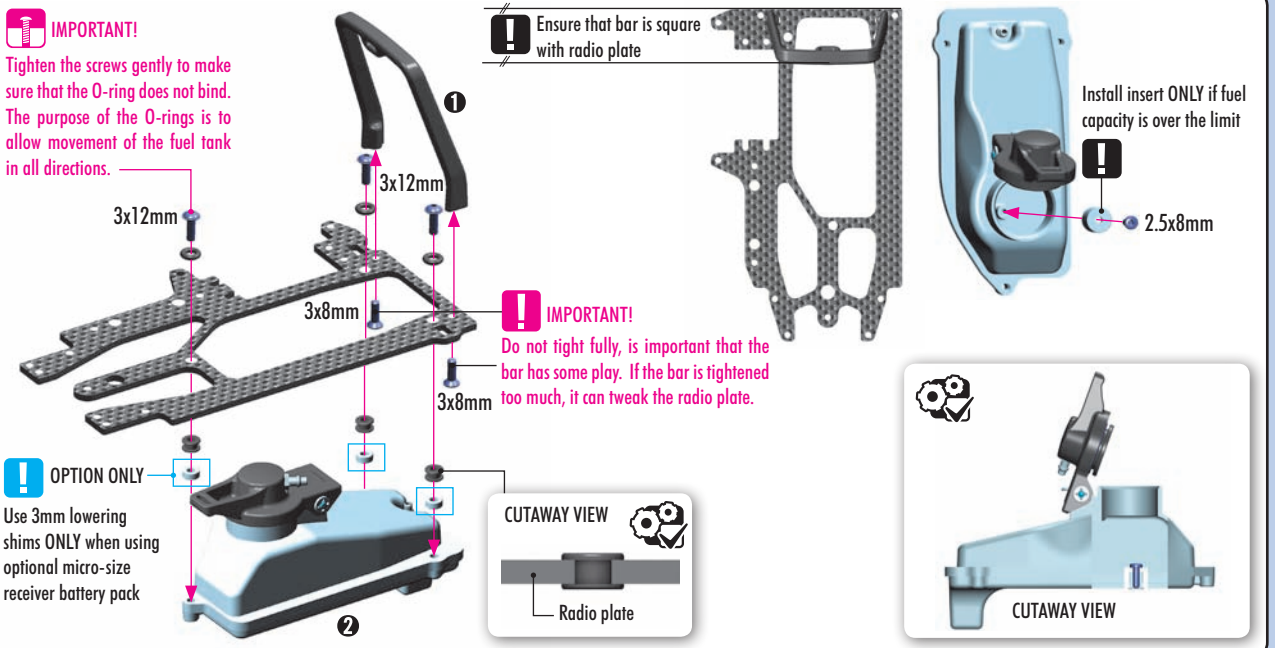

7. FUEL TANK & ELECTRONICS

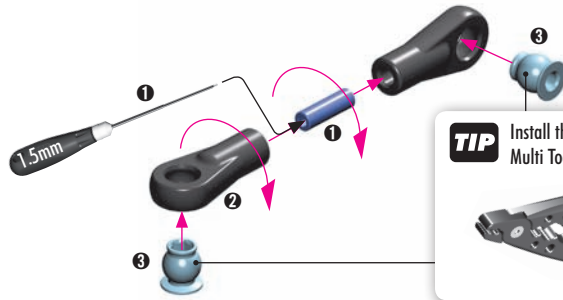

TIP Install the pivot balls with Professional Multi Tool (HUDY #183011)



Note the 90° angle difference between the ball joints

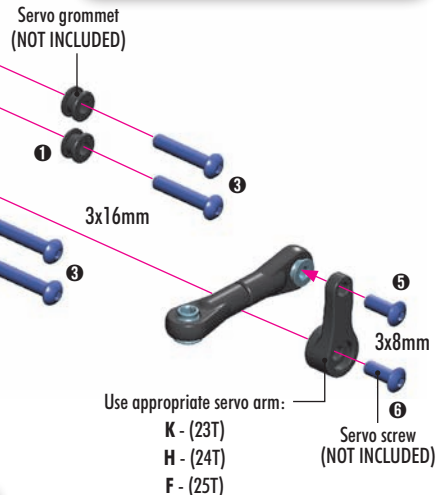
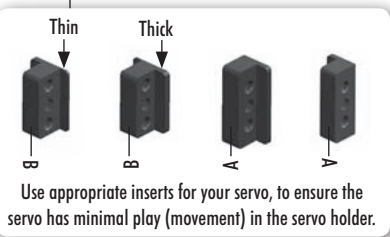
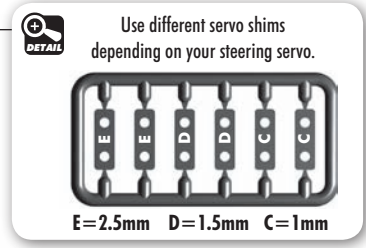
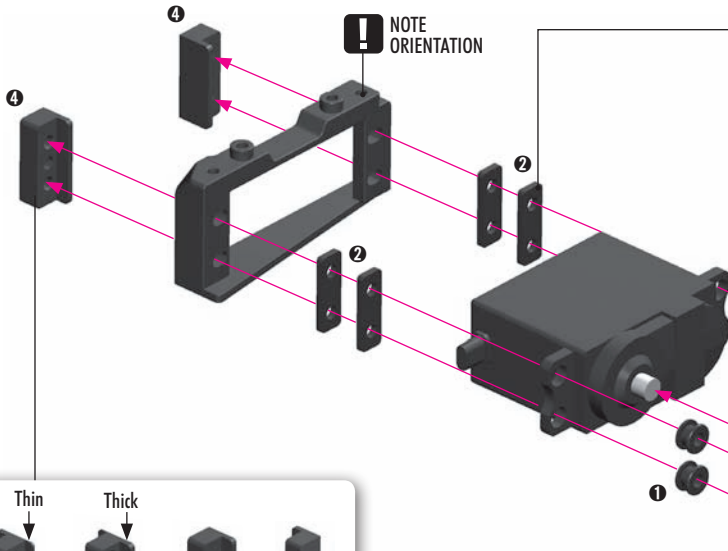
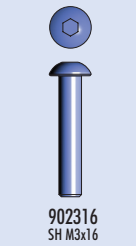

OPTION	ALU SERVO HORNS - OFFSET	CLAMP ALU SERVO HORNS - OFFSET
#293491	KO, Sanwa - 23T	#293401 KO, Sanwa - 23T
#293492	Hitec - 24T	#293402 Hitec - 24T
#293493	Futaba - 25T	#293403 Futaba - 25T

For more in-corner steering and better steering response, aluminum servo horns may be used.

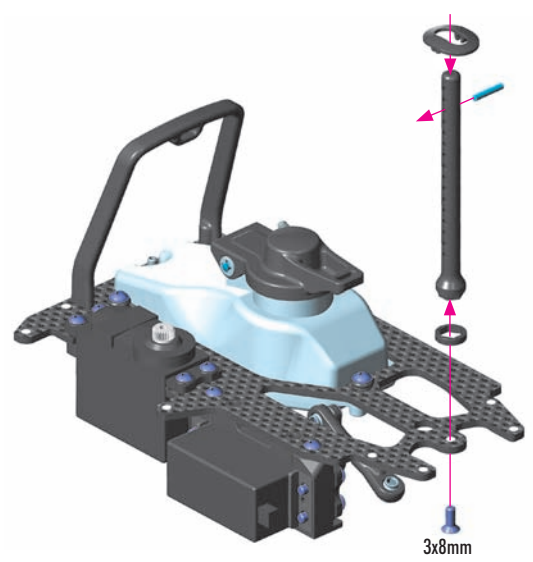
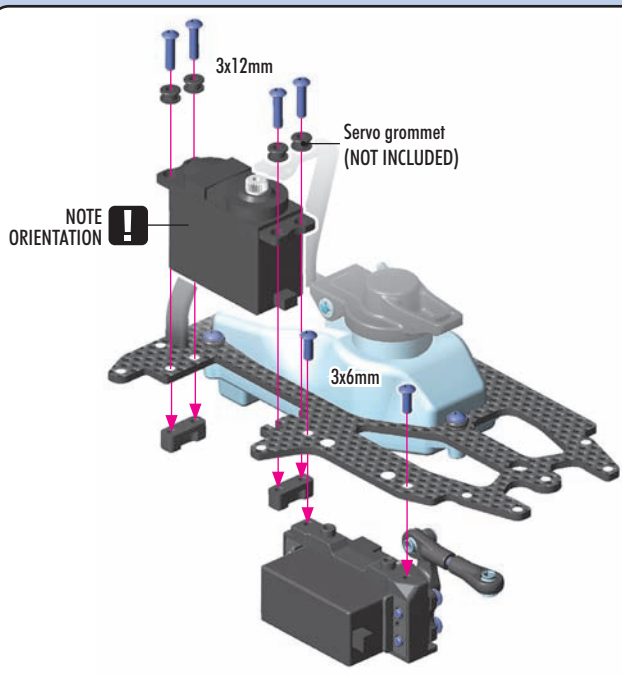
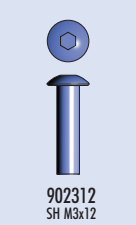

7. FUEL TANK & ELECTRONICS



902306
SH M3x6



902310
SH M3x10

NO FLEX

When the bushing is used, the radio plate does not flex around the servo saver.

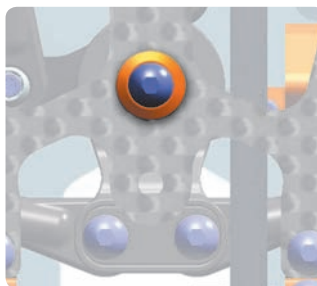

Recommended for softer tires or tires with additive to improve stability and make the car easier to drive.

FLEX INITIAL SETTING

When the bushing is not used, the radio plate flexes around the servo saver.

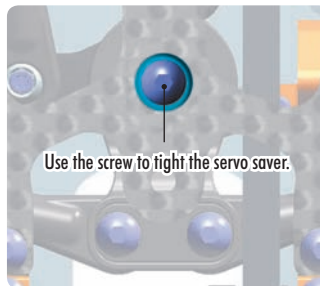

Recommended for spec hard tires to improve in-corner steering.

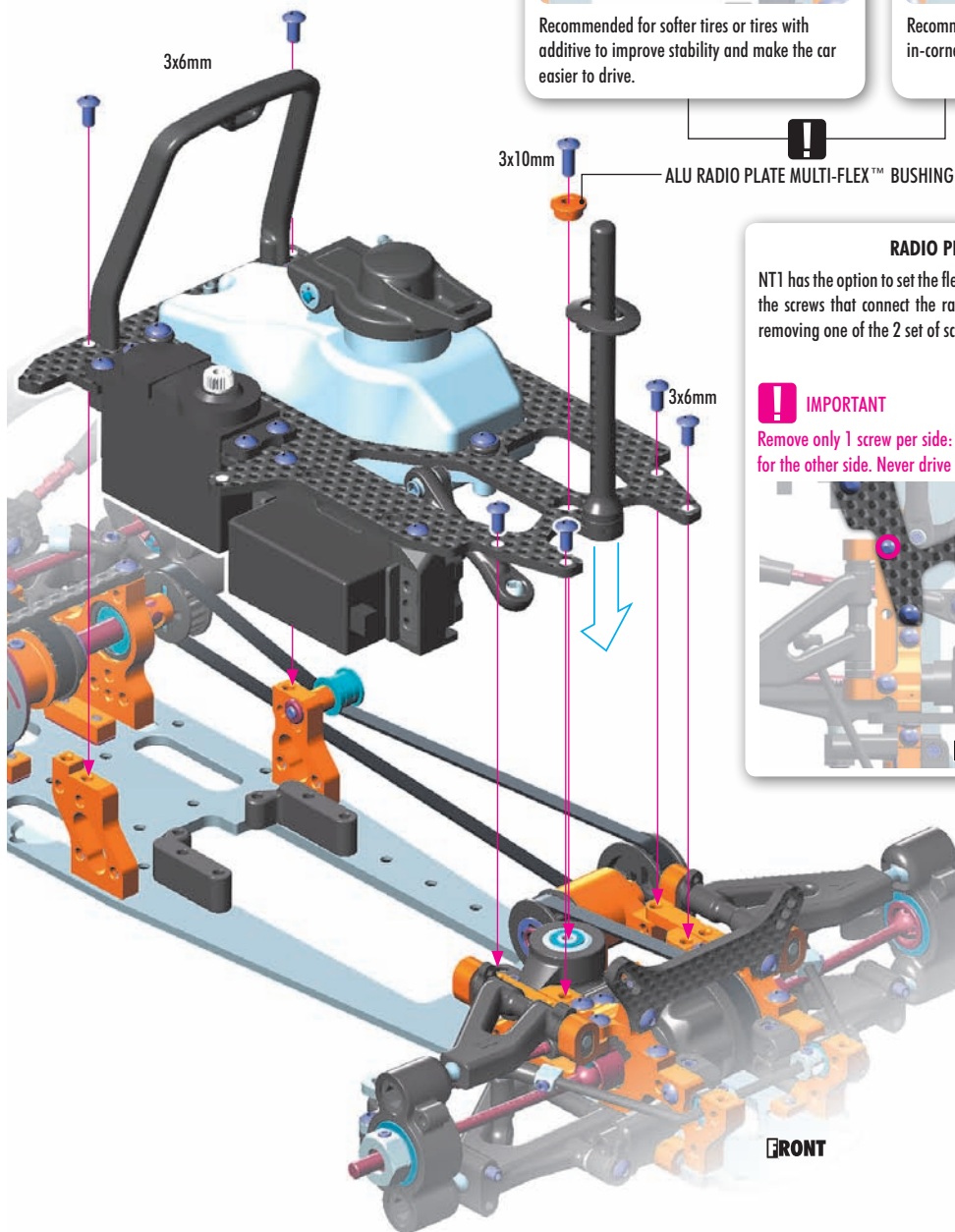

RADIO PLATE MULTI-FLEX™

NT1 has the option to set the flex setting also by tightening and loosening the screws that connect the radio plate with the upper arm holder. By removing one of the 2 set of screws, in-corner steering is improved.

! IMPORTANT
Remove only 1 screw per side: either the front or the rear screw. Repeat for the other side. Never drive with all four screws removed.

FRONT

DETAIL

DETAIL

90°~95°

Servo arm must be perpendicular to linkage when servo is in neutral.

DETAIL

Attach steering linkage to servo saver.

7. FUEL TANK & ELECTRONICS

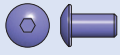

902306
SH M3x6



902308
SH M3x8



907206
SP M2x6

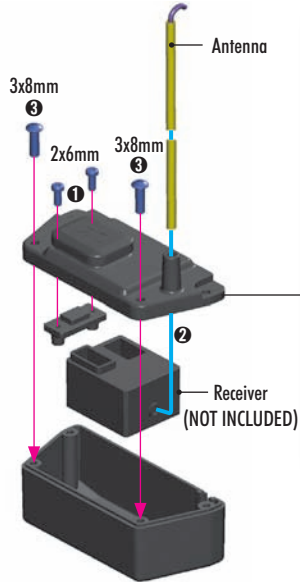

Route servo and transponder leads into box and seal with silicone sealant



If the receiver box has 2 different-size openings for cable entry (narrow and wider), cut away the tab for the appropriate opening to allow the cables to fit properly.

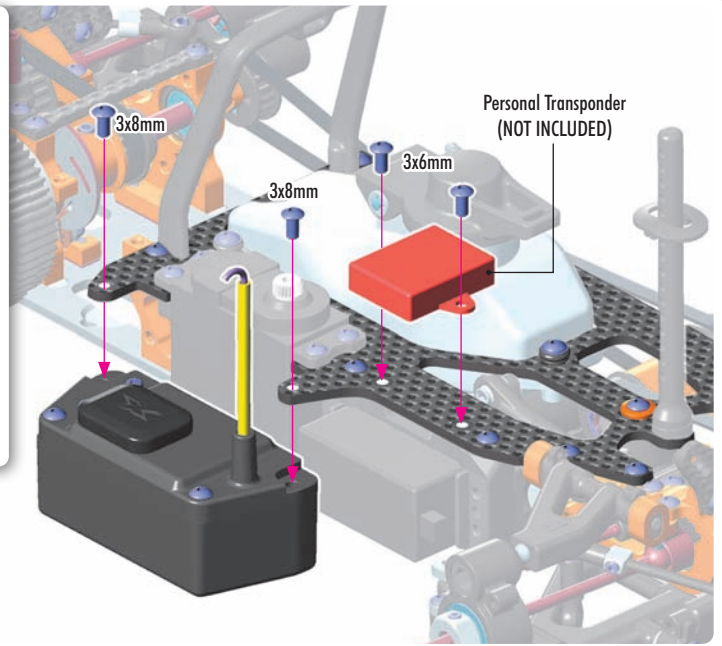
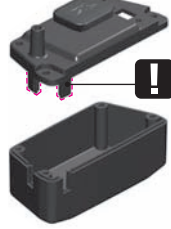

Use an appropriate receiver battery pack.

The NT1 accommodates standard 5-cell receiver packs or optional micro-size packs.

Battery (NOT INCLUDED)

Use tape to mount the receiver battery pack to the lower holder.

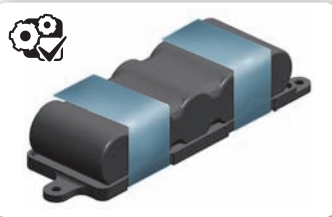

#336156
BRASS BATTERY PLATE FOR LIPO BATTERIES-100g - V2

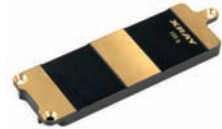

#336155
GRAPHITE BATTERY PLATE - V2



The battery holder has a direct effect on chassis flex and car weight.

Use the GRAPHITE battery plate to slightly stiffen the chassis flex for better stability.

Use the BRASS battery plate to stiffen the chassis flex and increase weight. Recommended for high-traction tracks or soft tires (or tires with additive) to reduce traction roll and make the car easier to drive.



903306
SFH M3x6

FRONT

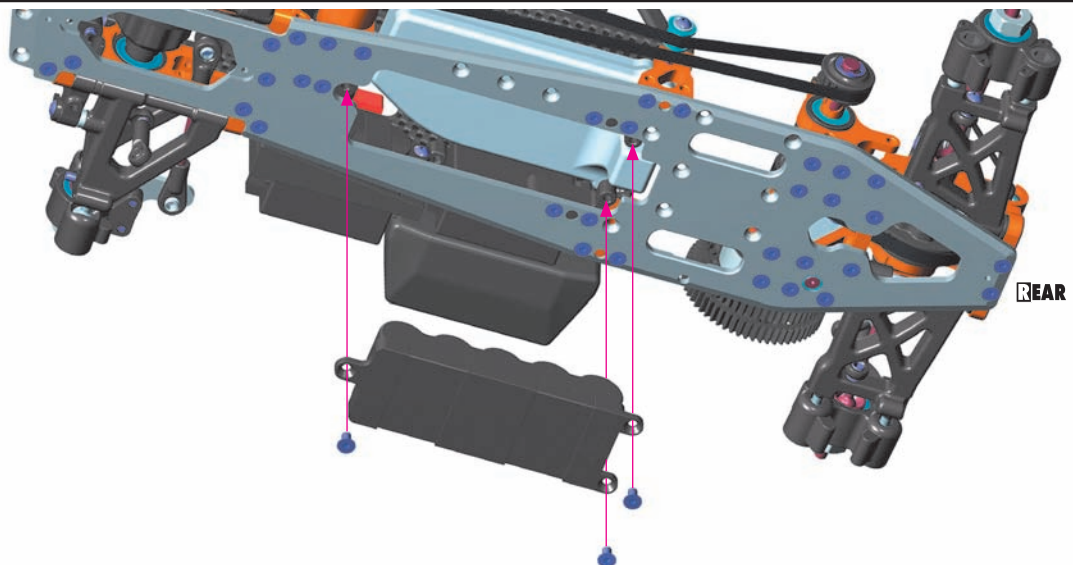

REAR

8. ENGINE & CLUTCH

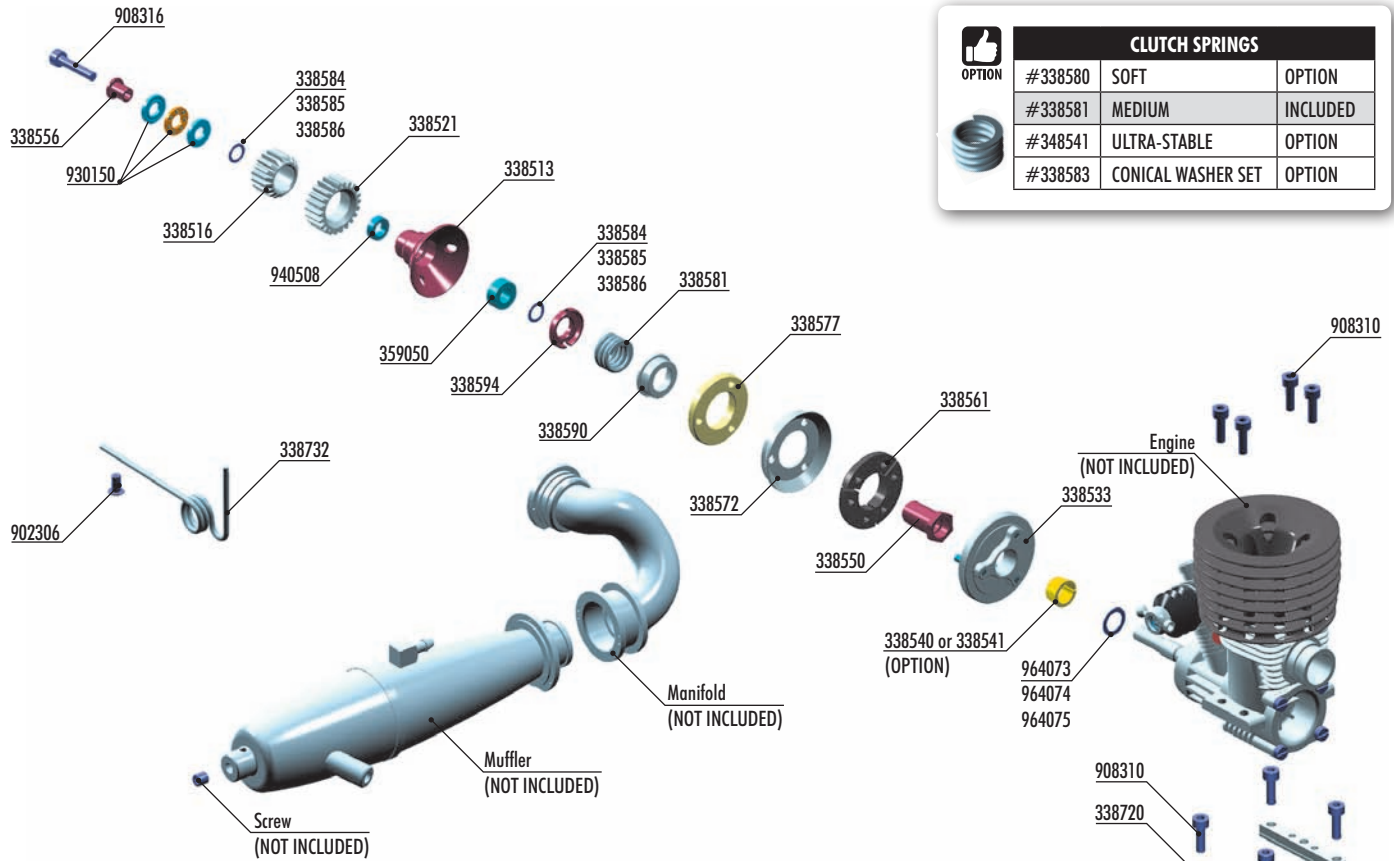

CLUTCH SPRINGS			
OPTION	#338580	SOFT	OPTION
	#338581	MEDIUM	INCLUDED
	#348541	ULTRA-STABLE	OPTION
	#338583	CONICAL WASHER SET	OPTION

XRAY FLYWHEEL COLLAR			
OPTION	#338540	ø6.0mm	OPTION
	#338541	ø7.0mm	OPTION

#338721
BRASS 1-PIECE ENGINE MOUNT

#338713
ALU MONOBLOCK ENGINE MOUNT

#338578
CLUTCH SHOE - HIGH-DYNAMIC - RED

1ST PINION GEARS - XCA HARDCOATED			
OPTION	#338515	15T (1st)	OPTION
	#338516	16T (1st)	INCLUDED
	#338517	17T (1st)	OPTION
	#338518	18T (1st)	OPTION
	#338519	19T (1st)	OPTION

2ND PINION GEARS - XCA HARDCOATED			
OPTION	#338520	20T (2nd)	OPTION
	#338521	21T (2nd)	INCLUDED
	#338522	22T (2nd)	OPTION
	#338523	23T (2nd)	OPTION
	#338524	24T (2nd)	OPTION
	#338525	25T (2nd)	OPTION

#338514
ALU NICKEL-COATED LIGHTWEIGHT CLUTCH BELL 26MM - HIGH-DYNAMIC



- 33 8502 XCA (XRAY CENTRIFUGAL-AXIAL) CLUTCH SET - REVERSE
- 33 8513 XCA CLUTCHBELL - HIGH DYNAMIC - HUDY STEEL
- 33 8516 XCA ALU 7075 T6 HARDCOATED PINION GEAR - 16T (1ST)
- 33 8521 XCA ALU 7075 T6 HARDCOATED PINION GEAR - 21T (2ND)
- 33 8533 FLYWHEEL REVERSE - FLAT - ALU 7075 T6 - HARDCOATED - 32MM
- 33 8540 FLYWHEEL COLLAR 7MM - NOVAROSSI (OPTION)
- 33 8541 FLYWHEEL COLLAR 6MM - PICCO (OPTION)
- 33 8550 FLYWHEEL NUT - HUDY SPRING STEEL™
- 33 8556 CLUTCH BELL BUSHING - HUDY SPRING STEEL™
- 33 8561 CLUTCH FLYWEIGHT SET - HIGH DYNAMIC
- 33 8572 ALU CLUTCH DISK - CONICAL - SWISS 7075 T6
- 33 8577 CLUTCH SHOE - HIGH DYNAMIC - YELLOW
- 33 8581 CLUTCH SPRING - MEDIUM
- 33 8584 SHIM 5x7x0.2 (10)
- 33 8585 SHIM 5x7x0.3 (10)
- 33 8586 SHIM 5x7x0.5 (10)
- 33 8590 CLUTCH SPRING CUP - ALU 7075 T6

- 33 8594 CLUTCH PRELOAD ADJ. NUT - HUDY SPRING STEEL™
- 33 8720 ALU STAND FOR ENGINE MOUNT (2)
- 33 8722 ALU ENGINE MOUNTS - LOWER (L+R)
- 33 8732 EXHAUST MOUNTING WIRE - EXTRA-LONG
- 35 9050 BALL-BEARING 5x10x4 STEEL SEALED - GREASE (2)
- 90 2306 HEX SCREW SH M3x6 (10)
- 90 3310 HEX SCREW SFH M3x10 (10)
- 90 8310 HEX SCREW SOCKET HEAD CAP M3x10 (10)
- 90 8316 HEX SCREW SOCKET HEAD CAP M3x16 (10)
- 93 0150 CARBIDE BALL-BEARING AXIAL F5-10 5x10x4
- 94 0508 BALL-BEARING 5x8x2.5 RUBBER SEALED - OIL (2)
- 96 4073 WASHER S 7x10x0.2 (10)
- 96 4074 WASHER S 7x10x0.3 (10)
- 96 4075 WASHER S 7x10x0.5 (10)

8. ENGINE & CLUTCH

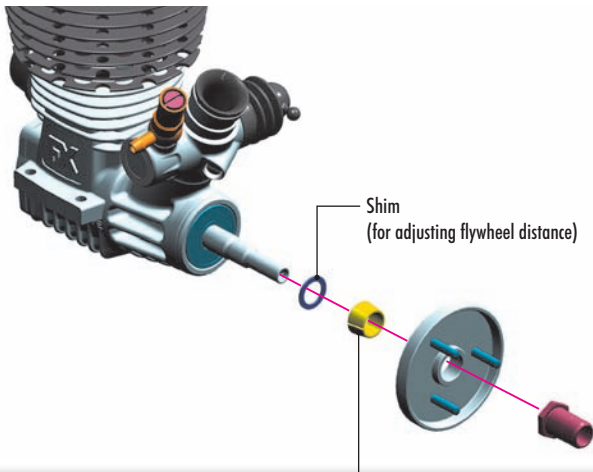

XRAY FLYWHEEL COLLAR		
#338540	ø6.0mm	OPTION
#338541	ø7.0mm	OPTION



Use the flywheel collar that comes with your engine, or use optional XRAY collars.

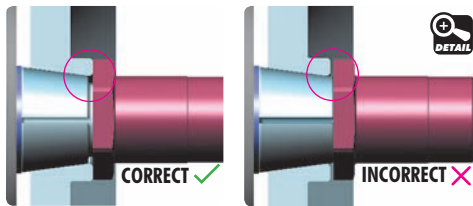

The flywheel collar must stay inside the flywheel.

If the flywheel collar is too long – if it is flush with the flywheel or protrudes slightly – remove a small amount of material from the end, or use an XRAY collar.

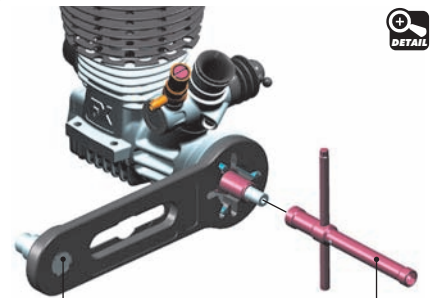

Hold the flywheel using HUDY Flywheel Tool #182010

Tighten the clutch nut using HUDY tool #107581

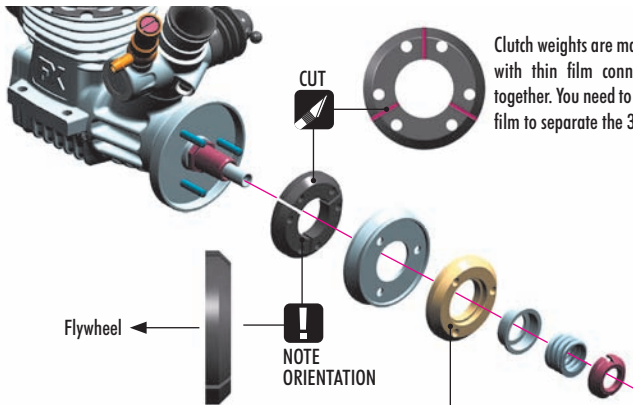

Clutch weights are machined as 1 piece, with thin film connecting the pieces together. You need to cut the connecting film to separate the 3 shoes.

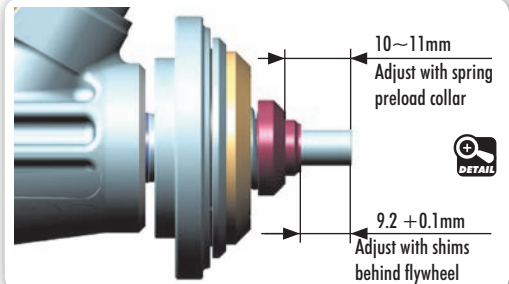

INITIAL POSITION for flywheel pins

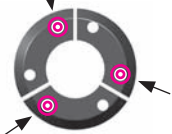

#338578
CLUTCH SHOE- HIGH-DYNAMIC - RED



CLUTCH SPRINGS		
#338580	SOFT	OPTION
#338581	MEDIUM	INCLUDED
#348541	ULTRA-STABLE	OPTION
#338583	CONICAL WASHER SET	OPTION



TECH TIP FOR EXTRA BOTTOM-END POWER

For extra bottom-end power, thread a M3x4 setscrew (#901304) into each clutch flyweight as shown. The set-screw will add more weight to the end of the flyweight which will cause the flyweight to open harder, giving more bottom-end power. This is recommended for high-traction tracks where bottom-end power is required.

IMPORTANT!

Install set-screw into free (non-pivot) end of flyweight.

3x

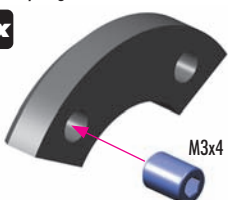

After inserting the set-screw, some excess material may come out of the hole. REMOVE this excess material with a knife.

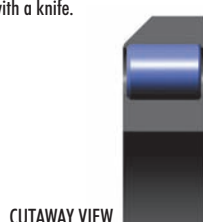

TECH TIP FOR NT1 CLUTCH SHOE

To ensure that the NT1 clutch shoe works properly and for a long time, it is very important to run in the clutch shoe.



Please follow these run-in steps to help ensure proper clutch operation:

- 1 Install clutch according to this Instruction Manual.
- 2 Check that the spring preload is not too much; for run-in process use less preload.
- 3 When you start the engine, the clutch should start to engage under low RPM. If the clutch engages only under high RPM, stop the engine and loosen the spring preload collar. Repeat until the clutch engages under low RPM.
- 4 Run in the clutch shoe on the track, or on the starter box if you have only limited time. (We recommend running it in on the track.)
- 5 Run in the clutch shoe for 1 tank of fuel using a soft preload setting, and then after that slightly tighten the spring preload. DO NOT run in the clutch shoe under high RPM.
- 6 Continue this process until the clutch shoe is properly run in; this will be indicated by a dark and glossy surface colour on the top of the clutch shoe.

8. ENGINE & CLUTCH



903310
SFH M3x10

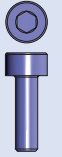

908310
SCH M3x10

The engine should be installed on the split mounts as follows:

STEP 1: Attach lower mounts to chassis.

STEP 2: Attach upper mounts to lower mounts.

STEP 3: Attach engine to upper mounts.

STEP 4: Loosen lower mount screws, adjust gear mesh, and then retighten lower mount screws.

After the gear mesh is initially set, you can remove the engine AND upper mounts as one assembly by removing the screws holding the upper mounts to the lower mounts. When re-installing the engine, you will not have to re-adjust the gear mesh.

DETAIL

Adjust gear mesh so there is minimal play between the gears.

Too **TIGHT** gear mesh will put excessive strain on all parts and damage the parts.

Too **LOOSE** gear mesh may result in stripped gears.

NOTE
ORIENTATION

NOTE
ORIENTATION

#338713
ALU MONOBLOCK ENGINE MOUNT
OPTION

Reinforces the chassis flex around the engine area for improved steering.
RECOMMENDED FOR MEDIUM-HIGH TRACTION TRACKS

#338721
BRASS 1-PIECE ENGINE MOUNT
OPTION

Reinforces the chassis flex around the engine area and moves the weight balance more to the rear for even more steering and rotation of the car.
RECOMMENDED FOR HIGH-TRACTION TRACKS



902306
SH M3x6

Attach manifold to engine using appropriate springs

Thread lock (screw NOT INCLUDED)

9. CARB LINKAGE & BODYMOUNTS

#334061-0
ALU BRAKE POST ARM - SWISS 7075 T6 - ORANGE
OPTION

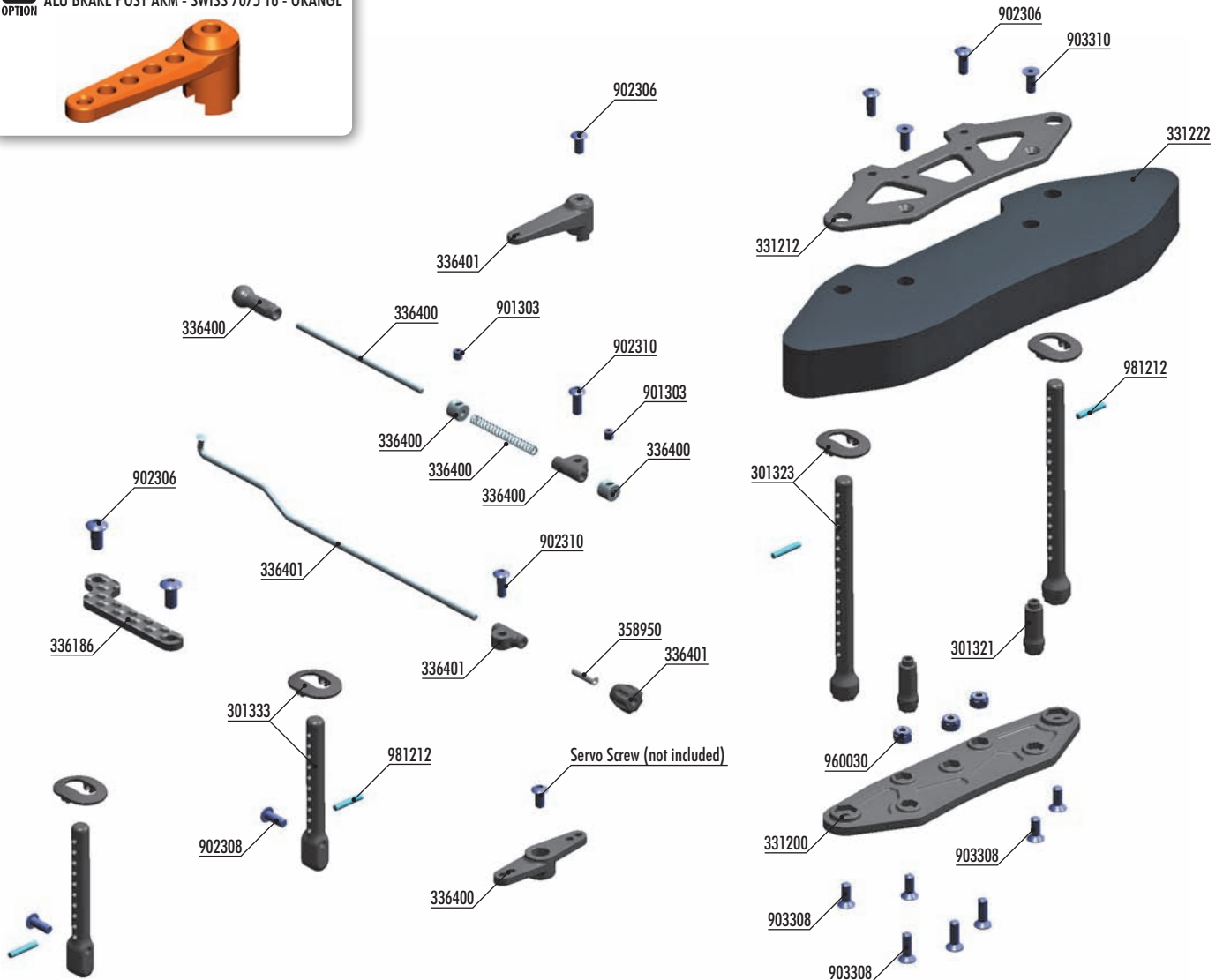

FRONT BODY MOUNTS

#301322	0mm	OPTION
#301323	+1mm	INCLUDED
#301324	+2mm	OPTION



#301351-0
ALU ADJUSTABLE BODY POST STOP (2)
OPTION

Very handy, easily externally adjustable body post from Swiss 7075 T6 aluminum. Allows for adjustment of body height by 3mm without needing to change the position on the body post.



#331201
COMPOSITE WIDE BUMPER
OPTION



The wider front bumper is used without the foam bumper.

The wider front bumper improves steering, but may allow more front damage under hard crashes.



#331216
GRAPHITE UPPER HOLDER FOR BUMPER 2.5MM
OPTION



#331221
FOAM BUMPER FOR ANTI-ROLL BAR - HARD - V2
OPTION



BAG

09

30 1321	COMPOSITE BRACE FOR BUMPER (2)	35 8951	SIL. TUBING 1M (2.4 x 5.5MM) YELLOW (OPTION)
30 1323	FRONT BODY MOUNT SET + 1MM HEIGHT	90 1303	HEX SCREW SB M3x3 (10)
30 1333	REAR BODY MOUNT SET + 1MM HEIGHT	90 2306	HEX SCREW SH M3x6 (10)
33 1200	COMPOSITE BUMPER	90 2308	HEX SCREW SH M3x8 (10)
33 1212	COMPOSITE UPPER HOLDER FOR BUMPER	90 2310	HEX SCREW SH M3x10 (10)
33 1222	FOAM BUMPER FOR ANTI-ROLL BAR	90 3308	HEX SCREW SFH M3x8 (10)
33 6186	GRAPHITE REAR STIFFENER	90 3310	HEX SCREW SFH M3x10 (10)
33 6400	THROTTLE SYSTEM SET	96 0030	NUT M3 (10)
33 6401	BRAKE SYSTEM SET	98 1212	PIN 2x12 (10)
35 8950	SILICONE TUBING 1M (2.4 x 5.5MM)		

9. CARB LINKAGE & BODYMOUNTS



903308
SFH M3x8



960030
N M3

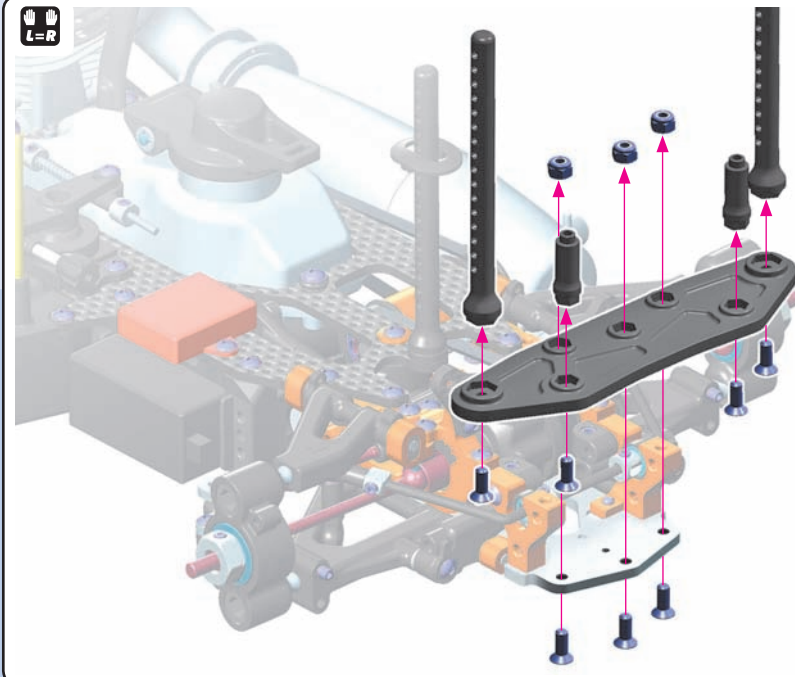

#331201
COMPOSITE WIDE BUMPER



The wider front bumper is used without the foam bumper.

The wider front bumper improves steering, but may allow more front damage under hard crashes.

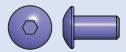

902306
SH M3x6



903310
SFH M3x10



981212
P 2x12

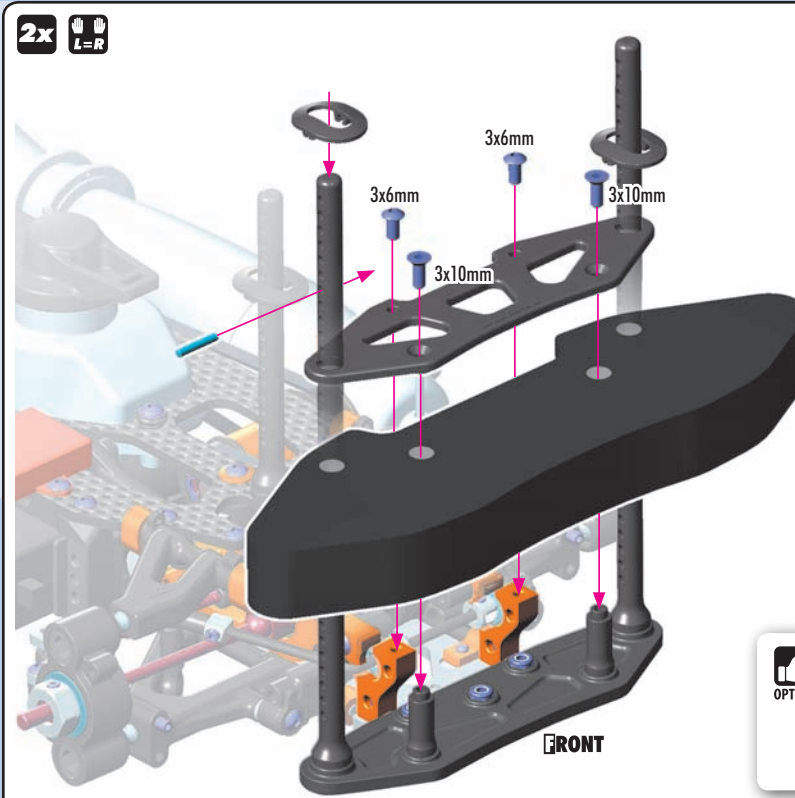

#331216
GRAPHITE UPPER HOLDER FOR BUMPER 2.5MM



#331221
FOAM BUMPER FOR ANTI-ROLL BAR - HARD - V2



#301351-0
ALU ADJUSTABLE BODY POST STOP (2)



FRONT BODY MOUNTS

#301322	0mm	OPTION
#301323	+1mm	INCLUDED
#301324	+2mm	OPTION

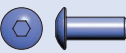

902308
SH M3x8



981212
P 2x12

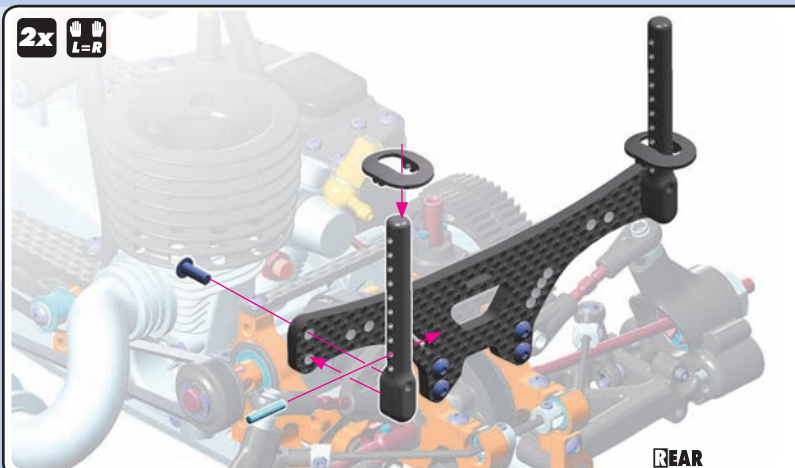

REAR BODY MOUNTS

#301332	0mm	INCLUDED
#301333	+1mm	OPTION
#301334	+2mm	OPTION



9. CARB LINKAGE & BODYMOUNTS

901303
SB M3x3



902310
SH M3x10

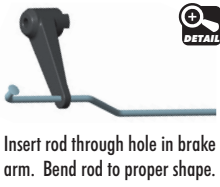

Insert rod through hole in brake arm. Bend rod to proper shape.



#334061-0
ALU BRAKE POST ARM - SWISS 7075 T6 - ORANGE

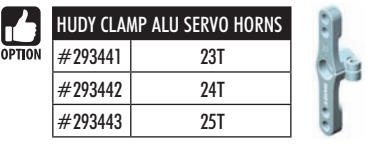

HUDY CLAMP ALU SERVO HORNS
#293441 23T
#293442 24T
#293443 25T

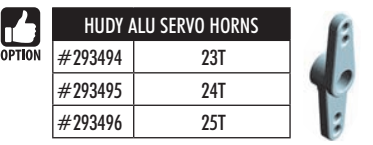

HUDY ALU SERVO HORNS
#293494 23T
#293495 24T
#293496 25T

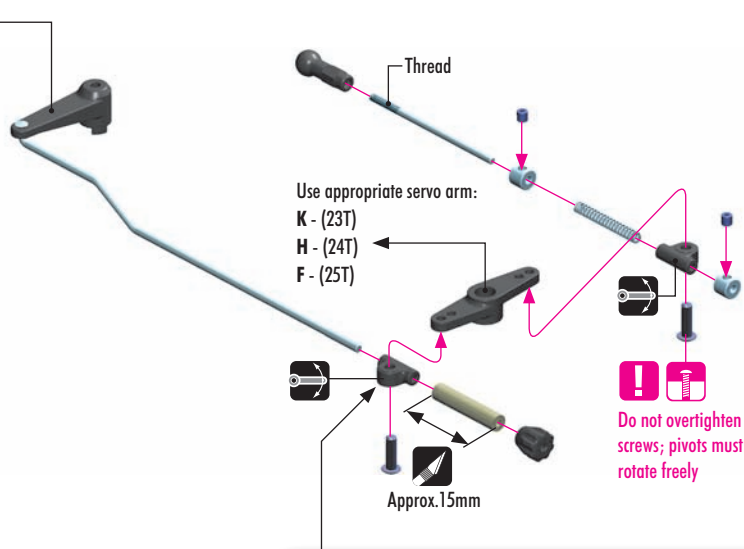

! Do not overtighten screws; pivots must rotate freely

! IMPORTANT: The composite holders and servo horn orientation depend on the servo type and servo position which can be mounted either from top of the radio plate or from the bottom.

902306
SH M3x6

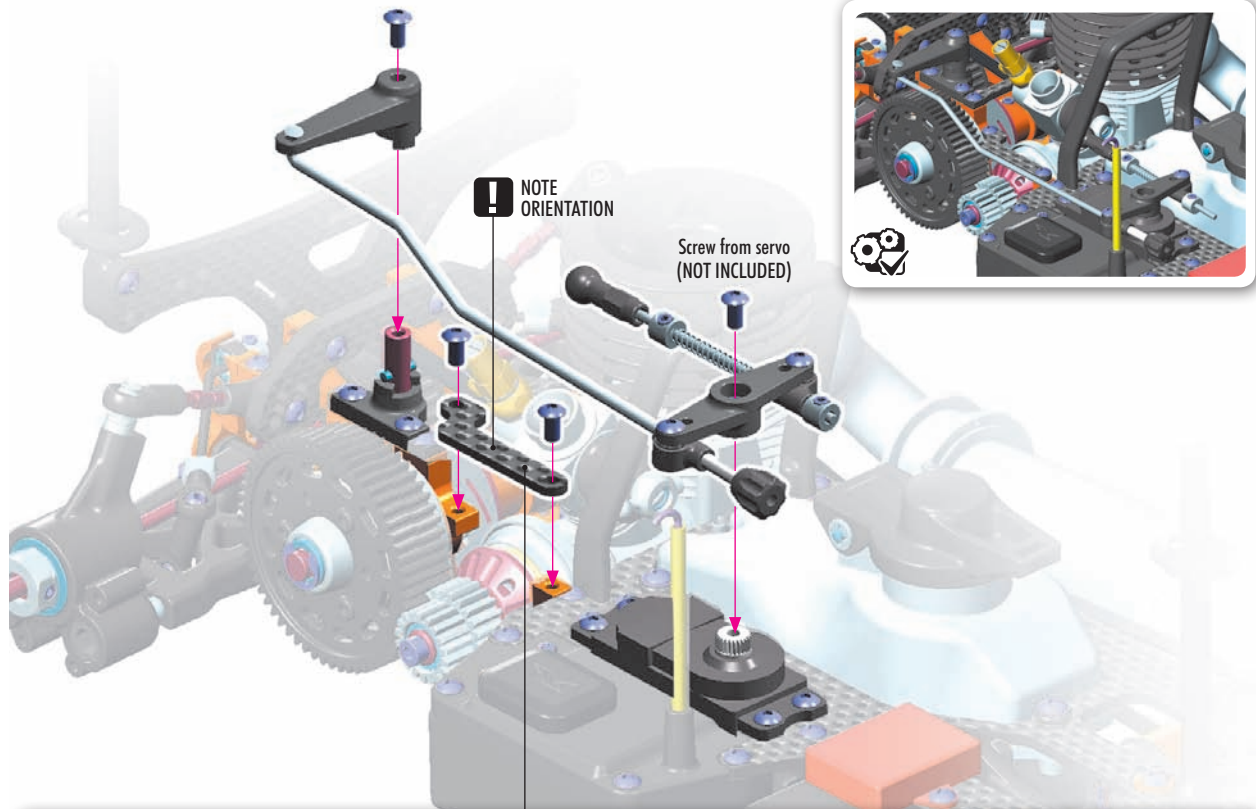

- OPTION**
- #332630 ADJ. TURNBUCKLE L/R 25 MM - HUDY SPRING STEEL™ (2)
 - #302663 COMPOSITE BALL JOINT 4.9MM - OPEN (8)
 - #362650 BALL END 4.9MM WITH THREAD 6MM (2)
 - #362651 BALL END 4.9MM WITH THREAD 8MM (2)

! IMPORTANT
It is important to have the exact length of the linkage. Too long or too short link will cause the chassis to bend and unwanted tweak problems. To check that the length is correct, composite balls must move freely.

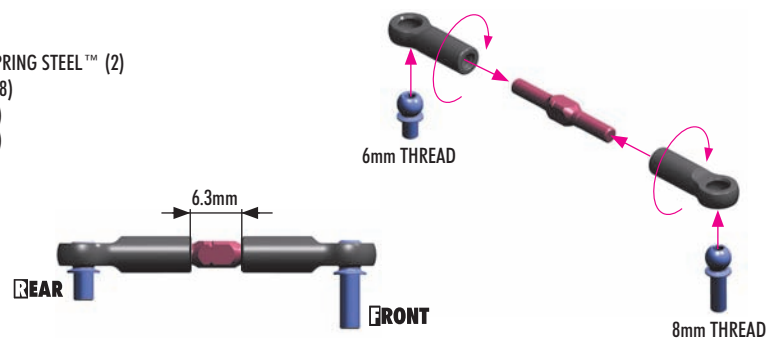

10. SHOCK ABSORBERS



#308031-0 ALU XRAY SHOCK SPRING RETAINING COLLAR - ORANGE (4)

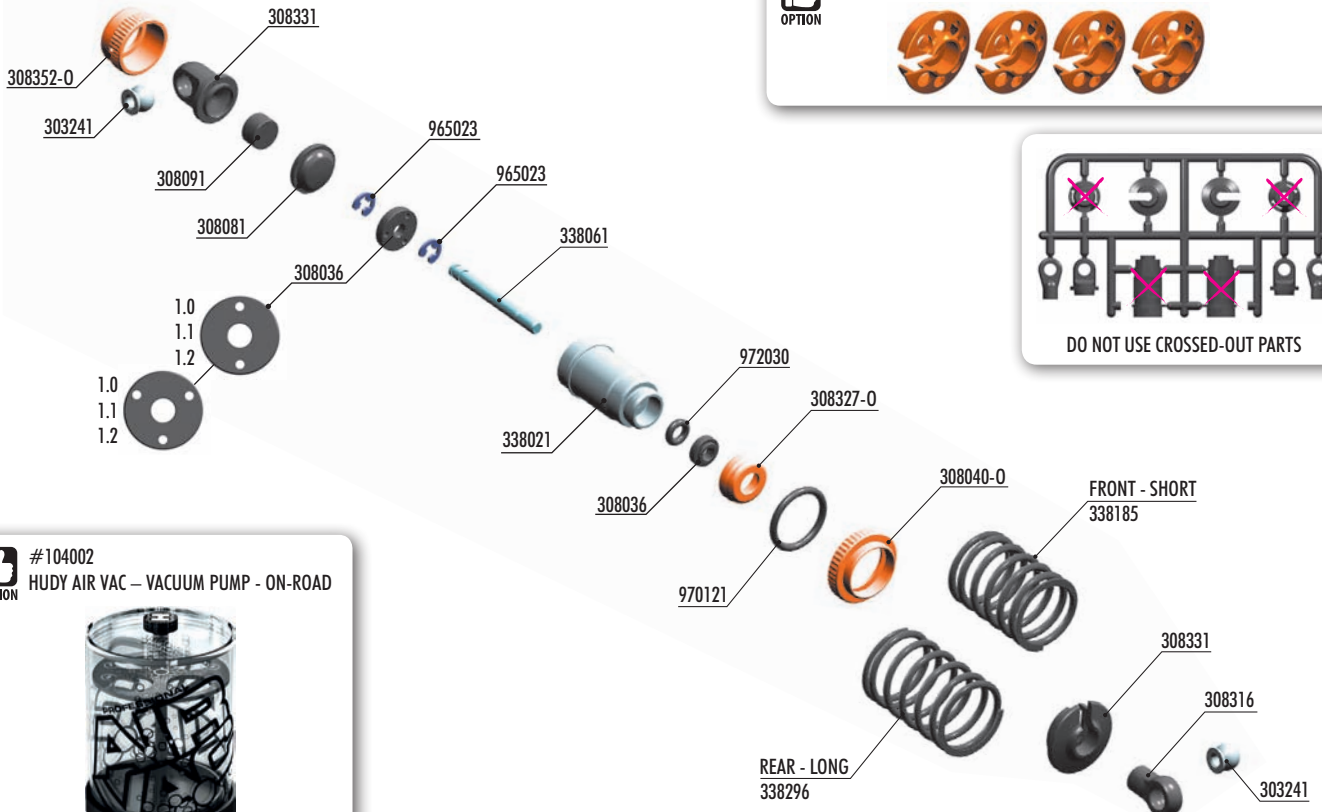
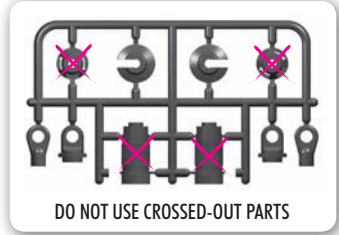

#104002 HUDY AIR VAC - VACUUM PUMP - ON-ROAD



BAG

10

- | | |
|---|---|
| 303241 BALL UNIVERSAL 5.8 MM HEX (4) | 338001-0 ALU SHOCK ABSORBER-SET - ORANGE (2) |
| 308036 COMPOSITE NON-ADJUSTABLE PISTONS - DELRIN - V3 | 338021 ALU SHOCK BODY (2) |
| 308040-0 SHOCK ADJ. NUT ALU + O-RING - ORANGE (4) | 338061 HARDENED SHOCK SHAFT (2) |
| 308081 SHOCK ABSORBER MEMBRANE - LOW (4) | 338185 SPRING-SET D=1.8 (33 LB) LIGHT-PURPLE - MEDIUM-MEDIUM HARD - FRONT (2) |
| 308091 SHOCK FOAM INSERTS - LOW (4) | 338296 SPRING-SET D=1.7 (28 LB) VIOLET - MEDIUM - REAR (2) |
| 308316 COMPOSITE SHOCK BALL JOINT - OPEN (4) | 965023 E-CLIP 2.3 (10) |
| 308327-0 ALU CAP FOR XRAY SHOCK BODY - ORANGE (2) | 970121 O-RING 12.1x1.6 (10) |
| 308331 COMPOSITE FRAME SHOCK PARTS 4-STEP - SHORT | 972030 SILICONE O-RING 3x2 (10) |
| 308352-0 ALU SHOCK CAP-NUT WITH HOLE - ORANGE (2) | |

965023
C2.3

4x

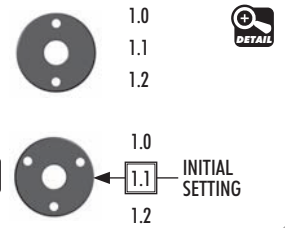
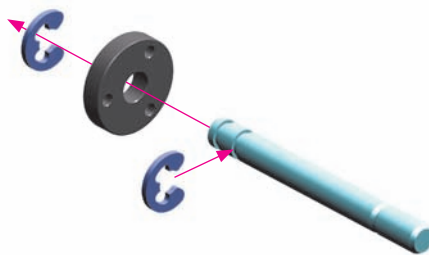

972030
O 3x2

4x

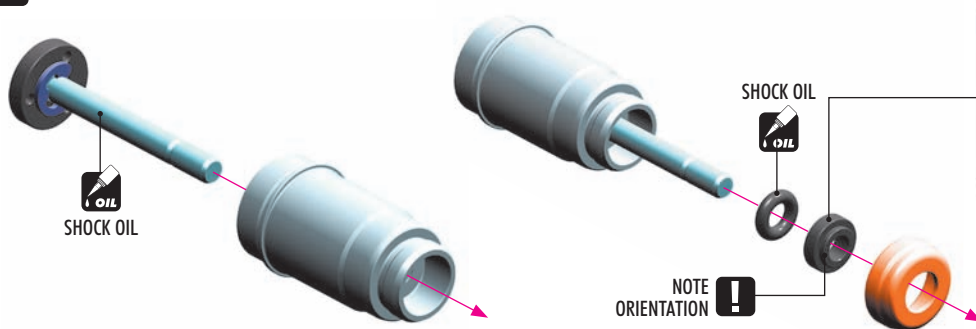

DO NOT USE CROSSED-OUT PARTS

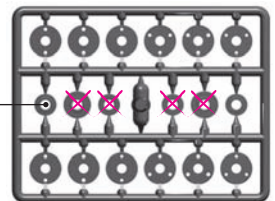



970121
0 12.1x1.6

4x

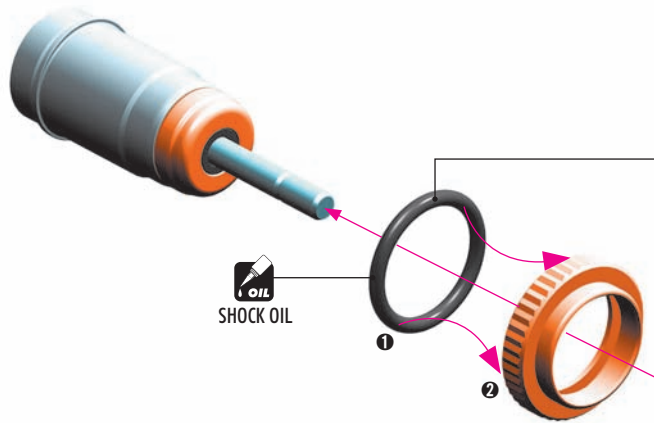

SHOCK OIL

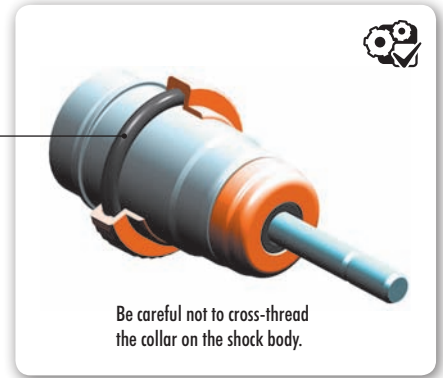

Be careful not to cross-thread the collar on the shock body.

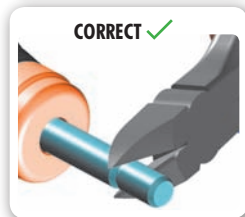
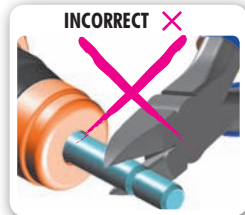

TIP Install the ball joint with Professional Multi Tool (HUDY #183011)

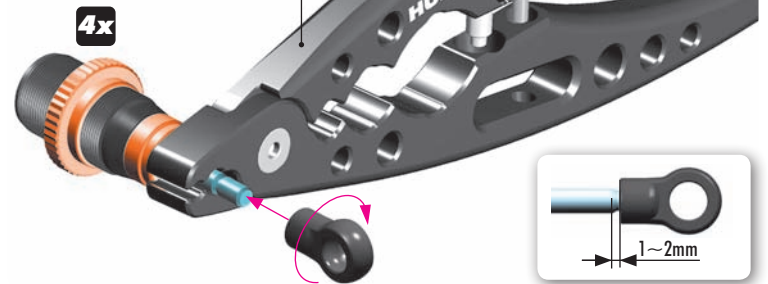

4x

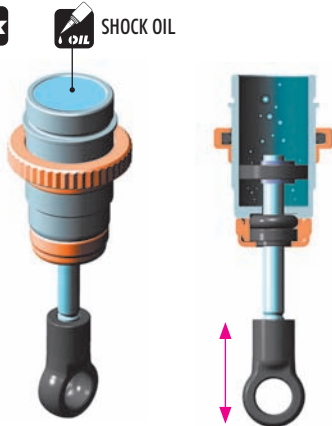

SHOCK FILLING

- 1 Fully extend the piston rod so the piston is at the bottom of the shock body.
- 2 Hold the shock upright and slightly overfill the shock body with shock oil.
- 3 Let the oil settle and allow air bubbles to rise to the top. Slowly move the piston up and down until no more air bubbles appear. Add shock oil as necessary.
- 4 Pull the piston rod most of the way out of the shock body. Let the shock rest for 5 minutes to allow the air bubbles to escape.

TIP #104002 HUDY AIR VAC – VACUUM PUMP - ON-ROAD

4x

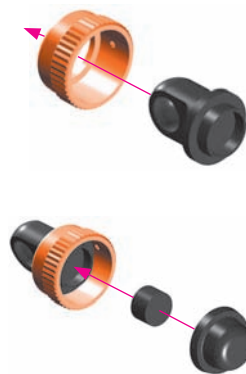

4x



CUTAWAY VIEW



After you insert the membrane ensure that it sits properly all around the alu cup properly.

When installing the shock cap assembly on the shock body, some oil will leak out... this is normal.

Fully tighten the cap and clean off any excess oil.

After the shock is assembled, the shock rod will push itself out of the shock body fairly quickly.

Follow the next procedure to adjust the rebound.

10. SHOCK ABSORBERS

4x

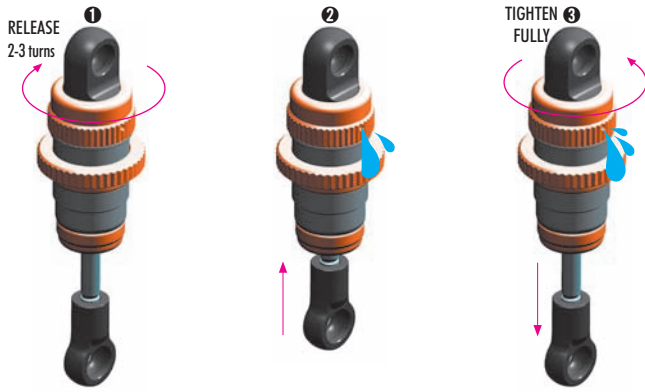

REBOUND ADJUSTMENT

AFTER THE SHOCK IS ASSEMBLED YOU HAVE TO SET THE SHOCK REBOUND.

- 1 Release the shock cap by 2-3 turns.
- 2 Push the shock shaft fully up. For the first time the extra oil will release through the hole in the alu cap-nut.
- 3 Tighten the shock cap. When tightening the shock cap, extra oil will again release through the hole in the alu cap - nut. When tightening, the shock shaft will push out from the shock body.

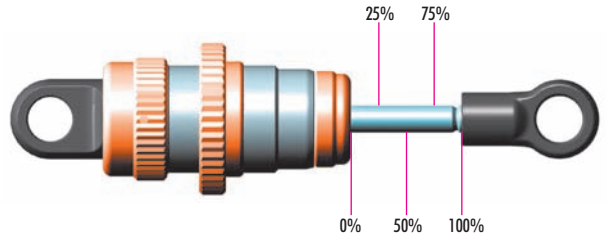

REBOUND CHECK

It is very important to push the shock shaft into the shock body slowly otherwise air can come into the shock body which would create bubbles.

- 100% rebound - repeat step 2 and 3 two - three times
- 75% rebound - repeat step 2 and 3 until the shock shaft will push out 75% of its length
- 50% rebound - repeat step 2 and 3 until the shock shaft will push out 50% of its length
- 25% rebound - repeat step 2 and 3 until the shock shaft will push out 25% of its length
- 0% rebound - repeat step 2 and 3 until the shock shaft will push out 0% of its length

If the shock shaft does not rebound enough, you will have to refill the shock with shock oil, and then repeat the bleeding and rebound adjustment procedure.

4x

SHOCK LENGTH ADJUSTMENT:

It is VERY important that all shocks are equal length.

Fully extend the shock absorber and measure the end-to-end length; we recommend using digital calipers to give an accurate measurement. If a shock absorber is shorter or longer than others, adjust the shock length by tightening or loosening the ball joint on the shock rod.

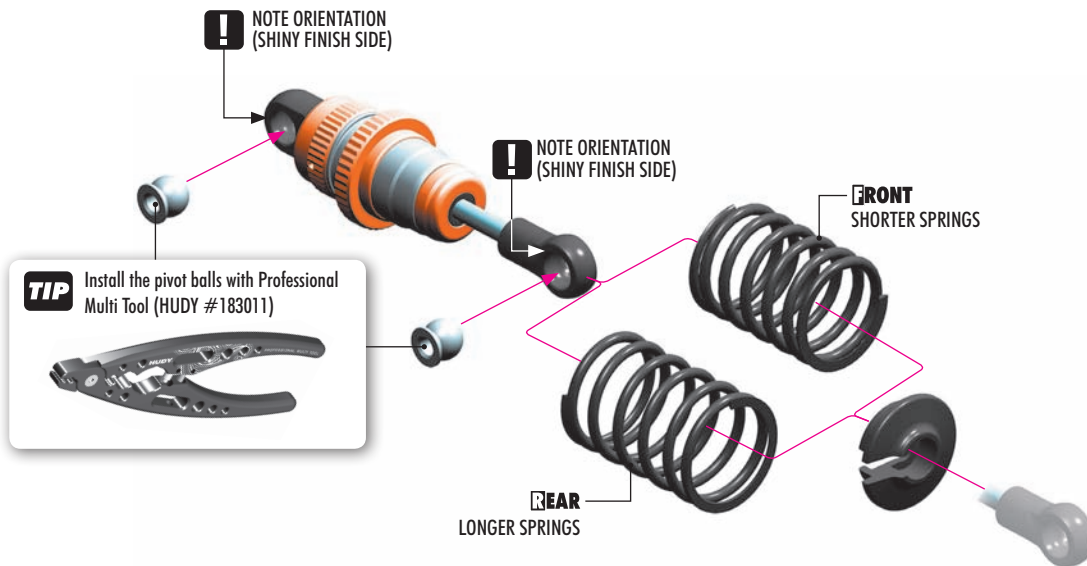

FRONT SPRINGS		
OPTION	338182	PROGRESSIVE C=4.0-5.6 OPTION
	338183	C=4.6 DARK-BLUE OPTION
	338184	C=5.0 VIOLET OPTION
	338185	C=5.4 LIGHT-PURPLE INCLUDED
	338186	C=5.8 PURPLE OPTION
	338187	C=6.3 LIGHT-RED OPTION



REAR SPRINGS		
OPTION	338281	PROGRESSIVE C=3.7-4.7 OPTION
	338286	C=3.6 DARK-BLUE OPTION
	338296	C=4.0 VIOLET INCLUDED
	338287	C=4.5 LIGHT-PURPLE OPTION
	338297	C=5.0 PURPLE OPTION
	338288	C=5.6 LIGHT-RED OPTION



#308031-0
ALU XRAY SHOCK SPRING RETAINING COLLAR - ORANGE (4)



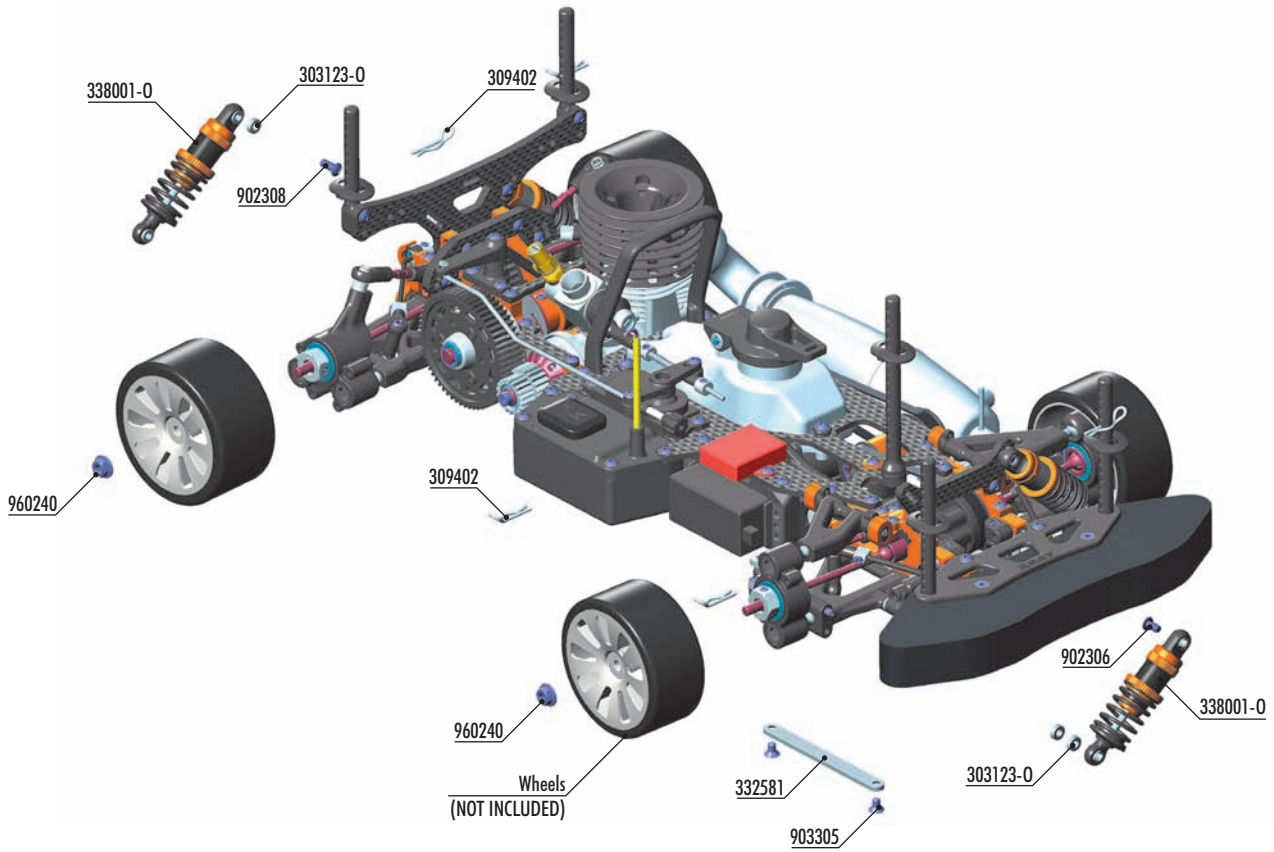

BAG

09

- 30 3123-0 ALU SHIM 3x6x2.0MM - ORANGE (10)
- 30 9402 BODY CLIP FOR 6MM BODY POST (4)
- 33 2581 ALU FRONT CHASSIS BRACE

- 90 2306 HEX SCREW SH M3x6 (10)
- 90 2308 HEX SCREW SH M3x8 (10)
- 90 3305 HEX SCREW SFH M3x5 (10)
- 96 0240 NUT M4 WITH SERRATED FLANGE (10)

- 33 8001-0 ALU SHOCK ABSORBER-SET - ORANGE (2)

10

303123-0
SHIM 3x6x2

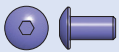

902306
SH M3x6

2x
L=R

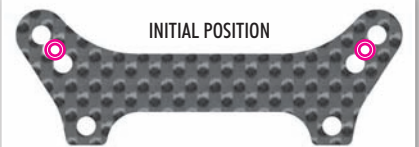
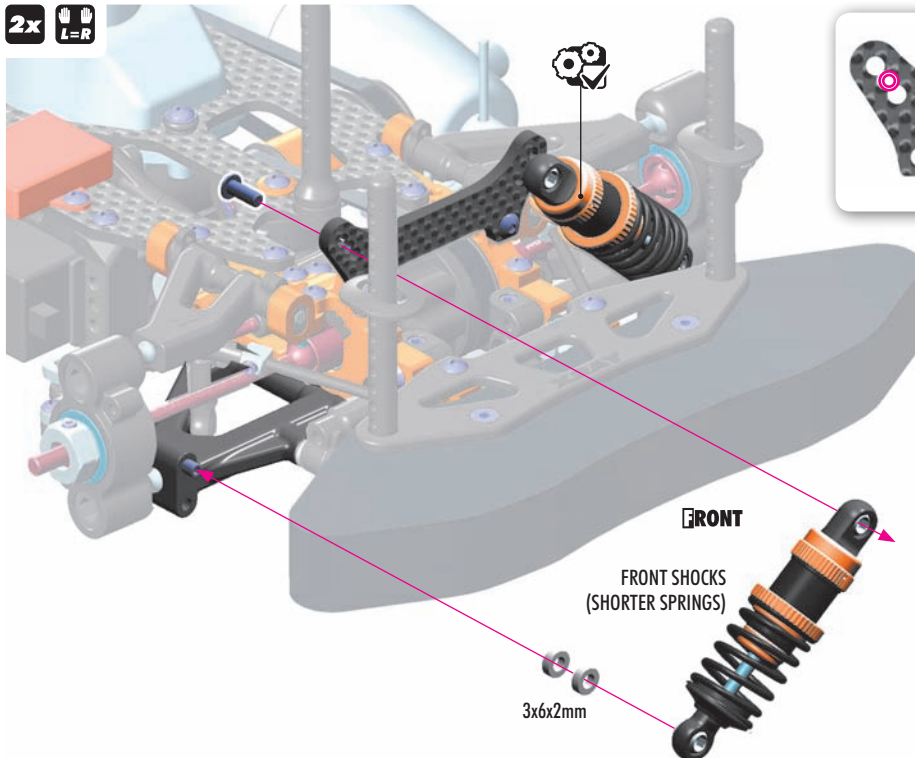

SET-UP
BOOK

SHOCK POSITION
ADJUSTMENT

FINAL ASSEMBLY

10
303123-0
SHIM 3x6x2



2x **L=R**

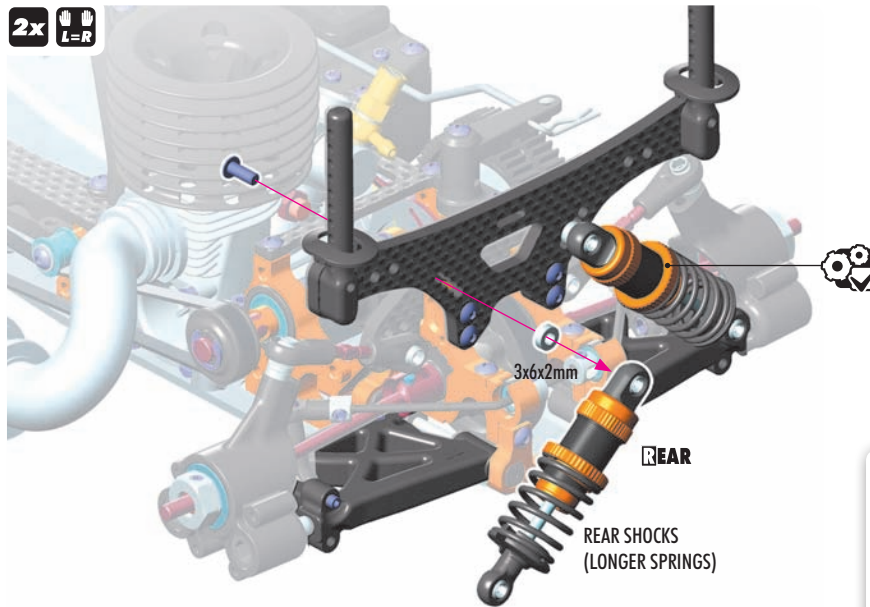

3x6x2mm

REAR

REAR SHOCKS
(LONGER SPRINGS)

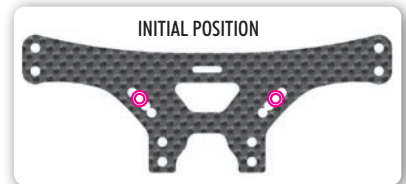

SHOCK POSITION
ADJUSTMENT



903305
SFH M3x5

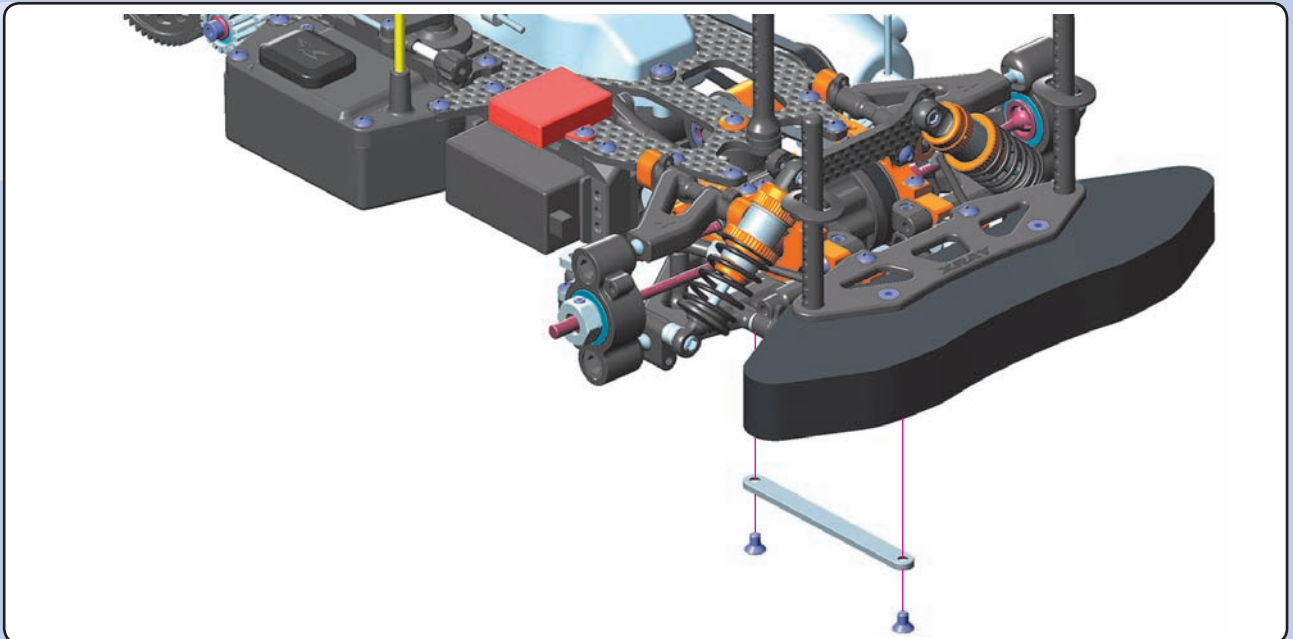

960240
N M4

4x **L=R**

! TIRES NOT INCLUDED

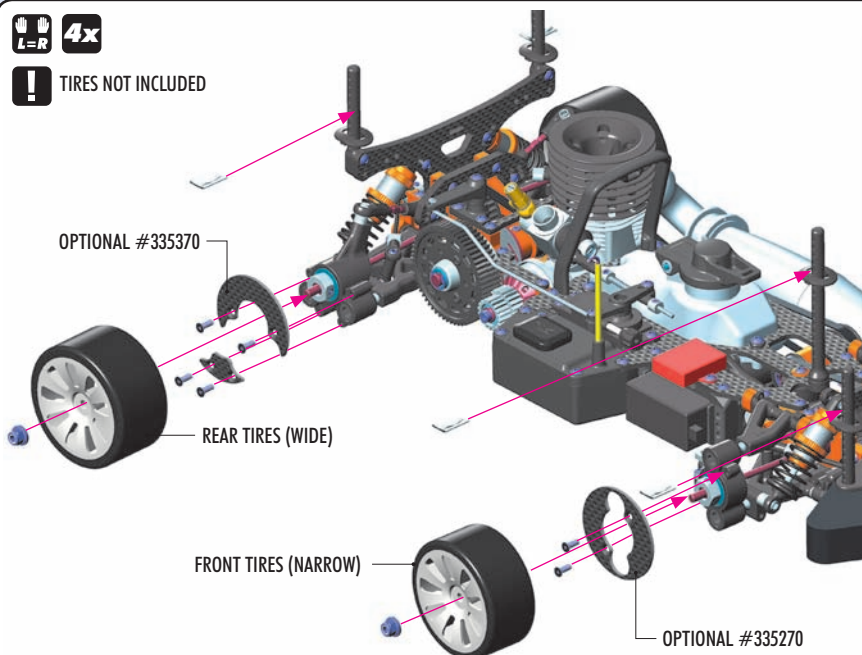

OPTIONAL #335370

REAR TIRES (WIDE)

FRONT TIRES (NARROW)

OPTIONAL #335270



#335270

GRAPHITE AERODYNAMIC DISK - FRONT
OPTION for improved steering



#335370

GRAPHITE AERODYNAMIC DISK - REAR
OPTION for improved stability and traction



REAR

FRONT

Cut 2 pieces of silicone tubing and install as follows: **SILICONE TUBING MARKED AS RED**
muffler to fuel tank cap

SILICONE TUBING MARKED AS BLUE
fuel tank to carburetor

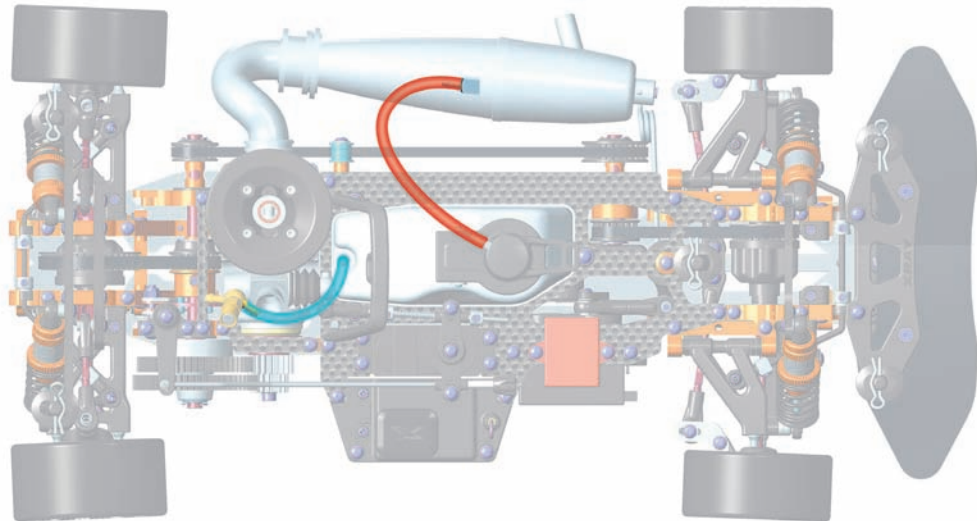

CARB LINKAGE ADJUSTMENT

NEUTRAL (IDLE)

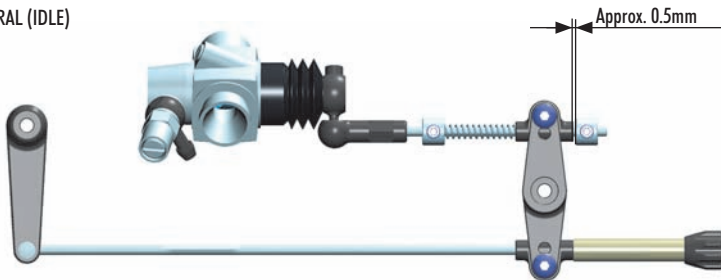

IDLE ADJUSTMENT SCREW

Do not allow carburetor to close to less than **0.5mm**.

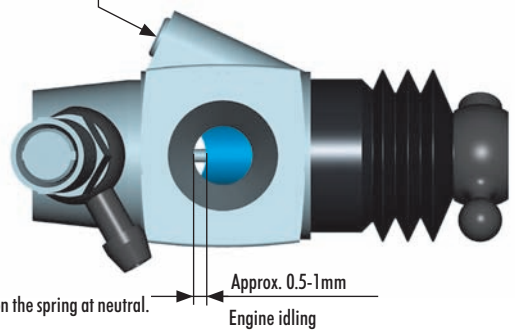

Turn on transmitter and receiver and set the throttle servo trim to the neutral position.
Adjust the idle adjustment screw on the carburetor to open approx. 0.5-1mm.
Adjust both collars on the carb and brake linkages accordingly. The carb linkage must have approximately 0.5mm of preload on the spring at neutral.
DO NOT ADJUST while the engine is running.

FULL THROTTLE

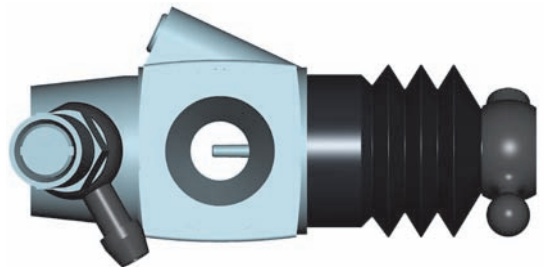
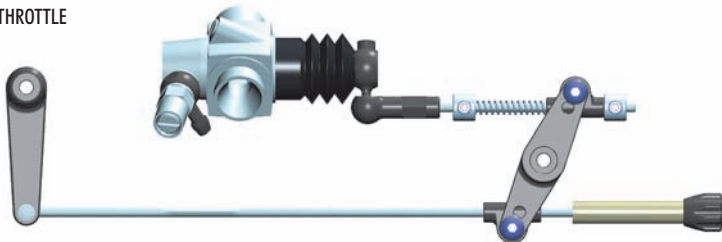

With the engine **NOT RUNNING** but the receiver turned ON, apply full throttle at the transmitter.

Adjust the transmitter's throttle servo high-end point so that the servo horn fully opens the carburetor when the transmitter's throttle control (e.g., throttle trigger) is at 95% of full throttle. The servo should not have excessive strain when at full throttle, or throttle/carb damage will result.

If the transmitter does not have throttle high-end point adjustment, adjust the throttle linkage pivot position on the servo horn until full throttle is obtained.

BRAKE

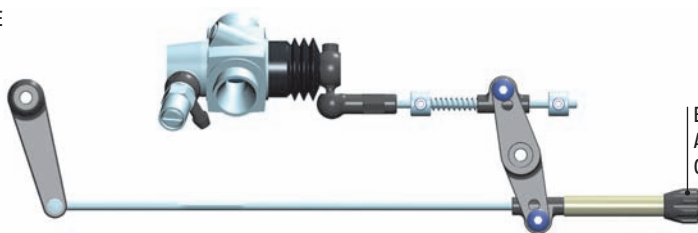

BRAKE ADJUSTING COLLAR

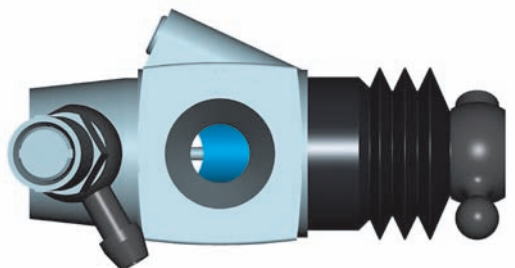

Adjust the composite collar on the brake linkage so the brakes work smoothly.

If the brakes apply too much or not enough, adjust the collar accordingly. If your transmitter has throttle servo low-end point adjustment (or brake adjustment), use that to set the appropriate amount of throttle servo horn throw.

www.teamxray.com

XRAY EUROPE

XRAY, K VÝSTAVISKU 6992, 91101 TRENCIN, SLOVAKIA, EUROPE
PHONE: +421-32-740 11 00, FAX: +421-32-740 11 09, info@teamxray.com

XRAY USA

RC AMERICA, 2030 Century Center Blvd #15, Irving, TX 75062, USA
PHONE: 214-744-2400, FAX: 214-744-2401, xray@rcamerica.com



[/TeamXray](#)



[/TeamXray](#)



[/TeamXray](#)



[/XrayRacing](#)



[/+TeamXrayRC](#)