

NOTICE

TH =Apply Thread Lock Adhesive
=使用螺絲防鬆膠

CA =Apply CA Glue
=使用瞬間接著劑

GE =Apply Grease
=使用潤滑油

BAG 01

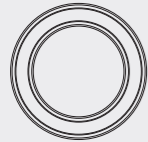

R806020
12x18x4mm Ball Bearing (4)

1:1 Scale

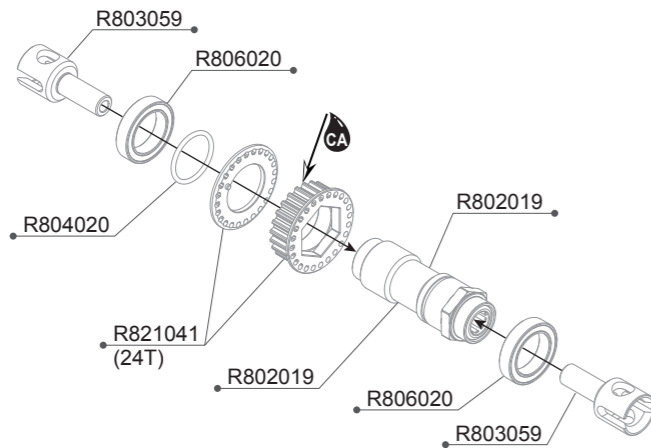

Finished View / 完成圖

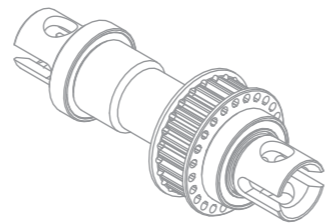

R802019 Front One Way
R803059 Front One Way Cup (2)
R804020 O'Ring 10x1.5 (6)

R806020 12x18x4 Ball Bearing (4)
R821041 R8.3 Front Pulley Set

BAG 01



R105203
3x6mm Flat Screw (10)



R805052
4x8mm Set Screw (10)

1:1 Scale

Right Side Bulkhead (右邊側板)

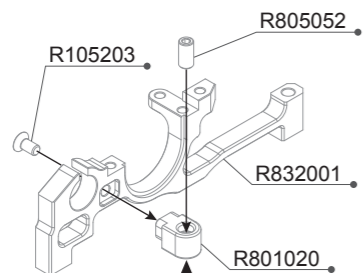

Left Side Bulkhead (左邊側板)

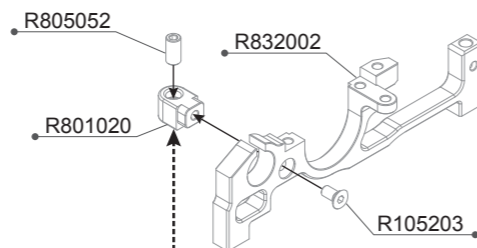

Option Parts (Not Included) / 改裝品 (未附於套件內)

R813005 Downstop Adjust Screw (4)



R105203 3x6mm Flat Screw (10)
R801020 Downstop Nut Holder (2)
R805052 4x8mm Set Screw (10)

R832001 R8.3 Front Low Bulkhead-R
R832002 R8.3 Front Low Bulkhead-L

BAG 01

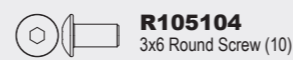

R105104
3x6 Round Screw (10)



R805201
4x8mm Flat Screw (10)

1:1 Scale

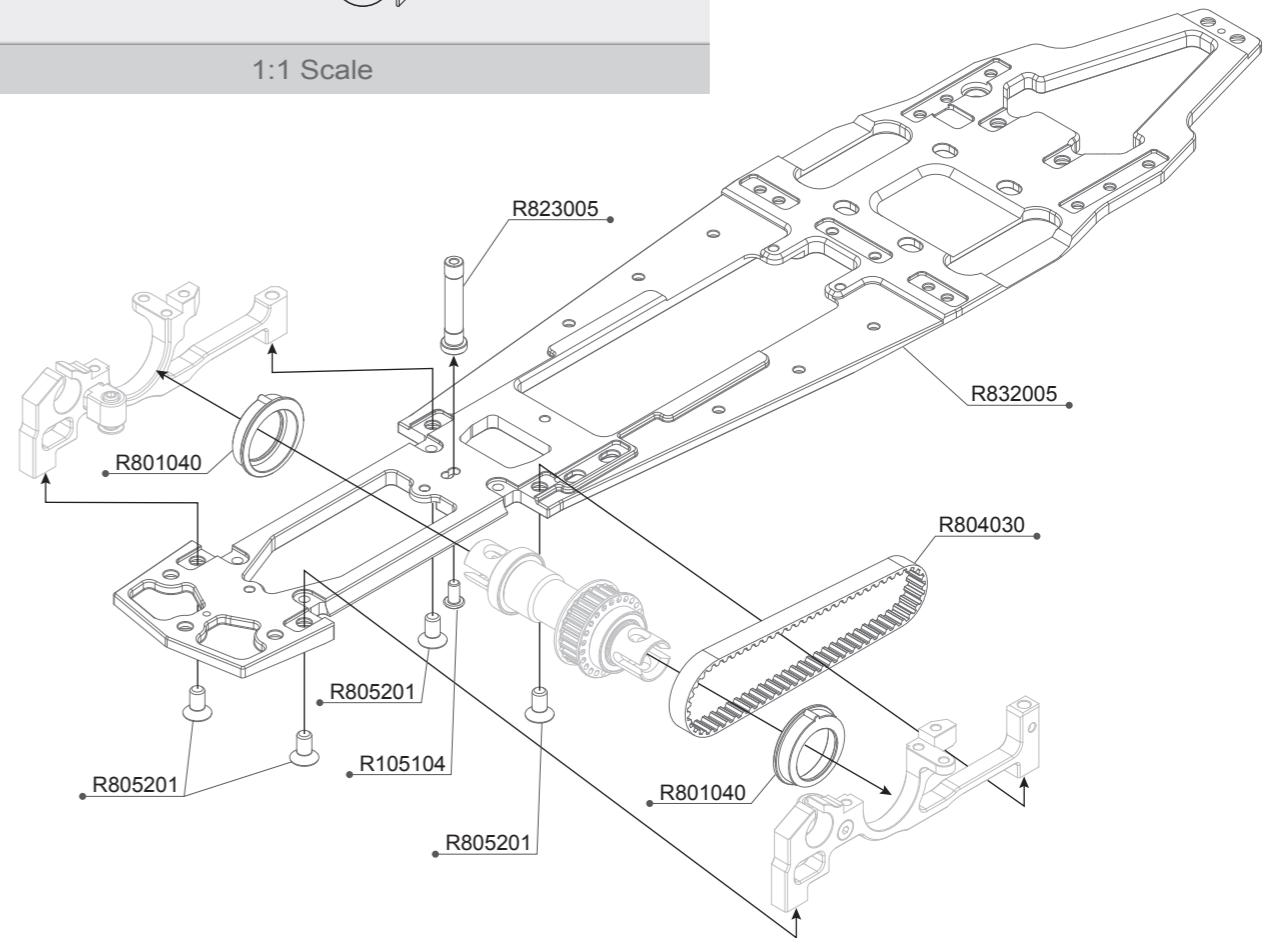

R105104 3x6 Round Screw (10)
R801040 Bearing Bushing -Solid Axle (2)
R804030 Front Belt 201

R805201 4x8mm Flat Screw (10)
R823005 R8.2 LCG Sever Saver Post
R832005 R8.3 Main Chassis 7075-Alu

BAG 01

Option Parts (Not Included) / 改裝品 (未附於套件內)

R838008 R8.3 Chassis Cover Front-Carbon

The chassis cover is design to reduce the turbulence and flexibility in the front end, it will increase stability and make car more easy to drive especially in the high traction track.

R8.3 專用的前底盤下蓋，這個下蓋可以有效的降低底盤的亂流並增加底盤的剛性，適合使用在高抓地力的跑道，安裝後可以使車輛更安定更容易駕駛。

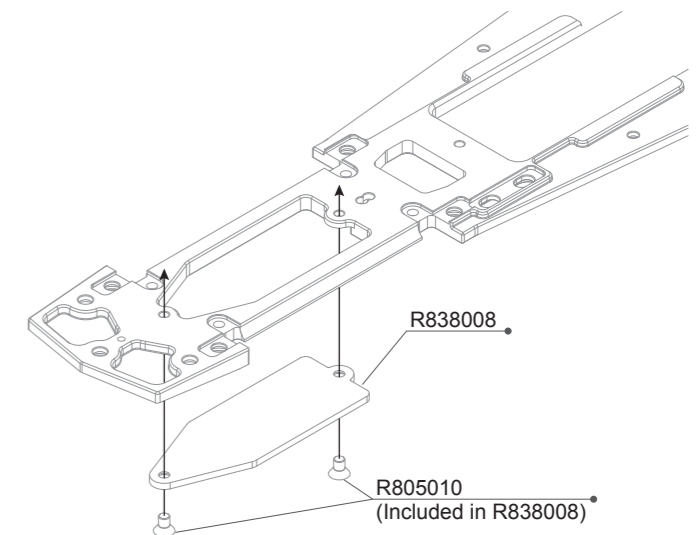

- R805101**
4x6 Round Screw (10)
- R805045**
E-Clip 5mm (6)
- R806006**
6x13x5mm
Ball Bearing (2)
- R806100**
Ø2.5x11.8 Pin (6)

1:1 Scale

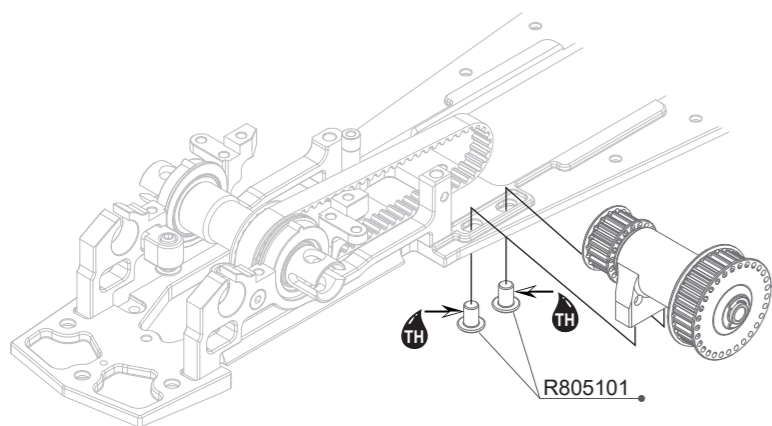
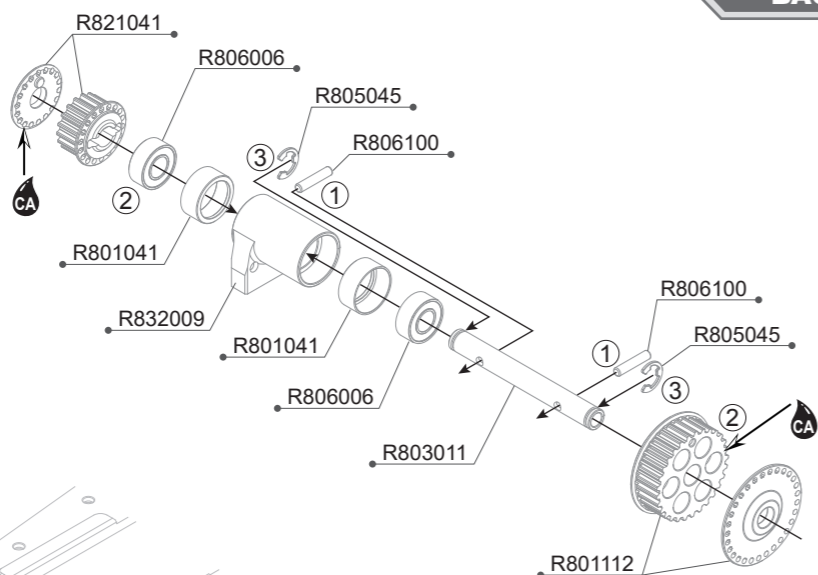

- R801041 Bearing Bushing -Middle Shaft (2)
- R801112 Pulley Set -Middle
- R803011 Middle Shaft
- R805101 4x6 Round Screw (10)
- R805045 E-Clip 5mm (6)

- R806006 6x13x5 Ball Bearing (2)
- R806100 Pin 2.5x11.8 (6)
- R821041 R8.3 Front Pulley Set
- R832009 R8.3 Middle Shaft Base-Alu

- R105104**
3x6 Round Screw (10)
- R105105**
3x8 Round Screw (10)

1:1 Scale

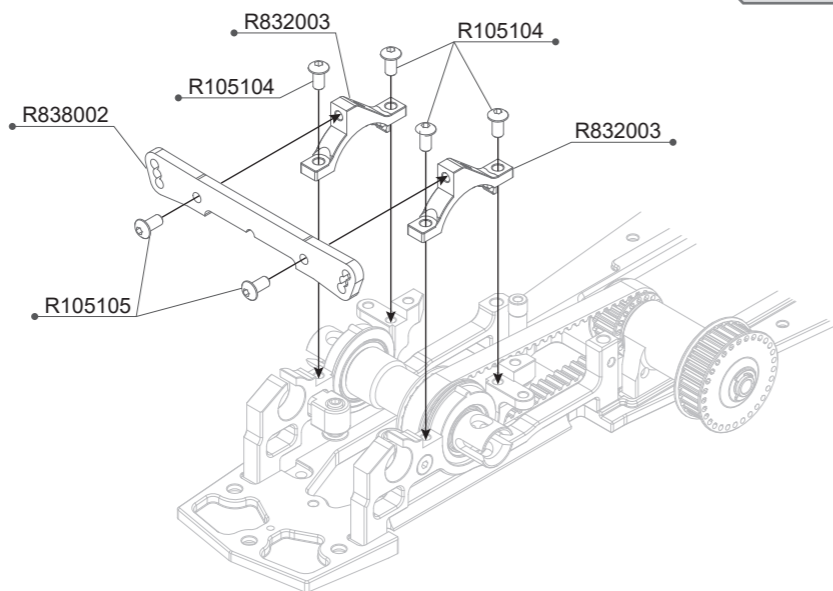

- R105104 3x6 Round Screw (10)
- R105105 3x8 Round Screw (10)

- R832003 R8.3 Front Upper Bulkhead
- R838002 R8.3 Front Shock Tower

NOTICE

Please set the front belt tension as below in the beginning, to loosen the belt please turn left, to tighten the belt please turn right.
前皮帶的張力請依下方圖示設定於起始的位置，如需將皮帶張力調鬆時請依圖示向左調整，如需調緊時請向右調整。

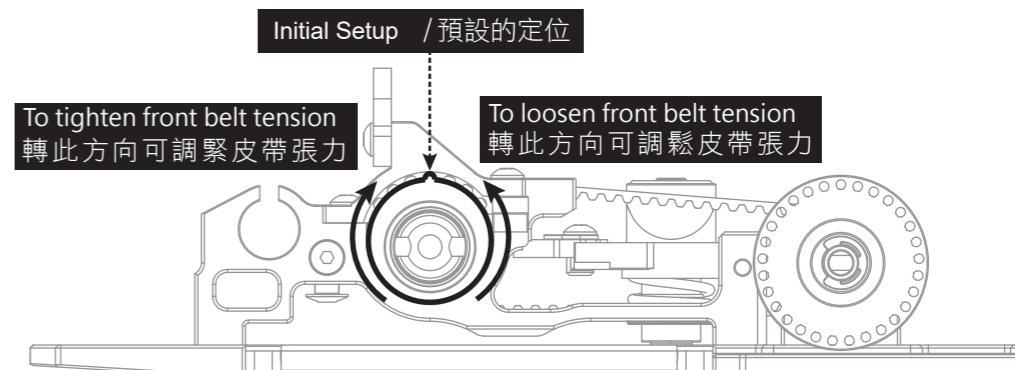

- R105104**
3x6 Round Screw (10)

- R106010**
5x8x2.5mm Ball Bearing (4)

1:1 Scale

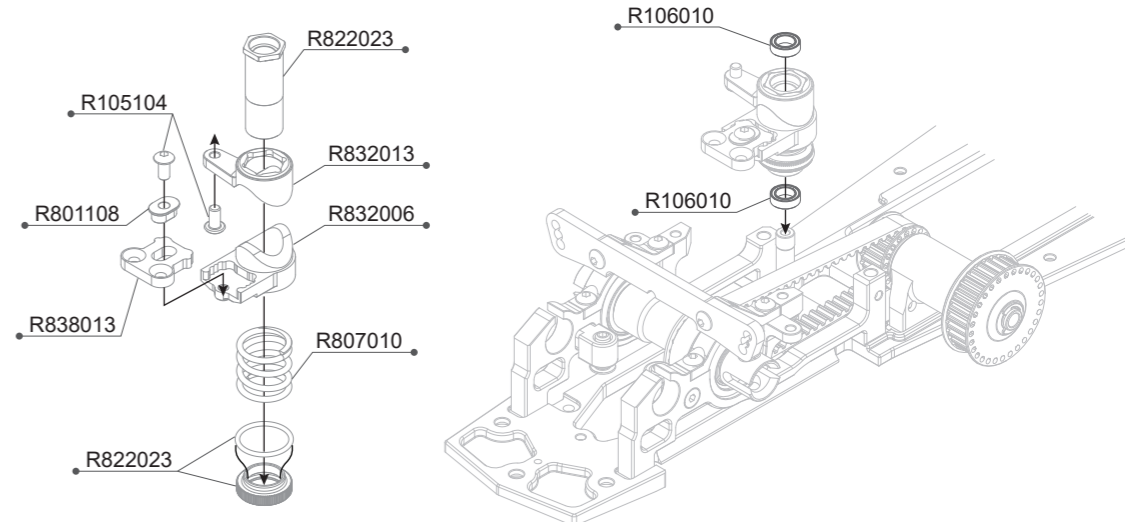

NOTICE

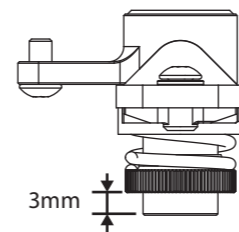

DEFAULT DISTANCE
預設的位置

NOTICE

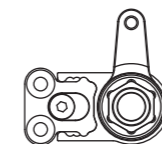

When track has "High Traction" or want to reduce steering.
此設定建議使用在高抓地力的跑道或是需要降低車輛轉向的反應時。

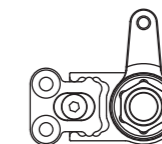

DEFAULT SETUP
預設的中性設定

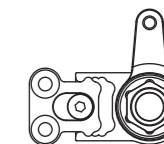

When track has "Low Traction" or want to increase steering
此設定建議使用在低抓地力的跑道或是需要增加車輛初期的轉向反應時。

- R105104 3x6 Round Screw (10)
- R106010 5x8x2.5mm Ball Bearing (4pcs)
- R801108 Ackerman Adjustment Shims 0/+1.5
- R807010 Servo Saver Spring

- R832013 R8.3 Servo Saver Upper
- R822023 R8.2 LCG Sever Saver Tower
- R832006 R8.3 Servo Saver Lower
- R838013 R8.3 Ackerman Plate 10mm

R8.3 BAG 01 PARTS EXPLORE VIEW

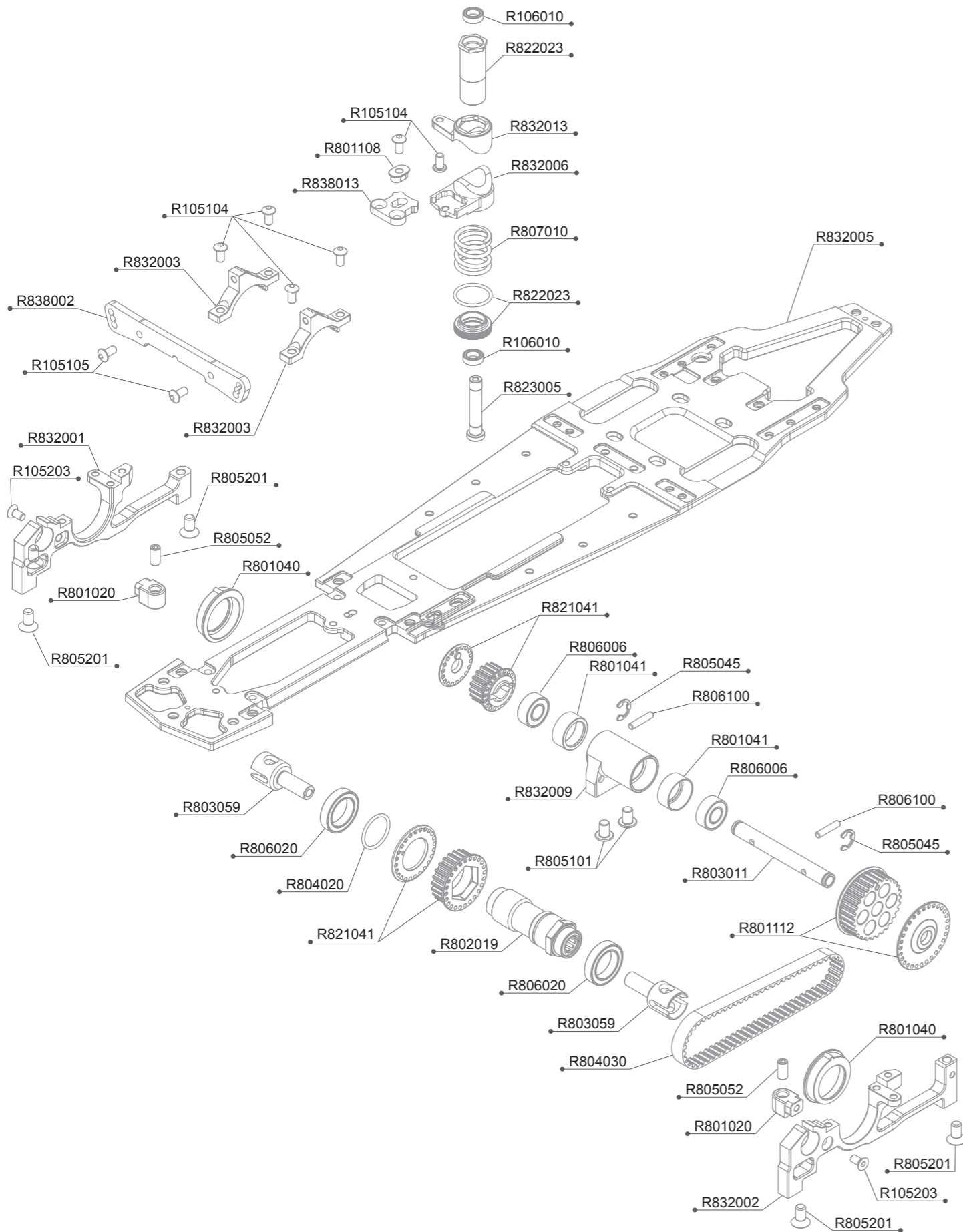

R8.3 BAG 01 PARTS LIST

R105104	3x6 Round Screw (10)	R805201	4x8mm Flat Screw (10)
R105105	3x8 Round Screw (10)	R806006	6x13x5 Ball Bearing (2)
R105203	3x6mm Flat Screw (10)	R806020	12x18x4 Ball Bearing (4)
R106010	5x8x2.5mm Ball Bearing (4pcs)	R806100	Pin 2.5x11.8 (6)
R801020	Downstop Nut Holder (2)	R807010	Servo Saver Spring
R801040	Bearing Bushing -Solid Axle (2)	R821041	R8.3 Front Pulley Set
R801041	Bearing Bushing -Middle Shaft (2)	R822023	R8.2 LCG Sever Saver Tower
R801108	Ackerman Adjustment Shims 0/+1.5	R823005	R8.2 LCG Sever Saver Post
R801112	Pulley Set -Middle	R832001	R8.3 Front Low Bulkhead-R
R802019	Front One Way	R832002	R8.3 Front Low Bulkhead-L
R803011	Middle Shaft	R832003	R8.3 Front Upper Bulkhead
R803059	Front One Way Cup (2)	R832005	R8.3 Main Chassis 7075-Alu
R804020	O'Ring 10x1.5 (6)	R832006	R8.3 Servo Saver Lower
R804030	Front Belt 201	R832009	R8.3 Middle Shaft Base-Alu
R805045	E-Clip 5mm (6)	R832013	R8.3 Servo Saver Upper
R805052	4x8mm Set Screw (10)	R838002	R8.3 Front Shock Tower
R805101	4x6 Round Screw (10)	R838013	R8.3 Ackerman Plate 10mm

1:1 SCALE

	R105104 3x6 Round Screw (10)		R106010 5x8x2.5mm Ball Bearing (4)
	R105105 3x8 Round Screw (10)		R806006 6x13x5mm Ball Bearing (2)
	R805101 4x6 Round Screw (10)		R806020 12x18x4mm Ball Bearing (4)
	R105203 3x6mm Flat Screw (10)		R805052 4x8mm Set Screw (10)
	R805201 4x8mm Flat Screw (10)		R806100 Ø2.5x11.8 Pin (6)
	R805045 E-Clip 5mm (6)		



R105101
2x5mm Cap Screw (10)



R105204
3x8mm Flat Screw (10)



R105104
3x6 Round Screw (10)



R105105
3x8 Round Screw (10)

1:1 Scale

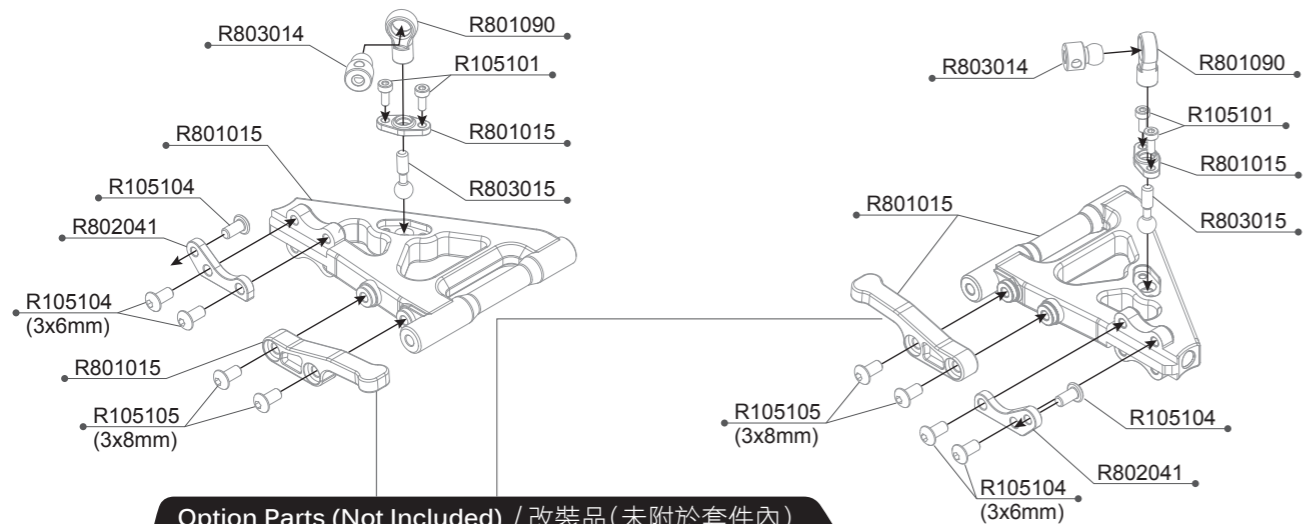

Option Parts (Not Included) / 改裝品 (未附於套件內)

R802087

Front Down Stop Arm-Alu (2)



The option aluminum arm helps to make droop setup more precise.
鋁合金製作的下抬行程控制臂可以更精確的去控制與設定下抬量的行程。

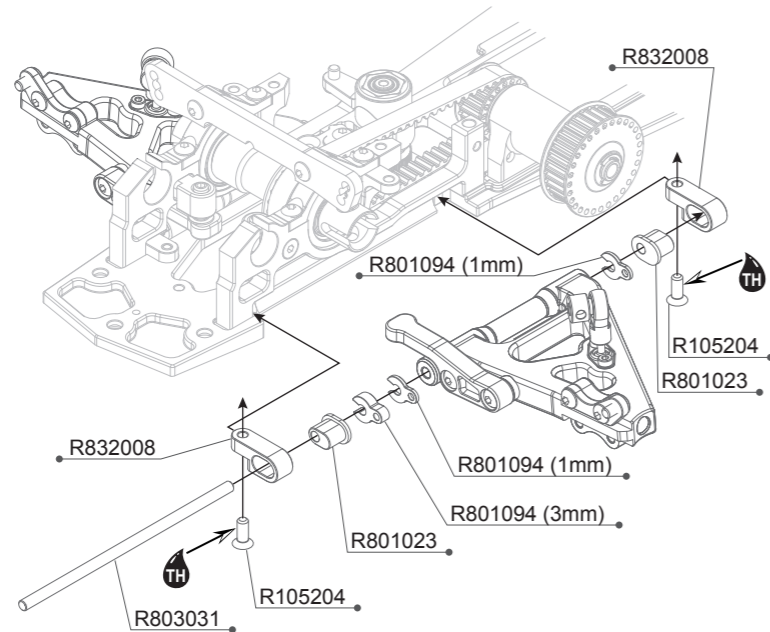

- | | | | |
|---------|------------------------------------|---------|-------------------------------|
| R105101 | 2x5mm Cap Screw (10) | R801094 | C Spacer Set 1mm/2mm/3mm |
| R105104 | 3x6 Round Screw (10) | R802041 | Front Shock Mount S (2) |
| R105105 | 3x8 Round Screw (10) | R803014 | Anti Roll Bar Ball Head (2) |
| R105204 | 3x8mm Flat Screw (10) | R803015 | Anti Roll Bar Screw (2) |
| R801015 | Front Low Arm Set | R803031 | Front Low Arm Pin 3x77.8 |
| R801023 | Suspension Bracket Insert-Open (8) | R832008 | R8.3 Front Low Arm Holder (2) |
| R801090 | Ball End 5.8mm (4) | | |

R8.3 FRONT LOW ARM SETUP / R8.3前下擺臂設定表

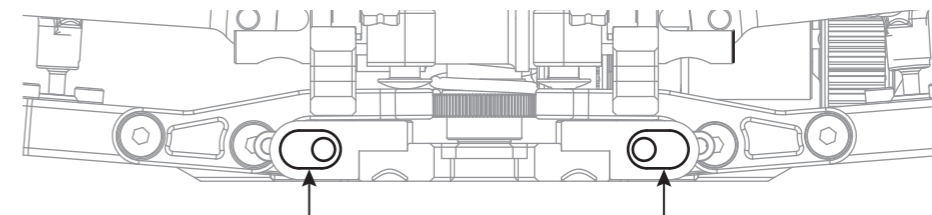

- Move the insert hole to outside and front low arm will become shortest, shorter front low arm will help to increase initial steering response and avoid over steering, recommend using in very short and tight corner with medium traction.
孔位朝外時前下擺臂長度變成最短，較短的前下擺臂可以有效的增加轉向的初期反應，並防減少車輛轉向過度，建議使用在較小與多彎的跑道上。
- Move the insert hole to center and the low arm length extend 1.5mm compare with shortest arm, it will help to reduce the steering response and increase exit corner steering, recommend using in the medium size track and corner.
將孔位放置於中間時前下擺臂的長度相較於最短的設定增加1.5mm，此設定可減少車輛轉向的初期反應，並增加出彎時的轉向能力，適合在中型跑道上。
- Default setup** is move the insert hole to inside and make low arm become longest, the longest arm will reduce the initial steering response and make car more easy to drive also increase the exit corner and on-power steering.
預設的位置是將孔位放置在最內的位置，此時前下擺臂的長度是最長的，較長的前下擺臂可以減少轉向初期的反應使車輛比較容易駕駛並有效的增加出彎與加油門時車輛的轉向能力。



R105401
3x3mm Set Screw (10)



R806005
5x10x4mm
Flange Ball Bearing (2)

1:1 Scale

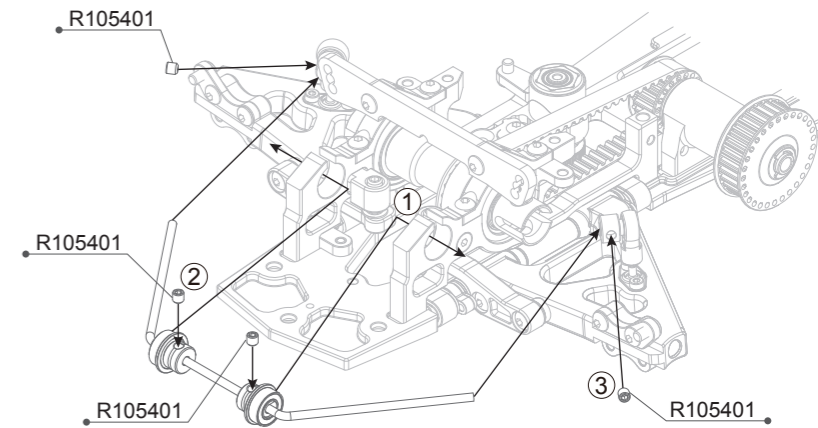
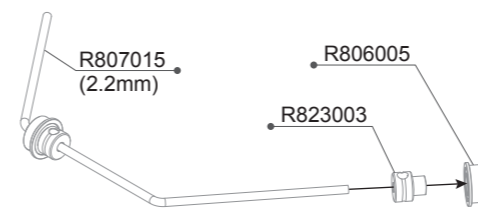

Option Parts (Not Included) / 改裝品 (未附於套件內)

- | | | | |
|----------------|---------------------------|----------------|---------------------------|
| R807014 | Front Anti-Roll Bar 2.0mm | R807017 | Front Anti-Roll Bar 2.6mm |
| R807016 | Front Anti-Roll Bar 2.4mm | R807018 | Front Anti-Roll Bar 2.8mm |





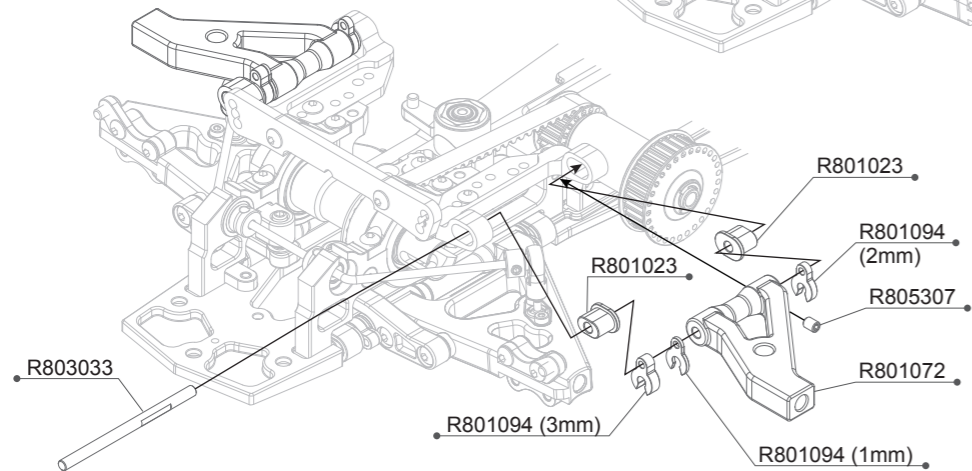
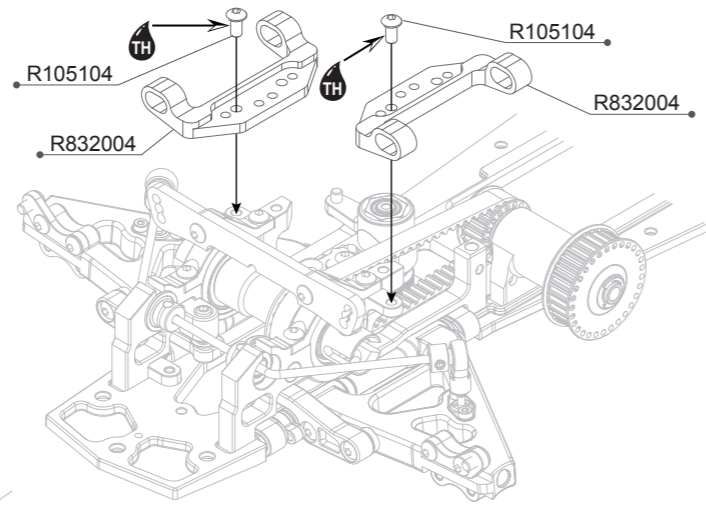

- | | | | |
|---------|--------------------------------|---------|-----------------------------------|
| R105401 | 3x3mm Set Screw (10) | R807015 | Front Anti-Roll Bar 2.2mm |
| R806005 | 5x10x4 Flange Ball Bearing (2) | R823003 | Anti-Roll Bar Stopper 2.0-2.4 (2) |

-  **RR805307**
3x6mm Set Screw (10)
-  **R105104**
3x6 Round Screw (10)

1:1 Scale





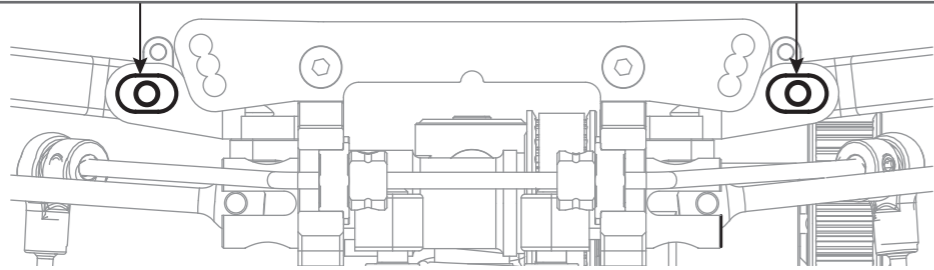

R8.3 FRONT UPPER ARM SETUP/ R8.3前上擺臂設定表

	Move the insert hole to outside and front upper arm will become shortest, it will increase initial steering response and reduce exit and on-power steering. 將孔位朝向外，前上擺臂的長度會變成是最短的設定，此設定可以增加轉向的初期反應，但會減少車輛出彎與加油門時的轉向總量。	
	Default setup is put the hole in middle and the car will become natural steering. 預設的位置孔位放置於中間，此設定會使車輛的整體的轉向比較中性。	
	Move the insert hole to inside and front upper arm will become longest, it will reduce the initial steering response and increase exit and on-power steering. 將孔位朝內，前上擺臂的長度會變成是最長的設定，此設定可以減少轉向的初期反應，但會增加車輛出彎與加油門時的轉向能力。	

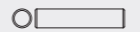

- | | | | |
|---------|------------------------------------|---------|---------------------------|
| R105104 | 3x6 Round Screw (10) | R803033 | Front Upper Arm Pin 3x49 |
| R801023 | Suspension Bracket Insert-Open (8) | R805307 | 3x6mm Set Screw (10) |
| R801072 | Front Upper Arm (2) | R832004 | R8.3 Front Upper Arm Base |
| R801094 | C Spacer Set 1mm/2mm/3mm | | |

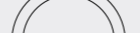
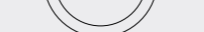
-  **R105401**
3x3mm Set Screw (10)
-  **R105105**
3x8 Round Screw (10)
-  **R806100**
Ø2.5x11.8 Pin (6)
-  **R806101**
Ø3x19.8 Pin (6)
-  **R803051**
12.1x15x0.5mm Shims (10)
-  **R806021**
12x21x5mm Ball Bearing (2)

1:1 Scale

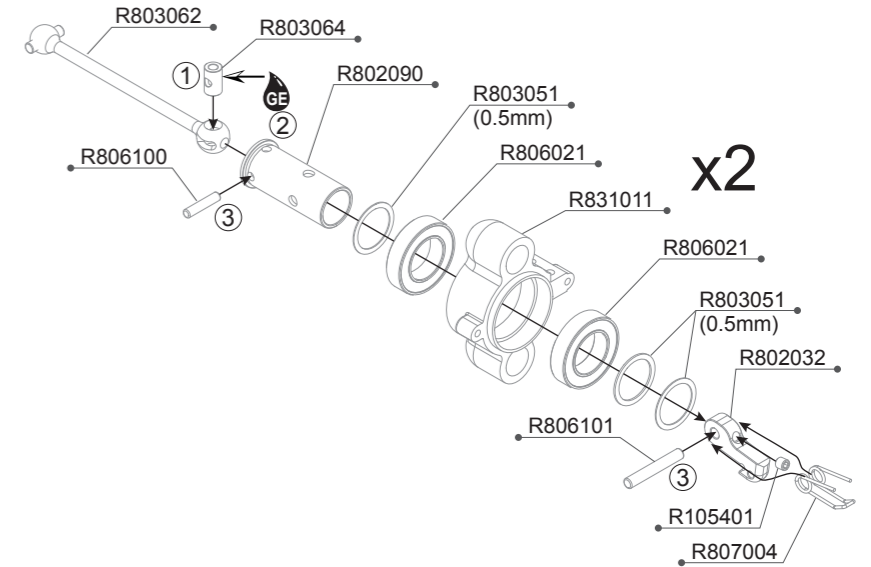

Option Parts (Not Included) / 改裝品 (未附於套件內)

R832012 R8.3 Offset Axle Insert (4)

The offset insert will move the front wheel axle backward, it will help to increase on-power steering, recommend to use in medium or low traction track. 偏心的輪軸墊片可將前輪軸向後移，當賽道的抓地力不足或需要更多的轉向時可選用。

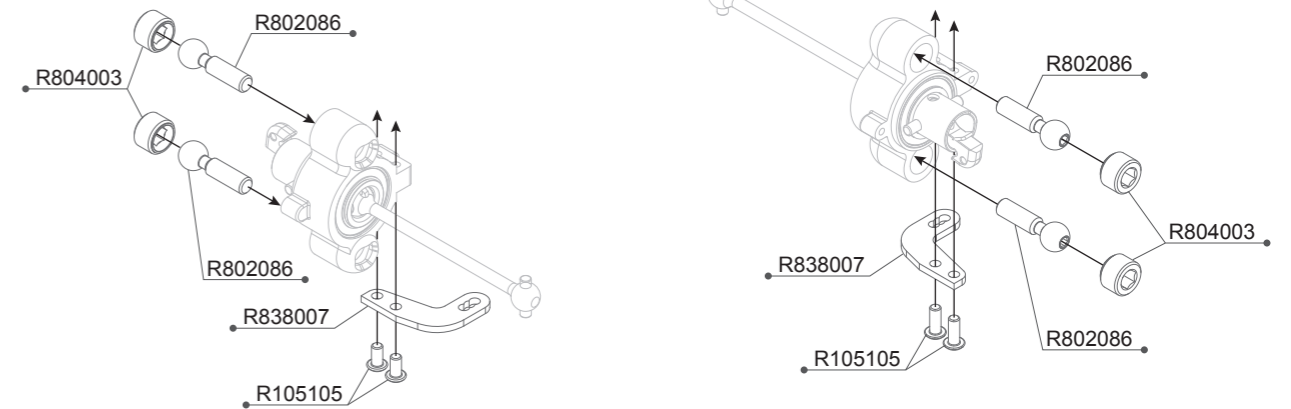
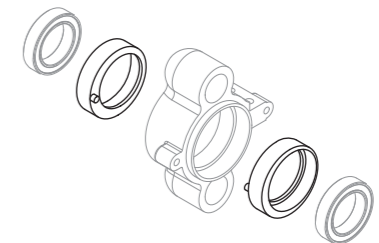

- | | | | |
|---------|-----------------------------|---------|----------------------------|
| R105401 | 3x3mm Set Screw (10) | R804003 | 7.9mm Ball End Nut (4) |
| R105105 | 3x8 Round Screw (10) | R806021 | 12x21x5mm Ball Bearing (2) |
| R802032 | Front Tire Hook (2) | R806100 | Pin 2.5x11.8 (6) |
| R802086 | 7.9mm Ball End Long-Alu (4) | R806101 | Pin 3x19.8 (6) |
| R802090 | Front Wheel Axle - Alu (2) | R807004 | Tire Hook Spring (4) |
| R803051 | 12.1x15x0.5mm Shims (10) | R831011 | R8.3 Steering Block |
| R803062 | Front CVD Shaft (2) | R838007 | R8.3 Steering Plate (2) |
| R803064 | CVD Insert (2) | | |

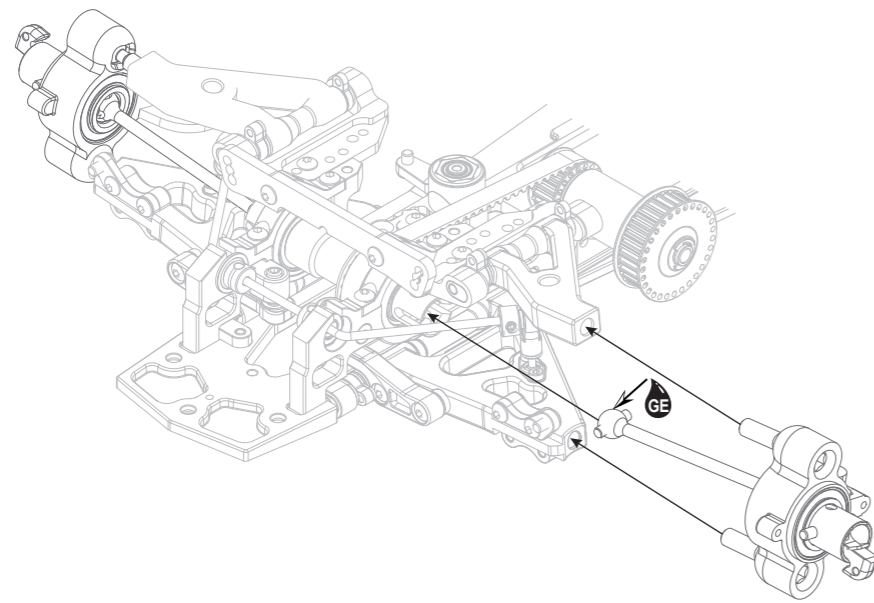

NOTICE
Front upper arm width setup (UP View)
 前上擺臂寬度的設定 (上視圖)

Front track width 252mm / 預設前車寬252mm

3.5mm

NOTICE
Front low arm width setup (Down View)
 前下擺臂寬度的設定 (下視圖)

Front track width 252mm / 預設前車寬252mm



3.5mm

Recommend Tool / 建議使用工具
 TITAN #15006
 Turnbuckle Tool 3mm/4mm

NOTICE

45 mm

- R10107A Ball Joint 4.9mm Open (6pcs)
- R803016 Ball Head 4.9mm (4)
- R803035 3mm X 62mm Rod (2)

-  **R105105**
3x8 Round Screw (10)
 -  **R805010**
3x5mm Flat Screw (10)
- 1:1 Scale

NOTICE

Default Position
 預設的孔位

Same length
 雙邊等長

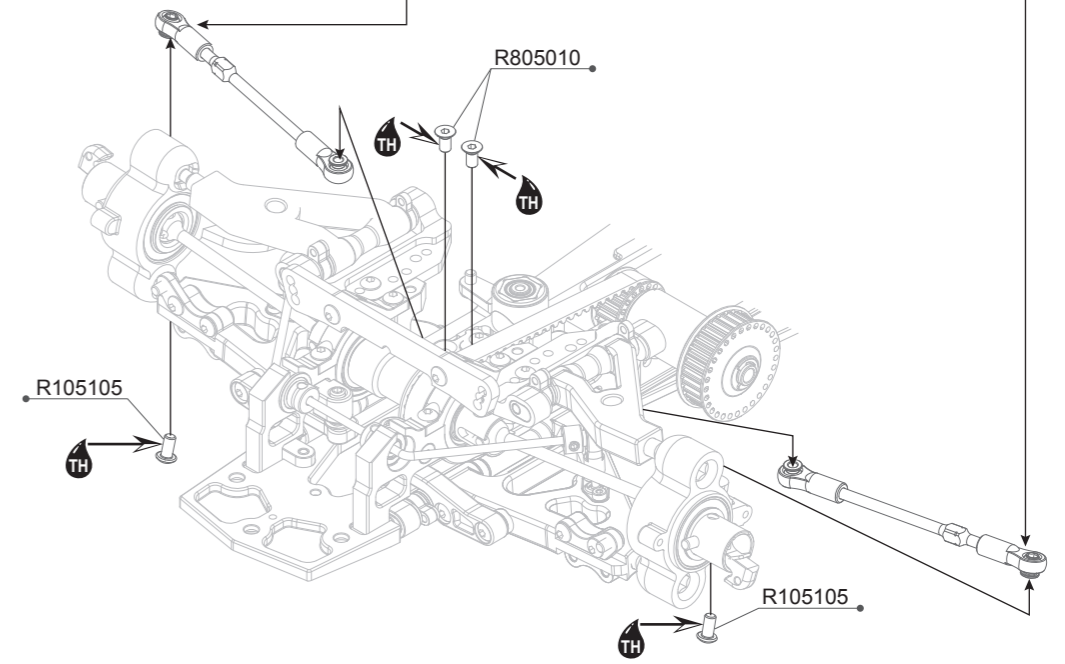

NOTICE
Initial front droop setup / 前下擺臂寬度的設定

0mm

Please setup the front droop as above instruction.
 請依圖示設定前下抬量的位置。

- R105105 3x8 Round Screw (10)
- R805010 3x5mm Flat Screw (10)

R8.3 BAG 02 PARTS EXPLORE VIEW

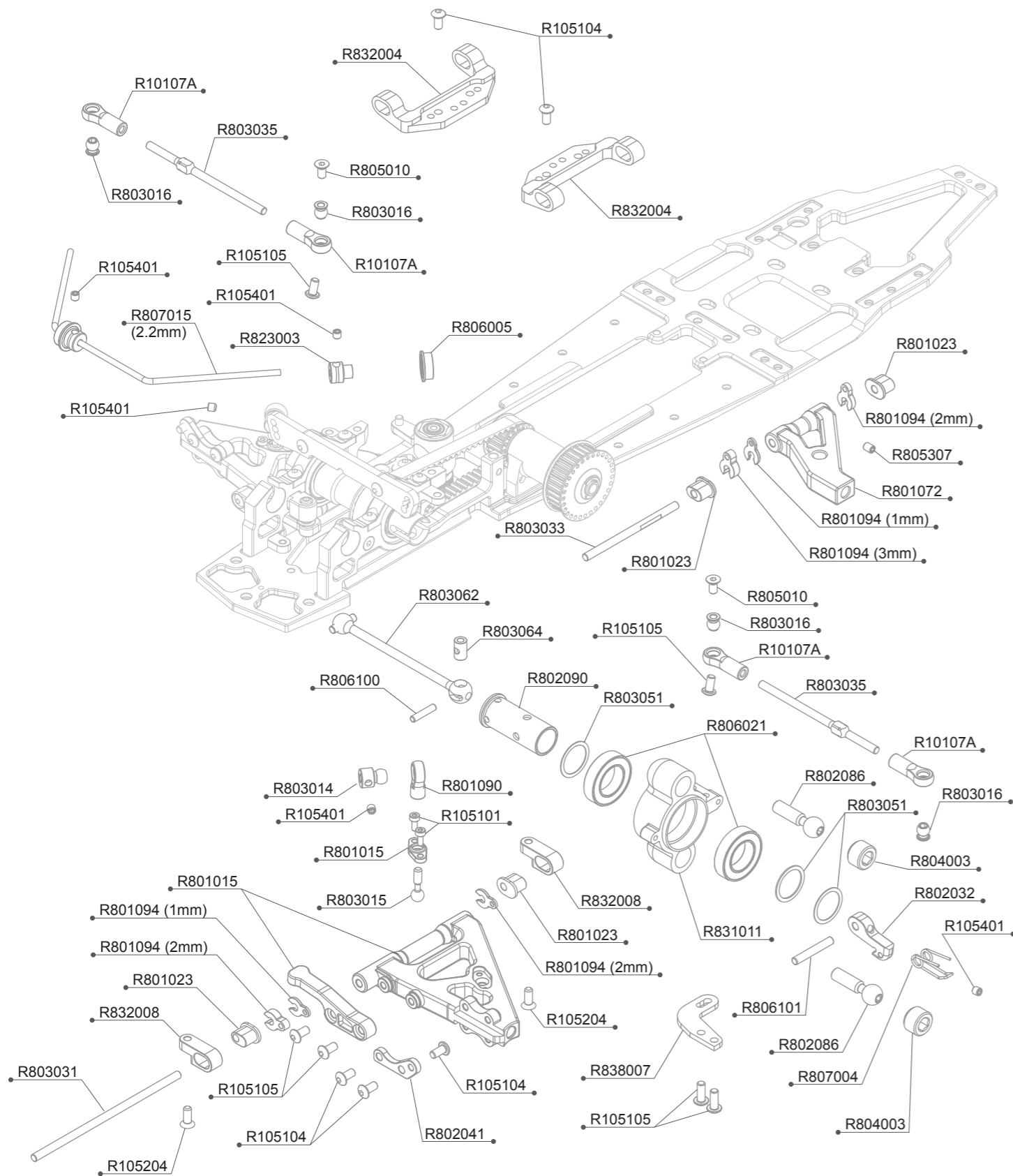

R8.3 BAG 02 PARTS LIST

R10107A	Ball Joint 4.9mm Open (6pcs)	R803033	Front Upper Arm Pin 3x49
R105101	2x5mm Cap Screw (10)	R803035	3mm X 62mm Rod (2)
R105104	3x6 Round Screw (10)	R803051	12.1x15x0.5mm Shims (10)
R105105	3x8 Round Screw (10)	R803062	Front CVD Shaft (2)
R105204	3x8mm Flat Screw (10)	R803064	CVD Insert (2)
R105401	3x3mm Set Screw (10)	R804003	7.9mm Ball End Nut (4)
R801015	Front Low Arm Set	R805010	3x5mm Flat Screw (10)
R801023	Suspension Bracket Insert-Open (8)	R805307	3x6mm Set Screw (10)
R801072	Front Upper Arm (2)	R806005	5x10x4 Flange Ball Bearing (2)
R801090	Ball End 5.8mm (4)	R806021	12x21x5mm Ball Bearing (2)
R801094	C Spacer Set 1mm/2mm/3mm	R806100	Pin 2.5x11.8 (6)
R802032	Front Tire Hook (2)	R806101	Pin 3x19.8 (6)
R802041	Front Shock Mount S (2)	R807004	Tire Hook Spring (4)
R802086	7.9mm Ball End Long-Alu (4)	R807015	Front Anti-Roll Bar 2.2mm
R802090	Front Wheel Axle - Alu (2)	R823003	Anti-Roll Bar Stopper 2.0-2.4 (2)
R803014	Anti Roll Bar Ball Head (2)	R831011	R8.3 Steering Block
R803015	Anti Roll Bar Screw (2)	R832004	R8.3 Front Upper Arm Base
R803016	Ball Head 4.9mm (4)	R832008	R8.3 Front Low Arm Holder (2)
R803031	Front Low Arm Pin 3x77.8	R838007	R8.3 Steering Plate (2)

1:1 SCALE

	R105101 2x5mm Cap Screw (10)		R806100 Ø2.5x11.8 Pin (6)
	R105104 3x6 Round Screw (10)		R806101 Ø3x19.8 Pin (6)
	R105105 3x8 Round Screw (10)		R806005 5x10x4mm Flange Ball Bearing (2)
	R105204 3x8mm Flat Screw (10)		R803051 12.1x15x0.5mm Shims (10)
	R805010 3x5mm Flat Screw (10)		R806021 12x21x5mm Ball Bearing (2)
	R105401 3x3mm Set Screw (10)		
	RR805307 3x6mm Set Screw (10)		

-  **R105204**
3x8mm Flat Screw (10)
-  **R805201**
4x8mm Flat Screw (10)
-  **R805040**
12mm C Clip (6)
-  **R806101**
Ø3x19.8 Pin (6)

1:1 Scale

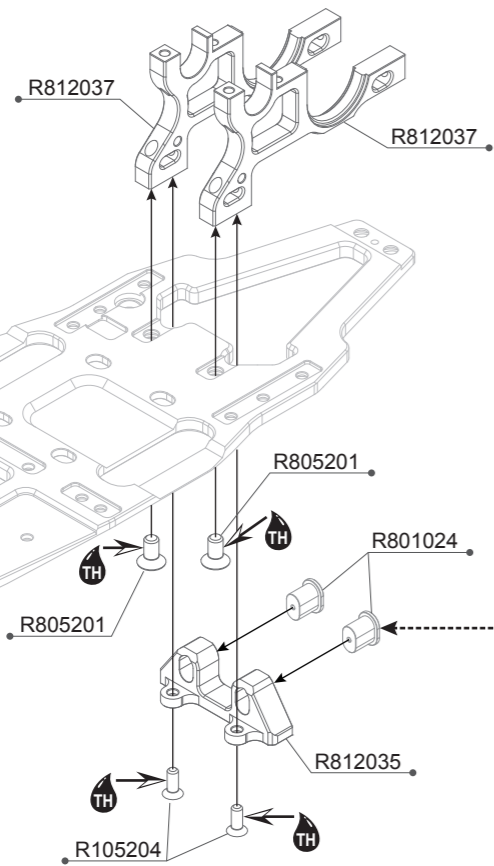
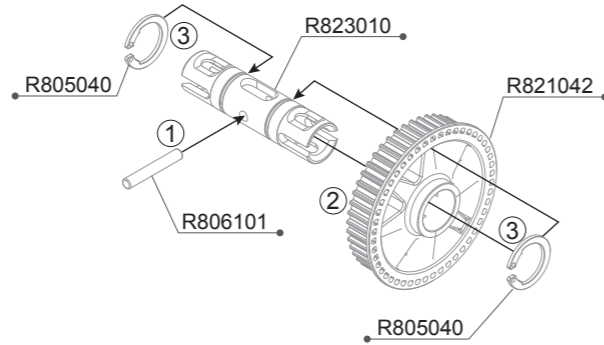

NOTICE



LOW ROLL CENTER / 低的後滾動中心

More initial steering and rear end rolling, and more corner apex traction.
較快的轉向反應與更多的車尾轉動，於彎道頂點時有較多的抓地力。



HIGH ROLL CENTER (DEFAULT SETUP) 高的後滾動中心(預設位置)

Less initial steering and rear end rolling, and less corner apex traction.
較慢的轉向反應與較少的車尾轉動，於彎道頂點時有較少的抓地力。

- R105204 3x8mm Flat Screw (10)
- R801024 Suspension Bracket Insert-Closed (8)
- R805040 12mm C Clip (6)
- R805201 4x8mm Flat Screw (10)
- R806101 Pin 3x19.8 (6)

- R812035 R8.2 Rear Low Arm Bracket RF
- R812037 R8.2 Rear Low Arm Bulkhead
- R823010 R8.2 Rear Solid Axle-Light
- R821042 R8.3 Rear Pulley Set



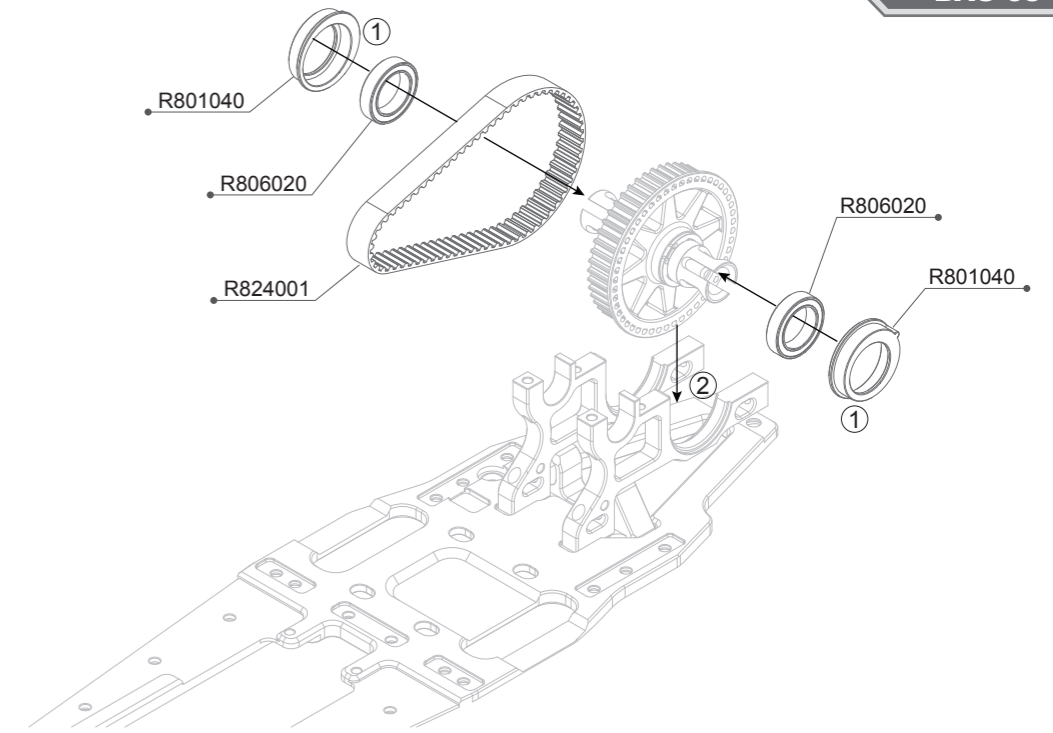

R806020
12x18x4mm Ball Bearing (4)

1:1 Scale



- R801040 Bearing Bushing -Solid Axle (2)
- R806020 12x18x4 Ball Bearing (4)

- R824001 204-8mm Rubber Belt

-  **R105104**
3x6 Round Screw (10)
-  **R105105**
3x8 Round Screw (10)
-  **R805053**
4x10mm Set Screw (10)

1:1 Scale

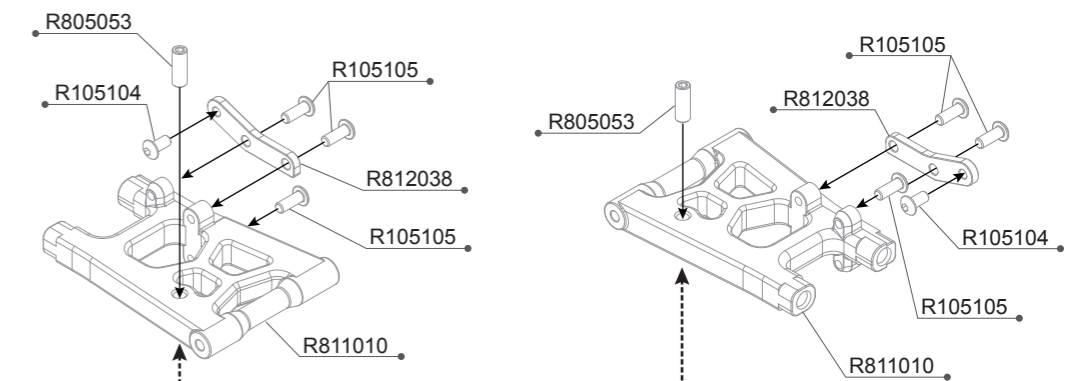

Option Parts (Not Included) / 改裝品(未附於套件內)

- R813005** Downstop Adjust Screw (4)



- R105104 3x6 Round Screw (10)
- R105105 3x8 Round Screw (10)
- R805053 4x10mm Set Screw (10)

- R811010 R8.2 Rear Low Arm-Long
- R812038 R8.2 Rear Low Shock Mount (2)

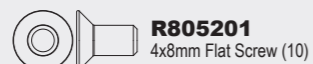

1:1 Scale

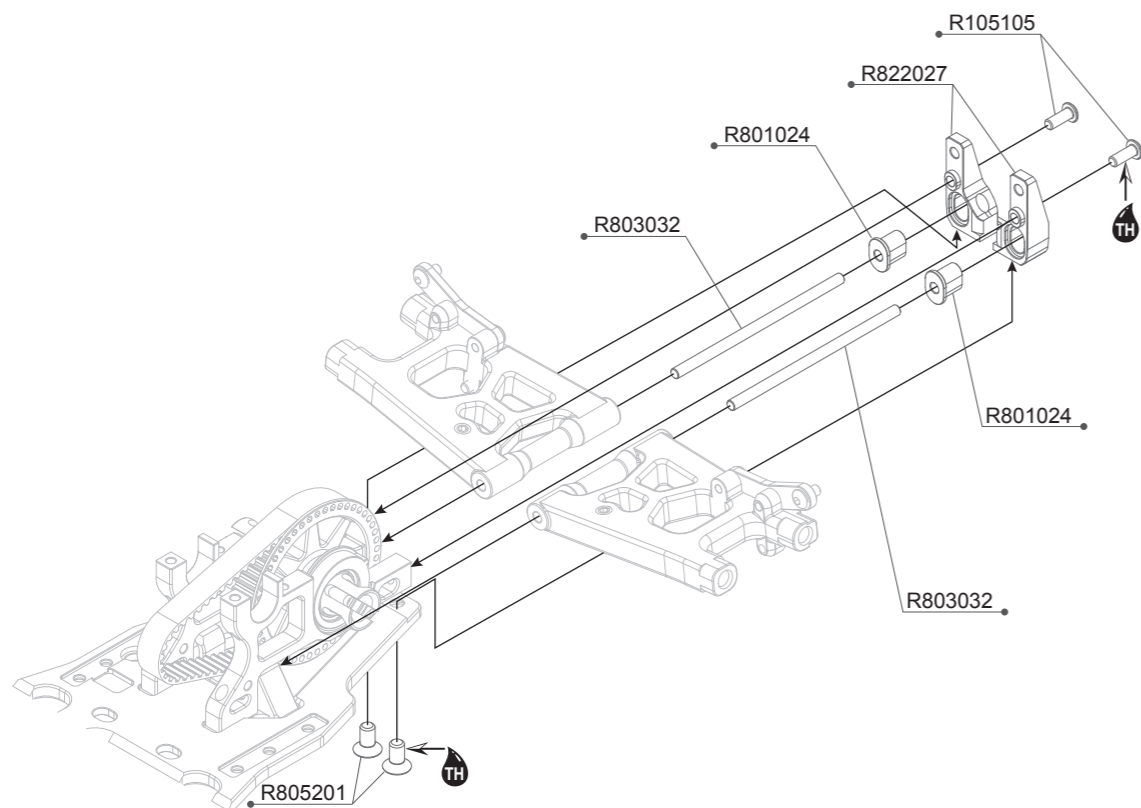

NOTICE

LOW ROLL CENTER / 低的後滾動中心

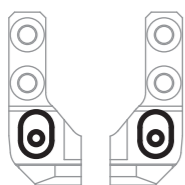

More initial steering and rear end rolling, and more corner apex traction.
較快的初期轉向反應與更多的車尾轉動，於彎道頂點時有較多的抓地力。

HIGH ROLL CENTER (DEFAULT SETUP) / 高的後滾動中心(預設位置)

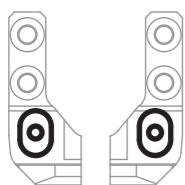

Less initial steering and rear end rolling, and less corner apex traction.
較慢的初期轉向反應與較少的車尾轉動，於彎道頂點時有較少的抓地力。

R105105 3x8 Round Screw (10)
R803032 Rear Low Arm Pin

R805201 4x8mm Flat Screw (10)
R822027 R8.2 LCG Rear Low Arm Bracket-RR Separated

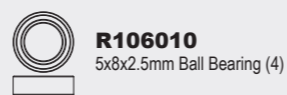

1:1 Scale

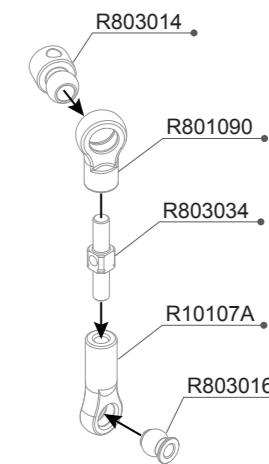
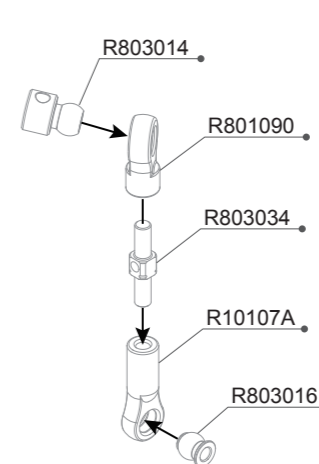
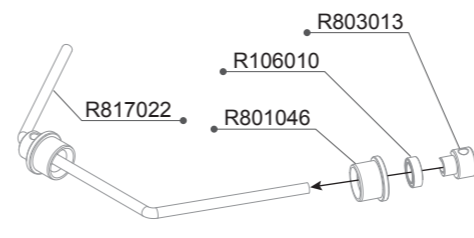

Option Parts (Not Included) / 改裝品(未附於套件內)

R817020 R8.1 Rear Anti-Roll Bar 3.0mm
R817024 R8.1 Rear Anti-Roll Bar 2.6mm

R817026 R8.1 Rear Anti-Roll Bar 2.4mm

R10107A Ball Joint 4.9mm Open (6pcs)
R106010 5x8x2.5mm Ball Bearing (4pcs)
R801046 Anti-Roll Bar Bushing -Front (2)
R801090 Ball End 5.8mm (4)
R803013 Anti Roll Bar Stopper (2)

R803014 Anti Roll Bar Ball Head (2)
R803016 Ball Head 4.9mm (4)
R803034 3mm X 15mm Turnbuckle
R817022 R8.1 Rear Anti-Roll Bar 2.8mm

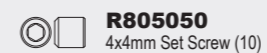
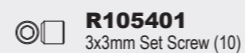

1:1 Scale

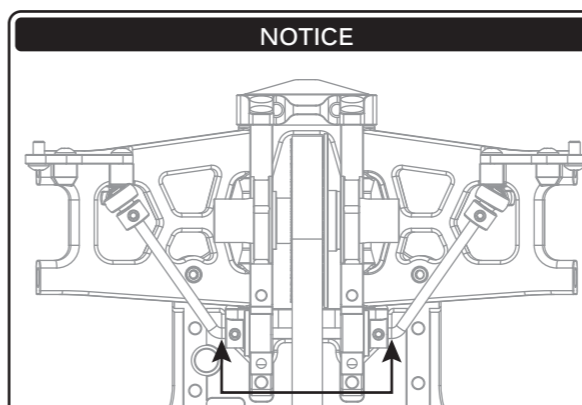

Center the anti roll bar so that the spacing is equal on both sides.
請將後防桿兩邊的間距設定為等寬。

R105401 3x3mm Set Screw (10)

R805050 4x4mm Set Screw (10)

Step 1

Step 2

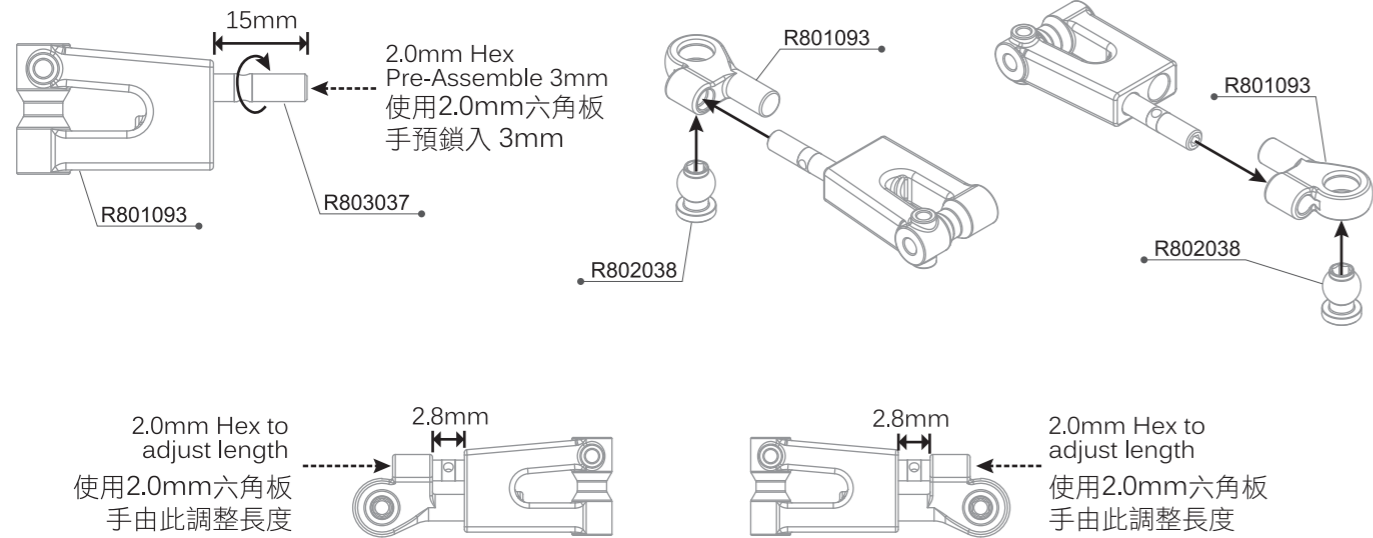

R801093 Rear Upper Arm Set
R802038 Alu Ball Head 6.8mm (2)

R803037 4mm X 17mm Turnbuckle (2)



R105204
3x8mm Flat Screw (10)

1:1 Scale

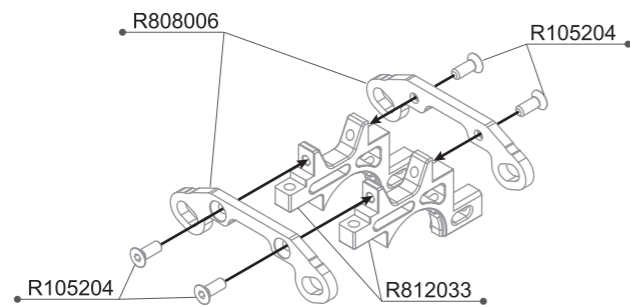

Option Parts (Not Included) / 改裝品 (未附於套件內)

R809020 R8.0 Rear I-Type Upper Arm Set

The I-type arm is useful to fine-tune the car. It gives more options to choose different link angles and makes the rear end respond quicker.

一字型的改裝後上擺臂可提供更多不同位置來做變化，並能使車輛的後輪的反應更加靈活。

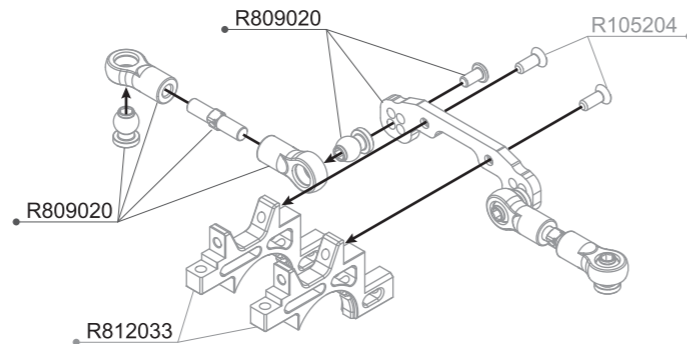

R105204 3x8mm Flat Screw (10)
R808006 Rear Upper Link Plate

R812033 R8.1 Rear Bulkhead Upper

R105402
3x4mm Set Screw (10)

R105204
3x8mm Flat Screw (10)

1:1 Scale

R8.3 REAR UPPER ARM SETUP / R8.3後上擺臂設定表



Shortest rear upper arm / 最短的後上擺臂

Rear end have more response in steering and less traction into corner but more traction in apex and exit corner, Using when under-steering into the corner.

車尾在進彎時有較快的反應與較少的抓地力，但是在彎道頂點與出彎時有較多抓地力，適合使用於進彎轉向不足時。



Medium rear upper arm / 中間長度的後上擺臂

The rear end response and steering are in balance, for most track.

車尾的反應與抓地力在最平衡的狀態，適合大部份的跑道。



Longest rear upper arm / 最長的後上擺臂

Rear end have less response and more traction into corner but less traction in apex and exit corner, Using when over-steering into the corner.

車尾在進彎時有較慢的反應與較多的抓地力，但是在彎道頂點與出彎時有較少抓地力，適合使用在車輛進彎轉向過度時。

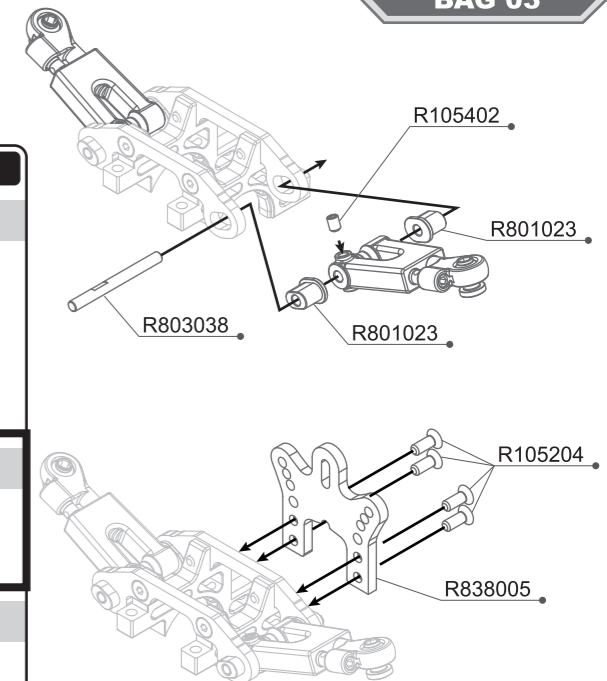

R105204 3x8mm Flat Screw (10)

R105402 3x4mm Set Screw (10)

R801023 Suspension Bracket Insert-Open (8)

R803038 Rear Upper Arm Pin 3x32.5 (2)

R838005 R8.3 Rear Shock Tower

R105105
3x8 Round Screw (10)

R105204
3x8mm Flat Screw (10)

R105206
3x12mm Flat Screw (10)

1:1 Scale

NOTICE

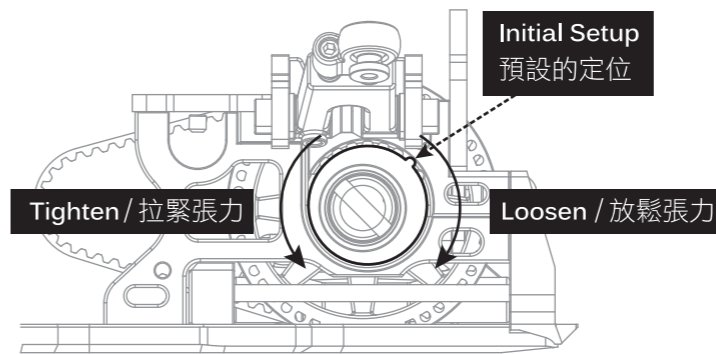

TO ADJUST BELT TENSION / 請依圖示調整皮帶張力

R105105 3x8 Round Screw (10)

R105204 3x8mm Flat Screw (10)

R105206 3x12mm Flat Screw (10)

R818011 R8.1 Rear Anit-Roll Bar Cover

R8.3 BAG 03 PARTS EXPLORE VIEW

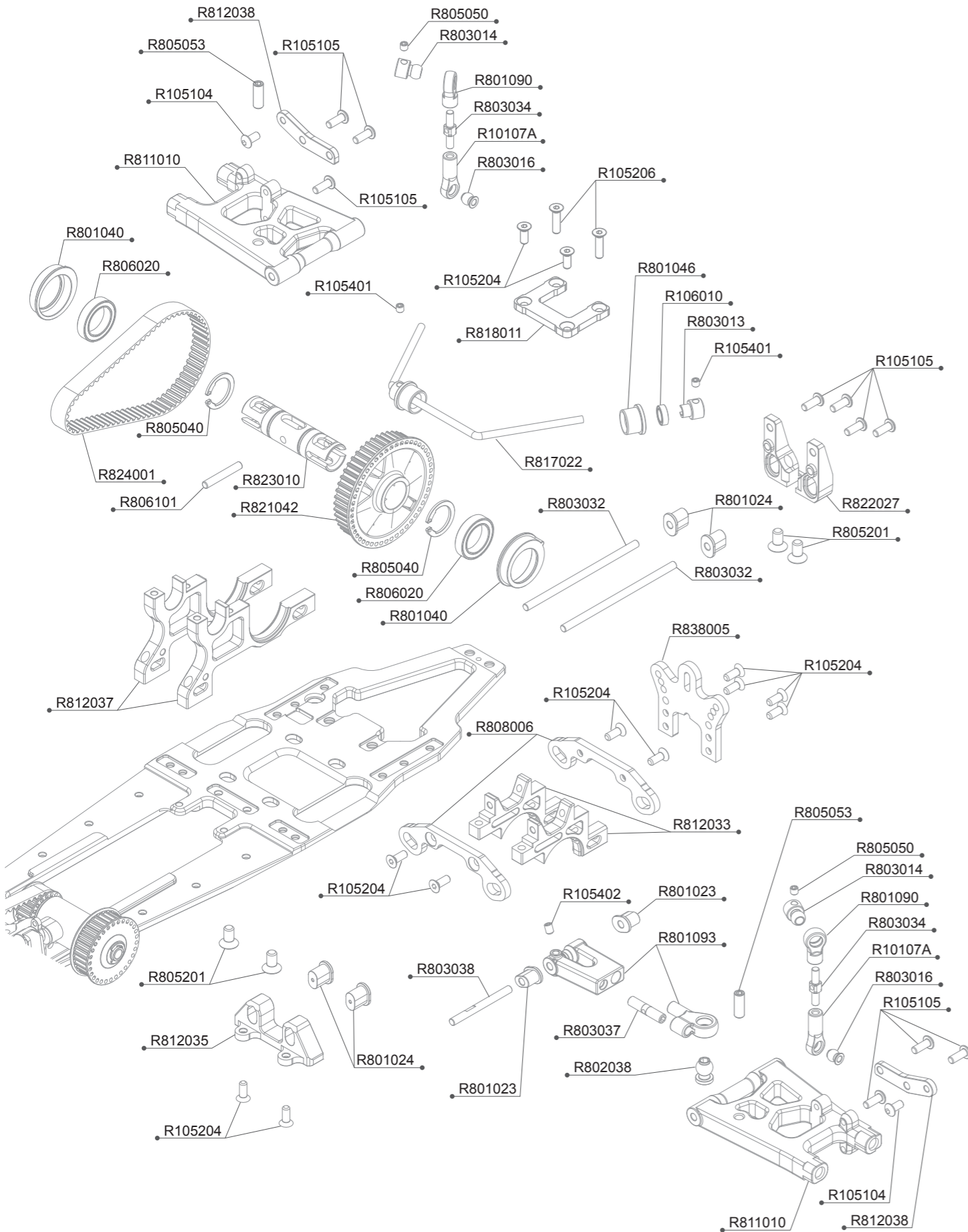

R8.3 BAG 03 PARTS LIST

R10107A	Ball Joint 4.9mm Open (6pcs)	R803038	Rear Upper Arm Pin 3x32.5 (2)
R105104	3x6 Round Screw (10)	R805040	12mm C Clip (6)
R105105	3x8 Round Screw (10)	R805050	4x4mm Set Screw (10)
R105204	3x8mm Flat Screw (10)	R805053	4x10mm Set Screw (10)
R105206	3x12mm Flat Screw (10)	R805201	4x8mm Flat Screw (10)
R105401	3x3mm Set Screw (10)	R806020	12x18x4 Ball Bearing (4)
R105402	3x4mm Set Screw (10)	R806101	Pin 3x19.8 (6)
R106010	5x8x2.5mm Ball Bearing (4pcs)	R808006	Rear Upper Link Plate
R801023	Suspension Bracket Insert-Open (8)	R811010	R8.2 Rear Low Arm-Long
R801024	Suspension Bracket Insert-Closed (8)	R812033	R8.1 Rear Bulkhead Upper
R801040	Bearing Bushing -Solid Axle (2)	R812035	R8.2 Rear Low Arm Bracket RF
R801046	Anti-Roll Bar Bushing -Front (2)	R812037	R8.2 Rear Low Arm Bulkhead
R801090	Ball End 5.8mm (4)	R812038	R8.2 Rear Low Shock Mount (2)
R801093	Rear Upper Arm Set	R817022	R8.1 Rear Anti-Roll Bar 2.8mm
R802038	Alu Ball Head 6.8mm (2)	R818011	R8.1 Rear Anit-Roll Bar Cover
R803013	Anti Roll Bar Stopper (2)	R821042	R8.3 Rear Pulley Set
R803014	Anti Roll Bar Ball Head (2)	R822027	R8.2 LCG Rear Low Arm Bracket-RR Separated
R803016	Ball Head 4.9mm (4)	R823010	R8.2 Rear Solid Axle-Light
R803032	Rear Low Arm Pin	R824001	204-8mm Rubber Belt
R803034	3mm X 15mm Turnbuckle	R838005	R8.3 Rear Shock Tower
R803037	4mm X 17mm Turnbuckle (2)		

1:1 SCALE

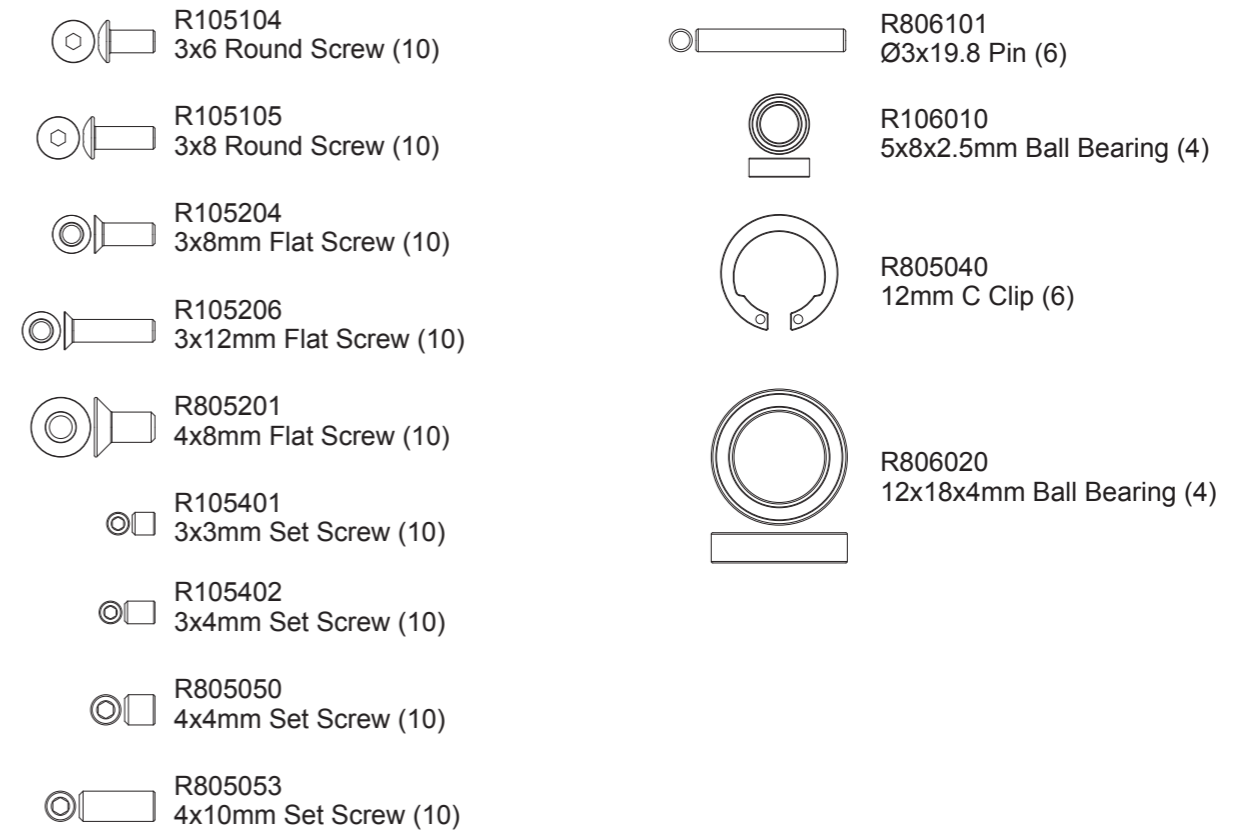

R105401
3x3mm Set Screw (10)

R806100
Ø2.5x11.8 Pin (6)

R806102
Ø3x20.8 Pin (6)

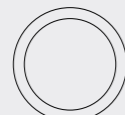

R803050
12.1x15x0.3mm Shims (10)

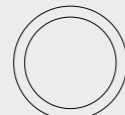

R803051
12.1x15x0.5mm Shims (10)

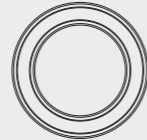

R806020
12x18x4 Ball Bearing (4)

1:1 Scale

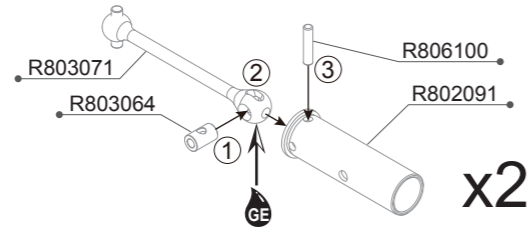

x2

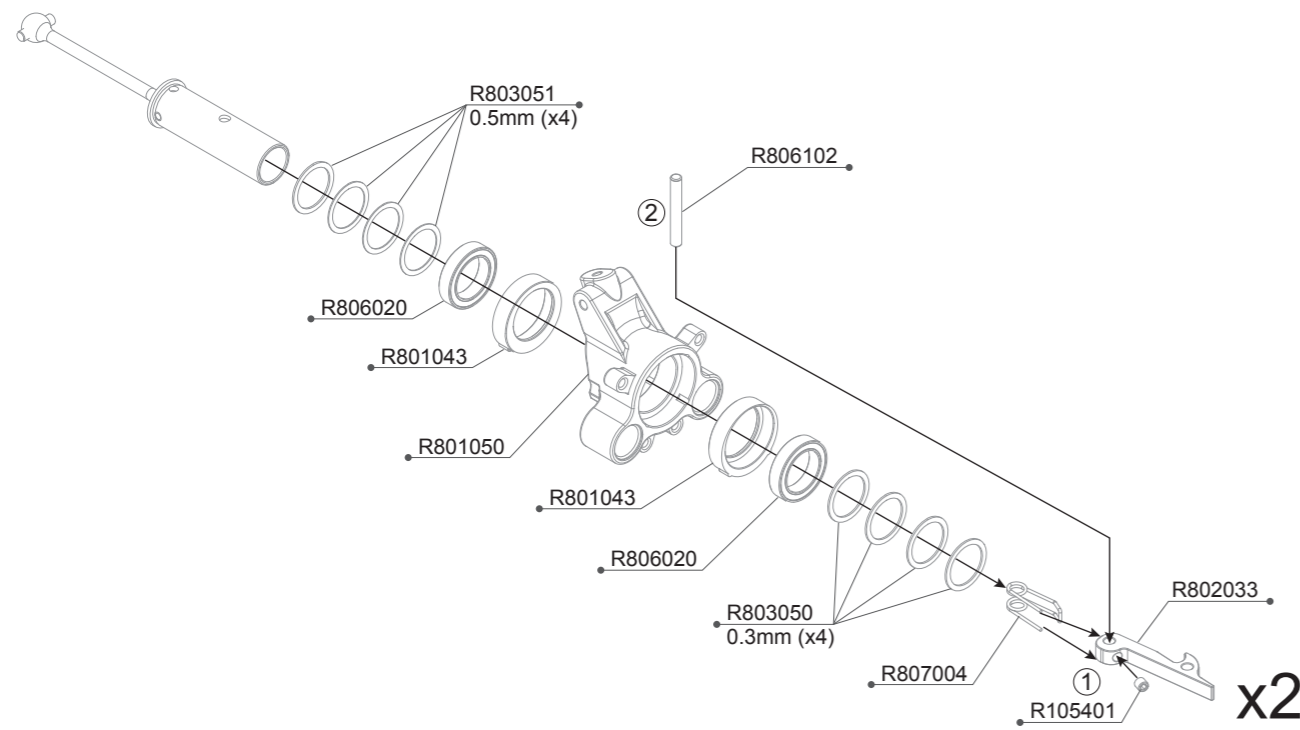

x2

- R105401 3x3mm Set Screw (10)
- R801043 Eccentric Upright Bushing 0/+1 (8)
- R801050 Rear Upright
- R802033 Rear Tire Hook (2)
- R802091 Rear Wheel Axle - Alu (2)
- R803050 12.1x15x0.3mm Shims (10)
- R803051 12.1x15x0.5mm Shims (10)

- R803064 CVD Insert (2)
- R803071 Rear CVD Shaft (2)
- R806020 12x18x4 Ball Bearing (4)
- R806100 Pin 2.5x11.8 (6)
- R806102 Pin 3x20.8 (6)
- R807004 Tire Hook Spring (4)

NOTICE

#R801043 ECCENTRIC HUB INSTRUCTION / 偏心輪座說明

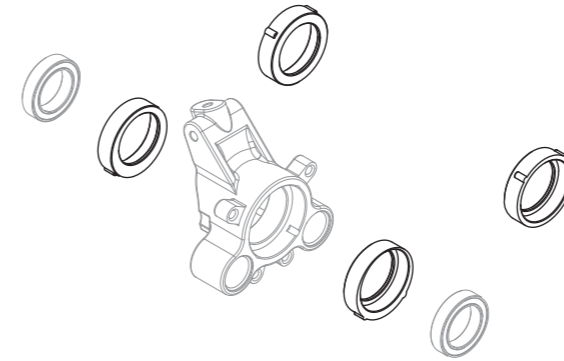

Wheel axle rise 1mm(Default Setup) / 輪軸升高1mm(預設的位置)

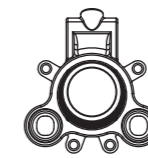

Default setup, it give best overall stability.
預設的位置，車輛整體的穩定性最佳。

Wheel axle in center / 輪軸置中

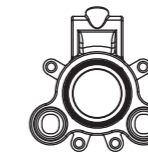

Rear ride height will increase 1mm, and it increase overall steering.
後方車高會升高1mm，會增加車輛整體的反應與轉向性。

R805049
3x16mm Set Screw (10)

1:1 Scale

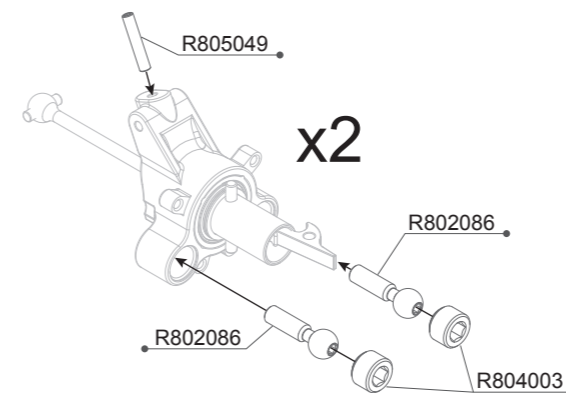

x2

NOTICE

Reserved 6mm / 預留6mm

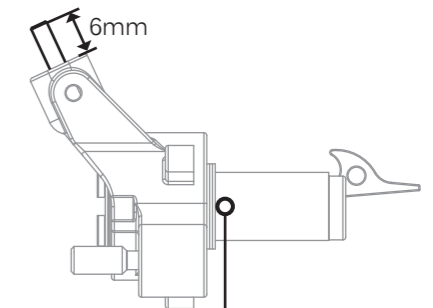

Same length both side / 雙邊需等長

- R802086 7.9mm Ball End Long-Alu (4)
- R804003 7.9mm Ball End Nut (4)

- R805049 3x16mm Set Screw (10)

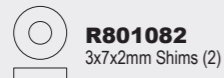
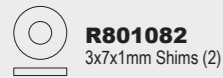

1:1 Scale

NOTICE
Rear low arm width setup
後下擺臂寬度的設定

Rear track width 262mm / 預設後車寬262mm

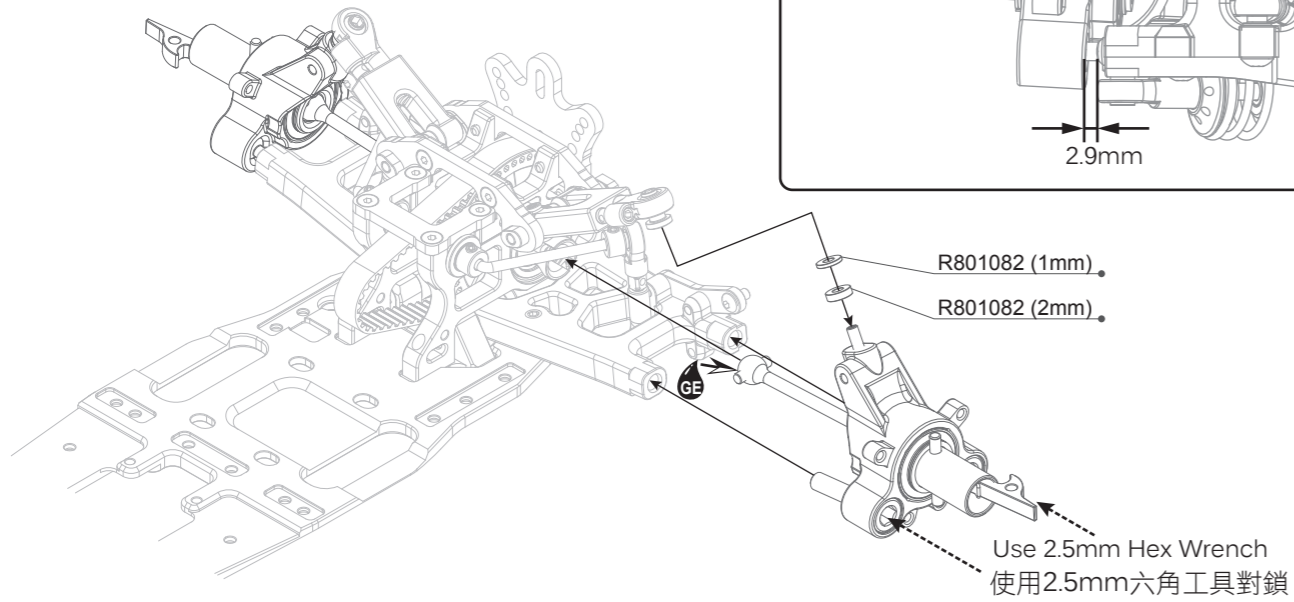
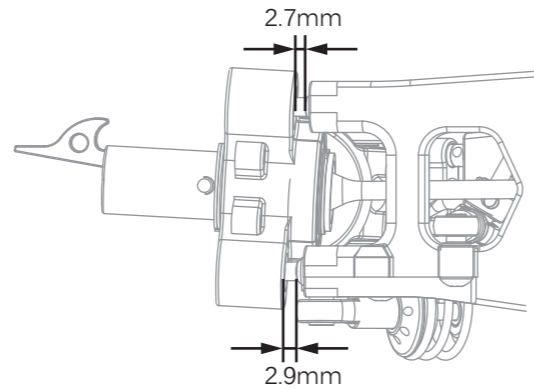

R801082 3x7x1mm & 2mm Shims (2)



1:1 Scale

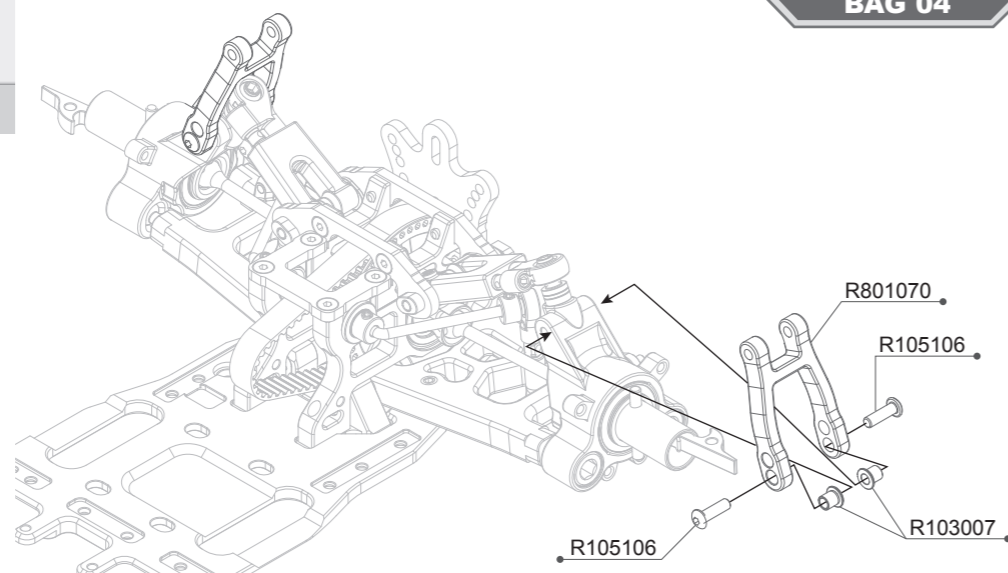

R103007 Steering Block Bushing(4pcs)
R105106 3x10 Round Screw (10)

R801070 Rear Body Mount Arm (2)

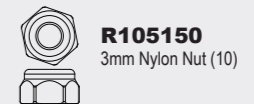
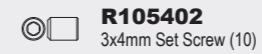
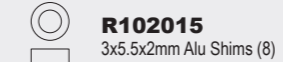
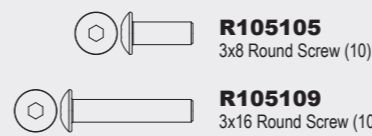

1:1 Scale

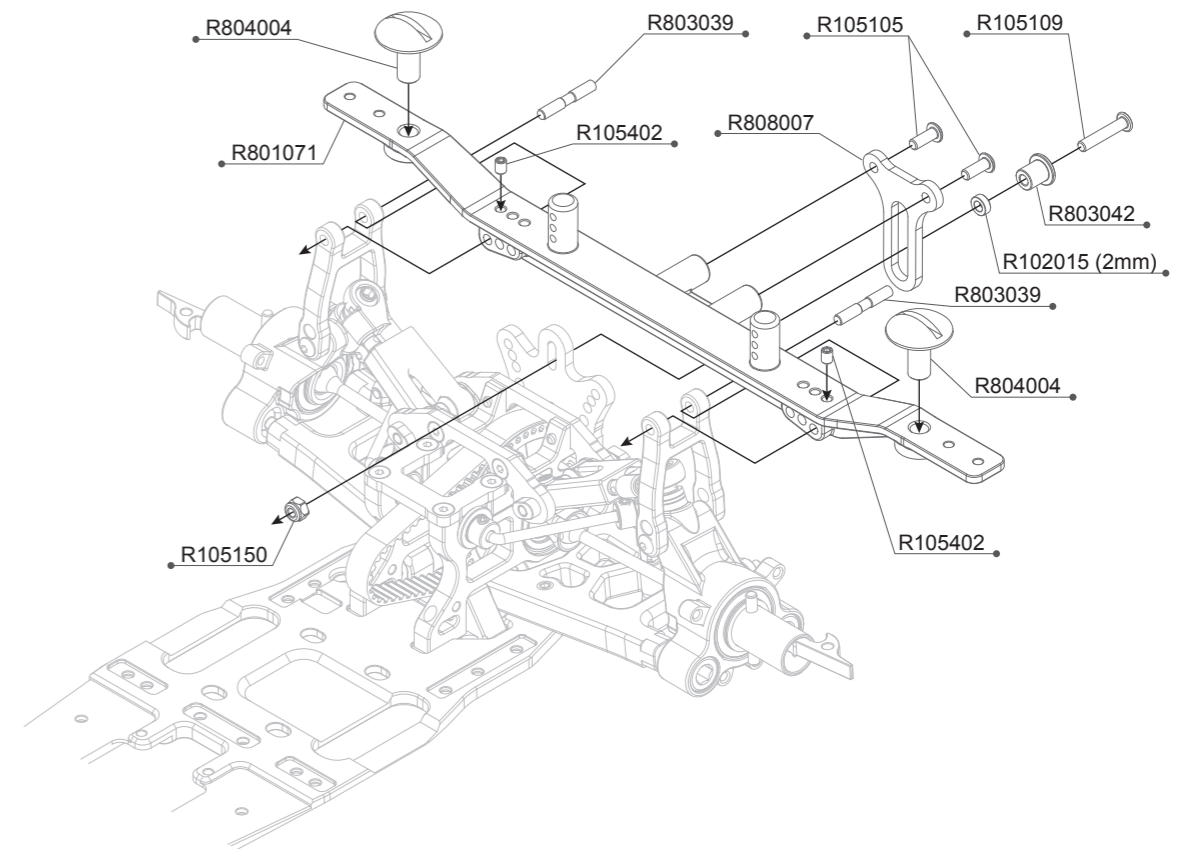

Option Parts (Not Included) / 改裝品 (未附於套件內)

R819001 R8.1 Rear Body Mount Ball Bearing Tower Set

Function: Less friction for rear body tower
可減少後車殼固定架的磨擦使活動更順暢

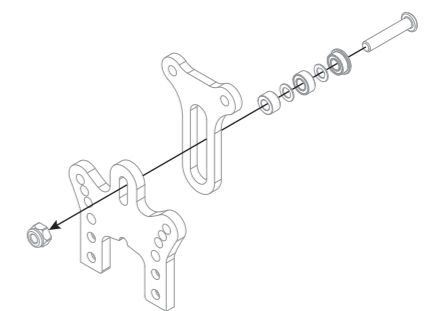

R102015 3x5.5x2mm Alu Shims(8pcs)
R105105 3x8 Round Screw (10)
R105109 3x16 Round Screw (10)
R105150 3mm Nylon Nut (10)
R105402 3x4mm Set Screw (10)

R801071 Rear Body Mount
R803039 Rear Body Mount Pin 3x19.5 (2)
R803042 Rear Body Mount Nut
R804004 Body Mount Screw(4)
R808007 Rear Body Mount Plate

R8.3 BAG 04 PARTS EXPLORE VIEW

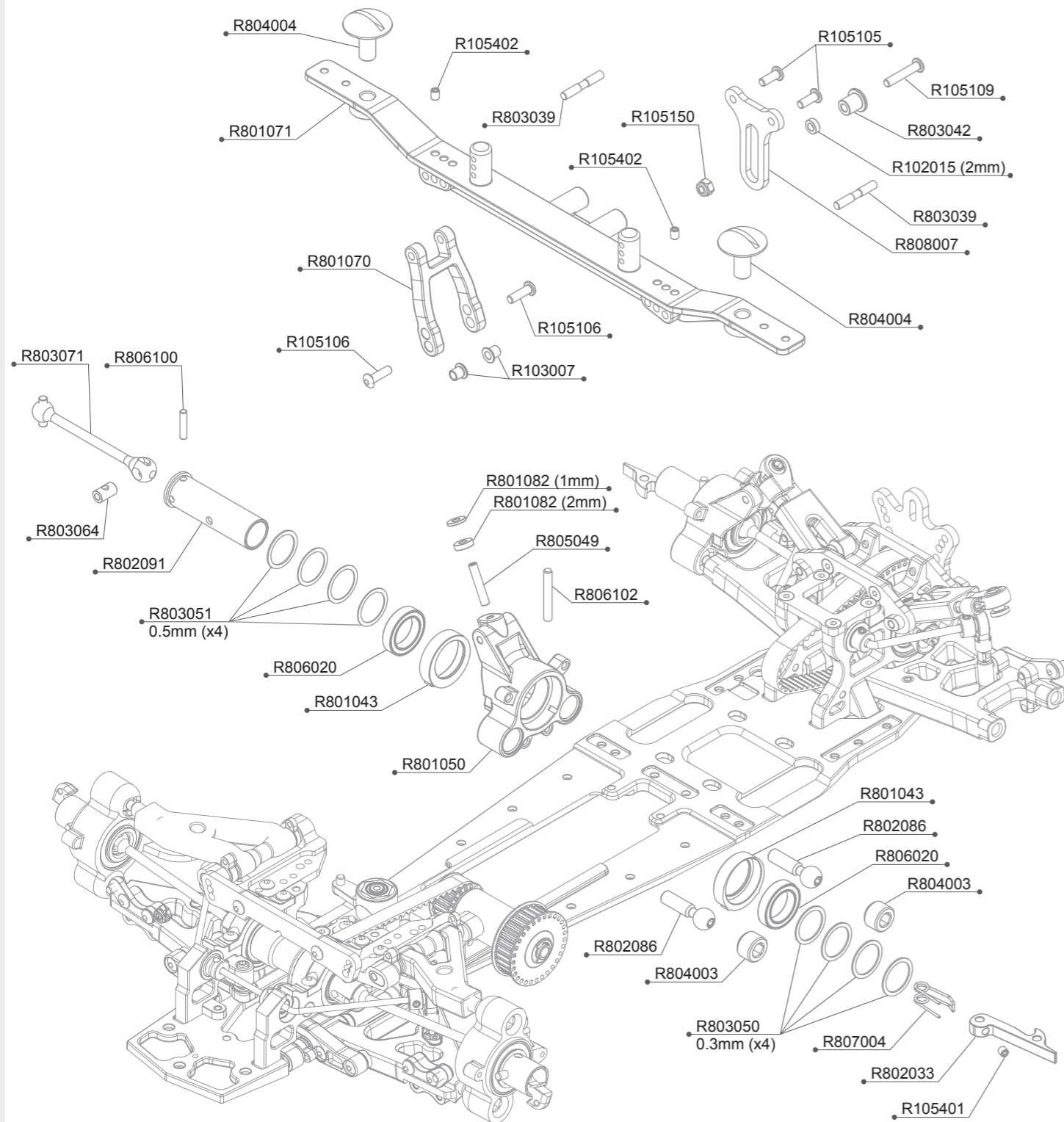



R8.3 BAG 04 PARTS LIST

R102015	3x5.5x2mm Alu Shims(8pcs)	R802091	Rear Wheel Axle - Alu (2)
R103007	Steering Block Bushing(4pcs)	R803039	Rear Body Mount Pin 3x19.5 (2)
R105105	3x8 Round Screw (10)	R803042	Rear Body Mount Nut
R105106	3x10 Round Screw (10)	R803050	12.1x15x0.3mm Shims (10)
R105109	3x16 Round Screw (10)	R803051	12.1x15x0.5mm Shims (10)
R105150	3mm Nylon Nut (10)	R803064	CVD Insert (2)
R105401	3x3mm Set Screw (10)	R803071	Rear CVD Shaft (2)
R105402	3x4mm Set Screw (10)	R804003	7.9mm Ball End Nut (4)
R801043	Eccentric Upright Bushing 0/+1 (8)	R804004	Body Mount Screw(4)
R801050	Rear Upright	R805049	3x16mm Set Screw (10)
R801070	Rear Body Mount Arm (2)	R806020	12x18x4 Ball Bearing (4)
R801071	Rear Body Mount	R806100	Pin 2.5x11.8 (6)
R801082	3x7x1mm & 2mm Shims (2)	R806102	Pin 3x20.8 (6)
R802033	Rear Tire Hook (2)	R807004	Tire Hook Spring (4)
R802086	7.9mm Ball End Long-Alu (4)	R808007	Rear Body Mount Plate

1:1 SCALE

	R102015 3x5.5x2mm Alu Shims (8)		R805049 3x16mm Set Screw (10)
	R801082 3x7x1mm & 2mm Shims (2)		R806100 Ø2.5x11.8 Pin (6)
	R801082 3x7x1mm & 2mm Shims (2)		R806102 Ø3x20.8 Pin (6)
	R105401 3x3mm Set Screw (10)		R105150 3mm Nylon Nut (10)
	R105402 3x4mm Set Screw (10)		R806020 12x18x4mm Ball Bearing (4)
	R105105 3x8 Round Screw (10)		R803050 12.1x15x0.3mm Shims (10)
	R105106 3x10 Round Screw (10)		R803051 12.1x15x0.5mm Shims (10)
	R105109 3x16 Round Screw (10)		

-  **R105203**
3x6mm Flat Screw (10)
-  **R105204**
3x8mm Flat Screw (10)
-  **R105205**
3x10mm Flat Screw (10)
-  **R106010**
5x8x2.5mm Ball Bearing (4)
-  **R806012**
8x16x5mm Ball Bearing (2)

1:1 Scale

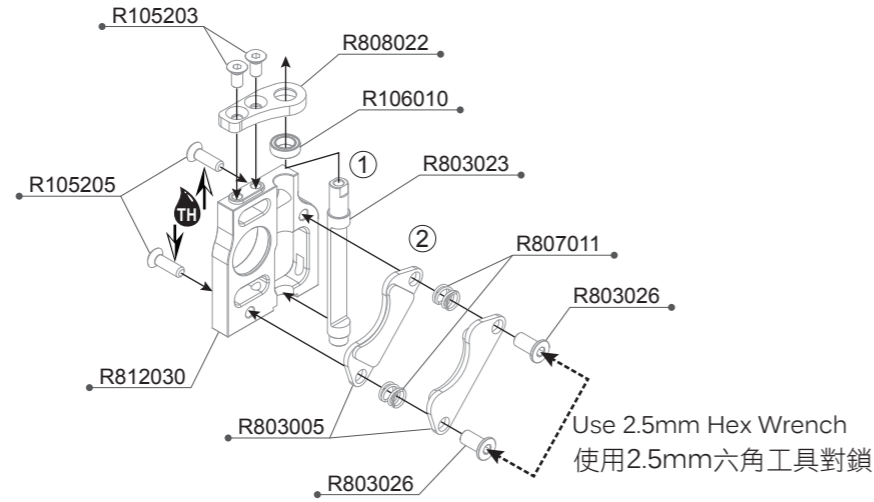

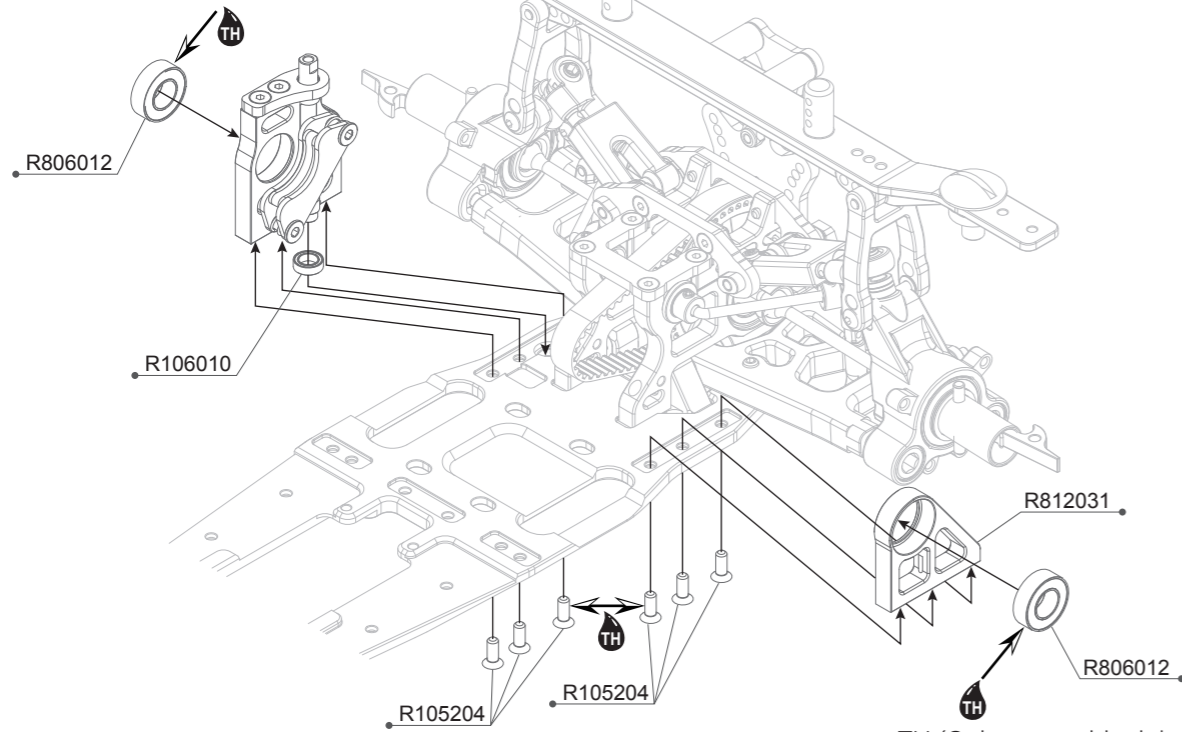

TH (Only on outside right surface)
防鬆膠請塗抹在外環的表面



TH (Only on outside right surface)
防鬆膠請塗抹在外環的表面

- | | | | |
|---------|-------------------------------|---------|------------------------------|
| R105203 | 3x6mm Flat Screw (10) | R803026 | Brake Pad Nut Long (2) |
| R105204 | 3x8mm Flat Screw (10) | R806012 | 8x16x5mm Ball Bearing (2) |
| R105205 | 3x10mm Flat Screw (10) | R807011 | Brake Spring (2) |
| R106010 | 5x8x2.5mm Ball Bearing (4pcs) | R808022 | Brake Deck |
| R803005 | Brake Pad | R812030 | R8.1 2-Speed Shaft Bracket R |
| R803023 | Brake Cam-High | R812031 | R8.1 2-Speed Shaft Bracket L |

-  **R805010**
3x5mm Flat Screw (10)
-  **R806010**
8x12x3.5mm Ball Bearing (2)

1:1 Scale



Spare Parts

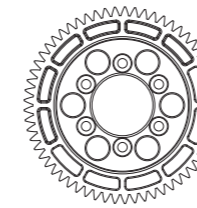

R804051
1st Spur 61T

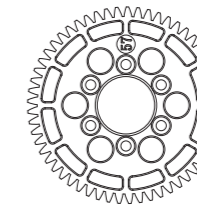

R804054
2nd Spur 57T

Option Parts (Not Included) / 改裝品 (未附於套件內)

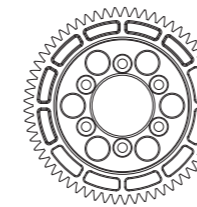

R804052
1st Spur 62T

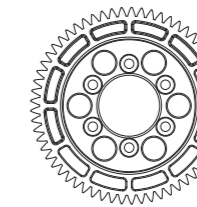

R804055
2nd Spur 58T

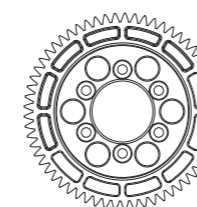

R804050
1st Spur 60T

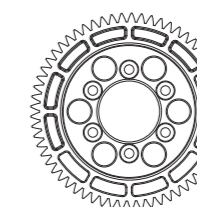

R804053
2nd Spur 56T

- | | | | |
|---------|----------------------|---------|-----------------------------|
| R802053 | 1-Speed Spur Adaptor | R805010 | 3x5mm Flat Screw (10) |
| R804051 | 1st Spur 61T | R806010 | 8x12x3.5mm Ball Bearing (2) |
| R804054 | 2nd Spur 57T | R822029 | R8.3 2 Speed Bell |

R805055
4x3mm Set Screw (4)

R806120
Ø5x4.9 Pin (6)

1:1 Scale

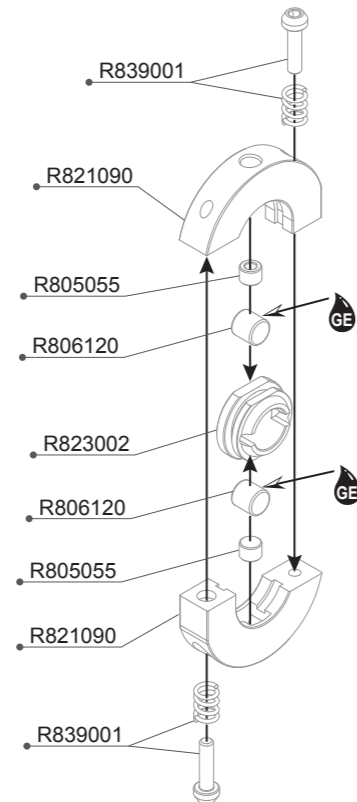

NOTICE



Using 2.0mm Hex wrench go through 2 speed shoes and pull up the screw with reverse directly to tight the screw into 2 speed shoes.
使用2.0mm工具穿過二段甩片並將螺絲以逆時鐘方向拉回並鎖入二段甩片內。

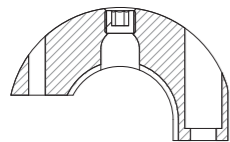

Make sure the screw surface just match with 2 speed shoes.
將螺絲鎖到與二段甩片如圖示切齊。

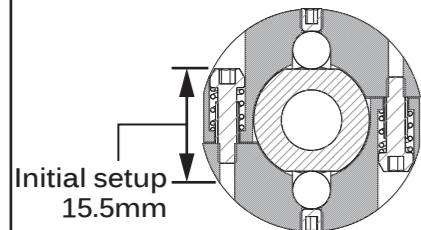

Please set the 2 speed screw distance like instruction in 15.5mm, shorter the distance will make 2speed shift slower, longer the distance will make 2 speed shift early.
請將二段變速的調整螺絲初始距離依圖示設在15.5mm，此距離越短變速的時間越晚，此距離越長變速的時間越早。

R805055 4x3mm Set Screw (4)
R806120 Pin 5x4.9 (6)
R823002 R8.2 2-Speed Adaptor

R821090 R8.3 2-Speed Shoes (2)
R839001 R8.3 2-Speed Spring Set

R805046
E-Clip 7mm (6)

R806100
Ø2.5x11.8 Pin (6)

1:1 Scale

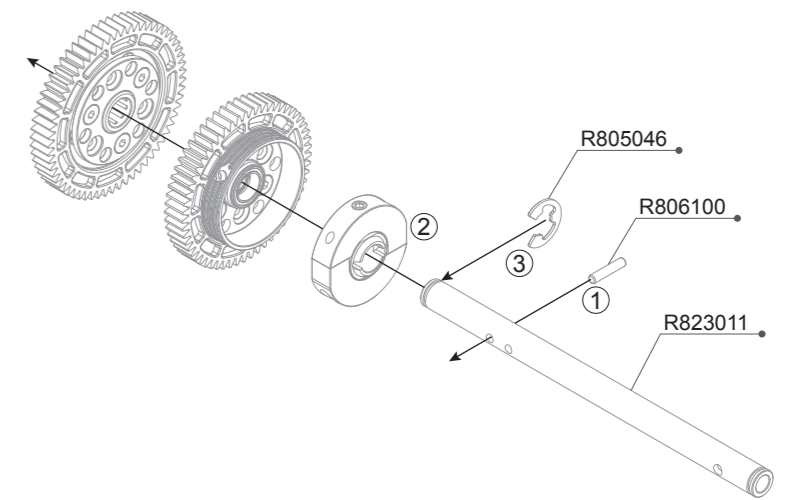

R805046 E-Clip 7mm (6)
R806100 Pin 2.5x11.8 (6)

R823011 R8.2 2 Speed Main Shaft

R806111
Ø3x11.8 Pin (6)

R805050
4x4mm Set Screw (10)

R805046
E-Clip 7mm (6)

1:1 Scale

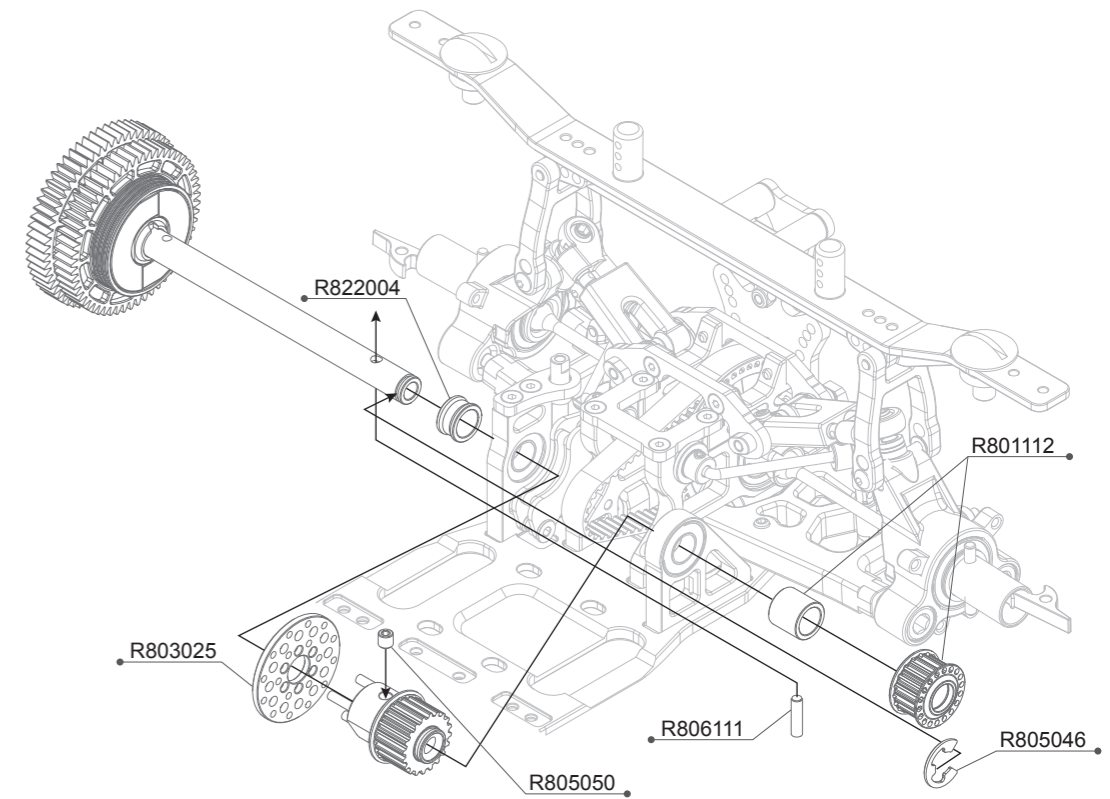
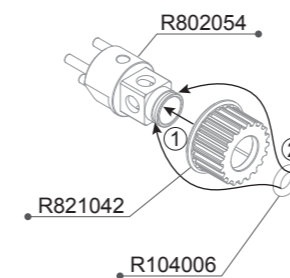

R104006 O'ring 5x2(4pcs)
R801112 Pulley Set -Middle
R802054 Brake Adaptor
R803025 Brake Disk Drilled
R805046 E-Clip 7mm (6)

R805050 4x4mm Set Screw (10)
R806111 Pin 3x11.8 (6)
R822004 2-Speed Shaft Shim-Alu
R821042 R8.3 Rear Pulley Set

R105204
3x8mm Flat Screw (10)

R805050
4x4mm Set Screw (10)

R105105
3x8 Round Screw (10)

R806005
5x10x4mm
Flange Ball Bearing (2)

R105109
3x16 Round Screw (10)

1:1 Scale

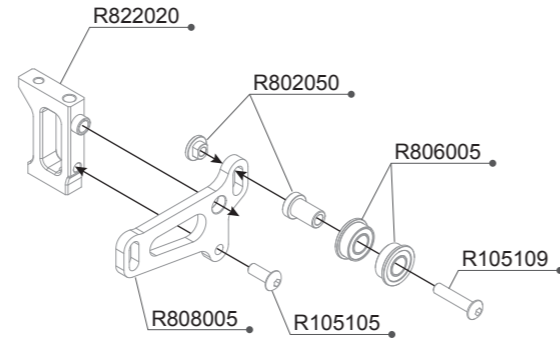

Move here to adjust middle belt tension.
請移動中皮帶壓輪的位置來調整中度帶的張力。

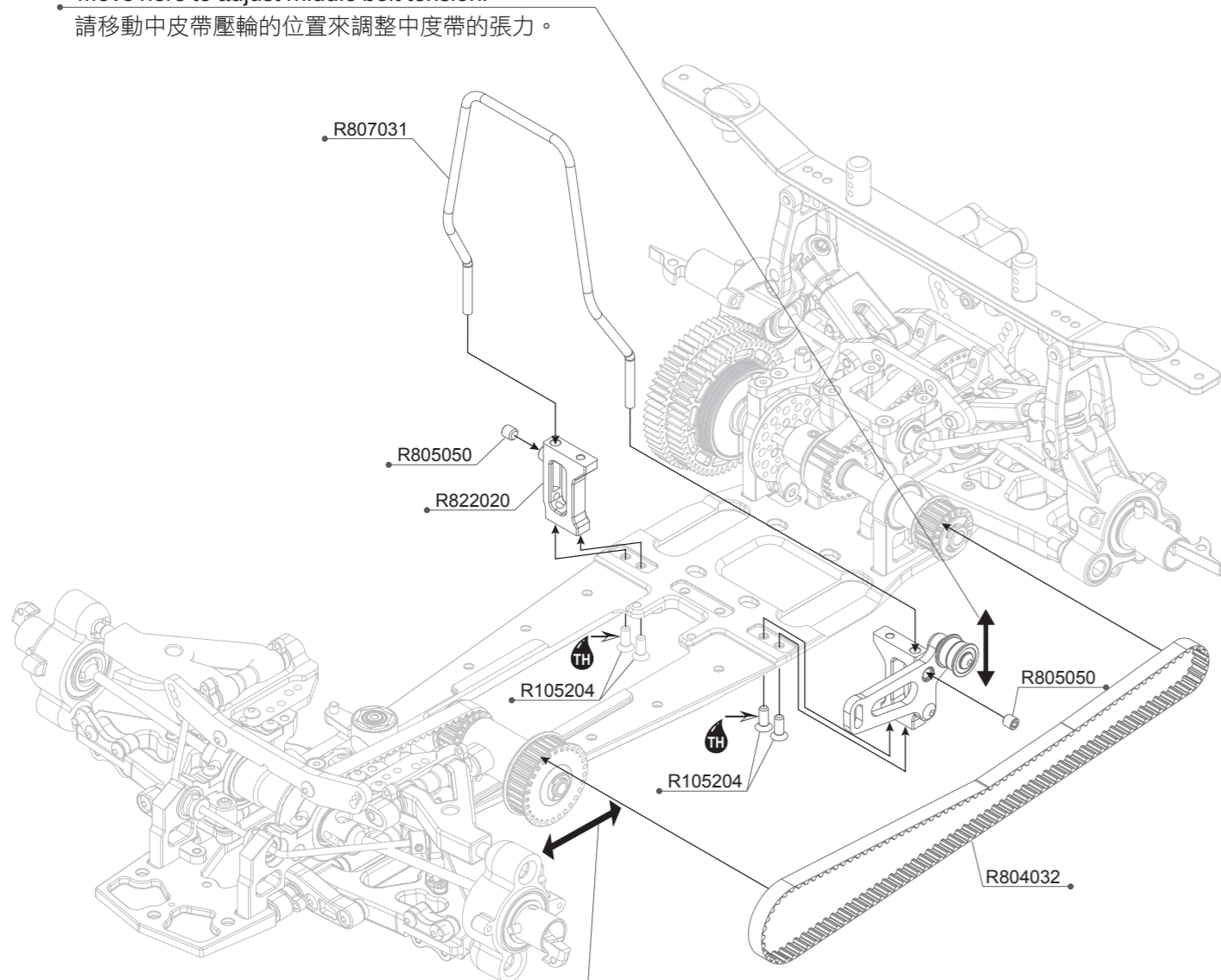

Move here to adjust front and middle belt tension.
可移動中軸座的位置來調整前/中皮帶的張力。

R105105 3x8 Round Screw (10)
R105109 3x16 Round Screw (10)
R105204 3x8mm Flat Screw (10)
R802050 Belt Tensioner Shaft
R804032 Middle Belt 435

R805050 4x4mm Set Screw (10)
R806005 5x10x4 Flange Ball Bearing (2)
R807031 Rollover Bar
R808005 Belt Tensioner Plate
R822020 R8.2 LCG Center Bulkhead

R805103
4x10 Round Screw (10)

R805203
4x12mm Flat Screw (10)

R805302
4mm Nylon Nut (10)

1:1 Scale

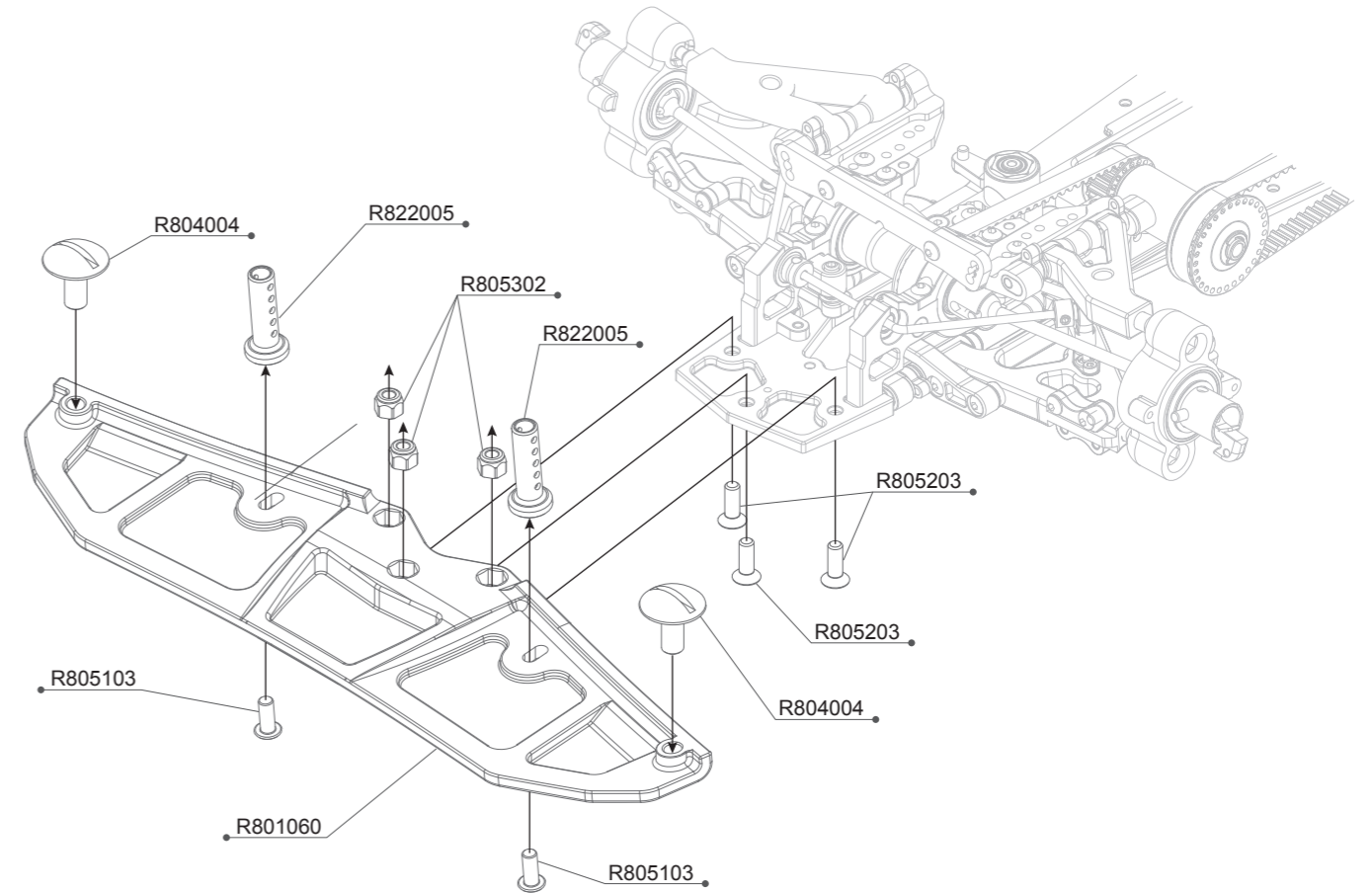

NOTICE

The front body tower is able to move 4mm for fine tune the body-shell position, recommend to start from position 0.
前車殼支柱共有4mm的距離可用來微調車殼的位置，建議由圖示中的0做為起啟位置。

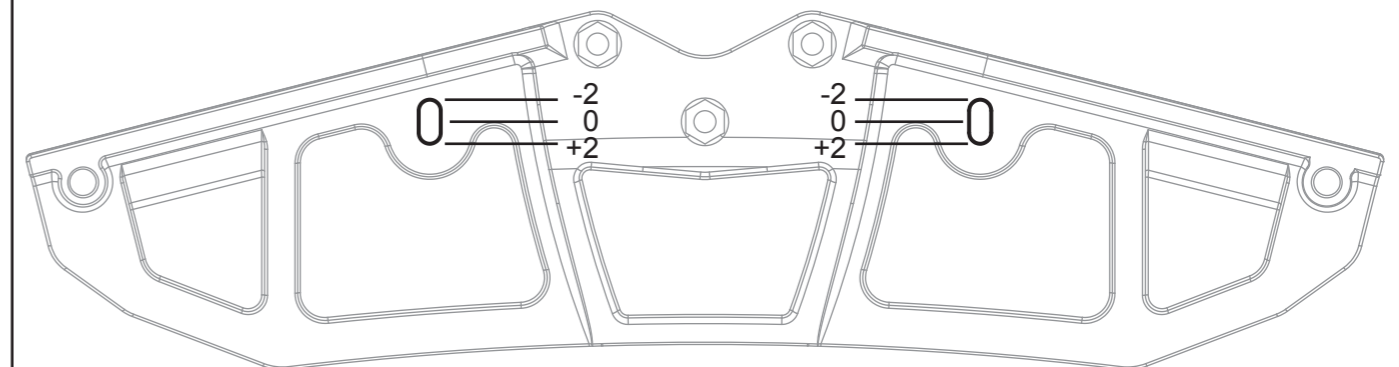

R801060 R 8.0 Bumper Set
R804040 2 Speed Shoes (2)
R805103 4x10 Round Screw (10)

R805203 4x12mm Flat Screw (10)
R805302 4mm Nylon Nut (10)
R822005 1/8 On-Road Car Front Body Tower (Alu) (2)

R8.3 BAG 05 PARTS EXPLORE VIEW

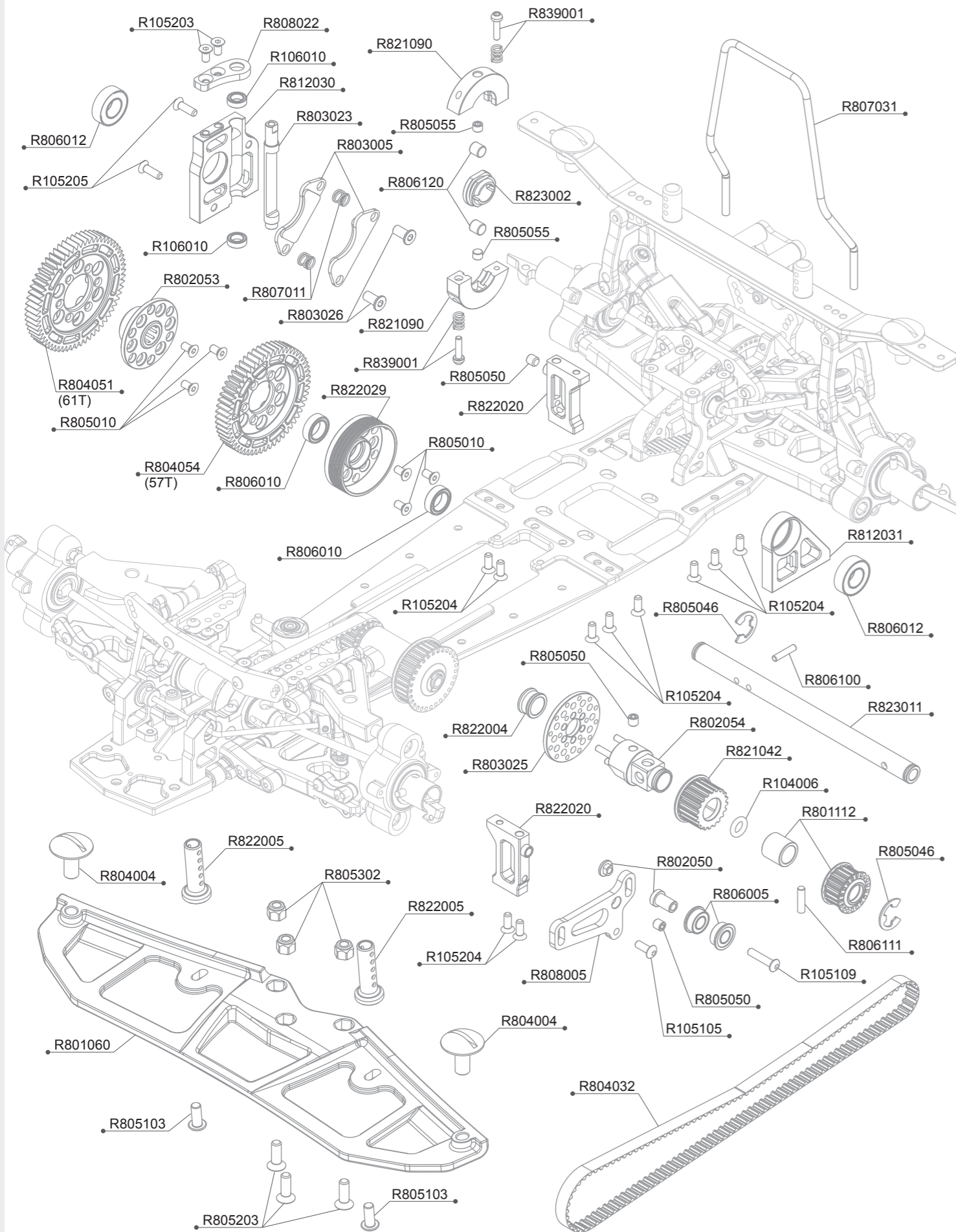

R8.3 BAG 05 PARTS LIST

R104006	O'ring 5x2(4pcs)	R805103	4x10 Round Screw (10)
R105105	3x8 Round Screw (10)	R805203	4x12mm Flat Screw (10)
R105109	3x16 Round Screw (10)	R805302	4mm Nylon Nut (10)
R105203	3x6mm Flat Screw (10)	R806005	5x10x4 Flange Ball Bearing (2)
R105204	3x8mm Flat Screw (10)	R806010	8x12x3.5 Ball Bearing (2)
R105205	3x10mm Flat Screw (10)	R806012	8x16x5mm Ball Bearing (2)
R106010	5x8x2.5mm Ball Bearing (4pcs)	R806100	Pin 2.5x11.8 (6)
R801060	R 8.0 Bumper Set	R806111	Pin 3x11.8 (6)
R801112	Pulley Set -Middle	R806120	Pin 5x4.9 (6)
R802050	Belt Tensioner Shaft	R807011	Brake Spring (2)
R802053	1-Speed Spur Adaptor	R807031	Rollover Bar
R802054	Brake Adaptor	R808005	Belt Tensioner Plate
R803005	Brake Pad	R808022	Brake Deck
R803023	Brake Cam-High	R812030	R8.1 2-Speed Shaft Bracket R
R803025	Brake Disk Drilled	R812031	R8.1 2-Speed Shaft Bracket L
R803026	Brake Pad Nut Long (2)	R821042	R8.3 Rear Pulley Set
R804004	Body Mount Screw(4)	R821090	R8.3 2-Speed Shoes (2)
R804032	Middle Belt 435	R822004	2-Speed Shaft Shim-Alu
R804051	1st Spur 61T	R822005	1/8 On-Road Car Front Body Tower (Alu) (2)
R804054	2nd Spur 57T	R822020	R8.2 LCG Center Bulkhead
R805010	3x5mm Flat Screw (10)	R822029	R8.3 2 Speed Bell
R805046	E-Clip 7mm (6)	R823002	R8.2 2-Speed Adaptor
R805050	4x4mm Set Screw (10)	R823011	R8.2 2 Speed Main Shaft
R805055	4x3mm Set Screw (4)	R839001	R8.3 2-Speed Spring Set

1:1 SCALE

	R105105 3x8 Round Screw (10)		R106010 5x8x2.5mm Ball Bearing (4)
	R105109 3x16 Round Screw (10)		R806005 5x10x4mm Flange Ball Bearing (2)
	R805103 4x10 Round Screw (10)		R806010 8x12x3.5mm Ball Bearing (2)
	R105203 3x6mm Flat Screw (10)		R806012 8x16x5 Ball Bearing (2)
	R105204 3x8mm Flat Screw (10)		R805302 4mm Nylon Nut (10)
	R105205 3x10mm Flat Screw (10)		R805046 E-Clip 7mm (6)
	R805010 3x5mm Flat Screw (10)		R806100 Ø2.5x11.8 Pin (6)
	R805203 4x12mm Flat Screw (10)		R806111 Ø3x11.8 Pin (6)
	R805050 4x4mm Set Screw (10)		
	R805055 4x3mm Set Screw (4)		

FRONT / 前避震器

REAR / 後避震器

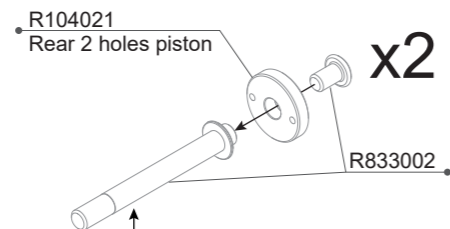
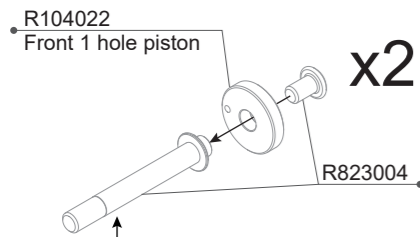

Option Parts (Not Included) / 改裝品 (未附於套件內)

R839002 R8.3 Shock Shaft-Titanium Coating (4)

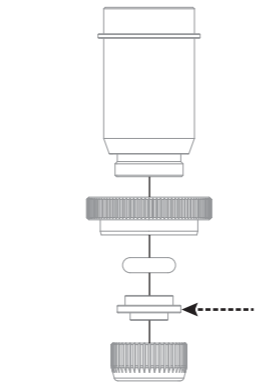
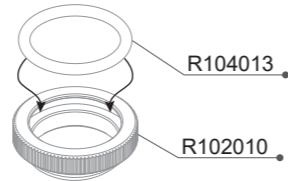
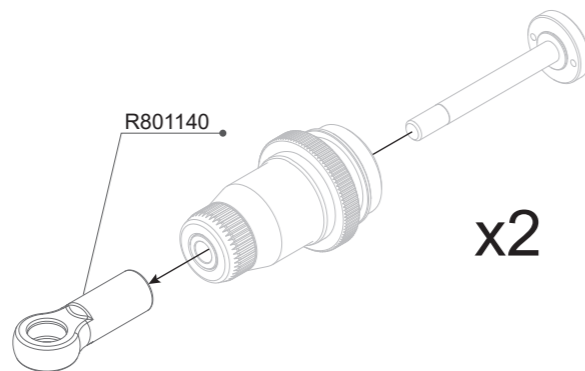
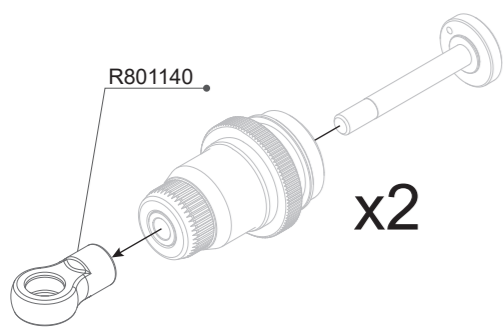
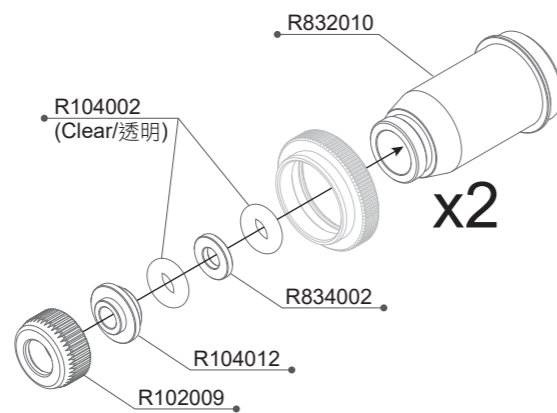
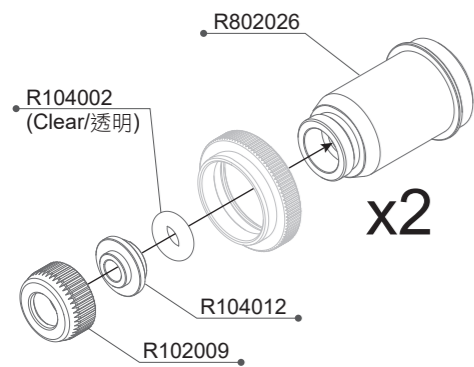

NOTICE



NOTICE

Fill #500 Cst Oil both front & rear
請使用#500CST避震油於前後避震器

#500

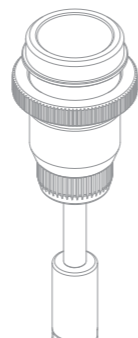

- R102009 Shock Low Cap Alu(2pcs)
- R102010 Shock ADJ Nut Alu (2pcs)
- R104002 O'ring 3x2(4pcs)
- R104012 Shock Shaft Shim(4pcs)
- R104013 O'ring 13x1 (2pcs)
- R104021 Shock Piston 1mm X 2 Hole (4pcs)
- R104022 Shock Piston 1mm X 1 Hole (4pcs)

- R801140 Shock Ball Joint Set V2
- R802026 Shock Body-V2016 (2)
- R823004 Shock Shaft-Screw Type (4)
- R832010 R8.3 Rear Shock Body (2)
- R833002 R8.3 Rear Shock Shaft (2)
- R834002 Shock Shims (2)

FRONT / 前避震器

REAR / 後避震器

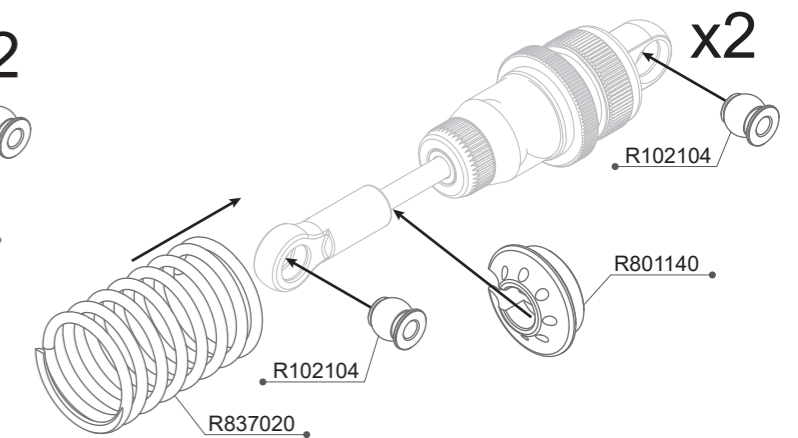
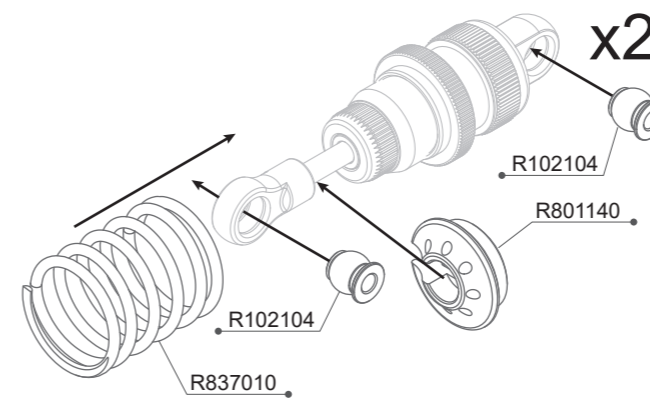
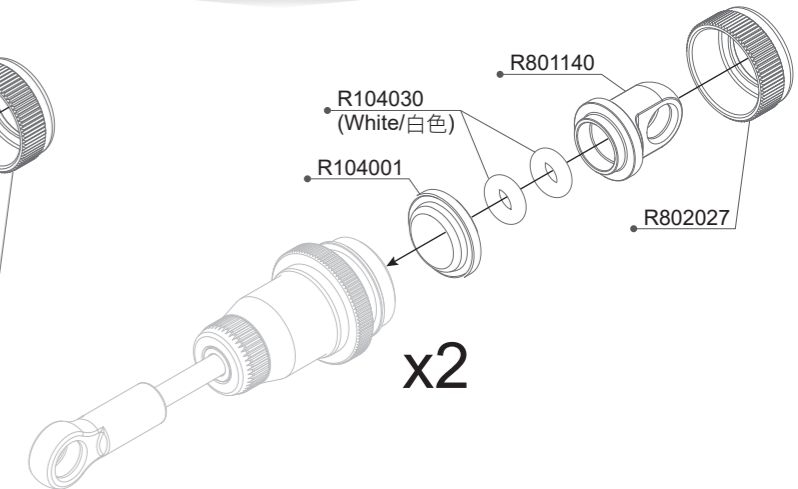
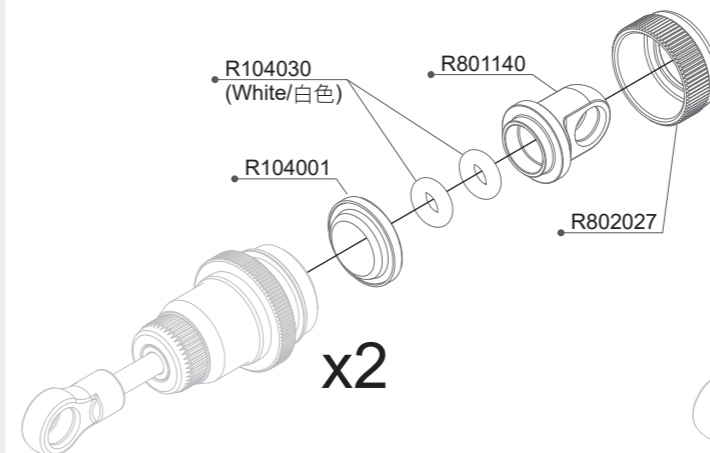

NOTICE

FRONT (Short) Set to 65.5mm
前避震器總長請設定成65.5mm

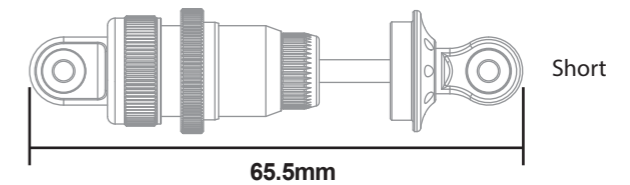

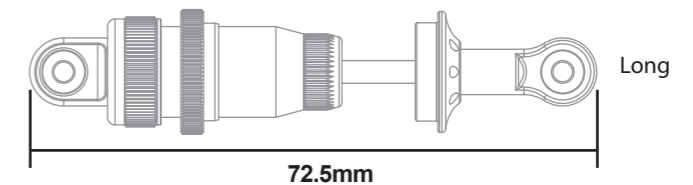

REAR (Long) Set to 72.5mm
後避震器總長請設定成72.5mm



Build shocks to the following lengths / 請依圖示來設定避震器長度

- R102104 5.8mm Ball end Short type Alu (4pcs)
- R104001 Shock Chamber(4pcs)
- R104030 O'ring 3x2 (Soft)(4pcs)
- R801140 Shock Ball Joint Set V2

- R802027 Shock Cap-V2016 (2)
- R837010 R8.3 Front Shock Spring-White
- R837020 R8.3 Rear Shock Spring-White

-  **R105104**
3x6 Round Screw (10)
-  **R105105**
3x8 Round Screw (10)
-  **R105107**
3x12 Round Screw (10)

1:1 Scale

Standard Servo/標準伺服機
(Not Included/未附於套件內)

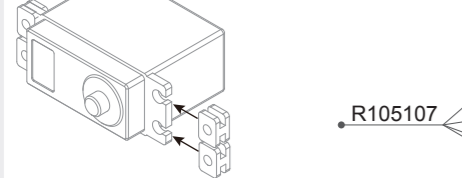

Low Profile Servo/短版伺服機
(Not Included/未附於套件內)

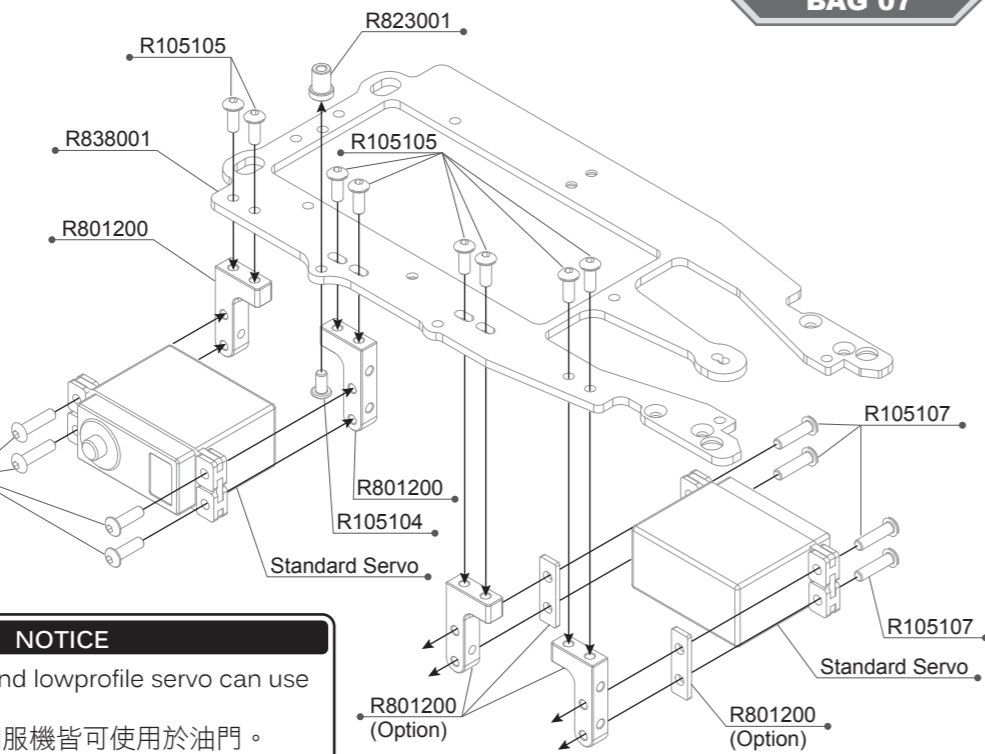
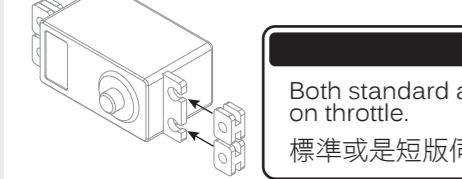



NOTICE

Both standard and lowprofile servo can use on throttle.
標準或是短版伺服機皆可使用於油門。

- R105104 3x6 Round Screw (10)
- R105105 3x8 Round Screw (10)
- R105107 3x12 Round Screw (10)

- R801200 Servo Mount Set
- R823001 Throttle Lever Base
- R838001 R8.3 Upper Deck

-  **R105104**
3x6 Round Screw (10)
-  **R805299**
2.5x6mm Cap Screw (10)

1:1 Scale

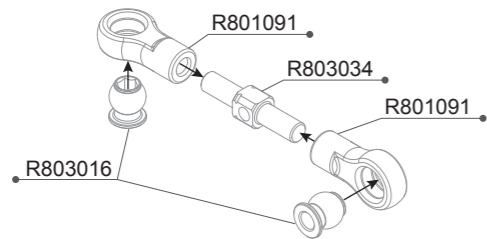

NOTICE

5.0mm

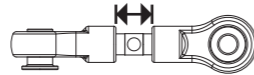

Initial length setup / 預設的長度

Option Parts (Not Included)
/ 改裝品 (未附於套件內)

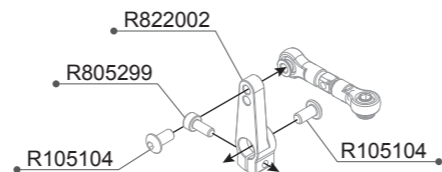

R822002 R8.2 Steering Servo Horn 25T-Alu

The R822002 with different angle at fully turn, give more support in high speed corner.
使用R822002 可在全舵角時與高速彎時提供更大的支撐力。



- R101060 Servo Horn Dual steering arm
- R105104 3x6 Round Screw (10)
- R801091 Ball End 4.9mm Short (2)

- R803016 Ball Head 4.9mm (4)
- R803034 3mm X 15mm Turnbuckle

-  **R105105**
3x8 Round Screw (10)
-  **R805305**
2x8mm Flat Screw (10)
-  **R105150**
3mm Nylon Nut (10)

1:1 Scale

NOTICE

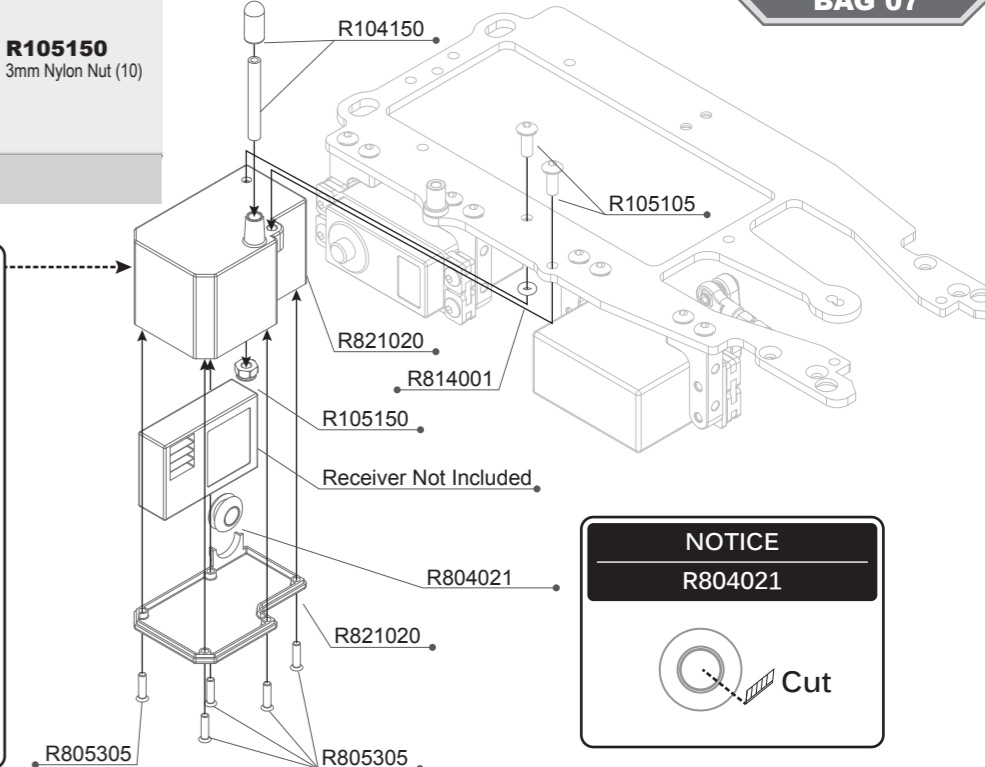
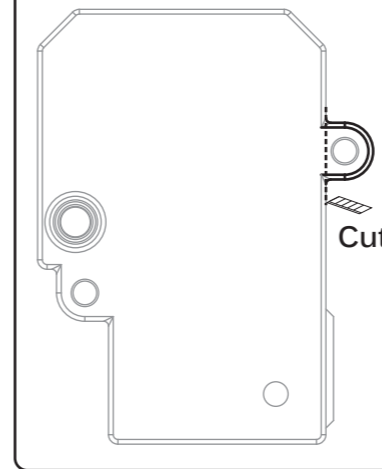

NOTICE

R804021

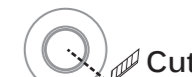

- R104150 Antenna (1set)
- R105105 3x8 Round Screw (10)
- R105150 3mm Nylon Nut (10)
- R804021 Rubber Grommet (2)

- R805305 2x8mm Flat Screw (10)
- R814001 2x1.5 O'ring (6)
- R821020 R8.2 Radio Box

-  **R105104**
3x6 Round Screw (10)

1:1 Scale

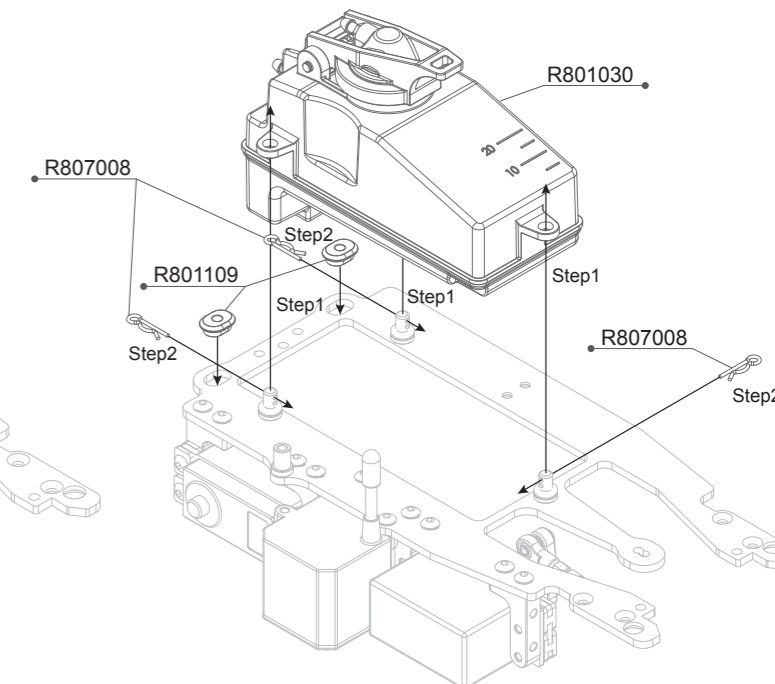
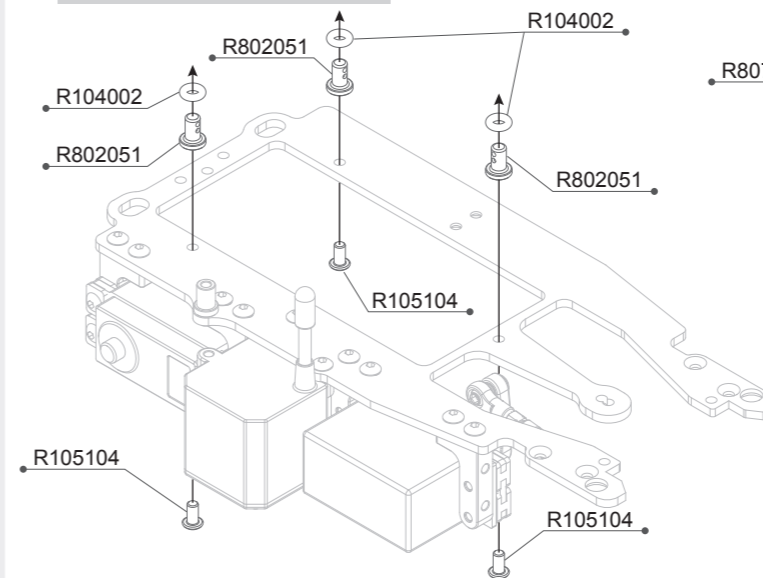

- R104002 O'ring 3x2(4pcs)
- R105104 3x6 Round Screw (10)
- R801030 Fuel Tank with insert

- R801109 Upper Deck Insert (2)
- R802051 Fuel Tank Mount (3)
- R807008 3mm R Clip (10)

-  **R105105**
3x8 Round Screw (10)
-  **R105203**
3x6mm Flat Screw (10)

1:1 Scale

NOTICE

Using R838003 on Upper Deck
使用R838003二樓板固定板

With R838003 the upper-deck will become harder in front end, it will increase initial steering response but decrease mid and exit corner steering.

使用R838003會使二樓板的前半段變的比較硬，並增加車輛轉向的初期反應，但是會減少車輛中末期的轉向力

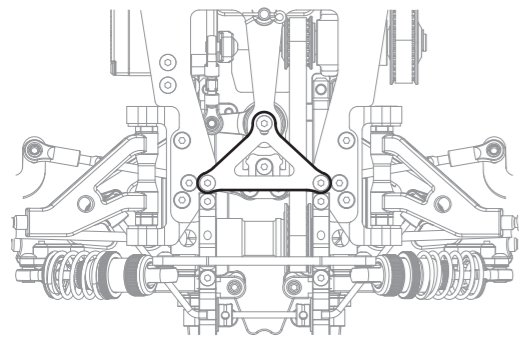

Original Upperdeck(Default Setup)
使用原廠二樓板

The standard upper-deck works most different track and traction, recommend default setup.

原廠的二樓板可適合在大多數不同的場地及抓地力，為原廠建議的設定。

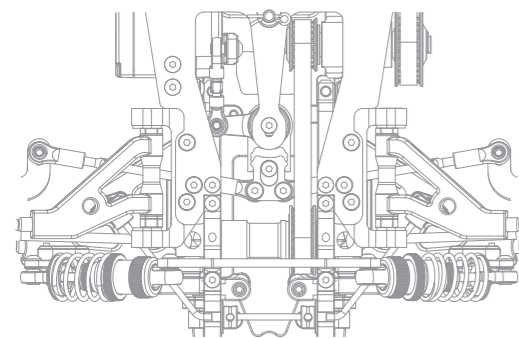

R105105 3x8 Round Screw (10)

R105203 3x6mm Flat Screw (10)

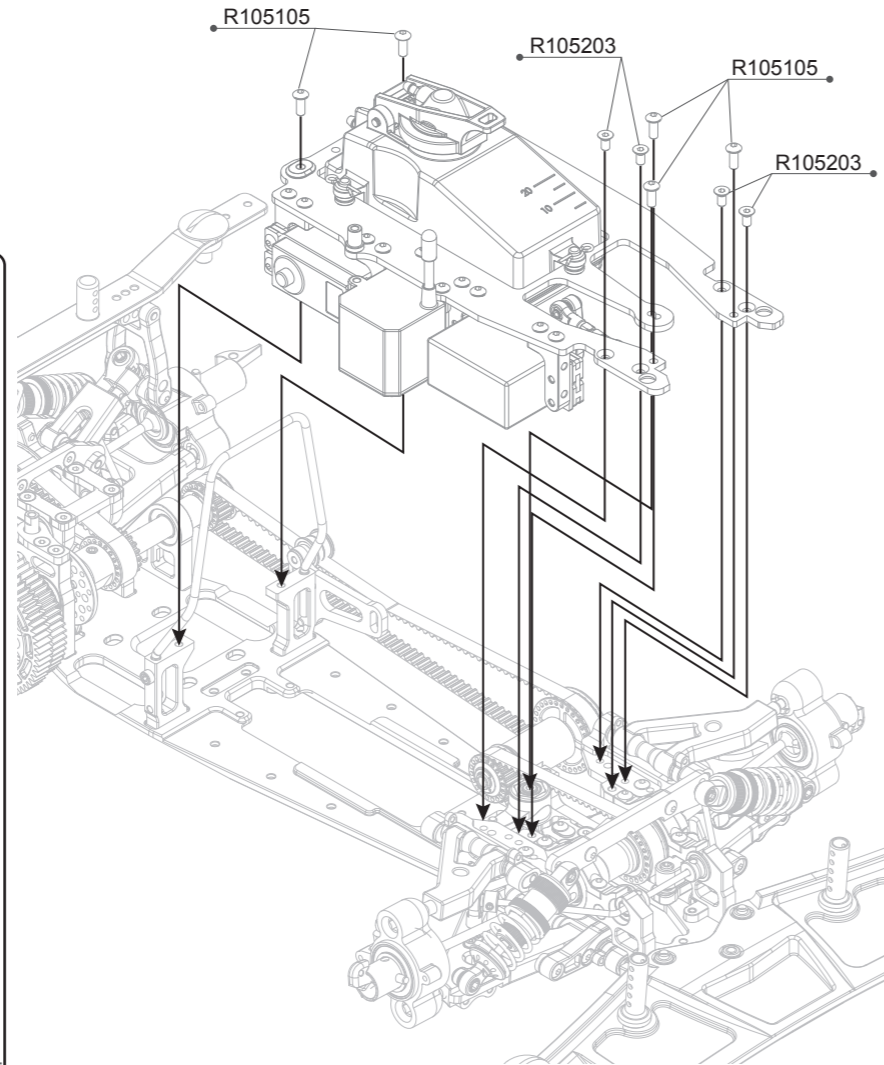

Option Parts (Not Included) / 改裝品(未附於套件內)

R838003 R8.3 Upper stifener Plate

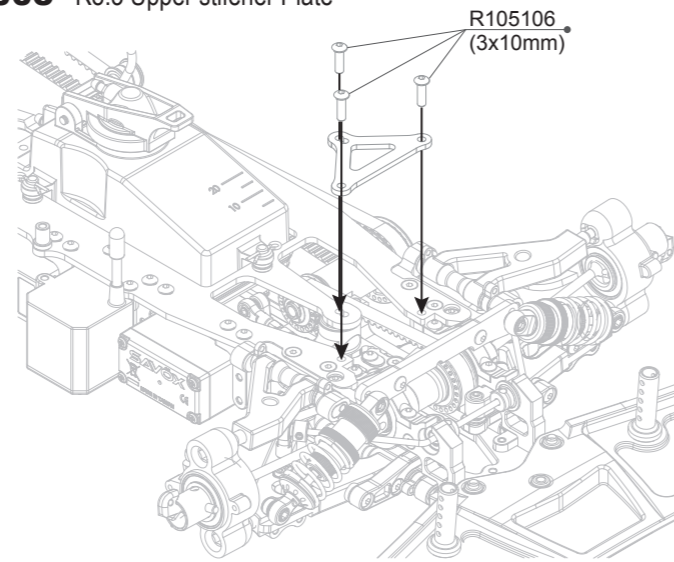

-  **R805010**
3x5mm Flat Screw (10)

1:1 Scale

NiMH/Lipo Receiver Battery
(Not Included)

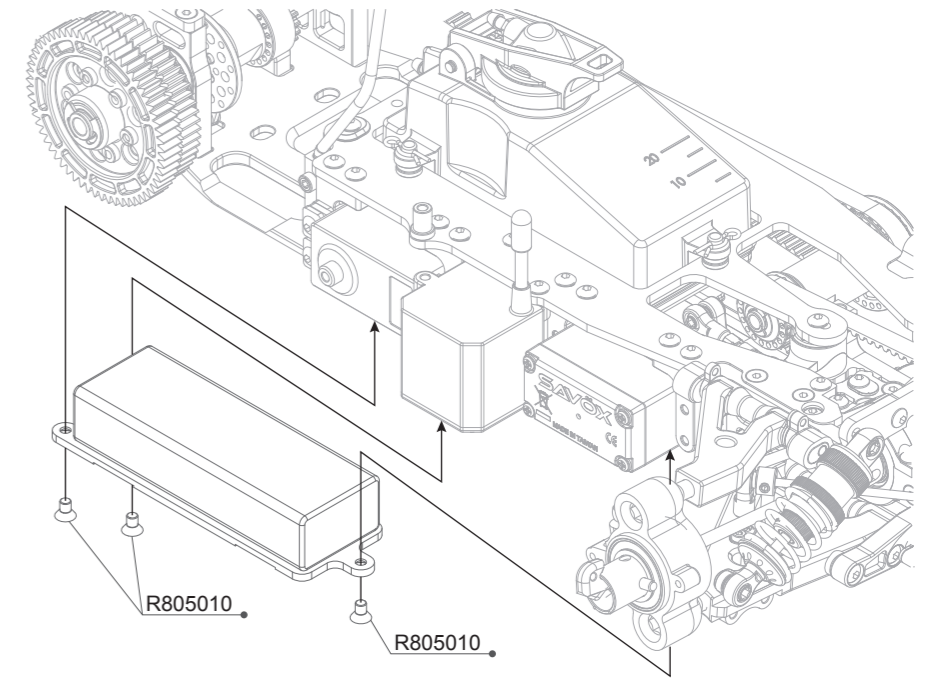
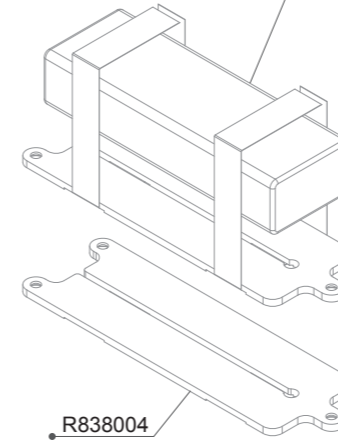

R805010 3x5mm Flat Screw (10)

R838004 R8.3 Flex Battery Plate

-  **R805304**
3x12mm Cap Screw (10)

1:1 Scale

NOTICE

Step 1

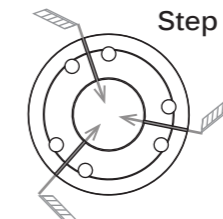

Cut the fly weight.
依圖示將甩片切開

NOTICE

Step 2 Pin



Install the clutch fly weights into the fly wheel as pictured above.
依圖示方向安裝甩片。

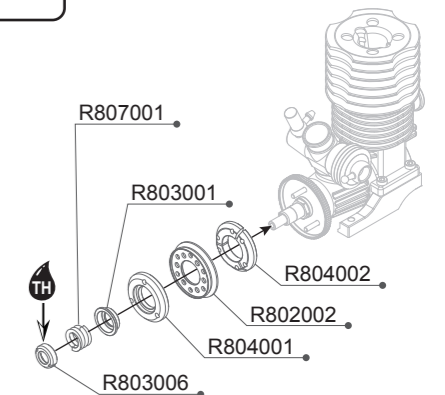
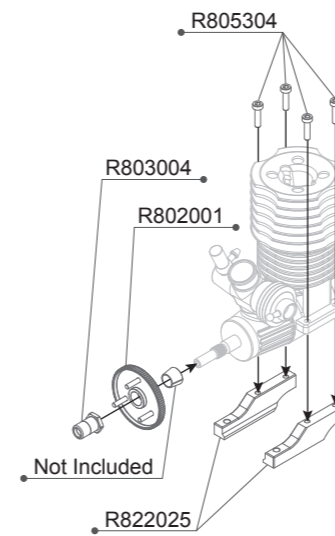

- R802001 Fly Wheel
- R802002 Clutch Pad Base
- R803001 Clutch Spring Base-Steel
- R803004 Fly Wheel Nut
- R803006 Clutch Spring Nut

- R804001 Clutch Pad Yellow
- R804002 Clutch Fly Weight
- R805304 3x12mm Cap Screw (10)
- R807001 Clutch Spring 2.0mm
- R822025 R8.2 LCG Engine Mount-Alu

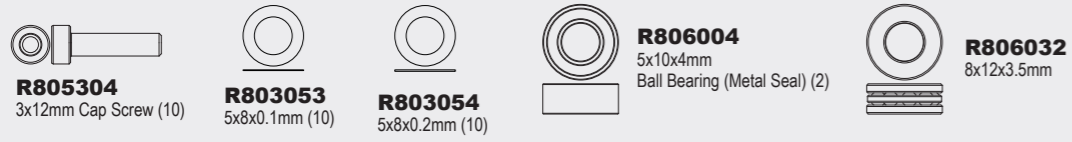

1:1 Scale

Option Parts (Not Included) / 改裝品 (未附於套件內)

- R802068** 1st Gear Pinion 17T
- R802069** 1st Gear Pinion 18T
- R802071** 1st Gear Pinion 20T

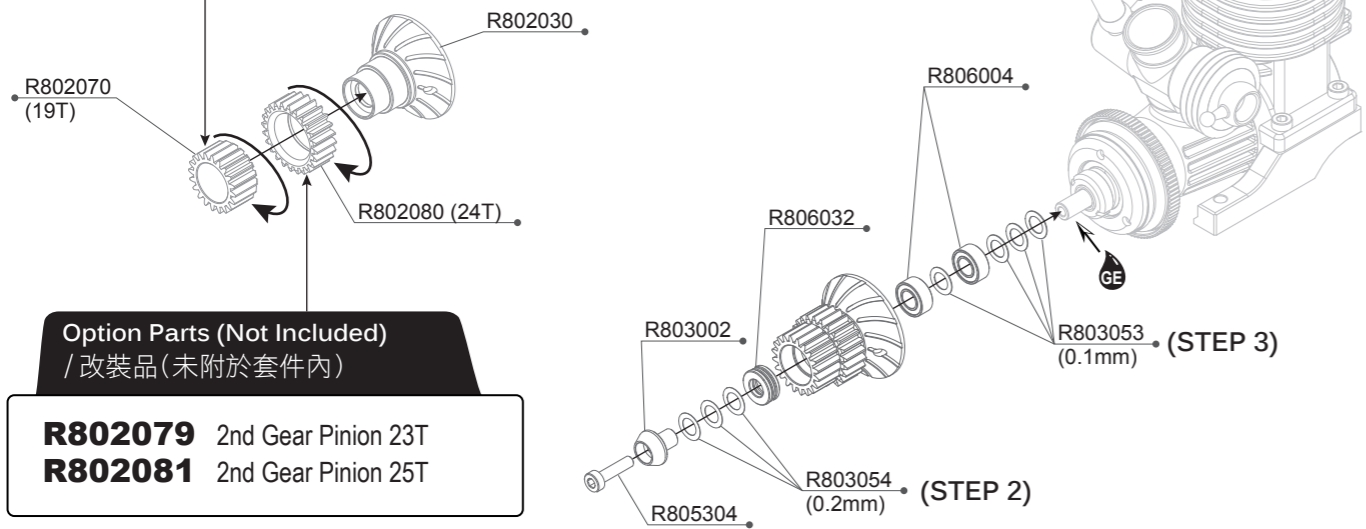

Option Parts (Not Included) / 改裝品 (未附於套件內)

- R802079** 2nd Gear Pinion 23T
- R802081** 2nd Gear Pinion 25T

NOTICE		
STEP 1	STEP 2	STEP 3
<p>0.1~0.9mm</p>	<p>Push Pull</p> <p>A B</p> <p>$(A \leftrightarrow C) - (A \leftrightarrow B) = 0.6 \sim 0.7 \text{MM}$</p>	
<p>Set to 0.1mm to break-in the clutch pad & bell. After break-in, tighten to 0.6mm-0.9mm for race setting.</p> <p>彈簧的壓力請設定在0.1mm用來磨合離合器，磨合之後依所需的力道可鎖到0.6mm~0.9mm，鎖越多力道越大。</p>	<p>Adjust the Clutch Gap A-B by add / remove R803054 Shims and set the clearance of gap into 0.5mm.</p> <p>於箭頭處加入或移除R803054墊片使A與B的距離為0.5mm。</p>	<p>After step 2 is finished, add the distance shims (0.6mm-0.7mm) back to shaft to keep clutch bell not touching the pad.</p> <p>上述之間隙調整完成後，再將離合器罩拆開並於箭頭處加入墊片直到離合器罩不會接觸到離合器片。</p>

- R802030 Clutch Bell -Alu
- R802070 1st Gear Pinion 19T
- R802080 2nd Gear Pinion 24T
- R803002 Clutch Bearing Nut
- R803053 5x8x0.1mm Shims (10)
- R803054 5x8x0.2mm Shims (10)
- R805304 3x12mm Cap Screw (10)
- R806004 5x10x4 Ball Bearing (2)
- R806032 5x8x4 Thrust Ball Bearing



1:1 Scale

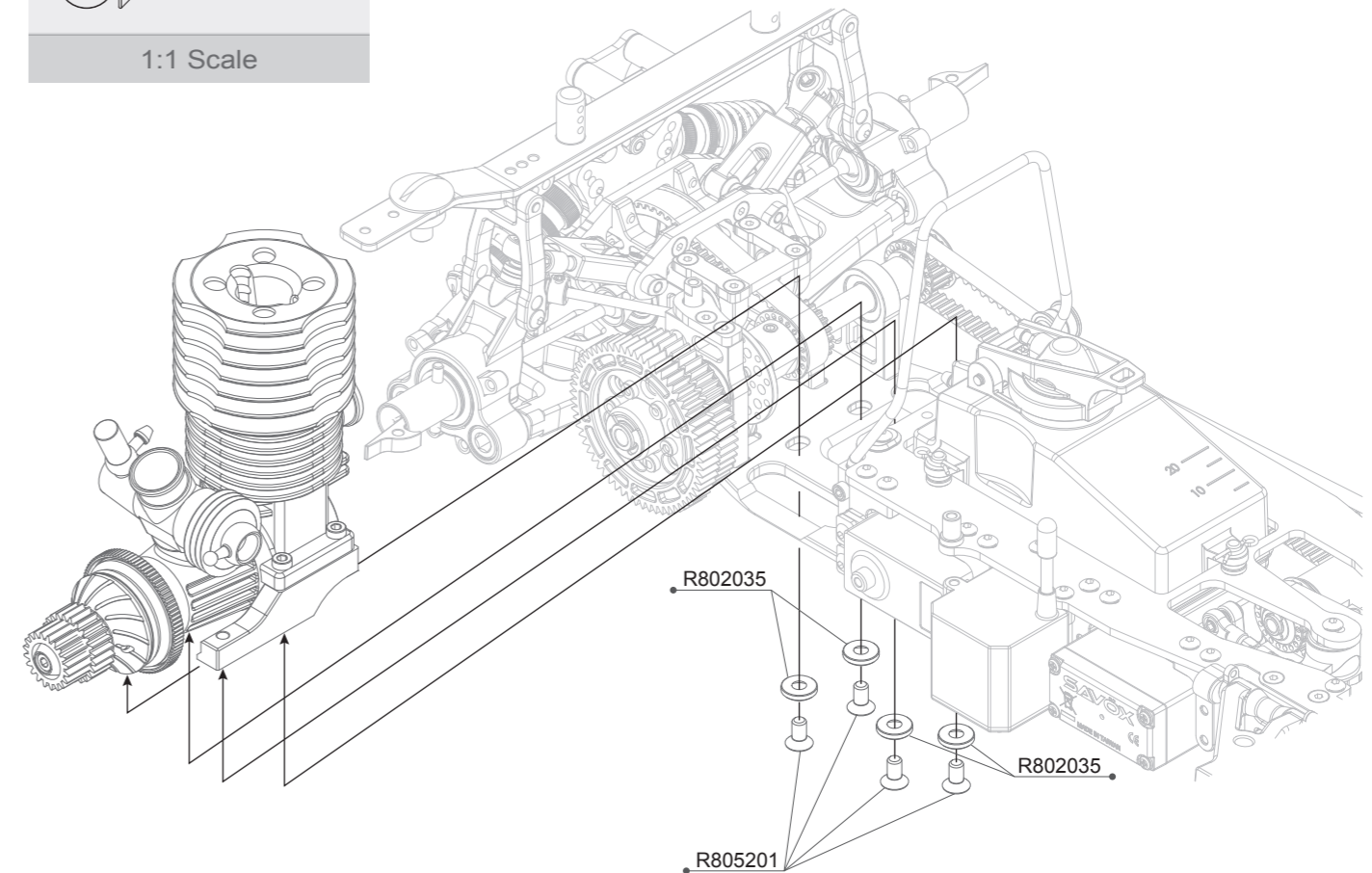









NOTICE

Please setup the gear mesh well to avoid spur/pinion friction or strip.
請將齒隙調整到調當的位置以防止齒輪於行進中損毀。

- R802035 4mm Sink Shims Alu (4)

- R805201 4x8mm Flat Screw (10)

-  **R105103**
3x4 Round Screw (10)
-  **R105104**
3x6 Round Screw (10)
-  **R105106**
3x10 Round Screw (10)
-  **R105107**
3x12 Round Screw (10)
-  **R105401**
3x3mm Set Screw (10)
-  **R105404**
3x10mm Set Screw (10)
-  **R102020**
3x6x0.5mm Alu Shims (8)
-  **R105150**
3mm Nylon Nut (10)
-  **R106010**
5x8x2.5mm Ball Bearing (4)

1:1 Scale

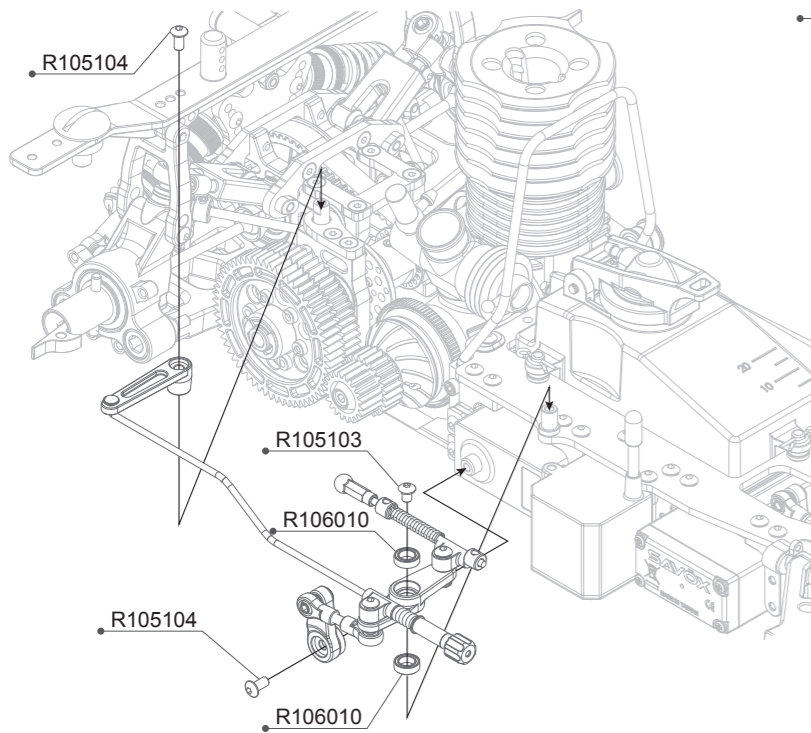
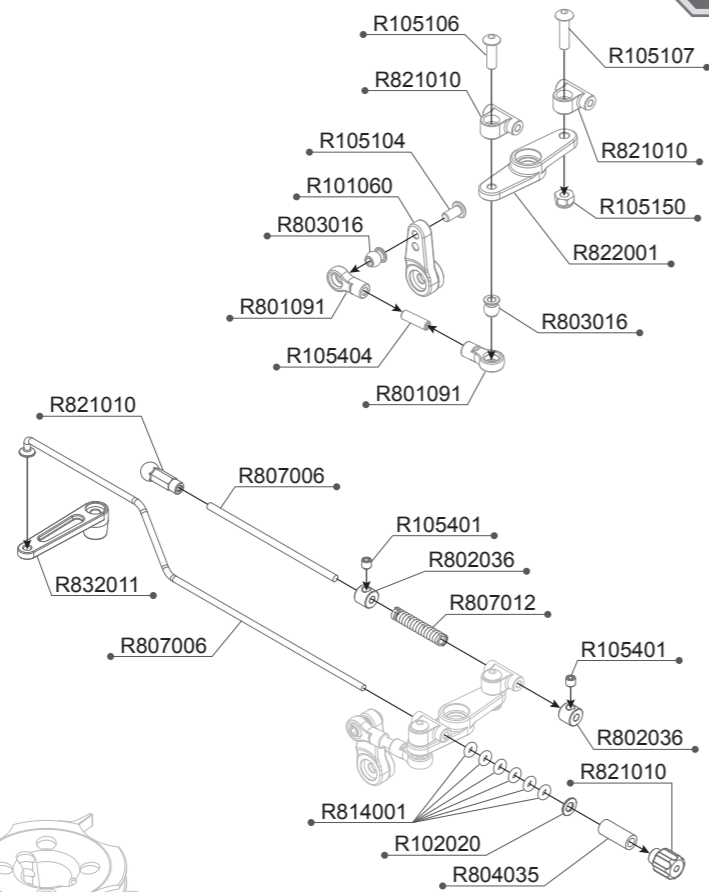

NOTICE

Make linkage base moving smooth.
連桿基座必須活動順暢。

- R101060 Servo Horn Dual steering arm
- R102020 3x6x0.5mm Alu Shims(8pcs)
- R105103 3x4 Round Screw (10)
- R105104 3x6 Round Screw (10)
- R105106 3x10 Round Screw (10)
- R105107 3x12 Round Screw (10)
- R105150 3mm Nylon Nut (10)
- R105401 3x3mm Set Screw (10)
- R105404 3x10mm Set Screw (10)
- R106010 5x8x2.5mm Ball Bearing (4)

- R801091 Ball End 4.9mm Short (2)
- R802036 Collar Alu(4pcs)
- R803016 Ball Head 4.9mm (4)
- R804035 Fuel Tube 90cm
- R807006 Throttle Linkage (2)
- R807012 Throttle Spring (2)
- R814001 2x1.5 O'ring (6)
- R821010 R8.2 Throttle Lever Connector
- R822001 R8.2 Throttle Lever-Alu
- R832011 R8.3 Brake Lever

-  **R805050**
4x4mm Set Screw (10)

1:1 Scale

NOTICE

Pipe Not Included
套件中不含排氣管

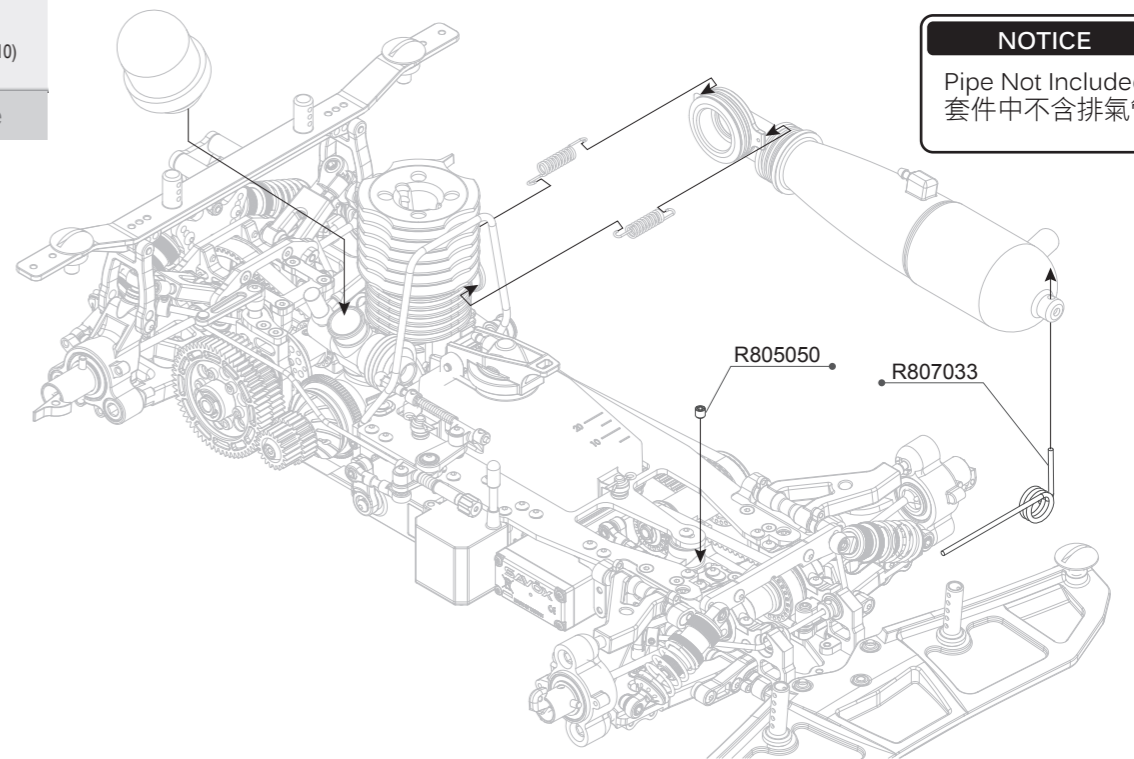

R805050 4x4mm Set Screw (10)

R807033 Exhaust Pipe Spring

NOTICE

Tire Not Included
套件中不含輪胎

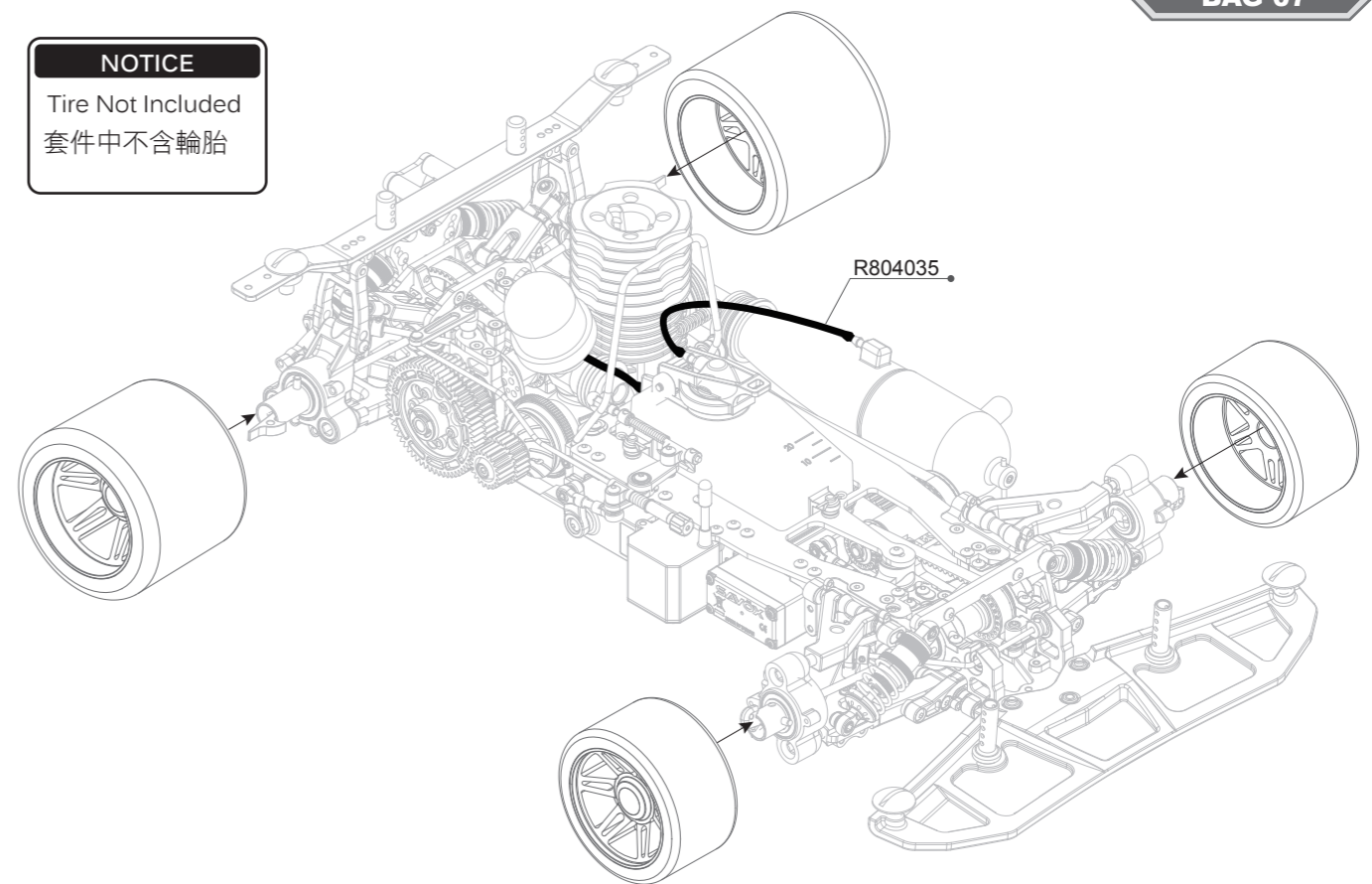

R804035 Fuel Tube 90cm

R8.3 BAG 07 PARTS EXPLORE VIEW

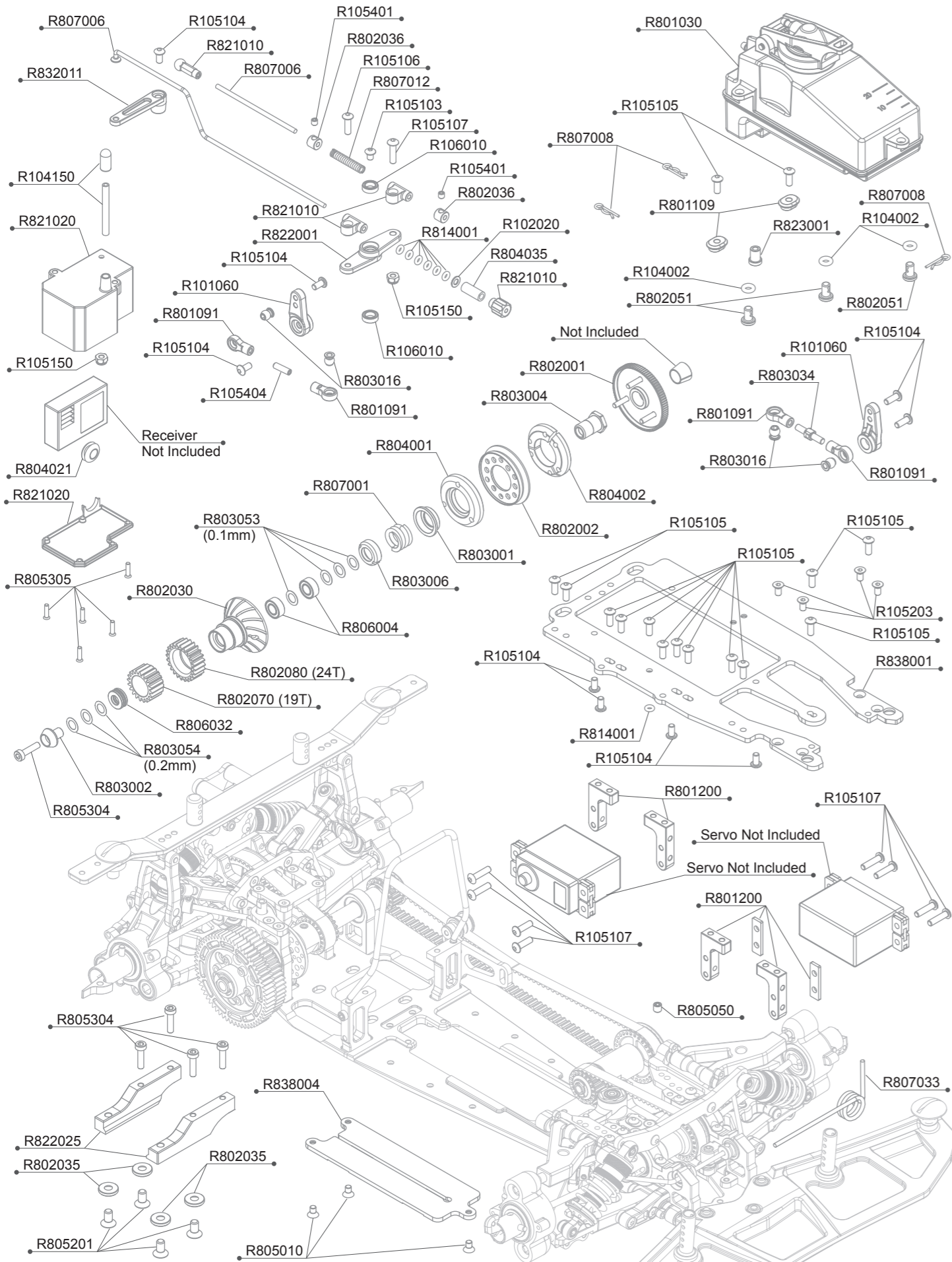

R8.3 BAG 07 PARTS LIST

R101060	Servo Horn Dual steering arm	R803016	Ball Head 4.9mm (4)
R102020	3x6x0.5mm Alu Shims(8pcs)	R803034	3mm X 15mm Turnbuckle
R104002	O'ring 3x2(4pcs)	R803053	5x8x0.1mm Shims (10)
R104150	Antenna (1set)	R803054	5x8x0.2mm Shims (10)
R105103	3x4 Round Screw (10)	R804001	Clutch Pad Yellow
R105104	3x6 Round Screw (10)	R804002	Clutch Fly Weight
R105105	3x8 Round Screw (10)	R804021	Rubber Grommet (2)
R105106	3x10 Round Screw (10)	R804035	Fuel Tube 90cm
R105107	3x12 Round Screw (10)	R805010	3x5mm Flat Screw (10)
R105150	3mm Nylon Nut (10)	R805050	4x4mm Set Screw (10)
R105203	3x6mm Flat Screw (10)	R805201	4x8mm Flat Screw (10)
R105401	3x3mm Set Screw (10)	R805304	3x12mm Cap Screw (10)
R105404	3x10mm Set Screw (10)	R805305	2x8mm Flat Screw (10)
R106010	5x8x2.5mm Ball Bearing (4pcs)	R806004	5x10x4 Ball Bearing (2)
R801030	Fuel Tank with insert	R806032	5x8x4 Thrust Ball Bearing
R801091	Ball End 4.9mm Short (2)	R807001	Clutch Spring 2.0mm
R801109	Upper Deck Insert (2)	R807006	Throttle Linkage (2)
R801200	Servo Mount Set	R807008	3mm R Clip (10)
R802001	Fly Wheel	R807012	Throttle Spring (2)
R802002	Clutch Pad Base	R807033	Exhaust Pipe Spring
R802030	Clutch Bell -Alu	R814001	2x1.5 O'ring (6)
R802035	4mm Sink Shims Alu (4)	R821010	R8.2 Throttle Lever Connector
R802036	Collar Alu(4pcs)	R821020	R8.2 Radio Box
R802051	Fuel Tank Mount (3)	R822001	R8.2 Throttle Lever-Alu
R802070	1st Gear Pinion 19T	R822025	R8.2 LCG Engine Mount-Alu
R802080	2nd Gear Pinion 24T	R823001	Throttle Lever Base
R803001	Clutch Spring Base-Steel	R832011	R8.3 Brake Lever
R803002	Clutch Bearing Nut	R838001	R8.3 Upper Deck
R803004	Fly Wheel Nut	R838004	R8.3 Flex Battery Plate
R803006	Clutch Spring Nut		

1:1 SCALE

	R105103 3x4 Round Screw (10)		R805010 3x5mm Flat Screw (10)		R105150 3mm Nylon Nut (10)
	R105104 3x6 Round Screw (10)		R105203 3x6mm Flat Screw (10)		R106010 5x8x2.5mm Ball Bearing (4)
	R105105 3x8 Round Screw (10)		R805201 4x8mm Flat Screw (10)		R806004 5x10x4 Ball Bearing (Metal Seal) (2)
	R105106 3x10 Round Screw (10)		R105401 3x3mm Set Screw (10)		R806032 8x12x3.5mm
	R105107 3x12 Round Screw (10)		R105404 3x10mm Set Screw (10)		
	R805305 2x8mm Flat Screw (10)		R805050 4x4mm Set Screw (10)		
	R805304 3x12mm Cap Screw (10)		R102020 3x6x0.5mm Alu Shims (8)		