

DRIVER, TRACK AND RESULTS

DRIVER _____ **COUNTRY** _____ **WEATHER** AIR TEMP _____ TRACK TEMP _____ DRY INTERMEDIATE WET
RACE _____ **DATE** _____ **QUALY POS.** _____ **STARTING POS.** _____ **FINAL POS.** _____ **FASTEST LAP** _____
TRACK _____ **TYPE** TIGHT MEDIUM OPEN **GRIP** LOW MEDIUM HIGH
SURFACE CONDITION SMOOTH ROUGH
TYPE HARD PACKED CLAY MULTI/SURFACE GRASS BLUE GROOVE DIRT ASTRO-TURF

FRONT SHOCK ABSORBERS		REAR	
cst	OIL		cst
SPRINGS			
mm	REBOUND		mm
N° HOLES	Ø	mm	PISTONS N° HOLES Ø
<input type="checkbox"/> STRAIGHT <input type="checkbox"/> ANGLED	HOLES TYPE	<input type="checkbox"/> STRAIGHT <input type="checkbox"/> ANGLED	
<input type="checkbox"/> BLADDER	SEAL	<input type="checkbox"/> BLADDER	
<input type="checkbox"/> EMULSION	TYPE	<input type="checkbox"/> EMULSION	

ANTI-ROLL BARS

FRONT ANTI-ROLL BAR	mm	REAR ANTI-ROLL BAR	mm
---------------------	----	--------------------	----

DIFFERENTIALS

FRONT DIFF	CENTER DIFF	REAR DIFF
<input type="checkbox"/> HTD <input type="checkbox"/> STD	<input type="checkbox"/> HTD <input type="checkbox"/> STD	<input type="checkbox"/> HTD <input type="checkbox"/> STD
cst	cst	cst

ELECTRONICS & GEARING

MOTOR & PINION			
BRAND	TYPE		
TIMMING	PINION		
teeth			
ESC			
BRAND	TYPE		
BATTERY			
BRAND	CAPACITY		
mAh			
<input type="checkbox"/> 4S BRICK BATTERY	<input type="checkbox"/> 2S STICK BATTERIES	<input type="checkbox"/> 2S SHORTY REARWARD BATTERIES	<input type="checkbox"/> 2S SHORTY FORWARD BATTERIES

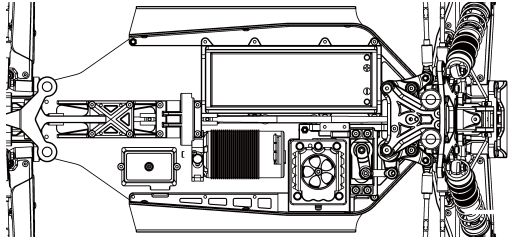

WHEEL BASE

SHORT WHEELBASE LONG WHEELBASE

AERODYNAMIC CONFIGURATION

BODY STANDARD HIGH DOWNFORCE OTHER _____
WING
 TYPE _____ WING PLATES 2° 4° 6°
 GURNEY STRIP YES NO CENTER FOIL YES NO

FRONT TIRES	Controlled Tire	REAR
MAKE		
TYPE		
INSERTS		
WHEELS		

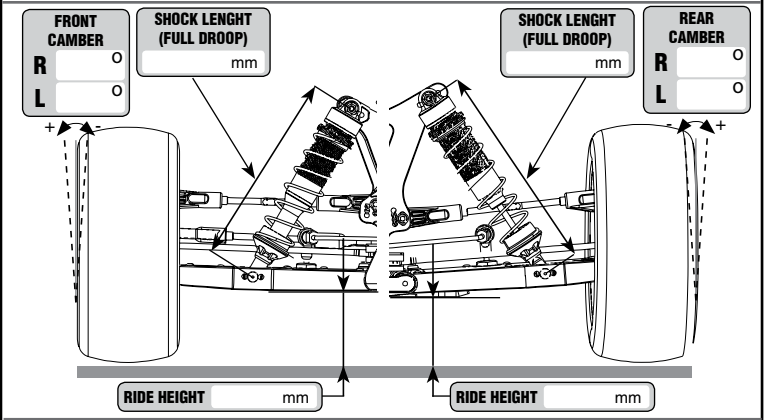
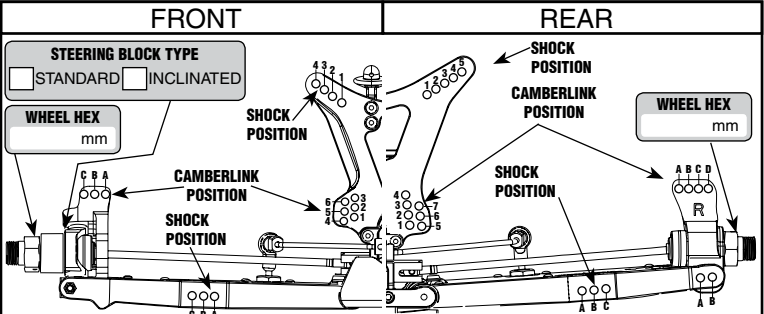

FRONT ARM SKIN	REAR ARM SKIN
<input type="checkbox"/> YES <input type="checkbox"/> NO <input type="checkbox"/> NYLON <input type="checkbox"/> CARBON	<input type="checkbox"/> YES <input type="checkbox"/> NO <input type="checkbox"/> NYLON <input type="checkbox"/> CARBON

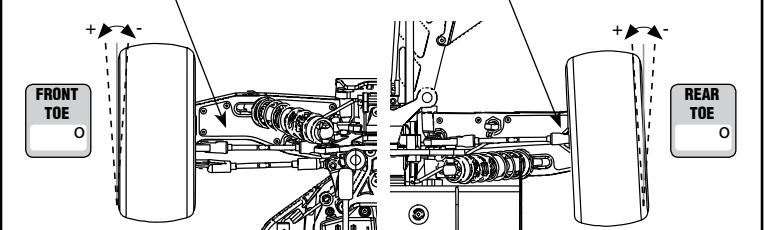

STEERING BLOCK ACKERMAN PLATE	REAR HUB TYPE
OPTION TYPE _____	<input type="checkbox"/> NYLON <input type="checkbox"/> ALU
	REAR HUB ROLL CENTER INSERTS (ALU REAR HUB)

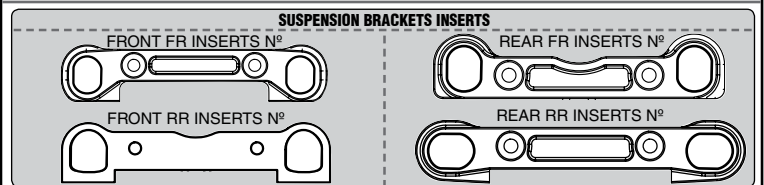
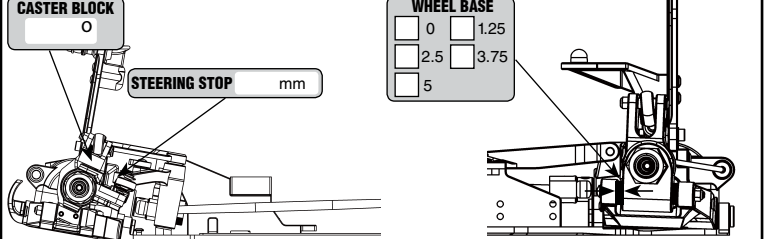

REMARKS