

Front Suspension:

Ride Height: _____
 Camber: _____
 Toe: _____
 Anti-Roll Bar: _____
 Arm Type: _____
 Tower Type: _____
 Wheel Hex: _____
 Steering Block: _____
 Caster Block Insert: _____
 Bulkhead Type: _____
 Kick-Up Angle: _____
 Notes: _____

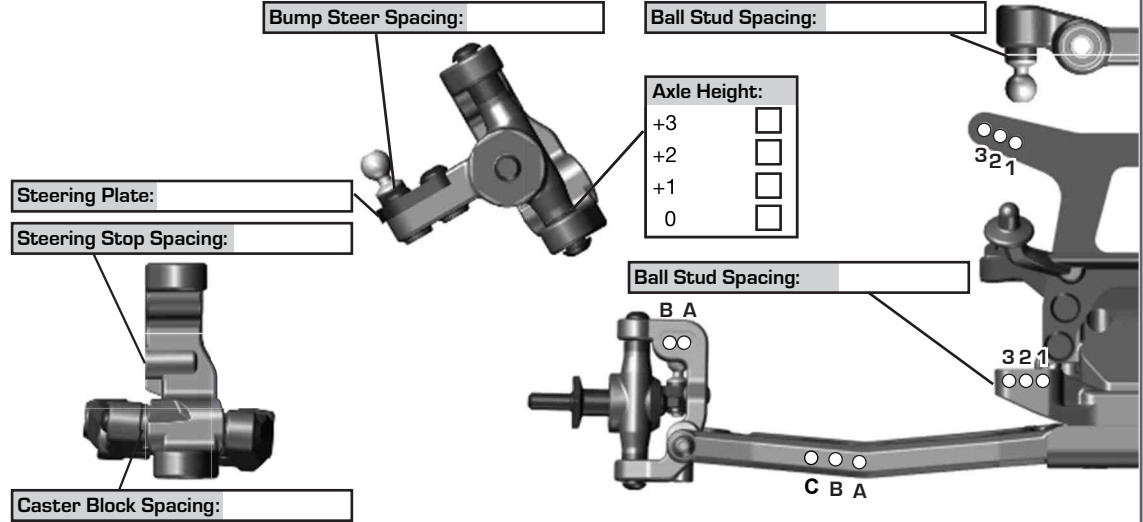

Rear Suspension:

Ride Height: _____
 Camber: _____
 Anti-Roll Bar: _____
 Arm Type: _____
 Tower Type: _____
 Arm Spacing: _____
 Wheel Hex: _____
 Shock Mounting Position:
 Front of Arm Rear of Arm
 Hub Spacing: Fwd Mid Back
 Notes: _____

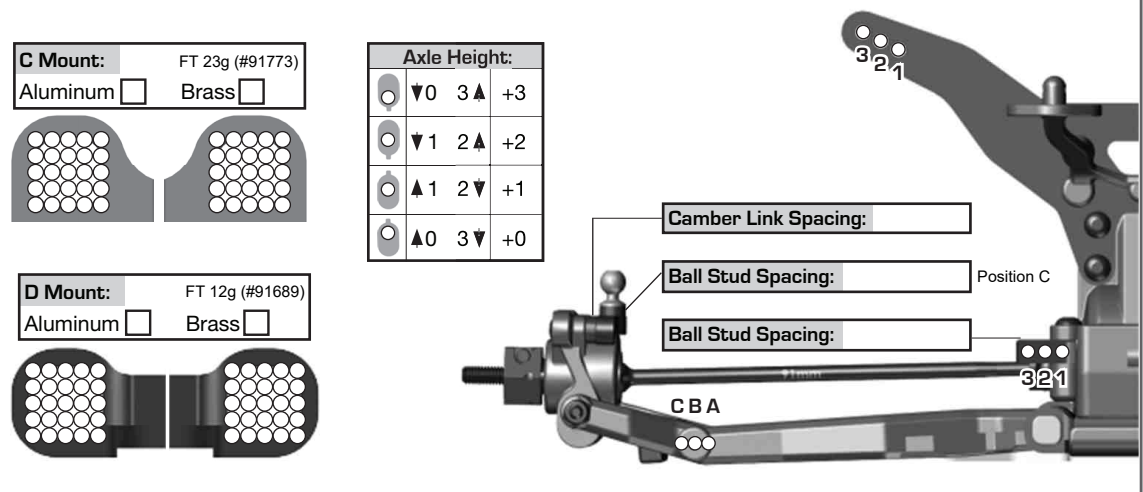

Electronics:

Radio: _____ Servo: _____
 EPA: Throttle: _____ % Brake: _____ %
 ESC: _____
 ESC Settings: _____
 Motor: _____
 Wind: _____ Timing: _____
 Pinion: _____ Spur: _____
 Battery: _____
 Battery Position: _____
 Battery Weight: _____

Drivetrain:

Transmission: Laydown:
 Stand Up: Layback:
 Differential: Ball Diff:
 Height: _____ Gear Diff:
 Gear Diff Mass: _____
 Notes: _____
Slipper Clutch:
 Type: _____
 # of Pads: _____
 Setting: _____

Shocks:

	Front	Rear
Piston:	_____	_____
Fluid:	_____	_____
Spring:	_____	_____
Limiters:	Int: _____ Ext: _____	Int: _____ Ext: _____
Stroke:	_____	_____
Eyelet Length:	_____	_____
Cup Offset:	_____	_____
Notes:	_____	

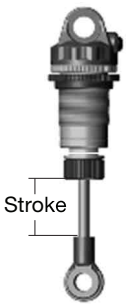

Track Info:

Size: Small Medium Large Extra Large
 Surface: Dirt Carpet Astroturf Multi Surface
 Traction: Low Medium High Very High
 Moisture: Dry Damp Wet
 Condition: Indoor Outdoor Dusty Hard Packed
 Bumpy Grooved Smooth Loamy
 Temperature: Ambient: _____ Track: _____
 Notes: _____
 Vehicle Comments: _____

Tires:

Front Tires: _____
 Front Compound: _____
 Front Insert: _____
 Rear Tires: _____
 Rear Compound: _____
 Rear Insert: _____
 Wheel (F/R): _____
 Notes: _____

Body, Weight:

Body: _____
 Spoiler: _____
 Servo Weights: _____
 Electronic Weights: _____
 Total Vehicle Weight: _____
 Notes: _____