

1/8 LUXURY GT

XRAY GTX8



INSTRUCTION MANUAL

GTX8'23

BEFORE YOU START

This is a high-competition, high-quality RC car intended for persons aged 16 years and older with previous experience building and operating RC model racing cars. This is not a toy; it is a precision racing model. This model racing car is not intended for use by beginners, inexperienced customers, or by children without direct supervision of a responsible, knowledgeable adult. If you do not fulfill these requirements, please return the kit in unused and unassembled form back to the shop where you have purchased it.

Before building and operating your XRAY, **YOU MUST** read through all of the operating instructions and instruction manual and fully understand them to get the maximum enjoyment and prevent unnecessary damage. Read

carefully and fully understand the instructions before beginning assembly.

Make sure you review this entire manual, download and use set-up book from the web, and examine all details carefully. If for some reason you decide this is not what you wanted or expected, **do not continue any further**. Your hobby dealer can not accept your kit for return or exchange after it has been partially or fully assembled.

Contents of the box may differ from pictures. In line with our policy of continuous product development, the exact specifications of the kit may vary without prior notice.

CUSTOMER SUPPORT

We have made every effort to make these instructions as easy to understand as possible. However, if you have any difficulties, problems, or questions, please do not hesitate to contact the XRAY support team at info@teamxray.com. Also, please visit our Web site at www.teamxray.com to find the latest updates, set-up information, option parts, and many other goodies. We pride ourselves on taking excellent care of our customers.

You can join thousands of XRAY fans and enthusiasts in our online community at: **www.teamxray.com**

XRAY Europe

K Výstavisku 6992
91101 Trenčín
Slovakia, EUROPE
Phone: +421-32-7401100
Fax: +421-32-7401109
Email: info@teamxray.com

XRAY USA

RC America, 2030 Century Center Blvd #15
Irving, TX 75062
USA
Phone: (214) 744-2400
Fax: (214) 744-2401
Email: xray@rcamerica.com

FAILURE TO FOLLOW THESE INSTRUCTIONS WILL BE CONSIDERED AS ABUSE AND/OR NEGLECT.

SAFETY PRECAUTIONS

WARNING: This product contains a chemical known to the state of California to cause cancer and birth defects or other reproductive harm.

CAUTION: CANCER HAZARD

Wash thoroughly after using. DO NOT use product while eating, drinking or using tobacco products. May cause chronic effects to gastrointestinal tract, CNS, kidneys, and blood. **MAY CAUSE BIRTH DEFECTS.**

When building, using and/or operating this model always wear protective glasses and gloves.

Take appropriate safety precautions prior to operating this model. You are responsible for this model's assembly and safe operation! Please read the instruction manual before building and operating this model and follow all safety precautions. Always keep the instruction manual at hand for quick reference, even after completing the assembly. Use only genuine and original authentic XRAY parts

for maximum performance. Using any third party parts on this model will void warranty immediately.

Improper operation may cause personal and/or property damage. XRAY and its distributors have no control over damage resulting from shipping, improper construction, or improper usage. XRAY assumes and accepts no responsibility for personal and/or property damages resulting from the use of improper building materials, equipment and operations. By purchasing any item produced by XRAY, the buyer expressly warrants that he/she is in compliance with all applicable federal, state and local laws and regulation regarding the purchase, ownership and use of the item. The buyer expressly agrees to indemnify and hold harmless XRAY for all claims resulting directly or indirectly from the purchase, ownership or use of the product. By the act of assembling or operating this product, the user accepts all resulting liability. If the buyer is not prepared to accept this liability, then he/she should return this kit in new, unassembled, and unused condition to the place of purchase.

IMPORTANT NOTES - GENERAL

- This product is not suitable for children under 16 years of age without the direct supervision of a responsible and knowledgeable adult.
- Carefully read all manufacturers warnings and cautions for any parts used in the construction and use of your model.
- Assemble this kit only in places away from the reach of very small children.
- First-time builders and users should seek advice from people who have building experience in order to assemble the model correctly and to allow the model to reach its performance potential.
- Exercise care when using tools and sharp instruments.
- Take care when building, as some parts may have sharp edges.
- Keep small parts out of reach of small children. Children must not be allowed to put any parts in their mouth, or pull vinyl bag over their head.
- Read and follow instructions supplied with paints and/or cement, if used (not included in kit).
- Immediately after using your model, do NOT touch equipment on the model such as the motor and speed controller, because they generate high temperatures. You may seriously burn yourself seriously touching them.
- Follow the operating instructions for the radio equipment at all times.
- Do not put fingers or any objects inside rotating and moving parts, as this may cause damage or serious injury as your finger, hair, clothes, etc. may get caught.
- Be sure that your operating frequency is clear before turning on or running your model, and never share the same frequency with somebody else at the same time. Ensure that others are aware of the operating frequency you are using and when you are using it.
- Use a transmitter designed for ground use with RC cars. Make sure that no one else is using the same frequency as yours in your operating area. Using the same frequency at the same time, whether it is driving, flying or sailing, can cause loss of control of the RC model, resulting in a serious accident.
- Always turn on your transmitter before you turn on the receiver in the car. Always turn off the receiver before turning your transmitter off.
- Keep the wheels of the model off the ground when checking the operation of the radio equipment.
- Disconnect the battery pack before storing your model.
- When learning to operate your model, go to an area that has no obstacles that can damage your model if your model suffers a collision.
- Remove any sand, mud, dirt, grass or water before putting your model away.
- If the model behaves strangely, immediately stop the model, check and clear the problem.
- To prevent any serious personal injury and/or damage to property, be responsible when operating all remote controlled models.
- The model car is not intended for use on public places and roads or areas where its operation can conflict with or disrupt pedestrian or vehicular traffic.
- Because the model car is controlled by radio, it is subject to radio interference from many sources that are beyond your control. Since radio interference can cause momentary loss of control, always allow a safety margin in all directions around the model in order to prevent collisions.
- Do not use your model:
 - Near real cars, animals, or people that are unaware that an RC car is being driven.
 - In places where children and people gather
 - In residential districts and parks
 - In limited indoor spaces
 - In wet conditions
 - In the street
 - In areas where loud noises can disturb others, such as hospitals and residential areas.
 - At night or anytime your line of sight to the model may be obstructed or impaired in any way.

To prevent any serious personal injury and/or damage to property, please be responsible when operating all remote controlled models.

IMPORTANT NOTES - NITRO ENGINES

- Always test the brakes and the throttle before starting your engine to avoid losing control of the model.
- Make sure the air filter is clean and oiled.
- Never run your engine without an air filter. Your engine can be seriously damaged if dirt and debris get inside the engine.
- For proper engine break-in, please refer to the manual that came with the engine.
- Do not run near open flames or smoke while running your model or while handling fuel.
- Some parts will be hot after operation. Do not touch the exhaust or the engine until they have cooled. These parts may reach 275°F during operation!

IMPORTANT NOTES - ELECTRICAL

- Insulate any exposed electrical wiring (using heat shrink tubing or electrical tape) to prevent dangerous short circuits. Take maximum care in wiring, connecting and insulating cables. Make sure cables are always connected securely. Check connectors for if they become loose. And if so, reconnect them securely. Never use R/C models with damaged wires. A damaged wire is extremely dangerous, and can cause short-circuits resulting in fire. Please have wires repaired at your local hobby shop.
- Low battery power will result in loss of control. Loss of control can occur due to a weak battery in either the transmitter or the receiver. Weak running battery may also result in an out of control car if your car's receiver power is supplied by the running battery. Stop operation immediately if the car starts to slow down.
- When not using RC model, always disconnect and remove battery.
- Do not disassemble battery or cut battery cables. If the running battery short-circuits, approximately 300W of electricity can be discharged, leading to fire or burns. Never disassemble battery or cut battery cables.
- Use a recommended charger for the receiver and transmitter batteries and follow the instructions correctly. Over-charging, incorrect charging, or using

inferior chargers can cause the batteries to become dangerously hot. Recharge battery when necessary. Continual recharging may damage battery and, in the worst case, could build up heat leading to fire. If battery becomes extremely hot during recharging, please ask your local hobby shop for check and/or repair and/or replacement.

- Regularly check the charger for potential hazards such as damage to the cable, plug, casing or other defects. Ensure that any damage is rectified before using the charger again. Modifying the charger may cause short-circuit or overcharging leading to a serious accident. Therefore do not modify the charger.
- Always unplug charger when recharging is finished.
- Do not recharge battery while battery is still warm. After use, battery retains heat. Wait until it cools down before charging.
- Do not allow any metal part to short circuit the receiver batteries or other electrical/electronic device on the model.
- Immediately stop running if your RC model gets wet as may cause short circuit.
- Please dispose of batteries responsibly. Never put batteries into fire.

IMPORTANT NOTES - NITRO FUEL

- Handle fuel only outdoors. Never handle nitro fuel indoors, or mix nitro fuel in a place where ventilation is bad.
- Only use nitro fuel for R/C models. Do not use gasoline or kerosene in R/C models as it may cause a fire or explosion, and ruin your engine.
- Nitro fuel is highly flammable, explosive, and poisonous. Never use fuel indoors or in places with open fires and sources of heat.
- Always keep the fuel container cap tightly shut.
- Always read the warning label on the fuel container for safety information.
- Nitro-powered model engines emit poisonous vapors and gasses. These vapors irritate eyes and can be highly dangerous to your health. We recommend wearing rubber or vinyl gloves to avoid direct contact with nitro fuel.
- Nitro fuel for RC model cars is made of the combination of the methyl alcohol,

castor or synthetic oil, nitro methane etc. The flammability and volatility of these elements is very high, so be very careful during handling and storage of nitro fuel.

- Keep nitro fuel away from open flame, sources of heat, direct sunlight, high temperatures, or near batteries.
- Store fuel in a cool, dry, dark, well-ventilated place, away from heating devices, open flames, direct sunlight, or batteries. Keep nitro fuel away from children.
- Do not leave the fuel in the carburetor or fuel tank when the model is not in use. There is danger that the fuel may leak out.
- Wipe up any spilled fuel with a cloth.
- Be aware of spilled or leaking fuel. Fuel leaks can cause fires or explosions.
- Do not dispose of fuel or empty fuel containers in a fire. There is danger of explosion.

R/C & BUILDING TIPS

- Make sure all fasteners are properly tightened. Check them periodically.
- Make sure that chassis screws do not protrude from the chassis.
- For the best performance, it is very important that great care is taken to ensure the free movement of all parts.
- Clean all ball-bearings so they move very easily and freely.
- Tap or pre-thread the plastic parts when threading screws.
- Self-tapping screws cut threads into the parts when being tightened. Do not use excessive force when tightening the self-tapping screws because you may strip out the thread in the plastic. We recommended you stop tightening a screw when you feel some resistance.

- Ask your local hobby shop for any advice.

Please support your local hobby shop. We at XRAY Model Racing Cars support all local hobby dealers. Therefore we ask you, if at all possible, to purchase XRAY products at your hobby dealer and give them your support like we do. If you have difficulty finding XRAY products, please check out www.teamxray.com to get advice, or contact us via email at info@teamxray.com, or contact the XRAY distributor in your country.

WARRANTY

XRAY guarantees this model kit to be free from defects in both material and workmanship within 30 days of purchase. The total monetary value under warranty will in no case exceed the cost of the original kit purchased. This warranty does not cover any components damaged by use or modification or as a result of wear. Part or parts missing from this kit must be reported within 30 days of purchase. No part or parts will be sent under warranty without proof of purchase. Should you find a defective or missing part, contact the local distributor. Service and customer support will be provided through local hobby store where you have purchased the kit, therefore make sure to purchase any XRAY products at your local hobby store. This model racing car is considered to be a high-performance racing vehicle. As such this vehicle will be used in an extreme range of conditions and situations, all which may cause premature wear or failure of any component. XRAY has no control over usage of vehicles once they leave the dealer, therefore XRAY can only offer warranty against all manufacturer's defects in materials, workmanship, and assembly at point of sale and before use. No warranties are expressed or implied that cover damage caused by what is considered normal use, or cover or imply how long any model cars' components or electronic components will last before requiring replacement.

Due to the high performance level of this model car you will need to periodically maintain and replace consumable components. Any and all warranty coverage will not cover replacement of any part or component damaged by neglect, abuse, or improper or unreasonable use. This includes but is not limited to damage from

crashing, chemical and/or water damage, excessive moisture, improper or no maintenance, or user modifications which compromise the integrity of components. Warranty will not cover components that are considered consumable on RC vehicles. XRAY does not pay nor refund shipping on any component sent to XRAY or its distributors for warranty. XRAY reserves the right to make the final determination of the warranty status of any component or part.

Limitations of Liability

XRAY makes no other warranties expressed or implied. XRAY shall not be liable for any loss, injury or damages, whether direct, indirect, special, incidental, or consequential, arising from the use, misuse, or abuse of this product and/or any product or accessory required to operate this product. In no case shall XRAY's liability exceed the monetary value of this product.

Take adequate safety precautions prior to operating this model. You are responsible for this model's assembly and safe operation.

Disregard of the any of the above cautions may lead to accidents, personal injury, or property damage. XRAY MODEL RACING CARS assumes no responsibility for any injury, damage, or misuse of this product during assembly or operation, nor any addictions that may arise from the use of this product. All rights reserved.

XRAY MODEL RACING CARS uses only the highest quality materials, the best compounds for molded parts and the most sophisticated manufacturing processes of TQM (Total Quality Management). We guarantee that all parts of a newly-purchased kit are manufactured with the highest regard to quality. However, due to the many factors inherent in model racecar competition, we cannot guarantee any

parts once you start racing the car. Products which have been worn out, abused, neglected or improperly operated will not be covered under warranty. We wish you enjoyment of this high-quality and high-performance RC car and wish you best success on the track!

In line with our policy of continuous product development, the exact specifications of the kit may vary. In the unlikely event of any problems with your new kit, you should contact the model shop where you purchased it, quoting the part number. We do reserve all rights to change any specification without prior notice. All rights reserved.

TOOLS REQUIRED



Combination Pliers (HUDY #189020)

Side Cutters (HUDY #189010)

Pocket Hobby Knife (HUDY #188981)

Cross Wrench 3mm (HUDY #107581)

Turnbuckle Wrench 3mm (HUDY #181030)

Turnbuckle Wrench 4mm (HUDY #181040)

Turnbuckle Wrench 5mm (HUDY #181050)

Special Tool for turnbuckles, nuts (HUDY #181090)

Tweezers

Scissors (HUDY #188990)

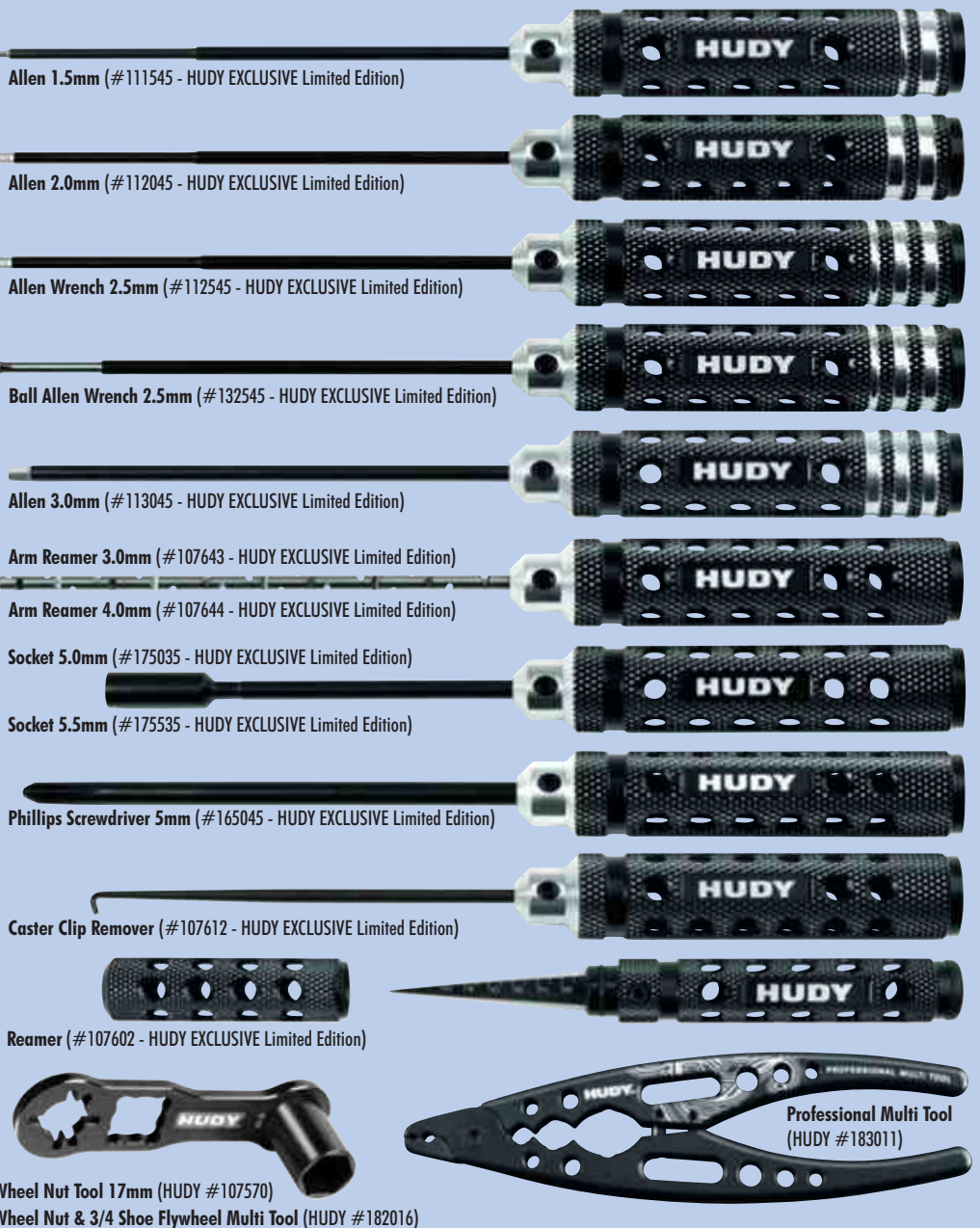

Allen 1.5mm (#111545 - HUDY EXCLUSIVE Limited Edition)

Allen 2.0mm (#112045 - HUDY EXCLUSIVE Limited Edition)

Allen Wrench 2.5mm (#112545 - HUDY EXCLUSIVE Limited Edition)

Ball Allen Wrench 2.5mm (#132545 - HUDY EXCLUSIVE Limited Edition)

Allen 3.0mm (#113045 - HUDY EXCLUSIVE Limited Edition)

Arm Reamer 3.0mm (#107643 - HUDY EXCLUSIVE Limited Edition)

Arm Reamer 4.0mm (#107644 - HUDY EXCLUSIVE Limited Edition)

Socket 5.0mm (#175035 - HUDY EXCLUSIVE Limited Edition)

Socket 5.5mm (#175535 - HUDY EXCLUSIVE Limited Edition)

Phillips Screwdriver 5mm (#165045 - HUDY EXCLUSIVE Limited Edition)

Caster Clip Remover (#107612 - HUDY EXCLUSIVE Limited Edition)

Reamer (#107602 - HUDY EXCLUSIVE Limited Edition)

Wheel Nut Tool 17mm (HUDY #107570)

Wheel Nut & 3/4 Shoe Flywheel Multi Tool (HUDY #182016)

Professional Multi Tool (HUDY #183011)

EQUIPMENT REQUIRED

<p>Transmitter & Receiver</p>	<p>Engine (FX G501 #670101)</p>	<p>Manifold & Exhaust (FX #679550)</p>	<p>Starter Box & Battery Pack (HUDY #104500)</p>	<p>Glow Plug Igniter</p>	
<p>Steering and Throttle Servos</p>	<p>Double-sided Tape (HUDY #107875)</p>	<p>Lexan™ Paint</p>	<p>Fuel + Fuel Bottle (HUDY #104200)</p>	<p>GT BODY (XRAY #359731)</p>	
<p>Battery Charger</p>	<p>Receiver Pack</p>	<p>Wheels & Tires</p>	<p>Bearing Oil (HUDY #106230)</p>	<p>Threadlock</p>	<p>CA glue</p>

EQUIPMENT INCLUDED * Kit includes smaller but sufficient amount of oil and grease to build the car.

800cSt (#106381)
HUDY Premium Silicone Oils



50.000cSt (#106551)
HUDY Premium Silicone Oils



300.000cSt (#106631)
HUDY Premium Silicone Oils



(HUDY #106210)
Premium Graphite Grease



At the beginning of each section is an exploded view of the parts to be assembled. There is also a list of all the parts and part numbers that are related to the assembly of that section. The part descriptions are color-coded to make it easier for you to identify the source of a part. Here are what the different colors mean:

STYLE A - indicates parts that are included in the bag marked for the section.
STYLE B - indicates parts that are included in the box.
STYLE C - indicates parts that are already assembled from previous steps.

GTX TECH TIPS

TIP FRONT & REAR DIFF GEAR MESH ADJUSTMENT

If there is too much or too little diff side play, this may create non-optimal gear mesh between the diff gear and the pinion drive gear. This is easily resolved by inserting 1 or 2 of the included thin shims behind a diff outdrive ball-bearing, depending on how much play there is.

THE LOCATION OF THE SHIM(S) DEPENDS ON WHETHER YOU ARE TRYING TO CLOSE OR OPEN THE GAP:

TO CLOSE A WIDE GAP

CLOSE A WIDE GAP

To CLOSE a wide gap: add 1 or 2 shims against diff spur gear

insert shim(s) here

WASHER #962131 S 13 x 16 x 0.1 mm (10)
#962130 S 13 x 16 x 0.2 mm (10)

TO OPEN A NARROW GAP

OPEN A NARROW GAP

To OPEN a narrow gap: add 1 or 2 shims on the other side of the diff, away from spur gear

insert shim(s) here

WASHER #962131 S 13x16x0.1mm (10)
#962130 S 13x16x0.2mm (10)

CHECK GEAR MESH AND DIFF PLAY ONLY AFTER THE ENTIRE GEARBOX IS MOUNTED TOGETHER WITH THE SUSPENSION HOLDERS ON THE CHASSIS. ALL PARTS ARE DESIGNED TO HAVE CERTAIN PLAY AND IT IS ALL DESIGNED BY PURPOSE.

SUSPENSION & DRIVETRAIN MAINTENANCE

- Check suspension for free movement during building and operation, and especially after running and if you have crashed the car. If the suspension does not move freely, use the appropriate HUDY Arm Reamer to clean and resize the holes of the suspension arms.
- Regularly check the drive shaft pins (both side and center) and if they show any wear must be immediately replaced by new pins. If the car is run with worn pins, excessive wear on the diff outdrives will result. The 106000 HUDY Drive Pin Replacement Tool (for 3mm Pins) is a compact, rugged multi-use tool set for replacing 3mm drive pins in drive shafts. Use the HUDY replacement drive shaft pins 3x14 (#106050).
- Regularly inspect and replace the connecting pins which connect the center drive shafts with the pinion gear, and also the pins that connect the wheel drive shafts with wheel axles. Use HUDY Graphite Grease to lubricate the drive shaft connecting joints and the diff gears.
- Pivot balls and ball-joints will naturally wear for some time and will generate play. If there is too much play the pivot balls and ball joints need to be replaced.
- If the car is run in wet conditions, apply WD-40® on all drivetrain parts before the run. After the run, clean and dry the parts again.

HUDY SPRING STEEL™

The HUDY Spring Steel™ used in the car is the strongest and most durable steel material on the RC market. While items made from HUDY Spring Steel™ are still subject to wear, the lifespan is considerably longer than any other material. As parts made from HUDY Spring Steel™ wear, the brown color will after some time "go down" but it will not affect the strength of the material. The brown color is only a surface treatment and if the brown color will wear the durability of the part will be still strong.

TIP DRIVE SHAFT PIN SERVICING

To enjoy the longest possible lifespan of the drive shafts and diff outdrives, it is extremely important to properly service the drive shaft pins. Inspect the pins after every 3 hours of runtime. If the pins show any wear, replace them with new pins.

1 Do not use drive shafts when the pins are worn.

2 Press out the worn pins.

3 Press in new pins and regularly inspect for wear.

For easy drive pin replacements use #106000 HUDY Drive Pin Replacement Tool.

To replace the worn pins use only premium HUDY drive pins #106050.

1. DIFFERENTIALS



XRAY BALL-BEARING

OPTION	#930816	8x16x5	GREASE	STEEL	OPTION
	#930817	8x16x5	OIL	STEEL	OPTION
	#940816	8x16x5	GREASE	RUBBER	OPTION
	#940817	8x16x5	OIL	RUBBER	INCLUDED



355064
FRONT DIFF. OUTDRIVE ADAPTER
LONG - V2 - HSS™ (2)

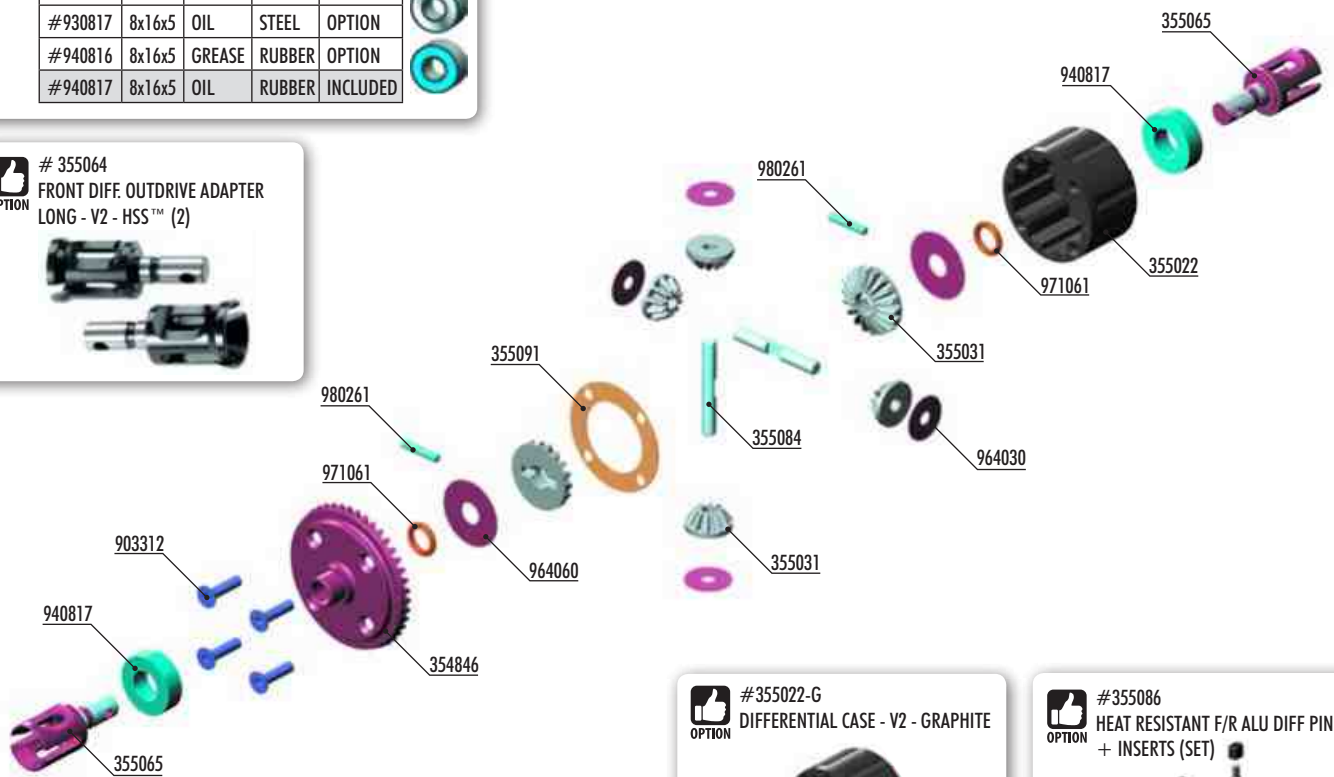

#355022-G
DIFFERENTIAL CASE - V2 - GRAPHITE



#355086
HEAT RESISTANT F/R ALU DIFF PIN
+ INSERTS (SET)



- 354846 FR/RE DIFF LARGE BEVEL GEAR 46T - FOR 13T PINION GEAR
- 355006 DIFFERENTIAL 46T - MATCHED FOR 13T PINION GEAR - SET
- 355022 DIFFERENTIAL CASE - V2
- 355031 STEEL DIFF BEVEL & SATELLITE GEARS - V2 (2+4)
- 355065 DIFF OUTDRIVE ADAPTER - V2 - HUDY SPRING STEEL™ (2)
- 355084 F/R DIFF PIN (2)
- 355091 F/R DIFF GASKET (4)

- 903312 HEX SCREW SFH M3x12 (10)
- 940817 BALL-BEARING 8x16x5 RUBBER SEALED - OIL (2)
- 964030 WASHER S 3.5x12x0.2 (10)
- 964060 WASHER S 6x18x0.2 (10)
- 971061 SILICONE O-RING 6x1.55 (10)
- 980261 PIN 2.5x11.5 (10)

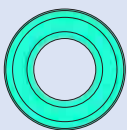

940817
BB 8x16x5



964060
S 6x18x0.2



971061
O 6x1.55



980212
P 2x11.6

2x
F=R

TIP Use HUDY Ball-Bearing Grease or Oil for servicing:
#106220 - Standard
#106221 - Extra
#106222 - Premium
#106230 - Bearing Oil

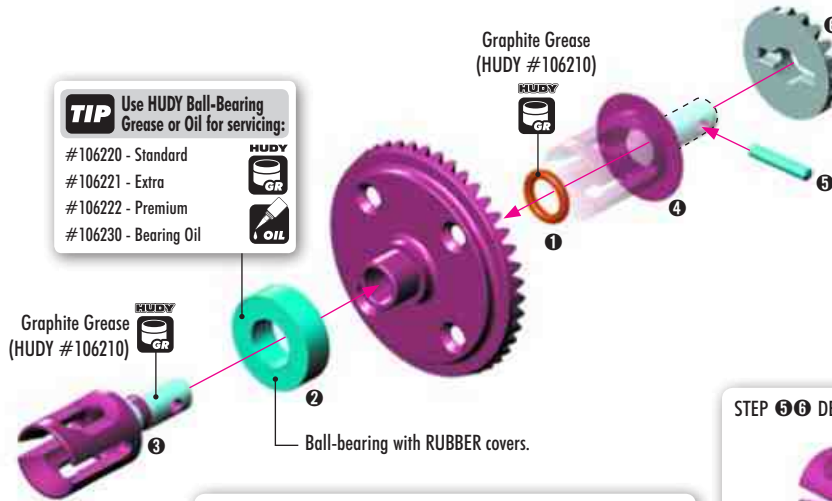

XRAY BALL-BEARING

OPTION	#930816	8x16x5	GREASE	STEEL	OPTION
	#930817	8x16x5	OIL	STEEL	OPTION
	#940816	8x16x5	GREASE	RUBBER	OPTION
	#940817	8x16x5	OIL	RUBBER	INCLUDED



STEP 5-6 DETAIL

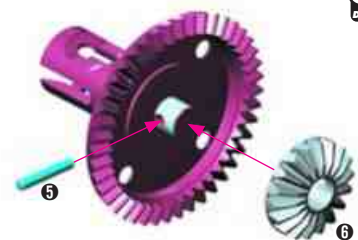

SET-UP BOOK
DIFFERENTIAL GEARS

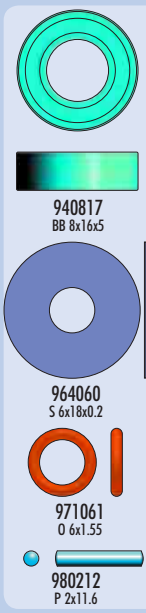

2x

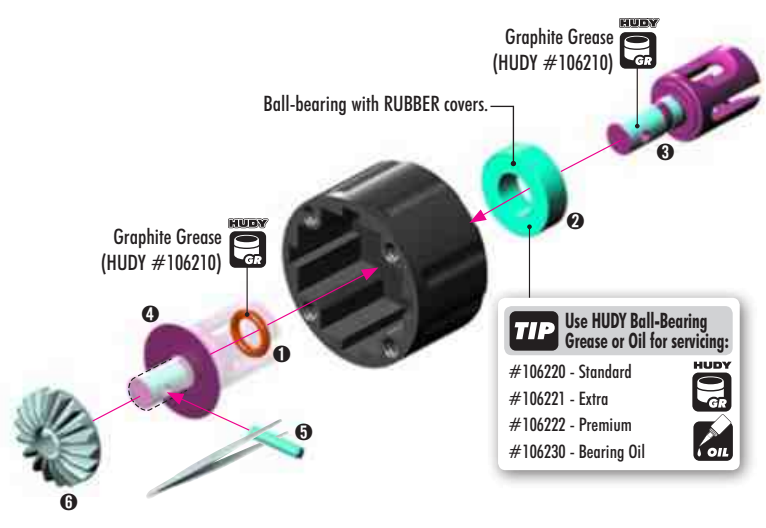

TIP Use HUDY Ball-Bearing Grease or Oil for servicing:

- #106220 - Standard
- #106221 - Extra
- #106222 - Premium
- #106230 - Bearing Oil



VERY IMPORTANT!

Use the following silicone oils included in the kit for initial settings:
 FRONT diff: 300.000cSt / REAR diff: 50.000cSt

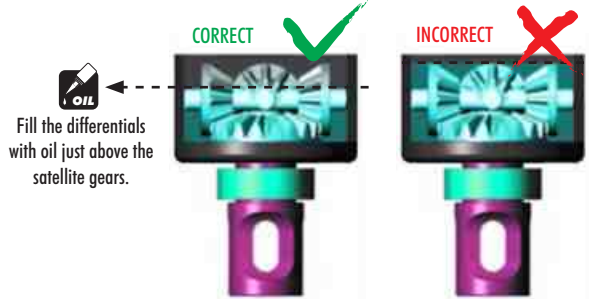

IMPORTANT!
 Do not overfill the differential. If there is too much oil in the differential, it may leak after it cools down after use.

To ensure you have the same amount of oil from rebuild to rebuild, do the following:

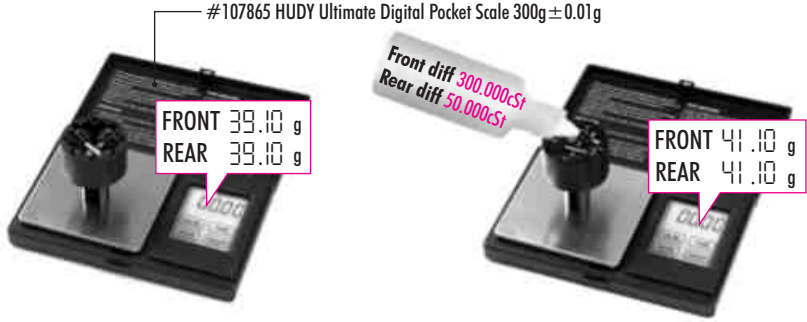

- Put the diff (without oil) on the scale and check the weight:
 - FRONT DIFF approx. 39.10g
 - REAR DIFF approx. 39.10g
- Slowly pour oil into the diff and watch the weight. The approximate weight of the diff+oil is REAR DIFF approx. 41.10g and FRONT DIFF approx. 41.10g

REAR DIFF	39.10g + 2.0g	= 41.10g
FRONT DIFF	39.10g + 2.0g	= 41.10g

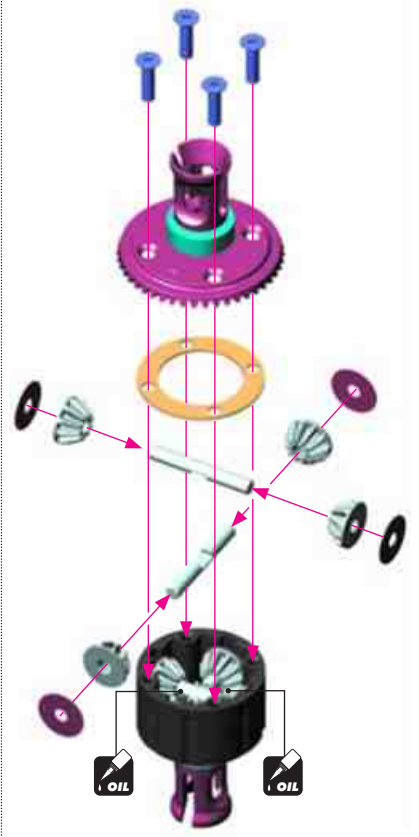

Front diff:
 Silicone oil 300.000cSt
 Fill just above the satellite gears.

Rear diff:
 Silicone oil 50.000cSt
 Fill just above the satellite gears.

SET-UP BOOK
 DIFFERENTIAL OIL

Tighten the screws equally.



Finish tightening in this order.



After assembly the differentials should have a length of 32.3~32.5 mm measured from the ends of the installed ball-bearings. If differentials are longer, retighten the 4 screws holding the crown gears.

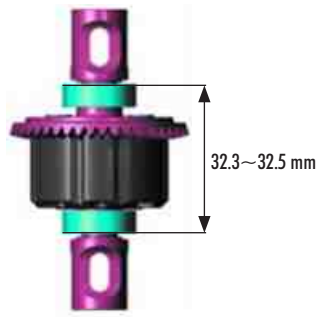

2. FRONT & REAR TRANSMISSION



XRAY BALL-BEARING

OPTION	#	SIZE	LUBRICATION	MATERIAL	STATUS
	#930816	8x16x5	GREASE	STEEL	INCLUDED
	#930817	8x16x5	OIL	STEEL	OPTION

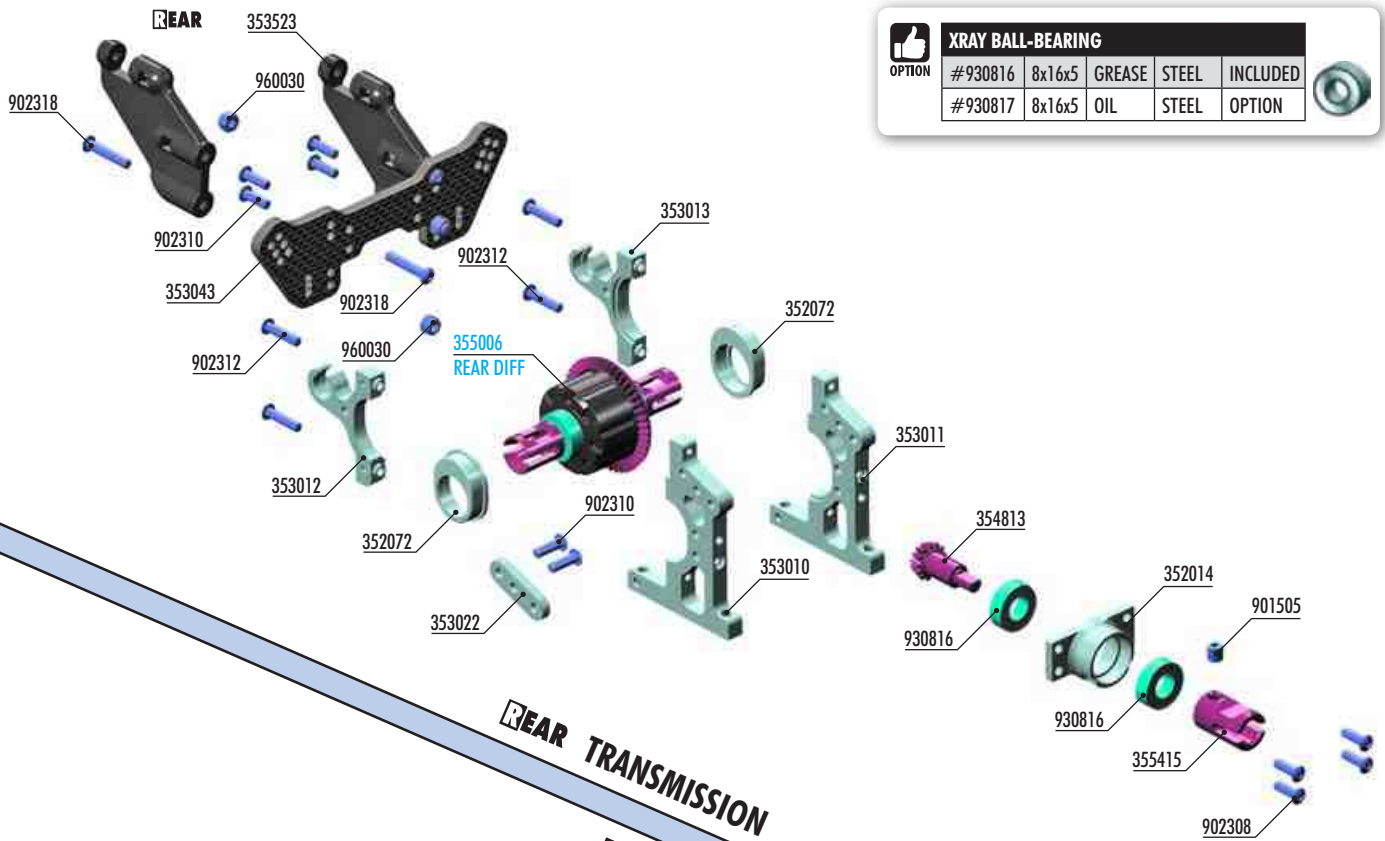

REAR TRANSMISSION

FRONT TRANSMISSION

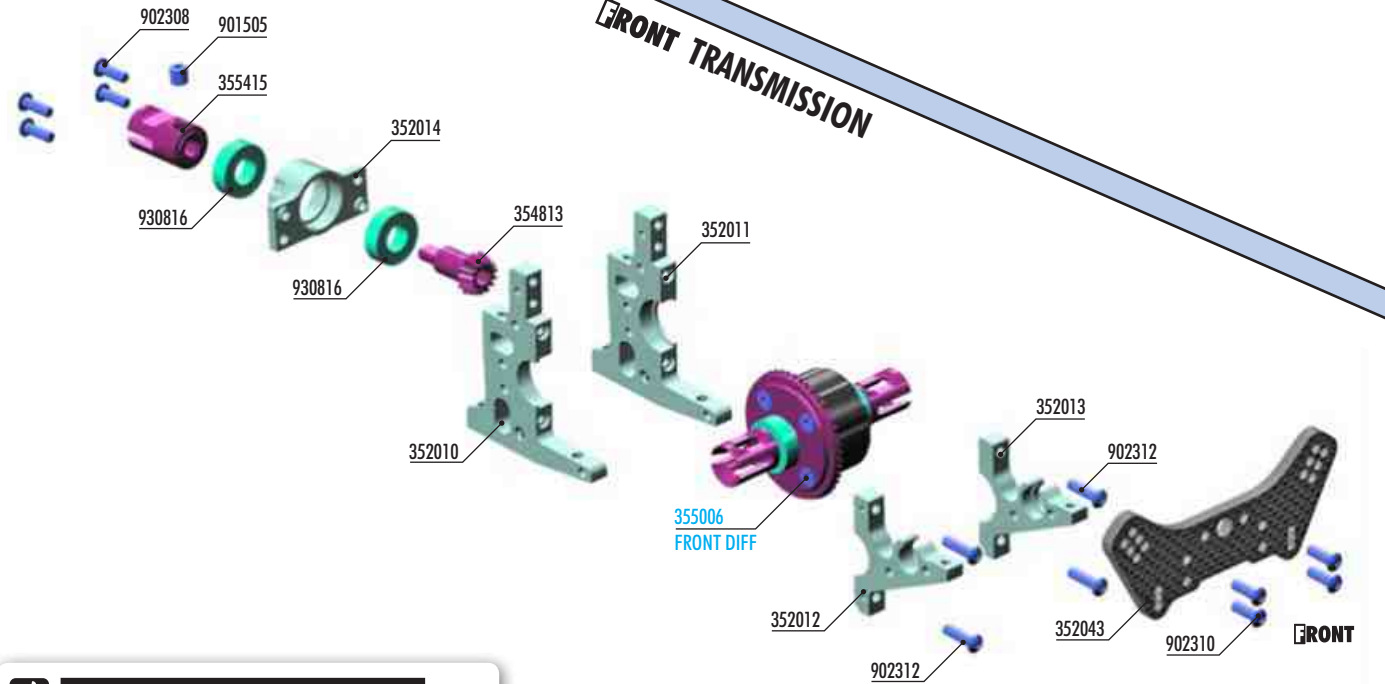

XRAY BALL-BEARING

OPTION	#	SIZE	LUBRICATION	MATERIAL	STATUS
	#930816	8x16x5	GREASE	STEEL	INCLUDED
	#930817	8x16x5	OIL	STEEL	OPTION



BAG

02

- 352010 ALU FRONT BULKHEAD - RIGHT - SWISS 7075 T6
- 352011 ALU FRONT BULKHEAD - LEFT - SWISS 7075 T6
- 352012 ALU FRONT ANTI-ROLL BAR BULKHEAD - RIGHT - SWISS 7075 T6
- 352013 ALU FRONT ANTI-ROLL BAR BULKHEAD - LEFT - SWISS 7075 T6
- 352014 GT ALU ADAPTER FOR CENTER JOINT - SWISS 7075 T6
- 352043 GRAPHITE FRONT SHOCK TOWER 4MM
- 352072 ALU ADJUSTMENT BALL-BEARING HUB - SWISS 7075 T6 (2)
- 353010 ALU REAR BULKHEAD - RIGHT - SWISS 7075 T6
- 353011 ALU REAR BULKHEAD - LEFT - SWISS 7075 T6
- 353012 ALU REAR ANTI-ROLL BAR BULKHEAD - RIGHT - SWISS 7075 T6
- 353013 ALU REAR ANTI-ROLL BAR BULKHEAD - LEFT - SWISS 7075 T6
- 353022 ALU REAR BRACE HOLDER - SWISS 7075 T6
- 353043 GRAPHITE REAR SHOCK TOWER 4MM

- 353523 GT COMPOSITE REAR HOLDER POST (2)
- 354813 BEVEL DRIVE PINION GEAR 13T - MATCHED FOR 46T LARGE BEVEL GEAR
- 355415 CENTRAL DOGBONE SHAFT UNIVERSAL JOINT - HUDY SPRING STEEL™ (2)
- 901505 HEX SCREW SB M5x5 (10)
- 902308 HEX SCREW SH M3x8 (10)
- 902310 HEX SCREW SH M3x10 (10)
- 902312 HEX SCREW SH M3x12 (10)
- 902318 HEX SCREW SH M3x18 (10)
- 930816 BALL-BEARING 8x16x5 STEEL SEALED - GREASE (2)
- 960030 NUT M3 (10)
- 355006 DIFFERENTIAL 46T - MATCHED FOR 13T PINION GEAR - SET

2. FRONT & REAR TRANSMISSION

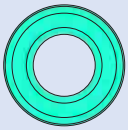

930816
BB 8x16x5



901505
SB M5x5

2x FRONT & REAR TRANSMISSION

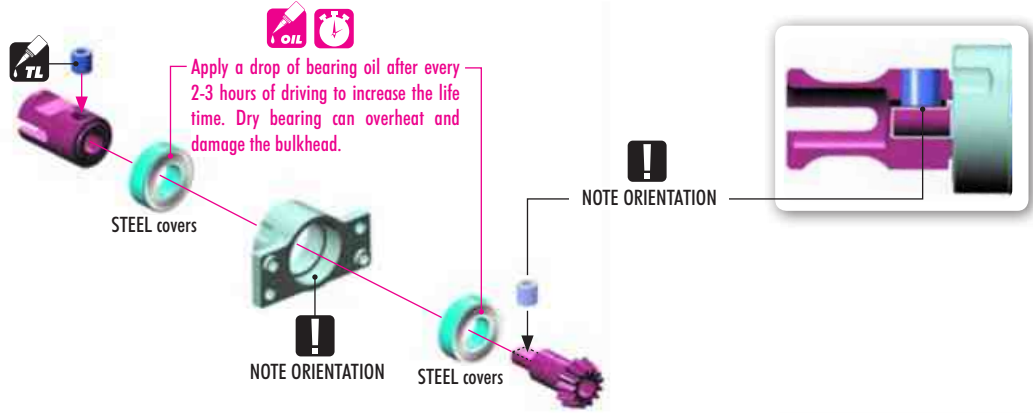

TIP Use HUDY Ball-Bearing Grease or Oil for servicing:

HUDY

- #106220 - Standard
- #106221 - Extra
- #106222 - Premium
- #106230 - Bearing Oil

XRAY BALL-BEARING

OPTION	#930816	8x16x5	GREASE	STEEL	INCLUDED
	#930817	8x16x5	OIL	STEEL	OPTION



902308
SH M3x8

REAR TRANSMISSION

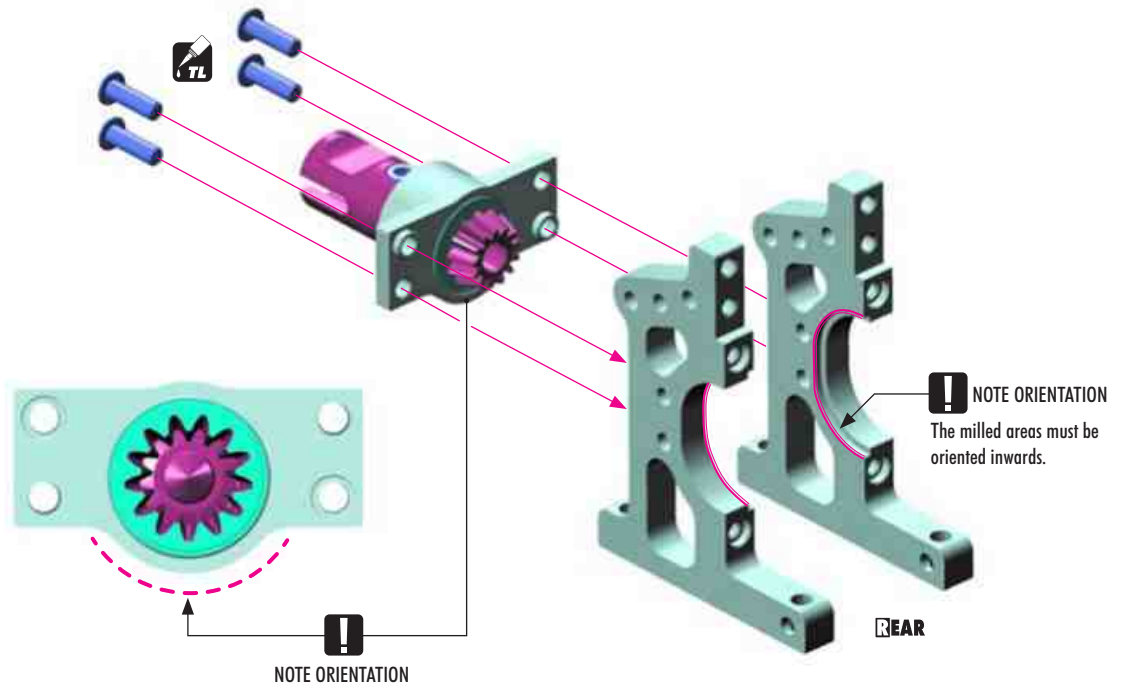

2. FRONT & REAR TRANSMISSION



902312
SH M3x12

REAR TRANSMISSION

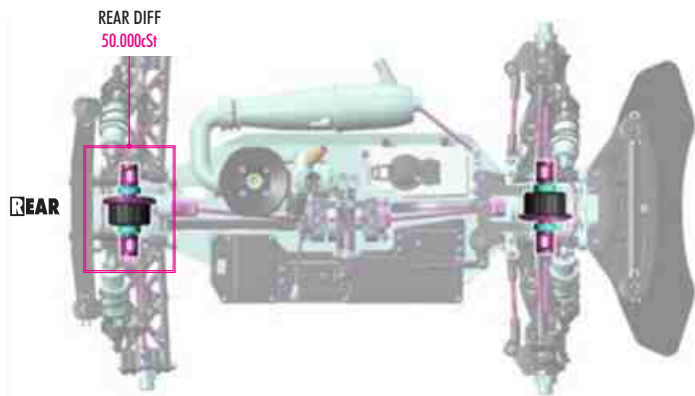
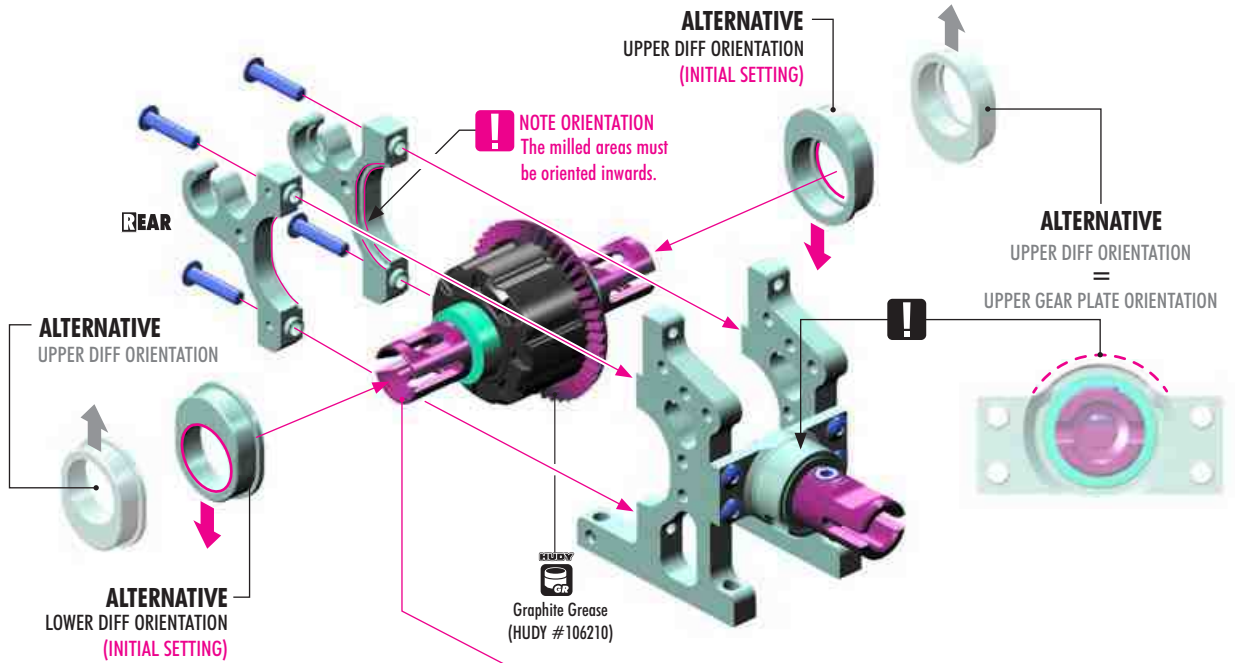

902310
SH M3x10



902318
SH M3x18



960030
N M3

2x

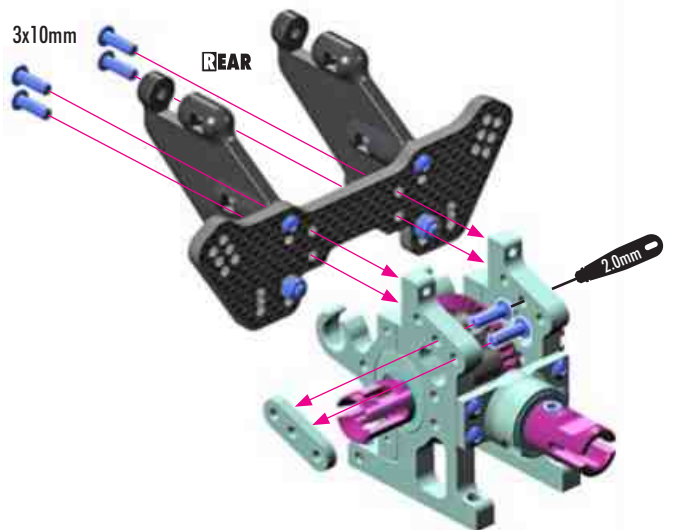
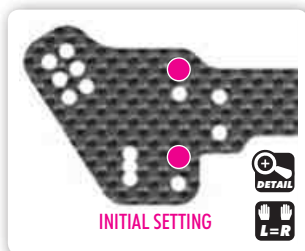
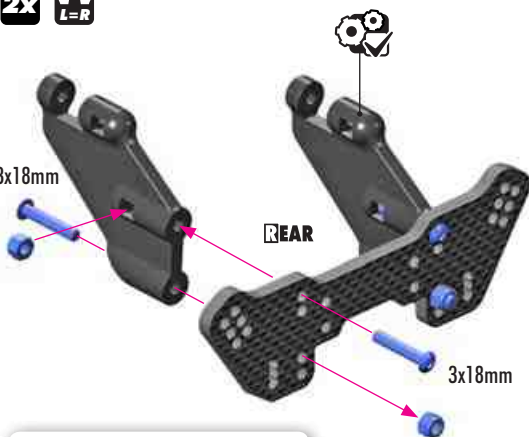

2. FRONT & REAR TRANSMISSION

FRONT TRANSMISSION



902308
SH M3x8

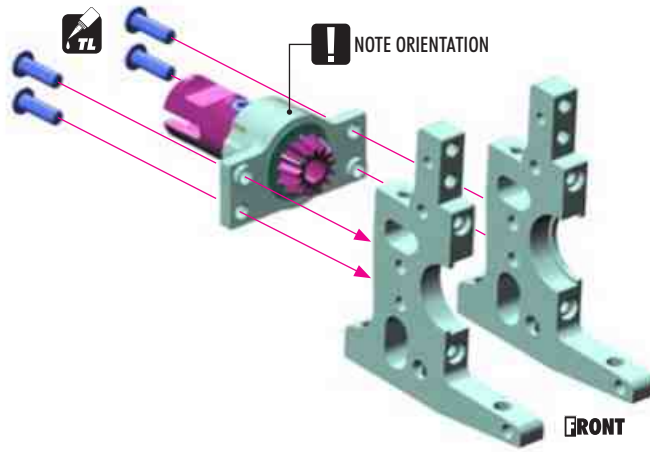

FRONT TRANSMISSION



902312
SH M3x12

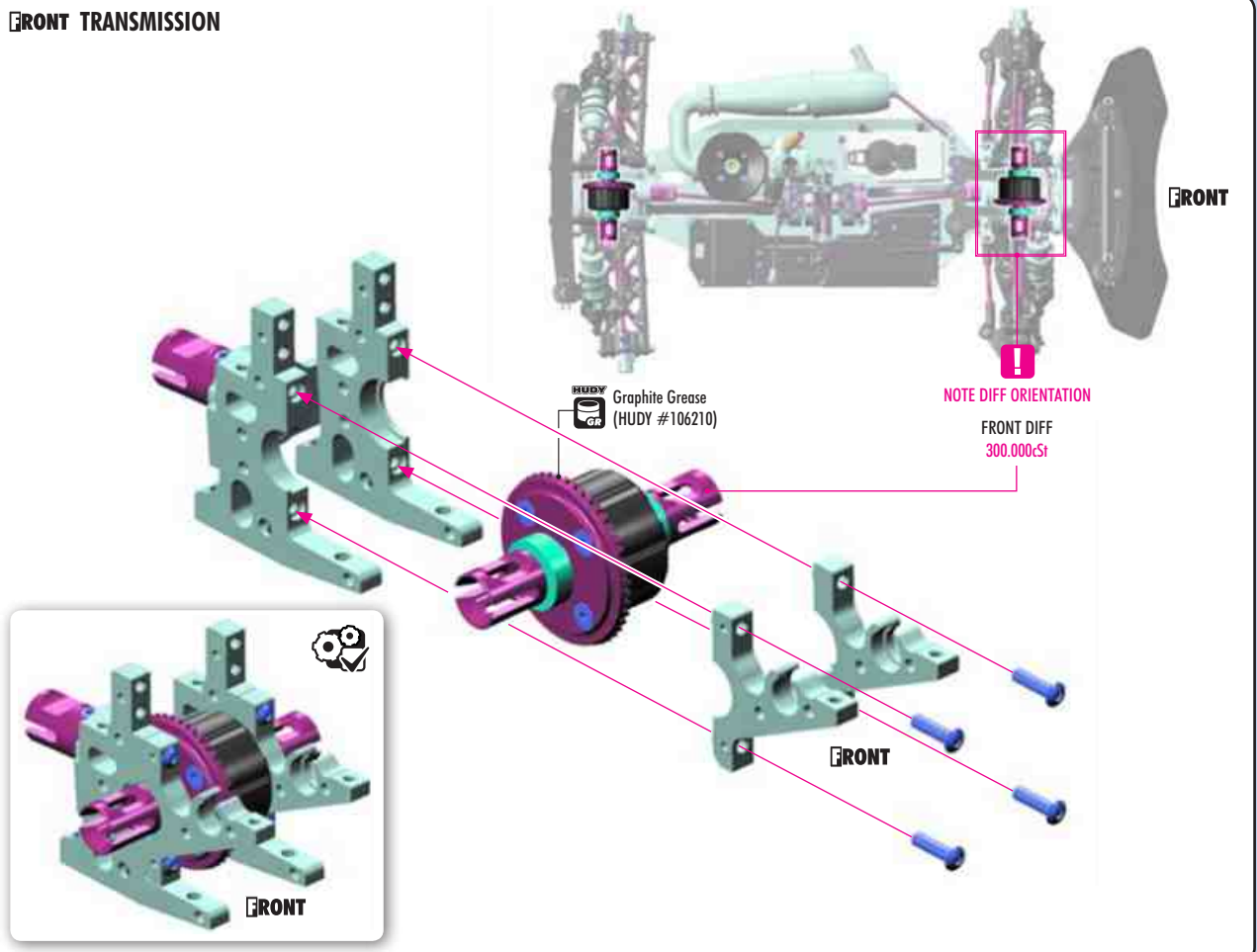

902310
SH M3x10

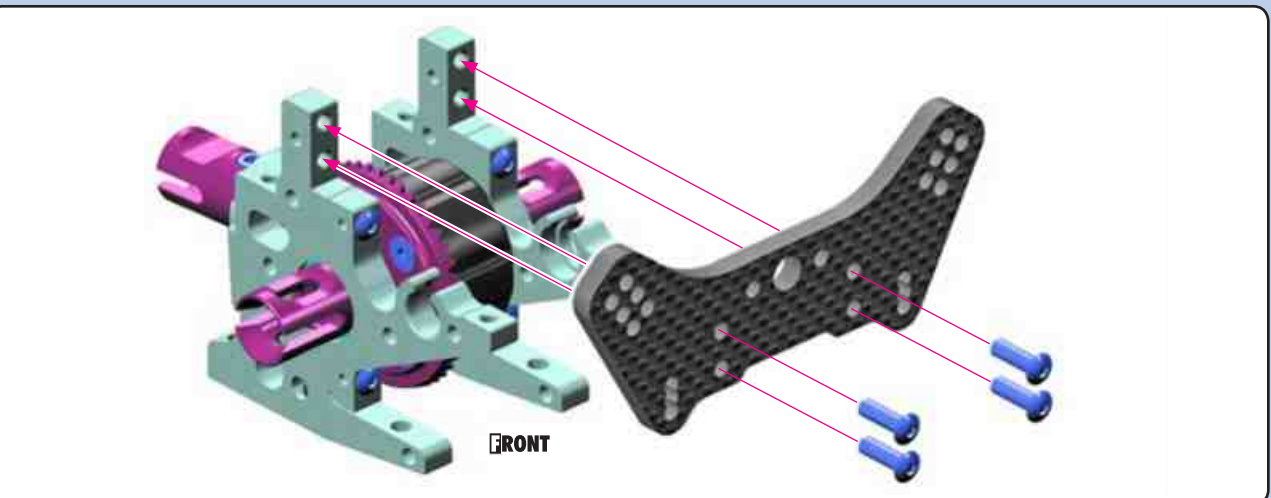

3. REAR SUSPENSION

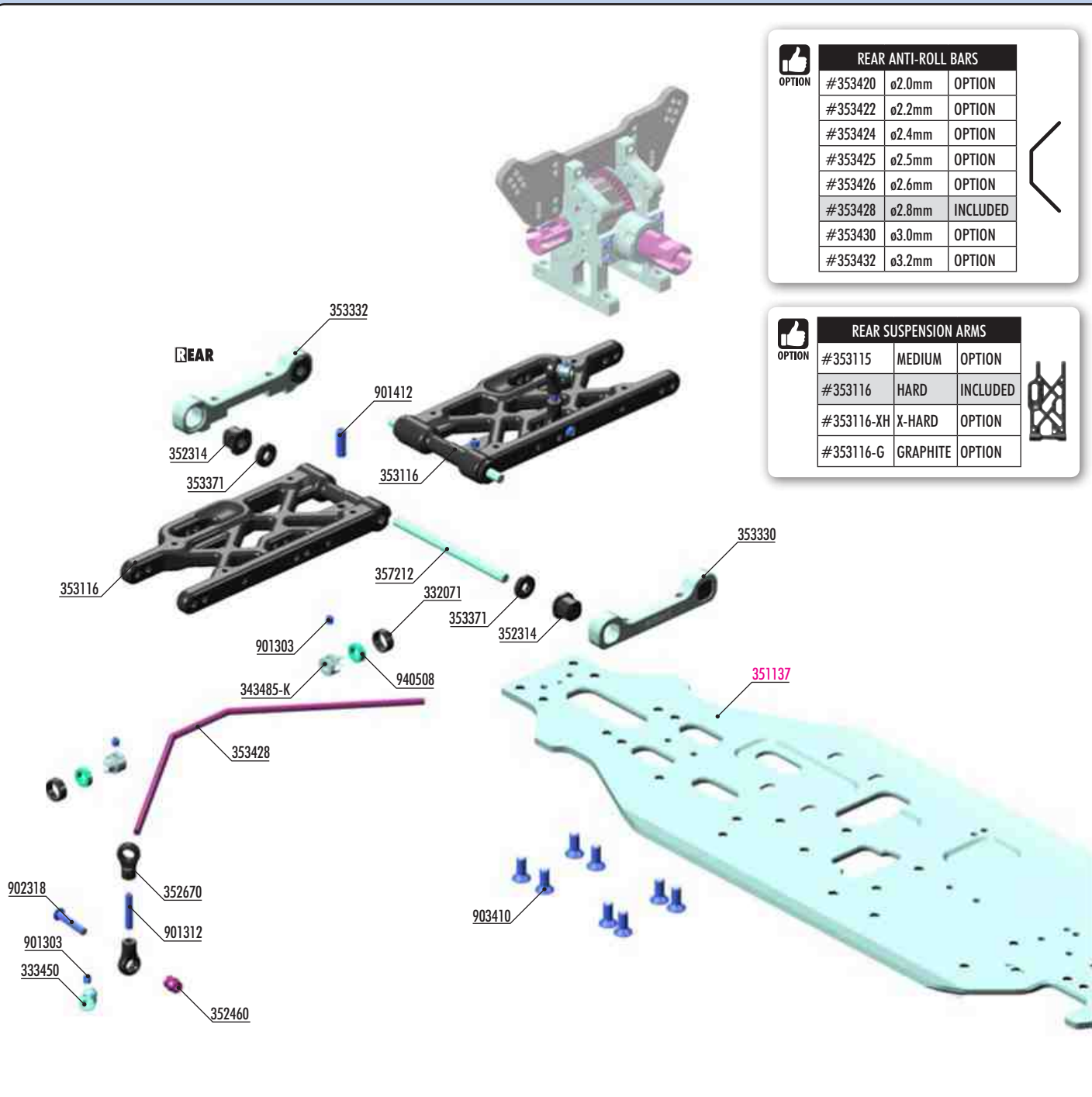

REAR ANTI-ROLL BARS			
OPTION	#353420	ø2.0mm	OPTION
	#353422	ø2.2mm	OPTION
	#353424	ø2.4mm	OPTION
	#353425	ø2.5mm	OPTION
	#353426	ø2.6mm	OPTION
	#353428	ø2.8mm	INCLUDED
	#353430	ø3.0mm	OPTION
	#353432	ø3.2mm	OPTION

REAR SUSPENSION ARMS			
OPTION	#353115	MEDIUM	OPTION
	#353116	HARD	INCLUDED
	#353116-XH	X-HARD	OPTION
	#353116-G	GRAPHITE	OPTION

ALU ANTI-ROLL BAR COLLAR			
OPTION	#343483-K	ø2.2mm	OPTION
	#343484-K	ø2.4mm	OPTION
	#343482-K	ø2.6mm	OPTION
	#343485-K	ø2.8mm	INCLUDED
	#343481-K	ø3.0mm	OPTION

OPTION	#333451	ALU ANTI-ROLL BAR PIVOT BALL 5.8 MM - SWISS 7075 T6 - HARDCOATED (2)
---------------	---------	---

BAG
03

- | | | | |
|----------|---|---------------|---|
| 332071 | COMPOSITE BALL-BEARING HUB (4) | 901303 | HEX SCREW SB M3x3 (10) |
| 333450 | ANTI-ROLL BAR BALL JOINT 5.8 MM (2) | 901312 | HEX SCREW SB M3x12 (10) |
| 343485-K | ALU CUTTED ANTI-ROLL BAR COLLAR ø2.8 - BLACK (2) | 901412 | HEX SCREW SB M4x12 (10) |
| 352314 | COMPOSITE ECCENTRIC BUSHINGS - V2 (2) | 902318 | HEX SCREW SH M3x18 (10) |
| 352460 | PIVOT BALL 5.8 (10) | 903410 | HEX SCREW SFH M4x10 (10) |
| 352670 | COMPOSITE BALL JOINT 5.8 (8) | 940508 | BALL-BEARING 5x8x2.5 RUBBER SEALED - OIL (2) |
| 353116 | COMPOSITE REAR LOWER SUSPENSION ARM - HARD | 351137 | GTX'23 ALU CHASSIS - SWISS 7075 T6 (3MM) |
| 353330 | ALU REAR LOWER SUSP. HOLDER - FRONT - SQUARE ADJ. ROLL-C. | | |
| 353332 | ALU REAR LOWER SUSP. HOLDER - REAR - SQUARE ADJ. ROLL-C. | | |
| 353371 | SET OF COMPOSITE LOWER ARM SHIMS | | |
| 353428 | REAR ANTI-ROLL BAR 2.8MM | | |
| 357212 | LOWER INNER PIVOT PIN F+R (2) | | |

3. REAR SUSPENSION



353371
SHIM 4x10x2



901412
SB M4x12

TOP DOWNSTOP SETTING

DETAIL

L=R

BOTTOM 3.4mm

REAR

RR

2mm

RR

1° 0.5°

INITIAL SETTING

! NOTE ARMS ORIENTATION

2mm

RF

RF

1° 0.5°

INITIAL SETTING

TIP

If the suspension arm does not move freely use a HUDY Arm Reamer to resize the holes of the arms.

(HUDY #107634)

ARM REAMER

REAR SUSPENSION ARMS			
OPTION			
#353115	MEDIUM	OPTION	
#353116	HARD	INCLUDED	
#353116-XH	X-HARD	OPTION	
#353116-G	GRAPHITE	OPTION	

ANTI-SQUAT		
RR	RF	(°)
□	□	= 1°
□	□	= 2°
□	□	= 0°
□	□	= 2°
□	□	= 1°
□	□	= 3°
□	□	= 0°
□	□	= 1°
□	□	= -1°

The new XRAY rear alu lower suspension holders provide even greater range of adjustment for the rear suspension. Using different combinations of eccentric bushings, fine adjustment of rear anti-squat, rear toe-in, rear roll center, and rear track-width can be obtained. For more information about the influence of rear anti-squat, rear toe-in, rear roll center and rear track width on car handling, please refer to HUDY Off-Road Set-up Book (#209099).

ROLL CENTER		
RR	RF	(mm)
□	□	= 0mm
□	□	= 1mm
□	□	= -1mm

TRACK-WIDTH		
RR	RF	(mm)
□	□	= 308
□	□	= 306
□	□	= 310

The tables describe the amounts of rear anti-squat, rear toe-in, rear track-width change depending on the combinations of eccentric bushings used with 0 and 1mm, 1° off set. The 0.5mm, 0.5° represent the half change.

TOE-IN		
RR	RF	(°)
□	□	= 3°
□	□	= 4°
□	□	= 2°
□	□	= 2°
□	□	= 3°
□	□	= 1°
□	□	= 4°
□	□	= 5°
□	□	= 3°



903410
SFH M4x10

REAR

Push the arm from both sides to create play.

DETAIL

3. REAR SUSPENSION



903410
SFH M4x10

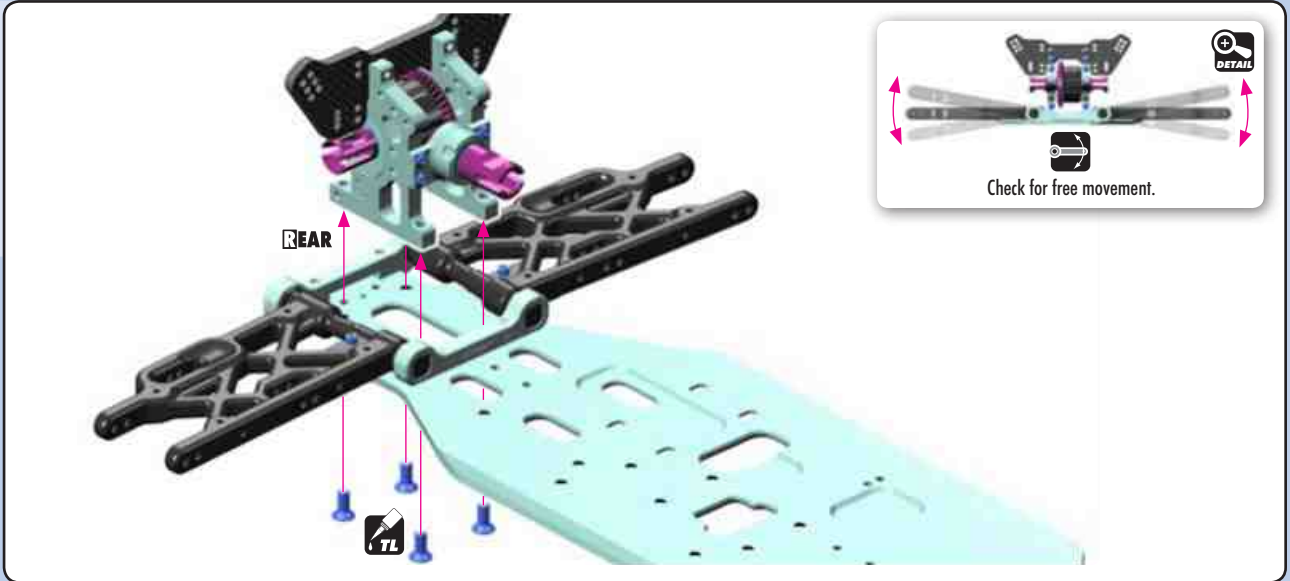

901312
SB M3x12



940508
BB 5x8x2.5

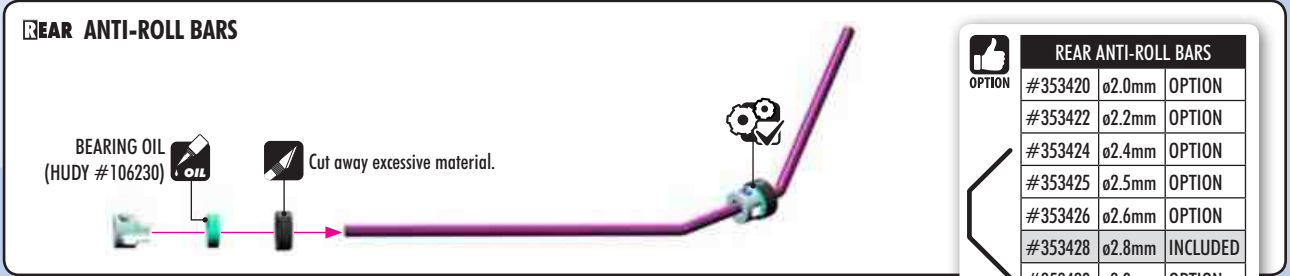

901303
SB M3x3

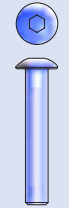

902318
SH M3x18

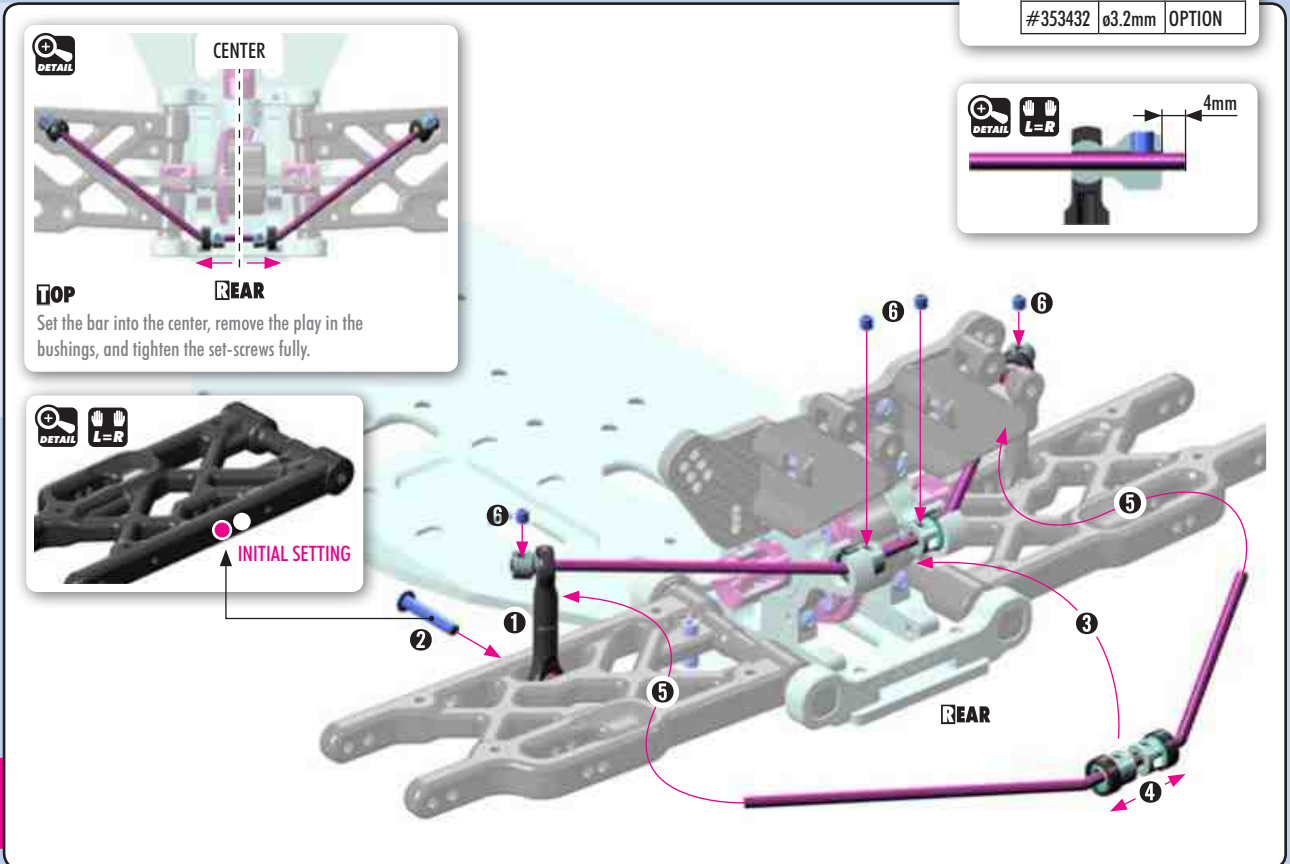

4. REAR SUSPENSION

2x

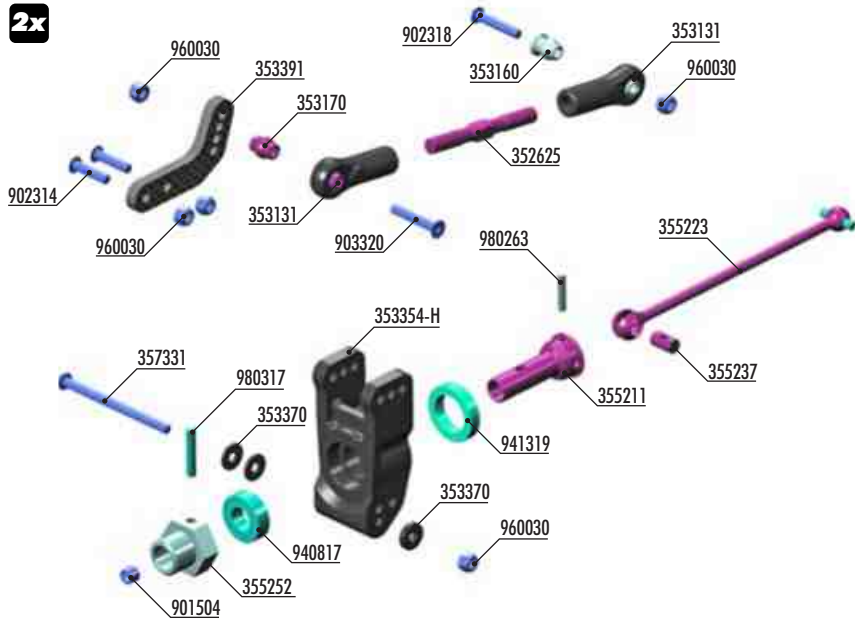

OFFSET WHEEL AXLES

#355250	0mm	OPTION
#355251	+ 1mm	OPTION
#355252	+ 2mm	INCLUDED



REAR UPRIGHTS

#353354	MEDIUM	OPTION
#353354-H	HARD	INCLUDED
#353354-G	GRAPHITE	OPTION



#350909 XRAY GTX ALU REAR UPRIGHTS - SET

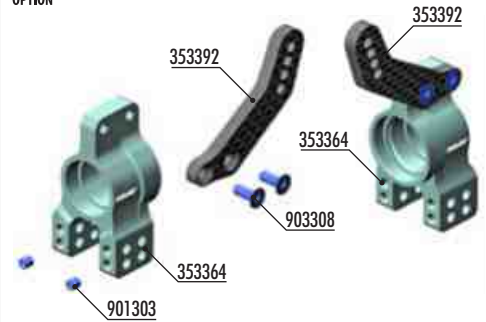

XRAY BALL-BEARING

#930816	8x16x5	GREASE	STEEL	OPTION
#940816	8x16x5	GREASE	RUBBER	OPTION
#931318	13x19x4	GREASE	STEEL	OPTION
#941318	13x19x4	GREASE	RUBBER	OPTION
#930817	8x16x5	OIL	STEEL	OPTION
#940817	8x16x5	OIL	RUBBER	INCLUDED
#931319	13x19x4	OIL	STEEL	OPTION
#941319	13x19x4	OIL	RUBBER	INCLUDED



BAG

04

- 352625 ADJ. TURNBUCKLE M5 L/R 46MM - HUDY SPRING STEEL™ (2)
- 353131 REAR UPPER INNER CAMBER LINK BALL JOINT - V3 (2)
- 353160 MOUNTING BALL 6.8 (4)
- 353170 PIVOT BALL 6.8 (4)
- 353354-H COMPOSITE REAR UPRIGHT LB - HARD
- 353370 SET OF COMPOSITE REAR HUB CARRIER SHIMS
- 353391 GRAPHITE REAR ROLL CENTER UPRIGHT PLATE 4MM - V2 (2)
- 355211 CVD DRIVE AXLE - HUDY SPRING STEEL™
- 355223 CVD UNIVERSAL DRIVE SHAFT 93MM - HUDY SPRING STEEL™
- 355237 CVD DRIVE SHAFT COUPLING - HUDY SPRING STEEL™
- 355252 ALU WHEEL AXLE OFFSET +2MM - BLACK COATED (2)
- 357331 REAR LOWER OUTER PIVOT PIN SCREW 3MM (2)

- 901504 HEX SCREW SB M5x4 (10)
- 902314 HEX SCREW SH M3x14 (10)
- 902318 HEX SCREW SH M3x18 (10)
- 903320 HEX SCREW SFH M3x20 (10)
- 940817 BALL-BEARING 8x16x5 RUBBER SEALED - OIL (2)
- 941319 BALL-BEARING 13x19x4 RUBBER SEALED - OIL (2)
- 960030 NUT M3 (10)
- 980263 PIN 2.5x13 (10)
- 980317 PIN 3x17 (10)



941319
BB 13x19x4



940817
BB 8x16x5

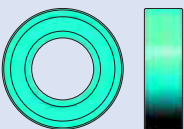

980263
P 2.5x13

980317
P 3x17



901504
SB M5x4

2x

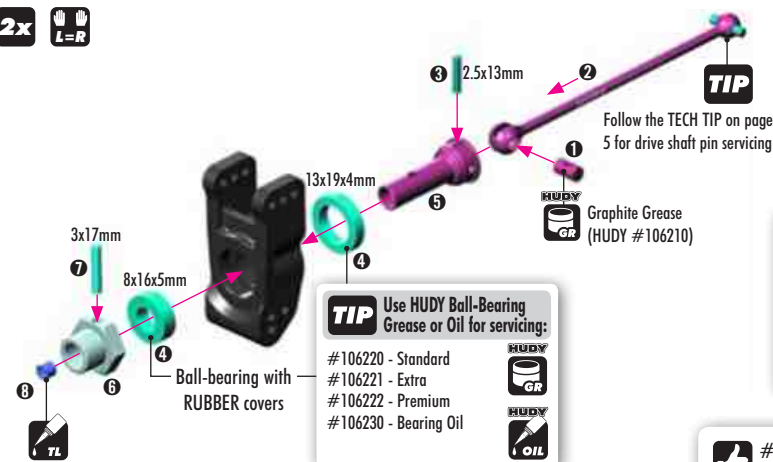

TIP

Follow the TECH TIP on page 5 for drive shaft pin servicing

TIP

Use HUDY Ball-Bearing Grease or Oil for servicing:

- #106220 - Standard
- #106221 - Extra
- #106222 - Premium
- #106230 - Bearing Oil



TIP

To tighten the setscrew you can also use the HUDY 17mm Wheel Nut Tool #107570.



OFFSET WHEEL AXLES

#355250	0mm	OPTION
#355251	+ 1mm	OPTION
#355252	+ 2mm	INCLUDED



REAR UPRIGHTS

#353354	MEDIUM	OPTION
#353354-H	HARD	INCLUDED
#353354-G	GRAPHITE	OPTION
#353364	ALU	OPTION



#350909 XRAY GTX ALU REAR UPRIGHTS - SET



4. REAR SUSPENSION



353370
SHIM 3x9x1



353370
SHIM 3x9x2



960030
N M3

2x L=R

TIP Ensure that the rear upright moves freely. If it does not move freely, use sandpaper to thin both wheelbase adjustment shims.

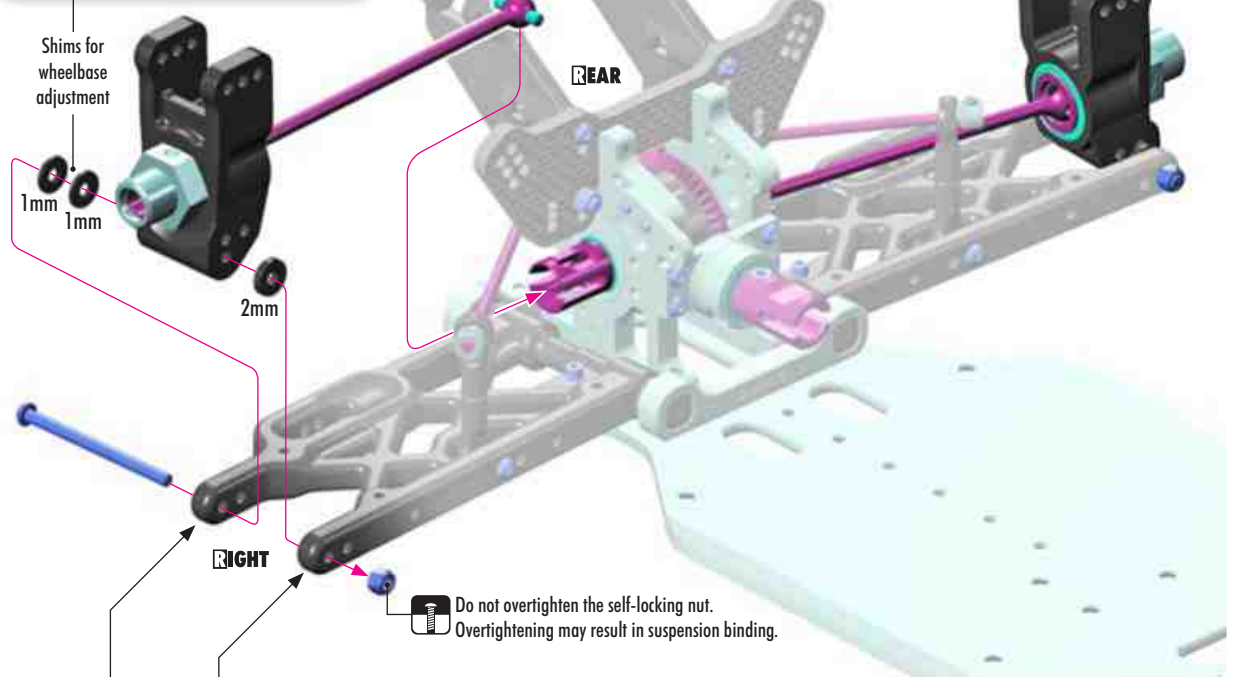

TIP L=R

If the suspension arm does not move freely use a HUDY Arm Reamer to resize the holes of the arms. (HUDY #107633)

DETAIL

INITIAL SETTING

DETAIL Check for free movement.

2x L=R

TIP

Install the pivot balls with Professional Multi Tool (HUDY #183011).

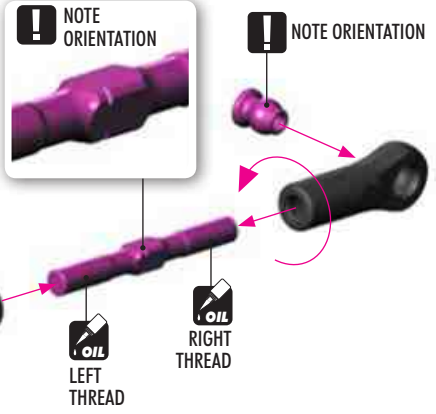

Use tools to tighten as shown. **DETAIL**

Special Tool for all turnbuckles & nuts (HUDY #181090) or Turnbuckle Wrench 5mm (HUDY #181050).

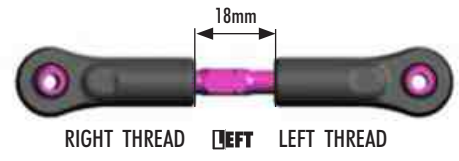
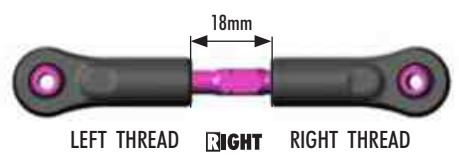

SET-UP BOOK
CAMBER

4. REAR SUSPENSION

- 

902314
SH M3x14
- 

902318
SH M3x18
- 

903320
SFH M3x20
- 

960030
N M3

2x 

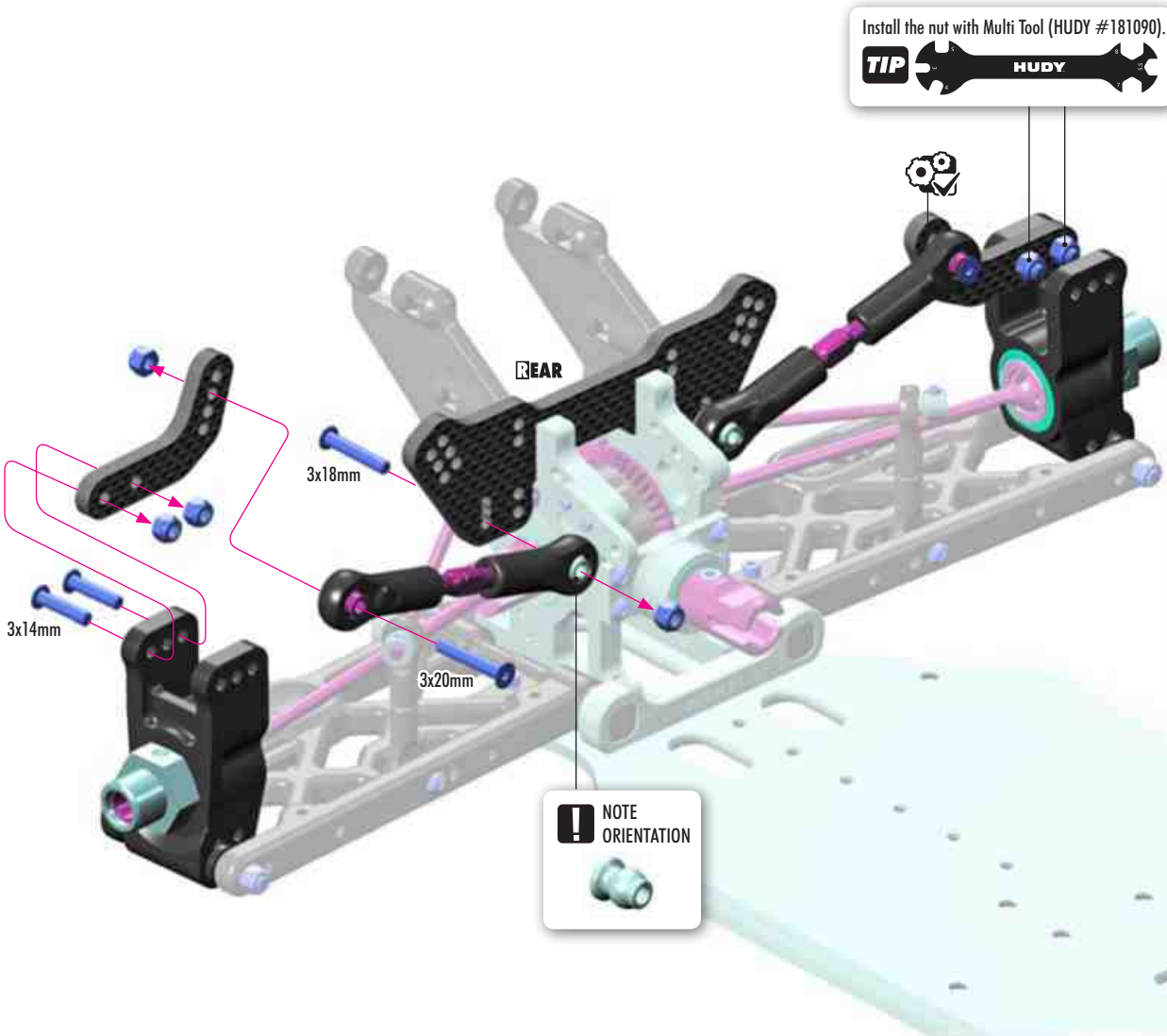

Install the nut with Multi Tool (HUDY #181090).
TIP 

! NOTE ORIENTATION

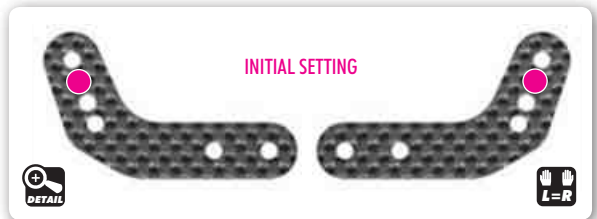
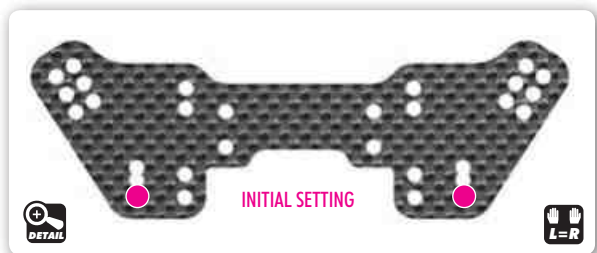
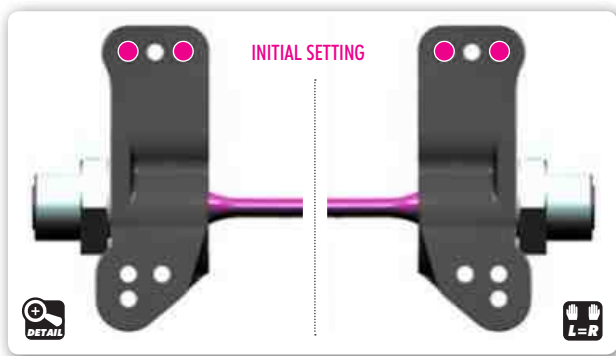
5. FRONT SUSPENSION



#333451
ALU ANTI-ROLL BAR PIVOT BALL 5.8 MM - SWISS 7075 T6 - HARDCOATED (2)

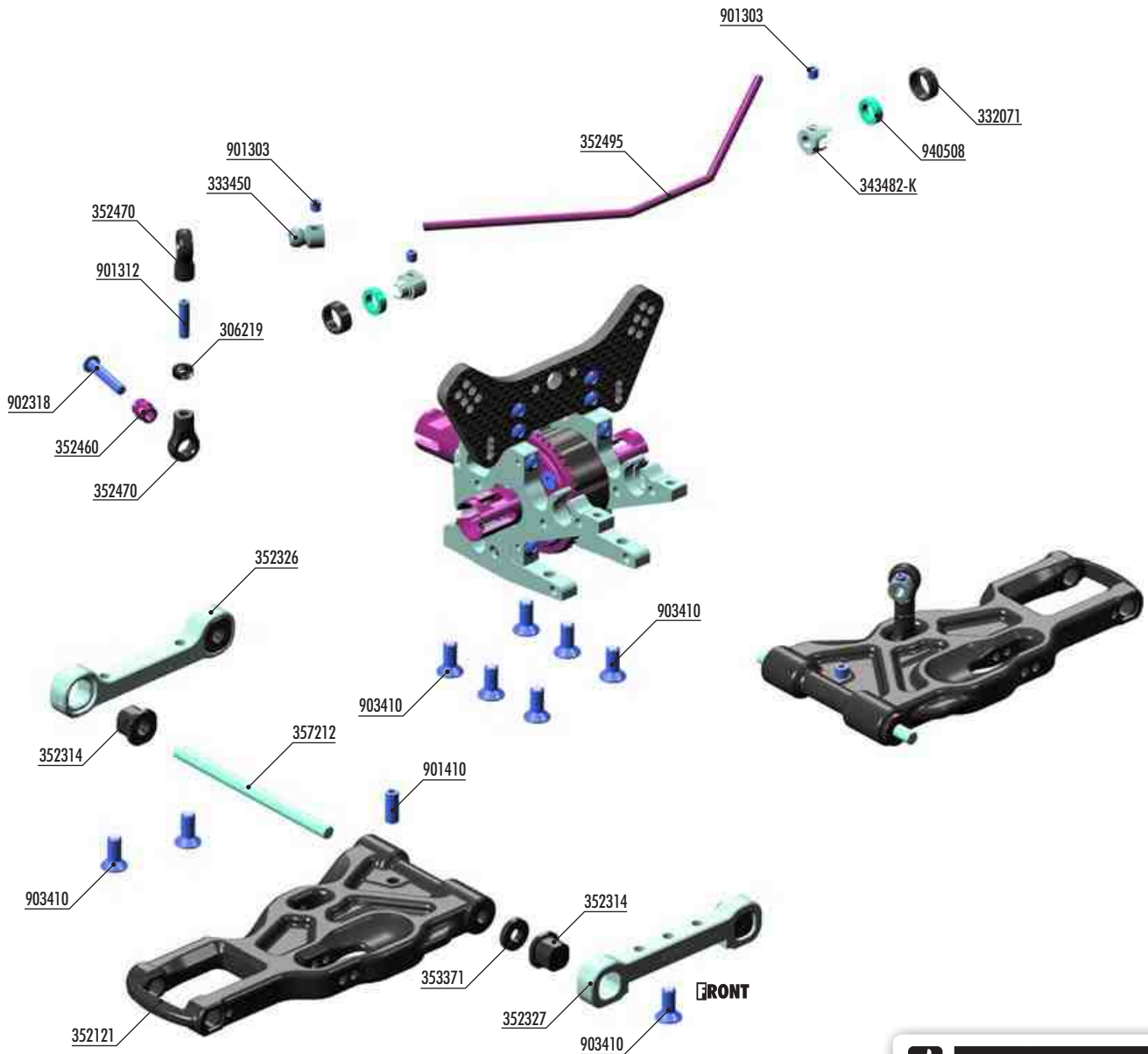

FRONT LOWER SUSP. ARMS			
OPTION	#352121-S	SOFT	OPTION
	#352121	MEDIUM	INCLUDED
	#352121-H	HARD	OPTION
	#352121-G	GRAPHITE	OPTION



ALU ANTI-ROLL BAR COLLAR			
OPTION	#343483-K	ø2.2mm	OPTION
	#343484-K	ø2.4mm	OPTION
	#343482-K	ø2.6mm	INCLUDED
	#343485-K	ø2.8mm	OPTION
	#343481-K	ø3.0mm	OPTION



FRONT ANTI-ROLL BARS			
OPTION	#352489	1.8mm	OPTION
	#352490	2.0mm	OPTION
	#352492	2.2mm	OPTION
	#352493	2.3mm	OPTION
	#352494	2.4mm	OPTION
	#352495	2.5mm	INCLUDED
	#352496	2.6mm	OPTION
	#352498	2.8mm	OPTION



- 306219 COMPOSITE SET OF SHIMS (4)
- 332071 COMPOSITE BALL-BEARING HUB (4)
- 333450 ANTI-ROLL BAR BALL JOINT 5.8 MM (2)
- 343482-K ALU CUTTED ANTI-ROLL BAR COLLAR ø2.6 - BLACK (2)
- 352121 C-HUB COMPOSITE FRONT LOWER SUSPENSION ARM - MEDIUM
- 352314 COMPOSITE SQUARE ADJ. ROLL CENTER BUSHINGS - V2 (2)
- 352326 ALU FRONT LOWER SUSP. HOLDER - REAR - SQUARE ADJ. ROLL-C.
- 352327 ALU FRONT LOWER SUSP. HOLDER - FRONT - SQUARE ADJ. ROLL-C.
- 352460 PIVOT BALL 5.8 (10)
- 352470 BALL JOINT 5.8 (8)
- 352495 FRONT ANTI-ROLL BAR 2.5MM

- 353371 SET OF COMPOSITE LOWER ARM SHIMS
- 357212 LOWER INNER PIVOT PIN F+R (2)
- 901303 HEX SCREW SB M3x3 (10)
- 901312 HEX SCREW SB M3x12 (10)
- 901410 HEX SCREW SB M4x10 (10)
- 902318 HEX SCREW SH M3x18 (10)
- 903410 HEX SCREW SFH M4x10 (10))
- 940508 BALL-BEARING 5x8x2.5 RUBBER SEALED - OIL (2)

5. FRONT SUSPENSION



353371
SHIM 4x10x2



901410
SB M4x10

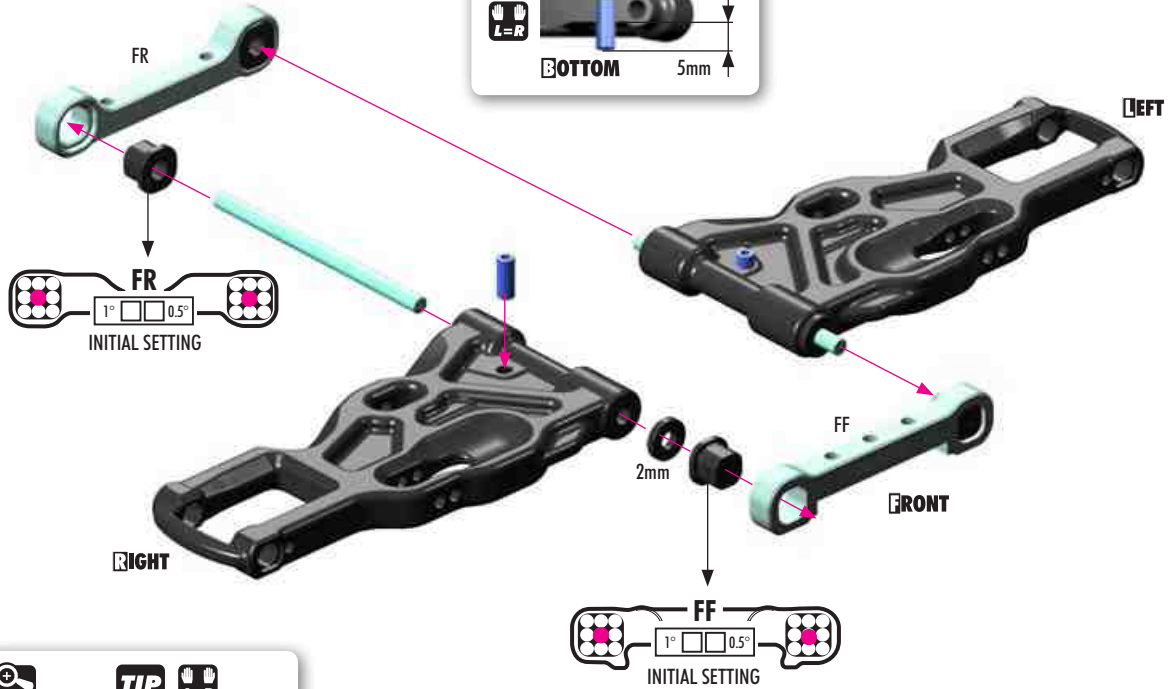
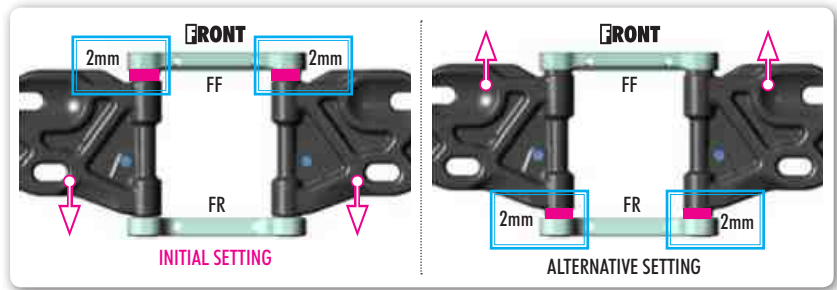

TIP If the suspension arms do not move freely, use a HUDY Arm Reamer to resize the holes.

(HUDY #107634)

OPTION	FRONT LOWER SUSP. ARMS		
#352121-S	SOFT	OPTION	
#352121	MEDIUM	INCLUDED	
#352121-H	HARD	OPTION	
#352121-G	GRAPHITE	OPTION	

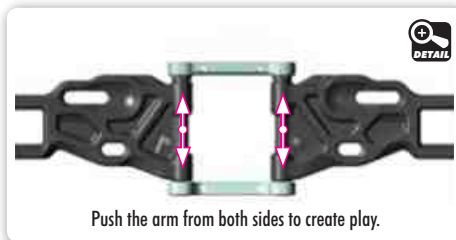
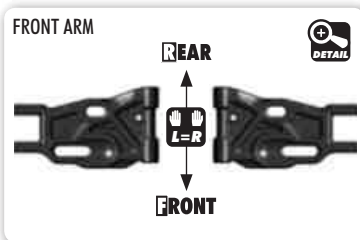

Eccentric bushings have two different offsets from the center.

- Middle position = 0.5 mm or 0.5° from center
- Outer position = 1 mm or 1° from center

TRACK-WIDTH			(mm)
FF	FR		
			= 308
			= 306
			= 310

ROLL CENTER			(mm)
FF	FR		
			= 1
			= 0
			= -1

The XRAY alu front lower suspension holders provide even greater range of adjustment for the front suspension. Using different combinations of eccentric bushings, fine adjustment of front kick-up, roll center, and front track-width can be obtained. For more information about the influence of kick-up, front track-width, and roll centers on car handling, please refer to HUDY Off-Road Set-up Book (#209099).

The tables below describe the amounts of kick-up, front track-width change depending on the combinations of eccentric bushings used with 0 and 1mm, 1° offset. The 0.5mm, 0.5° represents the half change.

SET-UP BOOK
KICK UP
ROLL CENTER DOWNSTOP
WHEELBASE
TRACK WIDTH

5. FRONT SUSPENSION



903410
SFH M4x10

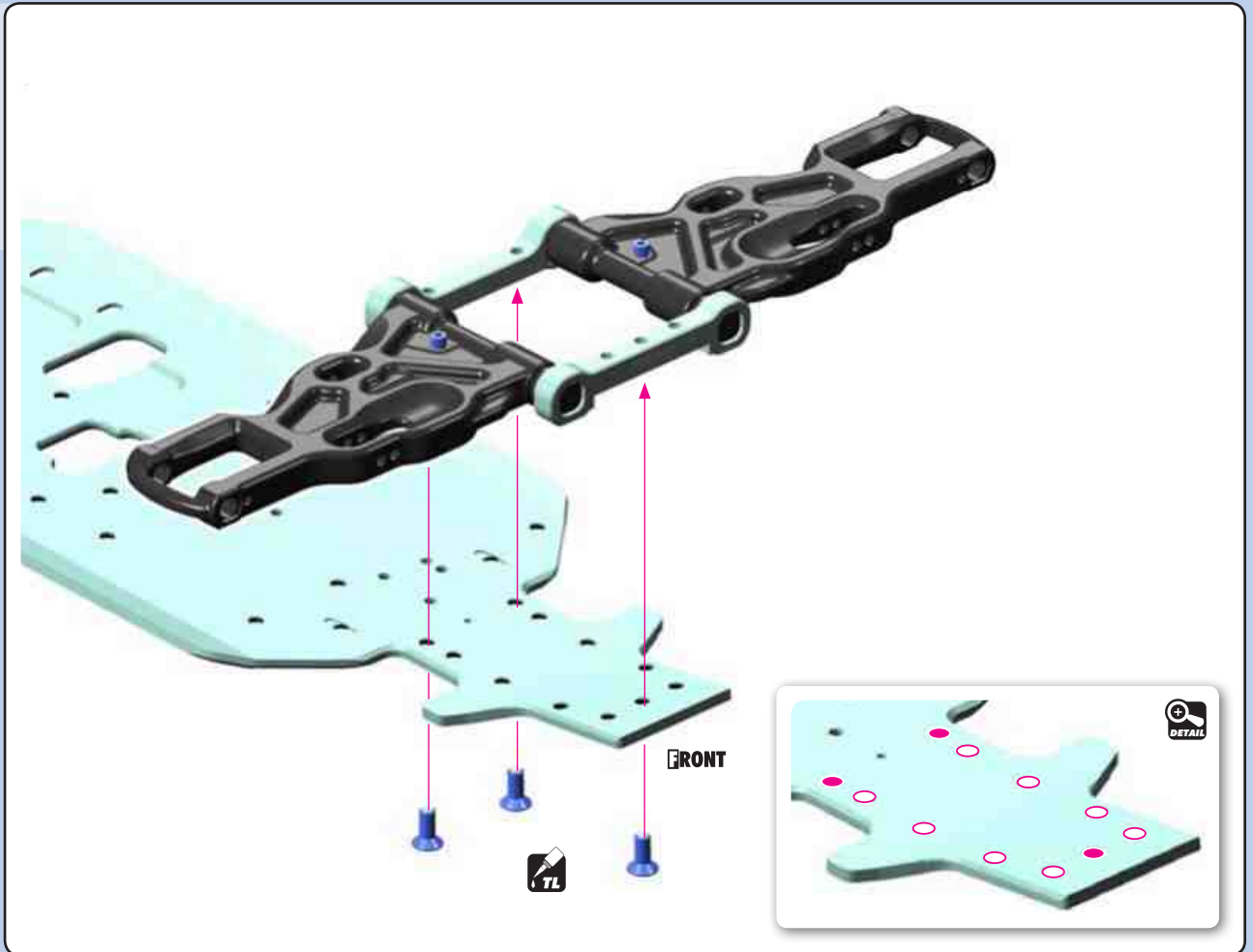

903410
SFH M4x10

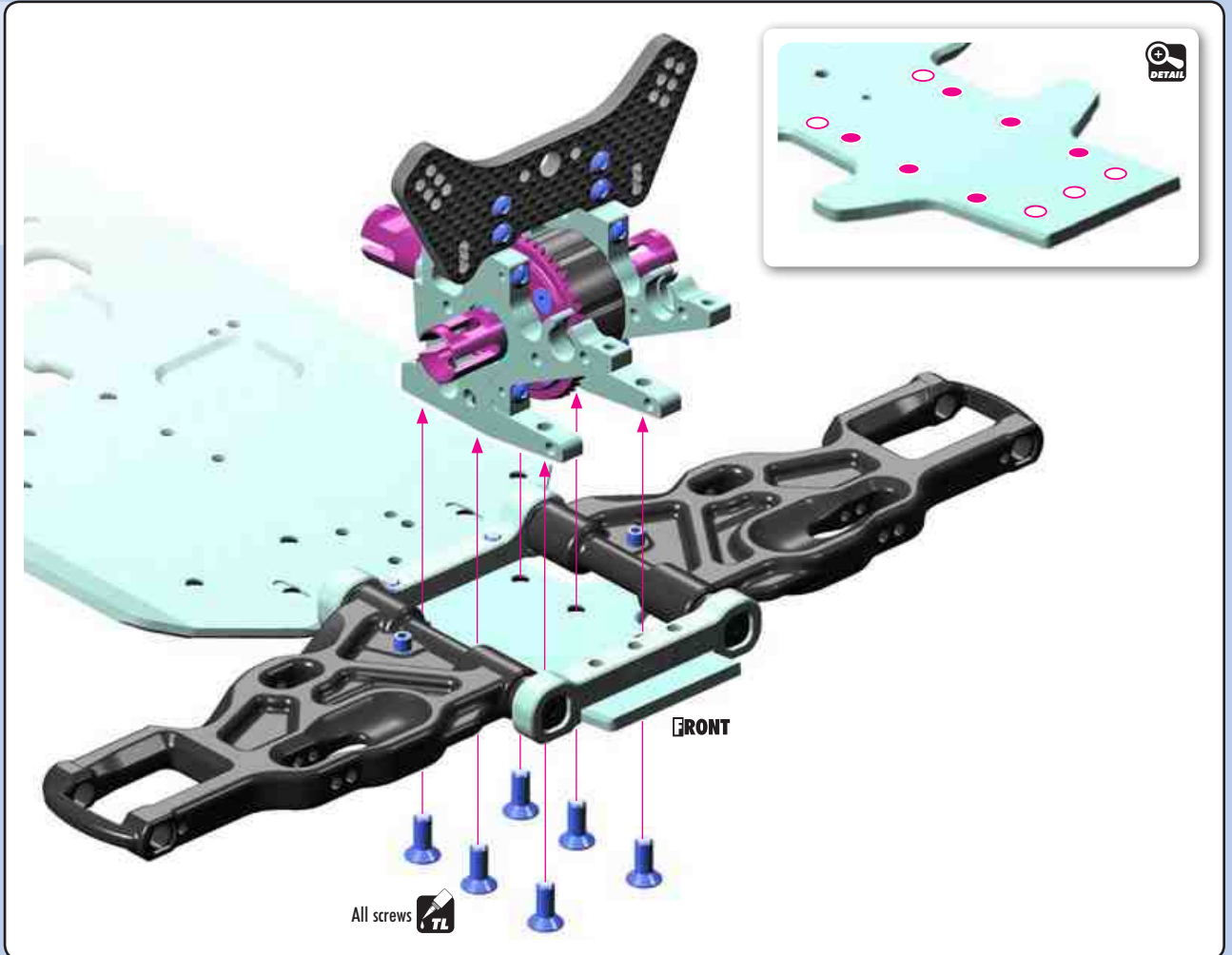

5. FRONT SUSPENSION

IO
306219
SHIM 3x6x2



901312
SB M3x12

2x **L=R**



TIP
Install the pivot balls with Professional Multi Tool (HUDY #183011).

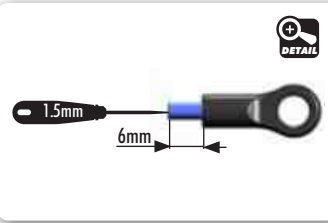

940508
BB 5x8x2.5

FRONT ANTI-ROLL BARS

BEARING OIL (HUDY #106230) Cut away excessive material.



OPTION

FRONT ANTI-ROLL BARS

#352489	1.8mm	OPTION
#352490	2.0mm	OPTION
#352492	2.2mm	OPTION
#352493	2.3mm	OPTION
#352494	2.4mm	OPTION
#352495	2.5mm	INCLUDED
#352496	2.6mm	OPTION
#352498	2.8mm	OPTION

901303
SB M3x3



902318
SH M3x18

STEP 4 DETAIL

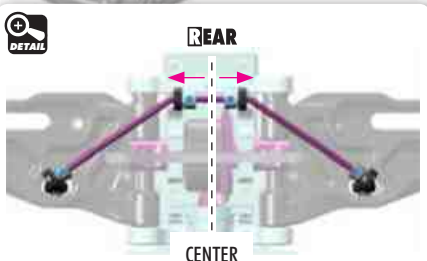
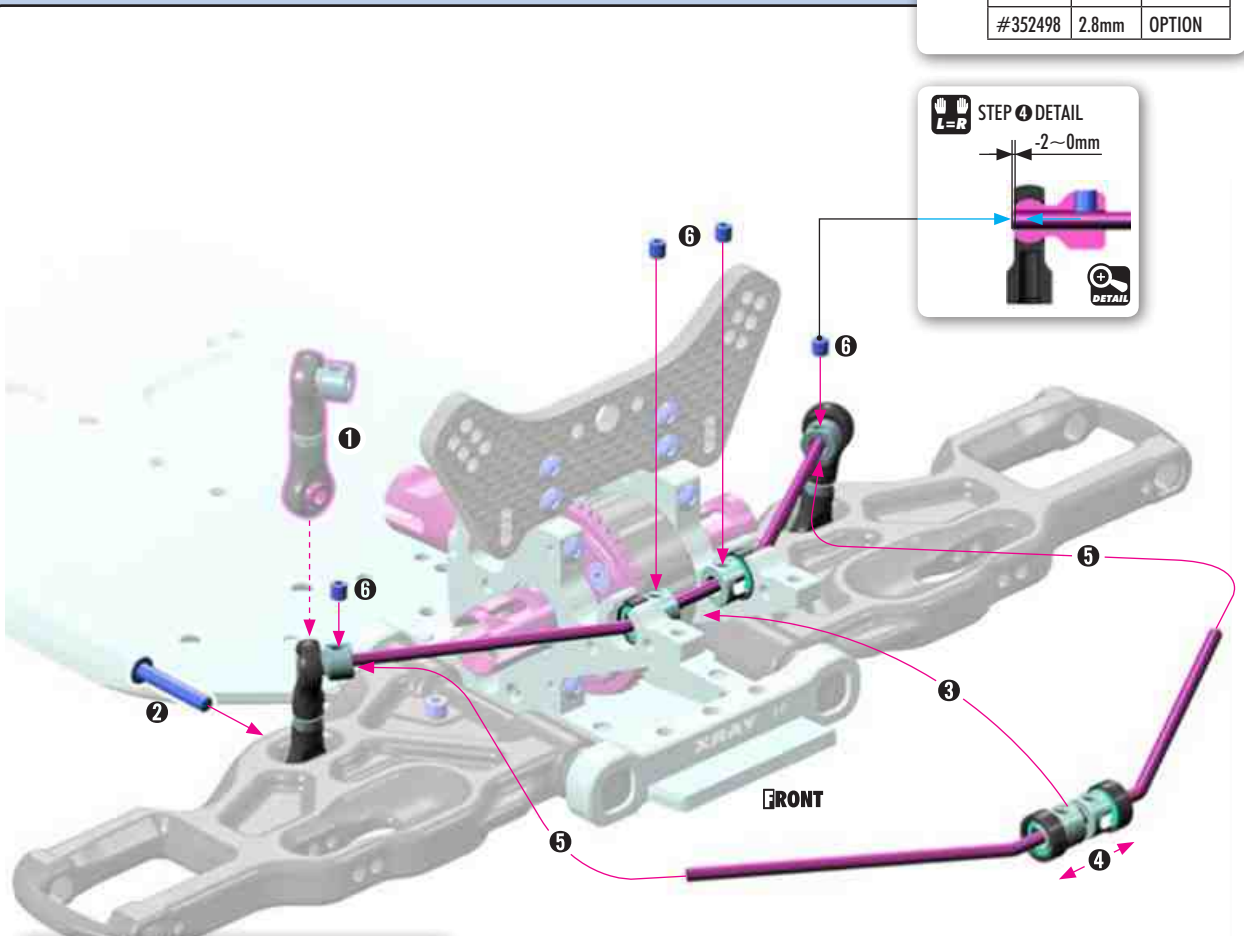
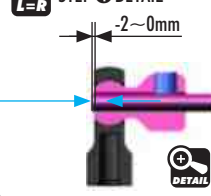

TOP
Set the bar into the center, remove the play in the bushings, and tighten the set-screws fully.



Step 4 check for free movement.

SET-UP BOOK
ANTI-ROLL BAR

6. FRONT SUSPENSION

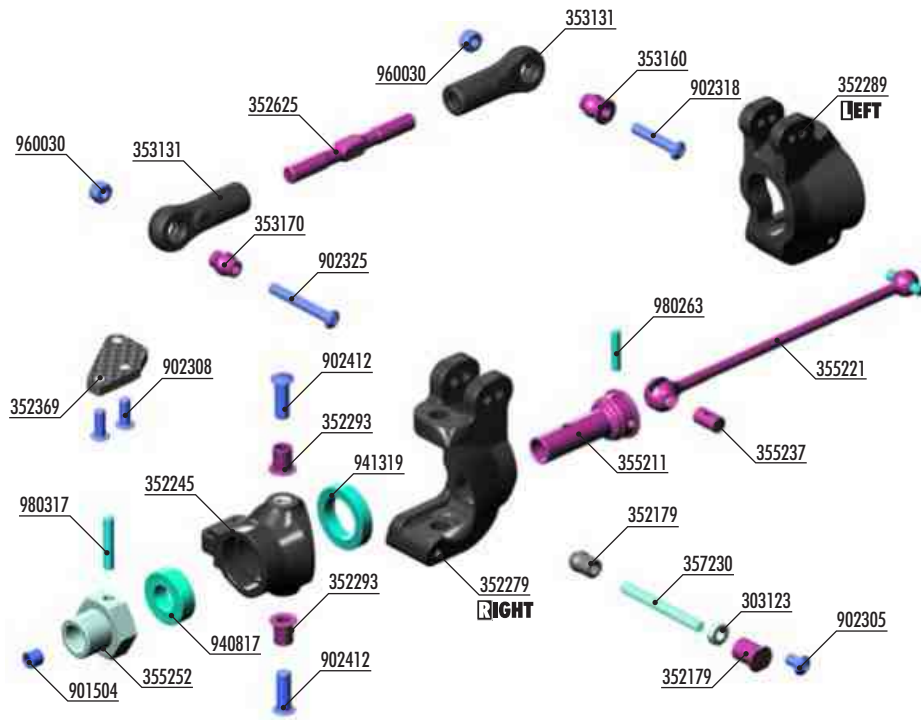

STEERING BLOCK			
OPTION	#352245	COMPOSITE	INCLUDED
	#352254	ALU*	OPTION

CASTER BLOCK - RIGHT				
OPTION	#352273	18° RIGHT	ALU*	OPTION
	#352277	16° RIGHT	COMP.	OPTION
	#352278	6° RIGHT	ALU*	OPTION
	#352279	6° RIGHT	COMP.	INCLUDED

CASTER BLOCK - LEFT				
OPTION	#352283	18° LEFT	ALU*	OPTION
	#352287	16° LEFT	COMP.	OPTION
	#352288	6° LEFT	ALU*	OPTION
	#352289	6° LEFT	COMP.	INCLUDED

*To use alu C-hub and alu steering blocks you need to use also these additional parts:

- *#352655 - Ball Stud 6.8mm with Backstop L=6mm - M4 (2)
- *#352292 - Steel Steering Block Pivot Pin (2)
- *#352294 - Composite Bushing for Alu Caster Block (2)

STEEL BALL MOUNT (2)	
OPTION	#352180

OFFSET WHEEL AXLES			
OPTION	#355250	0mm	OPTION
	#355251	+1mm	OPTION
	#355252	+2mm	INCLUDED

ECCENTRIC BUSHINGS			
OPTION	#352170	0° - STEEL	OPTION
	#352174	1° - STEEL	OPTION
	#352175	2° - STEEL	OPTION
	#352179	0° - COMP.	INCLUDED

BAG
06

- | | | | |
|--------|---|--------|--|
| 303123 | ALU SHIM 3x6x2.0MM (10) | 355252 | ALU WHEEL AXLE OFFSET "+2MM" - HARD COATED (2) |
| 352179 | COMPOSITE BUSHING & BALL MOUNT SET (2+2) | 357230 | FRONT LOWER OUTER PIVOT PIN (2) |
| 352245 | C-HUB STEERING BLOCK LB WITH ALU INSERTS | 901504 | HEX SCREW SB M5x4 (10) |
| 352279 | COMPOSITE C-HUB 6° RIGHT | 902305 | HEX SCREW SH M3x5 (10) |
| 352289 | COMPOSITE C-HUB 6° LEFT | 902308 | HEX SCREW SH M3x8 (10) |
| 352293 | STEEL C-HUB BUSHING (2) | 902318 | HEX SCREW SH M3x18 (10) |
| 352369 | GRAPHITE STEERING PLATE (2) | 902325 | HEX SCREW SH M3x25 (10) |
| 352625 | ADJ. TURNBUCKLE M5 L/R 46 MM - HUDY SPRING STEEL™ (2) | 902412 | HEX SCREW SH M4x12 (10) |
| 353131 | REAR UPPER INNER CAMBER LINK BALL JOINT - V3 (2) | 940817 | BALL-BEARING 8x16x5 RUBBER SEALED - OIL (2) |
| 353160 | MOUNTING BALL 6.8 (4) | 941319 | BALL-BEARING 13x19x4 RUBBER SEALED - OIL (2) |
| 353170 | PIVOT BALL 6.8 (4) | 960030 | NUT M3 (10) |
| 355211 | CVD DRIVE AXLE - HUDY SPRING STEEL™ | 980263 | PIN 2.5x13 (10) |
| 355221 | CVD UNIVERSAL DRIVE SHAFT 94MM - HUDY SPRING STEEL™ | 980317 | PIN 3x17 (10) |
| 355237 | CVD DRIVE SHAFT COUPLING - HUDY SPRING STEEL™ | | |

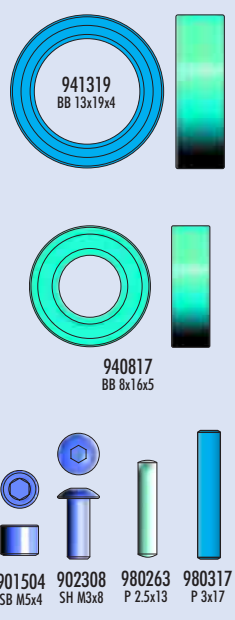

OFFSET WHEEL AXLES			
OPTION	#355250	0mm	OPTION
	#355251	+1mm	OPTION
	#355252	+2mm	INCLUDED

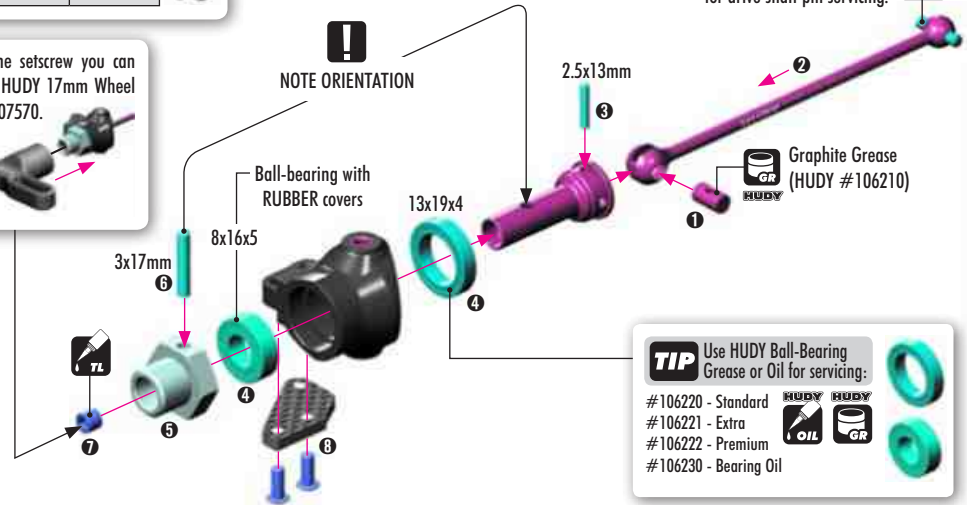
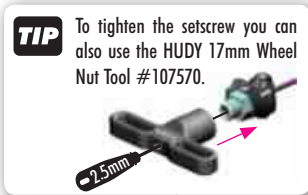

6. FRONT SUSPENSION



902412
SH M4x12

2x
L=R

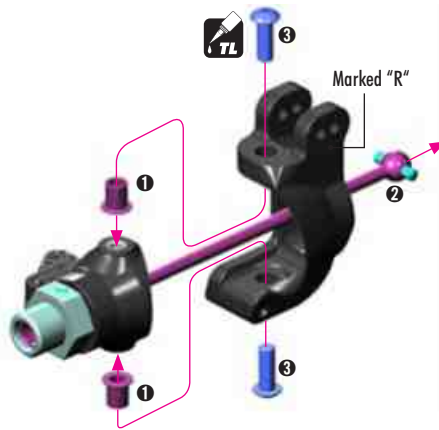

303123
SHIM 3x6x2



902305
SH M3x5

2x
L=R

OPTION #352180
STEEL BALL MOUNT (2)



TIP Press pivot ball into arm until it snaps into place.



ECCENTRIC BUSHINGS			
OPTION #352170	0° - STEEL		OPTION
#352174	1° - STEEL		OPTION
#352175	2° - STEEL		OPTION
#352179	0° - COMP.		INCLUDED

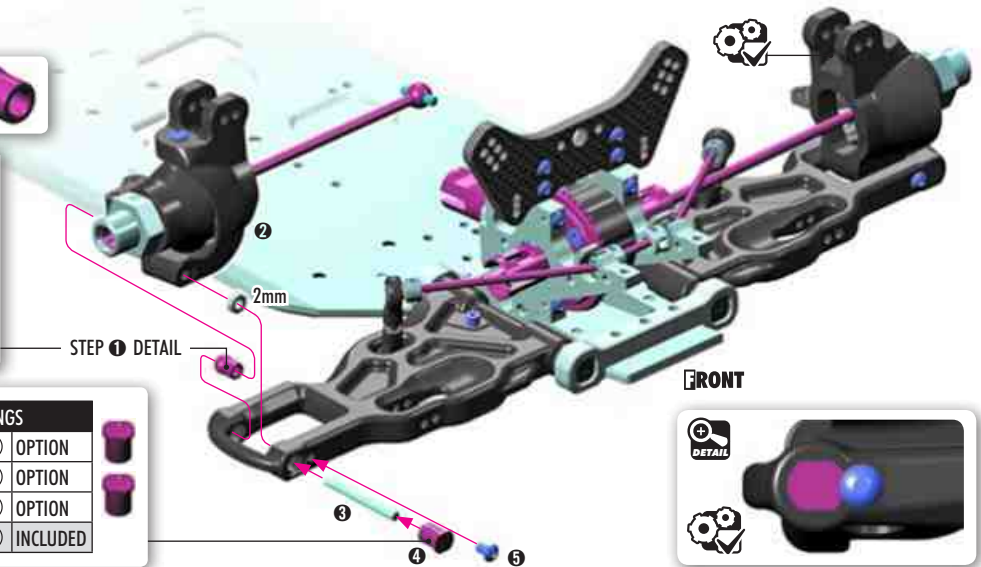

2x
L=R

TIP Install the pivot balls with Professional Multi Tool (HUDY #183011).

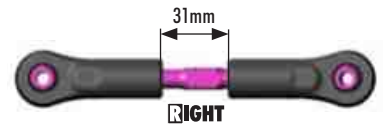
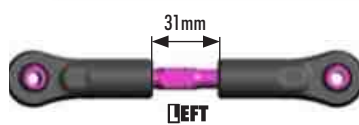
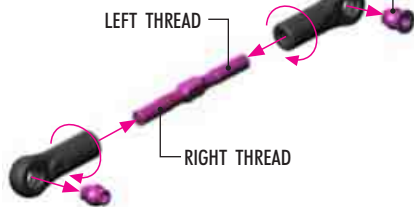

960030
N M3

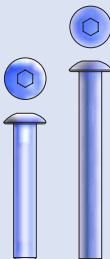

902318 SH M3x18 902325 SH M3x25

2x
L=R

NOTE ORIENTATION

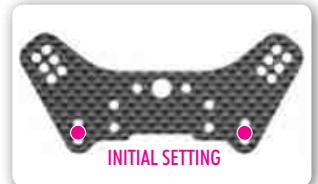
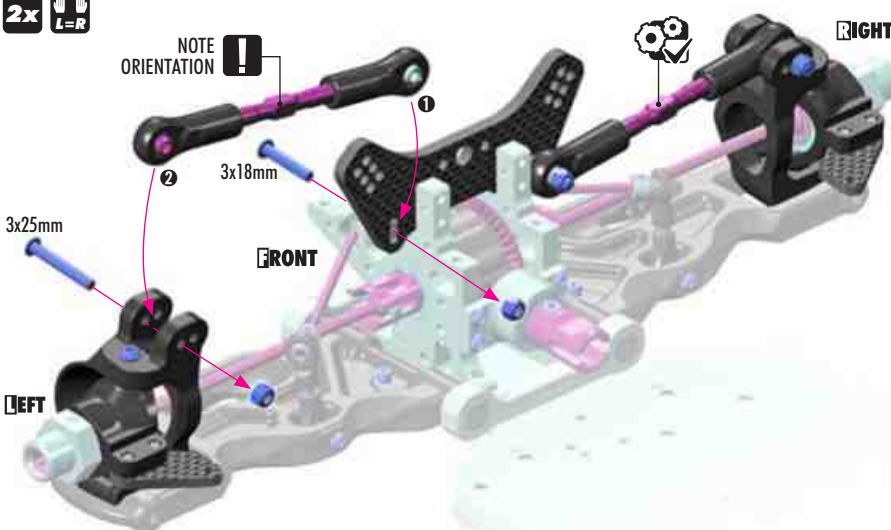

SET-UP BOOK

ROLL CENTER

7. STEERING

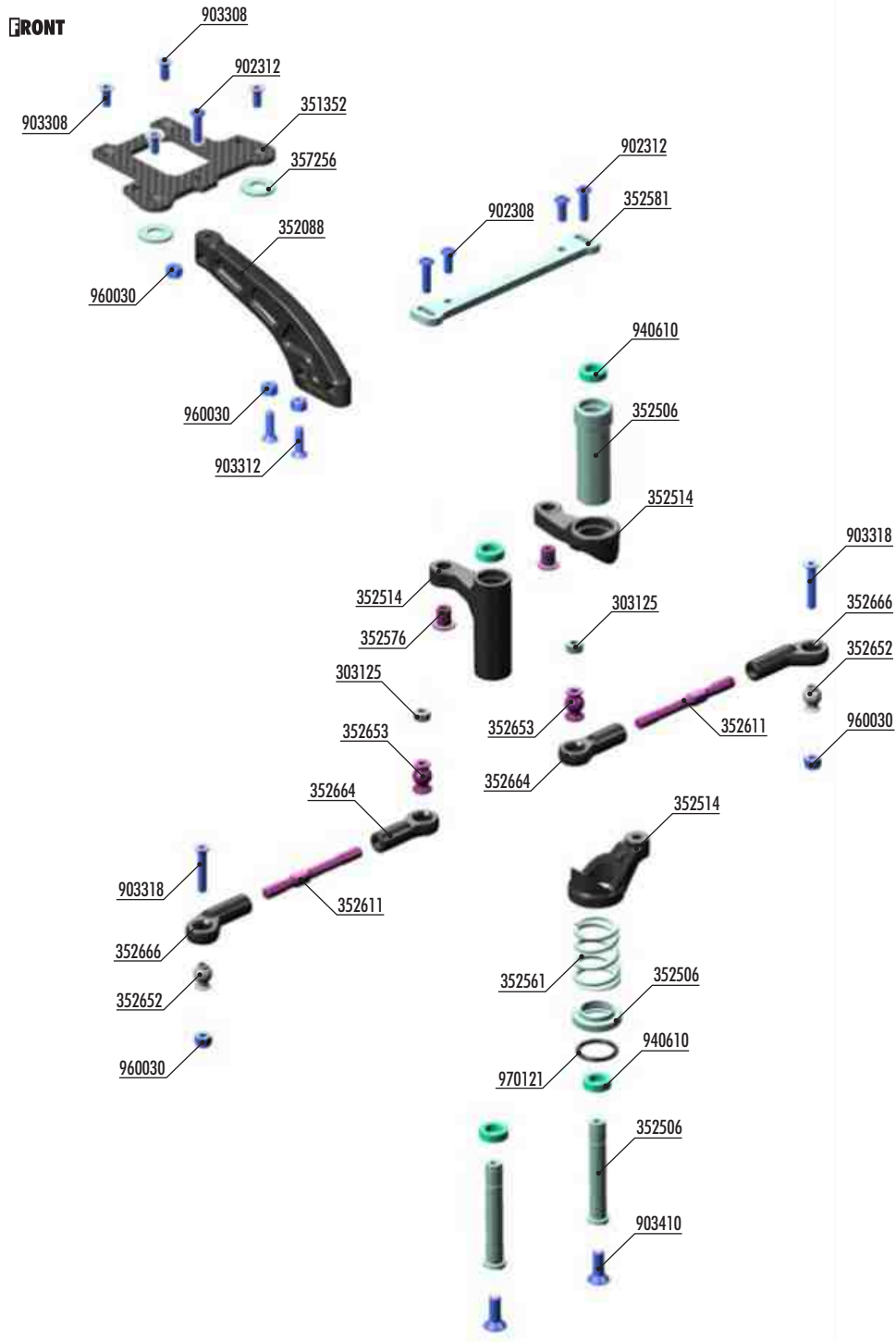

BAG

07

303125	ALU SHIM 3x6x3.0MM (10)	902308	HEX SCREW SH M3x8 (10)
351352	GRAPHITE UPPER PLATE 2.5MM	902312	HEX SCREW SH M3x12 (10)
352088	COMPOSITE FRONT BRACE	903308	HEX SCREW SFH M3x8 (10)
352506	SERVO SAVER WITH CHASSIS LOCK & HARD SPRING - G - SET	903312	HEX SCREW SFH M3x12 (10)
352514	COMPOSITE SERVO SAVER - GRAPHITE	903318	HEX SCREW SFH M3x18 (10)
352561	SERVO SAVER SPRING PROGRESSIVE	903410	HEX SCREW SFH M4x10 (10)
352576	STEERING PLATE BUSHING (2)	940610	BALL-BEARING 6x10x3 RUBBER SEALED - OIL (2)
352581	ALU STEERING PLATE - SWISS 7075 T6	960030	NUT M3 (10)
352611	ADJ. TURNBUCKLE M4 L/R 53MM - HUDY SPRING STEEL™ (2)	970121	O-RING 12.1 x 1.6 (10)
352652	BALL STUD 6.8MM (4)		
352653	BALL STUD 6.8MM WITH BACKSTOP - M3 (2)		
352664	COMPOSITE STEERING BALL JOINT 6.8MM - V3 (2)		
352666	COMPOSITE RELIEF STEERING BALL JOINT 6.8MM (2)		
357256	ALU SHIM 6x13x1MM (2)		



970121
O 12.1x1.6

SET-UP BOOK
SERVO SAVER

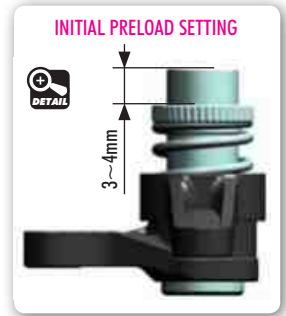
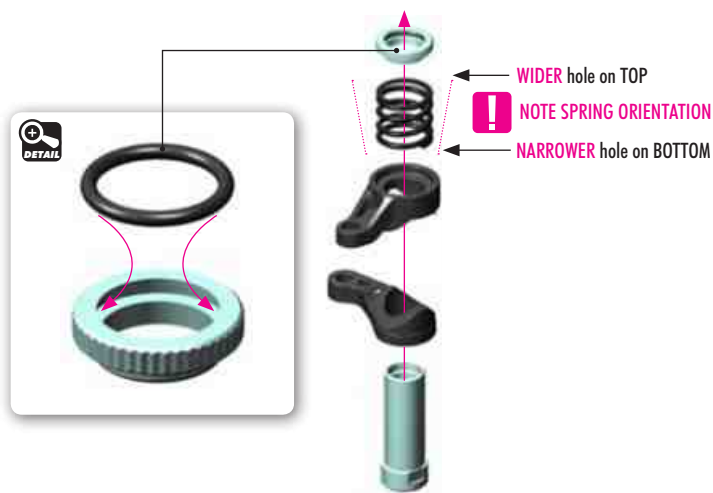

902308
SH M3x8



903410
SFH M4x10

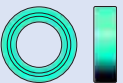

940610
BB 6x10x3

For servicing use
Bearing Oil (HUDY #106230).

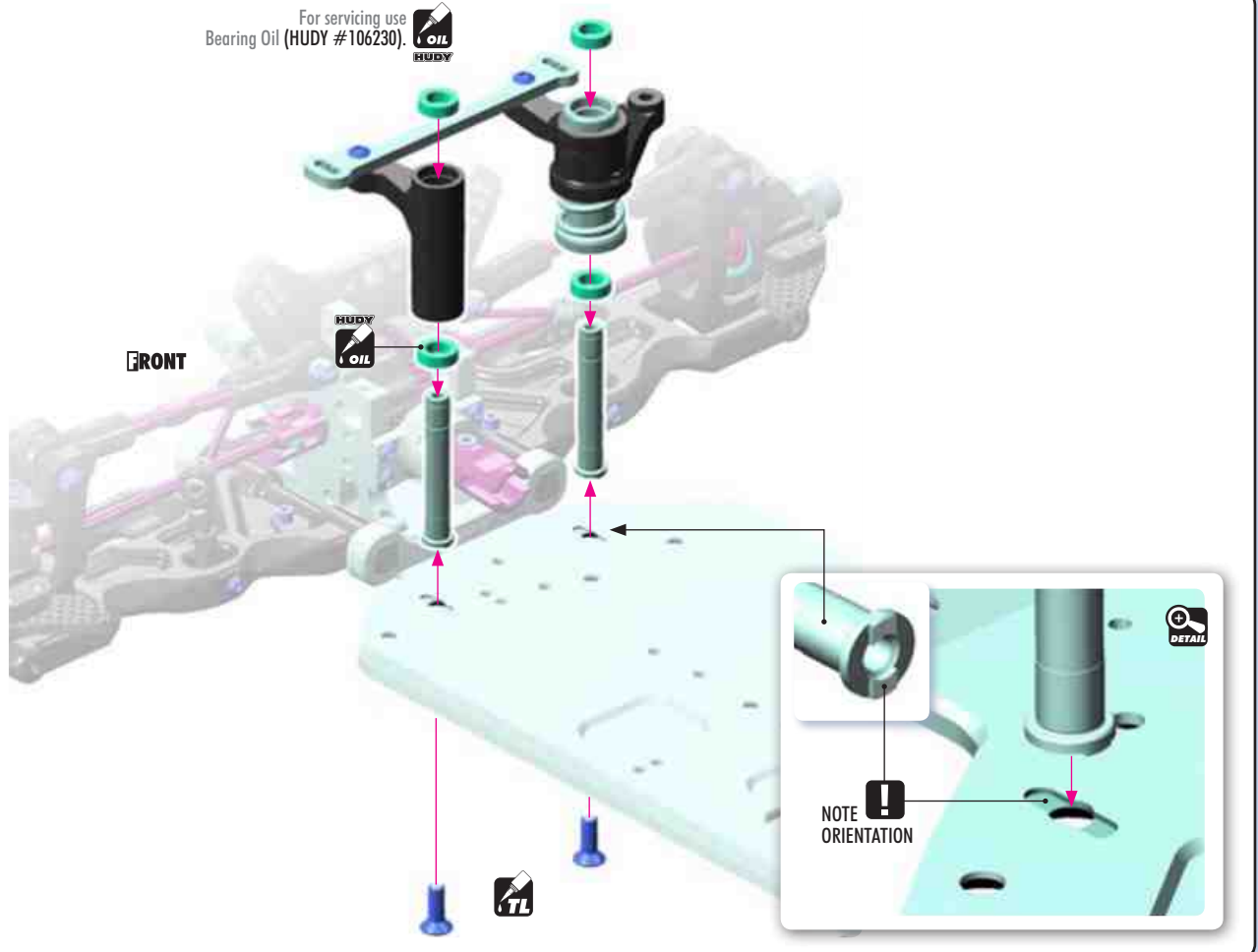

7. STEERING



357256
SHIM 6x13x1



902312
SH M3x12



903308
SFH M3x8



903312
SFH M3x12



960030
N M3

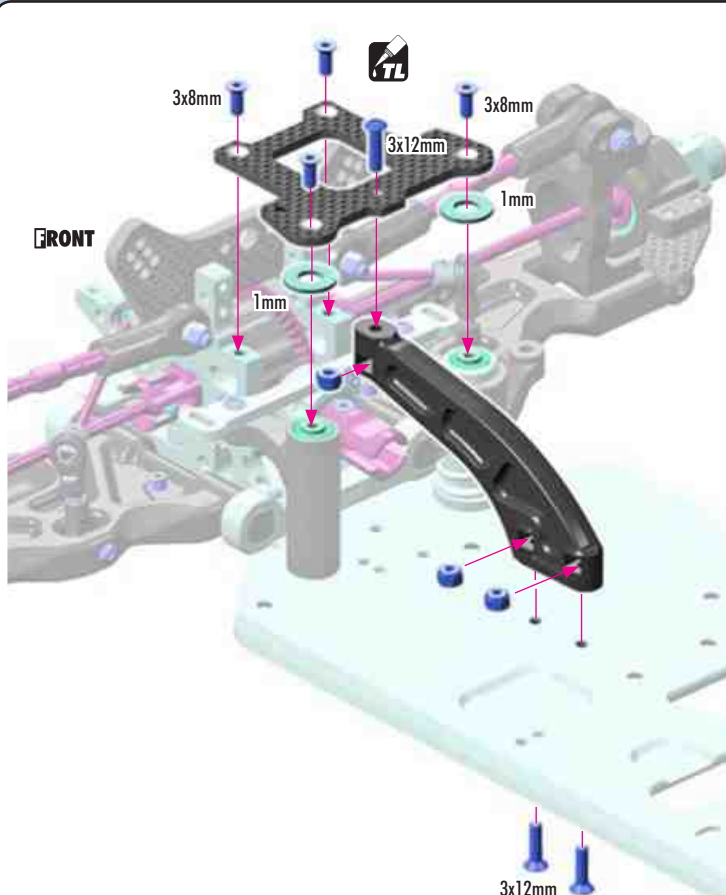



Check for free movement.

After the top deck assembly check for free movement of steering system.

2x 

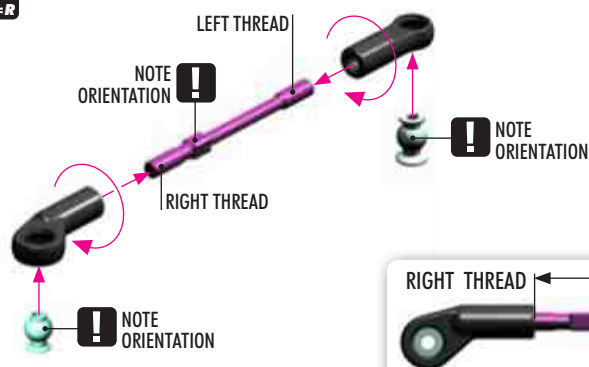

LEFT THREAD

NOTE ORIENTATION

RIGHT THREAD

NOTE ORIENTATION

NOTE ORIENTATION

TIP Use tools to tighten as shown.

Special Tool (HUDY #181090)

Turnbuckle Wrench 4mm (HUDY #181040)

Install the pivot balls with Professional Multi Tool (HUDY #183011).

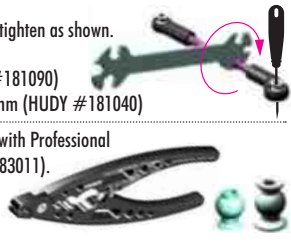



RIGHT THREAD ← 29mm → LEFT THREAD ← 29mm → RIGHT THREAD

LEFT RIGHT



303125
SHIM 3x6x3



902312
SH M3x12



903318
SFH M3x18



960030
N M3

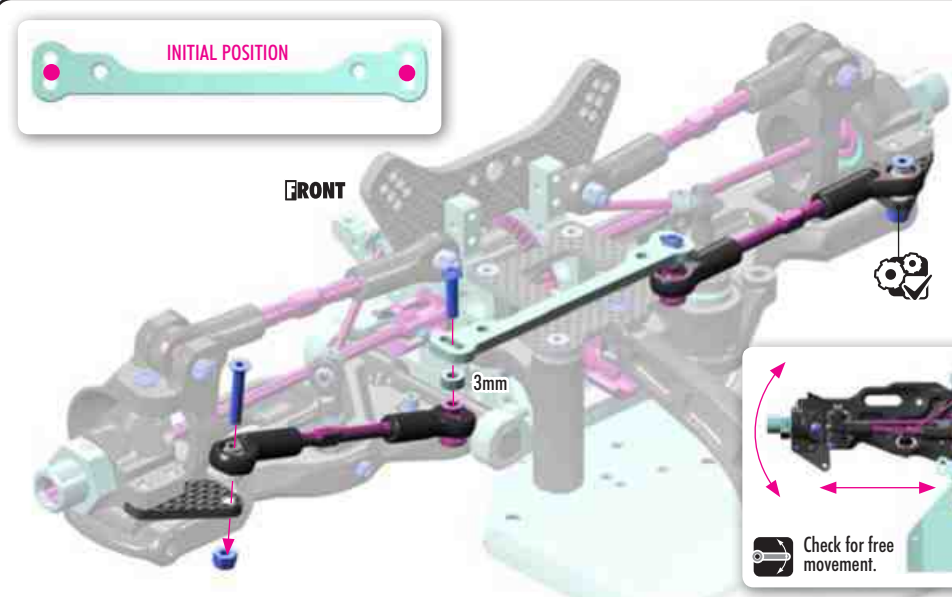

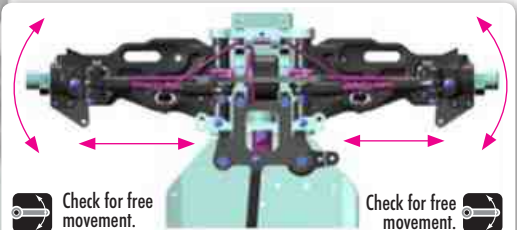

Check for free movement.

Check for free movement.

8. CENTRAL TRANSMISSION

#354010-G
COMPOSITE CENTER DIFFERENTIAL
MOUNTING PLATE SET - GRAPHITE



OPTION
COMPOSITE 2-SPEED GEARS

#345545	45T	2ND	OPTION
#345546	46T	2ND	OPTION
#345547	47T	2ND	INCLUDED
#345548	48T	1ST	OPTION
#345549	49T	1ST	OPTION
#345550	50T	1ST	INCLUDED

OPTION
GRAPHITE 2-SPEED GEARS

#345645	45T	2ND	OPTION
#345646	46T	2ND	OPTION
#345647	47T	2ND	OPTION
#345648	48T	1ST	OPTION
#345649	49T	1ST	OPTION
#345650	50T	1ST	OPTION

OPTION
#354113
SUPER-LIGHTWEIGHT VENTILATED BRAKE
DISK - PRECISION-GROUND (2)



OPTION
#354121
STEEL BRAKE PAD - LASER CUT (4)



OPTION
#354130
BRAKE PAD FIBER (4)



OPTION
#354132
BRAKE PAD "SLS" (4)



CA It is necessary to glue the brake pad with strong CA glue suitable for steel.

BAG

08

- 345530 ALU DRIVE FLANGE WITH ONE-WAY BEARING - SWISS 7075 T6
- 345540 COMPOSITE 2-SPEED GEAR BOX SHOE - SET
- 345547 COMPOSITE 2-SPEED GEAR 47T (2nd) - H
- 345550 COMPOSITE 2-SPEED GEAR 50T (1st)
- 345570 ADAPTER 2-SPEED
- 345581 GEAR BOX SPRING C=13.0 (2)
- 353083 COMPOSITE REAR BRACE
- 354010 CENTER DIFF MOUNTING PLATE - SET
- 354033 COMPOSITE 2-SPEED HOLDER PLATE (2)
- 354063 ALU BRAKE CAM POST & ROD (2+2) HARD COATED
- 354080 COMPOSITE BUSHING FOR DIFF MOUNTING PLATE (2)
- 354110 VENTILATED BRAKE DISK - LASER CUT - PRECISION-GROUND
- 354131 GLUED BRAKE PADS SET-ULTRA EFFICIENT (4)
- 354210 2-SPEED SHAFT - HUDY SPRING STEEL™
- 354221 CARRIER FOR 2-SPEED GEAR (2nd) - SWISS 7075 T6
- 354252 GT GRAPHITE CENTER MOUNTING PLATE 2.5MM
- 354261 CENTRAL TRANSM. OUTDRIVE ADAPTER - HUDY SPRING STEEL™ (2)
- 355433 FRONT CENTRAL DOGBONE DRIVE SHAFT 88MM - HUDY SPRING STEEL™

- 355633 REAR CENTRAL DOGBONE DRIVE SHAFT 98MM - HUDY SPRING STEEL™
- 372176 SPRING 4.25 COILS 3.6x6x0.4MM; C=1.5 - GOLD (SOFT) (2)
- 901304 HEX SCREW SB M3x4 (10)
- 901305 HEX SCREW SB M3x5 (10)
- 901504 HEX SCREW SB M5x4 (10)
- 902312 HEX SCREW SH M3x12 (10)
- 902314 HEX SCREW SH M3x14 (10)
- 902316 HEX SCREW SH M3x16 (10)
- 902330 HEX SCREW SH M3x30 (10)
- 903306 HEX SCREW SFH M3x6 (10)
- 903308 HEX SCREW SFH M3x8 (10)
- 903412 HEX SCREW SFH M4x12 (10)
- 930816 BALL-BEARING 8x16x5 RUBBER SEALED - OIL (2)
- 950814 BALL-BEARING 8x14x4 FLANGED - STEEL SEALED - OIL (2)
- 960040 NUT M4 (10)
- 981310 PIN 3x10 (10)
- 983404 ROLLER PIN 4x4 MM (2)

8. CENTRAL TRANSMISSION



902316
SH M3x16

2x F=R

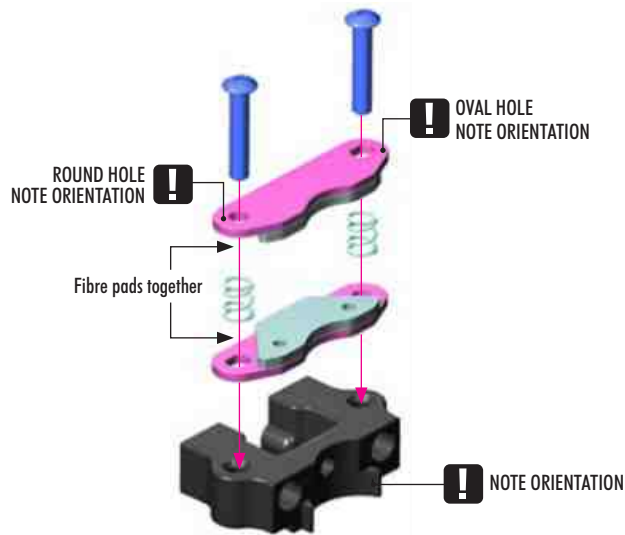

Temporarily insert brake disk between pads to set correct gap.



#354121
STEEL BRAKE PAD - LASER CUT (4)



#354130
BRAKE PAD FIBER (4)



#354132
BRAKE PAD "SLS" (4)



It is necessary to glue the brake pad with strong CA glue suitable for steel.



ASSEMBLY VIEW



901304
SB M3x4



903308
SFH M3x8

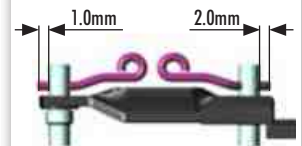
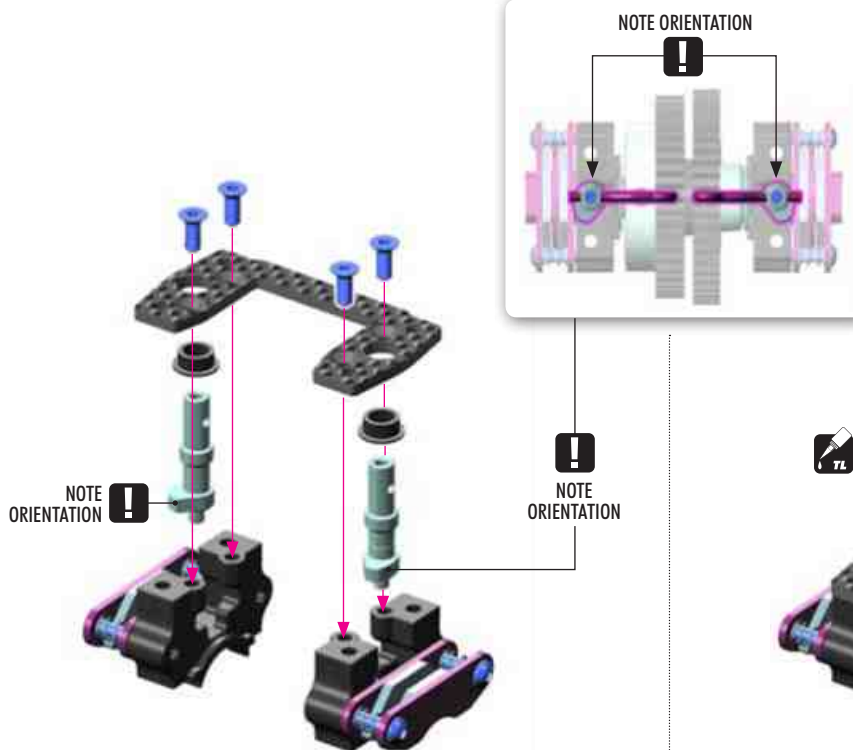

8. CENTRAL TRANSMISSION



903308
SFH M3x8

!
NOTE ORIENTATION
OF ALL PARTS

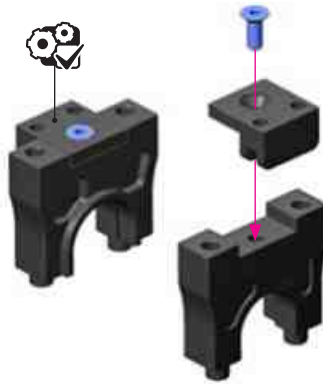

#354010-G
COMPOSITE CENTER DIFFERENTIAL
MOUNTING PLATE SET - GRAPHITE



903412
SFH M4x12

! NOTE ORIENTATION

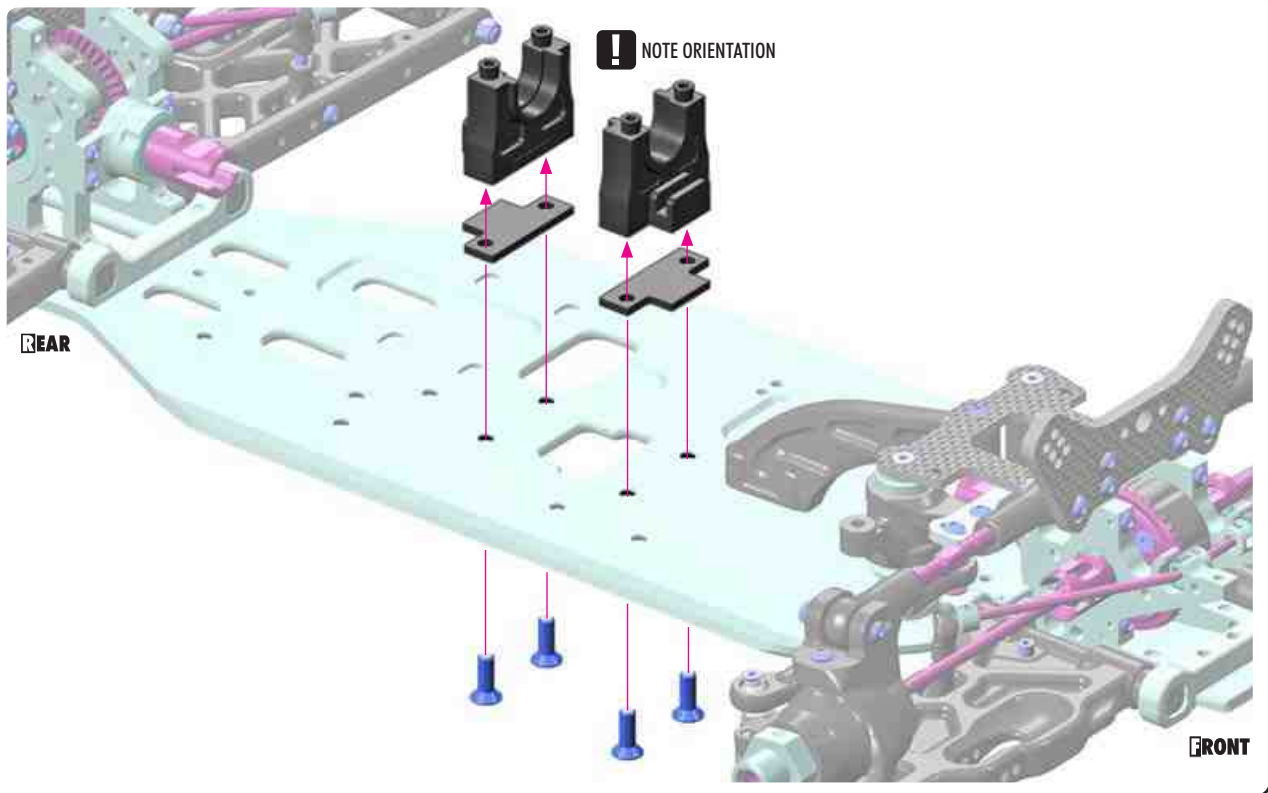

901305
SB M3x5



902314
SH M3x14



983404
RP 4x4

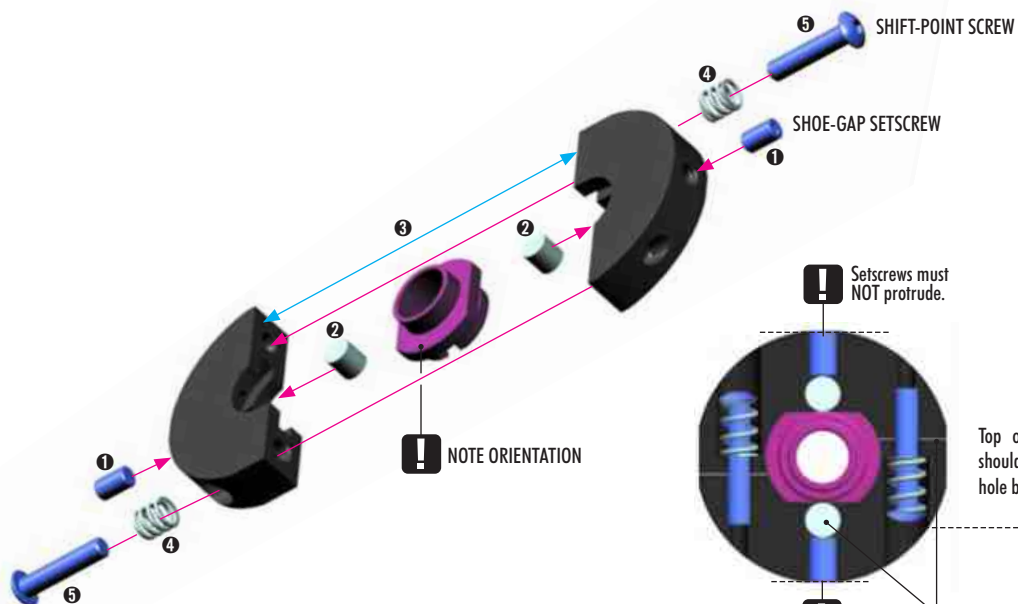

! NOTE ORIENTATION

! Setscrews must
NOT protrude.

Top of screw head
should be level with
hole bottom edge.

! Do not overtighten gap-setting
setscrews. Only tighten until roller
pins contact the center hub.



8. CENTRAL TRANSMISSION

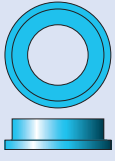

950814
BB 8x14x4



903306
SFH M3x6



903306
SFH M3x6



901504
SB M5x4



930816
BB 8x16x5



981310
P 3x10

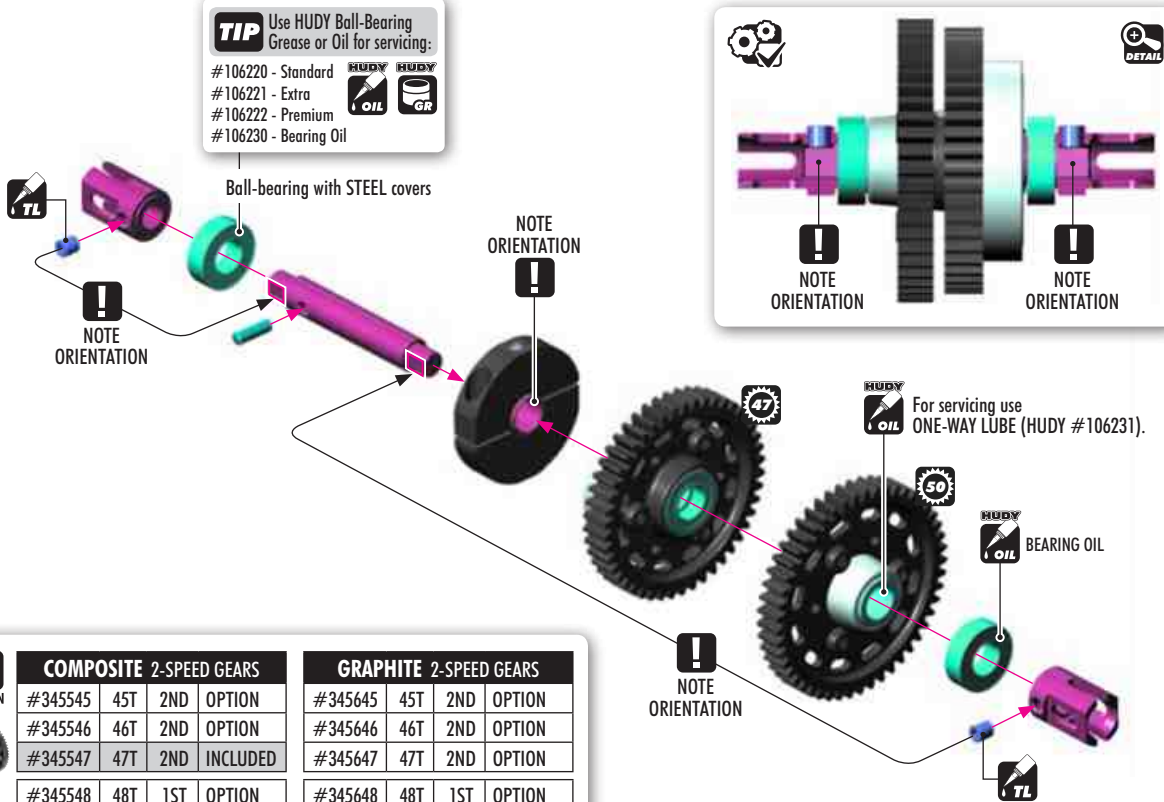

OPTION	COMPOSITE 2-SPEED GEARS				GRAPHITE 2-SPEED GEARS			
	#345545	45T	2ND	OPTION	#345645	45T	2ND	OPTION
	#345546	46T	2ND	OPTION	#345646	46T	2ND	OPTION
	#345547	47T	2ND	INCLUDED	#345647	47T	2ND	OPTION
	#345548	48T	1ST	OPTION	#345648	48T	1ST	OPTION
	#345549	49T	1ST	OPTION	#345649	49T	1ST	OPTION
	#345550	50T	1ST	INCLUDED	#345650	50T	1ST	OPTION

8. CENTRAL TRANSMISSION

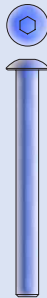

902330
SH M3x30

REAR

98mm

FRONT

88mm

! NOTE ORIENTATION OF ALL PARTS

OPTION #354113
SUPER-LIGHTWEIGHT VENTILATED BRAKE DISK - PRECISION-GROUND (2)

REUDY OIL
All screws

Before inserting 3x30 long screws, loosen the four flat-head screws in the upper plate by 1/2 turn (CCW). Tighten all screws after assembly.



902312
SH M3x12



903412
SFH M4x12



960040
N M4

REAR

OPTION #353281
GT GRAPHITE BRACES FOR REAR COMPOSITE BRACE - SET for extra stiffness adjustment.

960030

353281

353281

902312

9. FUEL TANK & ENGINE



ALU PINION GEARS

#358422	14/18T	INCLUDED
#358421	13/18T	OPTION
#358420	13/17T	OPTION

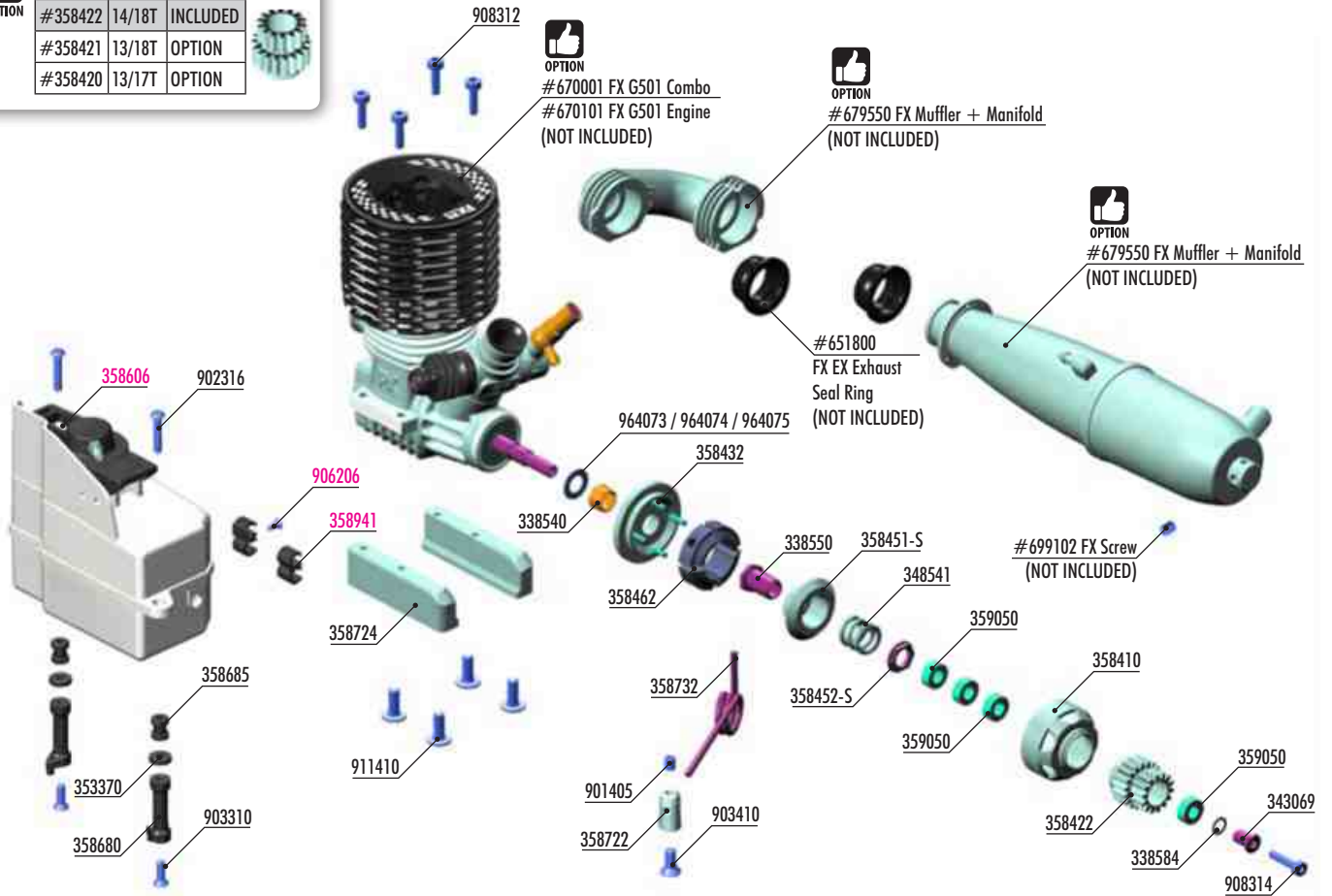

#358661 GRAPHITE 150CC FUEL TANK GUARD



#358709 ALU MONOBLOCK ENGINE MOUNT



ALU STAND FOR ENGINE MOUNT

#358718	FX, NOVAROSS, MAX, SIRIO	OPTION
#358719	PICCO, REDS, ORION, LRP, OS, U. RACING	OPTION



#358400 XRAY COMPLETE 4-SHOE CLUTCH SET



4-SHOE CLUTCH SHOES

#	DESCRIPTION	WEIGHT	GRIP	STATUS
#358457	ALU HARD (4)	1.00g	HIGH	OPTION
#358456	ALU MED (4)	1.00g	HIGH	OPTION
#358461	GRAPHITE (4)	1.00g	HIGH	OPTION
#358460	ALU HARD (4)	1.15g	HIGH	OPTION
#358459	ALU MEDIUM (4)	1.15g	HIGH	INCLUDED
#358458	ALU SOFT (4)	1.15g	LOW	OPTION



CLUTCH SPRINGS (4pcs)

#	TYPE	COLOR	RPM	STATUS
#358480	SOFT	GOLD	EARLY	INCLUDED
#358481	MEDIUM	GREY	LATE	OPTION
#358482	HARD	SILVER	LATE	OPTION

BAG



- 338540 FLYWHEEL COLLAR 7MM
- 338550 FLYWHEEL NUT - HUDY SPRING STEEL™
- 343069 STEEL BUSHING (2)
- 348541 CLUTCH SPRING - MEDIUM - V2
- 353370 SET OF COMPOSITE REAR HUB CARRIER SHIMS
- 358403 GT 4-SHOE CLUTCH FOR ALU CLUTCH BELL - SET
- 358410 GT 2-SPEED ALU CLUTCH BELL - LIGHTWEIGHT
- 358422 ALU PINION GEAR 14/18T
- 358432 GT ALU 4-SHOE FLYWHEEL
- 358451-S GT ALU 4-SHOE CLUTCH PRESSURE SLEEVE
- 358452-S GT 4-SHOE FLYWHEEL NUT
- 358462 GT COMPOSITE CLUTCH 4-SHOE - GRAPHITE
- 358680 FUEL TANK MOUNTING POST (2)
- 358685 FUEL TANK MOUNTING GROMMET (4)
- 358722 EXHAUST WIRE MOUNT SET - LONG
- 358724 ALU ENGINE MOUNT - CNC MACHINED (L+R)
- 358732 EXHAUST MOUNTING WIRE 100MM

- 338584 SHIM 5x7x0.2 (10)
- 359050 BALL-BEARING 5x10x4 STEEL SEALED - GREASE (2)
- 901405 HEX SCREW SB M4x5 (10)
- 902316 HEX SCREW SH M3x16 (10)
- 903310 HEX SCREW SFH M3x10 (10)
- 903410 HEX SCREW SFH M4x10 (10)
- 908312 HEX SCREW (CAP HEAD) 3x12 (10)
- 908314 HEX SCREW (CAP HEAD) 3x14 (10)
- 911410 HEX SCREW FLANGED SH M4x10 (10)
- 964073 WASHER S 7x10x0.2 (10)
- 964074 WASHER S 7x10x0.3 (10)
- 964075 WASHER S 7x10x0.5 (10)

- 358606 FUEL TANK 150CC WITH FLOATING FILTER & TRANSIENT JET
- 906206 SCREW PHILLIPS FH 2.2x6 (10)
- 358941 COMPOSITE TUBING HOLDER FOR FUEL TANK (2)

9. FUEL TANK & ENGINE



908312
SCH M3x12



964073
5 7x10x0.2



964074
5 7x10x0.3



964075
5 7x10x0.5



! IMPORTANT!



!

When installing the engine, first check that the drive shaft does not touch the engine. If it does, remove some material from the engine mount as shown to make some room between engine and shaft.

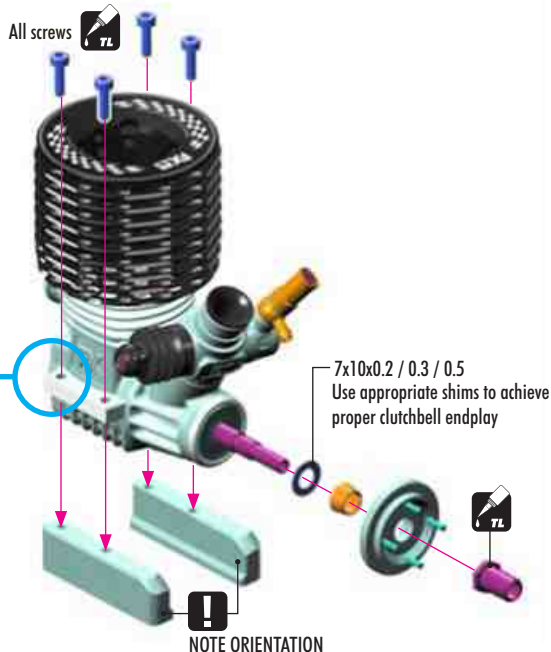

#358709

ALU MONOBLOCK ENGINE MOUNT



#358718

ALU STAND FOR ENGINE MOUNT
(FX, NOVAROSSO, MAX, SIRIO)



#358719

ALU STAND FOR ENGINE MOUNT
(PICCO, REDS, ORION, LRP, OS, U. RACING)

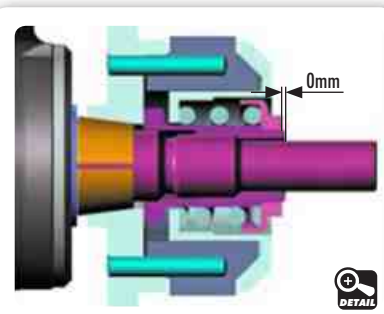
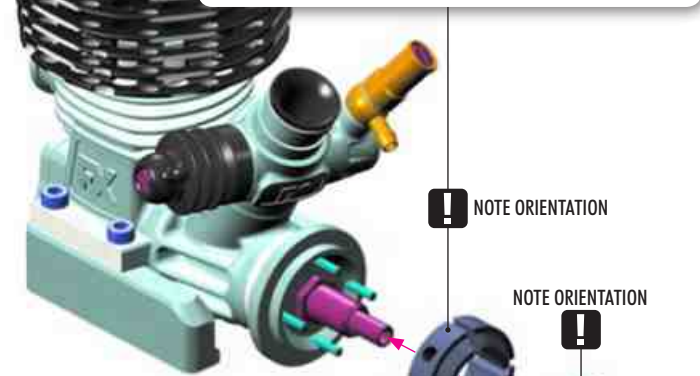
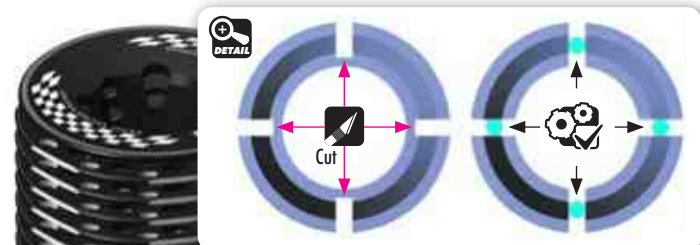

#358400

XRAY COMPLETE 4-SHOE CLUTCH SET



4-SHOE CLUTCH SHOES

			GRIP	
#358457	ALU HARD (4)	1.00g	HIGH	OPTION
#358456	ALU MED (4)	1.00g		OPTION
#358461	GRAPHITE (4)	1.00g		OPTION
#358460	ALU HARD (4)	1.15g	LOW	OPTION
#358459	ALU MEDIUM (4)	1.15g		INCLUDED
#358458	ALU SOFT (4)	1.15g		OPTION



CLUTCH SPRINGS (4pcs)

			RPM	
#358480	SOFT	GOLD	EARLY	INCLUDED
#358481	MEDIUM	GREY		OPTION
#358482	HARD	SILVER		LATE

9. FUEL TANK & ENGINE



338584
S 5x7x0.2



359050
BB 5x10x4



908314
SCH M3x14



OPTION

ALU PINION GEARS

#358422	14/18T	INCLUDED
#358421	13/18T	OPTION
#358420	13/17T	OPTION



TIP



OPTION

TO TIGHTEN THE 17T OR 18T PINION GEAR USE THE OPTIONAL #349901 XRAY PINION TOOL (19-21T / 16-18T).



These bearings must still be regularly serviced and replaced when worn out.



GR

SET-UP BOOK

CLUTCH SPRINGS
CLUTCH SHOE



911410
SHF M4x10

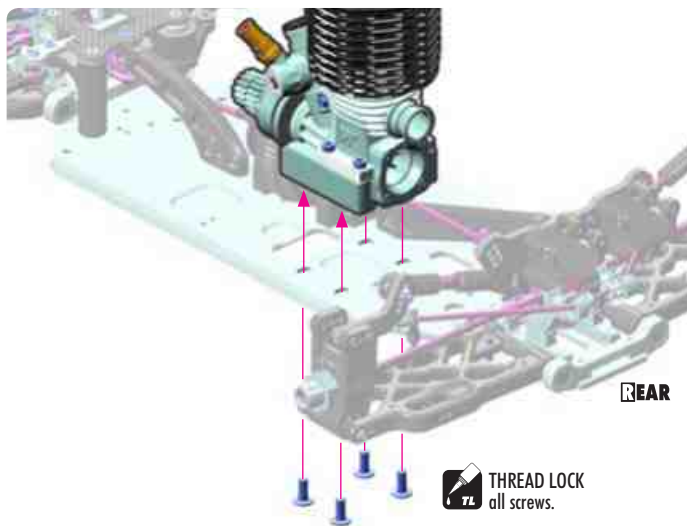

REAR

TL THREAD LOCK
all screws.



DETAIL



GEAR MESH

Adjust gear mesh so there is minimal play between the gears.

Too tight gear mesh will put excessive strain on all parts and damage the parts. Too loose gear mesh may result in stripped gears.

SET-UP BOOK

GEARING
GEAR MESH ADJ.



907258
SP 2.5x8

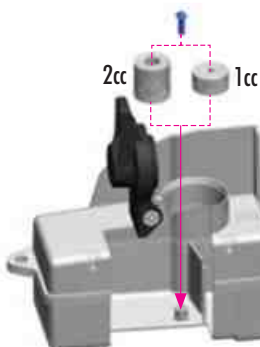

The fuel tank has the larger fuel volume and includes OPTIONAL tank inserts for decreasing the volume of the tank. Using the inserts allows you to adjust the volume of fuel inside the tank; this works in conjunction with variables such as fuel filter capacity and/or length of fuel line to ensure you have the legal fuel volume limit for racing.

Tube holders are easily connected to the fuel tank by screws. Using screws is much more secure than using glue to attach the holders to the fuel tank.

2CC FUEL TANK INSERT

The larger insert decreases the fuel tank volume by 2cc, and is recommended for use when the fuel filter is used.



NOTE ORIENTATION



1CC FUEL TANK INSERT

The smaller insert decreases the fuel tank volume by 1cc.



NOTE ORIENTATION



NOTE: The fuel tank insert can be easily mounted to the bottom of the fuel tank using the provided screw, when the fuel tank cap is opened fully.

9. FUEL TANK & ENGINE



353370
SHIM 3x9x2



902316
SH M3x16



903310
SFH M3x10



906206
SFP 2.2x6

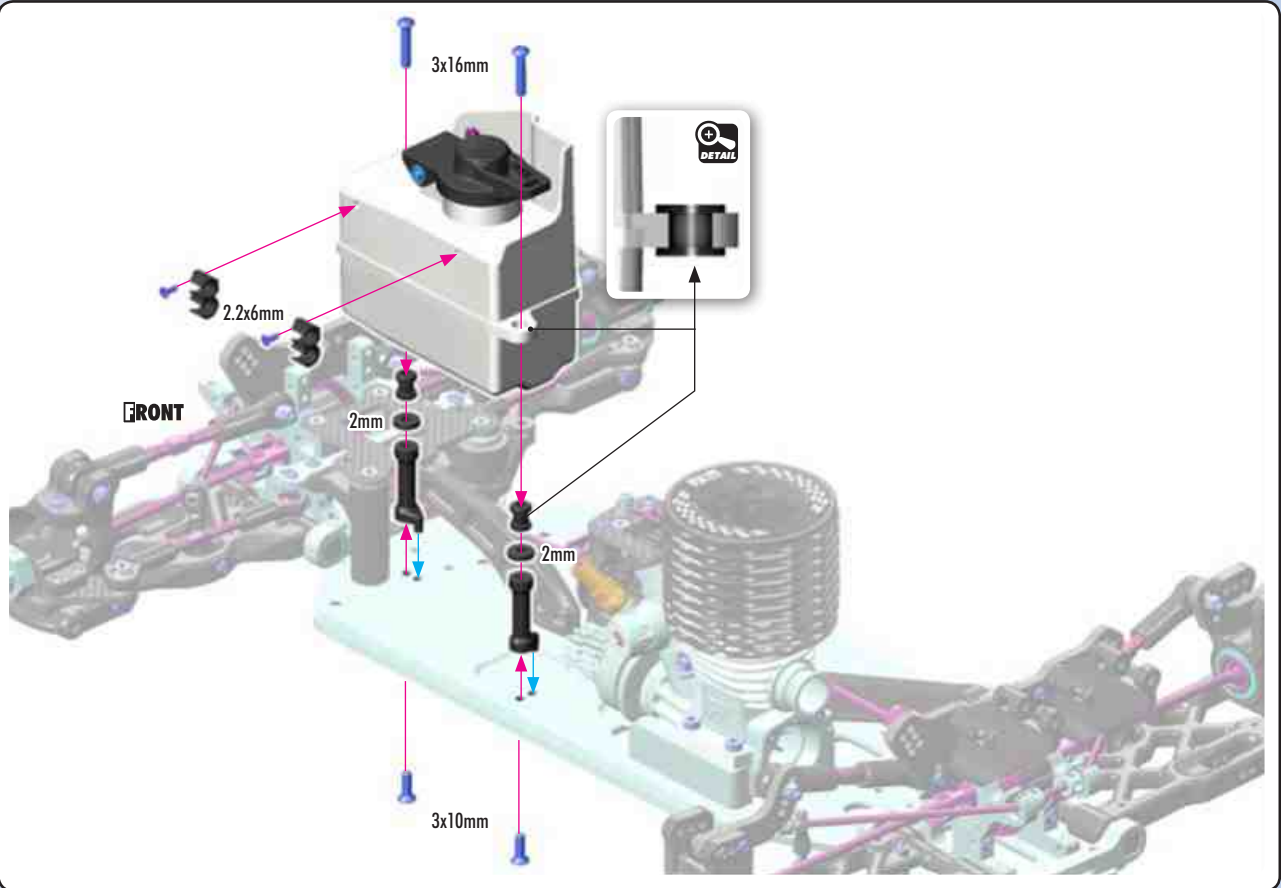

901405
SB M4x5



903410
SFH M4x10

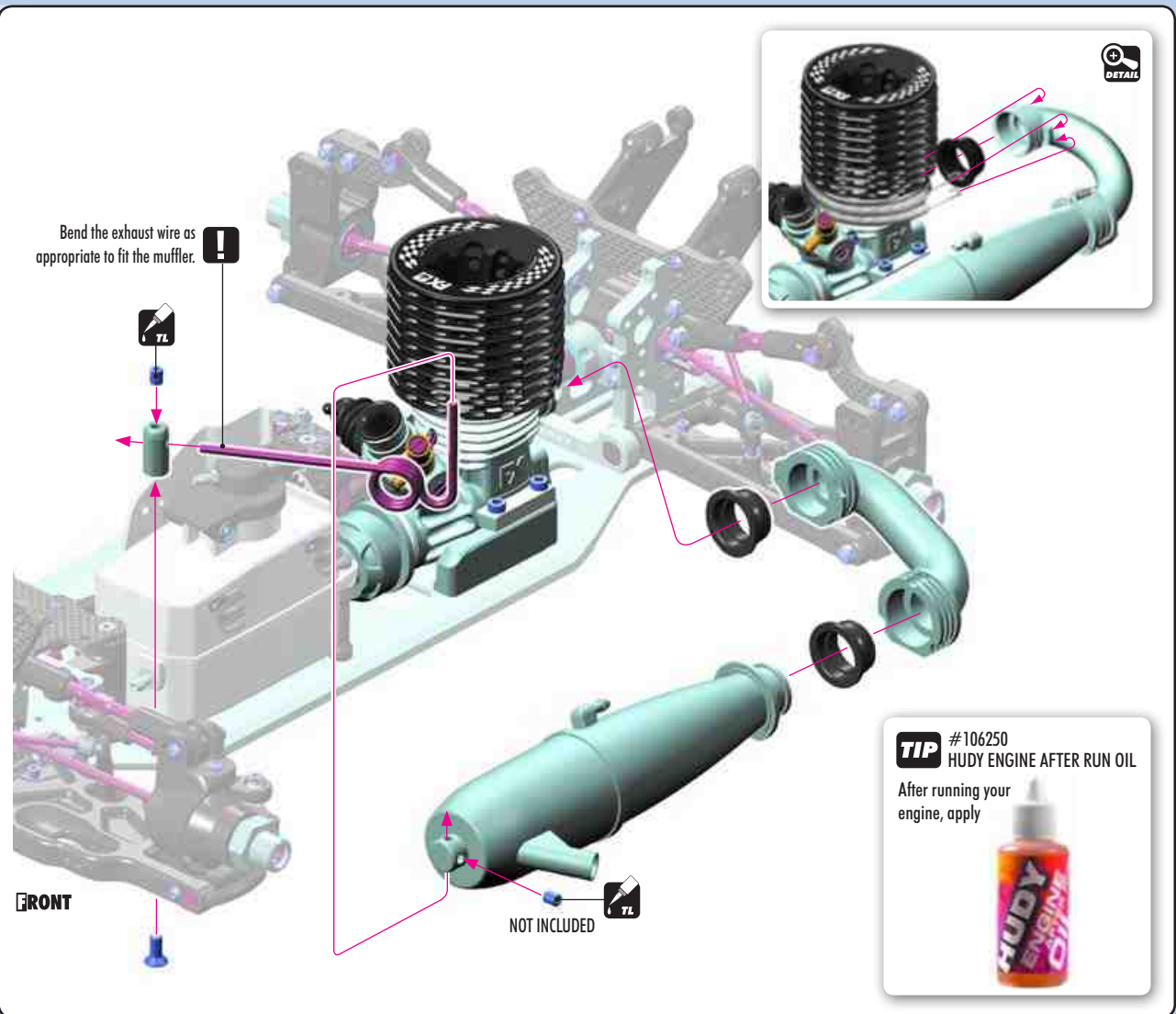

10. RADIO CASE

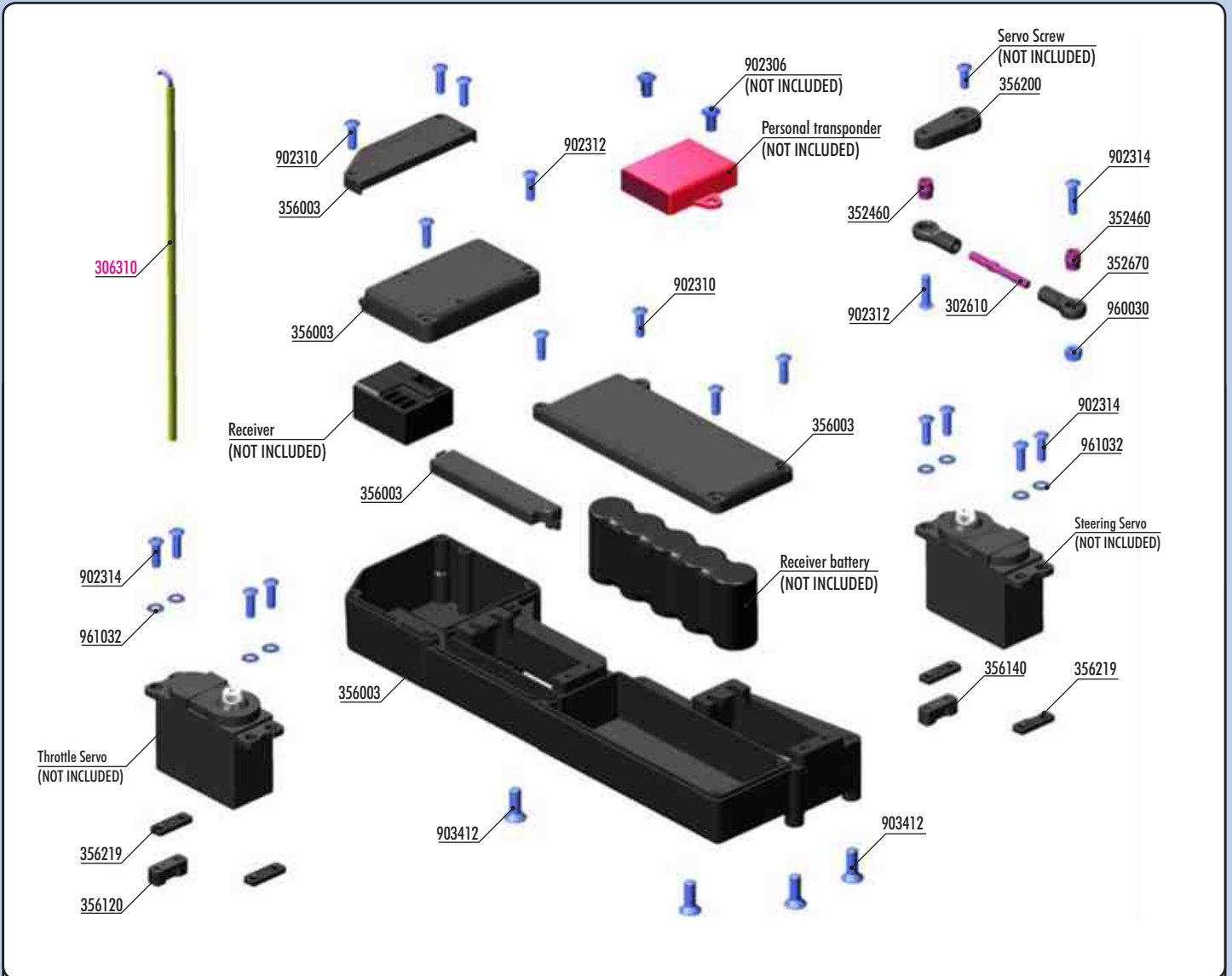

BAG

10

- 302610 ADJ. TURNBUCKLE M3 L/R 39MM - HUDY SPRING STEEL™ (2)
- 352460 PIVOT BALL 5.8 (10)
- 352670 SERVO BALL JOINT 5.8MM (4)
- 356003 COMPOSITE RADIO CASE SET
- 356050 BATTERY CABLE WITH SWITCH (OPTION)
- 356140 COMPOSITE SERVO MOUNT - SMALL (2)
- 356200 BRAKE/THROTTLE ARMS & STEERING SERVO ARMS - SET
- 356219 COMPOSITE SERVO SHIMS 1.0, 1.5 & 2.5MM (2+2+2)
- 389135 CONNECTING CABLE RECEIVER/BATT. PACK (OPTION)

- 902306 HEX SCREW SH M3x6 (10) (OPTION)
- 902310 HEX SCREW SH M3x10 (10)
- 902312 HEX SCREW SH M3x12 (10)
- 902314 HEX SCREW SH M3x14 (10)
- 903412 HEX SCREW SFH M4x12 (10)
- 960030 NUT M3 (10)
- 961032 WASHER S 3.2 (10)

306310 ANTENNA TUBE (2)



902312
SH M3x12

TIP



Install the all pivot balls with Professional Multi Tool (HUDY #183011).

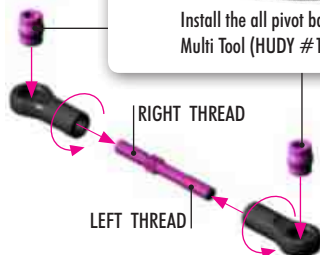

The length of the linkages varies according to the type of servo.



Use appropriate servo arm:

- K - (23T)
- H - (24T)
- F - (25T)

NOTE
ORIENTATION

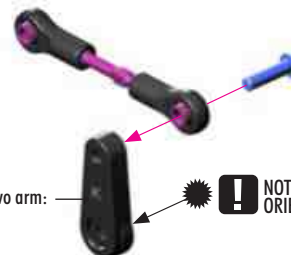

OPTION	CLAMP ALU SERVO HORNS		
#293407	23T	OPTION	
#293408	24T	OPTION	
#293409	25T	OPTION	

OPTION	ALU SERVO HORNS		
#293501	23T	OPTION	
#293502	24T	OPTION	
#293503	25T	OPTION	

10. RADIO CASE



902314
SH M3x14



961032
S 3.2

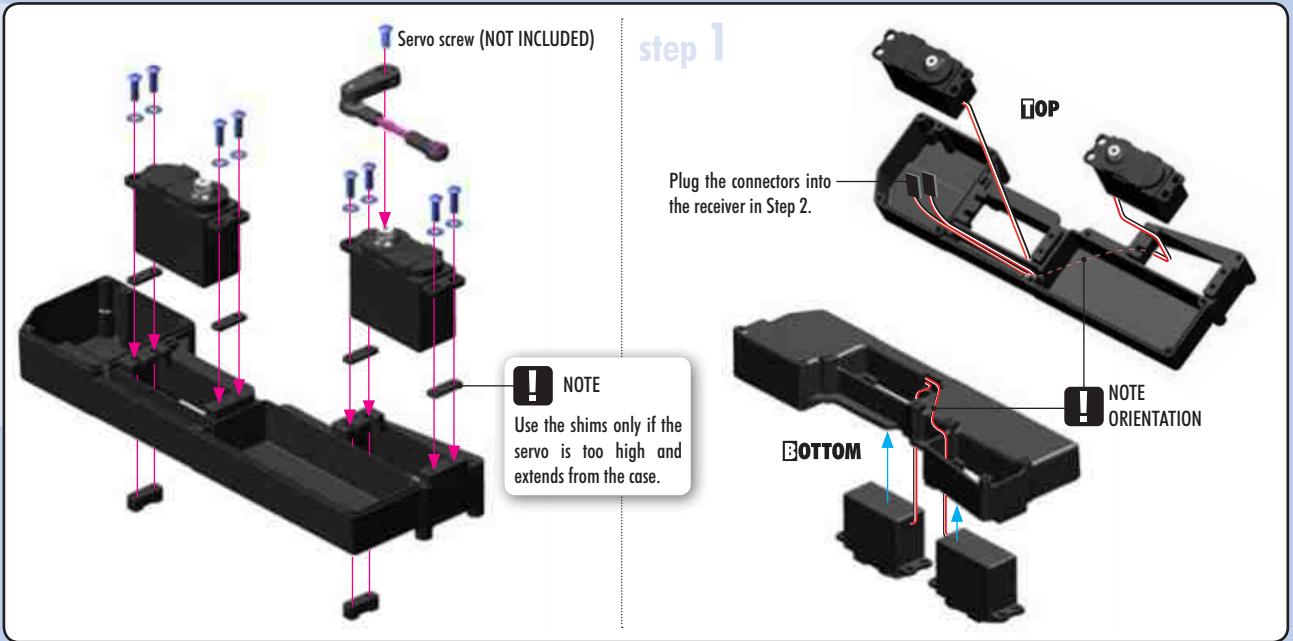

902310
SH M3x10



902312
SH M3x12



907206
SP M2x6

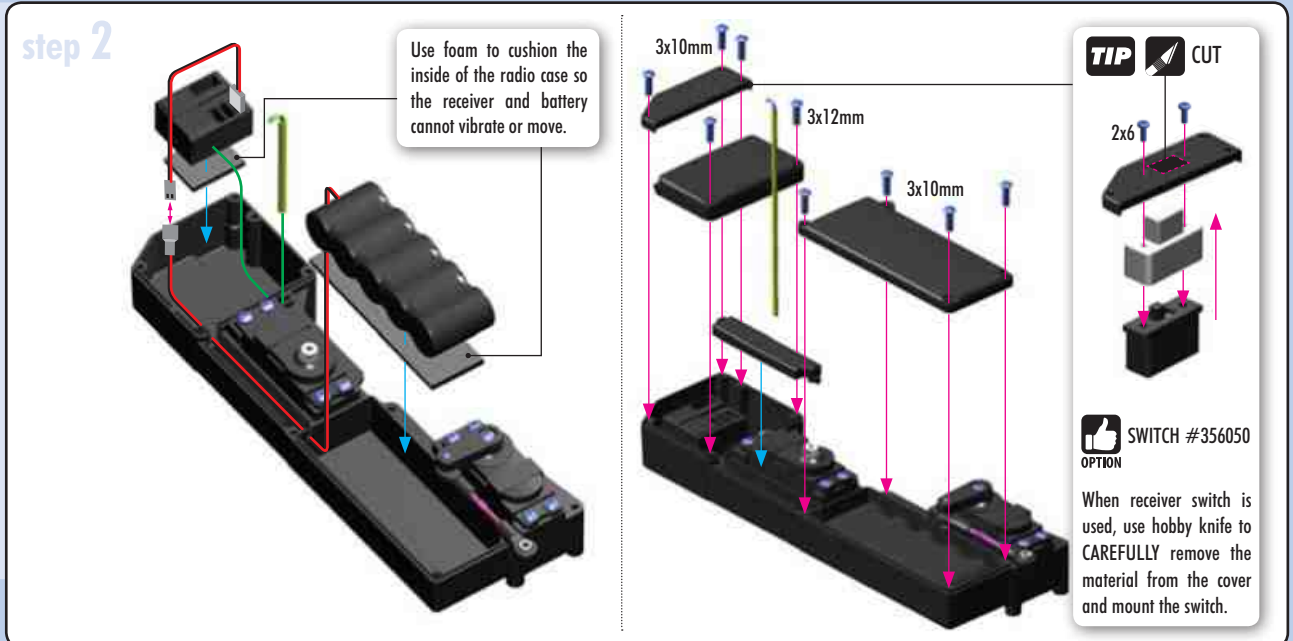

902314
SH M3x14



903412
SFH M4x12



960030
N M3

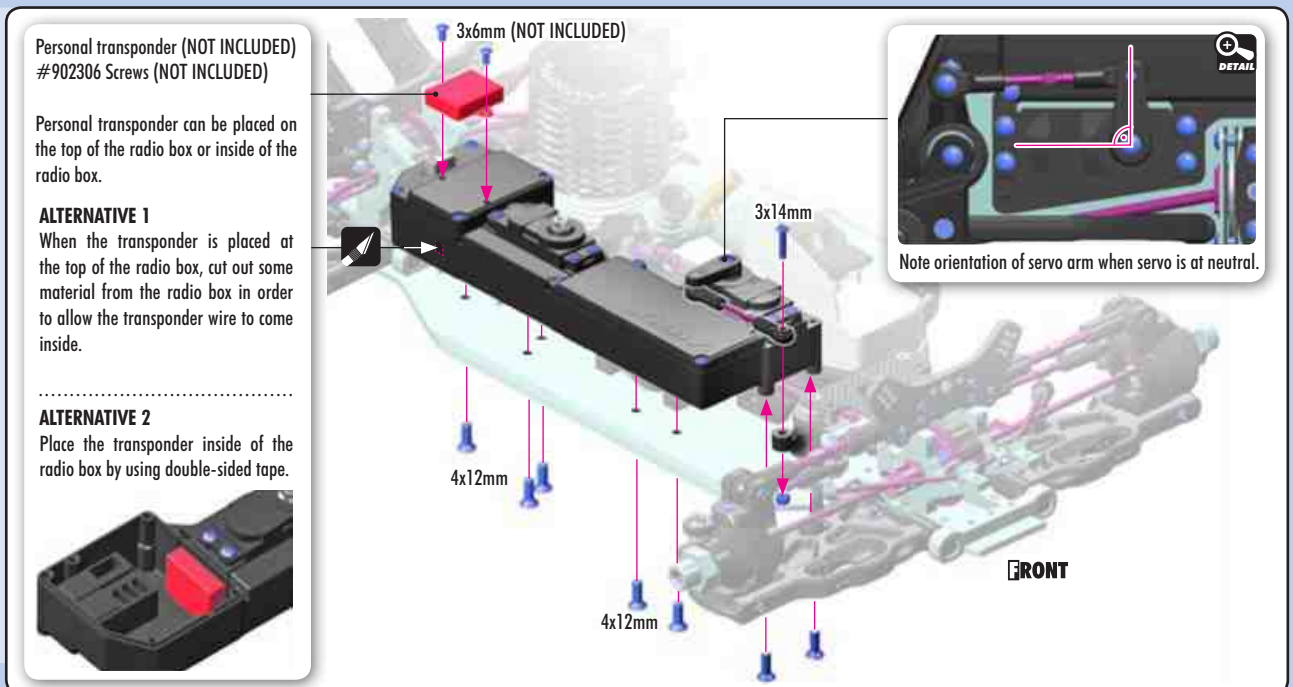

11. SHOCK ABSORBERS

PISTONS

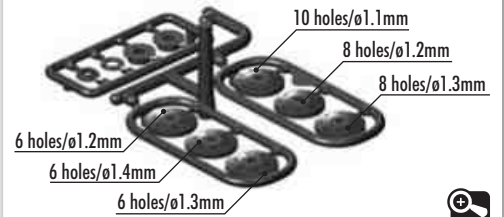

#358196
 XRAY GT SPRING SET C=6.0, 3 DOTS (2)

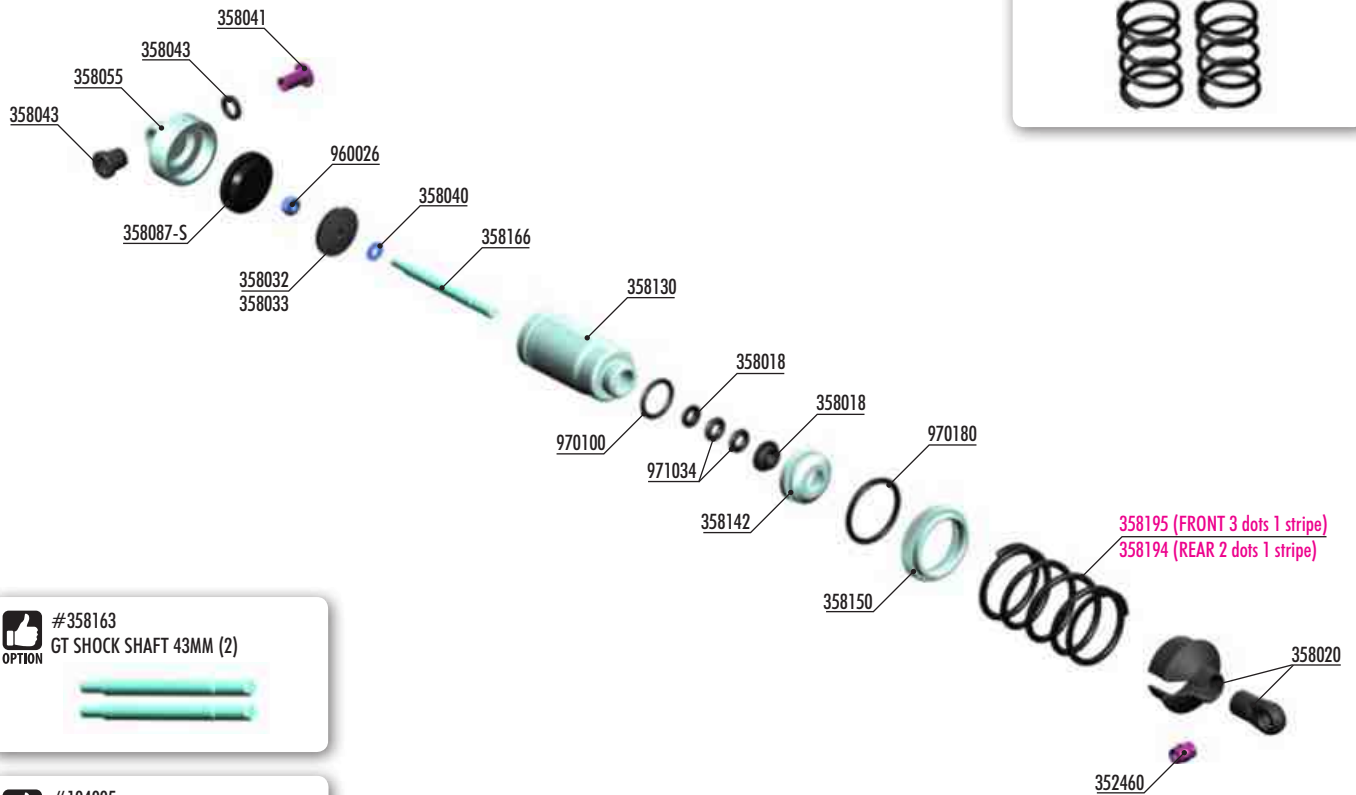

#358163
 GT SHOCK SHAFT 43MM (2)



#104005
 HUDY AIR VAC - VACUUM PUMP
 - 1/8 OFF-ROAD



SHOCK RUBBER MEMBRANE (4)			
#358084-S	BRIBBED	SOFT	OPTION
#358087-S	CELL	SOFT	INCLUDED
#358087-M	CELL	MEDIUM	OPTION

#358027 PISTON 5-HOLE (1.5mm) & 2-HOLE (1.0mm) (4)
#358028 PISTON 6-HOLE (1.3mm) & 2-HOLE (1.1mm) (4)
#308029 PISTON 6-HOLE (1.4mm) & 2-HOLE (1.1mm) (4)
#358030 PISTON 8-HOLE (1.2mm) & 2-HOLE (1.2mm) (4)
#358031 PISTON 8-HOLE (1.3mm) & 2-HOLE (1.2mm) (4)



#358054-K
 ALU SHOCK CAP NUT WITH VENT HOLE - BLACK COATED (2)



BAG

11

- 352460 PIVOT BALL 5.8 - V3 (10)
- 358018 COMPOSITE SET OF SHIMS FOR SHOCKS - (2)
- 358020 COMPOSITE SHOCK PARTS
- 358032 SHOCK PISTON SET 8-HOLE (1.2; 1.3) 10-H. (1.1MM) - DELRIN - V2
- 358033 COMPOSITE SHOCK 6-HOLE PISTON SET (1.2; 1.3; 1.4MM) - DELRIN - V2
- 358040 HARDENED SHOCK SHIMS (4)
- 358041 STEEL SHOCK BUSHING (2)
- 358043 COMPOSITE SHOCK BUSHING & SHIM (2+2)
- 358055 ALU SHOCK CAP NUT - BLACK COATED (2)
- 358087-S SHOCK RUBBER MEMBRANE CELL - SOFT (4)
- 358130 GT ALU SHOCK BODY - V2 (2)
- 358142 ALU SHOCK BODY NUT FOR SHOCK BOOT (2)

- 358150 ALU SHOCK BODY ADJ. NUT (2)
- 358166 GT SHOCK SHAFT 46MM (2)
- 960026 NUT M2.5 - SHORT (10)
- 970100 O-RING 10 x 1.5 (10)
- 970180 O-RING 18 x 1.8 (10)
- 971034 SILICONE O-RING 3.5x2 (10)

- 358194** XRAY GT PROGRESSIVE SPRING SET C=4.1-4.7, 2-DOTS WITH STRIPE (2)
- 358195** XRAY GT PROGRESSIVE SPRING SET C=5.2-5.8, 3-DOTS WITH STRIPE (2)

11. SHOCK ABSORBERS



358040
S 2.5x6x0.5



960026
N M2.5

4x

6 holes
ø1.2mm pistons



#358163
GT SHOCK SHAFT 43MM (2)



Install the piston with Professional Multi Tool (HUDY #183011).



INCORRECT



DO NOT OVERTIGHTEN

The self-locking nut is overtightened, causing distortion of the piston. This will negatively affect the free movement of the piston in the shock body.

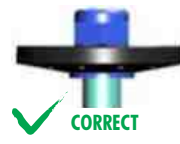

CORRECT



TIGHTEN GENTLY

The self-locking nut is gently tightened. The piston remains undistorted and fits inside the shock body perfectly, ensuring smooth movement of the piston.

SET-UP BOOK

SHOCK DAMPING
SHOCK PISTONS



970100
O 10x1.5



971034
O 3.4x2

4x

There are two different thickness shims, use them as shown. Use the same procedure when building both front and rear shocks.

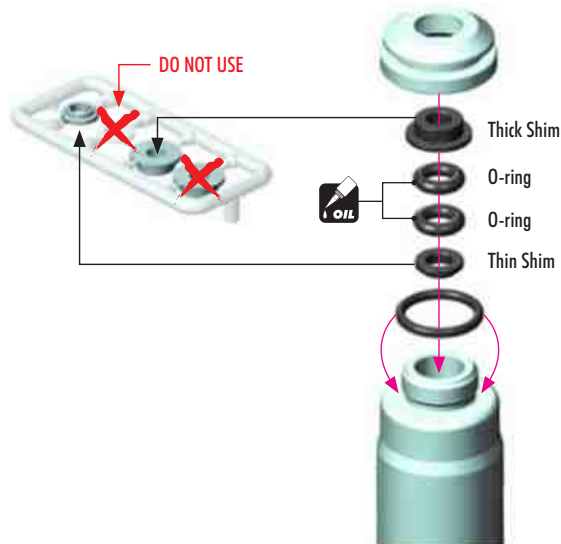

4x

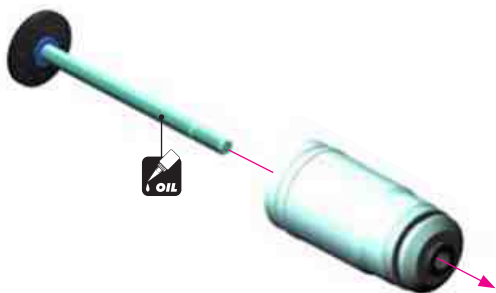

EXTREMELY IMPORTANT

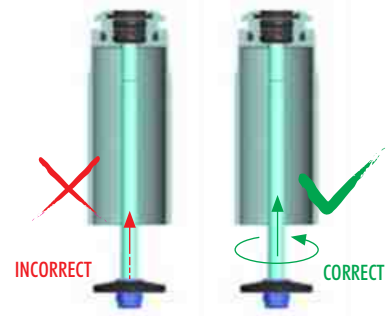

INCORRECT

CORRECT

Do not push the shock rod straight through the lower shock body assembly; O-ring damage may result.

Twist the shock rod through the lower shock body assembly.

11. SHOCK ABSORBERS



970180
Ø 18x1.8

4x

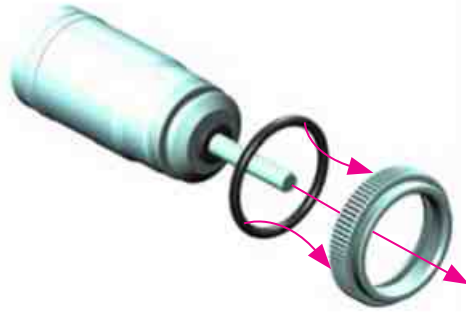

2x FRONT SHOCKS

2x REAR SHOCKS

Professional Multi Tool
(HUDY #183011).

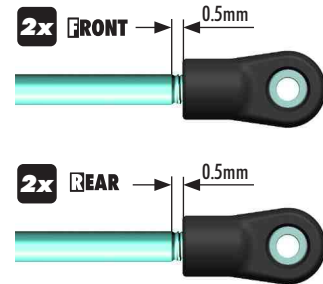
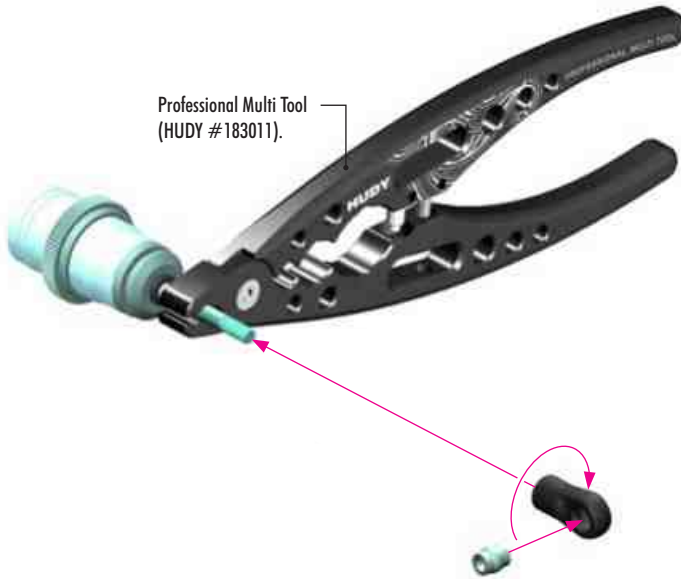

DEFAULT SHOCK REBOUND SETTING 0% (LOW REBOUND)

Follow the steps below to set the shock rebound to the default setting of 0%.

4x SHOCK
Oil 800cSt

SET-UP
BOOK
SHOCK OIL

- Extend the shock shaft completely. Fill the shock body with the shock oil. For the shocks use 800cSt oil.
- Move the shock shaft up and down a few times to release the air bubbles trapped beneath the piston.
- Orient the filled shock vertically for several minutes with the shock shaft fully extended. The remaining air bubbles will release.
- Install the shock membrane into the groove in the upper shock cap.
- Gently place the shock cap assembly onto the filled shock body. Excess oil will spill from the shock. Screw the shock cap onto the body by only a few turns.
- Gently push the shock shaft completely into the shock body. Excess oil will flow through the hole in the shock cap.
- Keep the shock shaft pushed in the shock body and tighten the shock cap completely. The rebound will be at approximately 0%.

11. SHOCK ABSORBERS



971034
0.34x2

4x

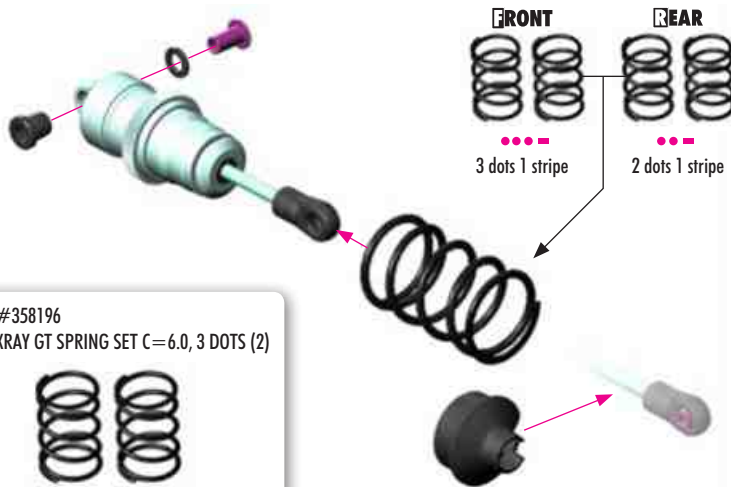

#358196
XRAY GT SPRING SET C=6.0, 3 DOTS (2)
OPTION

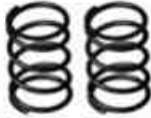

SET-UP BOOK

SPRING RATE SHOCK
PRELOAD
RIDE HEIGHT



SHOCK PRELOAD

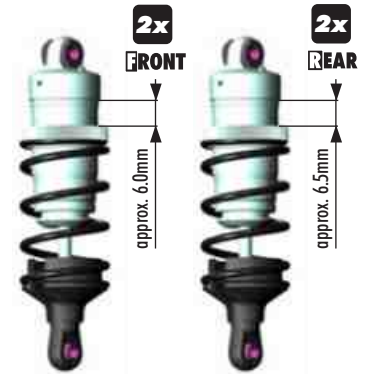

TIP ALTERNATE SHOCK REBOUND SETTING (50% AND 100%)

The default shock rebound setting is 0% (as described on page 40). Alternatively, you may set the shock rebound setting to 50% or 100% as described below. Remove the shock springs before performing shock rebound adjustment.

SETTING THE SHOCK REBOUND TO 50% (MEDIUM REBOUND)

REMOVE SHOCK CAP



1 Extend the shock shaft completely and remove the shock cap.



2 Fill the shock body with shock oil up to the top. Make sure to use same viscosity shock oil as is in the shock.



3 Orient the filled shock vertically for several minutes with the shock shaft fully extended. The remaining air bubbles will release.

HALF TIGHTEN 50%



4 Gently place the shock cap assembly onto the filled shock body. Excess oil will spill from the shock.



5 Push the shock shaft 50% into the shock body. Excess oil will bleed through the hole in the shock cap.

TIGHTEN FULLY 100%

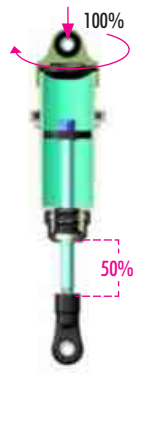

6 Keep the shock shaft pushed 50% into the shock body and tighten the shock cap completely. The rebound will be at approximately 50%.

SETTING THE SHOCK REBOUND TO 100% (HIGH REBOUND)

REMOVE SHOCK CAP



1 Extend the shock shaft completely and remove the shock cap.



2 Fill the shock body with shock oil up to the top. Make sure to use same viscosity shock oil as is in the shock.



3 Orient the filled shock vertically for several minutes with the shock shaft fully extended. The remaining air bubbles will release.

TIGHTEN FULLY 100%



4 Gently place the shock cap assembly onto the filled shock body. Keep the shock shaft extended 100% from the shock body and tighten the shock cap completely. The rebound will be at approximately 100%.

12. FINAL ASSEMBLY

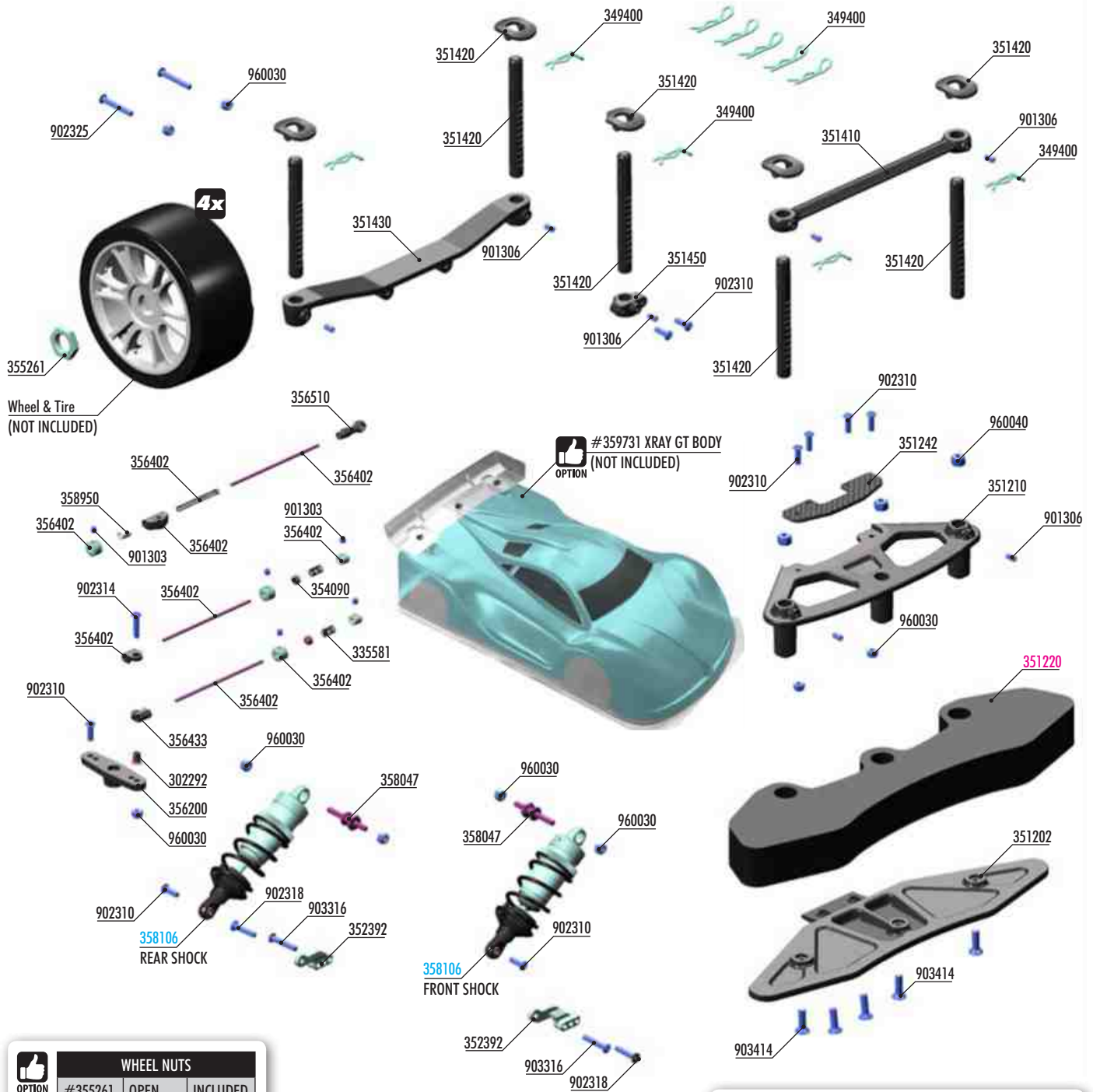

WHEEL NUTS			
OPTION	#355261	OPEN	INCLUDED
	#293560	COVERED	OPTION
	#355265	COVERED	OPTION

OPTION #351222 GT FOAM BUMPER - LIGHT
 OPTION #351233 GT COMPOSITE DIFFUSOR + #351235 ADAPTER
 #351460 GT HORIZONTAL BODY MOUNTING - SET



- 302292 STEEL STEERING BUSHING LONG (4)
- 335581 SPRING C=7.8 FOR GEAR BOX - MEDIUM - SILVER (2)
- 349400 BODY CLIP (10)
- 351202 COMPOSITE FRONT BUMPER - NARROW
- 351210 GT COMPOSITE FRONT UPPER BUMPER
- 351242 GT GRAPHITE PLATE FOR FRONT UPPER BUMPER
- 351410 GT COMPOSITE FRONT HOLDER FOR BODY POSTS
- 351420 GT COMPOSITE BODY POSTS (2)
- 351430 GT COMPOSITE REAR HOLDER FOR BODY POSTS
- 351450 GT COMPOSITE CENTER BODY POST HOLDER
- 352392 GT ALU SHOCK PLATE - SWISS 7075 T6 (L+R)
- 354090 BALL-SHAPED BRAKE BUSHING (2)
- 355261 WHEEL NUT - RIBBED - HARD COATED (2)
- 356200 BRAKE/THROTTLE ARMS & SERVO ARMS - SET
- 356402 X88 BRAKE/THROTTLE SYSTEM - SET
- 356433 GT COMPOSITE BRAKE WIRE HOLDER (2)
- 356510 CLOSED BALL JOINT 3.9 (4)
- 358047 STEEL SCREW SHOCK PIVOT BALL WITH HEX (2)
- 358950 SILICONE TUBING 1M (2.4 x 5.5MM)
- 901303 HEX SCREW SB M3x3 (10)
- 901306 HEX SCREW SB M3x6 (10)
- 902310 HEX SCREW SH M3x10 (10)
- 902314 HEX SCREW SH M3x14 (10)
- 902318 HEX SCREW SH M3x18 (10)
- 902325 HEX SCREW SH M3x25 (10)
- 903316 HEX SCREW SFH M3x16 (10)
- 903414 HEX SCREW SFH M4x14 (10)
- 960030 NUT M3 (10)
- 960040 NUT M4 (10)
- 358106 GT SHOCK ABSORBER - V2 (2)
- 351220 GT FOAM BUMPER - V2

12. FINAL ASSEMBLY

2x **FRONT**

902310 SH M3x10

902318 SH M3x18

903316 SFH M3x16

960030 N M3

SHORTER → LONGER

NOTE ORIENTATION !

NOTE ORIENTATION !

3x16mm

3x18mm

3x10mm

INITIAL SETTING

INITIAL SETTING

ALU SHOCK PLATE

NOTE ORIENTATION !

RL-FR | RR-FL
(rear left or front right) | (rear right or front left)

INITIAL SETTING

2 1

2x **REAR**

902310 SH M3x10

902318 SH M3x18

903316 SFH M3x16

960030 N M3

SHORTER → LONGER

NOTE ORIENTATION !

NOTE ORIENTATION !

3x16mm

3x18mm

3x10mm

INITIAL SETTING

INITIAL SETTING

ALU SHOCK PLATE

NOTE ORIENTATION !

RL-FR | RR-FL
(rear left or front right) | (rear right or front left)

INITIAL SETTING

2 1

901303 SB M3x3

902310 SH M3x10

902314 SH M3x14

960030 N M3

Thread brake rods into plastic pivots until flush with outer end.

Brake rod

Brake rod

Throttle rod

3x14mm

3x10mm

SILICONE TUBING 9mm

Cut off remaining material.

Use servo horn to match your servo
K - (23T)
H - (24T)
F - (25T)

OPTION HUDY

CLAMP ALU SERVO HORNS		
#293444	23T	OPTION
#293445	24T	OPTION
#293446	25T	OPTION
#293447	23T	OPTION
#293448	24T	OPTION
#293449	25T	OPTION

OPTION HUDY

ALU SERVO HORNS		
#293504	23T	OPTION
#293505	24T	OPTION
#293506	25T	OPTION
#293507	23T	OPTION
#293508	24T	OPTION
#293509	25T	OPTION

12. FINAL ASSEMBLY

901303
SB M3x3

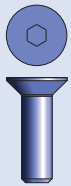
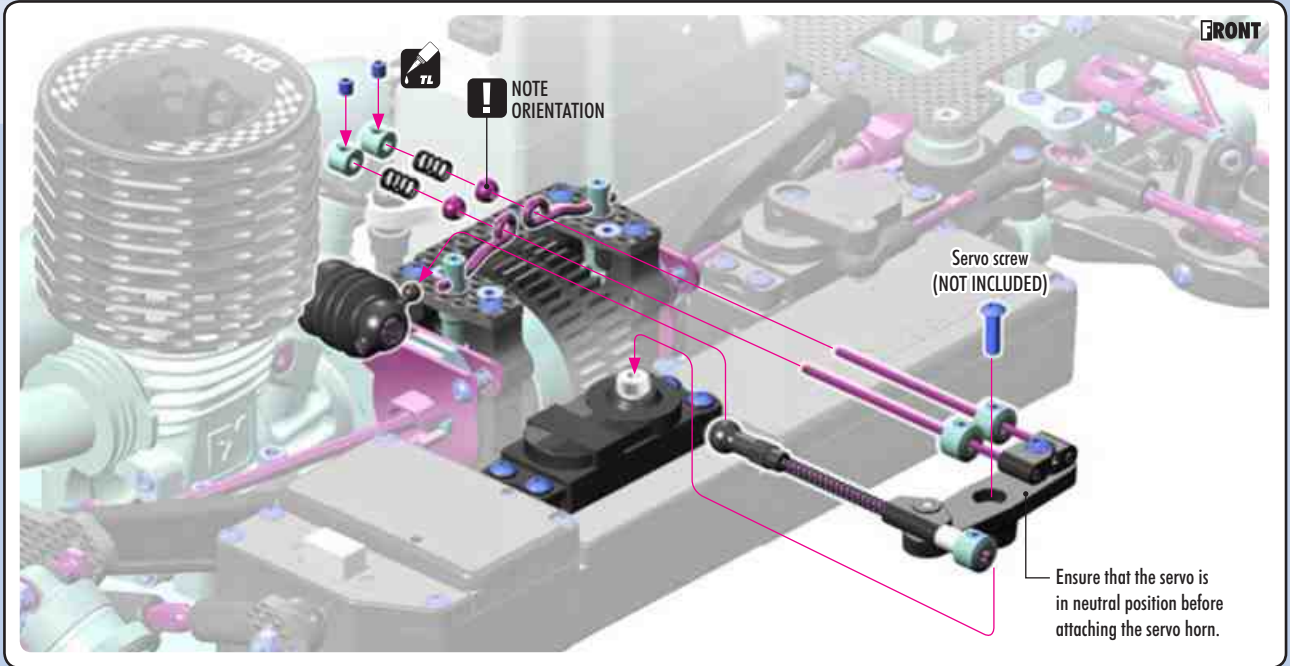

903414
SFH M4x14



960040
N M4

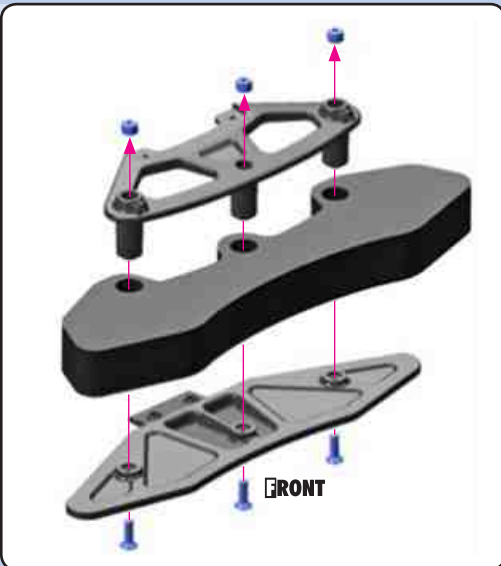

902310
SH M3x10



960030
N M3

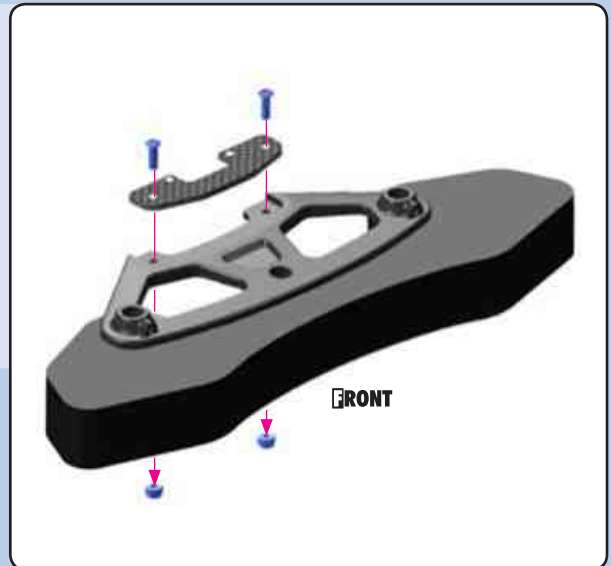

901306
SB M3x6



902310
SH M3x10



903414
SFH M4x14

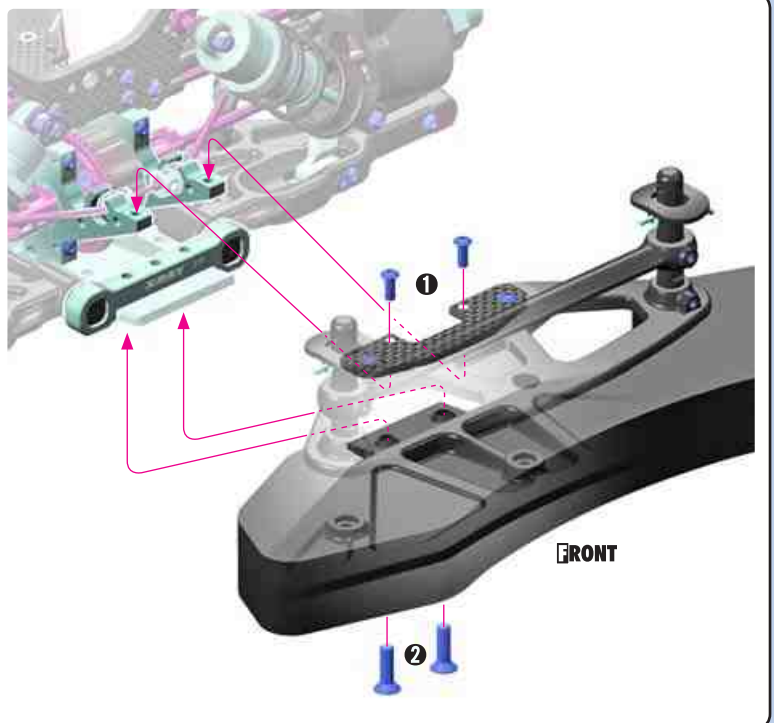
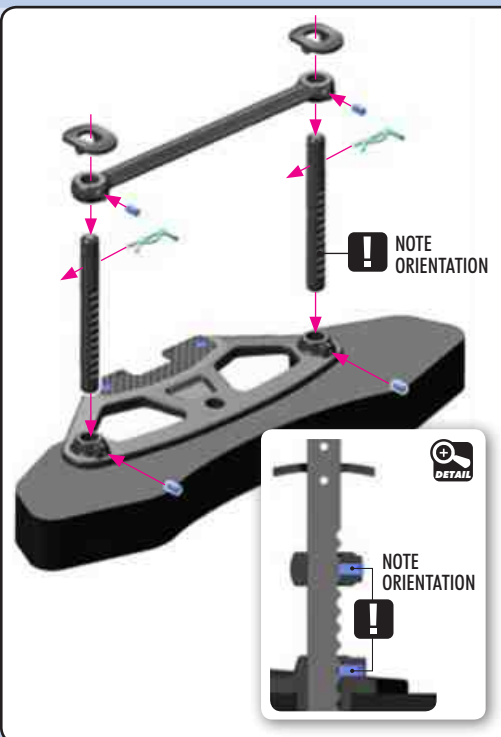

12. FINAL ASSEMBLY



901306
SB M3x6



902310
SH M3x10

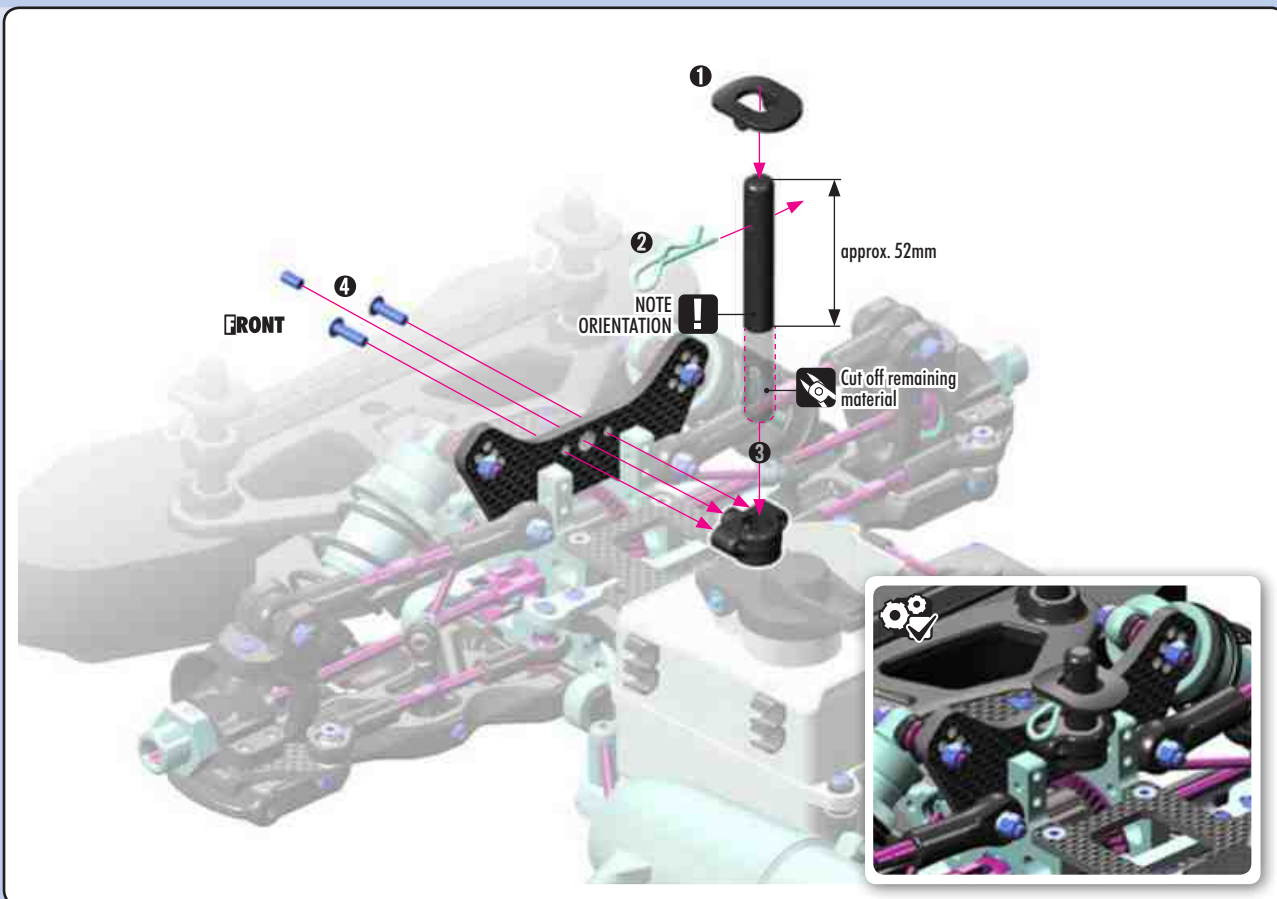

901306
SB M3x6



902325
SH M3x25



960030
N M3

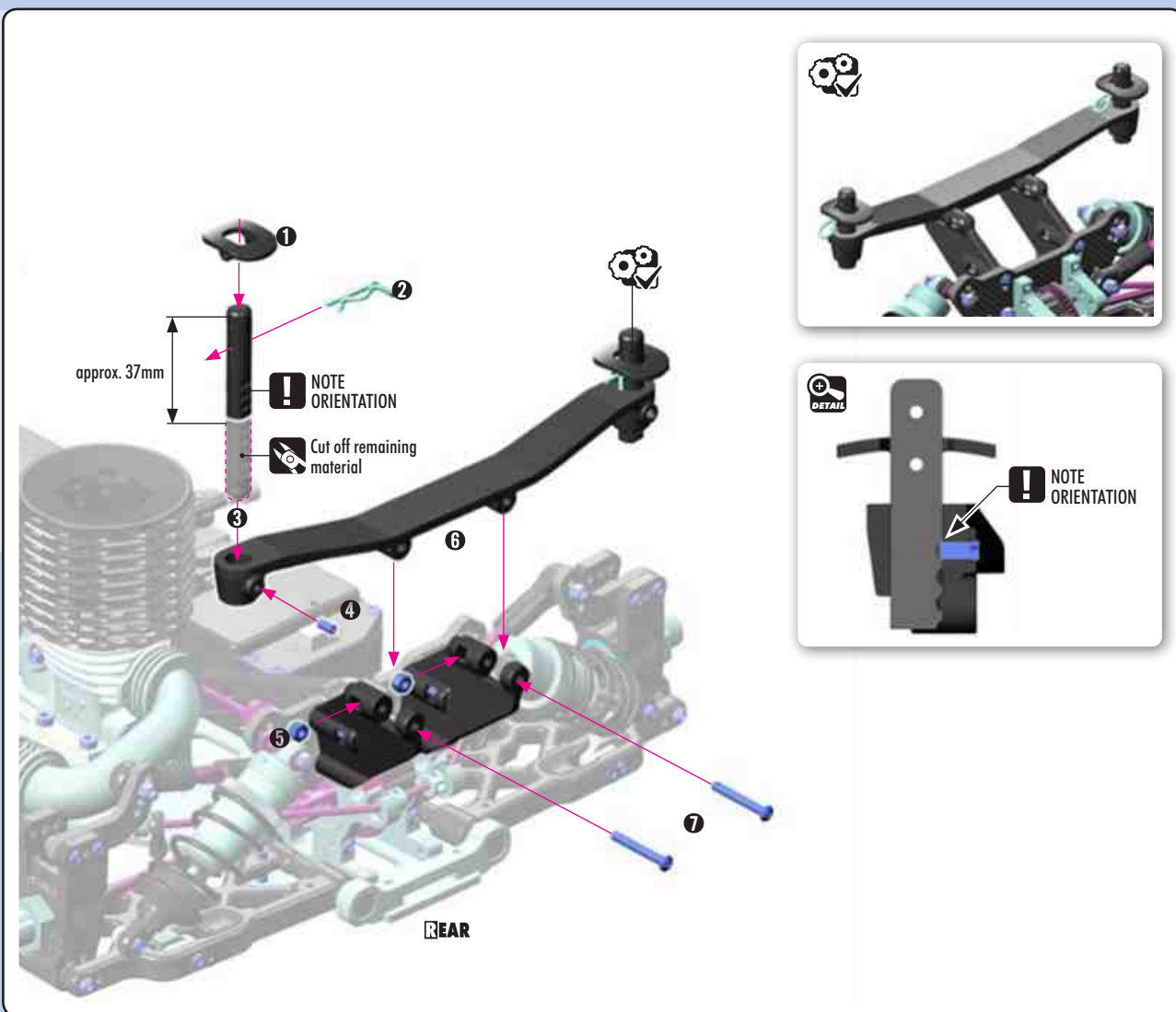

12. FINAL ASSEMBLY

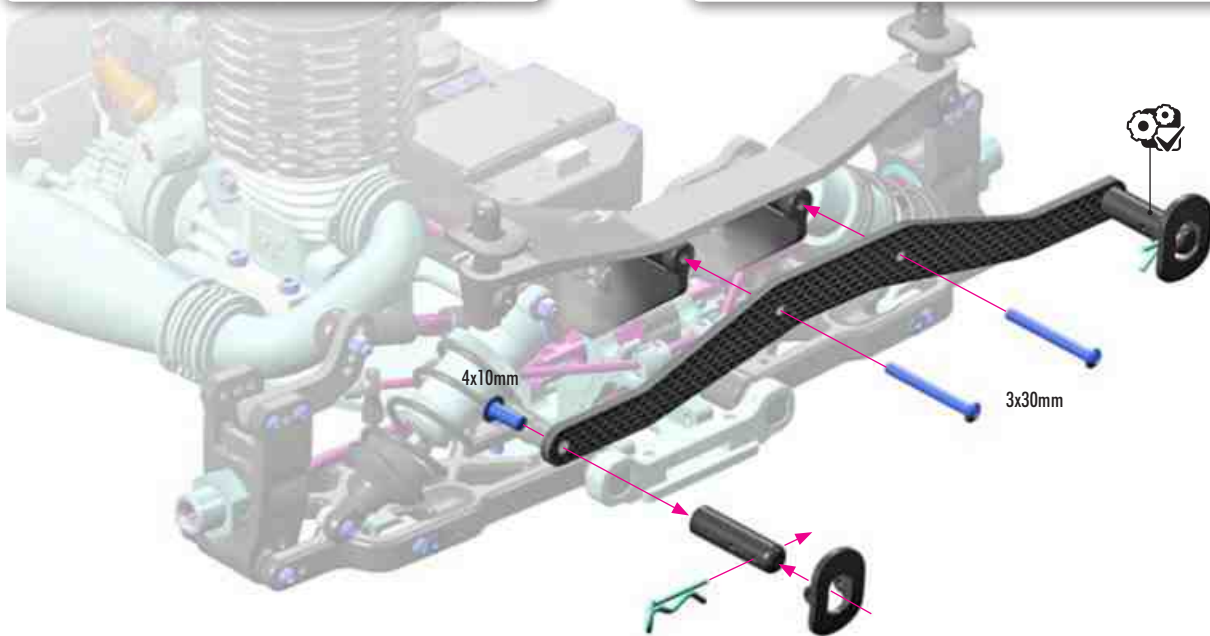

4x

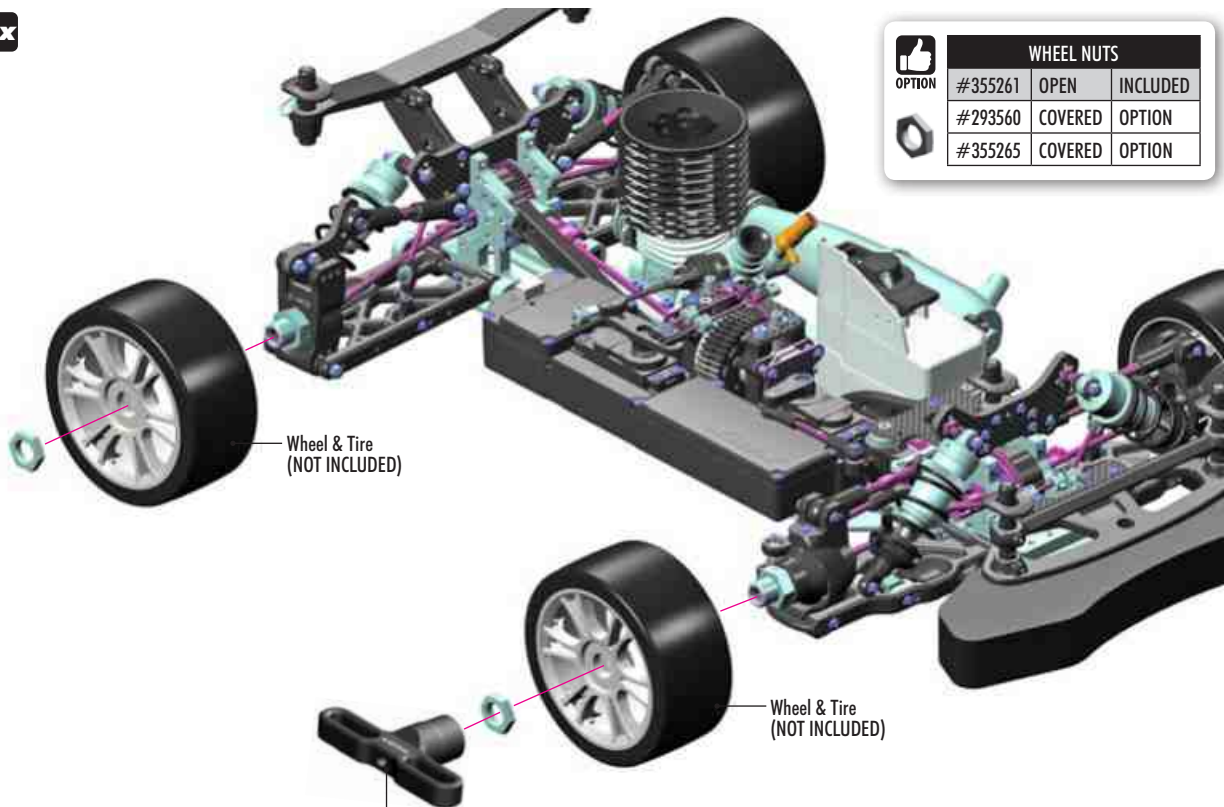

WHEEL NUTS			
OPTION	#355261	OPEN	INCLUDED
	#293560	COVERED	OPTION
	#355265	COVERED	OPTION

TIP To tighten the screw you can also use the #107570 HUDY 17mm Wheel Nut Tool.

Cut the silicone tube depending on engine and muffler. Use the plastic clips to hold the tubes together.

SILICONE TUBE MARKED AS
BLUE = FROM FUEL TANK TO CARBURETOR

SILICONE TUBE MARKED AS
RED = FROM MUFFLER TO FUEL TANK (TOP)

! Keep fuel line away from clutchbell and flywheel.

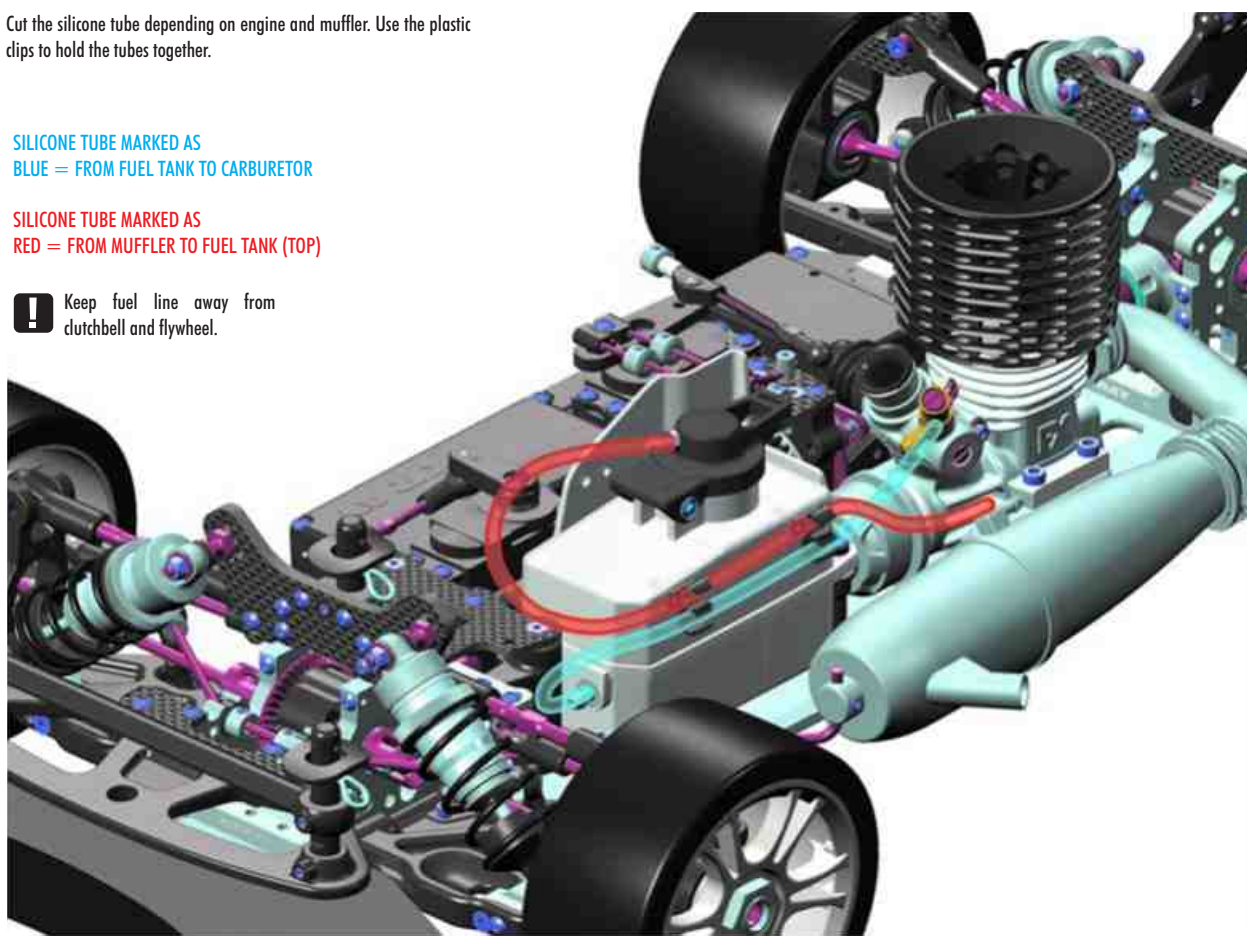

! #359731 GTX BODY (NOT INCLUDED)
OPTION

- 1 Before cutting and making holes on the body, put the unpainted body on the chassis to confirm the mounting position and location for holes and cutouts.
- 2 Before painting, wash the inside of the body with mild detergent, and then rinse and dry thoroughly.
- 3 Mask all windows.
- 4 Apply paint masks as appropriate.
- 5 Paint the body using paints formulated for polycarbonate bodies.
- 6 When the paint is dry, remove the masking.
- 7 Carefully cut out the body using appropriate scissors or cutting tools.
- 8 When you have finished cutting, peel off the external protective films.



TIP To reinforce the body or to fix broken body use #106281 HUDY BODY FIX.

WING SHIMS			
OPTION	#353565	COMPOSITE	INCLUDED
	#293561	ALU	OPTION
	#293561-K	ALU	OPTION
	#293561-O	ALU	OPTION
	#353561	ALU	OPTION

Use Body Reamer (HUDY #107602) for all holes.

TIP

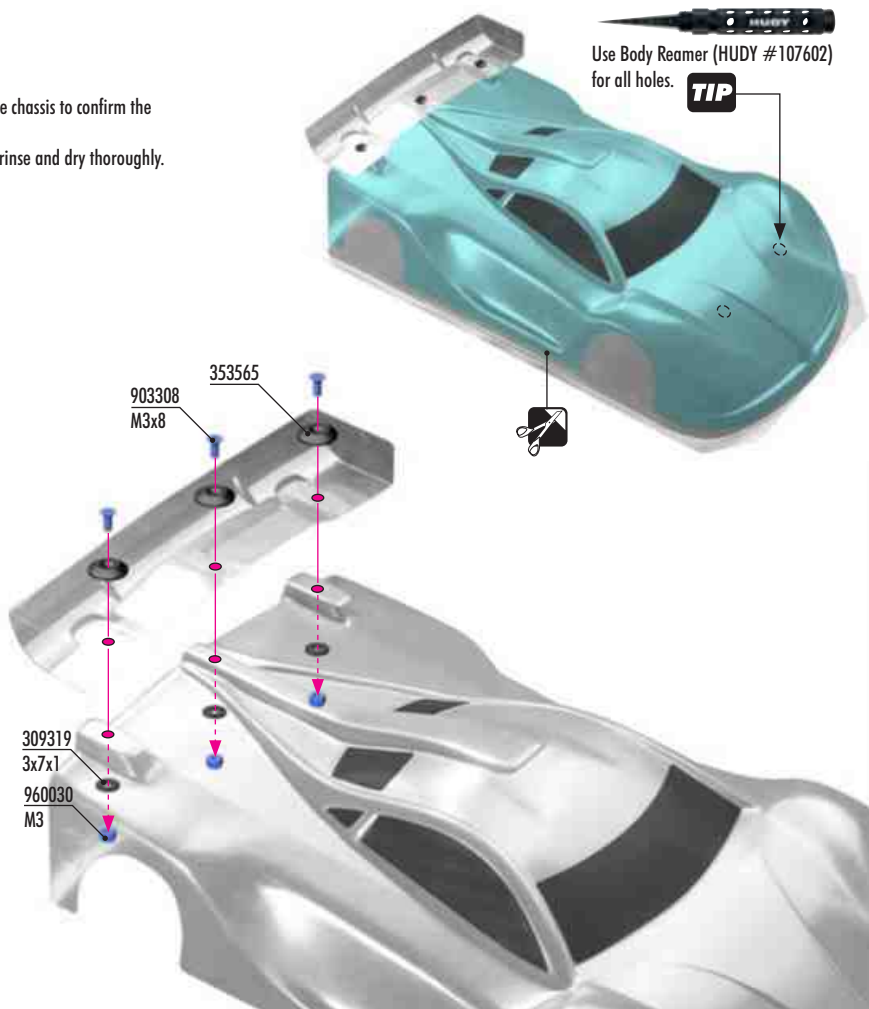

MAINTENANCE

ENGINE OPERATION

PREPARING TO OPERATE THE ENGINE

- Never modify the engine or muffler.
- Confirm the position of needle and idling before running. Be sure to run a new engine smoothly.
- Make sure the air filter is clean and oiled.
- Never run your engine without an air filter. Your engine can be seriously damaged if dirt and debris get inside the engine.

STARTING AND RUNNING THE ENGINE

Be sure to observe the following starting process. Failure to do so may cause the model car to start suddenly, which may lead to damage or unexpected accidents.

1. Make sure the transmitter and receiver batteries are fully charged.
2. Make sure that your transmitter and receiver are both on the same frequency. If you have a transmitter with multiple model memory, make sure you have selected the proper profile for your car.
3. Put the car on the starter box and keep the tires from touching the ground.
4. Turn on the transmitter.
5. Turn on the receiver in the car.
6. Make sure the steering servo and engine servos work normally and adjust them correctly.
7. Put fuel in the fuel tank, and close the cap securely.
8. Apply the glow igniter to the engine glowplug.
9. Push the model car onto the starter box to start the engine. (If the engine is new, follow the instruction manual and be sure to break in the new engine properly).
10. When the engine has started, remove the glow igniter.
11. Follow your engine break-in procedure and tune the engine as appropriate.

STOPPING THE ENGINE

Before you stop the engine, try to make sure the engine is at idle first. There are several ways to stop the engine:

- Use a rag to cover the exhaust tip. Be careful! The exhaust is extremely hot so use a thick rag and gloves.
- Pinch the fuel tubing to stop the flow of fuel to the carb. Be careful, this can make the motor run lean which can damage the motor.
- Put your hand over the air filter, or squeeze the air filter element to block the airflow.
- Press an object (such as a screwdriver handle or shoe) against the rotating flywheel to stop its rotation. Be very careful, and do not stick your hand or fingers near the rotating flywheel.

FINISHING OPERATIONS

1. Stop the engine.
2. Turn off the receiver in the car
3. Turn off the transmitter.

MAINTENANCE AFTER RUNNING

Take proper care of your car after running to keep it performing well, and take notice of any damage and wear.

1. Do not leave fuel in the tank.
2. Go outside to drain any residual fuel from the exhaust pipe.
3. Clean the car and remove all sand, mud, and other debris.
4. Use after-run oil in your engine after you have finished running for the day.

SHOCK MAINTENANCE

The most important maintenance task for keeping consistent shock performance is refilling and bleeding them correctly. If built correctly, it will not be necessary to re-build them often. Replacing warped/hard rubber bladders and o-rings, scarred piston rods, or shaved/split/loose composite upper and lower ball joints are also important.

- For club racing, it is recommended to check the shocks for air inside before each race and only re-fill and bleed them if necessary. Before each race day, make sure you take the spring off of each shock, hold it up to your ear, and quickly compress the shock rod fully into the body while listening for any air making a "whistling" or "squishy" sound as it passes through the piston holes. If you hear any air, refill and bleed your shocks. For high-competition racing, it is recommended that the shocks be re-filled and bled before a large event.
- If building or pairing new shocks, always make sure they are the same length using a shock length measuring tool and adjust the lower ball joints as needed.
- If installing new rubber bladders, carefully trim the thin excess rubber from the edges of their lips. Curved body scissors work the best.
- Regularly inspect the amount of dirt on the felt protector in the shocks (if present) and regularly replace with a new one.
- During regular shock operation, oil naturally gets on the shock shaft and drop-by-drop slightly gets out of the shock body. Shocks should be inspected regularly after each race, and oil replaced as required.

BEARING MAINTENANCE

Ball-bearings in an off-road car or truggy must be properly maintained for smooth operation and long lifespan.

Typically, the ball-bearings included in new cars are greased for highest lifespan and as such the drivetrain may not seem to be as free as with lightly-oiled ball-bearings. However, when the car is run the ball-bearings will become more free and the drivetrain will become very efficient.

There are several types of bearings discussed here: bearings which already come greased from the factory, bearings which must be lubricated using the HUDY Bearing Grease, and then there are also bearings in the steering system which need to be lubricated with HUDY Bearing Oil.

The following procedures are recommended to clean all of the bearings in your off-road car or truggy. For high-competition racing, we recommended doing this every 3-4 weeks, or before a major race.

1. Remove the seals on both sides of the bearing (if present). If the seals bend a little and you can see a kink, carefully flatten the kink out by hand.
2. Spray the seals with motor cleaner and blow dry with compressed air.
3. Spray the bearing on both sides with motor cleaner.
4. Spin the bearing while it is still wet to dislodge any particles with the cleaner.
5. Spray the bearing on both sides again.
6. Blow both sides of the bearing dry with compressed air to make sure particles come out.
7. Hold the inner part of the bearing with my left thumb/forefinger and spin it to make sure it spins free without any abnormal vibrations or sounds.
8. Place one drop of bearing oil into each side of the bearing.
9. Replace both seals at the same time by lining them up on each side of the bearing and lightly pressing them in all the way around the bearings circumference with your thumb and forefinger. Do not press too hard or use any type of tool, such as a wrench tip, to push the blue seals in as they will push in too far, bend and cause drag.

If you spin test the bearing after you have re-oiled and sealed it, it will not spin freely for an extended period of time. The lightest of oils may allow it to spin for 1-2 seconds. This is normal and once you have mounted the bearings in the car again, the drive train will spin freely.

Make sure you use a motor cleaner that does not leave a residue after it dries as this may cause drag and wear in the bearings.

HUDY #106230

CLUTCH BEARINGS

To prolong the lifespan of the clutch bearings, they must be regularly cleaned and lubricated (preferably after each run) using a high-quality grease such as HUDY Bearing Grease. However, after some time the clutch bearings must be replaced with new ones.

RECOMMENDED PRODUCTS

- Use HUDY Bearing Grease to regularly lubricate grease-bearing ball-bearings.
- Use HUDY Bearing Oil to lubricate the bearings of the steering system.
- Use HUDY Bearing Grease to regularly lubricate the clutch bearings.

HUDY
#106213



HUDY
#106220



HUDY
#106222



HUDY
#106221



SUSPENSION & DRIVETRAIN MAINTENANCE

- Check suspension for free movement during building and operation, and especially after running and if you have crashed the car. If the suspension does not move freely, use the appropriate HUDY Arm Reamer to clean and resize the holes of the suspension arms.
- Regularly check the drive shaft pins (both side and center) and if they show any wear must be immediately replaced by new pins. If the car is run with worn pins, excessive wear on the diff outdrives will result. The 106000 HUDY Drive Pin Replacement Tool (for 3mm Pins) is a compact, rugged multi-use tool set for replacing 3mm drive pins in drive shafts. Use the HUDY replacement drive shaft pins 3x14 (#106050).
- Regularly inspect and replace the connecting pins which connect the center drive shafts with the pinion gear, and also the pins that connect the wheel drive shafts with wheel axles. Use HUDY Graphite Grease to lubricate the drive shaft connecting joints and the diff gears.
- Pivot balls and ball-joints will naturally wear for some time and will generate play. If there is too much play the pivot balls and ball joints need to be replaced.
- If the car is run in wet conditions, apply WD-40® on all drivetrain parts before the run. After the run, clean and dry the parts again.

HUDY SPRING STEEL™

The HUDY Spring Steel™ used in the car is the strongest and most durable steel material on the RC market. While items made from HUDY Spring Steel™ are still subject to wear, the lifespan is considerably longer than any other material. As parts made from HUDY Spring Steel™ wear, the brown color will after some time "go down" but it will not affect the strength of the material. The brown color is only a surface treatment and if the brown color will wear the durability of the part will be still strong.

THROTTLE LINKAGE ADJUSTMENT

NEUTRAL (IDLE)

ADJUST INDIVIDUAL LINKAGES SEPARATELY TO AVOID INTERFERING WITH THE OPERATION OF THE OTHERS

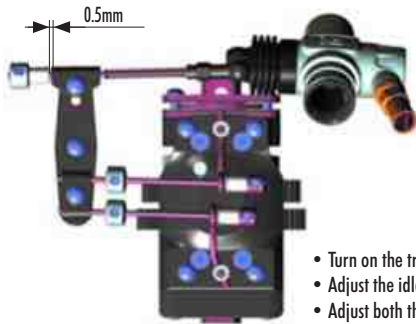

- Turn on the transmitter and receiver and set the engine control servo trim to the neutral position.
- Adjust the idle adjustment screw on the carburetor to open approx. 1mm.
- Adjust both the throttle linkage and brake linkages accordingly.
- DO NOT adjust the linkage with the engine running.

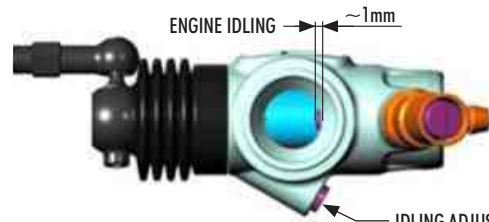

ENGINE IDLING ~1mm

IDLING ADJUSTMENT SCREW.
Use to adjust the idle setting of the carburetor. Do not allow carburetor to close to less than 1mm.

FULL THROTTLE

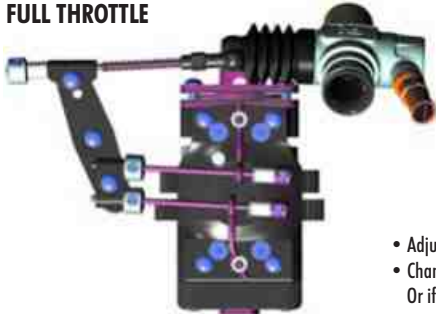

- Adjust the servo-horn mounting position for the carburetor to open fully.
- Change the pivot mounting position on the servo horn in case the carburetor is not opening fully or if it is opening excessively. Or if available on the transmitter, adjust the throttle high end point.



BRAKE



- Adjust the adjustable collars so the brakes work smoothly.
- If the brakes apply too much or not enough, adjust the adjustable collars accordingly. Or if available on the transmitter, adjust the brake endpoint.
- To tighten brakes, turn collar to thread brake rod INTO of pivot.
- To loosen brakes, turn collar to thread brake rod OUT of pivot.

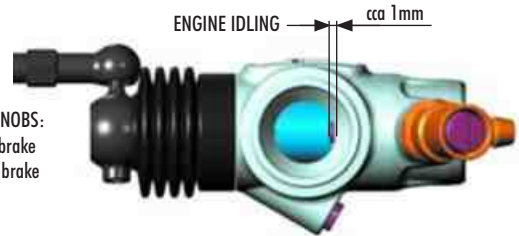

BRAKE ADJUSTING KNOBS:
Upper linkage - rear brake
Lower linkage - front brake

TROUBLESHOOTING GUIDE

PROBLEM	CAUSE	SOLUTION
ENGINE DOES NOT START	<ul style="list-style-type: none"> • Fuel tank is empty or carburetor is not primed • Bad glowplug or dead glowdriver battery • Fuel lines, fuel filter, air cleaner, or muffler is clogged • Engine is flooded due to over-priming • Carburetor is not adjusted properly • Throttle servo linkage not adjusted properly 	<ul style="list-style-type: none"> • Fill fuel tank with fuel and prime • Replace glowplug or recharge/replace glowdriver battery • Clean or replace clogged part(s) • Remove glowplug, turn car over to discharge fuel from cylinder. Test glowplug and replace if defective • Set idle and main/slow needle adjusting screw to standard starting position • Move throttle servo to neutral position and re-adjust linkage(s)
ENGINE STARTS BUT THEN STALLS	<ul style="list-style-type: none"> • Fuel tank is empty • Fuel lines, fuel filter, air cleaner, or muffler is clogged • Carburetor is not adjusted properly • Engine has overheated 	<ul style="list-style-type: none"> • Fill fuel tank with fuel • Clean or replace clogged part(s) • Re-adjust idle and main/slow needle adjusting screw • Allow engine to thoroughly cool down and open main needle adjusting screw 30° turn richer (CCW)
BAD REACTION AND RESPONSE FROM ENGINE	<ul style="list-style-type: none"> • Carburetor is not adjusted properly • Fuel lines, fuel filter, air cleaner, or muffler is clogged • Low fuel pressure from muffler 	<ul style="list-style-type: none"> • Re-adjust main/slow needle adjusting screw • Clean or replace clogged part(s) • Properly install pressure line between muffler and fuel tank
CAR IS HARD TO CONTROL	<ul style="list-style-type: none"> • Weak transmitter and/or receiver batteries • Low reception from radio antennas • Servo linkages not adjusted properly 	<ul style="list-style-type: none"> • Recharge or replace batteries • Fully extend transmitter and receiver antennas • Move servo to neutral then re-adjust linkage(s)
STEERING DOES NOT WORK PROPERLY	<ul style="list-style-type: none"> • Weak transmitter and/or receiver batteries • Bent linkages or driveshafts • Loose steering components • Drivetrain damage 	<ul style="list-style-type: none"> • Recharge or replace batteries • Check tightness of steering components and tighten if necessary • Replace damaged parts
HANDLING PROBLEMS	<ul style="list-style-type: none"> • Shocks are not working properly • Suspension is binding • Improper tires 	<ul style="list-style-type: none"> • Rebuild the shocks and replace worn or broken parts • Make sure suspension moves freely. Replace worn or broken parts • Use different tires
STEERING FEELS SLUGGISH OR VAGUE	<ul style="list-style-type: none"> • Suspension is binding • Damaged steering servo 	<ul style="list-style-type: none"> • Make sure suspension moves freely, and replace worn or broken parts • Check the steering servo for damage and wear, and replace/repair if necessary
THE CAR DOES NOT DRIVE STRAIGHT	<ul style="list-style-type: none"> • Suspension is binding • Steering trim is off-center • Wheels are loose • Damaged steering servo 	<ul style="list-style-type: none"> • Make sure suspension moves freely, and replace worn or broken parts • Adjust steering trim until car drives straight • Check the make sure the wheel nuts are properly tightened • Check the steering servo for damage and wear, and replace/repair if necessary

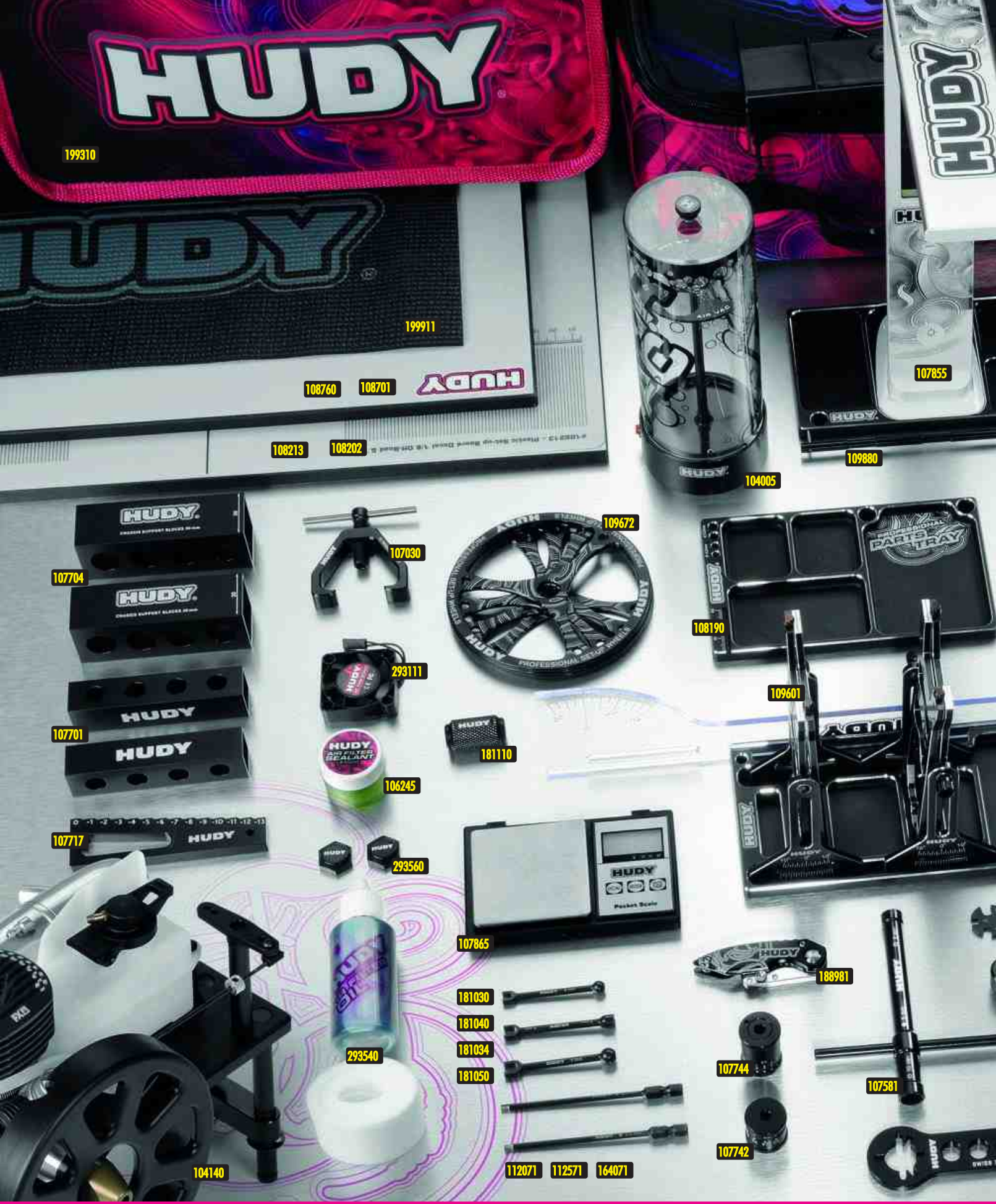

- #104005 HUDY Air Vac - Vacuum Pump - 1/8 Off-Road
- #104140 HUDY Engine Break-In Bench
- #104500 HUDY Star-Box 1/8 Off-Road
- #105500 HUDY Universal Tire Balancing Station
- #105510 Wheel Adapter for 1/8 Off-Road Cars, Truggy & Rally Game
- #106000 HUDY Drive Pin Replacement Tool (for 3mm Pins)
- #106200 HUDY Magic Cleaning Gum
- #106245 HUDY Air Filter Sealant
- #107030 HUDY Flywheel Puller
- #107090 HUDY Bearing Check Tool
- #107570 HUDY 17mm Off-Road Wheel Nut Tool
- #107581 HUDY Cross Wrench Glowplug # 8mm / Clutchnut # 10mm
- #107602 Limited Edition - Reamer for Body 0-18mm + Cover - Large

- #107612 Limited Edition - Exhaust Spring / Caster Clip Remover
- #107644 Limited Edition - Arm Reamer # 4.0mm
- #107701 Chassis Droop Gauge Support Blocks 20mm for 1/8 - LW(2)
- #107704 Chassis Droop Gauge Support Blocks 30mm 1/8 Off-Road - LW (2)
- #107717 Chassis Droop Gauge 0 to -13 mm for 1/8 Off-Road
- #107742 HUDY Adjustable Ride Height Gauge 20-30mm
- #107744 HUDY Adjustable Ride Height Gauge 30-45mm
- #107762 HUDY Adjustable Camber Gauge 110mm
- #107780 HUDY Adjustable Droop Gauge 80-140mm
- #107783 HUDY Droop Gauge 70-140mm
- #107855 HUDY Pit LED
- #107865 HUDY Ultimate Digital Pocket Scale 300g/0.01g
- #108170 HUDY Off-Road & Truggy Car Stand

- #108190 HUDY Alu Tray for Parts
- #108202 Flat Set-Up Board for 1/8 Off-Road & Truggy
- #108213 Plastic Set-up Board Decal for 1/8 Off-Road & Truggy
- #108701 Flat Set-Up Board for 1/8 Off-Road & GT - Lightweight
- #108760 Plastic Set-Up Board Decal 399x545mm - 1/8 Off-Road & GT
- #109601 HUDY Set-Up Station for 1/8 GT
- #108860 Alu Nut for 1/8 Off-Road System (4)
- #109672 Alu Set-Up Wheel for 1/8 GT (4)
- #109802 HUDY Alu Tray for 1/8 Off-Road Diff & Shocks
- #109841 HUDY Alu Tray for 1/8 Off-Road Diff Assembly
- #109860 HUDY Alu Tray for Set-Up System
- #109880 HUDY Alu Tray for Accessories & Pit LED
- #111545 Limited Edition - Allen Wrench # 1.5mm

EXCLUSIVE PROFESSIONAL

HUDY

199186

104500

HUDY

199060

109802

108170

105510

105500

199270

106200

106000

107762

107780

107783

107602

107090

183011

188990

107644

154060

107612

113045

112545

132545

112045

132045

111545

164045

175535

170050

109841

109860

181090

107570

182016

- #112045 Limited Edition - Allen Wrench # 2.0mm
- #112071 Power Tool Tip Allen 2.0 x 90 mm
- #112545 Limited Edition - Allen Wrench # 2.5mm
- #112571 Power Tool Tip Allen 2.5 x 90 mm
- #113045 Limited Edition - Allen Wrench # 3.0mm
- #132045 Limited Edition - Allen Wrench + Ball Repl. Tip # 2.0mm
- #132545 Limited Edition - Allen Wrench + Ball Repl. Tip # 2.5mm
- #154060 Long Slotted Screwdriver 4.0 mm - for Engine Adjust. - SPC - V2
- #164045 Limited Edition - Phillips Screwdriver # 4.0mm
- #164071 Power Tool Tip Phillips 4.0 x 90 mm
- #170050 Socket Driver 5.0 mm
- #175535 Limited Edition - Socket Driver # 5.5mm
- #181030 HUDY Spring Steel Turnbuckle Wrench 3 mm

- #181034 HUDY Spring Steel Turnbuckle Wrench 3 & 4mm
- #181040 HUDY Spring Steel Turnbuckle Wrench 4 mm
- #181050 HUDY Spring Steel Turnbuckle Wrench 5 mm
- #181090 HUDY Special Tool For Turnbuckles & Nuts
- #181110 HUDY Ball Joint Wrench
- #182016 Wheel Nut & 3/4 Shoe Flywheel Multi-Toll 1/8 GT
- #183011 HUDY Professional Multi Tool
- #188981 HUDY Pocket Hobby Knife
- #188990 HUDY Professional Body Scissors
- #199060 HUDY Alu Tool Stand
- #199186 HUDY Car Bag - 1/8 On-Road GT
- #199270 HUDY LiPo Safety Bag
- #199310 HUDY Pit Bag - Compact

- #199911 HUDY Pit Mat Roll 750x1200mm with Printing
- #293111 HUDY Brushless RC Fan 40mm
- #293540 Air Filter Foam & Oil (10) - XRAY XB8 Low Profile Style
- #293560 HUDY Alu Wheel Nut with Cover - Ribbed (2)

For more information about tools, set-up equipment and accessories suitable for your car please visit:

www.hudy.net

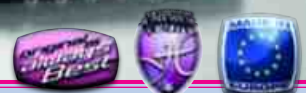

www.teamxray.com

XRAY EUROPE

XRAY, K VÝSTAVISKU 6992, 91101 TRENCIN, SLOVAKIA, EUROPE
PHONE: +421-32-740 11 00, FAX: +421-32-740 11 09, info@teamxray.com

XRAY USA

RC AMERICA, 2030 Century Center Blvd #15, Irving, TX 75062, USA
PHONE: 214-744-2400, FAX: 214-744-2401, xray@rcamerica.com



/TeamXray



/TeamXray



/TeamXray



/XrayRacing



/+TeamXrayRC



/XrayRacing