

YZ-4 SF

SETTING SHEET Ver.01

CIRCUIT 2017 IFMAR World Championship in China

DRIVER Ryan Maifield DATE 2017/11/19

INDOOR OUTDOOR
 DIRT ASTROTURF CARPET GLASS WOOD
 WET DRY DUSTY SMOOTH BUMPY
 HARD PACKED CLAY BLUE GROOVE _____
 LOW TRACTION MED TRACTION HIGH TRACTION

FRONT

◆ CAMBER ● ← → ○ 2 °
 ◆ TOE ○ IN ● OUT 1 °
 ◆ RIDE HEIGHT 19 mm

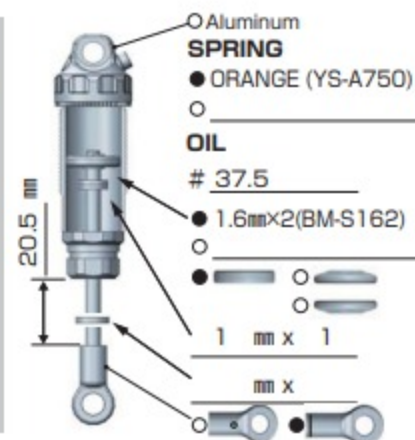
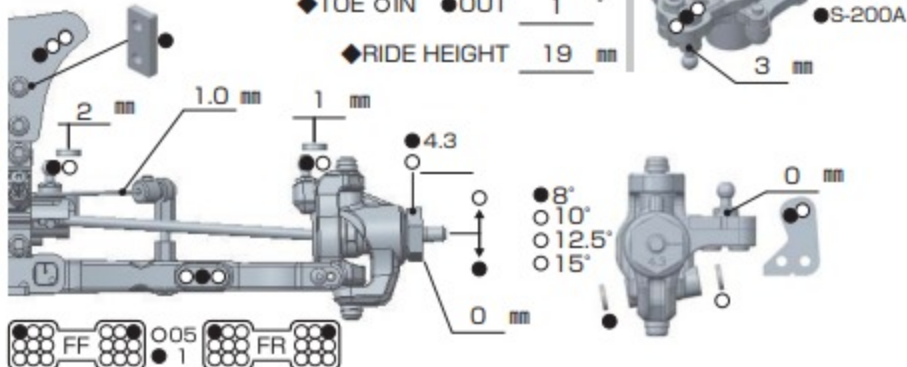

REAR

◆ CAMBER ● ← → ○ 2 °
 ◆ RIDE HEIGHT 20 mm

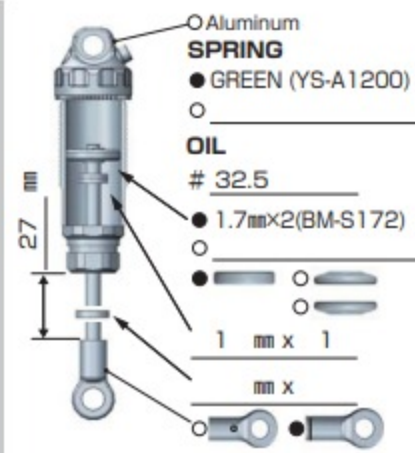
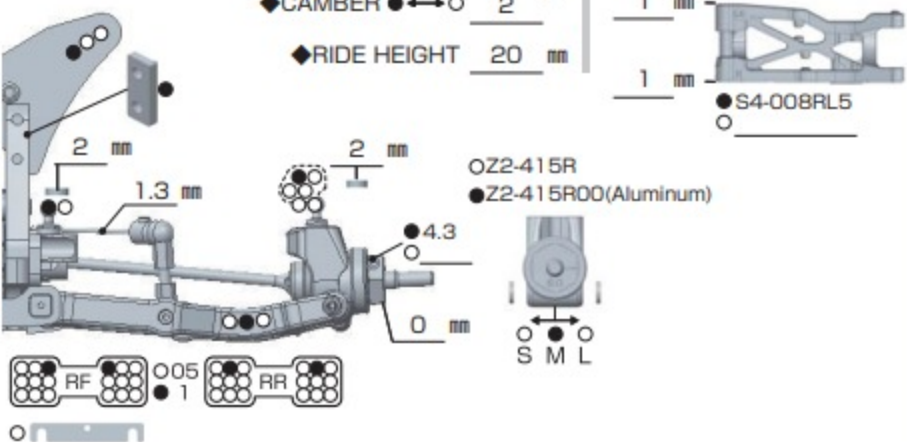

DRIVE

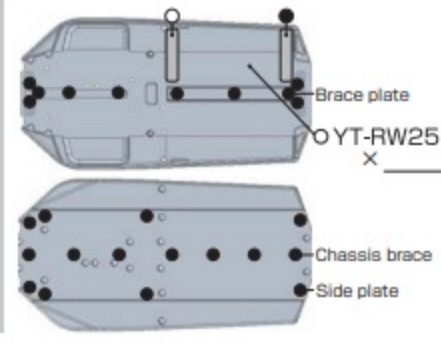
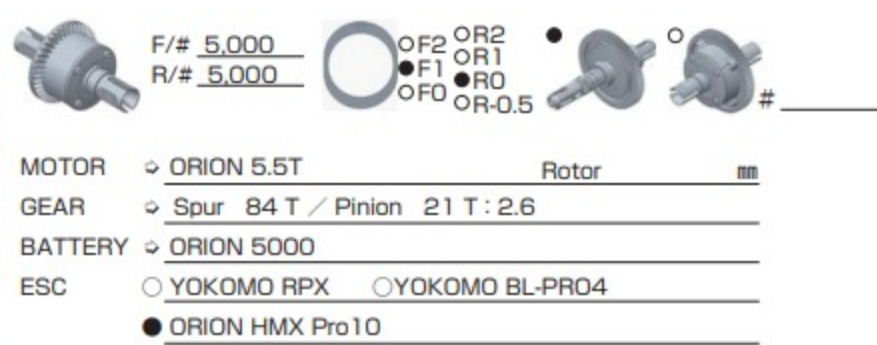

TIRE

FRONT	TIRE	⇨ Sweep Tendroid (Yellow)	REAR	TIRE	⇨ Sweep Tendroid (Yellow)
	INSERTS	⇨ Sweep Orange		INSERTS	⇨ Sweep Orange
	WHEELS	⇨ B4-821W		WHEELS	⇨ JConcepts

OTHER

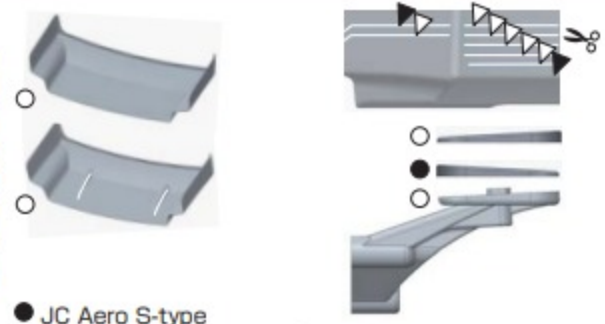

COMMENT

S4-203A0
 S4-TBS
 S4-412WS
 Z2-S2ST
 Z2-S2LT
 B4-413A8
 ZC-204517
 RP-087