

Setup: Indy high grip

Full details in app: sodialed.com/s/bDXc

Front Suspension:

| | |
|-----------------|---|
| Ride Height: | 16 mm |
| Camber: | Left +1 right -1 degrees |
| Toe: | +1 degrees |
| Anti-Roll Bar: | None |
| Arm Type: | Gull-wing |
| Tower Type: | B6.3 Gull-wing |
| Wheel Hex: | 5mm Aluminum |
| Steering Block: | 4 mm |
| Caster: | 30 deg - Kick-up: 25 / Block insert: +5 |
| Bulkhead Type: | Plastic |
| Kick-Up Angle: | |
| Notes: | |

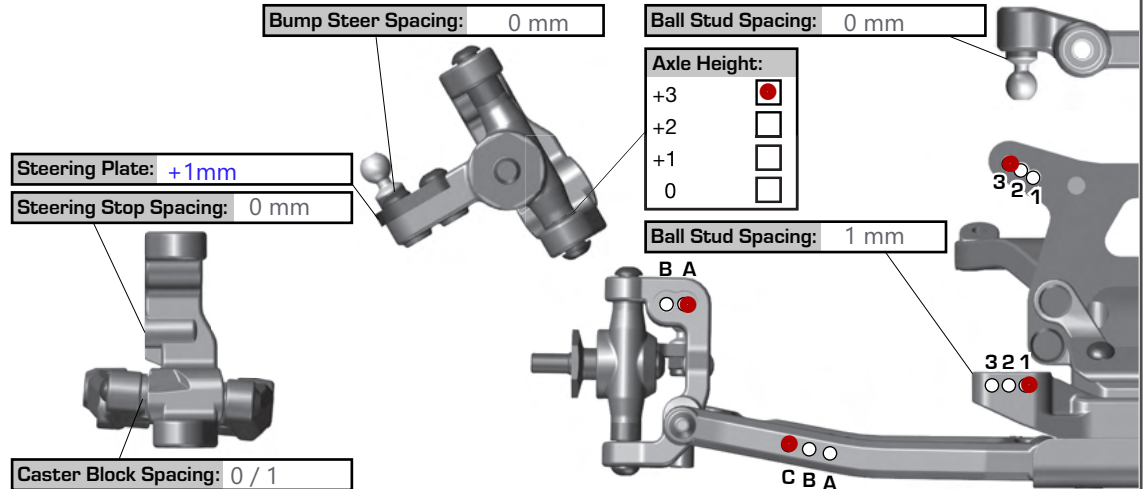

Rear Suspension:

| | |
|--------------------------|--|
| Ride Height: | 16 mm |
| Camber: | Left +2 right -1.5 degrees |
| Anti-Roll Bar: | None |
| Arm Type: | 73mm |
| Tower Type: | Wide |
| Arm Spacing: | Short (forward) |
| Wheel Hex: | 5mm |
| Shock Mounting Position: | Front of Arm <input checked="" type="checkbox"/> Rear of Arm <input type="checkbox"/> |
| Hub Spacing: | Fwd <input type="checkbox"/> Mid <input type="checkbox"/> Back <input checked="" type="checkbox"/> |
| CVA Bone Length: | 69mm |
| CVA Axle Type: | |
| Notes: | |

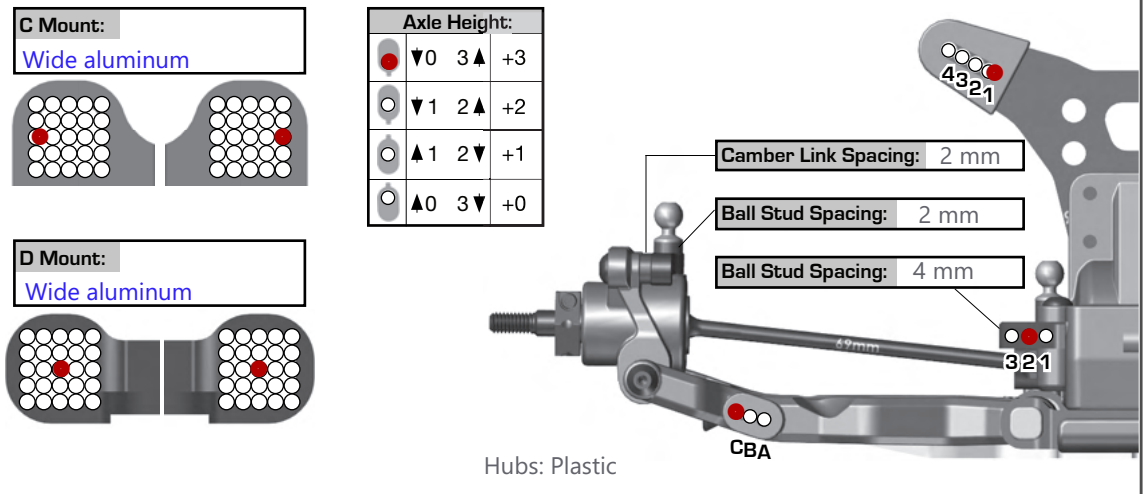

Electronics:

| | | | |
|-------------------|-------------------------------|----------|----------|
| Radio: | Futaba | Servo: | Nitropro |
| EPA: | Throttle: 100 % | Brake: | % |
| ESC: | Hobbywing | Xr10 pro | |
| ESC Settings: | | | |
| Motor: | Power Products Nathan Dean | | |
| Wind: | 13.5 | Timing: | |
| Pinion: | 28 | Spur: | 78 |
| Battery: | Zee | | 6000 |
| Battery Position: | Front hole / 3 | | |
| Battery Weight: | | | |

Drivetrain:

| | |
|-----------------|-------------------------------------|
| Transmission: | Layoutdown |
| Differential: | Ball Diff: <input type="checkbox"/> |
| Height: | 3 mm |
| Gear Diff: | <input checked="" type="checkbox"/> |
| Gear Diff Mass: | Ball diff cst |
| Notes: | |
| Slipper Clutch: | Type: Slipper |
| # of Pads: | 2 x 11mm ID Octalock LCF |
| Setting: | |

Shocks:

| | | |
|----------------|--|--------------------|
| Oil: | PT RC | |
| | Front | Rear |
| Piston: | 2mm 2x1.5mm FT | 2mm 2x1.6mm FT |
| Fluid: | 450 cst | 450 cst |
| Spring: | Custom works red | Custom works green |
| Limiters: | int/ext: 0 / 0 mm | int/ext: 1 / 0 mm |
| Stroke: | 24 mm | 28 mm |
| Eyelet Length: | +0mm Short false | +2mm Long false |
| Cup Offset: | 5 mm | 0 mm |
| | Right front 5.96mm front left 3.39. Left rear 10.5mm right rear 5.98mm | |

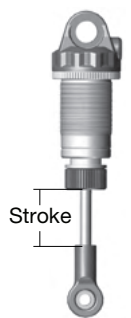

Track Info:

| | |
|-------------------|---------------------------------|
| Size: | Tight |
| Surface: | Indoor blue groove |
| Traction: | High |
| Moisture: | Dusty |
| Condition: | Smooth |
| Temperature: | Ambient: -1C/30F Track: -1C/30F |
| Notes: | |
| Vehicle Comments: | |

Tires:

| | |
|-----------------|-------------------|
| Front Tires: | 10droid 2.2 |
| Front Compound: | Super soft |
| Front Insert: | |
| Rear Tires: | Orbit |
| Rear Compound: | Super soft |
| Rear Insert: | |
| Wheel (F/R): | F: Sweep R: Sweep |
| Notes: | |

Body, Weight:

| | |
|-----------------------|-----------|
| Body: | Kit |
| Front Wing: | Kit |
| Rear Wing: | Kit |
| Wing Angle: | 6 degrees |
| Chassis Length: | B6.3 +3mm |
| Servo Weights: | |
| Electronic Weights: | |
| Total Vehicle Weight: | |