

Inverted Metallurgical Microscope

Model Number

NIM-100

User Manual

This manual is written for Inverted Metallurgical Microscope of NIM-100. To ensure the safety, obtain optimum performance and to familiarize yourself fully with the microscope, it is strongly recommended that you read this manual carefully before operating the microscope.

User Notices	ii -iii
1 Components Name	1
2 Assembly	2
3 Adjustment Set Diagram	7
4 Adjustment procedures	9
4-1 Microscope Body	9
4-2 Mechanical Stage	11
4-3 Viewing Tube	12
5 Microscope Photography and Video	13
5-1 Microscope Photography	13
5-2 Microscope Video	14
6 Technical Specifications	16
7 Trouble Shooting	17

I Safety Precautions

! Make sure that the input voltage is consistent with the power supply voltage, or it will bring a serious damage to the instrument.





1. Be careful when moving the microscope, to avoid the lenses dropped or damaged.
2. Do keep the microscope out of direct sunlight, high temperature or humidity, dusty and easy shaking environment. Make sure the stage is smooth, horizontal and firm enough.
3. When moving the instrument, grip two sides of the bottom of the microscope with your two hands.
4. When running, the lamp house and nearby parts will be very hot. Please ensure there is enough cooling room for them.
5. Make sure the instrument is earthed, to avoid lighting strike.
6. For safety, be sure the main switch is in "O"(off) state and cut off the power supply before replacing the bulb or the fuse. If you replace the bulb during use or right after use, allow the lamp bulb and the lamp house to cool completely before touching.
(Designated bulb: 6V30W Halogen Lamp)
7. Check the input voltage: be sure the input voltage which is signed in the back of the microscope is consistent with the power supply voltage, or it will bring a serious damage to the instrument.

II. Maintenance and Care

1. All the lenses have been adjusted properly; do not dismount them by yourself please.
2. The nosepiece and coarse and fine focusing parts are so delicate that it is forbidden to disassemble them carelessly by yourself.
3. Keep the instrument clean, and do not pollute the optical element when wiping away the dust on the instrument.
4. The contaminations on the prism, like fingerprints and oil smudges, could be gently wiped with a piece of soft cloth or tissue paper, gauze which has been immersed in pure alcohol or ether. (Note that the alcohol and ether are highly flammable, do keep them away from the fire or potential sources of electrical sparks, and use them in a drafty room as possible as you can.)
5. Do not attempt to use organic solvents to clean the microscope components other than the glass components. To clean them, use a lint-free, soft cloth slightly moistened with a diluted neutral detergent.
6. When using, if the microscope is splashed by liquid, cut off the power at once, and wipe away the splash.
7. Do not disassemble any parts of the microscope, as this will affect the function or reduce the performance of the microscope.
8. Place the instrument in a cool, dry position. After using the microscope, remember to cover it

with dust helmet. Do wait for the lamp house cooling completely before cover.

III、 Safety Symbols

Symbol	Explanation
	Indicates that the surface becomes hot, and should not be touched with bare hands.
	Before use, carefully read the user manual .Improper use could result in personal injury to the user and/or damage to the equipment.
	Indicates that the main switch is ON.
	Indicates that the main switch is OFF.

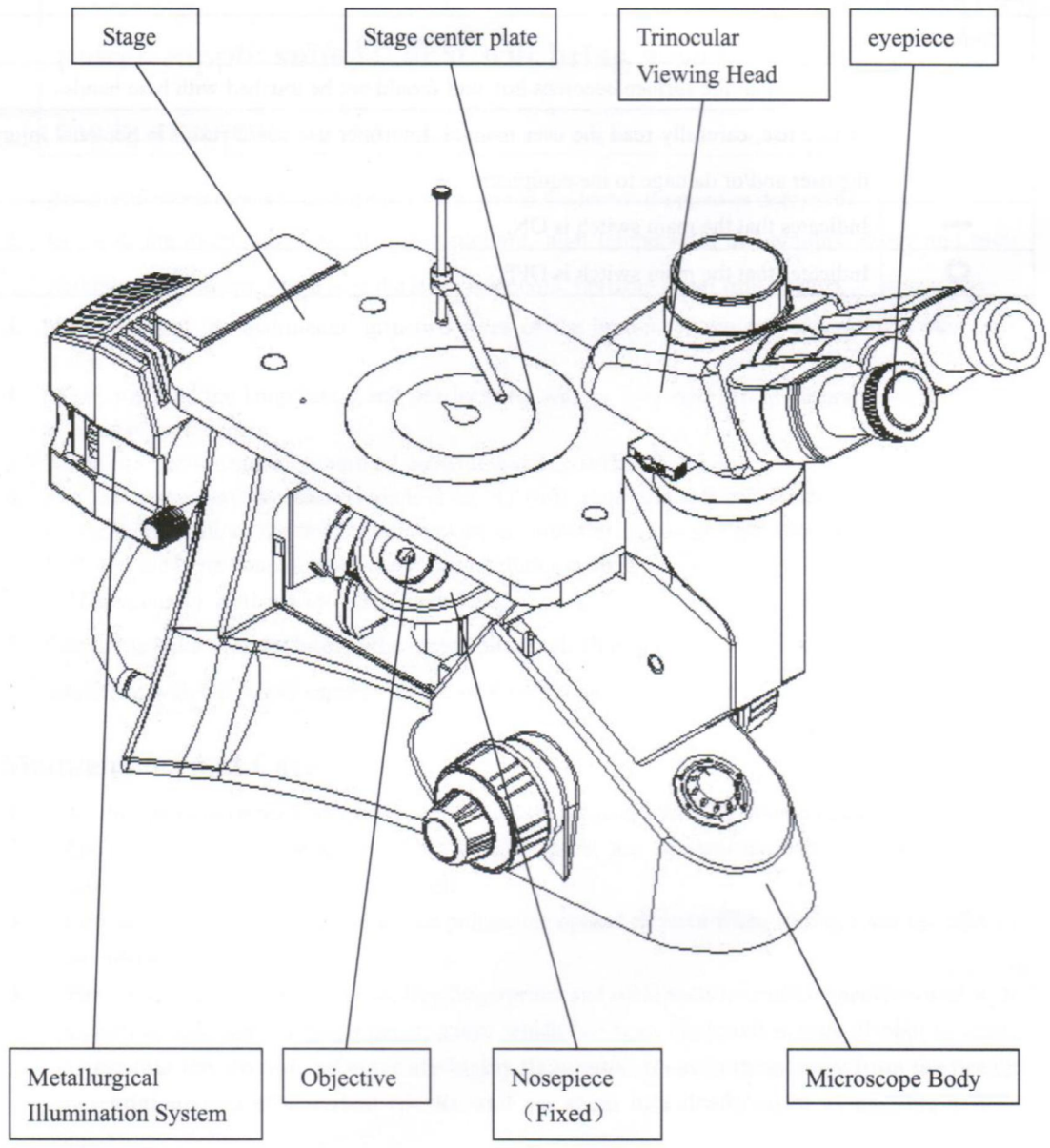

Fig.1

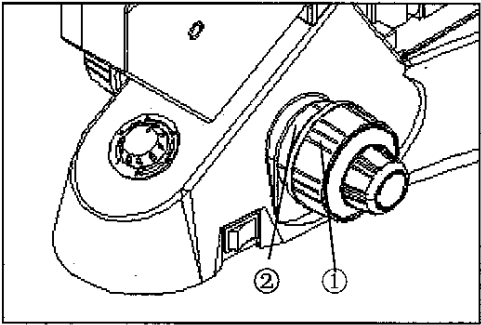

Fig.2

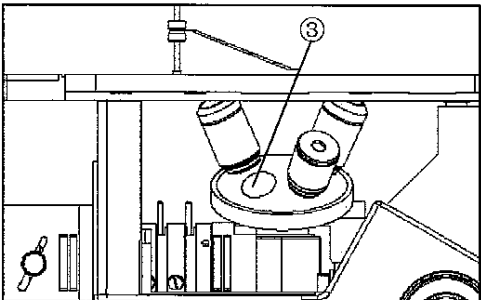

Fig.3

Mounting the Objectives

(Fig.2 and Fig.3)

1. Turning the coarse focusing knob① as the figure shows till the nosepiece gets to its lower limit.
 - ★ For ensuring the safety of the instrument during transportation, the nosepiece is located in the lowest position and the tension adjustment collar② is adjusted to an appropriate tension while leaving the factory.
2. Screw the lowest magnification objective on to the nosepiece from the nearside, then turn the nosepiece clockwise, mount other objectives according the magnification sequence of low to high.
 - ◎ Mounting objective in this way will make it easier to change magnification.
 - ◎ The objective can also be mounted through the opening on the stage.
 - ★ Clean the objective periodically, for the objectives used in the inversed microscope are susceptible to dust.
 - ★ Do cover all the unused holes③ on the nosepiece with dust caps, to prevent the dirt and dust from getting inside.
 - ★ When operating, use the low magnification objective (10X) to search and focus the specimen at first, then replace with the higher magnification objective if necessary.
 - ★ When replacing the objective, turn the nosepiece slowly until you hear “clicked”, that means the objective enters into the right position—center of the light path.

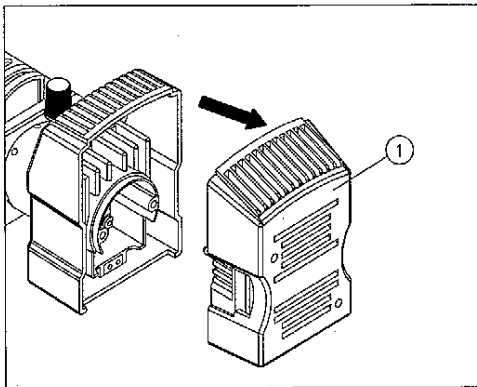

Fig.4

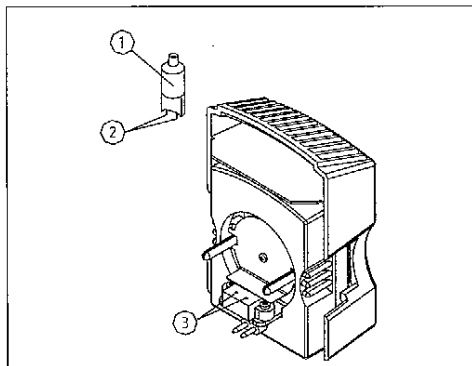

Fig.5

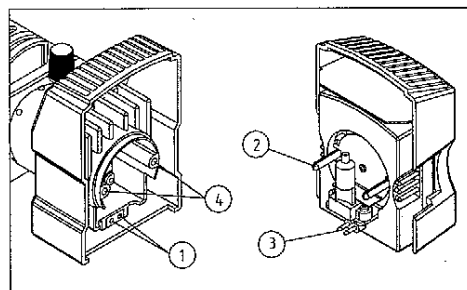

Fig.6

■ Mounting Auxiliary Stage and the Mechanical Ruler

- ◎ Auxiliary stage can be installed in either side of the stage to enlarge the stage surface. But you can't install the mechanical ruler at the same side.
- ◎ Generally, the mechanical ruler will be installed at the right side for comfortable operation.

1. Installing the auxiliary stage

First, Screw the clamping bolts into to the auxiliary stage, then into the main mechanical stage from below on right or left side; Tighten it with a screwdriver until the auxiliary stage is securely attached.

2. Installing the mechanical ruler

Please install the ruler in the same way as the auxiliary stage.

■ Installing and Replacing the Bulb (Fig.4-Fig.7)

- ◇ Please use the specified halogen Lamp 6V30W.

1. Pull out the lamp house① as shown in fig.4
2. Holding the bulb ① with a piece of gauze or other protection materials, insert the bulb pins straight and fully into the pin holes③ on the lamp house. (Fig.5)
3. Bulb replacement during use or right after use. The bulb, the lamp house and nearby parts will be very hot. Please set the main switch to "O" (off), disconnect the power cord, and make sure the bulb, the lamp house and periphery are all cool. Then, you can do your replacing.

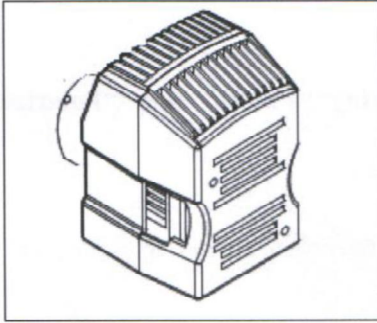

Fig.7

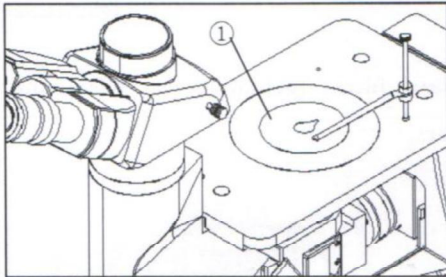

Fig.8

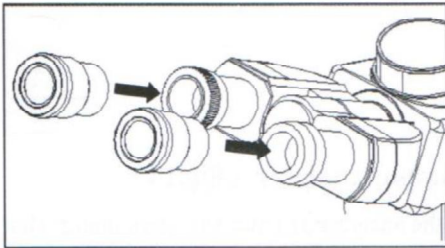

Fig.9

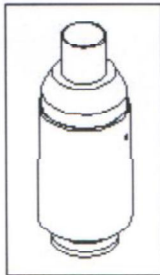

Fig.10

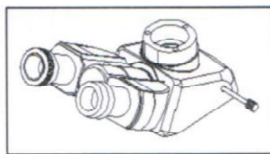

Fig.11

★ Please insert the lamp gently, or it will be damaged by excessive extrusion.

★ Do not touch the halogen bulb with bare hands. It will shorten the service life or cause it to burst. If you leave fingerprints on the surface carelessly, clean it with a piece of dry soft cloth.

4. Align the socket① with pins③, and the bolts② with the jacks④. then push the lamp-house all the way into place. (Fig. 6-7)

2-4 Installing the Stage Center Plate (Fig.8)

1. When using the glass stage ①, there is no special requirement, you just need to place it in the center of the mechanical plain stage.

2. Install the stage center plate on to the stage opening.

2-5 Installing the Eyepiece (Fig.9)

1. Remove the cap of the eyepiece tube.

2. Insert the eyepiece into eyepiece tube until they are against each other.

2-6 Mounting the video (photography) adapter(Fig.10,11,12)

Insert the video (photography) adapter tube (Fig.10) into the trinocular viewing head (Fig.11),and screw down the bolt to fix it, as shown in Fig.12.

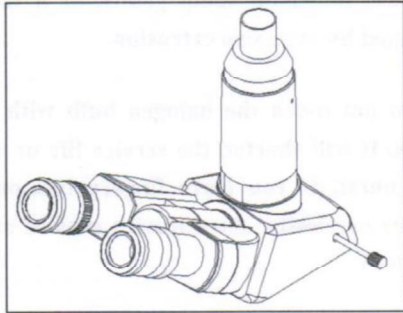

Fig.12

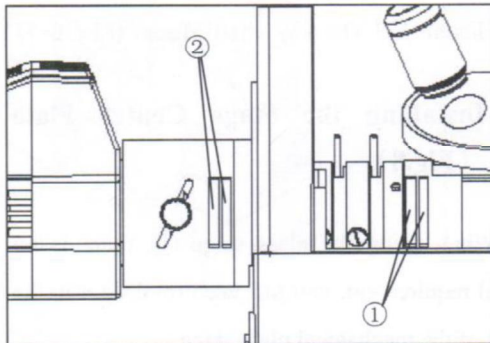

Fig.13

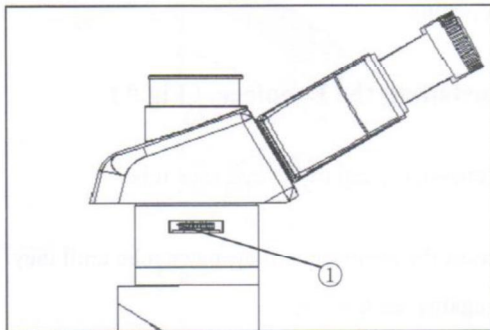

Fig.14

2-7 Mounting Filters and Polarizer (Fig.13)

Insert the filter ① into the corresponding jack.

For polarization observation, insert the polarizer ② into the right jack, as shown in Fig.13.

★ Standard filters include blue, yellow and green filters.

2-8 Mounting Analyzer (Fig.14)

Insert the analyzer ① into the jack under the trinocular viewing head if necessary, as shown in Fig.14

★ Analyzer can be used alone or matched with the polarizer.

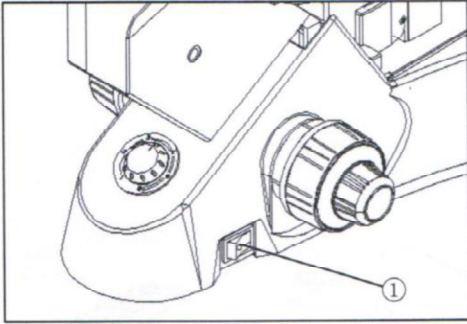

Fig.15

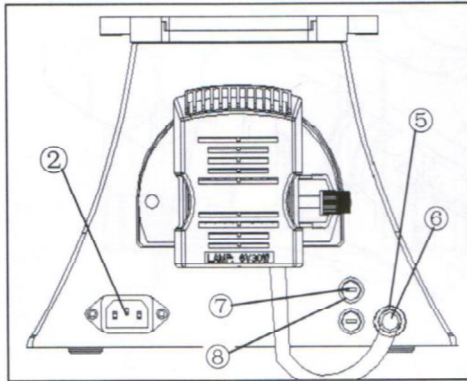

Fig.16

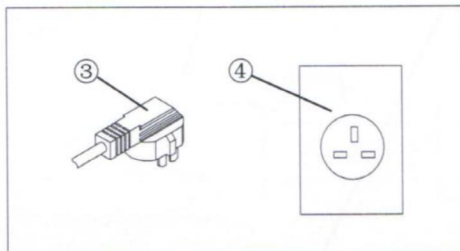

Fig.17

2-9 Connecting the Power Cord (Fig.15, Fig.16 and Fig.17)

★ The cable and cords are vulnerable when bent or twisted, never subject the power cord to excessive force.

1. Set the main switch① to “0” (off) state before connecting the power cord.
2. Insert the plugs into the power jack② of the microscope safely.
3. Plug the power cord ③ into the power supply receptacle④. Make sure the connection is well.
4. Insert aviatic BNC connector plugs⑥ into aviatic BNC connector jack⑤.

★ Do use the supplied power cord all the time. If lost or damaged, select the same standard cord, please.

★ Connect the power cord correctly, to ensure the instrument is grounded.

2-10 Replacing the Fuse (Fig.15-16)

Do remember to set the main switch① to the state of “O” (OFF) and unplug the power cord before replacing the fuse. Rotate the fuse⑦ kits out of the holder⑧ with the “—” type screwdriver, replace with a new fuse, then rotate it back to the holder again.

★ Fuse rating: 250V, 500mA.

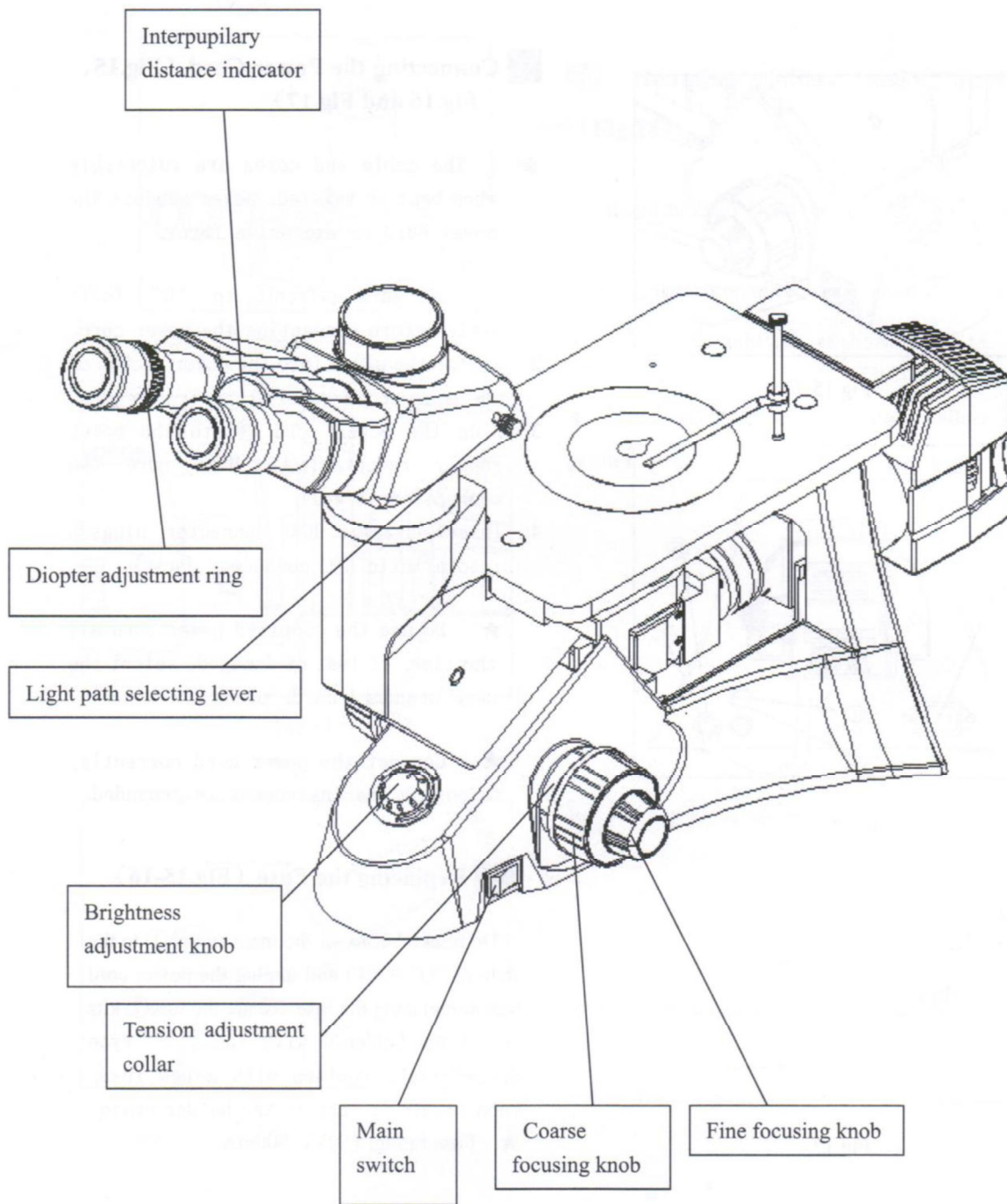

Fig.18

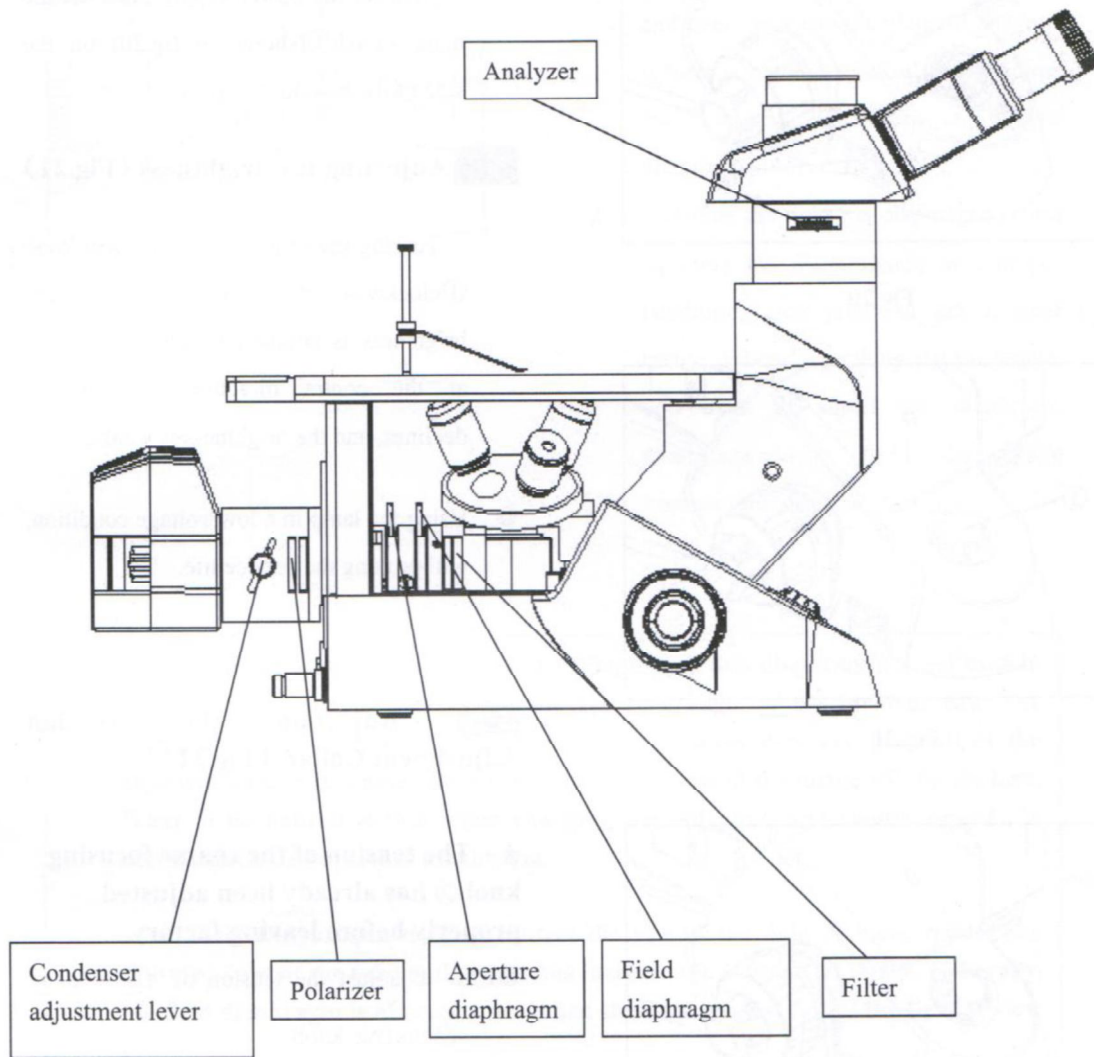

Fig.19

4-1 Microscope Base

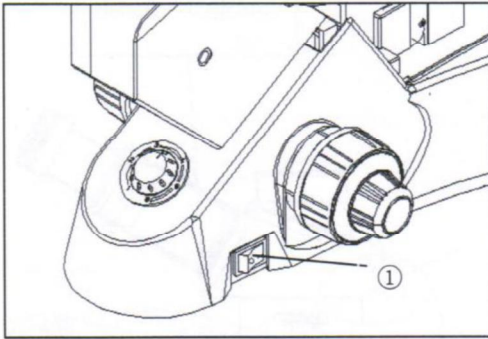

Fig.20

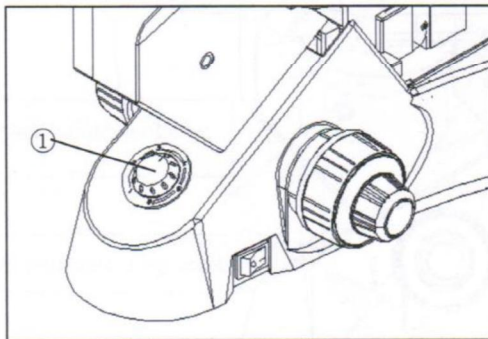

Fig.21

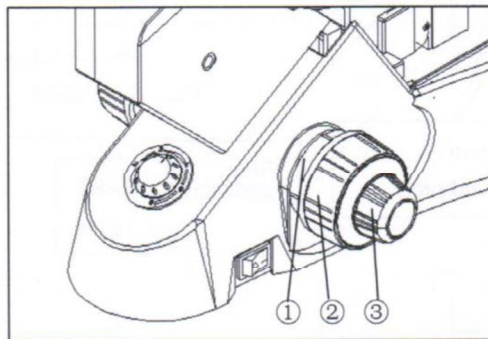

Fig.22

4-1-1 Turning On the Lamp (Fig.20)

Connect the power supply ,then set the main switch①(shown in fig.20) on the side of the base to “—”(on).

4-1-2 Adjusting the brightness (Fig.21)

Turning the brightness adjustment knob ①clockwise, the voltage raises, and the brightness is strengthen; whereas turning at the contra direction, the voltage declines, and the brightness is weaken.

- ◎ Using the lamp in a low voltage condition, will prolong the service life.

4-1-3 Adjusting the Tension Adjustment Collar (Fig.22)

★ The tension of the coarse focusing knob② has already been adjusted properly before leaving factory.

- ◎How to adjust the tension of the coarse focusing knob

Turn the tension adjustment collar ①. while revolving at the direction of the arrow in the figure, the tension of the coarse focusing knob② is increasing; and if at the contra direction ,the tension will decline.

If the nosepiece descends on its own, or the specimen gets out of focus soon even you focus with the fine focus knob③, It means the coarse focusing knob is too loose .you should screw the tension adjustment collar down at the direction of the arrowhead in fig.21 to increase the tension.

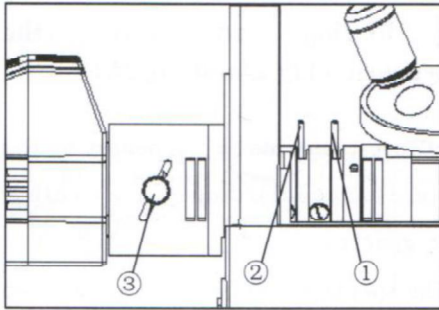

Fig.23

4-1-4 Adjusting the Illumination Set (Fig.23)

1. Make sure the field of view is bright and even, and has no filament shadow. If there is filament shadow, please adjust the condenser adjustment knob③ to proper position.
2. Adjust the field iris diaphragm① and Aperture iris diaphragm② to a proper condition, then you can get a clear image. When searching for the image, you need to adjust the diaphragm simultaneously until the image becomes sharpest.

★ **Aperture Diaphragm:** the aperture diaphragm (iris diaphragm) is not used to control the brightness but control the aperture angle of the incident ray. The diaphragm is not adjusted properly until the incident rays are just full of the objective lens. In this case, the contrast and sharpness of the image will be the best. What to be noticed is that when changing the objective, you should repeat the adjustment of the aperture diaphragm.

★ **Field Diaphragm:** used to control the size of the field of view, reduce the reflected rays of the tube and glare, thus increase the contrast of image. Generally, the field diaphragm is of proper size when the rays are just full of the field of view of eyepiece.

4-2 Stage

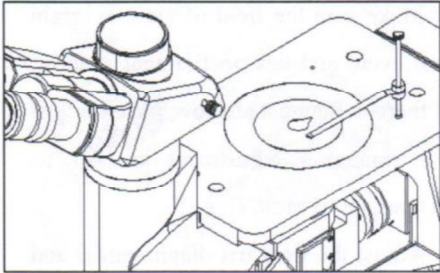

Fig.24

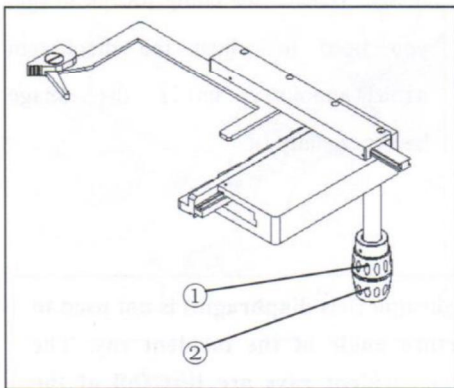

Fig.25

4-2-1 Placing and Moving the Specimen (Fig.24 and Fig.25)

1. Place the slide in the center of the stage and use the stage clips to clamp it gently.
2. The specimen can be moved to desired position by turning the X-axis knob ① and Y-axis knob ②. (stroke: 120mm along X-axis direction, 78mm along Y-axis direction.)

★ Be careful when changing the objectives. If you finish the observation with the short working distance objective, and want to change another one, be careful of not letting the objective touch the stage center plate or specimen slide.

4-3 The Viewing Tube

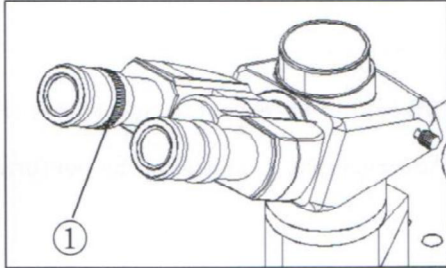

Fig.26

4-3-1 Adjusting the Diopter (Fig. 26)

1. Looking through the right ocular with your right eye, revolve the coarse and fine focusing adjustment knob to focus on the specimen.
2. Then use your left eye to look through the left ocular. If the image is not sharp, turn only the diopter adjustment ring ① to focus on the specimen please.

★ There are ± 5 diopters on the diopter adjustment ring. The number which the reticle on the eyepiece holder points to is your eye's diopter graduation.

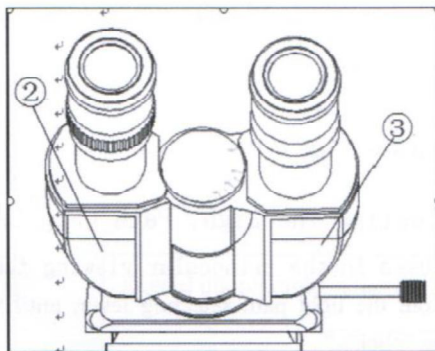

Fig.27

4-3-2 Adjusting the Interpupillary Distance (Fig.27)

When observing with two eyes, hold on the left and right prism holders ②、③, turn them around the axis to adjust the interpupillary distance until the left and right fields of view coincide completely.

★ The scale on the interpupillary distance indicator, pointed by the dot “.” on the eyepiece holder, shows the interpupillary distance. (Fig.27)

The range of the interpupillary distance: 48~75mm.

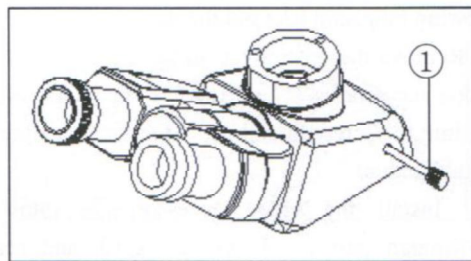

Fig.28

4-3-3 Switching the Light Path(Fig. 28)

- ⊙ Slide the light path selector lever ① by your thumb to select the light path you need.
- ⊙ For the binocular observation, push in the lever until you hear “clicked” .while for video or photography, pull out the lever until it reaches the “clicked” position.

Light Path Selecting Lever	Brightness Proportion	Application
Pushed in	100% used for binocular observation	Binocular observation
Pulled out	20% used for binocular observation, and 80% used for video or photography	Binocular observation and television \micrography \ video can be performed simultaneously.

4-3-4 Polarization Observation

- 1、 Mounting the polarizer and analyzer ,the detail is available in section 2-7、 2-8。
- 2、 The analyzer hand wheel can be rolled from 0° to 90° . When the field of view becomes the darkest, the orthogonal polarization position is reached and polarization observation can be performed.

5. Microscope Video and Photography

5-1 Microscope Video

5-1-1 Selecting the Light Path (Fig. 29)

- ★ Just used in the trinocular viewing tube.
Pull out the light path selecting lever, until you hear the “clicked”.
- ★ For the observation of dark specimen, you can focus it through the binocular at first, then change the light path.

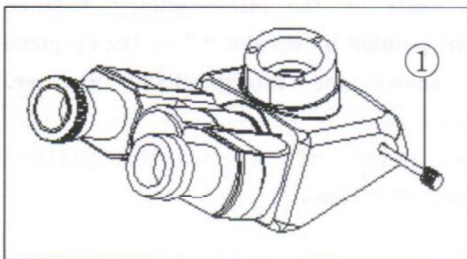

Fig.29

5-1-2 Installing the Video Set (Fig.30)

1. Loosen the locking bolt① on the trinocular viewing tube, and take out the dust cap②.
2. Remove the dust cover on the both ends of the video accessories③, and revolve the CCD/CMOS set into the screw thread end---the video adapter④ with C mount..
3. Install the video accessories③ into the tri-through port as shown in fig.30, and screw down the bolt①.

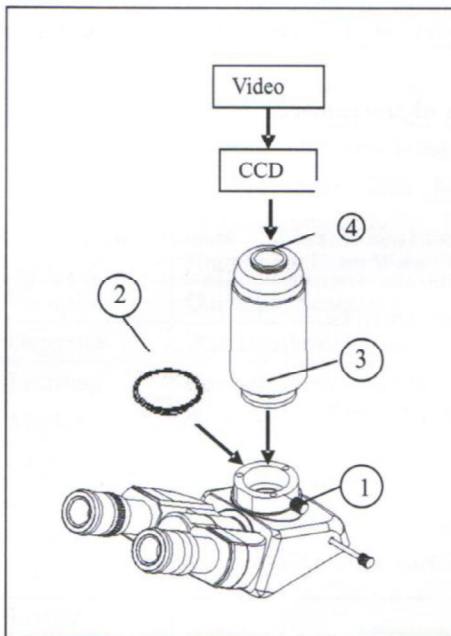

Fig.30

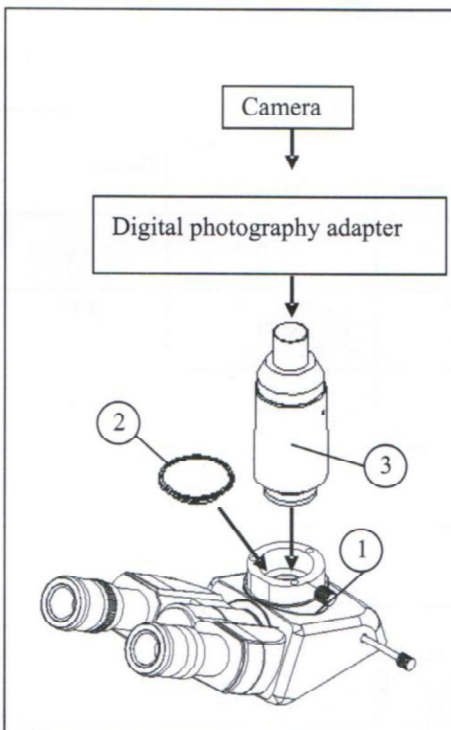

Fig.31

5-1-3 Focus (Fig.30)

Looking through binocular, focus the specimen to get a sharp image, and then check the image on the TV or the computer which is connected with the microscope video set. If it is not clear, please revolve video adapter④ until the image is sharp enough.

5-2 Microscope Photography

5-2-1 Selecting the Light Path

★ Just used in the trinocular viewing tube.

5-2-2 Installing the Photography Set (Fig.31)

1. Loosen the locking bolt① on the trinocular viewing tube, and take out the dust cap②.
2. Install the photography accessories③ into the tri-through port, and screw down the locking bolts①.
3. Couple the digital photography adapter with the camera set, then insert the adapter into the accessories③.
 - Before connecting the camera set with the digital photography adapter, please remove the camera gun firstly. Pay attention to the camera port type, please.
 - To avoid disturbing from the binocular, please place the viewfinder toward the side of the microscope when installing the camera set.
 - The magnification of photomicrograph = magnification of objective × magnification of photography adapter.

- ★ When shooting the micrograph, the shutter release will bring some impact. In order to weaken the impact and obtain a clear image, you could select a longer time of exposure or decrease the brightness to have some compensation.
- ★ This explanation is used for Nikon single-lens reflex digital camera.

5-2-3 Focus

Do the binocular observation and focus the specimen firstly. When in microscope photography, do use the camera viewfinder to focus the specimen. Please refer to the user manual of the photo attachment to obtain the details.

5-2-4 Adjusting the Color Temperature

- ◎ When shooting the chromophotograph with the sunlight film:
 1. Mount the blue filter into the filter bracket.
 2. Turn the brightness adjustment knob to the maximal limit, then you can obtain a sunlight illumination.

6-1 Main Technical Specification

Optical System	Infinite Optical System
Viewing Tube	Compensation Free Trinocular Tube Inclined at 30; interpupillary distance: 48-75mm Division ratio: 20% for Binocular Viewing and 80% for Video Viewing & photomicrography
Eyepiece	High Point ,Extra Wide Field Eyepiece EW 10X/20
Nosepiece	Quintuple Nosepiece
Objective	Plan achromatic objective :4×,10×, 20×,40×,80× (Optional) .
Focusing System	Coaxial Coarse and Fine Focusing adjustment ,Vertical Objective Movement , Coarse Stroke:37.7 mm per rotation, Fine Stroke:0.2mm per rotation
Stage	Area: 160×250mm
Mechanical ruler (Optional)	X/Y Coaxial Control at Right Hand Side, Moving Range: 120 (width) ×78 (Length) mm
Kohler Illumination	Halogen Lamp 6V30W, Preset Center, Intensity Continuously Adjustable
Filter	Blue, Yellow, Green and Ground Glass

6-2 Objectives Specification

Magnification	Aperture Number (N.A)	Working Distance (mm)	Conjugate Distance (mm)
4X	0.1	25.4	∞
10X	0.25	11	∞
20 X	0.4	6	∞
40 X	0.6	3.7	∞
80 X	0.9	0.2	∞

7. Trouble Shooting

NIM-100

If you meet trouble during operation, please take proper measures according to the follow list. If you can't solve the trouble by the supplied methods, please contact with the sales department of our company.

Trouble	Cause	solution
1.optical system		
1、 although the illumination is on,the field of view is dark.	The poor contact exists in the lamp house and the illumination system.	Connect it securely
	The lamp bulb is burned out.	Replace it with a new one
	The brightness adjustment knob is set too dark	Adjust the knob in a proper position
	The mounted bulb is not the specified one.	use the specified halogen Lamp 6V30W
2、 The edge of the field of view has shadow or not evenly illuminated	The nosepiece is not located in the required position	Adjust it into the right position
	The surface of the bulb becomes black	Change a new lamp bulb
	The filament shadow not clean up	move the Condenser adjust knob to eliminate the filament shadow
3、 Find dust and stain in the field of view	The surface of the lens is moldy or has contaminant	Clean the lens
	There are stains on the eyepiece	Clean the eyepiece
4.The image is defocused, of low-resolution	There are stains on the eyepiece	Clean the eyepiece
	The objective damages	Mend and correct the objective (send to factory for overhauling)
	The lens of the objective and eyepiece is moldy or has contaminant	Do cleaning
	The Aperture diaphragm and field diaphragm is not adjusted properly and too much stray light.	Adjust the diaphragm properly
	The objective is not in the	Turn the nosepiece to the

	center of the light path	located position
	Fine focus system is broken	Examine and repair the fine focus system(send to factory for overhauling)
5、 The image focus surface inclines (one side is clear and the other side is faint)	The illumination light inclines seriously	Adjust the filament position ,let the light distributing of the field of view become symmetrical and bright
	The specimen is not placed in required position	Put the specimen in the right position
	The nosepiece is not in the located position	Turn the nosepiece in the required position
6. The eyes are uncomfortable, the left and right fields of view is not coincided	The interpupillary distance is not correct	Adjust the interpupillary distance correctly
	The diopter is not right	Adjust the diopter according your sight
	Can' t adapt to binocular observation	When look into the objective, do not stare at the specimen but at the whole field of view, or move the eyes away to look at other things ,then look into the cypiece again.
II、 Mechanical System		
1.The coarse focus knob is hard to turn	The tension adjustment collar is set too tight	Loose the tension properly
2.The image can't stay on the focal plane in the process of the observation	The tension adjustment collar is set too loose	Tighten the tension properly
III、 Electrical system:		
1、 The lamp can' t light	No power supply	Check the power cord, and connect them exactly
	the installation of the bulb is wrong	Install the bulb correctly
	The bulb burned out	Replace with a new bulb
2、 The bulb burn out in frequently	Not use the specified lamp	Use the required lamp
3、 The brightness is not enough	Not use the specified lamp	use the specified lamp
	The brightness adjustment knob is set too low	Adjust the brightness adjustment knob properly
4、 The light glimpses	The bulb is going to spoil	Change the bulb
	The power cord has a poor contact	Check the power cord, and connect them exactly