

User Manual

Binocular Stereo Microscope

Model $\begin{matrix} V426 \\ XV426 \end{matrix}$ Series



MicroscopeNet.com

Table of Contents

i. Caution.....	1
ii. Care and Maintenance.....	1
1. Component Illustration.....	2
2. Installation.....	3
3. Operation	4
4. Specifications.....	6
5. Troubleshooting Guide.....	7
6. Boom Stand Assembly instructions.....	8
7. Optional Parts.....	9

i. Caution

1. Find the “UP” sign and place the Styrofoam container on your table or bench so that the arrow is pointing upward. Open the shipping carton carefully to prevent any accessory, like eyepieces, from dropping and being damaged.
2. Do not discard the molded Styrofoam container. The container should be retained should the microscope ever requires reshipment.
3. Keep the instrument out of direct sunlight, high temperature or humidity, and dusty environments. Ensure that the microscope is located on a smooth, level and firm surface.

ii. Care and Maintenance

1. Do not attempt to disassemble any component including eyepieces, objectives or focusing mechanism.
2. Keep the instrument clean; remove dirt and debris regularly. Accumulated dirt on metal surfaces should be cleaned with a damp cloth. More persistent dirt should be removed using a mild soap solution. **Do not use organic solvents for cleansing.**
3. The outer surface of the optics should be inspected and cleaned periodically using an air stream from an air bulb. If dirt remains on the optical surface, use a soft cloth or cotton swab dampened with a lens cleaning solution (available at camera stores). All optical lenses should be swabbed using a circular motion. A small amount of absorbent cotton wound on the end of a tapered stick makes a useful tool for cleaning recessed optical surfaces. Avoid using an excessive amount of solvents as this may cause problems with optical coatings or cemented optics or the flowing solvent may pick up grease making cleaning more difficult.
4. Store the instrument in a cool, dry environment. Cover the microscope with the dust cover when not in use.

1 Components Illustration

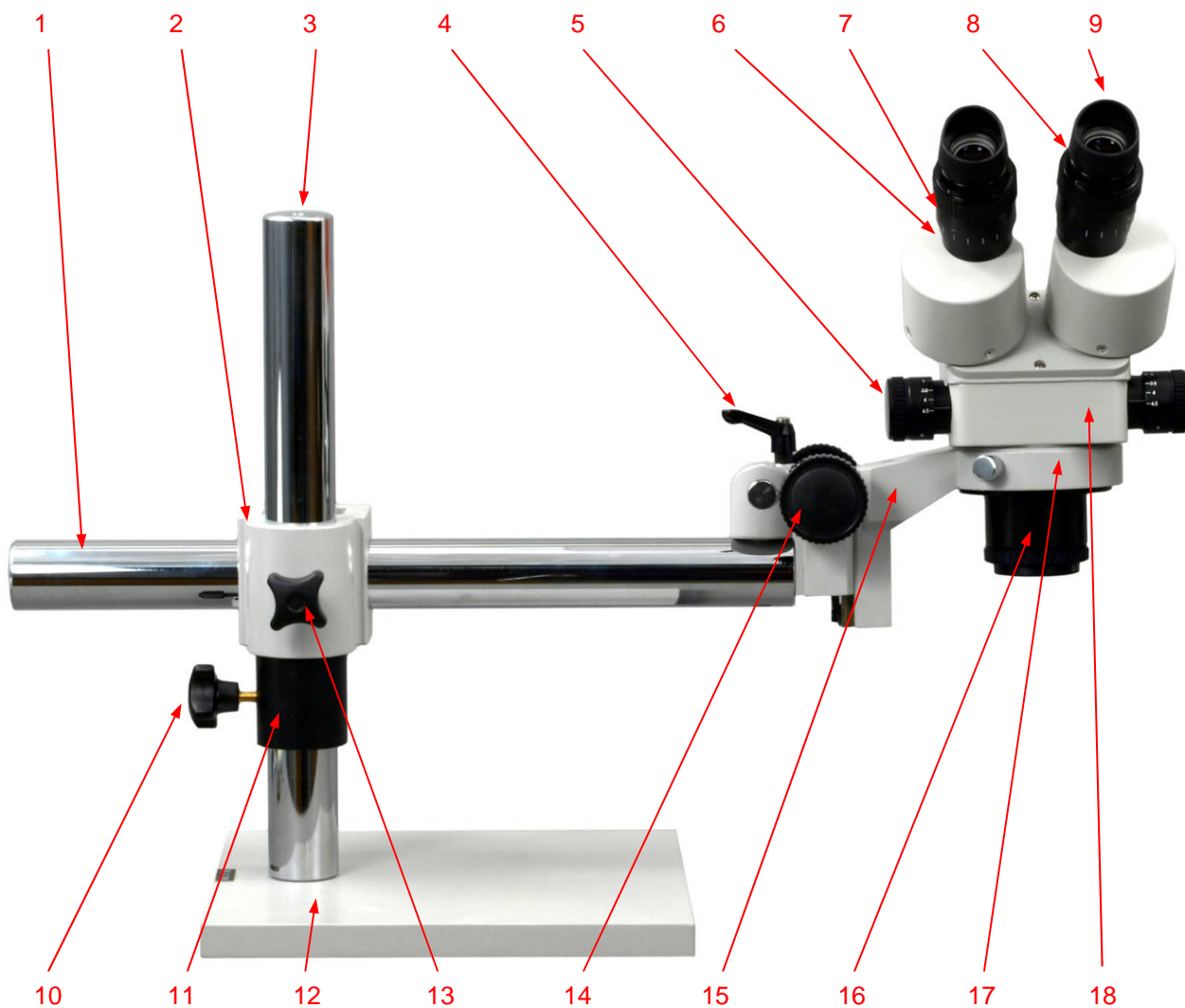

- | | | | | | |
|---|----------------|----|--------------|----|-------------------|
| 1 | Horizontal Bar | 7 | Diopter Ring | 13 | Knob |
| 2 | Bar Adapter | 8 | Eyepiece | 14 | Focus Knob |
| 3 | Stand Post | 9 | Eye Shield | 15 | Focusing Block |
| 4 | Locking Handle | 10 | Knob | 16 | Objective Housing |
| 5 | Zoom Knob | 11 | Post Collar | 17 | Holding Ring |
| 6 | Eyepiece Tube | 12 | Base | 18 | Microscope Body |

2 Installation

2.1 Install the boom stand

See chapter 6.

2.2 Install the microscope body

- 2.2.1 Loosen the thumb screw on the body holding ring.
- 2.2.2 Sit the body into the holding ring firmly.
- 2.2.3 Tighten the thumb screw.

2.3 Install the eyepieces

- 2.3.1 Take off the plastic covers on the eyepiece tubes.
- 2.3.2 Insert the eyepieces into the eyepiece tubes.

2.4 Install the auxiliary lens (optional)

- 2.4.1 Screw off the plastic cover on the bottom of objective housing.
- 2.4.2 Screw on the auxiliary lens onto the objective housing.

Note: The auxiliary lens is optional and may have different color and shape from the one in the picture, depends on the model purchased.

2.5 Install the camera (optional)

- 2.5.1 Take off the eyepiece from the eyepiece tube.
- 2.5.2 Insert the 30.0mm adapter into the eyepiece tube.
- 2.5.3 Insert the camera into the eyepiece tube which with 30.0mm adapter on, and then connect the camera to a computer by a USB cable.
- 2.5.4 Refer to the manual in the Camera CD to installation the driver and software.

Note: The camera is optional and may have different color and shape from the one in the picture, depends on the model purchased.

2.6 Install the ring light (optional)

- 2.6.1 Screw off the plastic cover on the bottom of objective housing.
- 2.6.2 Screw on the ring light adapter onto the objective housing.
- 2.6.3 Put the ring light on to the ring light adapter. Tighten the 3 screws. Make sure the end of the screws stick into the groove of the adapter.

Note: The ring light is optional and may have different color and shape from the one in the picture, depends on the model purchased.



Thumb Screw
Holding Ring

Auxiliary Lens



Camera
Eyepiece Tube



Ring Light Adapter

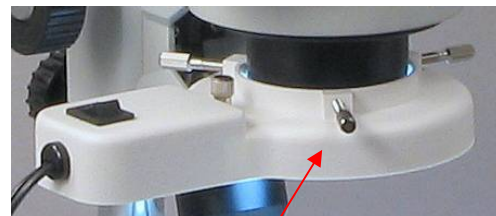

Ring Light

3 Operation

3.1 Adjust the boom stand

- 3.1.1 Loosen the knob on the stand collar and slide it down to the base.
- 3.1.2 Loosen the knob on the bar adapter and slide the horizontal bar up or down so that the distance between the objective and the specimen surface is about 95mm (with no auxiliary lens) or 150mm (with 0.5X auxiliary lens on). And then tighten the knob.
- 3.1.3 Slide the post collar to against the focus block as showed in the figure, and then tighten its knob.



3.2 Adjust the focusing block

- 3.2.1 Loosen the thumb screw on the holding ring to swivel the microscope body 360 degrees.
- 3.2.2 Loosen the locking handle on the focusing block to tilt the focusing block from 0 to 130 degrees.
- 3.2.3 Loosen the knob to rotate the focusing block.
- 3.2.4 With the combination of the above adjustments, it's possible to observe the specimens in almost any directions.



Knob

3.3 Focusing

- 3.3.1 Turn the zoom knob at 0.7.
- 3.3.2 Turn the focus knob until the specimen is in focus.
- 3.3.3 Move the interesting spot of specimen into the center of field of view.
- 3.3.4 Turn the zoom knob for the desired magnification.
- 3.3.5 Adjust the focus knob slightly to get clear image.

3.4 Adjusting interpupillary distance

While observing with both eyes, hold the left and right eyepiece tubes and swing inwards or outwards. The interpupillary distance is correct when the left and right fields of view converge completely into one image.



3.5 Adjusting eyepiece diopter

- 3.5.1 Turn the diopter rings on both eyepiece tubes at 0 positions.
- 3.5.2 Using your right eye only, observe your specimen through the right eyepiece and bring it into focus by adjusting the focus knob.
- 3.5.3 Then observe the specimen with your left eye only through the left eyepiece. If the specimen is not in focus, rotate the diopter ring until a sharp image is obtained.



3.6 Adjust the ring light (optional)

- 3.6.1 Install the ring light, and connect the AC adapter to the power outlet.
- 3.6.2 Turn on the power button on the ring light.
- 3.6.3 Adjust the intensity dial.

3.7 Camera (optional)

- 3.7.1 Install the camera following the procedures in 2.5.
- 3.7.2 Focus the microscope following the procedures in 3.3.
- 3.7.3 Open the software of the camera and launch the live view window.
- 3.7.4 If the live view image is not in focus, adjust the focus knob slightly till the image displayed on the screen is in focus.
- 3.7.5 You can observe image, snap picture, and capture video in the software.

Note: Please refer to the User Manual in the Camera CD for the software operation.

4 Specifications

Model	V426/XV426 Series
Microscope body	Binocular, 45° inclined, 360° swiveling. Adjustable Interpupillary distance 55 ~ 75mm (2-3/16" ~ 2-15/16") Adjustable diopter on both eyepiece tube ±5dp
Eyepieces	1 pair of WF10X, 1 pair of WF20X (optional)
Objectives	Zoom 0.7x ~ 4.5x, ratio 6.5:1 Auxiliary lens 0.5X (optional)
Focusing Mechanism	Rack and pinion, focusing knobs on both sides
Working Distance	95 mm (3-3/4") with no auxiliary lens 152 mm (6") with 0.5X auxiliary lens on
Boom Stand	Horizontal bar total length: 61cm (24") Max. height: 38.5cm (15-1/8") Base dimension: 25cm x 25cm (10" x 10")
Illumination	Ring light (optional) Cold light (optional)
Dimension	66cm x 25.4cm x 40.5cm (26" x 10" x 16")
Net weight	18.2 kg (40 lb)

5 Troubleshooting Guide

Symptom	Cause	Remedy
Totally dark in the view field	The cover of objectives is still on	Take off the cover of objectives
Stains or dust on the field of view	Stains or dust on the eyepieces or objectives	Clean the lens with a camera cleaning kit
	Stains or dust on the specimen	Clean the specimen
Can not focus	The focus block/objectives is too far away or too close to the specimen and out of the range of focus stroke	Adjust the height of the focusing mechanism so that the distance between the objectives and specimen is about 95mm (with no auxiliary lens) or 152mm (with 0.5X auxiliary lens on).
Image moves while focusing	Specimen rises from stage surface	Secure the specimen

6 Boom Stand Assembly instructions

6.1 Put the boom stand base on a firm and sturdy table or level surface.

6.2 Mount stand post onto boom stand base.

6.2.1 Take off the screw at the bottom end of stand post.

6.2.2 Insert the post screw into the hole on the base from underneath.

6.2.3 Tighten the screw with the Allen key as shown in the figure.

6.3 Mount post collar onto the post

6.3.1 Slide the post collar over the vertical post.

6.3.2 Install and tighten the locking knob.

6.4 Mount the bar adapter

6.4.1 Slide the adapter over the stand post, till touches the post collar.

6.4.2 Install and tighten the knob.

6.5 Mount the horizontal bar

6.5.1 Insert the horizontal bar into the bar adapter. Make sure the long flat slot surface on the bar align to the knob screw hole.

6.5.2 Install and tighten the knob

Note: The mounting holes on each end of the horizontal bar are different. It depends on how you would like to install the focusing block to put which end on right side and which on left side.

6.6 Mount the focusing block onto the horizontal bar (the end with axial hole)

6.6.1 Insert the shaft of focusing block into the axial hole on the end of horizontal bar.

6.6.2 Install and tighten the knob.

6.7 Mount focusing block onto the horizontal bar (the end with vertical hole)

6.7.1 Insert the shaft of focusing block into the vertical hole on the other end of horizontal bar.

6.7.2 Install and tighten the knob.



6.2



6.3

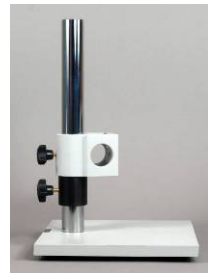

6.4



6.5



6.6









6.7

7 Optional Parts:

(The optional parts may be included in some models or sold separately.)





7.1.1 Camera

	Model	Resolution	Operating System	Software
	A1502	640 x 480 (0.3MP)	MS Windows (32/64bit)	Included
	A1510	1280 x 1024 (1.3MP)		
	A1520C	1600 x 1200 (2.0MP)		
	A1530	2048 x 1536 (3.0MP)	MS Windows (32bit)	
	A1550	2592 x 1944 (5.0MP)	MS Windows (32/64bit)	
	A1590	3488 x 2616 (9.0MP)		

7.1.2 Illuminator

	Model	Lamp
	A12CR	Halogen 21V/150W Fiber Cold Ring Light
	A12CY	Halogen 21V/150W Fiber Cold Y Light
	A9208	8W Fluorescent Ring Light
	A9212	128W Fluorescent Ring Light
	A9239	39 LEDs Macro Ring Light
	A9254 A9254P	54 LEDs Macro Ring Light
	A9264S	64 LEDs Macro Ring Light
	A92144B	144 LEDs Macro Ring Light
	A92144L	144 LEDs Macro Ring Light
	A92144S	144 LEDs Macro Ring Light

7.1.3 Auxiliary Objective Lens

	Model	Magnification
	AJ5D3AUX	0.3X
	AJ5D5AUX	0.5X
	AJ5D75AUX	0.75X
	AJ5X2	0.2X