

# TRANQUILITY® DIGITAL OUTDOOR SPLIT (TEP)

The Tranquility® Digital Outdoor Split Geothermal Heat Pump delivers the ULTIMATE in efficiency (25.6 EER and 4.3 COP\*), comfort, reliability and serviceability – intelligently driven by the iGate™, the industry's first two-way communicating control, two-stage compressor, and industry-first vFlow™ internal variable water flow components. The Tranquility® Splits also deliver reliable operation, lower operating costs and compact installation.

The Tranquility® Digital Outdoor Split Series easily connects to new or existing fossil fuel and electric furnaces. Designed for the replacement market, quiet outdoor installations with weather and sound insulated cabinets make it the perfect fit. Includes built-in earth loop circulating pump, flushing valves, expansion tank and hose kit for easy ground loop connection.



**vFlow**  
Variable Water Flow

**iGate**  
monitor. control. diagnose.



## Features

- 1 Exclusive iGate™ uses the power of 2-way communication to monitor, control and diagnose your system. It improves system life by monitoring and protecting the unit and delivers high efficiency by intelligently controlling the unit.
- 2 vFlow™ Variable Water Flow with Variable-Speed Internal Flow Center for optimized efficiency, reliability and quicker, easier, cleaner installation
- 3 Next generation Copeland™ Ultra-Tech™ Two-Stage Scroll Compressor with dual-level isolation for ultra-quiet and high-efficiency operation
- 4 Fully Insulated Water and Refrigerant Lines
- 5 Large Easily Accessible Control Box
- 6 Backseating Brass Service Valves with Service Port
- 7 Stainless Steel Braided Hoses for Easy Connection to Loop Piping

## Application Flexibility

- Four Capacities 026, 038, 049, and 064
- Entering water temperature operation range 20–120°F
- iGate™—Monitor, control and diagnose digitally from the thermostat
- vFlow™—Connect geo source directly to the loop
- Ground loop and water loop applications
- AHRI matched and rated with TAC and TAH products
- Can be used as a total electric heat pump or add on heat pump with fossil fuel backup
- Indoor models available (TES)
- Standard 10-year limited warranty on all parts with 5-year labor allowance; Optional extended 5-year limited labor allowance available

**CLIMATEMASTER®** GEOTHERMAL HEATING AND COOLING  
DECLARE YOUR PERSONAL ENERGY INDEPENDENCE

# Tranquility® Digital Outdoor Split (TEP) Series

## Performance and Specifications

### Tranquility® TEP ISO Ratings

AHRI/ISO/ASHRAE 13256-1 Data (English (IP) Units)

Model	Water Loop Heat Pump				Ground Water Heat Pump				Ground Loop Heat Pump			
	Cooling 86°F		Heating 68°F		Cooling 59°F		Heating 50°F		Full Cool 77°F Part Cool 68°F		Full Heat 32°F Part Heat 41°F	
	Capacity Btuh	EER Btuh/W	Capacity Btuh	COP	Capacity Btuh	EER Btuh/W	Capacity Btuh	COP	Capacity Btuh	EER Btuh/W	Capacity Btuh	COP
*TEP/P026 Part	18,000	16.4	23,200	5.7	20,400	27.8	18,700	4.8	20,300	24.0	15,300	4.0
*TEP/P026 Part	23,200	14.9	29,200	4.9	25,600	22.4	24,900	4.5	25,800	17.7	18,800	3.6
**TEP/P*026 Part	19,200	18.3	20,700	5.6	21,500	30.9	17,700	4.9	20,700	25.6	15,500	4.3
**TEP/P026 Full	25,000	16.1	25,300	4.7	27,300	24.0	22,800	4.4	25,800	18.3	18,700	3.8
TEP/P038 Part	26,000	17.3	28,300	5.7	28,800	29.7	23,700	4.8	27,900	24.7	21,000	4.3
TEP/P038 Full	37,000	16.1	37,800	4.9	40,500	23.4	32,700	4.5	37,700	17.8	26,200	3.8
TEP/P049 Part	35,800	16.5	42,000	5.4	40,700	29.4	34,300	4.6	39,100	23.8	29,600	4.0
TEP/P049 Full	46,900	15.0	56,000	4.7	52,800	23.0	45,900	4.2	48,700	16.9	35,900	3.5
TEP/P064 Part	43,400	15.8	52,000	5.2	48,100	26.0	41,700	4.3	45,500	21.7	35,900	3.8
TEP/P064Full	56,800	14.0	67,300	4.4	62,400	20.3	56,600	4.0	57,300	15.5	44,300	3.4

Cooling capacities based upon 80.6°F DB, 66.2°F WB entering air temperature  
 Heating capacities based upon 68°F DB, 59°F WB entering air temperature  
 Ground Loop Heat Pump ratings based on 15% methanol antifreeze solution  
 All ratings based upon operation at lower voltage of dual voltage rated models  
 and when mated with TAH Air Handler.

\*w/17" wide coil  
 \*\*w/21" wide coil

### Tranquility® Digital Outdoor Split (TEP) Dimensional Data

Capacity		Cabinet		
		A Width	B Depth	C Height
TEP026	in	26.3	37.4	29.1
	cm	66.8	95.0	73.9
TEP038	in	26.3	37.4	29.1
	cm	66.8	95.0	73.9
TEP049	in	26.3	37.4	29.1
	cm	66.8	95.0	73.9
TEP064	in	26.3	37.4	29.1
	cm	66.8	95.0	73.9

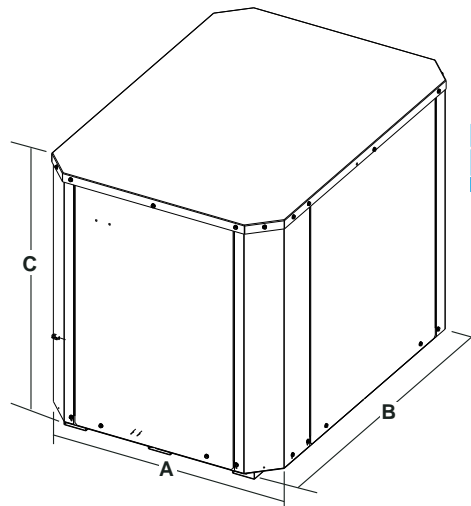

7300 S.W. 44th Street  
 Oklahoma City, OK 73179  
 Phone: 405-745-6000  
 Fax: 405-745-6058  
 climatemaster.com | cmdealernet.com



ClimateMaster works continually to improve its products. As a result, the design and specifications of each product at the time for order may be changed without notice and may not be as described herein. For specific information on the current design and specifications go to cmdealernet.com. Statements and other information contained herein are not express warranties and do not form the basis of any bargain between the parties, but are merely ClimateMaster's opinion or commendation of its products.

Engineered and Assembled in the USA