



Gas Heating/Electric  
Air Conditioning System

UP TO  
**13** SEER2  
.4

81% AFUE



**WELL-BUILT**

*since 1914*

SINCE 1914, WE'VE BEEN DELIVERING ON OUR PROMISE TO CREATE SENSIBLE, AFFORDABLE PRODUCTS THAT DO WHAT YOU NEED THEM TO WHEN YOU NEED THEM TO. BECAUSE THE BOTTOM LINE IS THAT YOU JUST NEED HEATING AND COOLING FOR YOUR HOME - A COST-EFFECTIVE SYSTEM TO KEEP YOU COMFORTABLE. HOMEOWNERS WHO CHOOSE PAYNE ARE DELIGHTED IN THEIR DECISION BECAUSE IT IS SUCH A SENSIBLE CHOICE THAT SAVES THEM MONEY AT THE PURCHASE, AND KEEPS PERFORMING SEASON AFTER SEASON.



*Right for you.*

## OUR PROMISE

### *The Well-Built Warranty.*

*Every packaged comfort system we build is covered with a 10-year parts limited warranty.\* This warranty applies to the original owner of the properly registered product. Heat exchanger carries a 20-year parts limited warranty.*

*Visit [payne.com](http://payne.com) for details.*

## WHAT IS SEER2 and AFUE?2

*Like a car's mpg, SEER2 (Seasonal Energy Efficiency Ratio) is the measure of cooling efficiency for a cooling system. It tells you how much heat is removed from your home in relation to how many watts per hour it takes to reach your set comfort level. To give you an example, the minimum SEER2 level for cooling operation in the U.S. is now 13.4. Payne offers models that exceed that, giving you even better efficiency.*

*AFUE (Annual Fuel Utilization Efficiency) is the measure of fuel efficiency for heating operation. It tells you what percentage of consumed heating fuel, on average, actually goes into heating your home. For example, for each \$1.00 of heating fuel that the Payne PY4G uses, 81% (or \$0.81) is used, on average, to actually heat your home. The higher the number the better, because when you waste energy you waste money.*

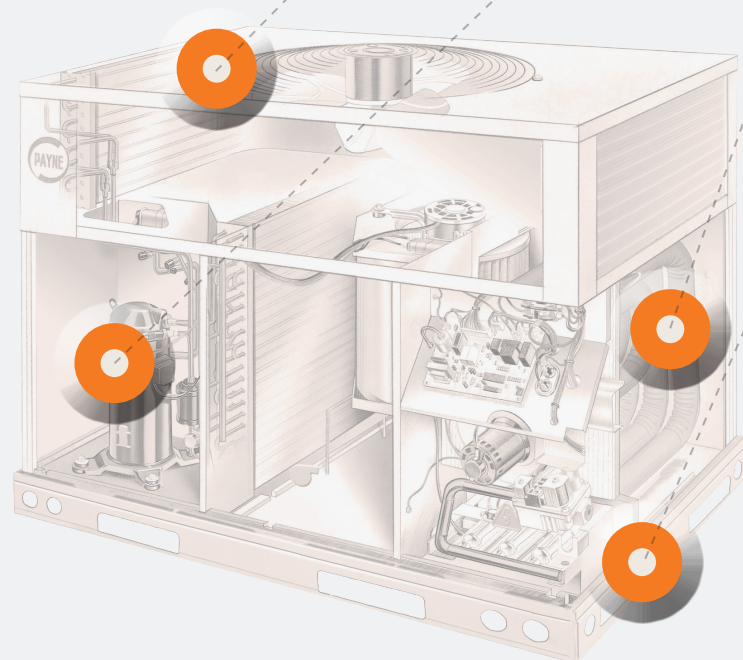

\*Warranty period is 5 years if not registered within 90 days. Jurisdictions where warranty restrictions are not allowed will automatically receive a 10-year parts limited warranty. See warranty certificate at [payne.com](http://payne.com) for complete details, terms and exclusions.

## PACKAGED GAS HEATING/ELECTRIC AIR CONDITIONING SYSTEM

### ENVIRONMENTALLY-SOUND R-410A

This packaged gas heating/electric air conditioning system uses the EPA-approved and chlorine-free R-410A refrigerant, an environmentally-sound alternative to R-22, for minimal effect on the Earth's ozone layer.



**PY4G**

UP TO

**13** SEER2  
.4

81% AFUE

- Ground or rooftop installation
- Single-stage compressor
- R-410A refrigerant
- Aluminum indoor coil

*For homes that are designed to use packaged units, these models have both the interior and exterior components of traditional split-system products combined in one outdoor unit.*

#### For California Residents:

For installation in SCAQMD and SJVAPCD: Model PY4G does not meet the SCAQMD Rule 1111 14 ng/J NOx emission limit.

This product is not eligible for the Clean Air Furnace Rebate Program: [www.CleanAirFurnaceRebate.com](http://www.CleanAirFurnaceRebate.com).

## PEACE OF MIND

*When you purchase Payne products, you will soon find out why they are right for you. Our packaged gas heating/electric air conditioning systems aren't just affordable – they're built to perform. And since packaged systems operate entirely outdoors, all components are designed for durability.*

- 1 Lasting protection** — Exterior cabinetry is coated with a rugged baked-on enamel finish to provide scratch and corrosion resistance. All models utilize an all-aluminum evaporator coil to provide added corrosion resistance.
- 2 Reliable R-410A compressor** — You want the most important part of the entire unit to stay running strong, right? With built-in protective features, our compressor operates quietly and reliably for years of cooling comfort.
- 3 Efficient heating** — Our Turbo-Tubular™ heat exchanger optimizes heat transfer from the unit. Before warm air is delivered to your living spaces, heated gases make multiple passes for increased efficiency. Plus, a tough, corrosion-resistant.
- 4 Solid foundation** — Our durable, composite base features outstanding drainage to help inhibit mold, algae, and bacterial growth. Outside, metal base rails provide added stability, plus easier handling and rigging for the dealer.



## BUY NOW AND PAY OVER TIME\*

A Payne credit card can be an easy and convenient way to pay for your Payne purchases. Plus, as a Payne cardholder you can enjoy special benefits throughout the year, such as:

- Special promotional offers where available
- Open line of credit for all your purchasing needs
- Quick credit decision
- Convenient monthly payments
- Easy online account management

\*Subject to credit approval and additional terms and conditions. Credit card issued by Wells Fargo Bank, N.A.



Visit our website at [payne.com](http://payne.com)  
©2023 Carrier. All Rights Reserved.

*Logos are the registered trademarks of their respective owners.*

*Before purchasing this appliance, please read the important energy cost and efficiency information available from your dealer.*

*Manufacturer reserves the right to discontinue, or change, at any time, specifications or designs without notice and without incurring obligations.*

A Carrier Company

