

Slant/Fin

INTREPID

World class oil-fired boilers

**Your best choice for home heating
comfort, reliability and energy savings.**



- Up to 86% Efficiency
- Swing open and removable door
- Top cleaning for easy service
- .75 to 3.10 GPH firing rate
- Cast-iron, wet base heat exchanger
- Hot water and steam models, with domestic hot water coil option
- Low draft loss

***Intrepid is one of the world's
best oil-fired boilers.***

Advanced design ensures superb performance, even during extreme seasonal operating conditions.

Intrepid represents years of research and development, aimed at producing a boiler that would perform with efficiency and reliability, even during seasonal extremes that threaten the performance of ordinary boilers. Intrepid can reduce your fuel bills by up to 30% or more, while providing years of dependable service.

The contoured shape of Intrepid's combustion chamber is computer-designed to support stable combustion. The uniquely configured heat exchanger has one of the lowest draft losses in the industry. Burners are configured for each specific model to provide smooth, clean, efficient operation, unaffected by reduced draft, low oil temperature or low air temperature.



www.slantfin.com



Look for our
Hydronic Explorer app on
iTunes and Google Play!
(Works on iPad, iPhone & Android devices)

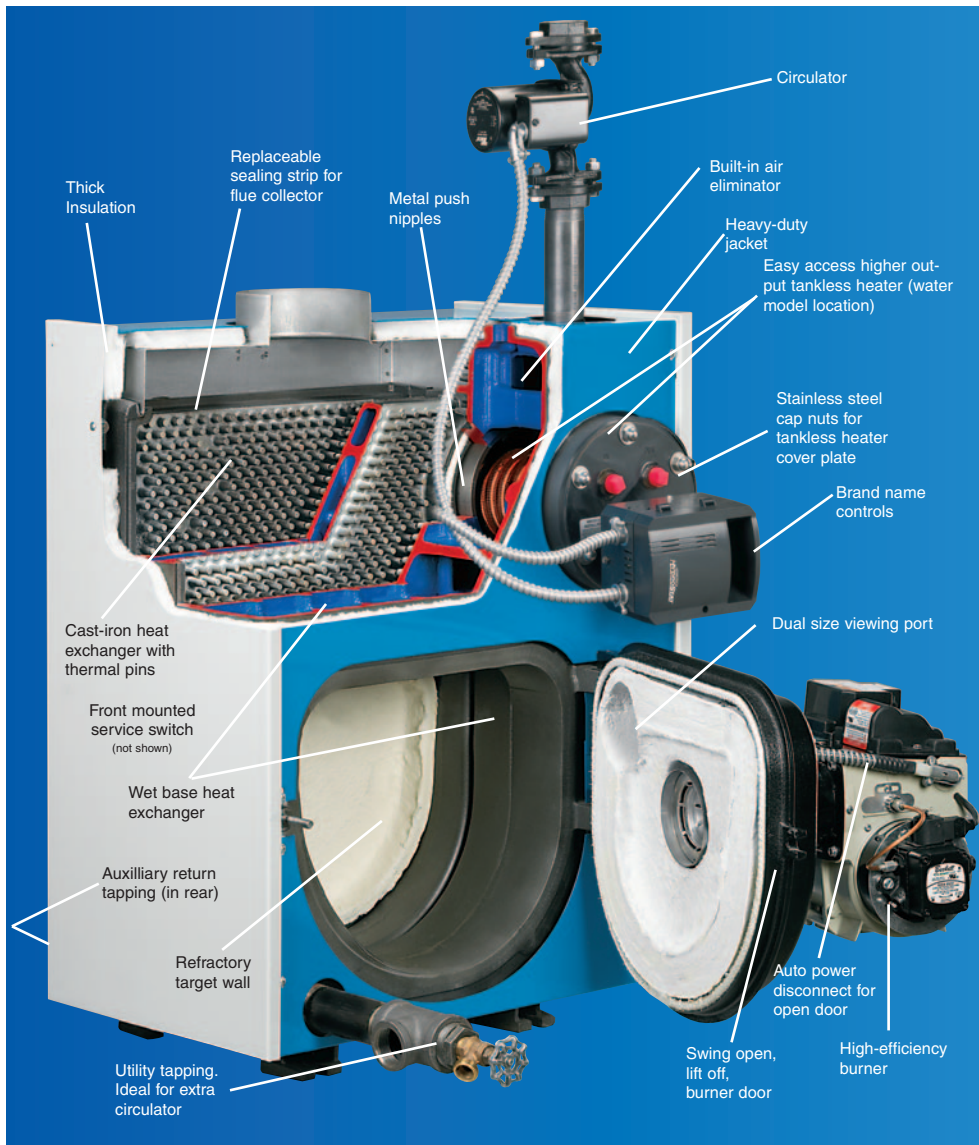

Lifetime limited warranty.

The Intrepid boiler is engineered and built for a long, dependable life. Hot water models are covered under Slant/Fin's lifetime limited warranty. Steam models have a limited ten-year warranty. Contact Slant/Fin for details.

Standard working pressure 30 PSI water, 15 PSI steam.
All boilers hydrostatically tested — A.S.M.E.

- P Packaged water boiler less tankless heater
- PT Packaged water boiler with tankless heater
- PPT Packaged water boiler with provision for tankless heater
- PZ Packaged steam boiler less tankless heater
- PZT Packaged steam boiler with tankless heater

*All packaged boilers are equipped as shown in Standard Equipment chart. In addition, the following models are provided with a blanket in the combustion area: water models TR-60 and TR-70; steam models TR-30, TR-40, TR-50, TR-60 and TR-70.

OPTIONAL EQUIPMENT

Two-stage fuel pump.
Choice of alternate brand circulators and burners.

STANDARD EQUIPMENT	P	PT	PPT	PZ	PZT
Assembled sections	x	x	x	x	x
Jacket with insulation	x	x	x	x	x
Target wall *	x	x	x	x	x
Pressure and temperature gauge	x	x	x	—	—
Pressure relief valves (ASME), in carton	x	x	x	x	x
Flame retention oil burner with nozzle, primary relay and cadmium sulfide flame detector	x	x	x	x	x
Draft regulator, in carton	x	x	x	x	x
Circulator: 1 1/4" (TR-20 thru TR-40) 1 1/2" (TR-50 thru TR-60) (No circulator supplied with TR-70)	x	x	x	—	—
Drain cock, in carton	x	x	x	x	x
Flue brush, in carton	x	x	x	x	x
Combination hi-limit control and circulator relay (TR-20 thru TR-60)	x	—	x	—	—
Tankless water heater	—	x	—	—	x
Provision for tankless water heater	—	—	x	—	—
Cover plate instead of tankless heater	—	—	x	x	—
Combination hi and low limit control, circulator relay (TR-20 thru TR-60)	—	x	—	—	—
Hi and low limit control (TR-70)	—	x	x	—	—
Hi-limit control (TR-70)	x	—	—	—	—
Pressuretrol with siphon, in carton	—	—	—	x	x
Burner mounting plate with swing out door	x	x	x	x	x
Burner mounting plate/insulation *	—	—	—	—	—
Inspection door	x	x	x	x	x
Service switch	x	x	x	x	x
Low water cutoff, No. 67 MM PS801, installed	—	—	—	x	x
Steam trim, gauge and glass gauge in carton	—	—	—	x	x
Low limit control	—	—	—	—	x

Intrepid steam boiler



A generous 3" supply tapping on steam models helps produce drier steam, resulting in quieter operation of your steam heating system.

TRDV sealed combustion models



For installations without a chimney, Intrepid TRDV models vent directly to the outdoors. See Pub. No. TRDV-10.

Note: Basic Intrepid TR-Series boilers, described in this literature (Pub. TR-10), are not designed for direct vent applications.

Incomparable Dependability.

There's no better built oil-fired boiler than Intrepid. Heat exchanger sections, for example, are made of only the finest cast iron, finished to exact specifications on automated high precision machining centers. Final assembly of each boiler is performed by hand. Every boiler section is tested under pressure at least 8 times the normal residential operating pressure. Repetitive testing—individual sections, assembled heat exchanger and completed boiler, ensure the leak-free integrity of every boiler shipped.

Advanced design boiler sections minimize soot buildup.

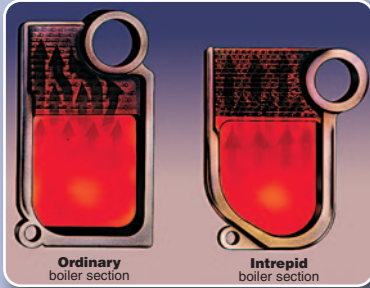

Intrepid's push nipples are located to the side, out of the way of the flue gases. This unobstructed flue passage creates more uniform heat transfer, minimizes draft loss and reduces soot build-up.

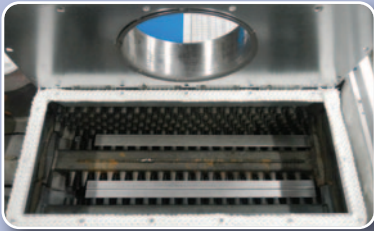

Cleaning is a snap with our new hinged flue collector! Our snap hinges make it super easy to open and reseal. It's easy to reach all of the heat exchanger surfaces with a flue brush for routine cleaning. Swing out door opens for easy servicing.

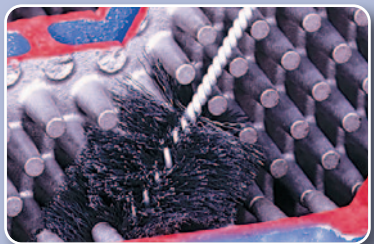

Intrepid allows for easy cleaning.

Burner performance optimized for each specific model. Every burner factory tested.

The burner for each Intrepid boiler is custom manufactured to Slant/Fin specifications. It is engineered to provide smooth, clean, efficient operation under all job conditions. For reliability, every burner is factory test fired before shipping for optimal performance. Final adjustments are easily made by the installer.

For dependability, metal push nipples; name brand controls and circulator pump.

Slant/Fin uses only metal push nipples that expand and contract with the individual boiler sections that they connect. No rubber gaskets. That could result in water leaking from the boiler. Dependable performance is further ensured with nationally known brands of controls and circulator pumps.

Installation is faster, service is easier with these special Intrepid features.

Intrepid's compact size and removable burner door allows it to fit through doors and stairwells with ease. A strong wooden crate protects the Intrepid from factory to basement. Packaged models come pre-wired with the burner mounted, ready for final setup. Controls are mounted up front for easy access. The circulator is prewired and bolted to the skid for shipping. Wiring is long enough for supply side or return mounting. For your convenience, all models include front and rear return tapings.

Burner door swings open, lifts off.

Intrepid's extra large door swings open for routine servicing. It also lifts off, making it easy to fit the boiler through tight spaces and down stairs.

Easy access, higher output tankless heater coil.

Tankless cover plate is mounted on cast-iron extended flange. Stainless steel bolts and cap nuts permit easy removal of seal or coil. Deeper well accommodates longer coil to maximize output of domestic hot water.

Advanced Multi Function Control with Built-in Features:

- Simple to use and set-up
- Boiler Temperature Control • Low Water Cut-Off
- Fuel Saving Boiler Reset • Operating Indicators
- Prioritizes Domestic Hot Water

Standard combination high and low limit with circulator relay control features built-in for the TR-20P/PT thru TR-60P/PT include:

- Easy to set up, turn dials to adjust
- Easy to read LED display and indicators lights
- Safety water temperature High Limit
- Energy Saving water temperature targeting based on boiler demand
- Optional outdoor water temperature reset- just add outdoor sensor
- Low water Cut Off standard- mounted and wired- auto or manual reset
- Easy to adjust, enable or disable low water temp. limit
- DHW priority



Advanced design cast-iron boiler sections

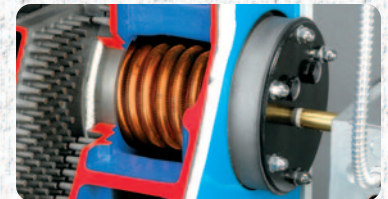

Extended hot water heater coil performs better.



Metal push nipples outperform rubber gaskets.



Easy access to heating coil.

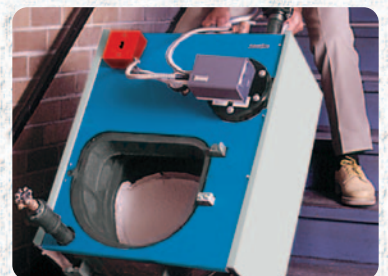

Burner door designed to swing open or lift off.

INTREPID

World class cast-iron oil-fired boilers



Boiler Model No. *	AHRI Burner Capacity Oil Input		D.O.E. Heating Capacity MBH		AHRI Net Ratings			AHRI Chimney Size		A.F.U.E. %		Dimensions (inches)					Boiler Sect.	Tankless Heater GPM **	
	GPH †	BTUH	Water	Steam	Water MBH *	Steam MBH *	Steam Sq. Ft.	Nom. Rect. x Height § (in x in x ft)	I.D. Round x Height (in x ft)	Water	Steam	Boiler Length "A"	Front to Flue "B"	Flue Dia. "C"	Return Circulator Flange "D"	Overall Length "E"		Water	Steam
TR-20	0.75	105,000	89	—	77	—	—	8 x 8 x 15	5 x 15	85.1	—	11½"	8¾"	6"	1¼"	24¼"	2	2.20	—
TR-30H	1.00	140,000	120	—	104	—	—	8 x 8 x 15	6 x 15	86.0	—	14¾"	10½"	6"	1¼"	27¾"	3	3.10	—
TR-30-1.10 ¶	1.10	154,000	131	130	114	98	408	8 x 8 x 15	6 x 15	84.8	84.1	14¾"	10½"	6"	1¼"	27¾"	3	3.20	3.00
TR-30-1.25 ¶	1.25	175,000	149	—	130	—	—	8 x 8 x 15	6 x 15	85.0	—	14¾"	10½"	6"	1¼"	27¾"	3	3.40	—
TR-40H	1.50	210,000	181	176	157	132	550	8 x 8 x 15	7 x 15	86.0	84.0	18½"	11¾"	7"	1¼"	31"	4	3.80	3.40
TR-40-1.60 ¶	1.60	224,000	189	188	164	141	588	8 x 8 x 15	7 x 15	84.4	83.8	18½"	11¾"	7"	1¼"	31"	4	3.90	3.50
TR-40-1.80 ¶	1.80	252,000	218	—	190	—	—	8 x 8 x 15	7 x 15	84.2	—	18½"	11¾"	7"	1¼"	31"	4	4.15	—
TR-50H	2.00	280,000	241	239	210	179	736	8 x 8 x 15	8 x 15	86.0	84.0	21¾"	13¾"	8"	1¼"	34¾"	5	4.30	3.90
TR-50-2.10 ¶	2.10	294,000	247	245	215	184	767	8 x 8 x 15	8 x 15	84.0	83.4	21¾"	13¾"	8"	1¼"	34¾"	5	4.40	4.00
TR-50-2.35 ¶	2.35	329,000	272‡	—	237	—	—	8 x 12 x 15	8 x 15	82.7‡	—	21¾"	13¾"	8"	1¼"	34¾"	5	4.70	—
TR-60-2.60	2.60	364,000	301‡	311‡	262	233	971	8 x 12 x 15	10 x 15	82.7‡	85.5‡	25"	15¾"	8"	1¼"	37¾"	6	4.90	4.50
TR-60-2.75	2.75	385,000	316‡	—	275	—	—	8 x 12 x 15	10 x 15	82.1‡	—	25"	15¾"	8"	1¼"	37¾"	6	5.20	—
TR-70-3.10 ¶	3.10	434,000	358‡	362‡	311	272	1129	8 x 12 x 15	10 x 15	82.4‡	83.3‡	28¾"	16¾"	9"	—	41¾"	7	5.45	5.00

* Add Suffix: (P)Packaged water boiler less tankless heater, (PT)Packaged water boiler with tankless heater, (PPT)Packaged water boiler with provision for tankless heater, (PZ)Packaged steam boiler less tankless heater, (PZT)Packaged steam boiler with tankless heater.

Standard working pressure 30 psi water, 15 psi steam.

All boilers hydrostatically tested — A.S.M.E.

* For forced hot water heating systems where the boiler and all piping are located within the area to be heated, the boiler may be selected on the basis of gross D.O.E. capacity output. The net AHRI output ratings shown are based on an allowance for piping and pickup of 1.15 (water) or 1.33 (steam). D.O.E. capacity gross output is divided by the allowance to obtain net rating. The manufacturer should be consulted before selecting a boiler for unusual piping and pickup requirements such as intermittent system operation, extensive piping, etc.

† Ratings apply to the use of light oil at 140,000 Btu per gallon, and apply only when burner models listed on pages 17-19 of this manual are used, and are properly adjusted to produce 13% CO₂.

§ Nominal clay tile liner dimensions.

** Tankless heater rating based on intermittent draw.

¶ Water boiler models TR-30 and larger may have two firing rates. The boiler is factory shipped at the lower firing rate. To obtain the higher firing rate, refer to the INTREPID boiler installation instructions for the appropriate field adjustments.

‡ AHRI gross output (Btuh) and thermal efficiency.

□ Collar is oblong, will fit 6" diameter nominal connector.

○ This dimension is from the boiler jacket to the center of the flue outlet.

NOTE: All boilers under 300,000 Btuh input are tested and rated for capacity under the U.S. Department of Energy (D.O.E.) test procedures for boilers.

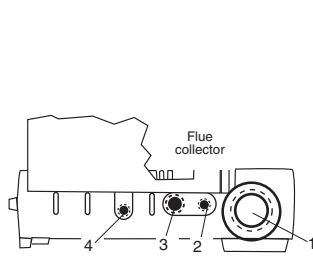

Top view (Front section)

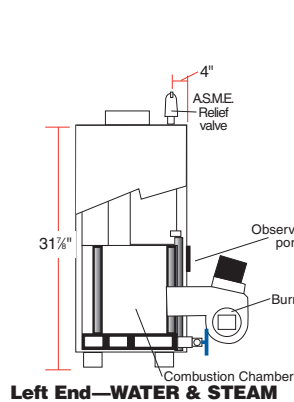

Left End—WATER & STEAM

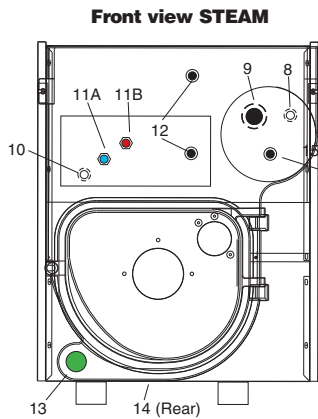
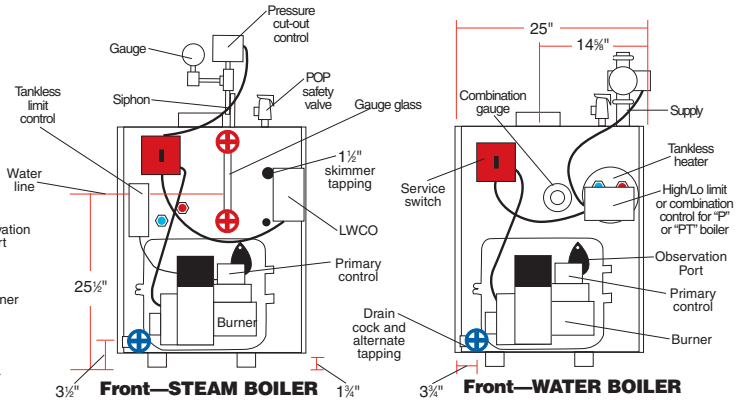

Front view STEAM

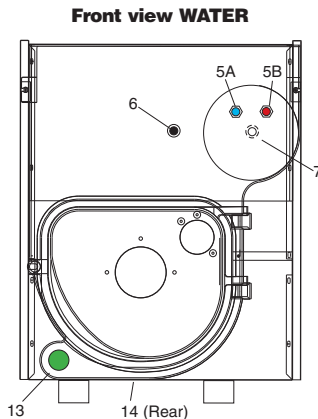

Front view WATER

Tapping Location	STEAM BOILER	WATER BOILER
1	3" supply	1½" supply
1A	2" supply tapping (rear section of L-50, L-60 & L-70 models only)	—
2	Second ¾" siphon, pressure gauge & pressure cut-out	¾" air vent or expansion tank
3	¾" steam safety valve	¾" water relief valve
4	¾" siphon, pressure gauge & pressure cut-out	—
5A	—	¾" tankless inlet
5B	—	¾" tankless outlet
6	—	¾" pressure temp. gauge
7	—	¾" hi limit, hi/lo or comb. control
8	¾" low water cut-off, alternate	—
9	1½" skimmer tapping	—
10	¾" low limit for tankless	—
11A	¾" tankless inlet	—
11B	¾" tankless outlet	—
12	¾" steam gauge glass & 67 PS80L LWCO	—
13	1½" return & ¾" drain cock	1½" return & ¾" drain cock
14	1½" condensate return	1½" alternate return
15	¾" zone tapping	—



©Slant/Fin Corp. 2016 • Printed in the U.S.A. 316 • Publication No. TR-10

SLANT/FIN CORPORATION, Greenvale, NY 11548 • Phone: (516) 484-2600
FAX: (516) 484-0933 • In Canada: Slant/Fin LTD/LTEE, Mississauga, Ontario

www.slantfin.com

