

Sign and display

Bring your ideas to life with Spicers sign and display



Get noticed

About us

Spicers is a leading supplier of wide and grand format printing products encompassing consumables, hardware, software, accessories, training and support. From point-of-sale and vehicle graphics through to exhibition stand construction and shop fit-outs, Spicers has a product to bring your sign and display ideas to life.

With our team of sign and display specialists, Spicers can provide you with information and expert advice. We are your local supplier with stock on the floor and a distribution network ready to deliver to you.

Environment

Spicers is FSC® and PEFC® certified, offers a wide choice of environmentally friendly materials and operates under a Sustainable Supply Chain Policy.

Roll media

Spicers carries your roll media essentials as well as a collection of specialty products to help bring your creative ideas to life. We have media for eco-solvent, UV curable, latex and LED ink technologies. Key brands include 3M™, LG Hausys, dtec™, Yupo®, Photo-Text™ and Digitac.

Spicers offers a range of computer cut colours, wall coverings, banners and repositionable materials to create a unique look and feel.

Rigid media

Spicers supplies a market leading range of essential sign and display substrates, as well as some unique products that stand out from the crowd. Key brands include Yupo®, Corflute®, Skybond™, Ace Screenboard, Ace Outdoor, Komaprint, Foamstar, Palfoam and ARMABoard.

Finishing

If you require essential laminating products to protect your print and extend its longevity, Spicers can help you. Our range includes satin, matt, gloss and specialty anti-graffiti and textured floor graphic products from 3M™ and LG Hausys.

Ink

OEM ink and toner for a vast range of digital wide and grand format printers are part of our offering. These include Mimaki®, EFI™ Vutek, EFI™ Rastek and Roland.

Hardware

Spicers holds a vast portfolio of wide and grand format printing and finishing equipment. We are proud to sell and service machinery from respected brands such as Mimaki™, EFI™, Fotoba International, ROLLSROLLER™, Kala®, Canon, Epson, Elitron and Roland.

Sales and distribution network

Spicers boasts a dedicated sales team and stock on the floor ready to deliver in Melbourne, Sydney, Brisbane, Townsville, Darwin, Perth, Adelaide and Hobart.

Training and technical support

With years of experience, our service and support staff can offer technical guidance and assistance with RIPs, profiling, workflow, maintenance and repairs.

Internal POS, POP and retail solutions

1. Windows

One Way Vision™ films allow stunning graphics on one side and a clear, unobstructed view from the other. Virtually all glass surfaces now have the potential for maximum visual impact.

3M™ Clear Graphic Film 8150 is an optically clear, conformable cast PVC film ideal for glass and clear acrylic where clear vision is required for the unprinted areas of the graphic. Perfect for shop windows.

3M™ ElectroCut™ 7725SE and 5525SE Special Effects Films are medium term, translucent vinyl films for window graphics and internally illuminated displays on flat, clear surfaces.

Yupo® Octopus Clear is an optically clear, removable and reusable self adhesive polyester film that can be reverse printed (UV screen and UV inkjet) and applied to the inside of windows with the graphic facing outwards.

LG Windeco Film is graphic film for windows. It prevents exposure from ultraviolet light, and various embossed patterns with excellent printability. This film provides you with beautiful visual effects on your windows.

2. Walls

Photo-Tex™ is a polyester blend, 95% blackout self-adhesive fabric that will stick to any non-porous surface, walls, windows, doors, columns, poles and so on. With a specially engineered low tack self adhesive that is removable, repositionable and reusable, Photo-Tex is the perfect choice for personalised wall coverings in corporate, retail and home environments.

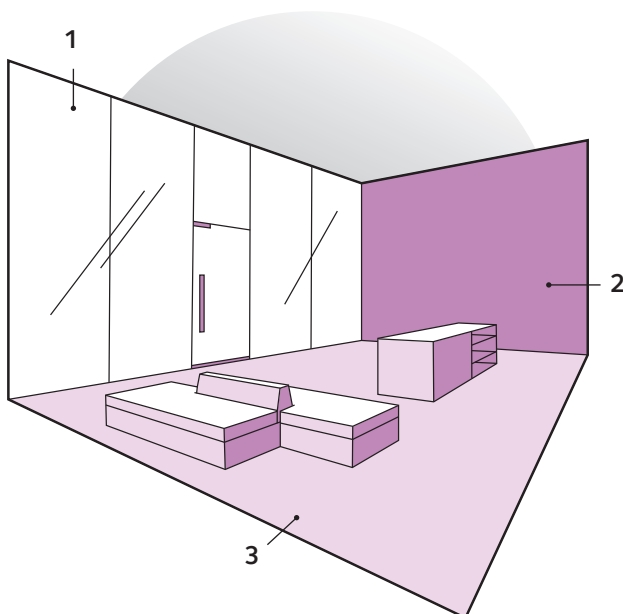

LG LW3850M is a calendered PVC film supplied with removable pressure sensitive adhesive. It's designed for solvent-based inkjet printing and wall graphic application (painted wall, etc). The product is designed to meet high resolution printing with excellent colour.

3M™ High Tack Graphic Film IJ39-20 is ideal for signs and labels on low energy and textured surfaces.

3. Floor

3M™ Graphic Film IJ20-10 with **3M™ Lustre Overlaminates 8509** offer excellent indoor slip resistance for non-wet areas, and the **3M™ Lustre Overlaminates 3645** textured laminate for wet areas.

Digitac Floortac Indoor is matt white, hexagonal textured monomeric vinyl with a grey, airflow, removable adhesive. Requiring no laminate and with a slip rating of R10 simply print and stick for indoor, hard, flat surface floor graphic applications.

LG LP4000 series is a matt PVC over-laminate film for floor graphics protection application. It provides protection from damaging UV radiation, scratch and abrasion. Moreover, it offers enhanced colours and durability.

4. Suspended graphics

Ace Screenboard is a premium, high white, FSC® certified two side display board that can be direct printed or used as a mounting board. Ideal for counter and header cards.

Ace Outdoor is a 100% fibre based display board designed for short term applications in moisture sensitive environments such as freezers and cold rooms.

ARMABoard is a high opacity, light weight, bubble structured polypropylene sheet that is a sustainable replacement to foamed PVC. Perfect for standees and aisle end signage and is 100% recyclable (Code 5).

KomaPrint® and **KomaTex®** are high quality foam PVC sheets for print and fabrication. Available in 1, 2, 3 & 5mm, perfect for indoor and outdoor applications up to 2 years.

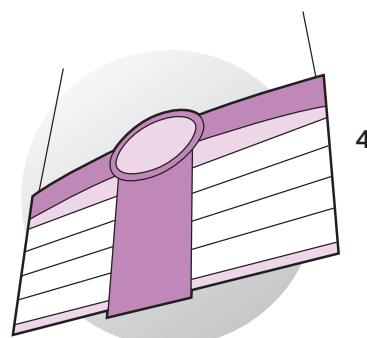

Internal POS, POP and retail solutions

continued

5. Easy install decals

Yupo® Octopus White is a premium polypropylene film that sticks to clean, dry and smooth surfaces using micro-suction technology. Removable and reusable with no residue left behind.

Digitac E-Stat white and clear PVC sticks to smooth, clean and dry surfaces without an adhesive residue. Removable with no residue left behind.

Digitac POP DOT white PVC with unique removable dot adhesive offers quick and easy, bubble-free installation with no need for tools or wet apply installation.

LG SPB014G is a white opaque glossy PVC film for solvent inkjet printing. This is designed to meet high-resolution printing with excellent colour. SPB014G has very low adhesion and no residue after peeling off.

6. Backlit

dtec™ Backlit is a translucent PET film perfect for backlit displays, lightboxes, cosmetic advertising, menu-boards and street furniture.

7. Pullups, posters and banners

dtec™ Poster Paper – light and heavyweight poster papers for eco-solvent, latex, and UV inks.

Echo Matt is a FSC® certified matt coated paper. Echo Matt is available in large format roll and sheet sizes for screen and UV inkjet printing.

Eclipse Blockout Premium is a two side printable, black-centered artboard that promises no show through. Perfect for double sided posters.

dtec™ Pull-up and Poster Films – white blockout PP, grey-back PET and grey-back heavyweight PVC/PET composite films.

dtec™ Banner range incorporates frontlit banners, a light and heavyweight blockout banner and a no scrim blockout banner.

8. Structural POP

Re-board® is a patented rigid paperboard with a unique engineered fluted core. It is incredibly lightweight yet exceptionally strong. Re-board has excellent planar flatness and provides thermal insulation and protection from different environmental conditions. An embedded moisture barrier protects the core and the physical properties remain unchanged in humid conditions. It is durable, contains no harmful components and is form stable. And because it utilises water-based adhesives, Re-board can be recycled as paper in normal waste paper streams.

Corflute® is Australian made, twin-wall polypropylene flute at its best. It is used for short-term display, POS and packaging applications. Available in white and colours Corflute is 100% recyclable (Code 5) – ask us about our recycling program.

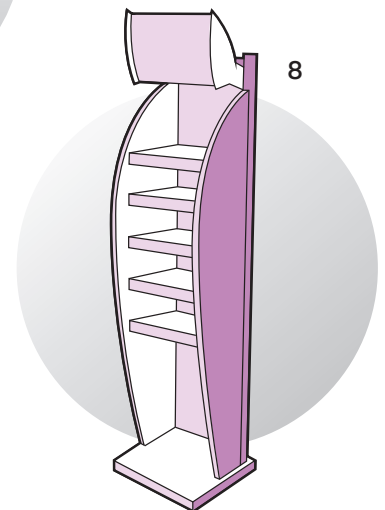
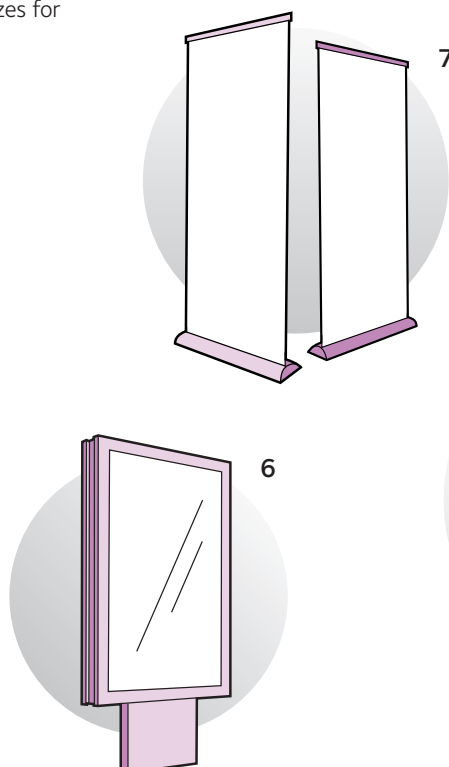

Interior fit-out & architectural finishes

1. Windows

3M Fasara glass finishes transform plain glass, capturing the look of cut or textured glass to an astonishing degree at a fraction of the price.

3M Dichroic glass finishes DF-PA films offer a way to create unique, ever changing colour to interior building surfaces.

One Way Vision™ films allow stunning graphics on one side and a clear, unobstructed view from the other. The perfect window graphic media for vehicle, POP, retail and commercial window signage.

3M™ Scotchcal™ Clear Graphic Film 8150 is an optically clear, conformable cast PVC film ideal for glass and clear acrylic where clear vision is required for the unprinted areas of the graphic. Perfect for shop windows.

3M™ Scotchcal™ ElectroCut™ 7725SE and **Scotchcal™ 5525SE Special Effects Films** are medium-term, translucent vinyl films for window graphics and internally illuminated displays on flat, clear surfaces.

Yupo® Octopus Clear is an optically clear, removable and reusable self-adhesive polyester film that can be reverse printed (UV screen and UV Inkjet) and applied to the inside of windows with the graphic facing outwards

LG Windeco Film is a graphic film for windows that prevents exposure from ultraviolet light. Various embossed patterns and excellent printability provide you with a beautiful visual effect on your windows.

2. Wall covering

Photo-Tex™ is a polyester blend, 95% blockout self-adhesive fabric that will stick to any non-porous surface – walls, windows, doors, columns, poles and so on. With a specially engineered low tack self-adhesive that is removable, repositionable and reusable, Photo-Tex is the perfect choice for personalised wall coverings in corporate, retail and home environments.

3M™ Dinoc architectural finishes resemble natural materials and other types of surfaces to an astonishing degree, delivering the look you want without the weight.

3. Wall cladding

Skybond™ Print is a signage grade aluminium composite panel available in a range of thicknesses and colours, and carries a 10 year warranty. Ideal for both print and fabrication applications.

dtec™ Acrylic is a direct printable cast acrylic that is available in a range of colours and thicknesses. Perfect for illuminated signage, shop fit-outs, exhibitions, and POS.

Traquility Acoustic Board is a unique, direct print lightweight and smooth, 100% polyester fibre compressed sheet. It has excellent sound absorption and thermal insulation properties.

4. Furniture and bulkheads

Re-board® is a patented rigid paperboard with a unique engineered fluted core. It is incredibly lightweight yet exceptionally strong. Re-board has excellent planar flatness and provides thermal insulation and protection from different environmental conditions. An embedded moisture barrier protects the core and the physical properties remain unchanged in humid conditions. It is durable, contains no harmful components and is form stable. And because it utilises water-based adhesives, Re-board can be recycled as paper in normal waste paper streams.

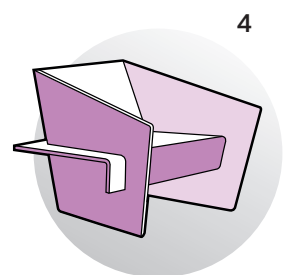
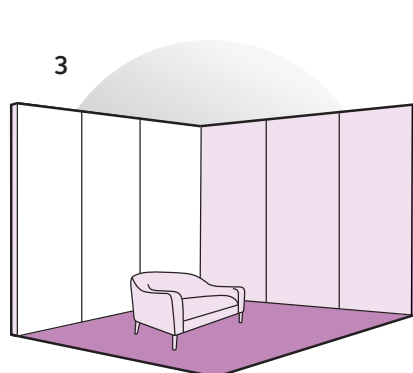
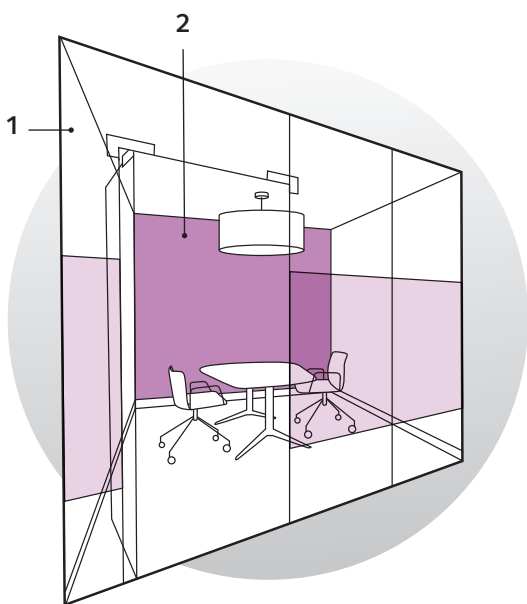

Digital and LED

1. Indoor screens

LG has a range of **LCD**, **LED** and **OLED** screens that will enhance a seamless viewing experience. With space saving super-narrow bezel it delivers a clear image from any angle with an innovative IPS panel. With its extremely attractive and highly functional designs, it can be used to deliver information in a variety of business environments. The **LG Hybrid Cooler**, allows you to display dynamic content on its glass door. When you approach the cooler, the door transforms from translucent to semi-transparent, allowing you to see inside the cooler. It's an effective point-of-sale tool offering greater engagement and delivery of message.

2. Outdoor screens

Dakco offers die-casting aluminum cabinets featuring ultra-light, super slim designs with fast cooling. It provides a complete range of SMD configurations and pitches to suit all viewing distances and sizes. The engineered designs allow for easy maintenance with cabinets designed to be serviced from the front side.

3. Touch screens

LG Overlay Touch KT-T Series is an attachable touch screen that easily changes standard signage products into touch products. With Overlay Touch, your screen will turn into an interactive display which enables smooth writing and drawing experience with ten-point, multi-touch function. This interactivity will bring a new experience into places such as schools, companies, shops and more.

4. LED lights

Rishang RS LED Modules and Ribbons are manufactured from high quality and eco-friendly materials. The flexible LED strips and signage modules are energy efficient and long-lasting – rated IP65 and IP68 for indoor/outdoor applications and offering a 3–5 year warranty. The RS IP68 Power Supply Units are available in 30w to 320w options.

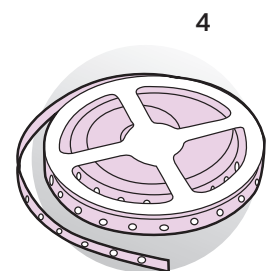
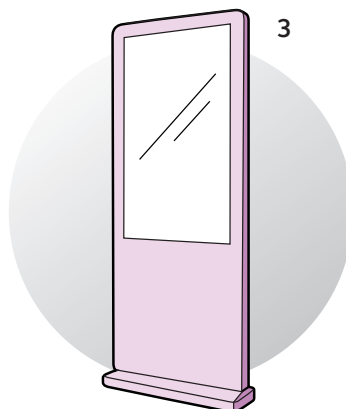
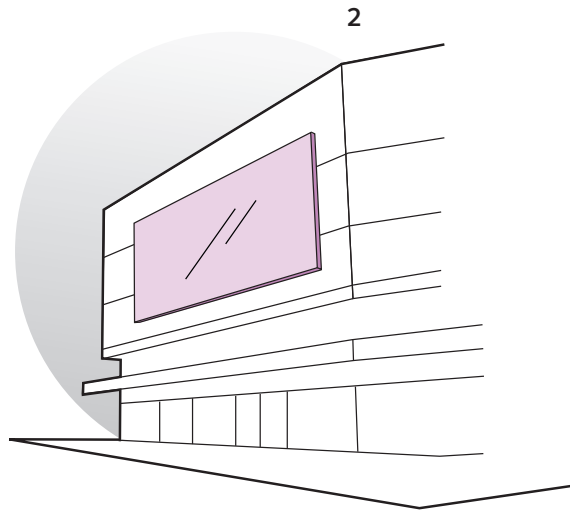
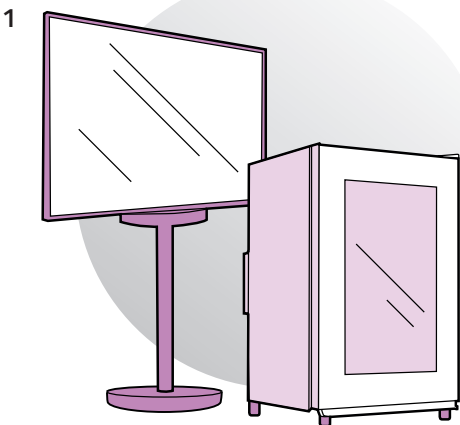

Vehicle graphics and traffic management

1. Vehicle wraps and decals

3M™ Controltac™ Graphic Film with Micro Comply™ Adhesive 180mC, and **3M™ Envision™ Print Wrap Film 480mC** are a series of removable cast digital vinyls that provide excellent conformability to simple and complex curves, rivets, deep corrugations and irregular surfaces. These should always be used in conjunction with the correct matching graphic protection products: **3M™ Overlaminates 8518, 8519, 8520**, and **3M™ Envision™ Overlaminates 8548G, 8549L, 8550M**.

3M™ Removable Reflective Graphic Film with Comply™ Adhesive 680CR is a range of reflective vinyls suitable for emergency vehicles and water craft. It is latex, screen, UV, solvent, and eco-solvent printable. **3M™ Wrap Film Series 1080** paint replacement films are available in a range of 110 colours. Choose from a selection of distinctive finishes: matt, satin, gloss, carbon fibre, straight fibre, flip and brushed metal.

3M™ Removable Reflective Graphic Film with Micro Comply™ Adhesive 780mC is a flexible, enclosed lens, retroreflective available in white only. It has excellent retroreflectivity at wider viewing angles with a pressure-activated adhesive for easy sliding and tacking, snap-up and repositioning. It is flexible, conforms to compound curves, corrugations, and rivets and includes Micro Comply Adhesive for fast, easy bubble-free installations.

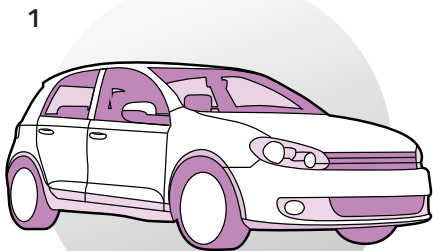

2. Vehicle window graphics

One Way Vision™ films allow stunning graphics on one side and a clear, unobstructed view from the other. Virtually all glass surfaces now have the potential for maximum visual impact. One Way Vision™ is the perfect window graphic media for all types of vehicles.

3. Traffic management

3M™ provide a range of reflectives for traffic control signs including **3M™ High Intensity Prismatic Reflective Sheeting Series 3900 - Class 1**, **3M™ Diamond Grade™ Reflective Sheeting Series 4000 - Class 1**, and **3M™ Engineer Grade Prismatic Sheeting Series 7900 - Class 2**.

4. Vehicle safety reflectives

3M™ Diamond Grade Conspicuity Marking Series 983 are highly retroreflective micro-prismatic markings designed to mark the sides and rear of vehicles for enhanced visibility and detection.

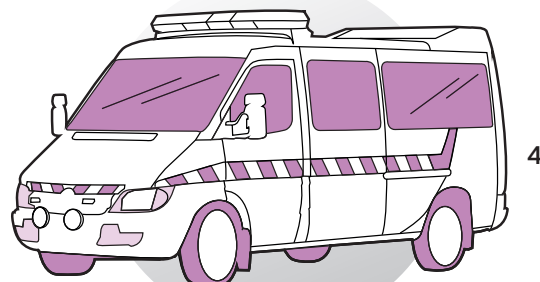
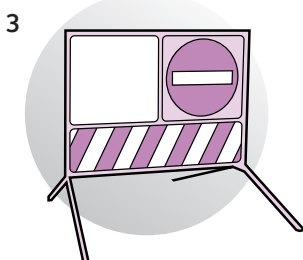
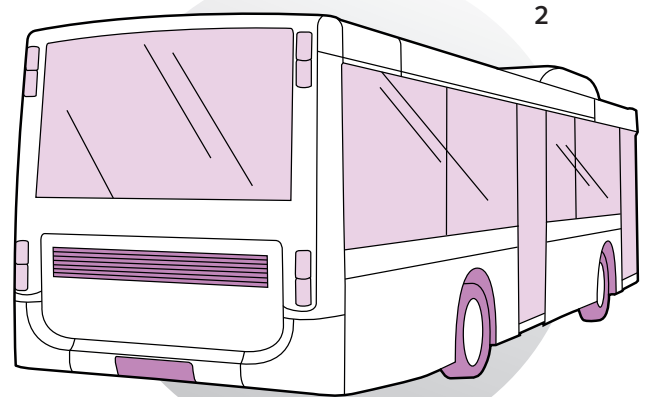

Corporate signage

1. General signage

Skybond™ Print is a signage grade aluminium composite panel available in a range of thicknesses and colours, and carries a 10 year warranty. Ideal for both print and fabrication applications.

KomaPrint® and **KomaTex®** are high quality European manufactured foam PVC sheets suitable for print and fabrication. Available in 1, 2, 3, and 5mm, they are perfect for indoor and outdoor applications up to 2 years.

Corflute® is Australian made, twin wall polypropylene flute at its best. Used for short-term display, POS and packaging applications. Available in white and colours Corflute is 100% recyclable (Code 5) – ask us about our recycling program.

2. Illuminated signage

Rishang RS LED Modules are energy-efficient and long-lasting, rated IP65 and IP68 for indoor/outdoor applications and offering a 3–5 year warranty. The RS IP68 Power Supply Units are available in 30w to 320w options.

dtec™ Acrylic is a direct printable cast acrylic that is available in a range of colours and thicknesses. Perfect for shop fit-outs, signs, exhibitions and POS.

3M™ translucent solutions include: **3M™ Translucent Graphic Film Series 3630** and **3M™ Translucent Graphic Film Series 3730**, with Difuser and Dual Colour Films.

3. Computer cut lettering

3M™ computer cut solutions include: **3M™ ElectroCut™ Graphic Film Series 7725** and **3M™ Controltac™ Graphic Film with Comply™ Adhesive Series 180mC**.

3M™ Opaque Film 50 colour range gives you a comprehensive colour selection for all corporate signage and cut lettering requiring medium to long-term durability.

4. Application tape

RTape Conform® Series with **RLA® Release Liner Adhesion** is guaranteed not to stick together. RTape tears off clean and clear, so graphics lay flawlessly flat with no sticky build up. Available in a variety of tack levels, these products are ideal for all standard sign applications.

ApliTape™ is the original RTape application tape. It has all of the great features of RTape's popular Conform® Series, but without the RLA® Release Liner Adhesion additive. Available in standard and heavyweight paper grades, in a variety of tack levels.

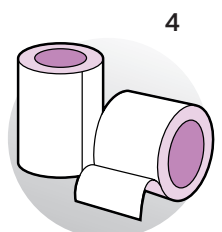
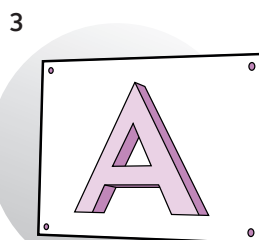
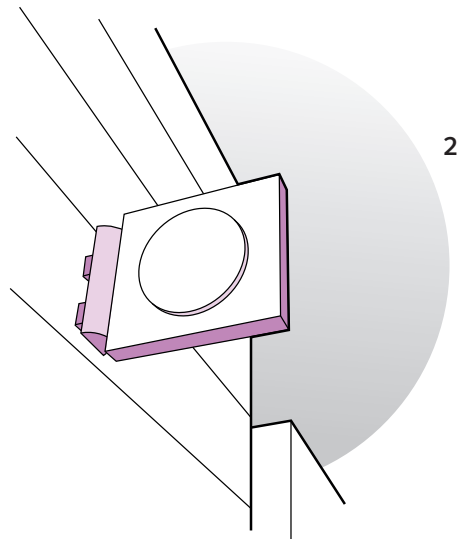

External POS & POP displays

1. Windows

One Way Vision™ films allow stunning graphics on one side and a clear, unobstructed view from the other. Virtually all glass surfaces now have the potential for maximum visual impact.

3M™ Clear Graphic Film 8150 is an optically clear, conformable cast PVC film ideal for glass and clear acrylic where clear vision is required for the unprinted areas of the graphic. Perfect for shop windows.

3M™ ElectroCut™ 7725SE and **5525SE Special Effects Films** are medium-term, translucent vinyl films for window graphics and internally illuminated displays on flat, clear surfaces.

Digitac E-Stat clear PVC that sticks to smooth, clean and dry surfaces without an adhesive residue. Removable with no residue left behind. Perfect for promotional applications.

2. Walls

3M™ Envision™ 480mC is a removable cast digital vinyl that provides excellent conformability to simple and complex curves, rivets, deep corrugations and irregular surfaces. These should always be used in conjunction with **3M™ Envision™ Gloss Wrap Overlaminates 8548G**, **3M™ Envision™ Lustre Wrap Overlaminates 8549L** or **3M™ Envision™ Lustre Wrap Overlaminates 8550M**.

Digitac Floortac Outdoor is a white gloss, deep grain embossed vinyl with an aluminium construction. It is perfect for indoor and outdoor applications on rough wall surfaces such as concrete, asphalt, brick, tiles, marble and terrazzo.

3. Floor

Digitac Floortac Outdoor is a white gloss, deep grain embossed, anti-slip vinyl with an aluminium construction. With an R12 slip rating it is perfect for outdoor applications on rough wall and floor surfaces such as concrete, asphalt, bricks, tiles, marble and terrazzo.

3M™ Scotchcal™ Graphic Film 3662-10 with **3M™ Scotchcal™ Matte Overlaminates 3647** is a textured PVC film for unsealed, exterior, pedestrian surfaces such as concrete and brick pavers. Excellent hiding power and easily removed with little to no residue on unsealed surfaces.

4. Banners

dtac™ Banner range incorporates frontlit banner, light and heavy weight blackout banners and mesh banners.

5. Street furniture

Yupo® FPU, with its market leading whiteness, opacity and colour reproduction is the media of choice for both frontlit and backlit street furniture applications.

6. Real estate

Corflute® is Australian made, twin wall polypropylene fluted sheet. Perfect for direct print or SAV mounted real estate boards.

Skybond™ Print is a signage grade aluminium composite panel perfect for premium real estate boards.

7. Anti-graffiti

3M™ Scotchgard™ Graphic and Surface Protection Film 8993 is an anti-graffiti laminate that protects substrates and surfaces from graffiti, abrasion, stains and UV light. Easy to clean.

8. A-Frames

A-Frames are available in open and closed versions. Perfect for easily transportable indoor and outdoor POS and directional signage.

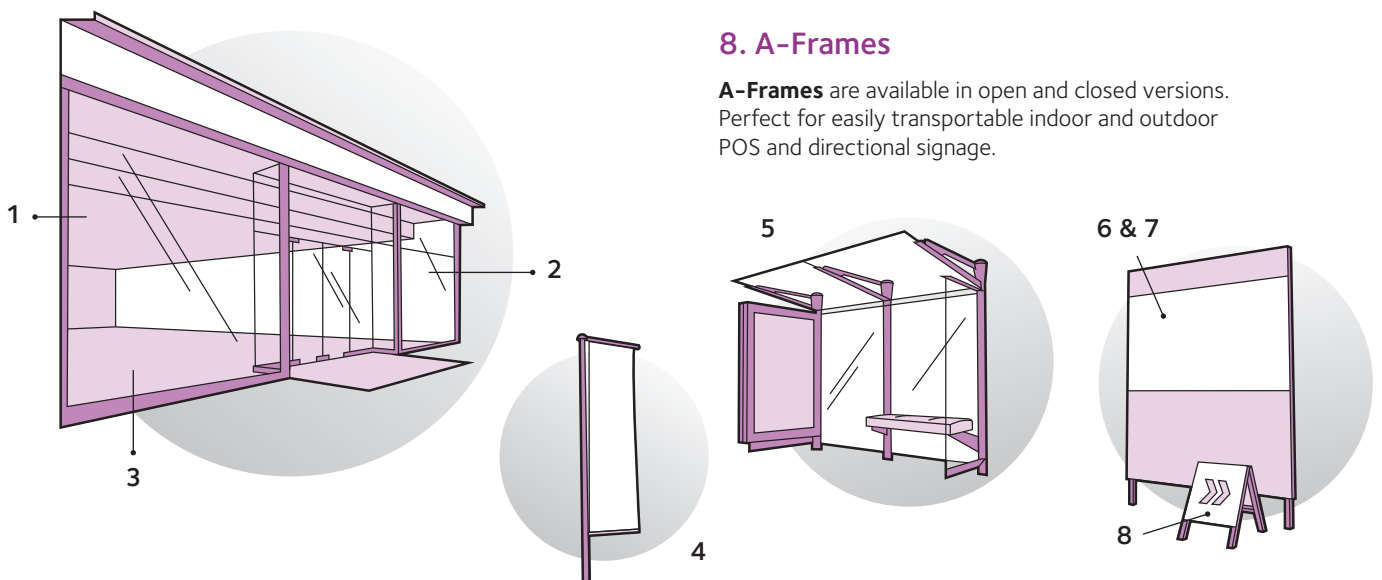



spicers.com.au
1300 132 644

For any product queries please contact your Spicer's representative directly, or your local branch from the list below.

VIC

155 Logis Boulevard
Dandenong South VIC 3175
T (03) 9768 8400
F (03) 9768 8401
info.vic@spicers.com.au

NSW

21 Worth Street
Chullora NSW 2190
T (02) 9735 2666
F (02) 9735 2600
salesnsw@spicers.com.au

QLD Brisbane

Building 5, 441 Nudgee Road
Hendra QLD 4011
T (07) 3084 5200
F (07) 3084 5297
info.qld@spicers.com.au

SA

113 Ledger Road
Beverley SA 5009
T (08) 8243 9393
F (08) 8243 9397
info.sa@spicers.com.au

WA

19 Milly Court
Malaga WA 6090
T (08) 6310 4300
F (08) 9248 6515
info.wa@spicers.com.au

NT

57 Winnellie Road
Winnellie NT 0820
T (08) 8947 0188
F (08) 8947 1366
info.nt@spicers.com.au

QLD Townsville

28A Casey Street
Aitkenvale QLD 4818
T (07) 3084 5200
F (07) 3084 5297
info.qld@spicers.com.au

TAS

4-8 Sunmont Street
Derwent Park TAS 7009
T (03) 6272 5333
F (03) 6272 8103
info.tas@spicers.com.au