



VCU Facilities Management

Design & Construction Standards

Last updated April 9, 2021

Design & Construction Standards

Please Note: This document contains beneficial information on VCU's Design & Construction Standards. It is evolving and subject to change as we continue to define these Standards unique to our University. If you have any comments, additions, and/or corrections to these Standards, please contact Keith Van Inwegen at (804) 828-1204 or email him at kvaninwegen@vcu.edu.

Thank you.

VCU Design & Construction Standards Committee

Beverly Beaver

Director of Facilities Services
VCU Physical Plant
(804) 828-7270
bdbeaver@vcu.edu

Jessica Hurley Smith

Director
VCU Planning & Design
(804) 828-0905
hurleysmitjv@vcu.edu

Joseph Mannix

Assistant Director of Construction Management
VCU Construction and Inspection Management
(804) 827-3842
jgmannix@vcu.edu

Sam Robertson

Director of Physical Plant
VCU Physical Plant
(804) 828-4955
robertsons8@vcu.edu

Keith Van Inwegen

Assistant Director of Design
VCU Planning & Design
(804) 828-1204
kvaninwegen@vcu.edu

Sean Brasch

Mechanical Engineer
VCU Physical Plant
(804) 628-3391
stbrasch@vcu.edu

Matt Magruder

Director
VCU Construction and Inspection Management
(804) 400-8994
magrudermc@vcu.edu

Jaclyn McCormick

Project Manager
VCU Construction and Inspection Management
(703) 929-2350
jmccormick3@vcu.edu

Mike Trzesniowski

Director Engineering & Utilities
VCU Physical Plant
(804) 828-4946
matrzesniowski@vcu.edu

Larry Walters

Director of University Renovations
VCU Construction and Inspection Management
(804) 828-1904
ldwalters@vcu.edu



Design & Construction Standards

Table of Contents

Division 01: General Requirements.....	13
01.01 Design Philosophy.....	13
01.02 General.....	13
01.03 Emergencies, Safety, & Security.....	14
01.04 Special Work Restrictions by Building.....	15
01.15 Traffic / Parking / Work in the Street or Sidewalk.....	17
01.05 Administrative Requirements.....	18
01.06 Construction Site.....	20
01.07 Permits & Shut-Downs.....	21
01.08 Project Completion.....	22
01.09 Sustainable Design Requirements.....	22
01.10 Commissioning.....	22
Division 02: Existing Conditions.....	25
02.10 General.....	25
02.20 Asbestos / Lead Abatement.....	25
02.21 General Project Requirements — Asbestos.....	26
02.22 Asbestos Removal.....	27
02.23 Use of Asbestos or Asbestos Containing Materials.....	28
02.24 Removal & Replacement of Sprayed-On Fireproofing.....	28
02.25 Asbestos Related Work Insurance Requirements.....	29
02.26 Special Procedures for Lead-Containing Materials.....	29
02.27 Resilient Floor Covering.....	31
02.28 Disposal of Hazardous Materials.....	33
02.30 Facilities Management Tree Preservation & Protection Standards.....	72
Division 03: Concrete.....	86
03.1 Concrete Formwork.....	86
03.2 Concrete Reinforcement.....	86
03.3 Cast-in-Place Concrete.....	87



Design & Construction Standards

03.5 Cementitious Decks & Toppings.....	88
Division 04: Masonry.....	89
04.0 General.....	89
04.1 Mortar & Masonry Accessories.....	90
04.2 Unit Masonry.....	91
04.9 Masonry Restoration & Cleaning	92
Division 06: Wood, Plastics, & Composites.....	92
06.0 General.....	92
06.1 Rough Carpentry	93
06.2 Finish Carpentry	93
06.3 Wood Treatment.....	93
06.4 Architectural Woodwork.....	94
Division 07: Thermal & Moisture Protection	94
07.0 General.....	94
07.2 Insulation.....	94
07.3 Steep Slope Roofing	95
07.5 Low Slope Roofing	95
07.6 Flashing & Sheet Metal	96
07.7 Roof Accessories & Specialties	97
07.9 Joint Seals.....	97
Division 08: Openings.....	98
08.0 General Door & Frame Requirements.....	98
08.1 Metal Doors & Frames	99
08.2 Wood & Plastic Doors	100
08.3 Access Doors	101
This standard provides general guidance concerning the specific preferences for access doors and frames for ceilings, floors, and walls.	101
08.4 Entrances & Storefronts.....	102
08.4.2 Automatic Sliding Entrance Doors.....	102
08.6 Roof Windows & Skylights	102
08.7 Hardware, Locks, & Access Control.....	103



Design & Construction Standards

08.7.1 Low-Powered Operators	111
08.8 Glazing.....	111
08.9 Knox Box, First Responder Box & Key Center.....	111
Division 09: Finishes.....	113
09.1 General.....	113
09.2 Plaster & Gypsum Boards.....	114
09.3 Tiling.....	114
09.5 Ceilings	115
09.6 Flooring	115
09.8 Acoustic Treatment.....	116
09.9 Painting & Coating.....	117
Division 10: Specialties.....	117
10.0 General.....	117
10.1 Signage	119
10.2 Toilet Partitions and Stalls.....	120
10.3 Toilet Accessories.....	120
Division 11: Equipment	138
11.0 General.....	138
11.1 Fall Protection	138
11.4 Cold Rooms	140
11.5 Laboratory Equipment	140
11.6 Lockers	141
Division 12: Furnishings	142
12.0 General.....	142
12.9.3 Site Furnishings	142
Division 13: Special Construction	142
13.1 Lactation Rooms.....	142
Division 14: Conveying Systems	144
14.2 Elevators.....	144
Division 18: Sustainability	146
18.0 General.....	146



Design & Construction Standards

18.1 Goal	146
18.2 Sustainable Purchasing Guidelines.....	147
18.3 Solid Waste Management	150
18.4 Pest Management Plan	151
18.5 Heat Island Reduction	151
18.6 Landscape.....	151
18.7 Water Harvesting	152
18.8 Sustainable Building Features	152
18.10 Waste Receptacles	154
Division 21: Fire Suppression	163
21.0 General.....	163
Division 22: Plumbing.....	164
22.0 General.....	164
22.3 Non Metallic Pipe Tracer Wire	165
22.4 Plumbing Fixtures.....	165
22.4.5 Emergency Plumbing Systems	166
22.6 Compressed Air Systems.....	167
Division 23: Heating, Ventilation & Air Conditioning (HVAC).....	174
23.0 General.....	174
23.3 Motors & Variable Speed Drives	176
23.5 Meters & Gauges for HVAC.....	176
23.11 Facility Fuel Piping.....	179
23.20 HVAC Piping & Pumps	180
23.27 HVAC Insulation.....	180
23.28 HVAC Filters.....	181
23.29 Ultraviolet C	181
23.30 HVAC Air Distribution	181
23.50 Meters.....	181
23.57 Heat Exchangers.....	183
23.65 Cooling Towers.....	183
Division 25: Building Automation System (BAS).....	184



Design & Construction Standards

25.0 General.....	184
Division 26: Electrical	186
26.0 General.....	186
26.1 Lightning Protection.....	187
26.2 Outlet & Switch Labels	187
26.3 E Power Switches and Outlets.....	187
26.5 Conductors & Cables	187
26.9 Instrumentation & Controls for Electrical Systems	187
26.20 Low-Voltage Electrical Transmission	188
26.30 Facility Electrical Power Generation and Storing Equipment	189
26.50 Lighting.....	192
Division 27: Communications (Media Support)	193
27.1 General.....	193
27.2 Data Communications	194
27.5 Distributed Communications & Monitoring Systems.....	194
Division 28: Electronic Safety & Security	213
28.0 General.....	213
28.1 Electronic Access Control & Intrusion Detection	214
28.2 Electronic Surveillance	214
28.3 Fire Detection & Alarm.....	214
Division 32: Exterior Improvements.....	216
32.8 Irrigation.....	216

Design & Construction Standards

Terms & Definitions

Integrate — When used in the context of building automation, this means that the system in question will be controlled by the software.

Interface — When used in the context of building automation, this term means that the system in question will communicate with the software, but not necessarily be controlled by it.

Acronyms & Abbreviations

A/E	Architects / Engineers
ABB	ASEA Brown Boveri
ACI	American Concrete Institute
ACMs	Asbestos-Containing Materials
ADA	Americans with Disabilities Act
ADAAS	Assuring Dependability in Architecture-based Adaptive Systems
AFF	Above Finished Floor
AHJ	Authority-Having-Jurisdiction
AHU	Air Handler Units
AMCO	American Meter Company
ANSI	American National Standards Institute
ARR	Association of American Railroads
ASCE	American Society of Civil Engineers
ASHRAE	American Society of Heating, Refrigerating, & Air-Conditioning Engineers
ASME	American Society of Mechanical Engineers
ASSE	American Society of Safety Engineers
ASTM	American Society for Testing & Materials
AWWA	American Water Works Association
BAS	Building Automation System
BCOM	Bureau of Capital Outlay Management
BSCs	Biological Safety Cabinets
BTU	British Thermal Unit
CBSS	Chemical Biological Safety Section
CCTV	Closed-Circuit Television
CFCs	Chlorinated Fluorocarbons

Design & Construction Standards

CPSM	Construction & Professional Services Manual
CRSI	Concrete Reinforcing Steel Institute
CSA	Canadian Standards Association
DAPC	Division of Air Pollution Control
DC	Direct Current
DCC	Data Communications Channel
DDC	Direct Digital Control
DEB	Division of Engineering & Buildings
DHR	Virginia Department of Historic Resources
DOLI	Virginia Department of Labor & Industry
DVD	Digital Versatile Disc
DX	Direct Expansion
EPA	Environmental Protection Agency
FACP	Fire Alarm Control Panels
FRP	Fiber-Reinforced Plastic
FSC	Forest Stewardship Council
GBI	Green Building Initiative
GC	General Contractor
GFCI	Ground-Fault Circuit Interrupters
GPF	Gallons Per Flush
GPM	Gallons Per Minute
HART	Highway Addressable Remote Transducer
HCFCs	Hydrochlorofluorocarbons
HMMA	Hollow Metal Manufacturers Association
HUD	Housing & Urban Development
HVAC	Heating, Ventilation, & Air-Conditioning
HVLP	High Pressure Low Volume
IgCC	International Green Construction Code
ILSM	Interim Life Safety Measures
IPC	International Plumbing Code
JCAHO	Joint Commission on Accreditation of Healthcare Organizations
LBP	Lead-Based Paint
LCD	Liquid Crystal Display
LED	Light-Emitting Diode

Design & Construction Standards

LEED	Leadership in Energy & Environmental Design
MCC	Motor Control Center
MDP	Main Distribution Panel
DAPC	Division of Air Pollution Control
DC	Direct Current
DCC	Data Communications Channel
DDC	Direct Digital Control
DEB	Division of Engineering & Buildings
DHR	Virginia Department of Historic Resources
DOLI	Virginia Department of Labor & Industry
DVD	Digital Versatile Disc
DX	Direct Expansion
EPA	Environmental Protection Agency
FACP	Fire Alarm Control Panels
FRP	Fiber-Reinforced Plastic
FSC	Forest Stewardship Council
GBI	Green Building Initiative
GC	General Contractor
GFCI	Ground-Fault Circuit Interrupters
GPF	Gallons Per Flush
GPM	Gallons Per Minute
HART	Highway Addressable Remote Transducer
HCFCs	Hydrochlorofluorocarbons
HMMA	Hollow Metal Manufacturers Association
HUD	Housing & Urban Development
HVAC	Heating, Ventilation, & Air-Conditioning
HVLP	High Pressure Low Volume
IgCC	International Green Construction Code
ILSM	Interim Life Safety Measures
IPC	International Plumbing Code
JCAHO	Joint Commission on Accreditation of Healthcare Organizations
LBP	Lead-Based Paint
LCD	Liquid Crystal Display
LED	Light-Emitting Diode

Design & Construction Standards

LEED	Leadership in Energy & Environmental Design
MCC	Motor Control Center
MDP	Main Distribution Panel
NAE	Network Automation Engine
NEC	National Electric Code
NEMA	National Electrical Manufacturers Association
NESHAP	National Emission Standards for Hazardous Air Pollutants
NFPA	National Fire Protection Association
NIST	National Institute of Standards & Technology
O&M	Operation & Maintenance
ODP	Open Drip Proof
OEHS	Office of Environmental Health & Safety
OS&Y	Outside Screw & Yoke
OSB	Oriented Strand Board
PCBs	Polychlorinated Biphenyls
PVC	Polyvinyl Chloride
QEI	Qualified Elevator Inspector
RACM	Regulated Asbestos-Containing Material
RCRA	Resource Conservation & Recovery Act
RFCI	Resilient Floor Covering Institute
SCAQMD	South Coast Air Quality Management District
SDI	Steel Door Institute
SWaM	Small, Women-owned, & Minority-owned Business
TAB	Test and Balance
TBD	To Be Determined
TCLP	Total Concentrate Leachate Procedure
TCNA	Tile Council of North America
TEAO	Totally Enclosed Air Over
TEFC	Totally Enclosed Fan Cooled
TMS	The Masonry Society
UPC	Uniform Plumbing Code
UPS	Uninterruptible Power Supply
USBC	Virginia Uniform Statewide Building Code
USC	United States Code

Design & Construction Standards

USGBC	United States Green Building Council
VAT	Vinyl Asbestos Tile
VCC	Virginia Construction Code
VCT	Vinyl Composition Tile
VCU	Virginia Commonwealth University
VCUAIT	Virginia Commonwealth University Academic Information Technology
VCUHS	Virginia Commonwealth University Health System
VOC	Volatile Organic Compounds
VoIP	Voice over Internet Protocol
VOSH	Virginia Occupational Safety & Health
VSD	Variable Speed Drives

Design & Construction Standards

Division 01: General Requirements

01.01 Design Philosophy

The total cost of ownership should be considered as an important factor when specifying materials and equipment. It is incumbent upon the project design team to be cognizant of the long term costs and ease of maintenance for all systems and finishes.

01.02 General

No-Work (Blackout) Days (continued)

Noisy, disruptive, construction work will typically not be allowed during the following times:

- Exams
- Clinic Days
- Commencement
- Open House Dates

Refer to the annual calendar on the VCU website:

<http://events.vcu.edu>

The VCU Project Manager shall coordinate with the VCU Campus Coordinator for work in the streets and sidewalks, since the VCU Campus Coordinator is familiar with other utility work in the public way.

On occasion, Housing, Student Affairs, and other units will schedule outdoor events in open spaces on campus. The construction phase Project Manager shall verify that open space is unscheduled before turning it over to the Contractor.

Design Features That are Difficult to Service

Design features that require specialized equipment to maintain and/or are difficult to access shall be prohibited.

If noisy operations will disrupt student study time, the work must be rescheduled. If work will block streets, that work must be rescheduled to times other than student move-in or move-out. Disruptive work must be scheduled after normal class times. If the work is in an occupied building and will disrupt ongoing classes, research, or office operations, work must be rescheduled. Work adjacent to residence halls is particularly sensitive, and must accommodate normal sleep times for students. VCU Project Managers and or VCU Campus Coordinators, may be able to assist Contractors in obtaining "Work in the Streets" permits from the City of Richmond.

This provision is to avoid items such as light fixtures that require scaffolding to be erected to be able to service.

Design & Construction Standards

01.03 Emergencies, Safety, & Security

Emergency Contact Information

Prior to mobilization, the Contractor must provide the construction phase Project Manager a list of management personnel assigned to the project, including a 24-hour emergency point-of-contact.

Name	Phone number	Functional Responsibility
Chanel Derricott	(804) 828-7248 / 400-2192	MCV Campus Coordinator
Margaret Kelland	(804) 828-7269 / 400-2190	Monroe Park Campus Coordinator
VCU Police Emergency	(804) 828-1234	VCU Police
Fire / Medical Emergency	First 911, Then (804) 828-9364	Fire
Other Emergencies	(804) 828-9364	VCU Physical Plant Operations Center

Safety & Security

- Contractor’s personnel are required to wear ID badges provided by the firm doing the work.
- The University does not permit Contractor’s personnel to antagonize or shout at students, faculty, staff, or others.
- **VCU is a research and medical institution, and has many hazardous areas. Contractor’s personnel should observe and heed all warning signs.**
- Jobsite security is the Contractor’s responsibility (i.e. control access, shrinkage, etc.)

Worker Behavior & Decorum

Contractor’s personnel shall refrain from contact with students, faculty, and staff; other than for interaction necessary for the execution of their contract responsibilities. Expressly prohibited is contact in the form of harassment, whistles, cat-calls, comments, gestures, or any form of uninvited communication. Violation of this policy, even once, will

Design & Construction Standards

result in immediate and permanent removal of violators from the project site.

01.04 Special Work Restrictions by Building

Certain VCU facilities are so heavily used or are so environmentally sensitive, that special provisions apply.

Sanger Hall

- Sanger Hall houses animal facilities, which are sensitive to noise, vibrations, temperature, and humidity fluctuations within the animal environments.
- Sanger Hall houses teaching and research facilities, which are also sensitive to noise and construction disruptions.
- Sanger Hall's loading dock must be kept clear of all Contractor vehicles, unless prior permission is granted.
- Sanger Hall houses an electron microscope in Sanger room 3-0067. This room is sensitive to vibration and electromagnetic interference.

West Hospital

Because West Hospital houses VCU Health System (VCUHS) Clinics, this building is subject to accreditation requirements for the Joint Commission on Accreditation of Healthcare Organizations (JCAHO). As such, the conduct of work including clean-up and temporary provisions, must be carefully monitored.

- Complete the highlighted portions of the VCUHS Construction and Renovations Permit and Assessment Worksheets. Project Managers should contact Carlos Brown when doing projects in West Hospital, because there are very few patient contact areas in West Hospital and a permit is not necessarily required for every project.
- Bring the design documents, the approved CO-17 Building Permit for Bureau of Capital Outlay Management (BCOM) reviewed projects, and the semi-completed VCUHS Construction Permit, to the Permit Review meeting when

Note: Unless specifically permitted, all construction work in Sanger Hall must be performed during nights and weekends.

Note: All projects on levels 2 -10 within West Hospital, must have a completed and approved VCUHS Construction and Renovation Permit before work begins. Said Permit shall be presented to the VCU Health System Permit Review Committee for approval. This group meets every Wednesday at 2:00 PM in the Epidemiology Conference room on the second floor of North Hospital. The VCU Project Manager is responsible for completing and maintaining all paperwork, including the submission of daily Interim Life Safety Measures (ILSM) when applicable, the

Design & Construction Standards

held. If the project was not reviewed by BCOM, the Director of Capital Outlay for VCUHS or the Director of Construction Management for VCU, shall review the design for Code Compliance and sign on the VCUHS Code Official line of the VCUHS Construction Permit.

- Special Hospital Requirements Include:
 - *Infection Control Procedures:* (May impact the cost, and should be identified and establish prior to bid. This activity may occur prior to presenting the permit to the review board. Contact Epidemiology for assistance, Janis Ober 828-2121.) Strict adherence to these measures must be followed; all hospital staff are trained to enforce compliance with these standards, and will report any deviations to their supervisor.
 - *Daily Interim Life Safety Measures Checklists:* When these measures are required, a copy of the checklist must be completed by the Contractor and faxed to the Hospital's Safety Office by 9:00 AM the following morning. Use "TBD" if the dates of the ILSMs that are required are unknown at the time of permitting. Each Monday morning at 8:30 AM, an ILSM meeting is held in West Hospital room 624, in which the previous weeks ILSMs are checked and the current week's ILSMs are scheduled. Attendance is not mandatory, but the dates for your ILSMs must be presented. For assistance, contact the Director of Capital Programs with the information for presentation. These documents are critical for JHACO compliance.
 - *Health System's Contractor Training for the Foremen and Supervisors:* A Copy of the training manual / DVD is located at 700 West Grace Street. This training is valid for one year from issuance of card.

maintenance of the Containment Log, the submission of As-built drawings, and proper close-out of the project. The Director of Capital Programs for the Health System is available as a resource to assist the Project Manager with any questions.

Design & Construction Standards

- *Hot Works Permits*: Note requirements on permit.
- *Daily Construction Containment Inspection Log*: The log must be updated daily and maintained on-site.
- *Badges for Non-Temporary Contractors*: VCU badges are suitable.
- *Project Closeout Documentation*: See permit for requirements. Bring back to Permit Review Board for final signatures. All of the original ILSM sheets, and the complete Daily Containment Log must be included.
- A copy of the Construction Permit must be on-site at all times during construction.

Molecular Medicine Research Building

This building houses animals in the penthouse. Any potential for noise, vibration, temperature, or humidity fluctuations, should be reported to the construction phase Project Manager before work begins.

Student Housing

Since VCU is in an urban environment, security is extremely important.

Harris Hall

Harris Hall is very tightly scheduled. Classes often run continuously from 6 AM until 10 PM all weekdays. For this reason, it is difficult to schedule major shutdowns and difficult to schedule work.

Massey Cancer Center / Dalton Oncology

Massey Cancer Center houses small animals. Any potential for noise, vibration, temperature, or humidity fluctuations, should be reported to the construction phase Project Manager. Because Massey Cancer Center houses VCUHS Clinics, is it subject to JCAHO accreditation requirements. As such, the conduct of work including clean-up and temporary provisions, must be carefully monitored.

01.15 Traffic / Parking / Work in the Street or Sidewalk

Parking Policy

Design & Construction Standards

The Contractor is responsible for providing parking for their personnel. In an urban environment, parking is scarce and could be a significant issue that should be considered early in project planning, and in the cost estimate. No parking is allowed on paved driveways or roads. Vehicles shall not be parked on grass, planted areas, or sidewalks. Vehicles shall not block any means of access or egress. The planning phase Project Manager shall notify VCU Parking and Transportation when parking lots will be disrupted as early as possible. However, these lots should not be closed until a firm construction date is known, and the Contractor is ready to mobilize.

Vehicular & Pedestrian Traffic Management Plan

A/E's and Project Managers should consider the impact of the project on surrounding vehicular and pedestrian traffic flow, and take the necessary steps (such as signage, barricades, and re-striping) to ameliorate problems. These efforts should be included in the schedule, and in the cost estimate. Temporary signage may be needed.

01.05 Administrative Requirements

Roles & Responsibilities

The following describes the roles and responsibilities for project decision-making for planning, design, construction, and project turnover.

Schematic Design

The planning phase Project Manager shall deliver Schematic design documents in electronic format to the Director of Physical Plant (or designees as directed), at completion of the design phase.

This is when the commissioning agent will be brought on board. The Director of Physical Plant shall be responsible for submitting comments to the planning phase Project Manager.

Design Development & Working Drawings

During this phase, the planning phase Project Manager shall conduct a review session with the Design & Construction Standards Committee at the end of each phase, and shall identify appropriate resource personnel for inclusion in the Building Committee design

***Note:** Physical Plant with manage and tour this process.*

Design & Construction Standards

meetings. Project Managers must coordinate audio visual, data, telecommunications, and security during this phase, and inclusion in the cost estimate. Be specific to show the location and number of data drops. Check on janitorial closet space needs, ground storage space needs, and office maintenance and storage needs.

Construction

- **Minority (SWaM) Utilization**

It is the policy of the Commonwealth of Virginia to contribute to the establishment, preservation and strengthening of minority business enterprises, and to encourage the participation of minority businesses in State procurement activities. Towards that end, the Owner encourages firms to provide for the participation of minority owned businesses through partnerships, joint ventures, subcontracts, and other contractual opportunities.

- **Drug-Free Workplace Required**

Bidders are reminded that **Section 2.2-4312** of the Code of Virginia, requires that during the performance of the contract resulting from this solicitation, the Contractor agrees to (i) provide drug-free workplace for the Contractor's employees; (ii) post in conspicuous places, available to employees and applicants for employment, a statement notifying employees that the unlawful manufacture, sale, distribution, dispensation, possession, or use of a controlled substance, or marijuana is prohibited in the Contractor's workplace, and specify the actions that will be taken against employees for violations of such prohibition; advertisements for employees placed by or on behalf of the Contractor, that the Contractor maintains a drug-free workplace; and (iii) include the provisions of the foregoing clauses in every subcontract, or purchase order over \$10,000, so that the provisions will be binding upon each

Design & Construction Standards

subcontractor or vendor.

- “Drug-Free Workplace” means a site for the performance of work done in connection with a specific contract awarded to a Contractor, in accordance with this solicitation, the employees of whom are prohibited from engaging in the unlawful manufacture, sale, distribution, dispensation, possession, or use of any controlled substance, or marijuana during the performance of the contract.

01.06 Construction Site

Construction Sign

A construction sign will be posted at a location to be determined by the VCU Project Manager. The cost of mounting and disposing of the sign, shall be included in the Contractor’s general condition’s cost.

Design and graphics for signs must be approved by the VCU Project Manager.

Staging & Lay-Down Areas

Staging and lay-down areas are very limited. The impact of this should be considered in the schedule and cost estimate, especially if off-site lay-down or staging areas are required.

Contractor Signage

The Contractor may mount or display company logo signage, after the proposed type, size, verbiage, and location is approved by VCU.

Temporary Construction Barriers

If construction barriers are needed, the type of barrier will be determined by both project scope, and length of use of the material. Caution tape may be used for a period not to exceed one day. Plastic safety fence may be used for a period not to exceed one week. Portable chain link fence panels are to be used for longer durations. Plywood barriers may be needed for closed sidewalks adjacent to construction sites.

Interior Temporary Partitions & Barriers

Interior temporary partitions are to be specified as part of the design documents. The Contractor shall provide spare keys to temporary locks for the construction phase Project Manager, in

Temporary partition materials must comply with building code requirements for construction type and use of the existing facility.

Design & Construction Standards

case emergency access is required.

01.07 Permits & Shut-Downs

Hot Work Permit

Any activity in an existing or occupied facility that generates heat, e.g. welding, soldering, torch-cutting, etc., is require a Hot Work Permit. These permits are available through VCU Fire Safety, by contacting (804) 828-0040.

Building Permits

Because this is a Project of the Commonwealth of Virginia, codes or zoning ordinances of local political subdivisions do not apply.

However, the Virginia Uniform Statewide Building Code (VUSBC) shall apply to the Work, and will be administered by the Building Official for State owned buildings. The CO-17 Building Permit will be obtained and paid for by the Owner. All other permits, local license fees, business fees, taxes, or similar assessments imposed by the appropriate political subdivision, shall be obtained and paid by the Contractor.

Fire Protection System Shut-Downs

Shut down of fire suppression, fire alarm, and other fire protection systems, shall be coordinated with VCU Fire Safety through VCU Construction Management. A 14 day minimum notice is required, along with provision of a fire watch provided by the Contractor requesting the outage.

Exits

No work shall take place which obstructs the buildings means of egress, without first coordinating with VCU Fire Safety.

***Note:** Additional temporary partitions and doors may be required to eliminate dead-end conditions, and redirect exit access away from a blocked exit.*

Electrical Shutdowns

Shut-down of electrical systems must be coordinated with end users, and Facilities Management through VCU Construction Management. A 14 day minimum notice is required. Critical systems may require a provision of alternate or temporary power. The A/E shall identify critical systems during design, and determine

Design & Construction Standards

requirements to be included in the construction documents.

01.08 Project Completion

As-Built Documents

The Contractor shall complete and deliver As-Built documents within 6 months of project completion. VCU will retain a portion of the fee to ensure timely delivery of the documents. Failure to deliver As-Built documents on a timely basis, will be considered as criteria in future A/E and Contractor selections.

Close-Out Documents

Operation and Maintenance (O&M) manuals are to be provided during O&M training for VCU Facility Management personnel. Specific warranty information is to be provided prior to, or at Substantial Completion.

Attic Stock

Attic Stock is to be specified for each finish used per project. Specifiers should consult with the VCU Project Manager to determine the quantity of materials, and storage location.

01.09 Sustainable Design Requirements

LEED (Leadership in Energy & Environmental Design) Certification

All VCU new construction and renovations greater than 5000 square feet, will be designed to LEED Silver standards which include enhanced commissioning.

See "Division 18 Sustainability" section for additional guidance.

01.10 Commissioning

In general, construction and renovation projects with a construction budget of \$1 million dollars or greater will be commissioned. Projects with a value less than \$1 million dollars, will be commissioned if they affect vivarium, scientific, or clinical laboratory spaces. Projects affecting patient care spaces, with a value less than the threshold, will be considered for commissioning. Additionally, projects of less than the designated threshold value, that because of technical considerations or significant adverse

Design & Construction Standards

effects on the University community, will be considered for commissioning.

Commissioning will normally be procured by utilization of the statewide open end contract for commissioning services, administered by the Department of General Services, Division of Engineering and Buildings (DEB).

For projects seeking some level of LEED certification, the minimum basic commissioning required as a prerequisite will be done.

Enhanced commissioning is encouraged, and will be considered for the additional LEED point that it generates.

Details as to specific systems to be commissioned and the degree and depth of the required commissioning, will be provided in the Request for Quote for Services under the State Contract. Normally, the Commissioning Agent will develop and write the commissioning specification and plan for the project manual, subject to review by VCU.

Unless otherwise provided by the State Contract, the Project Manual, the Request for Quote for Service under the State Contract by VCU, the LEED requirements, or other specific direction by VCU, commissioning will be done in compliance with the most recent versions of the

American Society of Heating, Refrigerating, and Air-Conditioning Engineers (ASHRAE):

- [ASHRAE Guideline 0](#): The Commissioning Process
- [ASHRAE Guideline 1](#): The HVAC Commissioning Process
- [ASHRAE Guideline 4](#): Preparation of Operating and Maintenance Documentation for Building Systems.

Generally, Physical Plant will procure the commissioning agent, who will prepare the scope of work in consultation with the planning phase Project Manager and Construction Program Manager.

Design & Construction Standards

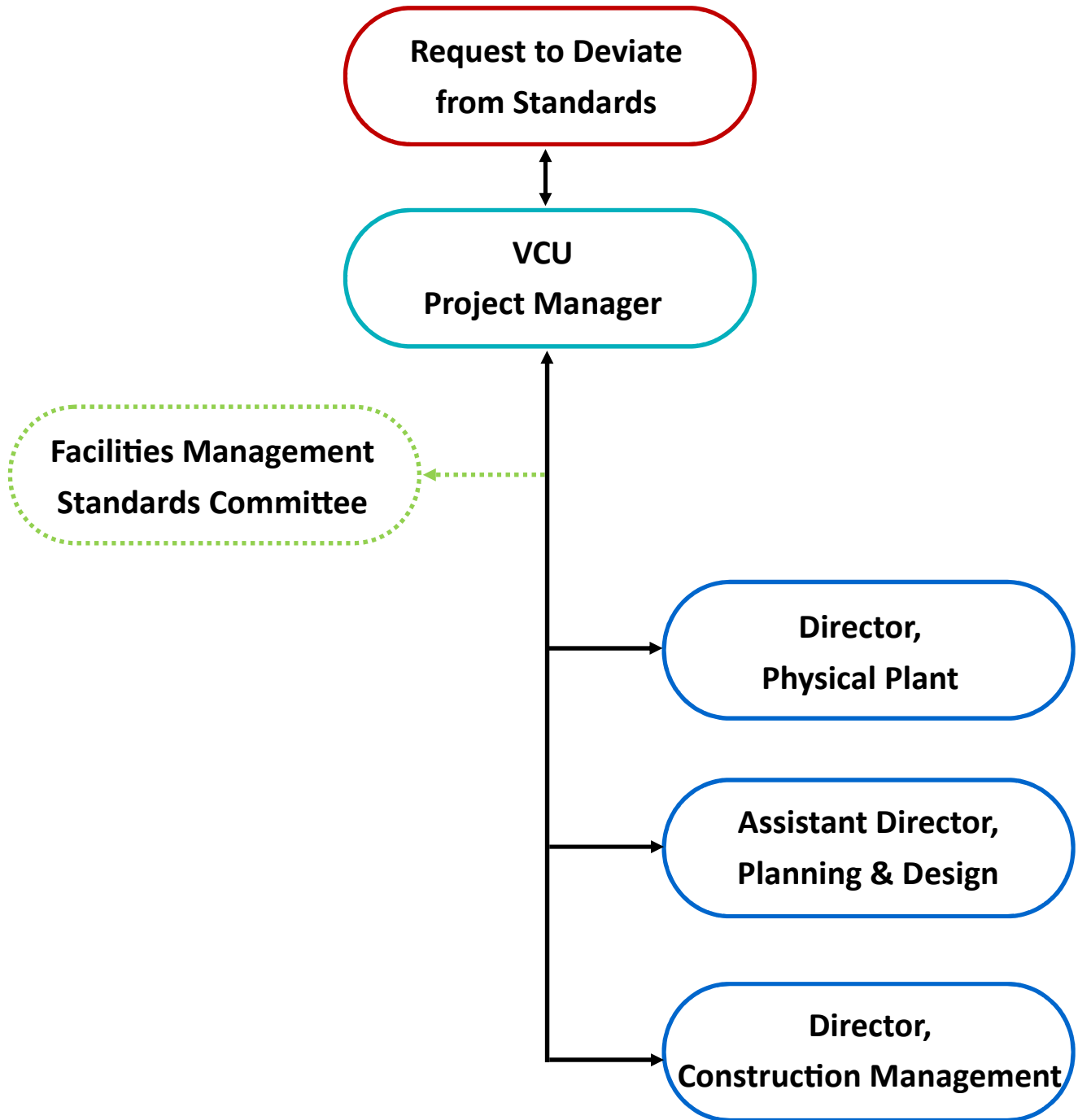

End of Division 1

Design & Construction Standards

Division 02: Existing Conditions

02.10 General

Vermin Protection

All demolition and construction sites shall be pre-treated by a pest control contractor, to place bait stations and mechanical devices near the demolition site or the perimeter of nearby occupied buildings, to curtail rodent activity from moving to nearby occupied buildings.

Infection Control

Due to the presence of Aspergilla spores present in soils, all ground disturbances on the VCUHS campus must comply with the hospital's Infection Control Policy, established for each project as directed by the Hospital Epidemiologist.

The hospital's Epidemiologists should provide specific recommendations and protocols based on the risks presented by each project.

02.20 Asbestos / Lead Abatement

Refer to the most current edition of the Virginia Construction and Professional Services Manual (CPSM) together with any subsequent DEB notices or revisions, as currently posted on the Virginia Department of General Services' website.

<http://www.dgs.virginia.gov/DivisionofEngineeringandBuildings/BCOM/CPSM/2016CPSM-Rev0/tabid/1570/Default.aspx>

See 4.12 of the 2016 CPSM for required special procedures for asbestos abatement. See 4.13 of the 2016 CPSM for required lead-containing building materials procedures.

The following VCU facilities have special asbestos alerts:

West Hospital	It has asbestos throughout almost all aspects of the building's components.
Lyons	There is asbestos above the fourth floor ceilings, and in select areas on other floors.
Harris Hall	Although it has been incrementally abated over the years, there are ceiling tiles in a few remaining rooms that contain asbestos, along with the auditorium.
Franklin St. Gym	The mastic on the vapor barrier underneath the brick facade is a typical condition, and has been found to contain approximately 10% Chrysotile asbestos (MPC 7-08).

Design & Construction Standards

If asbestos is found in floor tile or floor tile mastic, VCU policy states that the floor must be abated and removed, rather than covering over it with carpet or some other floor materials.

Specifically require abatement contractor(s) to comply with the 20 working-day notice requirement to the Virginia Department of Labor and Industry in advance of beginning any asbestos abatement.

02.21 General Project Requirements — Asbestos

Buildings constructed prior to 1980 are presumed to have Asbestos-Containing Materials (ACMs) in many typical materials, until such materials have been tested and found not to contain asbestos. Existing facilities constructed prior to January 1, 1985 must be inspected by a Virginia-licensed or properly certified asbestos inspector who must provide their signed (certified) report.

An estimated cost for asbestos abatement when suspected or predetermined, shall be included in the cost estimate supporting the construction budget or budget request. For renovation, demolition, or addition projects, including roofing materials, the University shall test for ACMs prior to submittal of the preliminary design. The asbestos survey and inspection report must be made available to the project A/E for information and use in preparing the project documents.

If ACMs are found, the University shall have a licensed asbestos designer in consultation with the A/E, shall prepare an asbestos abatement plan and prepare or update the University Asbestos Management Plan as required by the University, in compliance with §2.1-1164, Code of Virginia. The asbestos abatement contractor shall be required to mark up the Asbestos Management Plan to show the “As-Built” conditions resulting from its work; to include areas where asbestos was abated, areas where asbestos was encapsulated, and areas where ACMs exist, but were left in place.

Based on the report of the asbestos survey and inspection report and

See CPSM 4.12.11. Note the use of “working days.” Contractor must add additional time for weekends and holidays as appropriate.

Possible ACMs includes but is not limited to, asphalt and vinyl flooring, resilient floor covering, mastics, fibrous pipe insulations and lagging materials, caulking, roofing, flashings, cement boards and composite sidings, bonding agents, coatings, and various binders and adhesives.

ACMs abatement designers and A/E’s can coordinate with each other, but neither can legally be responsible for the other’s work, since the licensing and insurance requirements for each discipline are very different.

The report and “As-built”

Design & Construction Standards

the Asbestos Management Plan, the construction drawings for renovation or addition projects shall indicate all locations where ACMs were found, where ACMs are to be disturbed, and where ACMs are to remain. The asbestos survey and inspection report and the Asbestos Management Plan, must be made available for their respective information to the contractor(s) for demolition and for construction.

Include the appropriate Asbestos Disclosure Statement on the demolition plan sheets, and the floor plan sheets for all disciplines and for each floor. See the current edition of the CPSM for approved language.

The VCU Project Manager will verify that the A/E and the licensed asbestos designer have coordinated their design work with each other, and the licensed abatement contractor has coordinated and verified their work and project scope with other contractors.

02.22 Asbestos Removal

All ACMs that will be disturbed as a result of a renovation, demolition, or addition project, must be removed.

The University will have asbestos project specifications written by a Virginia licensed designer. The designer's license number, name, and signature must appear at the beginning of the asbestos specifications.

The asbestos project specifications shall adhere to all current Federal and State regulations and policies.

The specifications shall include a copy of the project specific asbestos inspection report and Asbestos Management Plan, indicating the sampling of and analyses for all materials that will or may be disturbed or accessed by the project. The specifications shall include a section that covers project notification by the asbestos contractor to the United States Environmental Protection Agency (EPA), the Virginia Occupational Safety and Health (VOSH), and the Division of

documentation may be included as an appendix to the project manual (A/E specifications) when provided, otherwise they can be made available as standalone documents for bidder's reference. Be clear that these are provided for bidder's reference only and are not contract documents.

Each design and construction entity is obligated to coordinate their work with others, and to bring conflicts and discrepancies to the Owner's attention for resolution.

Use of a Virginia licensed asbestos abatement designer is mandatory. The asbestos abatement designer must be under direct contract with the University.

Design & Construction Standards

Air Pollution Control (DAPC), at least 20 calendar days prior to the actual start of the asbestos project.

The University has two contracting options for use, in the removal of asbestos from a structure and option two is the preferred method:

1. A separate contract for removal of the asbestos prior to renovation, demolition, or addition.
2. A contract where the abatement is an integral part of the renovation, demolition, or addition project, in which VCU Physical Plant is licensed as an asbestos contractor, or hires a licensed asbestos abatement subcontractor to perform the work.

The asbestos abatement contractor shall be required to mark-up the Asbestos Management Plan to show the “As-Built” conditions resulting from its’ work, to include areas where asbestos was abated, areas where asbestos was encapsulated, and areas where ACMs exist, but were left in place.

02.23 Use of Asbestos or Asbestos Containing Materials

The use of materials that contain asbestos is prohibited in any new construction or renovation.

02.24 Removal & Replacement of Sprayed-On Fireproofing

In consultation with the University, the A/E shall verify early in the design phase with the appropriate Fire Marshal, the original purpose of the fireproofing material to be removed or replaced and what, if anything, must be done to restore the fire resistive characteristics. Plans and specifications shall be submitted to the Fire Marshal, which will include any bidding documents, addenda, or change orders from the original construction, which may relate to the fire resistive characteristics of the structure. On a submittal to the Fire Marshal, indicate the original construction date, and any renovation or alteration dates, original and present uses, height of floors in feet, and whether sprinkler or any other information that may assist the Fire Marshal in his determination, be provided.

This is in the HECO Manual

Design & Construction Standards

If sprayed-on ACMs are to be replaced, the University or its' A/E shall also submit copies of the specifications for the intended replacement material, and the bridging encapsulate specified by the asbestos project designer for review by the Fire Marshal.

Require that the spray-applied fireproofing applicator provides bridging encapsulate that is correctly matched with the replacement fireproofing material, to ensure maximum bonding strength and intended fire rating integrity of the assembly, and acceptable flame spread ratings.

02.25 Asbestos Related Work Insurance Requirements

Asbestos inspectors, project designers, project monitors, and their firms, are required to provide evidence of professional liability or errors and omissions insurance, with asbestos coverage in an amount not less than \$1,000,000.00. VCU, its' officers, employees, agents, or any other persons acting in an official capacity, temporarily or permanently in the service of the Commonwealth, should also be named as additional insured persons.

Delete this as it is in the HECO Manual

Asbestos contractor or subcontractor, as the case may be, to name the A/E as an additional insured on the Contractor's liability insurance with asbestos coverage. Where the A/E for the renovation project is also a Virginia licensed asbestos designer, and prepares the asbestos project drawings and specifications, the requirement to name the A/E as an insured party is waived.

02.26 Special Procedures for Lead-Containing Materials

See the *General Conditions of the Construction Contract* for references to lead regulations, and the Virginia DOLI permitting requirements.

DGS-30-054 (09/12), subparagraph 3(h), including subordinate clauses (1) through (3).

When planning a renovation, demolition, or addition project, the VCU OEHS shall have the facility to be renovated, surveyed for lead-containing building materials by a Virginia licensed lead inspector or risk assessor, and document in a lead inspection report all quantities and locations found. If the structure is to be demolished, the lead inspector or risk assessor shall determine whether a Total Concentrate Leachate Procedure (TCLP) test is warranted.

See also CPSM 4.13.3

Design & Construction Standards

U.S. Housing and Urban Development (HUD) Lead Testing

See also CPSM 4.13.3.1

All facilities which may house children 6 years of age and younger that were constructed prior to 1978, must have a lead materials and lead paint inspection and risk assessment conducted by a Virginia-licensed lead inspector and or risk assessor prior to being occupied by children 6 years and younger. Where abatement or renovation is to be conducted in these facilities, a Virginia-licensed lead project designer shall develop lead project specifications that comply with all EPA and VOSH regulations. A Virginia-licensed risk assessor or lead project designer shall insure that the requirements of the project specifications are followed, including the collection and documentation of all clearance samples.

An estimated cost for lead abatement, when suspected or predetermined, shall be included in the cost estimate supporting the construction budget or budget request. In addition to abatement, disposal budget estimates and requests shall include cost of Contractor compliance with Virginia DOLI requirements for the protection of construction workers for the specific project.

See also CPSM 4.13.2

In areas to be renovated, the agency shall include a copy of the lead inspection report as an appendix to the project specifications. Where lead materials are found in structures to be demolished, the agency shall determine if the structure has the potential to be considered a hazardous waste when demolished, and shall have a TCLP test conducted, if recommended by the lead inspector or risk assessor.

CPSM 4.13.4

Lead Materials Disclosure

CPSM 4.13.5

The title page of the construction drawings for renovation or addition projects, shall include the lead materials disclosure statement that follows:

An inspection to identify lead-containing or coated building components has been conducted, and can be found in the project specifications. This report is provided for the Contractor's use and may not be all inclusive. It is the Contractor's responsibility to comply with all VOSH regulations as they pertain to employee exposures to lead. All lead and lead-coated building components

Design & Construction Standards

shall be recycled to the extent possible.

Lead Notification

CPSM 4.13.6

In facilities where children 6 years and under may be located, and if lead-containing materials will be encountered by the General Contractor (GC), the A/E shall identify the type and location of all lead-based paint and notify the GC that this work is part of the contract for construction. Lead-based paint must be identified and the contractors notified that they must be in compliance with all EPA requirements for lead control and abatement in target housing, and all VOSH requirements for worker safety. It shall be the Contractor's responsibility to comply with all EPA and VOSH requirements.

Scheduling

VCU Project Manager must obtain information from facility occupants necessary for Contractor to coordinate effective schedule.

Require the Contractor to establish a schedule with the University for abatement and containment in buildings that are to remain occupied during construction.

Disposal Testing

CPSM 4.13.7

Following the demolition of lead-containing or coated building components which are designated as waste products, additional TCLP tests, in accordance with EPA guidelines, shall be done on these materials, which include the total waste stream, to determine disposal requirements. TCLP tests of waste materials shall identify whether the material will be required to be disposed of as hazardous waste, or as ordinary construction debris. It shall be unlawful for materials identified as hazardous waste to be disposed of with ordinary construction debris.

02.27 Resilient Floor Covering

Summary

If the floor tile, when dry, can be crumpled in one's hand, it is considered "friable". All friable materials must be removed using the standards from the National Emission Standards for Hazardous Air Pollutants (NESHAP). If the floor tiles are friable and total less than 10SF of surface area, the Armstrong method may be used. If the floor tiles total more than 10SF of surface area, NESHAP abatement methods are required.

There is a wide variety of resilient floor covering applications that contain asbestos. The most common are linoleum flooring and Vinyl Asbestos Tile (VAT). VAT is most commonly found in either a 9" x 9" or a 12" x 12" square size. The 9" x 9" VAT's are normally found in older buildings, because they were

Design & Construction Standards

In order to determine if a resilient floor covering is in poor condition, look for sections or tiles which are cracked or peeling to the extent that they are crumbled. If the floor covering is in poor condition, collect a small representative sample and seal it in a transparent, sample bag. Hand pressure should be applied to determine if the material can be crumbled, pulverized, or reduced to powder. If it can be crumbled, the Resilient floor covering that will be or has been sanded, ground, or material is considered friable.

Resilient floor covering that will be or has been sanded, ground or abraded is subject to NESHAP standards.

If the floor tiles are friable, they are considered Regulated Asbestos-Containing Material (RACM), and must be handled in accordance with NESHAP standards.

See <http://www.osha.gov/dcsp/osp/stateprogs/virginia.html> and

http://www.doli.virginia.gov/leadasbestos/leadasbestos_intro.html for current summary information regarding the Virginia State Plan.

Reference the Virginia Department of Labor & Industry (DOLI) fact sheets, “Renovation & Demolition of a Building / Facility” and the “VA Department of Labor & Industry Asbestos FACT Sheet” at the end of “Division 2: Existing Conditions”.

If floor tiles are non-friable and specify compliance with the Resilient Floor Covering Institute’s (RFCI) “Recommended Work Practices for Removal of Resilient Floor Coverings” including removal of residual adhesives, underlayment materials (if required), and the packaging and labeling of waste materials.

manufactured earlier than the 12" x 12" VAT's; however, floor tile sizes and resilient floor covering applications vary greatly since many buildings have been re-tiled several times.

Floor coverings in poor condition can often be found near doorways or loading / staging areas where the floor has sustained a lot of stress and traffic.

Regulated Asbestos-Containing Material (RACM) is (a) friable asbestos material, (b) Category I non-friable ACMs that has become friable, (c) Category I non-friable ACMs that will be or has been subjected to sanding, grinding, cutting or abrading, or (d) Category II non-friable ACMs that has a high probability of becoming, or has become crumbled, pulverized, or reduced to powder by the forces expected to act on the material in the course of demolition or renovation operations.

The October 2011 edition of RSCI's recommendations replace all prior editions and Armstrong Recommended Work Practices publications.

Design & Construction Standards

02.28 Disposal of Hazardous Materials

General

These guidelines are written to comply with LEED goals, and also to limit VCU's liability with respect to the disposal of hazardous waste. The diversion of construction and or demolition waste materials shall generally be accomplished through salvage, reuse, and recycling, as defined in the project specifications, with goals in accordance with LEED standards.

During Planning

1. The planning phase Project Manager shall contact OEHS to review and comment on hazardous material's inspection reports, specifications, work plans, etc., for technical accuracy, and for conformance with the base specifications provided by OEHS.
 - *Soils:* Hazardous material soil sample result submittals will be reviewed by OEHS for accuracy and consistency with VCU's policies and standards
 - *Building Waste:* Disposal of all hazardous waste Polychlorinated Biphenyls (PCBs), Lead-Based Paint (LBP), chemical waste, PCBs-containing ballasts, or any other Resource Conservation and Recovery Act (RCRA) regulated materials, universal waste (mercury-containing light tubes, mercury-containing thermostats, etc.) or any special wastes such as asbestos resulting from demolition, renovation, and or construction, must be coordinated through OEHS / Chemical Biological Safety Section (CBSS). The Project Manager should be aware of potentially contaminated research equipment, such as Biological Safety Cabinets (BSCs), chemical fume hoods, and other such equipment that may pose a health or environmental risk.
2. The planning phase Project Manager shall ensure that the cost for disposal of hazardous materials (all costs relating to

Important! *If hazardous waste is disposed of improperly during construction, VCU could be fined or sanctioned, or both. It is important to coordinate disposal of hazardous waste with OEHS.*

The key contact person at OEHS is Larry Mendoza (804) 828-2596.

Design & Construction Standards

the removal, disassembly, characterization, packaging, transportation, and disposal of such materials) is included in the project budget, and that the project specifications contain base specifications provided by OEHS.

During Construction

1. Unless otherwise noted, demolished materials shall become the Contractor's property, and shall be removed from the job site with further disposition legally.
2. All shipping and disposal documents of hazardous waste must be signed by a representative from OEHS / CBSS. Unless given explicit written permission by OEHS / CBSS, a Contractor may not sign disposal documents or manifests on behalf of VCU. With prior approval of OEHS, a Contractor may, if properly trained and or licensed, remove, disassemble, and or abate, and properly containerize such materials for disposal.
3. Construction phase Project Manager shall contact OEHS to review Contractor training / certification of project personnel permits, applications, and disposal documents.
4. Contractors must contact OEHS / CBSS when assessing potentially contaminated research equipment, such as BSCs, chemical fume hoods, and other such equipment that may pose a health or environmental risk.



Design & Construction Standards

RENOVATION and DEMOLITION OF A BUILDING/FACILITY

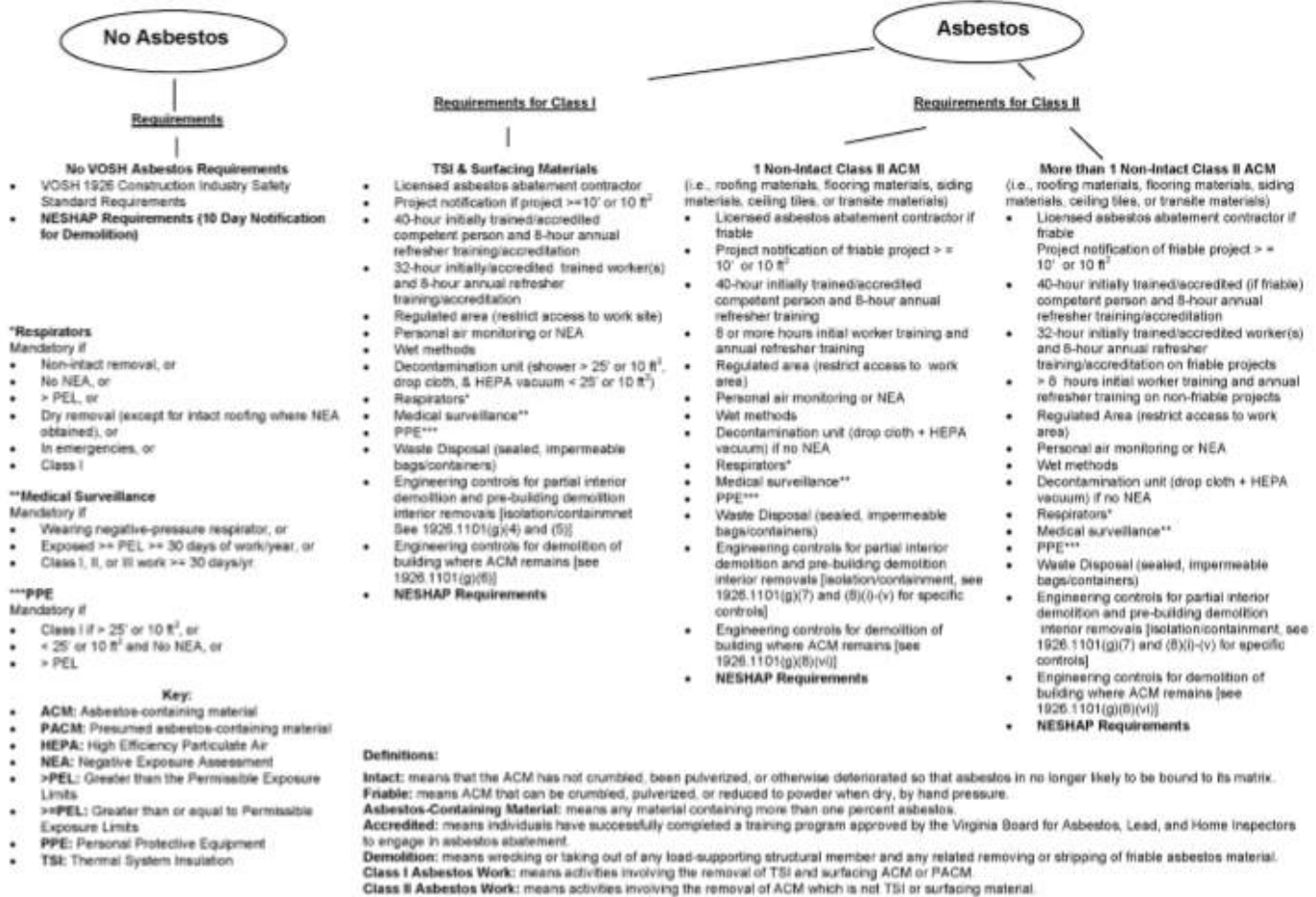



Design & Construction Standards

Virginia Department of Labor & Industry Asbestos FACT Sheet



Asbestos Containing Materials

Asbestos is the name given to a group of naturally occurring minerals used in certain products to resist heat and corrosion. Common products that contain asbestos include, but are not limited to, pipe and boiler insulation, spray-on insulation, floor tiles, ceiling tiles, patching and joint compound, roofing material and transite shingles and siding.

The primary characteristic that makes asbestos a concern is its ability to separate into microscopic needle-like fibers. Once these fibers become airborne, (usually by disturbing the product in which they are contained), they can be inhaled into the lungs. The inhalation of asbestos fibers can cause serious diseases of the lungs and other organs that may not appear until years after the exposure has occurred.

Background

The Virginia Department of Labor and Industry (DOLI) has comprehensive regulations to control the hazards of asbestos. DOLI regulates asbestos through enforcement of the Virginia Occupational Safety and Health (VOSH) regulations, enforcement of the U.S. Environmental Protection Agency's (EPA) Asbestos National Emission Standard for Hazardous Air Pollutants (Asbestos NESHAP), and enforcement of the Asbestos Notification regulations found in the Labor Laws of Virginia.

VOSH Asbestos Regulations

The State Plan agreement between the Federal Occupational Safety and Health Administration (OSHA) of the U.S. Department of Labor and Virginia gives DOLI authority to regulate occupational safety and

health for construction related activities. The VOSH Asbestos Construction standard, Part 1926.1101, regulates exposure to asbestos during demolition activities when asbestos containing material (ACM) is present, removing or encapsulating ACM, and renovation operations where ACM is present or could be potentially disturbed.

Asbestos NESHAP

The EPA established the Asbestos NESHAP as part of the Clean Air Act to protect the general public by minimizing the release of asbestos fibers when buildings or facilities which contain ACM are demolished or renovated. DOLI has been authorized by the EPA to provide direct enforcement in Virginia of certain parts of the Asbestos NESHAP including demolition and renovation activities.

Asbestos Contractor Notification Requirements

DOLI's Asbestos Notification and Permit Program regulations require written notification by licensed asbestos contractors for any asbestos abatement project that is at least ten linear or ten square feet. A notification is not required for nonfriable asbestos containing roofing, flooring, or siding materials which when installed, encapsulated, or removed do not become friable. Notifications must be submitted 20 calendar days prior to starting the asbestos project. Notifications should be sent to the address below by certified mail or hand delivery. Notifications may also be sent by facsimile (FAX) transmission for projects that do not require a fee or projects with fees paid by credit card.

A notification form can be obtained online from DOLI at: http://www.doli.virginia.gov/leadasbestos/leadasbestos_forms.html or by contacting the Department in writing at the address below:

Asbestos Program
Department of Labor and Industry
Powers-Taylor Building
13 South Thirteenth Street
Richmond, VA, 23219
Phone (804) 786-9865
Fax (804) 371-7634

The EPA must also be notified for any asbestos projects that are least 160 square or 250 linear feet and essentially for all demolition projects, regardless of whether asbestos containing materials are present in the structure or facility. Notifications required by the EPA must be sent to the Department as described above except the notification period is 10 working days.

*Note: The EPA does not allow FAX transmission. NESHAP required notifications must be mailed to the EPA at the address below:

Asbestos Coordinator
USEPA
Region III
Mail Code 3LC62
1650 Arch St.
Philadelphia, PA 19103-2029

Building Inspection Requirements

Building owners often are the only or best sources of information concerning asbestos hazards within their building. They along with employees of potentially exposed employees are assigned specific duties under the DOLI asbestos regulations. To comply with these regulations, a thorough inspection must be conducted prior to the start of

any demolition or renovation activity which may disturb ACM.

The EPA and DOLI have specific requirements for public and commercial buildings where renovation or demolition are to take place. Prior to the renovation or demolition, there must be an inspection for suspect ACM **regardless of the age of the building.**

The VOSH 1926.1101 Asbestos construction standard also requires that building owners and employers determine the presence of asbestos prior to any work that may disturb ACM. Thermal system insulation (TSI) and sprayed or troweled on surfacing material must be presumed to contain asbestos until testing indicates otherwise. Asphalt and vinyl flooring material installed no later than 1980 must also be considered as asbestos containing until testing determines that it is not.

If an appropriate building inspection has not been conducted for asbestos, an accredited asbestos inspector who has been licensed by the Virginia Department of Professional and Occupational Regulation (DPOR) should be obtained to conduct an inspection.

Demolition Projects

All demolition projects, with the exception of some residential structures, require notification 10 working days in advance **even if no asbestos is present.**



Design & Construction Standards

**Recommended Work Practices for
Removal of Resilient Floor Coverings**
Supersedes Recommended Work Practices Published in August 2004

OCTOBER 2011

R|F|C|i
Resilient Floor Covering Institute

115 Broad Street, Suite 201, LaGrange, GA 30240 | phone: 706.882.3833
fax: 706.882.3880 | www.rfci.com



Design & Construction Standards



Recommended Work Practices for Removal of Resilient Floor Coverings

WARNING

Do not sand, dry sweep, dry scrape, drill, saw, beadblast, or mechanically chip or pulverize existing resilient flooring, backing, lining felt, asphaltic "cutback" adhesive, or other adhesive.

These products may contain asbestos fibers and/or crystalline silica.

Avoid creating dust. Inhalation of such dust is a cancer and respiratory tract hazard. Smoking by individuals exposed to asbestos fibers greatly increases the risk of serious bodily harm.

Unless positively certain that the product is a non-asbestos-containing material, you must presume it contains asbestos. Regulations may require that the material be tested to determine asbestos content.

RFCI's Recommended Work Practices for Removal of Resilient Floor Coverings are a defined set of instructions addressed to the task of removing all resilient floor covering structures.

MAY 2011

1



Design & Construction Standards

IN CANADA

The Recommended Work Practices for the Removal of Resilient Floor Covering Materials are intended for use in the United States. The work practices for the removal of in-place resilient floor coverings and associated adhesives described in this publication have not been reviewed with either National or Provincial officials in Canada to determine their applicability when asbestos-containing or assumed to be asbestos-containing resilient floor covering materials are encountered. These work practices are recommended when removing resilient floor covering and its associated adhesives that have been determined not to be asbestos-containing.

To determine what are acceptable work practices and the associated requirements for the removal of resilient floor covering that is assumed to contain asbestos or has been determined to contain asbestos, you should contact your local or provincial officials.

As an alternative to the removal of any in-place resilient floor covering materials, refer to page 9 (Alternative to Removal of Existing Resilient Floor Coverings).



Design & Construction Standards

TABLE OF CONTENTS

- IMPORTANT INFORMATION CONCERNING EXISTING FLOOR COVERING INSTALLATIONS...4
- IMPORTANT INFORMATION: MOLD AND MILDEW.....5
- OSHA REQUIREMENTS.....6
- EPA LEAD-BASED PAINT REQUIREMENTS.....7
- GENERAL RULES FOR REMOVAL OF RESILIENT FLOOR COVERING.....8
- ALTERNATIVES TO REMOVAL OF EXISTING RESILIENT FLOOR COVERINGS
 - Installing resilient floor covering over existing resilient floor covering.....9
 - Use of embossing leveler.....9
 - Installing resilient floor covering over new underlayment.....9
- REMOVAL OF RESILIENT SHEET FLOORING
 - Supplies and tools.....10
 - Fully-adhered resilient sheet flooring.....11
 - Unadhered (loose-lay) or peripherally-adhered resilient sheet flooring.....14
- REMOVAL OF RESILIENT TILE
 - Supplies and tools.....16
 - Removal procedure.....17
- REMOVAL OF RESIDUAL ADHESIVE
 - Supplies and tools.....21
 - Wet-scraping residual adhesive.....25
 - Complete removal of Asphaltic "cutback" Adhesive.....26
- COMPLETE REMOVAL OF WOOD UNDERLAYMENT
 - Supplies and tools.....28
 - Wood underlayment with sheet flooring.....29
 - Wood underlayment with tile flooring.....31
 - Removal of wood underlayment boards.....33



Design & Construction Standards

NOTICE

Various Federal, State and local government agencies have regulations governing the removal of in-place asbestos-containing material. If you contemplate the removal of a resilient floor covering structure that contains (or is presumed to contain) asbestos, you must review and comply with all applicable regulations.

This booklet replaces all prior editions of the RFCI and Armstrong Recommended Work Practices Publications. Please note that these recommended work practices are subject to change as new practices are incorporated. It is your responsibility to determine that the recommended work practices you use are those in effect.

Important Information for Installers of Resilient Floor Coverings Concerning Existing Resilient Floor Covering Structures

- Vinyl asbestos tile and asphalt tile contain asbestos fibers, as did some asphaltic "cutback" adhesives and the backings of many sheet vinyl floorings and lining felts. The presence of the asbestos in these products is not readily identifiable.
- While resilient floor covering products manufactured today do not contain asbestos, the asbestos used in the older products was encapsulated in the matrix of the product. The Environmental Protection Agency (EPA) recognizes that those products are non-friable (i.e. when dry cannot be crumbled, pulverized or reduced to powder by hand pressure) unless certain activities prohibited by the removal practices in this booklet occur.
- Unless positively certain that the product you intend to remove is a non-asbestos-containing material, you must presume it contains asbestos. Regulations may require that the material be tested to determine asbestos content.
- RFCI's Recommended Work Practices are a defined set of instructions addressed to the task of removing all resilient floor covering structures whether or not they contain asbestos. When RFCI's Recommended Work Practices are followed, resilient floor covering structures that contain (or are presumed to contain) asbestos can be removed in a manner that will comply with the current Occupational Exposure to Asbestos Standard's Permissible Exposure Limits (PEL) issued by the Occupational Safety and Health Administration (OSHA).
- Numerous products, devices and techniques have been recently introduced and/or recommended for the removal of resilient floor covering structures. Before you use any practices other than those identified in this booklet for the removal of an in-place resilient floor-covering product that contains (or is presumed to contain) asbestos, you must determine that the practice meets all applicable regulations or standards including the OSHA standards for occupational exposure to asbestos and the EPA asbestos regulations. You must also determine that any materials used during the removal practice will be compatible with the new floor covering to be installed.



Design & Construction Standards

Mold and Mildew

Prior to removing an existing resilient floor following the **RFCI Recommended Work Practices for Removal of Resilient Floor Coverings** (unless state or local law requires other measures) or installing a new floor, if there are visible indications of mold or mildew or the presence of a strong musty odor in the area where resilient flooring is to be removed or installed, the source of the problem should be identified and corrected before proceeding with the flooring work. In virtually all situations, if there is a mold issue, there is or has been an excessive moisture issue. Visible signs of mold or mildew (such as discoloration) can indicate the presence of mold or mildew on the subfloor, on the underlayment, on the back of the flooring, and sometimes even on the floor surface. If mold or mildew is discovered during the removal or installation of resilient flooring, all flooring work should stop until the mold/mildew problem (and any related moisture problem) has been addressed. Before installing the new resilient flooring, make sure the underlayment and/or subfloor is allowed to thoroughly dry and that any residual effect of excessive moisture, mold, or structural damage has been corrected.

To deal with mold and mildew issues, you should refer to the U.S. Environmental Protection Agency (EPA) guidelines that address mold and mildew. Depending on the mold or mildew condition present, those remediation options range from cleanup measures using gloves and biocide to hiring a professional mold and mildew remediation contractor to address the condition. Remediation measures may require structural repairs such as replacing the underlayment and/or subfloor contaminated with mold and mildew as a result of prolonged exposure to moisture.

The EPA mold guidelines are contained in two publications "A Brief Guide to Mold, Moisture and Your Home" (EPA 402-K-02-003) and "Mold Remediation in Schools and Commercial Buildings" (EPA 402-K-01-001). Appendix B of the "Mold Remediation in Schools and Commercial Buildings" publication describes potential health effects from exposure to mold, such as allergic and asthma reactions and irritation to eyes, skin, nose and throat. These publications can be located on EPA's website at www.epa.gov/iaq/molds



Design & Construction Standards

OSHA REQUIREMENTS

In August 1994, OSHA published revised asbestos standards which affect some of the operations described in this booklet. OSHA has determined that intact resilient floor covering materials can be removed under a "negative exposure assessment" in compliance with the revised standards by appropriately trained workers using the Recommended Work Practices.

- "Intact" is defined to mean that the asbestos-containing material has not crumbled, been pulverized, or otherwise deteriorated so that it is no longer likely to be bound with its matrix. The incidental breakage of flooring materials, or slicing of sheet vinyl floor covering with a sharp-edged instrument, during removal operations conducted in accordance with the Recommended Work Practices does not mean that the materials are not removed in an "intact" condition. OSHA has recognized that resilient floor covering materials are considered nonfriable if intact and generally do not emit airborne fibers unless subjected to sanding, sawing or other aggressive operations.
- Installers of resilient floor covering materials that plan to use the Recommended Work Practices outlined in this book to remove intact and nonfriable asbestos-containing flooring materials are required to complete an 8-hour training program.
- Employers must designate a "competent person" with 4 hours of additional training to be responsible for the health and safety of the workers at the floor removal job site.
- OSHA has determined that the competent person can make a "negative exposure assessment" based upon data in the OSHA asbestos rulemaking record (including data from the Environ Reports) showing that use of the Recommended Work Practices during removal of intact flooring material consistently results in worker exposures below the levels permitted in the OSHA standards.
- Where other workers or persons may have access to the flooring removal worksite, the employer must establish a demarcated "regulated area" (e.g. using barrier tape or closing room doors to enclose a work area) and post warning signs.
- Workers who engage in the removal of asbestos-containing flooring materials for more than 30 days per year (one hour or more per day) must receive medical surveillance.
- Employers are required to maintain certain training and workplace and medical records.



Design & Construction Standards

EPA LEAD-BASED PAINT REQUIREMENTS

Effective July 6, 2010, EPA has established training, certification, and work practice requirements for paid renovation, repair, or remodeling work that disturbs more than 6 square feet of lead-based paint per room within a 30 day period in a home (e.g. single-family, apartments) or a facility occupied by children under age of 6 (e.g., daycare center, preschool) built prior to 1978. 40 C.F.R. § 745.80 et seq. In these pre-1978 facilities, it is assumed that any painted surfaces contain lead paint, unless EPA-approved testing is performed to show that the disturbed surfaces are lead-free.

The removal or installation of resilient flooring in these pre-1978 buildings may involve disturbing or removing molding, baseboards, or floors (e.g., wood) that have been painted with lead-based paint or cutting off the bottom of painted doors or molding to allow the new floors to fit. To determine whether more than 6 square feet in a room is disturbed, multiply the total length of the disturbed painted material by its height (both numbers in feet). For example, if a 4 inch high baseboard (1/3 foot) is being removed as part of an installation or removal, over 18 linear feet of this baseboard would have to be removed to trigger the rule (1/3 foot x 18 feet = 6 square feet). For more examples, see <http://www.epa.gov/lead/pubs/rrp-faq.pdf>.

If the rule is triggered the following training, certification, and work practices are required:

- Employees performing the work must have completed a lead-safe work practices training course of 8 hours in length approved by EPA, which training is valid for 5 years. See http://cfpub.epa.gov/flpp/searchrrp_training.htm for approved courses in each state.
- The firm performing the work must be lead-safe certified by EPA, which requires the submission of an application and fee to EPA. The application fee is typically \$300 for a five year certification and it may take up to 90 days to process the application. The application procedures for each state can be found at the link in the paragraph above.
- Before beginning work, your firm must: (1) notify the residents of the affected homes or the parents of the affected children by providing the EPA Renovate Right pamphlet (<http://www.epa.gov/lead/pubs/renovaterightbrochure.pdf>); and (2) must maintain its notification records for 3 years.
- Your firm and employees must use lead-safe work practices, including posting warning signs; isolating the work area with plastic sheeting or other materials; removing or covering furniture; cleaning and inspecting the worksite when the work is finished; and disposing of any waste in a safe manner.

Some states operate their own lead-based paint programs and may have more stringent requirements than the EPA rule. See <http://www.epa.gov/lead/pubs/renovation.htm#states> for a list of states with their own rules.



Design & Construction Standards

GENERAL RULES FOR REMOVAL OF RESILIENT FLOOR COVERING

When following the Recommended Work Practices there are several general rules to follow:

Never sand, dry scrape, drill, saw, beadblast, or mechanically chip or pulverize any resilient flooring, backing, lining felt, asphaltic "cutback" adhesive, or other adhesive to remove them from the floor. See "Warning Statement" on page one.

- Unless positively certain the product you intend to remove is a non-asbestos-containing material, you must presume it contains asbestos. Regulations may require that the material be tested to determine asbestos content.
- Removal of existing floor covering should be considered the last alternative.
- Use a vacuum equipped with HEPA filter, disposable dust bag, and metal floor attachment (no brush).
- All sheet floor removals must be done using detergent solution.
- All felt scraping must be done wet.
- Prior to removal, all tile must be wetted (except in cases where heat will be applied).
- Do not dry sweep.
- Material removed must be placed in heavy-duty impermeable bags at least 6 mils thick or in a leak-tight container, properly labeled and disposed of in an authorized landfill.



Design & Construction Standards

ALTERNATIVES TO REMOVAL OF EXISTING RESILIENT FLOOR COVERINGS

Removal of the in-place resilient floor should be considered the final alternative. It is preferred you leave the existing resilient floor covering in place and go over the top (single flooring layer only) with the new floor.

Alternatives to the removal of an existing resilient floor over approved subfloors are:

- Installing directly over a single layer of approved existing resilient flooring.
- Filling the embossing of the in-place resilient flooring with embossing leveler before installation (residential use only).
- Covering existing resilient flooring on an approved suspended wood subfloor with a recommended wood underlayment.

When you plan to install a new resilient sheet or tile floor covering over an existing resilient floor covering, follow the installation instructions published by the manufacturer. Those instructions will tell you what must be done to the existing surface before the new resilient floor covering can be installed. Remove wax and other finishes by wet stripping only.

Contact a local established floorcovering dealer for additional information.



Design & Construction Standards

REMOVAL OF RESILIENT SHEET FLOORING

Supplies and Tools

- Safety glasses and gloves
- Stiff-bladed wall or floor scraper
- Utility or hook knife
- Tank-type High Efficiency Particulate Air (HEPA) wet/dry vacuum cleaner with disposable dust bag and metal floor attachment (no brush)
- Hand-held tank sprayer
- Large-size heavy-duty impermeable trash bags (at least 6 mils thick) or closed leak-tight containers with ties, tape, or string to tie the bags shut, and appropriate labels stating, for example "Caution— Contains Asbestos. Avoid Opening or Breaking Bag or Container. Breathing Asbestos is Hazardous to Your Health"
- A liquid dishwashing detergent which is stated to contain anionic, nonionic and amphoteric surfactants. Mix this specified liquid dishwashing detergent with water to make a dilute solution (16 oz. specified liquid dishwashing detergent in one gallon of water)
- Ground fault circuit interrupter for electrical connection of the HEPA vacuum and any other electrical connections required





Design & Construction Standards

REMOVAL OF FULLY-ADHERED RESILIENT SHEET FLOORING

WARNING

Do not sand, dry sweep, dry scrape, drill, saw, beadblast or mechanically chip or pulverize existing resilient flooring, backing, lining felt, asphaltic "cutback" adhesive, or other adhesive. See "Warning Statement" on page one.

- Remove all furniture and appliances from the work area.
- Remove any binding strips or other restrictive moldings from doorways, walls, etc.
- Prepare the specified liquid dishwashing detergent solution (16 oz. of specified liquid dishwashing detergent to one gallon of water) and pour into a hand sprayer.
- Before removal begins, vacuum the entire floor using a HEPA vacuum with a metal floor attachment.

WARNING

Electrical shock hazard exists. Use a ground fault interrupter for any electrical connections of equipment used in a wet environment

- Make a series of parallel slices 4" to 8" apart through the top layer of the flooring and about halfway through the backing, parallel to the wall, for the entire floor.

WARNING

Resilient flooring becomes slippery when wet with the specified liquid dishwashing detergent solution. Use caution to contain the solution in the immediate work area.

- **Wear layer removal:** One worker starts at the end of the room farthest from the entrance door and pries up the corner of the strip, separating the backing from the wear layer. As the strip is being removed, another worker sprays a constant mist of the specified liquid dishwashing detergent solution into the delamination nip point to minimize any airborne dust particles. When done properly, the felt remaining on the floor and on the back of the strip will be thoroughly wet. Do only one three-strip area at a time. Stand on the remaining floor covering or clean floor (to the extent feasible, minimize standing on the felt). The sliced strips should be peeled from the backing by pulling or rolling around a core which will control the stripping angle to create a uniform tension (some resilient flooring wear layers may not be readily strippable and may require wet-scraping). Tie or tape the removed material securely and place in the heavy-duty impermeable trash bag or closed leak-tight container for disposal.



Design & Construction Standards

- Remove and dispose of each succeeding strip in the above manner. Minimize walking on the exposed felt to the extent feasible. Worker footwear must be cleaned or removed before leaving work area. Close full bags tightly, and seal securely for disposal. Identify with an appropriate label stating, for example "Caution—Contains Asbestos. Avoid Opening or Breaking Container. Breathing Asbestos is Hazardous to Your Health." Dispose in an approved landfill only.

- Occasionally, parts of the top or inner layer will stick to the backing. This can often be eliminated by peeling in the opposite direction. The stiff-bladed scraper may aid in the removal or peeling of these layers.

- Wet-scraping residual felt:

- (1) After three strips of flooring material are removed, any residual felt must be wet scraped. Thoroughly wet the residual felt with the specified liquid dishwashing detergent solution. Wait a few minutes to allow the specified liquid dishwashing detergent solution to soak into the felt.

- (2) Stand on the remaining floor covering to the extent feasible (not the felt) and use the stiff bladed scraper to scrape up the wet felt.





Design & Construction Standards

(3) Rewet the felt if the specified liquid dishwashing detergent solution has not completely penetrated, if drying occurs, or if dry felt is exposed during scraping. Pick up the scrapings while still wet as they are removed from the floor and place in a heavy-duty impermeable trash bag or leak-tight container. Wet-scrape all felt from this floor area before proceeding further.

PRECAUTION:

Excessive moisture can cause permanent damage to wood underlayments. It is the installer's responsibility to use the correct amount of specified liquid dishwashing detergent solution to prevent underlayment damage. A floor that has been wet-scraped must be allowed to dry before installing any new resilient flooring.

(4) When this floor area has been cleaned free of felt, vacuum with HEPA vacuum cleaner with the metal floor attachment. Position the vacuum cleaner so that the discharge air does not blow on the area being cleaned.

(5) Repeat the above on the next series of strips.

(6) Repeat this operation until the felt has been removed from the whole floor. Close full bags tightly and seal securely for disposal. Identify with an appropriate label stating, for example "Caution—Contains Asbestos. Avoid Opening or Breaking Bag or Container. Breathing Asbestos is Hazardous to Your Health." Dispose in an approved landfill only.

(7) When the entire floor has been removed, let it dry and vacuum with HEPA vacuum cleaner with the metal floor attachment. Position the vacuum cleaner so that the discharge air does not blow on the area being cleaned.

(8) After vacuuming, used HEPA filters and cleaner bags should be removed according to the manufacturer's instructions and placed in a heavy-duty impermeable trash bag or leaktight container with an appropriate label stating, for example "Caution—Contains Asbestos. Avoid Opening or Breaking Bag or Container. Breathing Asbestos is Hazardous to Your Health." Close and seal the trash bag securely for disposal. Dispose in an approved landfill only.

(9) The floor is now ready to have a new resilient floor covering installed. Follow the manufacturer's installation instructions.



Design & Construction Standards

REMOVAL OF UNADHERED (LOOSE-LAY) OR PERIPHERALLY-ADHERED RESILIENT SHEET FLOORING

WARNING

Do not sand, dry sweep, dry scrape, drill, saw, beadblast, or mechanically chip or pulverize existing resilient flooring, backing, lining felt, asphaltic "cutback" adhesive, or other adhesive. See "Warning Statement" on page one.

- Remove all furniture and appliances from the work area.
- Remove any binding strips or other restrictive moldings from doorways, walls, etc.
- Prepare the specified liquid dishwashing detergent solution (16 oz. of specified liquid dishwashing detergent to one gallon of water) and pour into a hand sprayer.
- Before removal begins, vacuum the entire floor using a HEPA vacuum with a metal floor attachment.

WARNING

Electrical shock hazard exists. Use a ground fault interrupter for any electrical connections of equipment used in a wet environment

- If flooring is unadhered, start at the end of the room farthest from the entrance doorway and slice a strip 18" wide in the unadhered flooring. One worker removes the sliced strip while another worker sprays the specified liquid dishwashing detergent solution directly into the separation nip point. Minimize standing on the exposed subfloor during the removal process to the extent feasible.

CAUTION

Resilient flooring becomes slippery when wet with specified liquid dishwashing detergent solution. Use caution to contain the solution in the immediate work area. Standing on a new sheet of plywood or non-slip surface while working is recommended.



Design & Construction Standards

• Roll the wet strip tightly and tie or tape securely so it will not unroll. Place it in a heavy-duty, impermeable trash bag or closed leak-tight container big enough to accommodate several rolls for disposal.

Use this method for nonbonded areas of peripherally-adhered floors. To remove bonded areas, follow instructions under "Removal of Fully-Adhered Resilient Sheet Flooring."

• Clean the exposed floor with a HEPA vacuum cleaner with the metal floor attachment. Position the vacuum cleaner so that the discharge air does not blow on the area being cleaned.

• Repeat the above, slicing, rolling and disposing of one strip at a time and cleaning the newly exposed area immediately until the entire floor covering has been removed. Let the floor dry, then vacuum with a HEPA vacuum cleaner using metal floor attachment.

• After vacuuming, used HEPA filters and cleaner bags should be removed according to manufacturer's instructions and placed in a heavy-duty impermeable trash bag or leak-tight container with an appropriate label stating, for example "Caution—Contains Asbestos. Avoid Opening or Breaking Container. Breathing Asbestos is Hazardous to Your Health." Close and seal the trash bags or leak-tight container securely for disposal. Dispose in an approved landfill only.

• The floor is now ready for installation of new floor covering using the manufacturer's installation instructions.



Design & Construction Standards

REMOVAL OF RESILIENT TILE

Supplies and Tools

- Safety glasses and gloves
- Short or long-handled scraper (DO NOT USE SPUD BAR OR MECHANICAL CHIPPER)
- Hammer
- Commercial-type hand-held hot-air gun or a radiant heat source such as an infrared machine
- Large size, heavy-duty labeled, impermeable trash bags with minimum 6 mil thickness (or closed leak-tight containers), with ties, tape or string to tie shut, and tags for labeling
- Tank-type High Efficiency Particulate Air (HEPA) wet/dry vacuum cleaner with disposable dust bag and metal floor attachment (no brush)
- Hand-held tank sprayer
- Ground fault circuit interrupter for electrical connection of the HEPA vacuum and any other electrical connections required





Design & Construction Standards

REMOVAL PROCEDURE

WARNING

Do not sand, dry sweep, dry scrape, drill, saw, beadblast, or mechanically chip or pulverize existing resilient flooring, backing lining felt, asphaltic "cutback" adhesive, or other adhesive. See "Warning Statement" on page one.

- Remove all furniture and appliances from the work area. Remove any binding strips or other restrictive moldings from doorways, walls, etc.
- Before removal begins, vacuum the entire floor using a HEPA vacuum with a metal floor attachment.
- Floor tiles must be wetted (misted with hand sprayer) before actual removal begins (unless heat will be used to remove tiles).

WARNING

Electrical shock hazard exists. Use a ground fault interrupter for any electrical connections of equipment used in a wet environment.

- Those areas normally exposed to heavy foot traffic patterns usually have tiles adhered the tightest. In starting the tile removal process, select those areas which receive the least traffic. Try to remove individual tiles in one piece although some breakage of tiles is unavoidable.
- Start the removal by carefully wedging a short or long handled scraper in the seam of two adjoining tiles and gradually forcing the edge of one of the tiles up and away from the floor. Continue to force the balance of the tile up by working the scraper beneath the tile and exerting both a forward pressure and a twisting action on the blade to promote release of the tile from the adhesive and the floor.





Design & Construction Standards

- After the tiles are removed, place them, without further breakage, in a heavy-duty impermeable trash bag or closed leak-tight container which will be used for disposal. Removed tiles can be placed in empty tile cartons first and then placed in the heavy-duty impermeable trash bag. To prevent tearing of the heavy-duty impermeable trash bag, place only one full carton of removed tile in a bag.
- With the removal of the first tile, accessibility of other tiles is improved. Force the scraper under the exposed edge of another tile, and continue to exert a prying, twisting force to the scraper as it is moved under the tile until the tile releases from the floor. Remove and dispose of each tile in the manner described above.
- Minimize walking on the exposed adhesive to the extent feasible. Worker footwear must be cleaned or removed before leaving work area. Close full bags tightly and seal securely for disposal. Identify with an appropriate label stating, for example "Caution—Contains Asbestos. Avoid Opening or Breaking Container. Breathing Asbestos is Hazardous to Your Health." Dispose in an approved landfill only.
- Some tiles will release quite easily while others require varying degrees of force. Where the adhesive is spread heavily or the tile is bonded tightly, it may prove easier to force the scraper under the tightly adhered areas by striking the scraper handle with a hammer, using blows of moderate force while maintaining the scraper at a 25° to 30° angle to the floor.

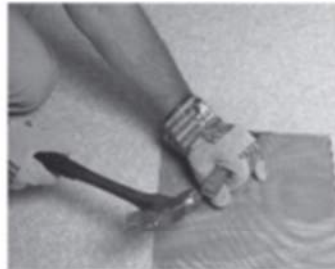

CAUTION

Wear safety glasses when using this procedure.

- If you encounter areas where even the above methods will not remove the tiles, the removal procedure can be simplified by thoroughly heating the tiles



Design & Construction Standards

with a hot air gun or a radiant heat source until the heat penetrates through the tile and softens the adhesive.

• Alternatively, without first prying up floor tiles using a scraper, a heat source like a hot air gun or infrared heat machine can be used to apply heat to the floor tiles and then the tiles may be removed by hand or by using a scraper. (Wetting the tiles is not required for this alternative removal method). When using this procedure, walking on exposed adhesive may be unavoidable. Worker footwear must be cleaned or removed before leaving the work area.

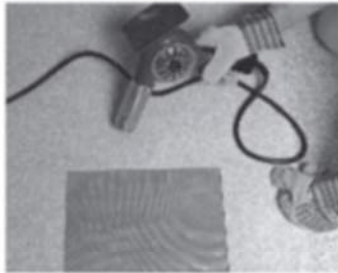

CAUTION

Handle the hot-air gun or radiant heat source carefully to avoid burn injury. Do not handle the heated tiles or adhesive without suitable glove protection. Do not use a blowtorch or open flame. Use caution not to burn or char tiles. Work area must be adequately ventilated.





Design & Construction Standards

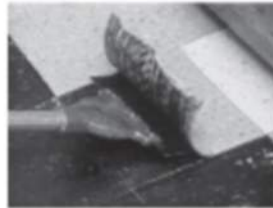
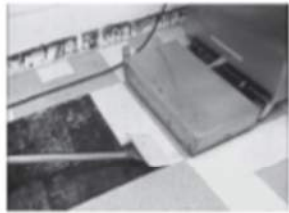

- When using an infrared heat machine, follow manufacturer's instructions.
- After tiles are removed, place them in a heavy-duty impermeable trash bag or other closed leak-tight container without further breakage. Removed tiles can be placed in empty tile cartons first and then placed in the heavy duty impermeable trash bags. To prevent tearing of the heavy-duty impermeable trash bag, place only one full carton of removed tile in a bag.
- Close the full bags of removed tile tightly and seal securely for disposal. Identify with an appropriate label stating, for example "Caution— Contains Asbestos. Avoid Opening or Breaking Container. Breathing Asbestos is Hazardous to Your Health." Dispose in an approved landfill only.

WARNING

Do not sand, dry sweep, dry scrape, drill, saw, beadblast, or mechanically chip or pulverize existing resilient flooring, backing, lining felt, asphaltic "cutback" adhesive, or other adhesive. See "Warning Statement" on page one.

- See Section 5, "Removal of Residual Adhesives" for proper treatment of remaining adhesive.



Design & Construction Standards

REMOVAL OF RESIDUAL ADHESIVE

The removal of latex based adhesives commonly used with vinyl sheet floors and some tiles can be accomplished by wetting the adhesive residue (which will soften the adhesive) and scraping. Do not use an excessive amount of water which can damage wood subfloors.

The treatment of residual asphaltic "cutback" adhesive, which is covered in this section, is dependent upon the type of new resilient floor covering material to be installed and the type of subfloor. Recommendations for the treatment of residual asphaltic "cutback" adhesive are shown on pages 21 through 26.

NOTE

There are commercial adhesive removal products containing solvents that are effective in removing cutback or emulsion adhesives and comply with OSHA requirements (e.g. flashpoint greater than 140° F). These products may be used for adhesive removal; however, they may leave a solvent residue within the subfloor that can adversely affect the new adhesive or floor covering. Thus, the warranties provided by the manufacturers of new floor covering materials will not cover instances where subfloor conditions damage their products or affect their installation.

The use of asbestos encapsulants or bridging materials over asphaltic adhesive is not recommended as those products may affect the bonding properties of the new adhesive. The application of asphaltic "cutback" adhesives, if recommended by the replacement flooring manufacturer, has been demonstrated to be a suitable adhesive when applied over existing cutback adhesive. The use of any new adhesive must be consistent with the installation recommendations of the replacement-flooring manufacturer.

Supplies and Tools

- Safety glasses and gloves
- Stiff-bladed wall or floor scraper
- Tank-type High Efficiency Particulate Air (HEPA) wet/dry vacuum cleaner with disposable dust bag and metal floor attachment (no brush)
- Large-size, heavy-duty, impermeable trash bags (or closed leak-tight containers) with ties, tape, or string to tie the bags shut, and tags for labeling.
- Slip-resistant shoes or rubber boots
- Ground fault circuit interrupter for electrical connection of the HEPA vacuum and any other electrical connections required
- Hand-held sprayer



Design & Construction Standards



- A liquid dishwashing detergent which is stated to contain anionic, nonionic and amphoteric surfactants. Mix this specified liquid dishwashing detergent with water to make a dilute solution (1 oz. of the specified liquid dishwashing detergent to one gallon of water)
- Floor machine fitted with 3M black floor pad (or equivalent)
- Removal solution—e.g. "mop on, mop off, no machine scrub," tripping solution
See note on page 21 regarding use of other solutions
- Water-absorbent material





Design & Construction Standards

RESIDUAL ASPHALTIC "CUTBACK" ADHESIVE				
CONCRETE SUBFLOOR			WOOD UNDERLAYMENT SUBFLOOR	
New Material to Be Installed	Removal of Residual Adhesive	Alternative to Removal	Removal of Residual Adhesive	Alternative to Removal
Resilient floor tile to be installed using cutback adhesive.	Residual adhesive must be wet-scraped so that no ridges or puddles are evident and what remains is a thin, smooth film. See wet-scraping of residual adhesive.	Application of a cementitious underlayment that is approved by the underlayment manufacturer for use over residual asphaltic "cutback" adhesive. ¹	The use of a cutback adhesive over wood underlayment subfloor is not recommended.	The use of a cutback adhesive over wood underlayment subfloor is not recommended.
Resilient floor tile to be installed using an adhesive other than cutback adhesive.	Residual adhesive must be wet-scraped so that no ridges or puddles are evident and what remains is a thin, smooth film. See wet-scraping of residual adhesive.	Application of a cementitious underlayment that is approved by the underlayment manufacturer for use over residual asphaltic "cutback" adhesive. ²	Complete removal of Wood Underlayment. See Complete Removal of Wood Underlayment Under Existing Tile.	Covering residual asphaltic "cutback" adhesive on an approved wood subfloor with a recommended wood underlayment. ² When installing this new wood underlayment, felt or polyethylene sheeting may be placed over the residual adhesive to prevent a cracking or tacky sound when walking on the floor.
Any vinyl-backed sheet flooring	100% of the residual adhesive must be removed from the area to be covered. See removal of residual adhesive.	Application of a cementitious underlayment that is approved by the underlayment manufacturer for use over residual asphaltic "cutback" adhesive. ²	Complete removal of Wood Underlayment. See Complete Removal of Wood Underlayment Under Existing Tile.	Covering residual asphaltic "cutback" adhesive on an approved wood subfloor with a recommended wood underlayment. ² When installing this new wood underlayment, felt or polyethylene sheeting may be placed over the residual adhesive to prevent a cracking or tacky sound when walking on the floor.
Felt-backed sheet flooring.	Enough of the residual adhesive must be removed so that 80% to 100% of the original substrate of the overall area is exposed. ¹ See removal of residual adhesive.	Application of a cementitious underlayment that is approved by the underlayment manufacturer for use over residual asphaltic "cutback" adhesive. ²	Complete removal of Wood Underlayment. See Complete Removal of Wood Underlayment Under Existing Tile.	Covering residual asphaltic "cutback" adhesive on an approved wood subfloor with a recommended wood underlayment. ² When installing this new wood underlayment, felt or polyethylene sheeting may be placed over the residual adhesive to prevent a cracking or tacky sound when walking on the floor.

¹ Amount of adhesive which must be removed varies. Check with manufacturer of replacement felt-backed sheet flooring for requirements.

² All warranties and/or guarantees concerning underlayment's performance rest with the underlayment manufacturer and not with the resilient floor covering manufacturer.



Design & Construction Standards

WET-SCRAPING RESIDUAL ADHESIVE

WARNING

Do not sand, dry sweep, dry scrape, drill, saw, beadblast, or mechanically chip or pulverize existing resilient flooring, backing, lining felt, asphaltic "cutback" adhesive, or other adhesive. See "Warning Statement" on page one.

If new resilient floor tile is to be installed over a concrete subfloor using an asphaltic adhesive, the residual asphaltic "cutback" adhesive must be left so that no ridges or puddles are evident and what remains is a thin, smooth film. This can be accomplished by wet-scraping the residual adhesive.

Wet-Scraping residual asphaltic "cutback" adhesive:

- Moisten an area with water mixed with the specified liquid dishwashing detergent (1 oz. specified liquid dishwashing detergent to one gallon of water) to aid in wetting the adhesive. Make sure that the area stays moist. Wet-scrape with a stiff-bladed wall or floor scraper removing ridges and any loose adhesive. Make sure the adhesive is kept wet.
- Place loosened adhesive residue into a heavy-duty impermeable trash bag or leak-tight container with an appropriate label stating, for example: "Caution—Contains Asbestos. Avoid Opening or Breaking Container. Breathing Asbestos is Hazardous to Your Health." Close and seal the trash bag securely for disposal. Dispose in an approved landfill only.
- Wet vacuum standing water with the HEPA vacuum cleaner.
- Continue above steps until what remains of the residual asphaltic "cutback" adhesive is a thin, smooth film.
- Clean the entire floor with the HEPA vacuum cleaner using the metal floor attachment.
- After vacuuming, used HEPA filters and cleaner bags should be removed according to manufacturer's instructions and placed in a heavy-duty, impermeable trash bag or leak tight container with an appropriate label stating, for example: "Caution—Contains Asbestos. Avoid Opening or Breaking Container. Breathing Asbestos is Hazardous to Your Health." Close and seal the trash bags or containers securely for disposal. Dispose in an approved landfill only.





Design & Construction Standards

COMPLETE REMOVAL OF ASPHALTIC "CUTBACK" ADHESIVE

WARNING

Do not sand, dry sweep, dry scrape, drill, saw, beadblast or mechanically chip or pulverize existing resilient flooring, backing, lining felt, asphaltic "cutback" adhesive, or other adhesive. See "Warning Statement" on page one.

REMOVAL METHOD

- Start in corner of the room farthest from the entrance door. Apply the removal solution (e.g. "mop on, mop off, no machine scrub," stripping solution) by using a hand sprayer or mop over an area of residual adhesive so that the adhesive in this area always remains wet during its removal. Allow the area to soak for 5-10 minutes. Remove the adhesive using a floor machine equipped with a 3M black floor pad (or equivalent), ensuring that the floor is kept wet in the area where the machine is operating.

WARNING

Electrical shock hazard exists. Use a ground fault circuit interrupter for any electrical connections of equipment used in a wet environment.

- Occasionally push away the adhesive slurry from the subfloor with a wall or floor scraper or squeegee to check for complete removal. Continue to use the floor machine, equipped with black pad, in the same area until the concrete subfloor is cleaned to the degree necessary for the new floor installation.

- Adhesive around the edge of the room and in areas that were missed or difficult to reach with the machine can be removed with a hand-held piece of the black floor pad using the above procedures.

WARNING

Electrical shock hazard exists. Use a ground fault interrupter for any electrical connections of equipment used in a wet environment.



Design & Construction Standards



- Wet HEPA vacuum the adhesive slurry. When the HEPA vacuum is full, place commercially suitable water absorbent into the HEPA container until the adhesive slurry is absorbed. An absorbent material may be used on the slurry to absorb the adhesive residue. Place the adhesive waste from the HEPA vacuum or floor into heavy-duty, impermeable bags or leak-tight containers with an appropriate label stating, for example "Caution—Contains Asbestos". Avoid Creating Dust. Breathing Asbestos May Cause Bodily Harm." Close and seal the trash bag securely for disposal. Dispose in an approved landfill only.
- Rinse floor area with clean water using a hand sprayer or mop. Worker footwear should also be cleaned and rinsed.
- Wet-vacuum standing water with HEPA vacuum cleaner.
- Continue above steps until the entire room is complete.
- Allow subfloor to dry and vacuum with a HEPA vacuum with metal floor attachment.
- Minimize walking on the wet adhesive to the extent feasible. Worker footwear must be cleaned or removed before leaving the work area.



Design & Construction Standards

COMPLETE REMOVAL OF WOOD UNDERLAYMENT

Supplies and Tools

- Safety glasses and gloves
- Chisel
- Hammer or mallet
- Short and long-handled pry bars
- Utility or hook knife
- Stiff-bladed wall or floor scraper
- Large-size, heavy-duty, impermeable trash bags (or leak-tight container) with ties, tape, or string to tie the bag shut and tag for labeling
- Tank-type High Efficiency Particulate Air (HEPA) wet/dry vacuum cleaner with disposable dust bags and metal floor attachment (no brush)
- Hand sprayer
- A liquid dishwashing detergent which is stated to contain anionic, nonionic and amphoteric surfactants
- 6-mil polyethylene sheeting
- Duct tape
- Ground fault circuit interrupter for electrical connection of the HEPA vacuum and any other electrical connections required
- For tile removal only—Commercial-type, handheld, hot-air gun or a radiant heat source such as infrared machine





Design & Construction Standards

COMPLETE REMOVAL OF WOOD UNDERLAYMENT (SUBFLOOR) UNDER EXISTING SHEET FLOORING

WARNING

Do not sand, dry sweep, dry scrape, drill, saw, beadblast, or mechanically chip or pulverize existing resilient flooring, backing, lining felt, asphaltic "cutback" adhesive, or other adhesive. See "Warning Statement" on page one.

- Remove all furniture and appliances from the work area.
- Remove any binding strips or other restrictive moldings from doorways, walls, etc.
- Prepare the specified liquid dishwashing detergent solution (16 oz. of specified liquid dishwashing detergent to one gallon of water) and pour into a hand sprayer.
- Before removal begins, vacuum the entire floor using a HEPA vacuum with a metal floor attachment

WARNING

Electrical shock hazard exists. Use a ground fault interrupter for any electrical connections of equipment used in a wet environment.

- Starting at the doorway or a floor ventilation vent, locate a joint in an underlayment board.
- Slice a strip of flooring 4 to 8 inches wide centered over the underlayment joint in the panel to be removed. Slice through the top and inner layers of flooring and about halfway through the backing. Continue this procedure for all underlayment joints over the entire floor.

CAUTION

Resilient flooring becomes slippery when wet with specified liquid dishwashing detergent solution. Use caution to contain the solution in the immediate work area.

- One worker pries up the corner of a strip, separating the backing from the wear layer. As the strip is being removed, another worker sprays a constant mist of the specified liquid dishwashing detergent solution into the delamination nip point to minimize any airborne dust particles. When done properly, the felt remaining on the floor and on the back of the strip will be thoroughly wet. Stand on the remaining floor covering or clean floor (do not stand on the felt).



Design & Construction Standards

The sliced strips should be peeled from the backing by pulling or rolling around a core which will control the stripping angle to create a uniform tension (some resilient flooring wear layers may not be readily strippable and may require wet-scraping). Tie or tape the removed material securely and place in a heavy-duty, impermeable, trash bag or closed leak tight container for disposal.

- Remove and dispose of each succeeding strip in the above manner. Minimize walking on the exposed felt to the extent feasible. Worker footwear must be cleaned or removed before leaving work area. Close full bags tightly, and seal securely for disposal. Identify with an appropriate label stating, for example "Caution—Contains Asbestos. Avoid Opening or Breaking Container. Breathing Asbestos is Hazardous to Your Health." Dispose in an approved landfill only.
- Occasionally, parts of the top or inner layer will stick to the backing. This can often be eliminated by peeling in the opposite direction. The stiff bladed scraper may aid in the removal or peeling of these layers.

WARNING

Do not sand, dry sweep, dry scrape, drill, saw, beadblast, or mechanically chip or pulverize existing resilient flooring, backing, lining felt, asphaltic "cutback" adhesive, or other adhesive. See "Warning Statement" on page one.

- Remove all furniture and appliances from the work area.
- Remove any binding strips or other restrictive moldings from doorways, walls, etc.
- Prepare the specified liquid dishwashing detergent solution (16 oz. of specified liquid dishwashing detergent to one gallon of water) and pour into a hand sprayer.
- Before removal begins, vacuum the entire floor using a HEPA vacuum with a metal floor attachment
- Wet-scraping residual felt—follow instructions for wet-scraping residual felt on Page 12.
- For procedures for removing wood underlayment boards see Page 32.



Design & Construction Standards

COMPLETE REMOVAL OF WOOD UNDERLAYMENT (SUBFLOOR) UNDER EXISTING TILE FLOORING

- Before removal begins, the entire floor is vacuumed using a HEPA vacuum with a metal floor attachment.

WARNING

Electrical shock hazard exists. Use a ground fault interrupter for any electrical connections of equipment used in a wet environment.

- Floor tiles must be wetted (misted with hand sprayer) before actual removal begins (unless heat will be used to remove tiles).

WARNING

Resilient flooring becomes slippery when wet with the specified liquid dishwashing detergent solution. Use caution to contain the solution in the immediate work area.

- Starting at the doorway or a floor ventilation vent, locate a joint in an underlayment board.
- Start the removal of the tile at the underlayment joint by carefully wedging the scraper in the seam of two adjoining tiles and gradually forcing the edge of one of the tiles up and away from the floor. Do not intentionally break off pieces of the tile, but continue to force the balance of the tile up by working the scraper beneath the tile and exerting both a forward pressure and a twisting action of the blade to promote release of the tile from the adhesive and the floor. Continue to remove tiles in this manner at all underlayment joints until all board joints are exposed.
- After the tiles are removed place them, without further breakage into smaller pieces, in a heavy-duty impermeable trash bag or closed leak-tight container which will be used for disposal. Removed tiles can be placed in empty tile cartons first and then placed in heavy-duty, impermeable, trash bags. To prevent tearing of the heavy-duty, impermeable, trash bag, place only one full carton of removed tile in a bag.
- With the removal of the first tile, accessibility of the other tiles is improved. Force the scraper under the exposed edge of another tile, and continue to exert a prying, twisting force to the scraper as it is moved under the tile until the tile releases from the underlayment. Remove and dispose of each tile in the manner above. Minimize walking on the exposed adhesive to the extent feasible. Worker footwear must be cleaned or removed before leaving area. Close full bags or leak-tight container tightly and seal securely for disposal. Identify with an appropriate label stating, for example "Caution—Contains Asbestos. Avoid Opening or Breaking Container. Breathing Asbestos is Hazardous to Your Health." Dispose in an approved landfill only.



Design & Construction Standards

- Some tiles will release quite easily while others require varying degrees of force. Where the adhesive is spread heavily or the tile is bonded tightly, it may prove easier to force the scraper through the tightly adhered areas by striking the scraper handle with a hammer, using blows of moderate force while maintaining the scraper at a 25° to 30° angle to the floor.
- If you encounter areas where even the above methods will not remove the tiles, the removal procedure can be simplified by thoroughly heating the tiles with a hot-air gun or a radiant heat source until the heat penetrates through the tile and softens the adhesive.
- When using automated infrared heating machines, follow the manufacturer's instructions.

WARNING

Handle the hot-air gun or radiant heat source carefully to avoid burn injury. Do not handle the heated tiles or adhesive without suitable glove protection. Do not use a blowtorch or open flame. Use caution not to burn or char tiles. Work area must be adequately ventilated.



Design & Construction Standards

REMOVAL OF WOOD UNDERLAYMENT BOARDS

WARNING

Do not sand, dry sweep, dry scrape, drill, saw, beadblast or mechanically chip or pulverize existing resilient flooring, backing, lining felt, asphaltic "cutback" adhesive, or other adhesive. See "Warning Statement" on page one.

• After all felt from sheet flooring has been wet-scraped or tiles removed from the underlayment joints, drive a chisel, using a hammer or mallet, between the underlayment board and the subfloor. Use the chisel to pry up the underlayment enough to insert a pry bar and remove the chisel. Slowly and carefully use pry bars to pry up the underlayment board a little at a time until the board is completely loose and can be removed.

• Caution must be used to avoid breaking the underlayment board. The underlayment board should be removed in one piece. If the underlayment board breaks, slice through the sheet resilient flooring at the break and spray any exposed felt with the specified liquid dishwashing detergent solution. Allow the specified liquid dishwashing detergent solution to penetrate for a few minutes, then continue lifting the broken underlayment. In the case of a broken underlayment board with tile adhered, wet (mist) the broken tile and carefully remove any loose pieces.

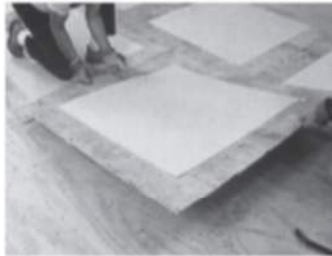

• Wear heavy gloves and be careful of wood splinters and fasteners sticking out of the back of the underlayment. Each underlayment board (or piece of board) should be removed from the work area as soon as it has been pried up to avoid injuries (such as stepping on a nail). Fasteners protruding from removed board should be flattened with a hammer. Place removed underlayment boards on skids with the nails pointing downward. Wrap skid with 6-mil polyethylene plastic sheeting and secure with duct tape. Identify with an appropriate label stating, for example "Caution—Contains Asbestos. Avoid Opening or Breaking Container. Breathing Asbestos is Hazardous to Your Health." Dispose in an approved landfill only.



Design & Construction Standards

- If the underlayment panel extends under cabinets or wall partitions, it will be necessary to slice through the flooring with a knife as close to the vertical surface as possible. Deeply score the panel. This should allow for removal.
- After each panel has been removed, pull out any nails or fasteners still in the subfloor.
- A chisel is not needed to start the removal of boards after the first board has been removed. Simply work the pry bar under the exposed edge of the next board.
- When removal of the underlayment under the existing floor is complete, thoroughly check the exposed subfloor. Renail loose areas and reset any "popped" nails or fasteners.
- Vacuum up any residue using the HEPA vacuum cleaner with the metal floor attachment.
- After vacuuming, used HEPA filters and cleaner bags should be removed according to the manufacturer's instructions and placed in a heavy-duty, impermeable, trash bag or leak-tight container with an appropriate label stating, for example "Caution—Contains Asbestos. Avoid Opening or Breaking Container. Breathing Asbestos is Hazardous to Your Health." Close and seal the trash bag or container securely for disposal. Dispose in an approved landfill only.
- Prepare the subfloor by installing new underlayment and or floor covering according to the manufacturer's installation instructions.



115 Broad Street, Suite 201
LaGrange, GA 30240
706.882.3833

October 2011

This book replaces all prior editions of the RFCI and Armstrong Recommended Work Practices publications. Future editions of these work practices may be issued to replace this publication.



Design & Construction Standards



115 Broad Street, Suite 201, LaGrange, GA 30240 | phone: 706.882.3833
fax: 706.882.3880 | www.rfci.com



Design & Construction Standards

02.30 Facilities Management Tree Preservation & Protection Standards

VCU Facilities Management Virginia Commonwealth University	
Technical Guidelines	
WHO SHOULD READ <ul style="list-style-type: none"> • Project Managers • Architect & Project Managers • Grounds Department 	TREE PRESERVATION AND PROTECTION
Draft, March 22, 2012	Table of Contents

Page 3		Associated Standard Details
Page 4	GENERAL -	Related Documents Description of Work Work Included in This Section Related Work Specified Elsewhere
Page 5	PRODUCTS -	Non-Woven Textile Fabric Woven Textile Fabric
Page 6	EXECUTION	Tree Protection Barricade Fencing Introduction Boring & Trenching Curb & Gutter Repair & Construction Sidewalk Repair & Construction
Page 7		Barricade Fencing Trunk Protection Temporary Access Root Zone Protection
Page 8		Fill Around Existing Trees Clearing Within Critical Root Zone Tree Damage Discontinuance of Work
Page 9		Root Pruning Pruning and Thinning of Existing Trees Tree Preservation Cleanup



Design & Construction Standards

VCU Facilities Management <small>Virginia Commonwealth University</small>	
Technical Guidelines	
WHO SHOULD READ <ul style="list-style-type: none"> • Project Managers • Architect & Project Managers • Grounds Department 	TREE PRESERVATION AND PROTECTION
Draft, March 22, 2012	Table of Contents

STANDARD DETAILS

<u>Standard Number</u>	<u>Title</u>
	Tree Protection Detail
	Bridging Tree Roots
	Temporary Tree Protection Detail
	Rock Chimney



Design & Construction Standards

VCU Facilities Management <small>Virginia Commonwealth University</small>	
Technical Guidelines	
WHO SHOULD READ <ul style="list-style-type: none"> • Project Managers • Architect & Project Managers • Grounds Department 	TREE PRESERVATION AND PROTECTION
Draft, March 22, 2012	Table of Contents

TREE PRESERVATION AND PROTECTION

PART 01 – GENERAL

A. Related Documents:

The General Provisions of the Contract, including General and Supplementary Conditions and General Requirements, apply to the work specified in this Section.

B. Description of Work:

Purpose:

The purpose of this section is to provide protection for existing trees on public and/or private property during University sponsored construction projects. VCU will ensure tree protection measures meet or exceed City code where it applies.

C. Work Included in this Section:

Construction of Tree Protection Barricades, Replacement of Damaged Trees, Pruning, Curb and Gutter Repair, Replacement and Construction, and Sidewalk Repair and Construction.

PART 02 – PRODUCTS

A. Non-Woven Textile Fabric:

A needle-punched nonwoven geo-textile composed of polypropylene fibers that form a network does not allow the fibers to shift. Examples of this type include Mirafi 140 NL, Thrace-LINQ 130 EX, or an approved equal. Fabric must be UV stabilized and resistant to most chemicals found in the soil, mildew and insect damage. Samples must be submitted and approved by the Project Manager. Product Physical Properties:



Design & Construction Standards

VCU Facilities Management <small>Virginia Commonwealth University</small>	
Technical Guidelines	
WHO SHOULD READ <ul style="list-style-type: none"> • Project Managers • Architect & Project Managers • Grounds Department 	TREE PRESERVATION AND PROTECTION
Draft, March 22, 2012	Table of Contents

Weight Minimum 4 oz/yd²
 Thickness Minimum 35 mils
 Grab Tensile Strength Minimum 90 lbs UV
 Resistance 70% (at 500 hrs)

B. Woven Textile Fabric:

Woven geo-textile fabric with a minimum tensile strength of 200 lbs. shall be used under 6 inches of washed stone or suitable alternative whenever construction traffic must pass over the root systems of existing trees in unpaved areas. Landscape Filter Fabric shall be Class 2 Filter Fabric as defined in the AASHTO M 288 Geotextile Specification.

Samples of Filter Fabric shall be submitted to the Project Manager for approval prior to installation.

Product Specification:

Type:	100% Polyester
Minimum Tensile Strength:	200 lb
Elongation:	15% Min.
Minimum Burst Strength:	400 psi
Minimum Puncture Strength:	80 lb
AOS (min/max):	30/130
Minimum Ultra Violet Exposure Strength:	140 lb
Fungus Resistance:	No Growth

Tree Protection Barricade Fencing:

Barricades shall be constructed of wood, in accordance with Part 03 B of these specifications. Orange safety fencing, three feet high, or a suitable alternative may be used in lieu of wood rails



Design & Construction Standards

VCU Facilities Management <small>Virginia Commonwealth University</small>	
Technical Guidelines	
WHO SHOULD READ <ul style="list-style-type: none"> • Project Managers • Architect & Project Managers • Grounds Department 	TREE PRESERVATION AND PROTECTION
Draft, March 22, 2012	Table of Contents

if approved by the Project Manager. The installation of orange construction fencing in the right-of-way shall not inhibit driver and/or pedestrian vision at driveways and/or street intersections.

PART 03 – EXECUTION

Trees designated for Tree Protection on VCU-funded or VCU-sponsored construction projects shall have their critical root zone protected by tree barricades installed according to the VCU Tree Protection detail and where applicable, by the use of the VCU Bridging Tree Roots detail, the VCU Temporary Tree Protection detail, the VCU Curb Placement at Existing Tree detail, and the VCU Rock Chimney detail.

When trees are located within the street right-of-way, they shall be protected from damage and/or removal per the VCU Tree Protection Standard and/or City requirements, whichever is greater. Trees located on VCU property shall be protected according to the VCU Tree Protection Standard. Any proposed construction adjacent to Public Right-of-Way involving trees or root systems in the Right-of-way should be approved by the City Arborist.

This includes the following: storm drainage, underground utilities, driveways, sidewalks, etc. The Grounds Superintendent shall review and approve construction plans for trees on VCU property.



Design & Construction Standards

VCU Facilities Management <small>Virginia Commonwealth University</small>	
Technical Guidelines	
WHO SHOULD READ <ul style="list-style-type: none"> • Project Managers • Architect & Project Managers • Grounds Department 	TREE PRESERVATION AND PROTECTION
Draft, March 22, 2012	Table of Contents

A. Boring and Trenching:

Open trenching, including pilot and/or receiving holes, closer to a tree than:

Trees Diameter (D.B.H.)	Radial Distance (feet)
-------------------------	------------------------

Less than 6	Limb spread
6" - 9"	5'
10" - 14"	10'
15" - 19"	12'
20" - 30"	15'
Over 30"	20'

will be considered harmful to the trees unless a boring construction method is performed. Any exceptions must be approved by the Project Manager in coordination with the Grounds Superintendent. Utilities may be tunneled in the root zone at a 24" minimum depth providing that plans are approved showing the location and method.

C. Curb and Gutter Repair and Construction:

When working to install curb and/or guttering within 10 feet of any tree (12 inches or larger in diameter), plywood forms or suitable alternative will be used. Clearing, grading, or digging will not be allowed beyond 6 inches from the proposed back of curb unless the Grounds Superintendent has provided approval. Root pruning will be in accordance with Tree Preservation and Protection Standards, Part 03-L, entitled "Root Pruning". If any portion of the trunk and/or root flare extends over the section being replaced, it cannot be damaged during construction even if a small portion of the old structure must be left in place.



Design & Construction Standards

VCU Facilities Management <small>Virginia Commonwealth University</small>	
Technical Guidelines	
WHO SHOULD READ <ul style="list-style-type: none"> • Project Managers • Architect & Project Managers • Grounds Department 	TREE PRESERVATION AND PROTECTION
Draft, March 22, 2012	Table of Contents

C. Sidewalk Repair and Construction:

When working within 10 feet of any tree 12 inches or larger in diameter, plywood forms or suitable alternative will be used. Clearing, grading, or digging will not be allowed beyond 6 inches from the proposed edge of the sidewalk unless the Grounds Superintendent has provided approval. Root pruning will be in accordance with Tree Preservation and Protection Standards, Part 03-L entitled "Root Pruning." If any portion of the trunk and/or root flare extends over the section being replaced, it cannot be damaged during construction even if a small portion of the old structure must be left in place. Narrow sections of sidewalk will be constructed in accordance with directions from the Project Manager and no less than 40 inches in width. Bridging of large roots will be in accordance with the VCU Bridging Roots detail.

D. Barricade Fencing:

Barrier fences shall extend around trunk as shown on Landscape the VCU Tree Protection detail to encompass the Critical Root Zone. So defined, it shall encompass the trees with a radius of not less than one foot (1') for every one inch (1") of trunk diameter (critical root zone) unless otherwise detailed in plans. When a circular or nearly circular area of this radius cannot be protected due to project design constraints, then an asymmetrical Critical Root Zone area shall be encompassed in the barricade fencing and shall be constructed around the tree which encompasses an equal area (square footage) of critical root zone. Barricade fencing shall not be placed closer than four feet (4'). Deviations from this must be approved on an individual basis by the Project Manager and Grounds Superintendent.

All tree protection barriers shall be installed prior to any grading or other land disturbing activity. They shall be constructed from any material substantial enough to designate the protected area and to protect the roots, trunk, and crown of the tree. Example: 2 x 4 standards and 1 x 4 rails; 3' high orange safety fencing, etc.



Design & Construction Standards

VCU Facilities Management Virginia Commonwealth University	
Technical Guidelines	
WHO SHOULD READ <ul style="list-style-type: none"> • Project Managers • Architect & Project Managers • Grounds Department 	TREE PRESERVATION AND PROTECTION
Draft, March 22, 2012	Table of Contents

E. Trunk Protection:

See VCU Temporary Tree Protection Detail. Batter boards and sand bags will be installed when working within 10 feet of any tree 12 inches or larger. The purpose of these items will be to protect the trunk or root flare from damage during construction.

F. Temporary Access:

Permission may be granted to allow temporary (30 days) access across the critical root zone.

Mulch 8 to 12 inches deep with woven geo-textile as specified in "Tree Preservation and Protection," Part 02 – Products, or approved equivalent laid underneath, shall be required in these areas to act as a cushion to prevent soil compaction. Mulch and fabric shall be removed after construction is complete.

G. Root Zone Protection

Tools, materials or machinery in any portion shall not be stored within the critical root zone.

H. Fill Around Existing Trees to Remain:

No fill dirt greater than two inches (2") shall be allowed over the critical root zone of the tree. Deviations from this must be approved on an individual basis by the Project Manager and Grounds Superintendent.

I. Clearing within Critical Root Zone:

In the critical root zone, the removal of any portions of old sidewalk, driveway, and/or curb shall be done with extreme care so as not to damage any portion of the branches, trunk, or roots.



Design & Construction Standards

VCU Facilities Management <small>Virginia Commonwealth University</small>	
Technical Guidelines	
WHO SHOULD READ <ul style="list-style-type: none"> • Project Managers • Architect & Project Managers • Grounds Department 	TREE PRESERVATION AND PROTECTION
Draft, March 22, 2012	Table of Contents

In the critical root zone, any stumps, dead trees and shrub growth to be removed shall be cut flush or ground out. Stump grinding will be performed only when necessary with appropriate equipment to a depth of 12 inches. All holes will be backfilled completely the same day of the operation. Stumps to be ground out will be designated by the Project Manager. No grubbing is permitted in the critical root zone areas.

J. Tree Damage:

Climbing irons, spurs or spikes shall not be used on trees to be pruned and are only allowed on trees to be removed. Any tree damage caused by the Contractor is to be repaired immediately at no additional expense and to the satisfaction of the University. Any damages resulting in the disfigurement and/or shortened life expectancy of a tree will be evaluated by the Grounds Superintendent. The entire value of the tree will be pro-rated by the loss of life expectancy and that value assessed to the Contractor. Trees damaged beyond repair, as judged by the Grounds Superintendent, are to be removed at no expense to VCU, and replaced by trees of size and species designated at no additional expense to VCU; or the dollar value of such damaged trees as determined by the Grounds Superintendent is deducted from the monies owed the Contractor. The tree values will be determined by using the guidelines in the Tree Evaluation Guide by The International Society of Arboriculture.

A MINIMUM FINE OF \$50 WILL BE ASSESSED FOR EACH INCIDENT OF BARK AND CAMBIUM DAMAGE OF 4" WIDTH OR LESS WHERE RESTRICTIONS ARE VIOLATED. IF DAMAGE IS LARGER, DAMAGES WILL BE ASSESSED USING I.S.A. TREE EVALUATION GUIDE PROCEDURES. FINES WILL BE DEDUCTED FROM THE MONIES OWED THE CONTRACTOR.

K. Discontinuance of Work:

Any practice obviously hazardous to people or harmful to the trees, as determined by the University, shall be immediately discontinued by the Contractor upon receipt of either written or oral notice to discontinue such practice.



Design & Construction Standards

VCU Facilities Management <small>Virginia Commonwealth University</small>	
Technical Guidelines	
WHO SHOULD READ <ul style="list-style-type: none"> • Project Managers • Architect & Project Managers • Grounds Department 	TREE PRESERVATION AND PROTECTION
Draft, March 22, 2012	Table of Contents

L. Root Pruning:

Root pruning shall be kept to an absolute minimum. In no case shall any root be pruned that is 1 1/2 inches in diameter or greater without the express permission of the Project Manager or Grounds Superintendent.

All roots proposed to be cut shall be located in advance at a point 6-12" outside the proposed cut by using a shovel, a probe, a high-pressure stream of water, air excavation tool or other approved method. The cut is to be made no more than 6" behind the back of the curb, wall, or other structure to be built. Pruning shall only be performed to the minimum depth required for the structure. The roots shall be cut cleanly leaving a smooth surface. Root pruning equipment shall be kept sharp to ensure that roots are cut cleanly and are not broken or torn by dull or unsuitable equipment.

M. Pruning and Thinning of Existing Trees:

All pruning shall be in accordance with ANSI A300 for Tree Care Operations- Tree, Shrub, and Other Woody Plant Maintenance – Standard Practices.

N. Tree Preservation:

The Grounds Superintendent must approve all tree removals from VCU-owned property. The City Arborist must approve all tree removal from the City right-of-way. Signature of an authorized representative of the Grounds Superintendent or City Arborist on final construction plans and documents constitutes the express approval of the Grounds Superintendent or City Arborist.

O. Clean Up:

Remove all barriers upon completion of project and fill the holes left by vertical posts of fencing with suitable soil. Restore area to original condition.

END OF SECTION



Design & Construction Standards

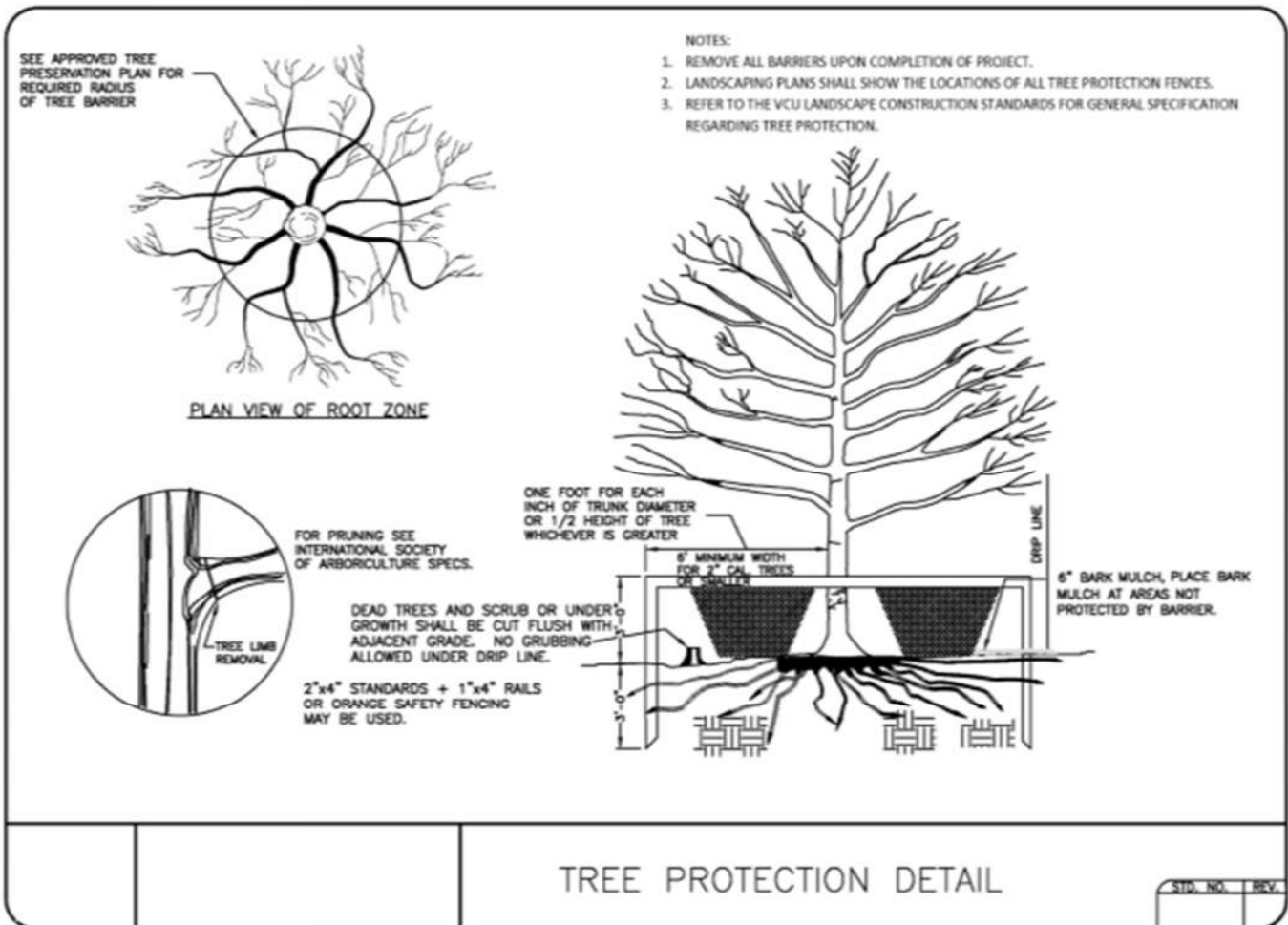



Design & Construction Standards

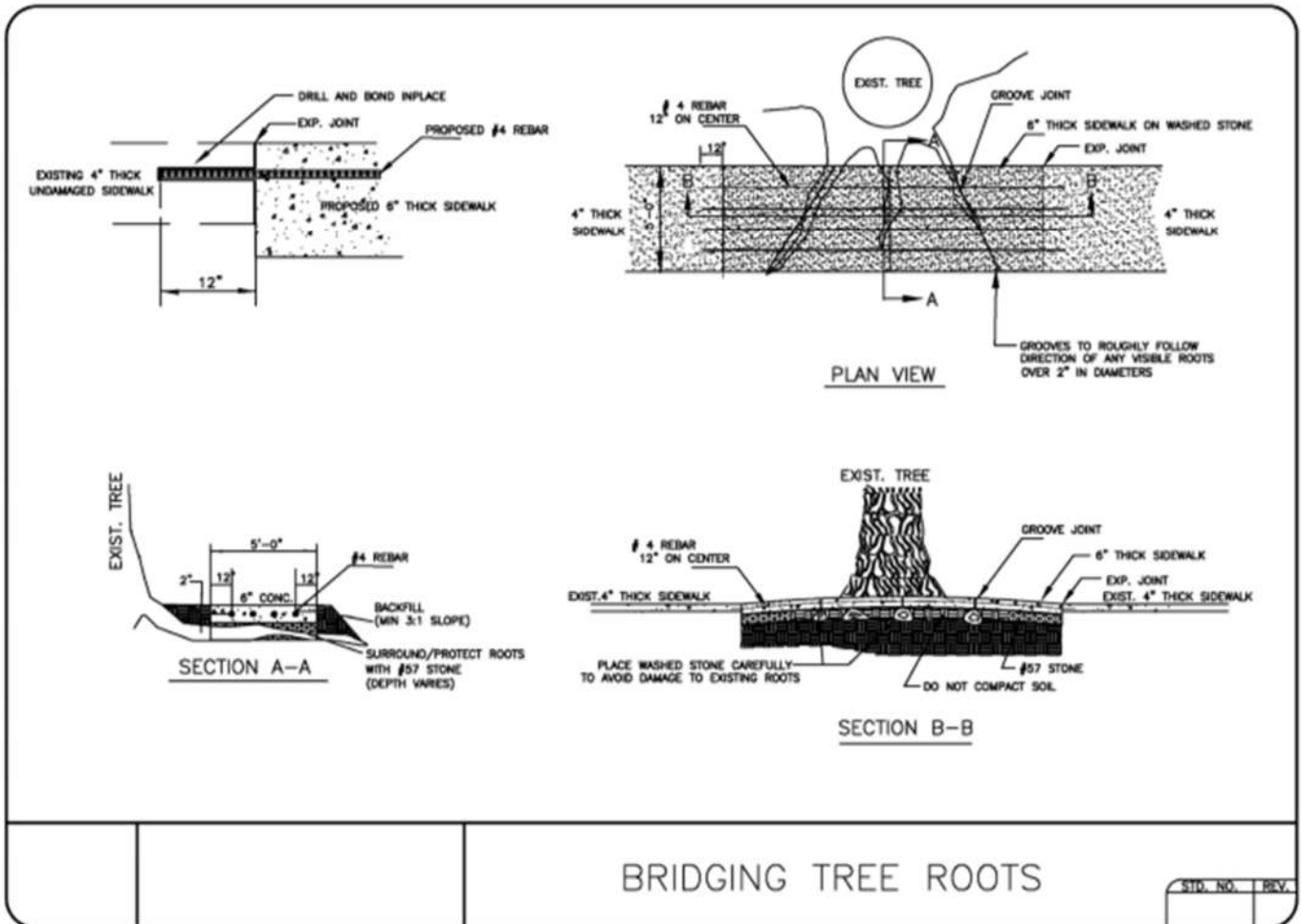



Design & Construction Standards

NOTES:

1. THIS TREE BUMPER DETAIL SHALL BE USED WHEN WORKING WITHIN 10' OF AN EXISTING TREE TO BE PROTECTED.
2. ALL TREES SHALL BE SAVED UNLESS NOTED OTHERWISE ON THE PLANS OR DIRECTED BY THE PROJECT MANAGER.
3. LUMBER, WIRE, SANDBAGS MAY BE REUSED AT OTHER TREES.
4. THE INTENT OF THIS DETAIL IS TO PROTECT EXISTING TREES FROM DAMAGE DURING CONSTRUCTION ESPECIALLY FROM BACKHOE ARM SWING. AN ALTERNATE APPROACH MAY BE USED IF APPROVED IN WRITING BY THE PROJECT MANAGER AFTER CONSULTATION WITH THE GROUNDS SUPERINTENDENT OR HIS DULY AUTHORIZED REPRESENTATIVE.

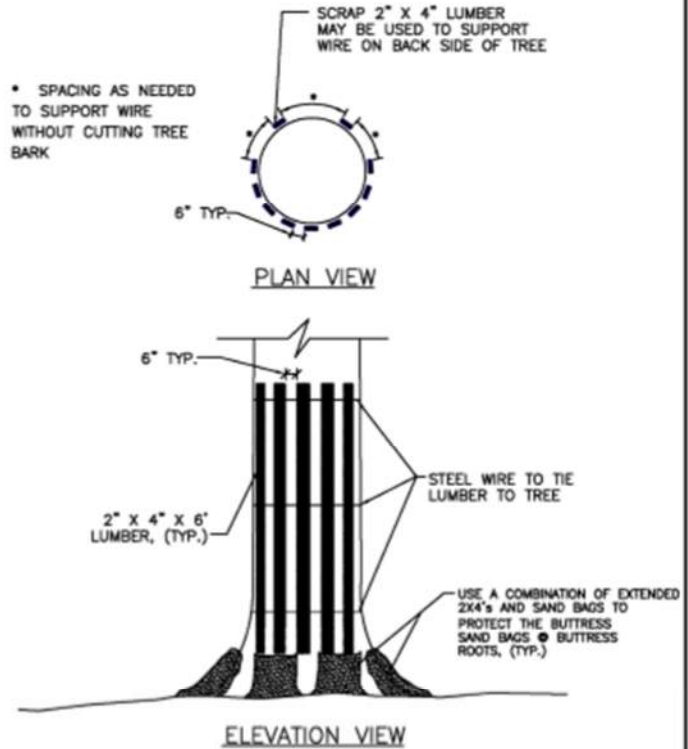

TEMPORARY TREE PROTECTION DETAIL

STD. NO.	REV.

01



Design & Construction Standards

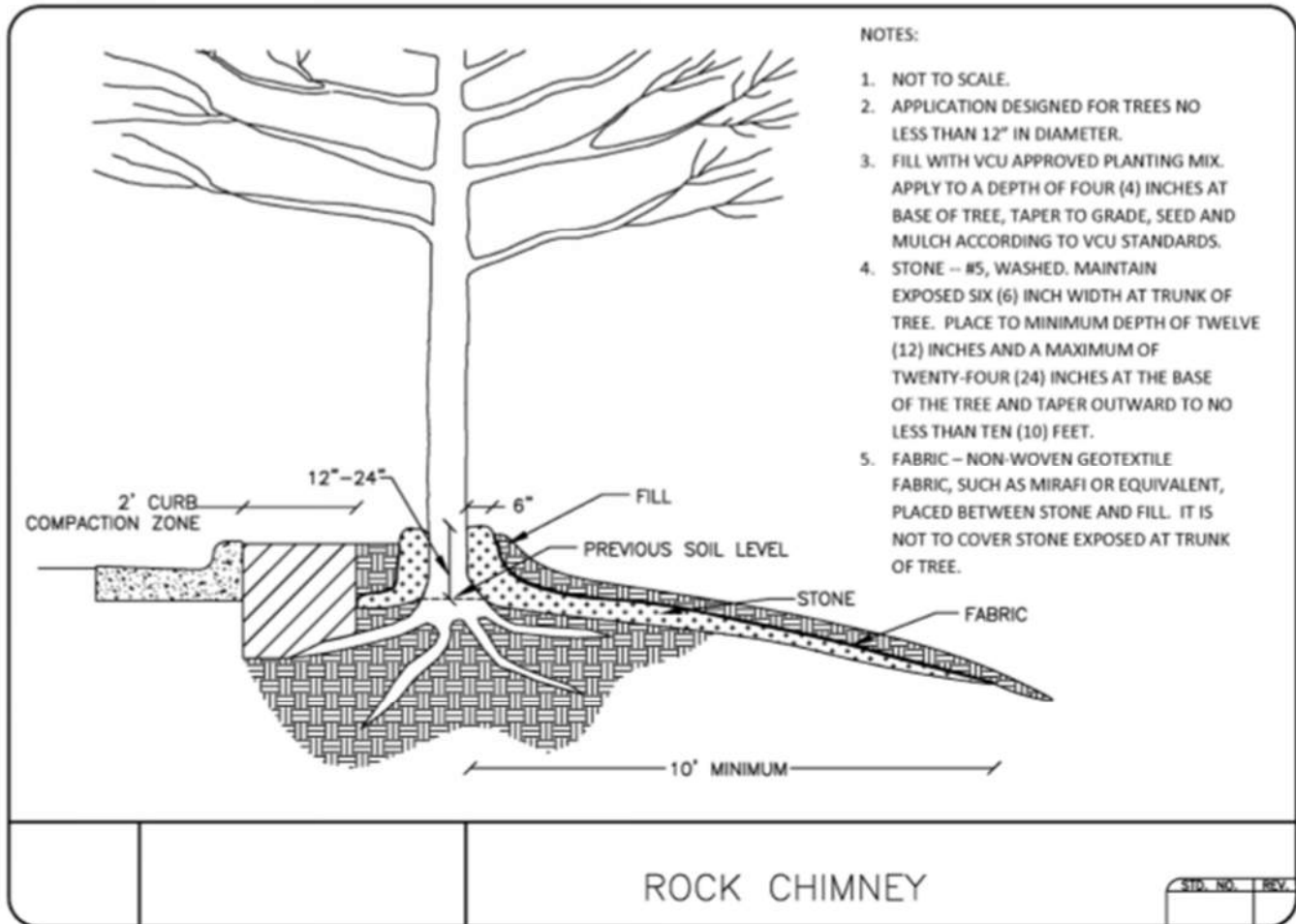

Design & Construction Standards

Division 03: Concrete

03.1 Concrete Formwork

- The CPSM contains requirements for cast-in-place concrete. These requirements must be incorporated into all projects. In case of a conflict between the standards herein and the CPSM, the CPSM shall take precedence.
- A comprehensive concrete placement specification should be used on all projects.
- Minimum concrete compressive strength shall be not less than 3,000 psi.
- Exposed aggregate surfaces shall not be used.

See CPSM § 6.3

ACI 301, Specification for Structural Concrete for Buildings (current edition) shall be incorporated by reference. "Comprehensive" project specific specifications include but are not limited to coordinating work, submittal requirements, mix designs, reinforcing criteria, placement tolerances, finish requirements, curing, testing and inspection criteria.

Quality Control Procedures

- The Project Inspector and or testing agency should establish a Standard Quality Control check list to monitor the placement and finishing of all concrete surfaces.
- Individuals performing the field tests of fresh concrete shall have proper training, qualifications, and be certified as a Concrete Field Testing Technician-Grade I by the American Concrete Institute (ACI) or other recognized entity.

See Section 1704.4 of the Virginia Construction Code (VCC) for minimum building code requirements for structural tests, and special inspections for concrete.

03.2 Concrete Reinforcement

Reinforcing Bars

- Comply with Concrete Reinforcing Steel Institute's (CRSI) recommended practice for the placing of reinforcing bars.

Design & Construction Standards

- Carbon fiber grid, also known as C-Grid, is not permitted in elevated slabs in parking decks

Secondary Reinforcement

- To control surface cracking in exposed concrete slabs, the use of polypropylene fibrillated fiber is encouraged and is acceptable for other exposed concrete, when approved in writing by the Facilities Management Division.
- Polypropylene fibrillated fiber is not a substitute for structural reinforcing and expansion and or contraction requirements.

03.3 Cast-in-Place Concrete

Finish Quality

- Even though finish quality is described in the specifications, it is critical that the project specifications require a pre-installation conference attended by the A/E, Project Manager, Project Inspector, Testing Firm, Contractor, and relevant Subcontractors review project requirements, and establish acceptable quality levels for all concrete surfaces prior to the placement of any concrete on the project.
- Attention is required to assure that flatness and levelness requirements are specified for concrete floors scheduled to receive finishes. The concrete specification must match the requirements of the finish material and subsequent construction.

Curing

- Wet – The use of wet curing is the preferred method.
- Curing compound: The use of a curing compound is to be limited where application of moisture is impractical. Such compounds shall not jeopardize the appearance of concrete, or bond to additional concrete. Further, curing compounds shall be used where concrete surface is to be finished with paint, tiles, waterproofing, roofing, or chemical seal. Compatibility with proposed finishes must be confirmed.

Design & Construction Standards

Curing compounds shall be used and applied with uniform thickness and other recommendations by manufacturers is type 1. When surfaces are exposed to sunlight, then type 2 curing compound shall be used.

03.5 Cementitious Decks & Toppings

Sidewalks

Design: All sidewalks at VCU should be designed to accommodate vehicular traffic load. Since many of the sidewalks are installed on City of Richmond property, the specifications must meet or exceed City of Richmond Standards. Otherwise, the minimum are as follows.

- 4000 PSI, air-entrained
- 6" minimum thickness
- Reinforced with 6 x 6 – W 1.4 x W 1.4 sheet
- Keyed contraction joints
- Doweled expansion joints

Sub slabs for brick pavers to meet same specifications as above, with the exception that thickness can be reduced to 4".

Finish: All sidewalks should have a perpendicular broom finish to the direction of travel after the edges have been framed. Tooled joints and edges.

Stair Treads & Landings

- Ensure that the placement and or screening method for stairwells and landings is uniform, flat, and or properly sloped. Stair treads are to slope down 1/8" per ft. interior, 1/4" per foot exterior, riser to nose. A screed template is to be used for stair treads to assure consistency.
- A/E should monitor and coordinate with the Project Manager to ensure that the requirements for floor finishes are acceptable on all concrete filled stairs. Bituminous paint is to be applied to concealed surfaces of nosings.

Strip Waterstops

- All waterstops shall be 3/4" x 1" and shall contain bentonite

Design & Construction Standards

material.

- Strip waterstops shall be used where they are shown on drawings, and where new concrete pours meet existing concrete or masonry surfaces.

Maintenance, Cleaning, & Tightening

- Forms and adjacent surfaces that will receive the concrete shall be thoroughly cleaned. Remove chips, wood, sawdust, dirt, or other debris just before placing concrete. Retighten forms and bracing before placing concrete, as required, to prevent mortar leaks and maintain proper alignment.

Penetrations & Openings

- Penetrations and openings shall be located on structural drawings. Penetrations and openings larger than 6" shall have appropriate diagonal reinforcement around them

End of Division 3

Division 04: Masonry

04.0 General

Stone & Brick Selection

- Preliminary Design Phase: In context with the surrounding buildings, the A/E shall select an acceptable brick, mortar and joint tooling, approved by the University Architect as part of the agreed design criteria.
- If fewer than three brick manufacturers and or mortars are selected, then performance specifications for size, type of brick, color, range, strength and permeability shall be used; citing as the basis of design one or more manufacturer's brick products. Mortar shall be selected and specified, likewise.
- The specifications shall require the Contractor to erect at least one, but no more than three sample wall panels size 4'-0" x 4'-0".
- The final selected and proposed bricks, mortar, masonry and or steel stud back-up, wall ties, insulation and limestone, and

Recommendation is to vary mortar colors a shade lighter and a shade darker on the initial three sample wall panels, to verify initial

Design & Construction Standards

or precast stone trim, flashing, including termination bars, and drip edges, etc., applicable to the project, shall be displayed in a mock-up wall panel size 4'-0" x 4'-0". This mock-up wall panel is separate from the sample panels, and is to be used to set standards for quality, along with final confirmation of exterior materials selection. A larger mock-up wall panel can be specified, however, variance from the standard size needs approval by the University Architect prior to incorporation into the contract document.

- The Architect of Record and University Architect shall review and approve the mock-up wall panel for workmanship and conformance prior to the materials order by the Contractor. The Architect of Record shall advise the University prior to approving or not approving a mock-up prior to notifying the Contractor.
- Additions to existing buildings shall match the existing mortar and brick in size, color, texture, and compressive strength, unless otherwise approved by the University Architect. The A/E is to clearly delineate an existing 4-foot square or greater wall area containing a minimum of 100 existing bricks to be matched, and include that information in the bid documents. The wall area location selected by the A/E shall be approved by the University Architect prior to bidding.

selection.

For large projects, consider an integrated wall mock-up that includes window openings, complete with framing and flashings.

04.1 Mortar & Masonry Accessories

Brick Types & Mortar

- All brick types, shapes, colors, and mortar type and color, shall be approved by the University Architect.
- Colored mortar shall be premixed; not jobsite mixed.
- Mortar admixtures must have both A/E and Facilities Management approval prior to specification and or usage.
- When the existing building has a historic significance as determined by the University, special attention shall be paid to the process of reviewing and approving the materials by the

Design & Construction Standards

University and the Virginia Department of Historic Resources (DHR), because the masonry design must comprehensively consider unit size, texture, color, patterns, mortar, and striking.

Masonry Accessories

- Concrete masonry control joints shall be built-in rubber type or grout keyed type, with face joint kept clear for installation of sealant.
- Dovetail slots and anchors shall be used for masonry veneer over concrete walls.
- Wire ties of pintle and eye-hook design shall be used for masonry veneer over concrete masonry or framed walls.
- Where required by seismic or wind-loading criteria, provide continuous horizontal wire reinforcement to secure brick veneer to wall ties.
- Weep holes for solid masonry shall be rope wicks.
- Weep and vent holes for brick veneer shall be manufactured vents. Do not use open head joints.
- Gauge and materials should be standard weight, hot-dip galvanized, or stainless steel.
- Mortar cavity drainage mesh should be used.
- Flashing should be 7-oz/ft². copper laminated flashing with hemmed metal drip edge, or sealant stop as approved by University Architect.
- Miscellaneous steel lintels, shelf angles, attachments, etc. embedded or incorporated into masonry construction, shall be hot-dipped galvanized or stainless steel. Exposed to view, e.g., window lintels, items are to be finished to match adjacent construction.

Clearly show locations and detailing of masonry control and expansion joints on drawings (elevations and floor plans). Reliance on specified location criteria is not recommended.

Clearly show locations and detailing of flashing on drawings. Show extent and alignment of flashing locations with other building elements, and openings on elevations. Indicate end dam locations.

Specify molten zinc galvanizing repair if necessary for cut or abraded miscellaneous steel embedded in masonry. Paint-type repairs or non-galvanized miscellaneous steel items are not acceptable.

04.2 Unit Masonry

Masonry Standard

Comply with the American Concrete Institute (ACI) 530.1 / American Society of Civil Engineers (ASCE) 6 / The Masonry Society (TMS) 602,

Specify additional requirements for installation and workmanship, such as tighter joint width

Design & Construction Standards

as referenced by the Virginia Construction Code (VCC) as the baseline standard. *tolerances as required.*

Veneer Masonry

Face brick and other masonry veneers shall be backed for their full extent with masonry units, or steel stud back-up as is appropriate for the building design and selected structural system.

Veneer Anchors

Specify veneer anchors capable of transferring horizontal wind loads through continuous insulation and sheathing materials to back-up structure.

Parapet Walls

Parapet walls up to 3' in height shall be flashed from coping to roofing. Parapet walls over 3' in height shall be faced with brick masonry, or other approved exterior material other than exposed concrete masonry.

Preference is for roofing membrane to extend up and over parapet, and to terminate to exterior face of wall.

04.9 Masonry Restoration & Cleaning

Water Repellant Coatings: Use of water repellant coatings on exposed above-grade masonry is prohibited.

This includes not selecting new masonry materials that require a field-applied sealer or coating for proper long-term performance.

End of Division 4

Division 06: Wood, Plastics, & Composites

06.0 General

Refer to Sustainability section for specific target goals.

See "Division 01 General Requirements" section, and specific project requirements.

Specify that panel products shall not be manufactured with binder resins, or adhesives that contain urea formaldehyde.

See "Division 18 Sustainability" section for specific use VOC limits, and list of prohibited chemicals.

Specify that field-use adhesives shall not contain urea formaldehyde, or excess Volatile Organic Compounds (VOC), as indicated for specific purpose.

See "Division 18 Sustainability" section for specific use VOC limits, and list of prohibited chemicals.

Design & Construction Standards

06.1 Rough Carpentry

Use the current (reduced) design values for Southern Yellow Pine as published by the Southern Pine Inspection Bureau.

This is an Interim requirement based upon 2012 updates of the building code standard referenced, and remains effective until the 2015 building code revision cycle incorporated the updated referenced standard.

06.2 Finish Carpentry

Do not use Polyvinyl Chloride (PVC) trim materials (i.e. Fypon).

VCU has experienced material failures due to excessive thermal movement of these types of materials, especially when painted in traditional dark historic colors.

Provide chair rail systems in rooms and spaces with seating located against a wall. Specify chair rail systems that provide a cleanable surface. When appropriate for the design, provide appropriate wainscot materials that can be similarly cleaned.

Typical examples include waiting rooms, conference rooms, and classrooms without fixed seating. May also be specified in "Division 10 Specialties" section.

Provide corner guards on outside corners within areas subject to typical traffic.

Examples include corridors, lobby spaces, classrooms, waiting rooms, and similar areas subject to traffic. Private offices, dorm rooms, and similar spaces would not require these features. May also be specified in Division 10.

06.3 Wood Treatment

Avoid use of treated wood materials to the greatest extent possible. If it must be used, comply with manufacturer's treatment recommendations regarding design value adjustment factors.

Consider alternative detailing and other more appropriate materials.

Provide hot-dipped galvanized and or stainless steel fasteners and connectors, typical for any type of treated wood.

Where preservative-treated wood is used, provide separation membrane between wood materials and metals.

Typical recommendation is a .030" thick high-temperature "peel and stick" membrane or similar



Design & Construction Standards

If fire-retardant materials must be used, confirm manufacturer’s treatment requirements regarding appropriate use, detailing, and environmental limitations.

06.4 Architectural Woodwork

All ornamental stair or other railing systems shall be specified using standard, easy to replace parts.

*flashing type material.
Polyethylene sheet is not recommended.
Confirm specific structural uses with VCU Project Manager, and Authority-Having-Jurisdiction (AHJ).*

Fabrications that can be easily replicated locally, or by on-site trade personnel are preferred. Custom fabricated components such as tempered glass used either as guard infill or to support rails, should not be used.

End of Division 6

Division 07: Thermal & Moisture Protection

07.0 General

Storm Water Drainage

Provide storm water drainage that connects directly to storm water management facilities, without “daylighting” drainage across paved or landscaped areas.

See “Division 18 Sustainability” section for suggested water harvesting strategies and practices.

07.2 Insulation

Multi-story wall assemblies utilizing combustible foam plastic insulation (either board or spray-applied), shall comply with requirements of NFPA 285 (National Fire Protection Association) when tested as an assembly.

*See VCC Chapter 26.
Note: Constructed assemblies must not deviate from tested assemblies.*

Provide design and detailing to completely separate foam plastic insulations from the interior of the building, with appropriate thermal barriers.

Roof insulation shall achieve a minimum of an R-30 rating, for both flat and sloped roofs.

Design & Construction Standards

07.3 Steep Slope Roofing

Provide lead-coated copper or terne-coated stainless steel for counter flashing, cleats, drip edges, exposed metal trim, and or ridge cap, cant strips, and exposed metal valleys, typical.

Snow guards are required for all roofs with a slope of 6" - 12" or greater, and over all entrances regardless of slope. A minimum of three staggered rows is required. Snow guards shall be copper, stainless steel, or bronze butterfly type. Adhered plastic snow guards are not acceptable. Wire snow guards are acceptable only with specific project approval by the Roofing Project Manager.

See "Division 7 Flashing and Sheet Metal" section for roof drainage items.

Confirm design and layout of snow guard system as appropriate for size and slope of roof. Larger roofs may require intermediate rows of snow guards.

07.5 Low Slope Roofing

Specific project approval by the Roofing Project Manager is required for the use of the following:

- Phenolic foam insulation (board and spray-applied).
- Organic fiberboard insulation, including use as tapered edges.
- Non-structural glass mat face, non-combustible, water-resistant treated gypsum core panels in ballasted roof systems.

Vapor retarders shall have a perm rating of 0.5 or below, in accordance with ASTM E96 (American Society for Testing and Materials). Typically, two-ply organic membranes are recommended under hot applied system; a polyethylene sheet under single plies. Maximize insulation value to conserve energy; avoid insulation containing formaldehyde, ammonium sulfate, or foams expanded with Hydrochlorofluorocarbons (HCFCs); consider insulation with recycled content.

Polyisocyanurate board insulation shall have a nominal average compressible strength of 25 psi. Material provided shall be labeled to show compliance with this requirement.

Maximum single board thickness for flat insulation shall be 2".

Board insulation shall be installed with a minimum of two layers. The first layer shall be set with the long joints in a straight line, and the end joints staggered in running bond. Subsequent layers shall be

Design & Construction Standards

applied in the same manner with the joints staggered from the first layer to prevent thermal bridging. Fit boards together with no gaps to achieve a complete thermal envelope.

Chlorinated Fluorocarbons (CFCs) are permitted in insulation blowing agent only, with specific project approval by the Roofing Project Manager.

Pull tests shall be required for all mechanical fasteners. Mechanical fasteners may be used for post-tensioned concrete decks, or pre-stressed concrete panels subject to specific project approval by the roofing Project Manager.

07.6 Flashing & Sheet Metal

All buildings shall have a positive means of conducting rainwater from the roof to an underground storm water system. On sloped roofs, adequately sized and securely installed gutters and downspouts of minimum 16 oz. copper shall be specified, unless otherwise established by Facilities Management.

A minimum slope of 1/16" per foot for gutters shall be required. A minimum of two downspouts for each drain area shall be provided. Downspouts shall be securely fastened to the vertical plane, emptying into a cast iron boot at grade connected to a storm water system. Down leader protective baskets shall be provided to keep leaves away from drain inlets in gutters. Built-in or concealed gutters are discouraged for new construction.

Built-in metal gutter liner shall be terne-coated stainless steel, non-magnetic, with both sides coated with a terne alloy. Minimum thickness shall be 0.015" (28 gage). Built-in gutter liners shall have 3/4" wide formed expansion folds spaced every two linear feet prior to fabrication of gutter profile.

Built-in reglets shall be used for all wall-flashing terminations. Surface applied reglets shall only be used on existing buildings where installation of built-in reglets is not possible.

Solder all non-expansion joints in metal work.

Exposed metal shall be:

Design & Construction Standards

- Lead-coated copper, 16 oz. (0.216" thick) unless otherwise indicated
- Terne-coated stainless steel, non-magnetic sheet, both sides coated with terne alloy, minimum thickness of 0.015" (28 gage) unless otherwise indicated.

Copper sheet metal shall be used for flashing, scuppers, and eyebrow roof vents.

07.7 Roof Accessories & Specialties

Roof Access

Roof access for buildings less than 3 stories: Provide a 48" roof hatch with a ships ladder and an A frame hoist sized to lift at least 300 lbs.

- Roof hatches shall be insulated and feature thermally broken construction.
- Ships ladder shall be fixed, or if portable, shall be located where it is accessible and available at all times.
- Per OEHS Fire and Safety Department provide frangible (break away) type padlocks.

Roof access for buildings 4 or more stories: Provide a stair to the roof, with an oversize door (42") to the roof.

Note: For service access also provide an oversize (42") door at the ground floor level as well.

- An A-frame type hoist located near the alleyway, or other area shall be provided.
- For roofs greater than 6 stories, an elevator that opens level with the roof surface shall be required.
- Mechanical Penthouse Rooftop Enclosures — Refer to this subject on Page 161 of Section 23.0 to review additional rooftop guidelines.

07.9 Joint Seals

Color and appearance of joint seals shall be approved by VCU as part of the overall design review.

Use high quality 30+ years warranted products where possible.

Specify preconstruction and field adhesion testing where appropriate.

End of Division 7

Design & Construction Standards

Division 08: Openings

08.0 General Door & Frame Requirements

Durability

Doors and frames must be sturdy enough to resist racking associated with the placement of magnetic locks at the upper corner of the frame.

VCU has had trouble with the durability of some recently installed doors. This has been particularly problematic for tall storefront doors (over 7'-0") with magnetic locks. People will pull on the locked door and warp the door.

Possible solutions include:

- *Latching mechanism at the door handle*
- *Continuous hinges*
- *Latching at top and bottom*

For single doors, a possible solution is to install full length vertical housings, and locate two magnetic locks at the top and bottom corners on the lock edge. This would not work for a pair of doors. For severe use conditions consider specifying auxiliary overhead holders / stops and closers with enhanced back-check functionality.

Because of use of floor cleaning and ice-melting chemicals and difficulty of service and replacement, do not use floor mounted door closers or pivots.

Environmental Conditions

VCU has encountered several problems with doors being blown open and hinges being damaged by wind. Although not all wind conditions can be anticipated, there are some areas where we can reasonably assume these could be wind caused by a venturi effect. The Architect should take care to observe the microclimate and take into consideration the effects of wind pressures on door operations accordingly.

- All door closers must be equipped with a hydraulic back-check function or a brake.

Vestibules

To enhance energy efficiency the University requires that exterior doors be arranged as a vestibule or "airlock" to avoid excessive

For primary building entrances automatic sliding doors are preferred.

Design & Construction Standards

exchange of conditioned indoor and unconditioned outdoor air.

Access Control & Security

Typical access controlled exterior doors are provided with electro-mechanical hardware (electric strikes, electric-latch retraction, etc.) locking system. For normal operation, the mechanical exit device is disabled (crash bar is dogged open) and building access and door locking are controlled by the electro-mechanical hardware. In the event the access control system is taken out of service, the exit device is enabled to provide building security.

Architect / Engineer (A/E) Responsibility

The A/E shall be responsible for:

- Egress door operation code compliance
- Hardware coordination
- Specifying and indicating appropriate pathways / conduits for access control and Closed-Circuit Television CCTV systems.
- Conducting one or more meetings with representatives from VCU and the AHJ, coordinating and resolving conflicting requirements and showing requirements on the construction documents.

08.1 Metal Doors & Frames

Hollow metal door frames are preferred, unless existing building has wood frames. All hollow metal frames should be knock-down for interior renovations, and welded for new construction. Door frames fabricated from steel shapes shall not be used unless authorized. Specify A-40 (ZF 120) metallic coated steel sheet with factory primed finish after fabrication for standard interior door frames.

For high-traffic locations adjoining occupied such as a lobby incorporating a waiting area, consider the use of an air curtain located within the vestibule to reduce infiltration.

All exterior doors must be equipped with a mechanical locking system to secure out-of-service and vacant facilities.

Preference for access control and electronic locking systems, is to be equipped with uninterruptible power supply (UPS) battery back-up and connected to standby power system.

See additional information under "Division 28 Electronic Safety & Security" section.

In general, comply with Steel Door Institute (SDI) or Hollow Metal Manufacturers Association (HMMA) standards as appropriate.

VCU often wet-cleans flooring surfaces, and standard primed frames do not offer enough

Design & Construction Standards

Specify G-90 galvanized coating for high moisture interior and all exterior frames.

All steel frames shall be minimum 0.053", 1.3 mm, 16 ga. steel prior to application of metallic coating, reinforced for scheduled hardware. Reinforce all frames for door closers whether scheduled or not. Exterior metal frames shall be fully grouted.

Hollow steel doors shall be insulated.

Hollow metal exterior, stairwell, and other heavy use doors shall be minimum 0.053", 1.3 mm, 16 ga. face sheets. Other interior hollow metal doors shall be minimum 0.42", 1. mm, 18 ga. face sheets. Reinforce all doors for door closers whether scheduled or not. Stile reinforcement shall be at least 5" wide to accommodate standard mortise and cylindrical hardware. Specify standard 1 3/4" thick doors.

Exterior hollow metal doors shall have sealed inverted top channels and weeps.

Exterior door heights shall not exceed 8'-0".

08.2 Wood & Plastic Doors

Addressed by VCU Project Manager as needed.

corrosion resistance. The A-40 (aluminized) finish has replaced G-60 galvanizing as the industry standard for light-weight metallic coatings.

G-90 finish must be specified and may be a custom order. Typically not available factory primed; must be field primed.

Note: *Specify shop-applied asphaltic frame undercoating for surfaces of frames that will be in contact with grout.*

Corresponds to SDI "Extra Heavy Duty" for exterior and heavy use application, and SDI "Heavy Duty" for all other applications.

Expectation is that doors will be relocated and hardware will be replaced and or retrofitted over the useful life of the door.

Design & Construction Standards

08.3 Access Doors

This standard provides general guidance concerning the specific preferences for access doors and frames for ceilings, floors, and walls.

General locations:

- Access doors are to be provided for all maintenance points where immediate access is required.
- A/E is to specify that contractor shall coordinate trades to locate items needing maintenance access in grouped locations to minimize access doors.
- Contractor shall coordinate access door layout with VCU Project Representative in advance of constructing door(s).

Locking:

- Provide lockable access doors when they are located in public areas or where providing access to crawl spaces. Utilize Access Panels that will accept a mortise or rim cylinder. Cylinders and cores should be specified in accordance with the current lock standard, Section 08.7.

Minimum sizes: Coordinate with Specification Division 22, 23, and 26, and with specific job requirements.

- In wall, 20" x 20" square door: Plumbing valves, arrestors, hammers, reset buttons, controls manometers, clean-out ports, etc.
- In wall, 24" x 24" square door: Plumbing fittings at toilets, mechanical filters banks, access hatches, areas requiring work access for unit replacement, etc.
- In ceiling, 24" x 24" square door: Above ceiling cut-off valves, duct dampers, fire and/or smoke dampers, meters, registers, etc.
- In ceiling, 24" x 30" square door: HVAC filter units, remote duct dampers, remote fire dampers, remote electrical J-boxes, access hatches, etc.

For concealed dampers, provide extended operators to be easily reachable from access door.

Provide metal access doors with a powder-coated finish for panels located in non-lab/research areas.

All access doors located in research areas to be stainless steel.

All access doors in Department of Animal Research spaces to be stainless steel and utilize rubber seals in the opening to provide a tight seal. The outside perimeter of the door frame is to be caulked to the ceiling or wall.

Design & Construction Standards

Wires for electrified hardware must be in conduit.

All access doors located in a space that is subject to corrosives or chlorides to be a grade of 316 stainless steel. Door should have a seal around the opening and be sealed along the outer perimeter to the finished surface.

08.4 Entrances & Storefronts

Preference for main exterior entrance doors is for sliding automatic entrance doors.

Aluminum entrance doors should not exceed 7'-6" in height.

Aluminum entrance doors should have vertical stiles at least 6" wide, top and bottom rails at 8" wide, and center rail at least 8'-10" wide.

Do not use full-glass ("Hurculite") doors.

Do not use concealed closers; use surface mounted heavy duty closers with auxiliary door stops.

Provide for coordination between storefront installers, and electronic access control installers. All cabling must be fully concealed within framing members of completed installation.

08.4.2 Automatic Sliding Entrance Doors

Use of automatic sliding entrance doors for high-traffic areas is preferred. However, specify a push button operator (not motion detector) on the exterior for sliding doors fronting directly on sidewalks, to avoid unintended door operation triggered by passing pedestrian traffic.

Automatic sliding entrance doors shall be connected to standby power.

08.6 Roof Windows & Skylights

The use of skylight structures, unit skylights, and clerestory windows, shall be approved as part of the Schematic or Preliminary design process. VCU approvals include the Director of Planning & Design and or the Associate Vice President for Facilities Management.

Standard 7'-0" is preferred

Preference is for a door fabricated of standard extrusions capable of resisting racking and twisting.

Full-glass doors are easily damaged and difficult to secure, repair, and replace.

Traditional heavy duty surface mount closers are preferred for ease of service and repair.

Use concealed power transfers where necessary, to transfer power to door mounted hardware.

Entrances that are set back and protected from cross traffic may be equipped with customary motion detectors, if approved by the University.

Design & Construction Standards

When approved, skylights shall have exterior grills or guards to provide fall protection. Drawings and specifications for skylights or clerestory windows shall indicate dimensioning, flashing, sealants, gaskets, joints, and other quality criteria intended to prevent leaks and minimize maintenance. All skylights shall have a minimum 5" high curb on sloped roofs; 12" on flat roofs.

08.7 Hardware, Locks, & Access Control

Use the following standards on all projects. Do not match existing if it does not meet these standards.

All hardware shall be heavy-duty, commercial grade hardware.

Include a Primus full size interchangeable core (FSIC) as part of the door hardware for any keyed trim. Primus cores can be used with Schlage B600, B700, L, and ND series locks. 626 satin chrome finish.

Standard hinges are 5-knuckle ball bearing hinges, listed and labeled for fire door use. Do not use plain bearing hinges. Minimum size 4 1/2" x 4 1/2" with non removable pin (NRP)

Use continuous geared hinges for high-traffic locations, and for doors equipped with low-power operators.

VCU Physical Plant Lock shop does all keying

Operational Grade 1 hardware required.

Provide non-removable pins (NRP)



Design & Construction Standards

Schlage Mortise Lock





Design & Construction Standards

Use this Design



06

**Material: Forged brass,
bronze and cast stainless
steel**



Roses



A Wrought Rose
2 1/8" (54 mm) diameter
Available for use on L-Series
knob and lever designs.
Order by letter designation
corresponding to the design
and diameter desired.
Finishes: 605, 606, 609, 612,
613, 619, 625, 626, 629, 630,
643e



Cylindrical Locks: **Schlage ND Series**

Rhodes (RHO)

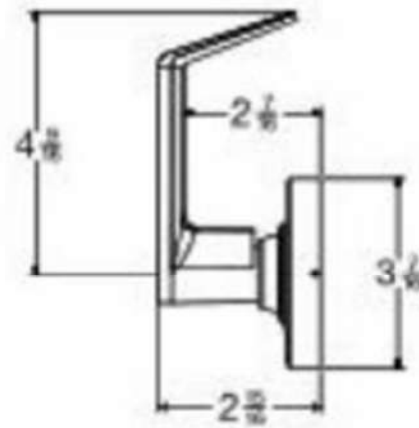
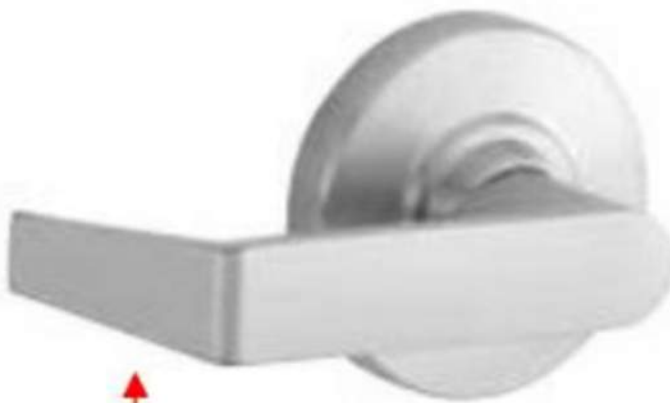

Material: Pressure cast zinc lever; wrought brass rose



Use This Design



Design & Construction Standards

Everywhere a key goes needs to have an Interchangeable Core!

Full Size Interchangeable Core 8

Schlage FSIC full size interchangeable core (IC) locksets allow immediate rekeying at the door simply by using a special control key to replace the core.



Available in all lever designs, full size interchangeable cores can be integrated into any 5 or 6-pin Schlage key.

Full Size Interchangeable Cores - Options

- Conventional core
- Primus XP high security core
- FSIC Driver

*Available in 606 and 626 finish only.
Everest 29 S123 keyway standard.*

Cylindrical locks need to come prepped for Interchangeable Cores. Mortise and Rim cylinder housings need to be provided where appropriate.



Design & Construction Standards

Von Duprin Exit Devices



Von Duprin exit devices are available in two external surface styles, designated 98 and 99 Series.

Use This Design





Design & Construction Standards

If Required:

Standard



Use This Outside Trim

Key locks and unlocks lever or knob. e.g., 996L (Classroom)

And This for dogging

CD Cylinder dogging



Cylinder dogging is available on all 98/99™ Panic exit devices to replace the standard hex key dogging. Unit requires a standard 1 1/4" (32mm) mortise cylinder with an inverted straight cam (Schlage Cam B502-191 reference).

To order, specify:

- Use prefix, CD, example CD99L

Design & Construction Standards

08.7.1 Low-Powered Operators

Although not required by the building code or by the Americans with Disabilities Act (ADA), VCU's policy provides at least one automatic door opener at each major public entrance on the new facility. If there are a series of doors, both doors in the series must have automatic openers.

Recommend the Record 8100 series control and operator or equivalent.

Automatic Door openers must be connected to standby power.

08.8 Glazing

- Window glazing shall not be patterned, but instead be a continuous monochromatic sheet. There shall be a clear border surround with application.
- All windows shall have an energy star rating. Double glazing shall be required, with a vacuum seal and low E-glass.
- Skylights shall be used sparingly.

08.9 Knox Box, First Responder Box & Key Center

- Knox Box: (required on new construction and major renovations)
 - For fire department use only
 - Dual key for Richmond FD and VCU Lock Shop
 - Recessed mount for new construction. Surface mount when recessed is not practical.



Design & Construction Standards



KNOXVAULT® 4400 DUAL LOCK MODEL

The KnoxVault 4400 is a secure, high capacity key lock box trusted by first responders, property owners, and universities. The dual lock capability allows for shared access. Store up to 50 keys, access cards and/or emergency plans to quickly gain rapid emergency access to large business and industrial facilities and campuses.



WEIGHT:	DIMENSIONS:
Surface Mount - 28 lbs	Surface Mount Body - 7"H x 7"W x 5"D
Recessed Mount - 29 lbs	Recessed Mount Flange - 9 1/2"H x 9 1/2"W

FEATURES

- ✓ Large capacity, storing up to a 50 keys. Access cards, entry items, emergency planning documents, and FDC Keywrench may also fit in interior compartment but will reduce max key quantity.
- ✓ Built Knox-Rugged and secure: UL 1037, UL 1610, UL 1332, UL 437
- ✓ Finished with Knox-Coat® to protect four times better than standard powder coat
- ✓ Extreme weather-resistant door gasket

BENEFITS

- ✓ Allows rapid property access
- ✓ Reduces property damage
- ✓ Prevents forced entry into buildings
- ✓ Minimizes first responder injury
- ✓ Compliant to National Fire Code (NFPA, IFC, IBC)

OPTIONS

- ✓ Knox Tamper Alert connects to building's alarm system for extra security
- ✓ Mount types: Recessed and Surface
- ✓ 3 color options: Black, Aluminum, Dark Bronze

ACCESSORIES

- ✓ Multi-Purpose Switch for use on electrical doors, gates and other electrical equipment
- ✓ Recess Mounting Kit for new concrete or masonry construction
- ✓ Public Safety Labels
- ✓ Tag-Out Tamper Seals
- ✓ Key Tags
- ✓ Key Rings

ORDERING SPECIFICATIONS

To insure procurement and delivery of the KnoxVault 4400, it is suggested that following specification paragraph is used:

KnoxVault surface/recessed mount with/without UL Listed Knox Tamper Alert. 1/4" plate steel housing, 5/8" thick steel door with interior gasket seal. Vault & lock UL Listed. Lock has 1/8" dust cover with tamper seal mounting capability. Vault has anti-theft re-locking mechanism with drill resistant hard-plate lock protector.

Exterior Dimensions: Surface Mount - 7"H x 7"W x 5"D
Recessed Mount Flange - 9 1/2"H x 9-1 1/2"W

Lock: UL Listed. Double-action rotating tumblers and hardened steel pins accessed by a biased cut key.

Finish: Knox-Coat® proprietary finishing process

Color: Black, Dark Bronze or Aluminum

P/N: KnoxVault 4400 (mfr's cat. ID)

Mfr's Name: KNOX COMPANY

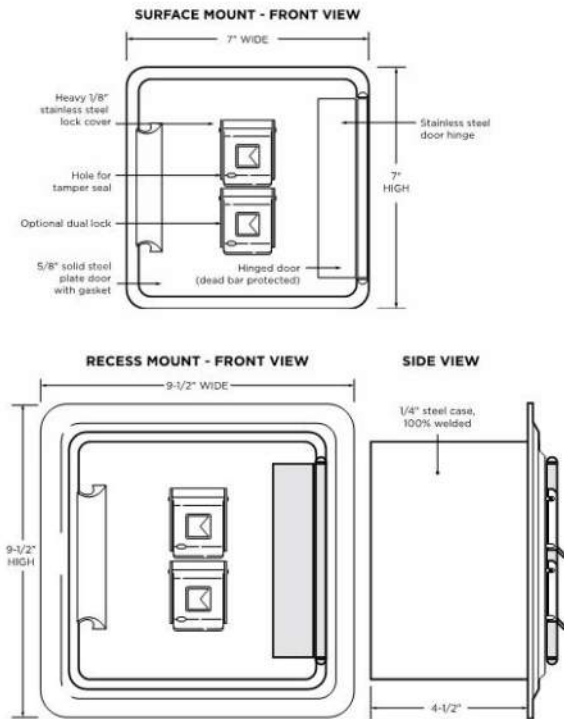

Design & Construction Standards

- First Responder Box (required on new construction and major renovations)
 - Contains master key/card for each floor.
 - Card access for VCU Police.
 - Possible at multiple locations on first floor. Consult with VCU Police on locations.
 - College of Health Professions is the standard

- Key Center (required on new construction and major renovations)
 - Contains all keys for a building/zone.
 - On E Power
 - On Access Control

End of Division 8

Division 09: Finishes

09.1 General

All products selected on any project shall meet LEED certification requirements. The level of certification will be decided per project. The most environmentally compliant finishes should be provided when possible.

All removed gypsum board partitions, acoustic ceiling systems, and carpet products shall be recycled to the greatest extent possible.

All products shall be readily available. Imported products may be used only with the approval of a VCU Project Manager.

Refer to “Division 18 Sustainability” standards document and project specific requirements.

Conditions of approval include but are not limited to demonstrated compliance with VCC requirements, and continued availability of products for maintenance purposes.

All products shall withstand heavy usage and be easy to maintain. Cleaning method specifications shall be provided to the VCU Project

Design & Construction Standards

Manager.

Attic Stock shall be provided for all products used on every project except paint.

The VCU Project Manager shall determine quantity of attic stock, and storage location.

09.2 Plaster & Gypsum Boards

Provide blocking and supplemental concealed supporting materials as required to adequately support suspended and supported items such as light fixtures, audio visual equipment, rails, grab bars, cabinets, and casework.

Verify noise isolation and acoustical privacy requirements, and show specific requirements on plans.

Fire rated construction shall comply with fire rated designs as indicated on plans, as approved by VCU and the designated building official.

Protect materials from moisture. Replace moisture or mold damaged materials.

Minimum acceptable finish for exposed to view and painted gypsum board is ASTM C840 Level 4. Provide Level 5 finish where required by manufacturer of high performance coatings and were directed by VCU Project Manager.

Level 5 may be either provided as a skim coat, or as a heavy-based primer designed to impart a Level 5 finish.

09.3 Tiling

No grouted tile floors anywhere without prior approval by VCU Project Manager

Epoxy grout is recommended for areas subject to staining, such as self-serve soda fountains and similar food service areas.

If approved for use, ceramic floor tile grout must always be sealed. Do not select or use white or light colors.

Specify appropriate installation materials for application in accordance with current Tile Council of North America (TCNA) installation methods, and associated American National Standards Institute (ANSI) standards.

Specify mortars with shear strengths, sag-resistance, and working times appropriate for tile size, type, and installation location.

For restrooms, tile the wet walls only with minimal grout joints.

Design & Construction Standards

09.5 Ceilings

Design and construct bulkheads and soffits of gypsum board supported on appropriate framing. Do not fabricate bulkheads from ceiling grid and acoustic ceiling panel materials.

Suspended ceiling grid module shall be 24" x 24", typical.

Specify and provide standard 15/16" wide grid unless otherwise directed by the VCU Project Manager.

If other grid types are provided, coordinate selection of lighting, HVAC diffusers, and other grid-mounted items for compatibility with specific grid provided.

Provide commercially available and locally stocked acoustic ceiling panels for standard use, per VCU stock items unless otherwise directed by VCU Project Manager.

Match existing in-use products within each building whenever possible. Verify availability of attic stock prior to bidding.

The following acoustic ceiling panel products are currently preferred:

- Armstrong Fissured Square Lay-in
- Armstrong Cirrus Angled Tegular
- Armstrong Cirrus Scored Classic Step Tegular
- Armstrong Cortega 704A

Where new product is required, attic stock is not available and a need for regular individual panel replacement is ongoing, consider replacing an entire room or space to create a new supply of attic stock from existing salvageable panels and components.

Provide upgraded tegular panels, 24" x 24", in upgrade use areas per direction of VCU Project Manager.

Current preference is for Armstrong "Optima" product.

Provide hold-down clips near exterior entrances and operable windows to prevent panel displacement by wind.

09.6 Flooring

Require that installer verify concrete slabs for acceptable moisture content, and pH levels prior to flooring installation.

Specify replaceable carpet tile type entry mats at entrance vestibules.

Do not specify recessed slat-type walk-off mats at vestibules.

Where feasible, building entrances protected by canopies are preferred.

Design & Construction Standards

Provide vinyl or rubber wall base in continuous roll with job-formed corners fabricated from same lot of running material, installed in each space. Wood base is not to be used in high traffic areas. Use of wood base to be approved by the VCU project manager.

Corners should be formed by reverse scoring if necessary, and bending without producing discoloration (whitening) at bends. Return dimension should be as long as practical, preferably a minimum of 12" from the corner to a running joint, to assure continued in-service adhesion of corner to substrate.

Terrazzo flooring systems shall be epoxy-resin types.

Provide a minimum of two coats of sealer and two coats of wax on all Vinyl Composition Tile (VCT).

Provide carpet tile, unless broadloom is approved by the VCU Project Manager.

If broadloom carpet is approved in lieu of carpet tile, provide product with an upgraded attached backing system.

Do not install carpet in below grade or basement locations unless specifically authorized by VCU Project Manager.

Do not specify or install a separate carpet pad, unless authorized by VCU Project Manager.

Allow adequate time for sufficient curing, drying, or settling of floor installations per the manufacturer's recommendations, prior to furniture and equipment installation.

For restrooms, terrazzo is the preferred flooring. Epoxy flooring is allowed on a case by case basis if approved by the VCU project manager and if allowed is to be turned up six inches at walls.

09.8 Acoustic Treatment

Bottom edge of acoustic wall panels shall be above seated head height, unless authorized by VCU Project Manager.

At locations subject to passing traffic and potential standing and leaning against wall surfaces, locate bottom edge of acoustic wall panels above head height. A suggested location is a few inches above top of prevailing door frame

Design & Construction Standards

height.

09.9 Painting & Coating

Require painting applicator to verify acceptability of surfaces to be prepared and painted. Specify appropriate preparation, including where necessary removal of existing finishes or coatings.

Provide high quality paint products with consideration of resins, binders, and pigments. Preferred products are Zolotone, Benjamin Moore and Sherwin Williams.

Provide a minimum of one primer coat and two finish coats on all rolled or brushed paint applications. Finishes (except in vivaria) to be as follows:

- Ceilings: Flat
- Walls: Eggshell
- Trim: Semi-gloss

Do not use low VOC epoxy paint

Provide one primer coat and three finish coats on sprayed paint applications.

Provide high performance paint at locations directed or specified by VCU Project Manager.

Provide a minimum 100 square foot test sample of each type and color of paint specified per project, for review and approval by VCU Project Manager.

Provide 5% additional product rounding-up to nearest full gallon for each type and color of painting specified on the project, for touch-up painting after project completion. Label cans with finish designations and colors.

End of Division 9

Current preferred product is Scuffmaster.

Sample painting should extend across a typical gypsum board wall joint to verify acceptability of substrate finish.

Division 10: Specialties

10.0 General

Custodial Planning Standards

The following applies to the design of spaces required for custodial

Verify space requirements with actual items of material and

Design & Construction Standards

services:

- Provide one central custodial room per building accessible from the service entrance or loading dock. Minimum size not less than 130 square feet.
- Provide built-in shelving as directed by Physical Plant. Generally all stored consumable materials must be stored off the floor.
- Door should swing out so as not to reduce the usable area of the closet
- Provide janitor closets for each 15,000 to 18,000 square feet of assignable building area, but not less than one per each floor, equipped with mop basin, fire-resistive, Fiber-Reinforced Plastic (FRP) wainscoting at basin location, shelf accessory with three mops or broom holders and hooks, clear floor space (minimum 3' x 5' to accommodate one wheeled service cart), one floor machine, and two stepladders.
- Provide 2 Ground-Fault Circuit Interrupters (GFCI) duplex outlets 24" Above Finished Floor (AFF) in accessible locations in each room.

equipment (stocked supplies, carts, floor machines, vacuum cleaners, ladders, etc.) that will be required to maintain specific facility and size custodial facilities as required.

Preferred janitor closet is similar to those in the first floor of the School of Nursing building.

Design & Construction Standards

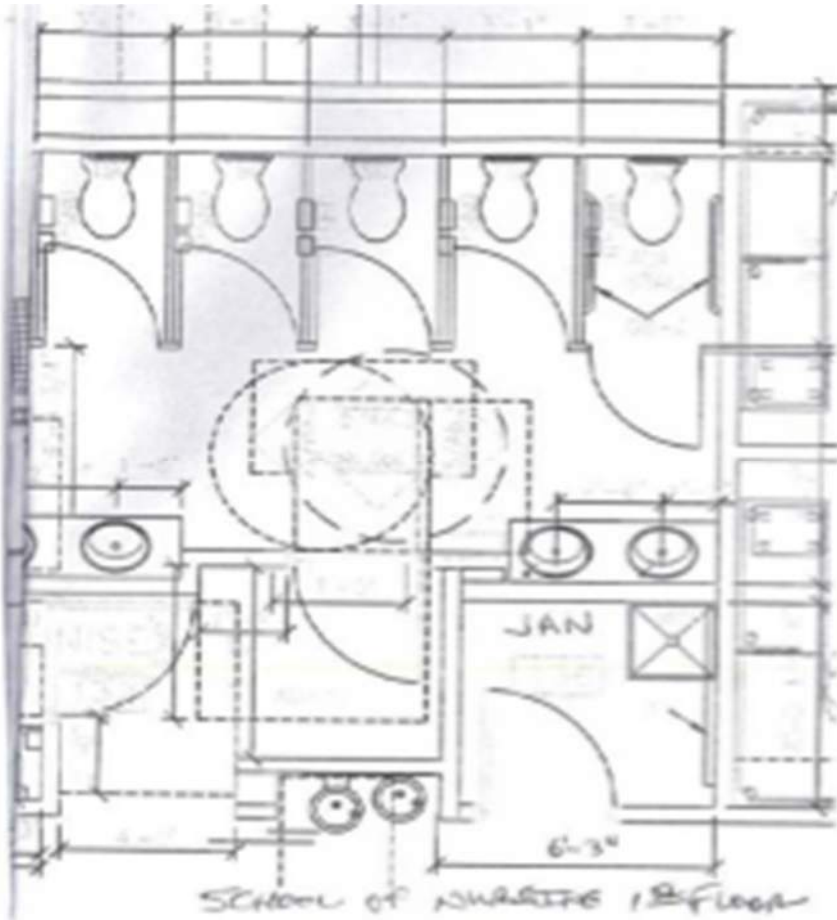

Physical Plant Storage

Coordinate with Physical Plant to provide adequate ventilated storage space for storage of building-specific items, including but not limited to attic stock materials, spare parts, lamps, seasonal maintenance equipment, equipment specific tools, and similar non-custodial items necessary for maintenance of the specific building.

Space and configuration for Physical Plant storage needs to be determined as applicable to the tenants and or function of space(s) in each building.

10.1 Signage

Interior signage shall be provided by contract or by Facilities Management personnel as directed by the Project Manager. The Project Manager shall provide the A/E, or the interior designer and or signage consultant, the established VCU interior signage standards. Signage criteria vary depending on location, such as Monroe Park Campus, MCV campus, etc.

Design & Construction Standards

10.2 Toilet Partitions and Stalls

Partition elements shall be comprised of scratch and corrosion resistive material like stainless steel or phenolic. Painted metal is not acceptable. Top secured only / hung systems are not acceptable. Continuous bracketing for wall mounting is preferred. Hardware elements shall be stainless steel. Exposed fasteners shall be tamper proof. Pilasters shall have shoes and sleeves (caps) to conceal anchorage assemblies. Partition or stall elements shall not impede or trap drainage to floor drains. Partitions shall be gap free, the maximum height possible while allowing for air circulation and shall have the minimum gap on the bottom that is allowed by code.

10.3 Toilet Accessories

See below for toilet room accessory and dispenser specifications.

For accessories not indicated (i.e. grab bars, shower seats, etc.) specify standard, readily available, heavy-duty commercial units. Select manufacturer's "quick-ship" products when appropriate so that replacement units can be more readily obtained.

- Toilet accessories to be contractor furnished and contractor installed.
- No battery operated paper towel dispensers
- Require a paper towel dispenser at every sink in labs



Note: *The specifications differ between campuses.*

Avoid custom units. Verify selections with VCU project manager.



Design & Construction Standards

Monroe Park Campus Toilet Accessories

 Georgia-Pacific Professional	Georgia-Pacific Professional 133 Peachtree NE Atlanta, GA 30303 1-866-HELLO GP (435-5647) www.gppro.com																								
Cormatic® Mechanical Designer Series Roll Towel Dispenser High capacity, key-locking towel dispensing system solution provides an attractive, hygienic, hands-free, portion-control solution.	Product Details <table border="1"> <tr><td>Brand Owner</td><td>Georgia-Pacific</td></tr> <tr><td>Brand</td><td>Cormatic®</td></tr> <tr><td>MFG Item#</td><td>HDS2008</td></tr> <tr><td>Design</td><td>Black</td></tr> <tr><td>UP - UPC</td><td>036500303082</td></tr> <tr><td>Each Per Ship Unit</td><td>1 Each</td></tr> <tr><td>Items Per Each</td><td>0 Each</td></tr> <tr><td>Case Total</td><td>1 Each</td></tr> <tr><td>Dispenser (WxDxH)</td><td>13.800" x 9.200" x 13.600"</td></tr> <tr><td>UNSPSC</td><td>47131701</td></tr> <tr><td>LEED EB&OM</td><td>IO</td></tr> <tr><td>Buy Multiple</td><td>1 EA</td></tr> </table>	Brand Owner	Georgia-Pacific	Brand	Cormatic®	MFG Item#	HDS2008	Design	Black	UP - UPC	036500303082	Each Per Ship Unit	1 Each	Items Per Each	0 Each	Case Total	1 Each	Dispenser (WxDxH)	13.800" x 9.200" x 13.600"	UNSPSC	47131701	LEED EB&OM	IO	Buy Multiple	1 EA
Brand Owner	Georgia-Pacific																								
Brand	Cormatic®																								
MFG Item#	HDS2008																								
Design	Black																								
UP - UPC	036500303082																								
Each Per Ship Unit	1 Each																								
Items Per Each	0 Each																								
Case Total	1 Each																								
Dispenser (WxDxH)	13.800" x 9.200" x 13.600"																								
UNSPSC	47131701																								
LEED EB&OM	IO																								
Buy Multiple	1 EA																								
	Case Shipping Info <table border="1"> <tr><td>GTIN</td><td>10036500303089</td></tr> <tr><td>Case Gross Wgt</td><td>8.050 lbs</td></tr> <tr><td>Case Net Wgt</td><td>7.300 lbs</td></tr> <tr><td>Case Dimensions (LxWxH)</td><td>14.500" x 14.125" x 9.750"</td></tr> <tr><td>Case Volume</td><td>1.156 CFT</td></tr> </table>	GTIN	10036500303089	Case Gross Wgt	8.050 lbs	Case Net Wgt	7.300 lbs	Case Dimensions (LxWxH)	14.500" x 14.125" x 9.750"	Case Volume	1.156 CFT														
GTIN	10036500303089																								
Case Gross Wgt	8.050 lbs																								
Case Net Wgt	7.300 lbs																								
Case Dimensions (LxWxH)	14.500" x 14.125" x 9.750"																								
Case Volume	1.156 CFT																								
Item Description: High-capacity Cormatic® mechanical roll towel dispenser helps you control costs with style. Our completely hands-free roll towel dispensers feature no buttons, levers or cranks that can serve as germ reservoirs, which helps you meet higher public health standards, assist in pollution prevention and control your operating costs through waste and maintenance reduction. This self-locking dispenser is designed to discourage pilferage while making towel dispensing a breeze. Choose our Cormatic® dispenser for a cost-effective system solution that is suitable for any washroom. Only available via one time, lifetime, Lease Agreement with GP or authorized distributor.	Unit Shipping info <table border="1"> <tr><td>Tl-Chy/Layer</td><td>9</td></tr> <tr><td>High-Layers/Unit</td><td>5</td></tr> <tr><td>Unit Qty</td><td>45</td></tr> <tr><td>Unit Dimensions (LxWxH)</td><td>43.500" x 42.750" x 48.750"</td></tr> </table>	Tl-Chy/Layer	9	High-Layers/Unit	5	Unit Qty	45	Unit Dimensions (LxWxH)	43.500" x 42.750" x 48.750"																
Tl-Chy/Layer	9																								
High-Layers/Unit	5																								
Unit Qty	45																								
Unit Dimensions (LxWxH)	43.500" x 42.750" x 48.750"																								
Features & Benefits: <ul style="list-style-type: none"> » High capacity dispenser reduces maintenance intervals and reduces the risk of run out for tenant satisfaction » Attractive design coordinates with washroom to enhance facility image » Portion control mechanism reduces solid waste by 25-35 percent by limiting the amount of product dispensed each time to lower towel costs 	 0 36500 30308 2																								



Design & Construction Standards

Monroe Park Campus Toilet Accessories



Georgia-Pacific Professional

Georgia-Pacific Professional
 133 Peachtree NE Atlanta, GA 30303
 1-866-HELLO GP (435-5647) | www.gppro.com

Cormatic® Automated Designer Series Towel Dispenser

New automated Cormatic® system provides a hygienic solution, operational efficiencies, and enhances your facilities image.



Item Description:

The new Cormatic® automated towel dispenser delivers the image of the Designer Series with patented, automatic, one-at-a-time dispensing. Powered by four long-lasting standard D-cell batteries providing for easy and low maintenance requirements, just move your hand in front of the dispenser's sensor. The result: enhanced image and hygiene with reduced towel usage and maintenance. Only available via one time, lifetime, Lease Agreement with GP or authorized distributor.

Features & Benefits:

- » *Reliable, hygienic touch free dispensing reduces risk of cross-contamination*
- » *Operationally Efficient - Reduces usage and waste to help your bottom line and the environment*
- » *Adjustable settings allow you to customize towel length, sensor range, time delay and hang mode*
- » *Uses long-lasting, standard D-cell batteries or optional AC power kits for easy and low maintenance requirements*
- » *ADA compliant when mounted properly*
- » *Warranty Program - covers workmanship and parts; while normal wear and tear and vandalism are not covered*
- » *UL Listed*

Product Details

Brand Owner	Georgia-Pacific
Brand	Cormatic®
MFG Item#	ADS2008
Design	Black
UP - UPC	036500302948
Each Per Ship Unit	1 Each
Items Per Each	8 Each
Case Total	1 Each
Dispenser (WxDxH)	14.250" x 9.100" x 15.500"
UNSPSC	47131701
LEED EB&OM	IO
Buy Multiple	1 EA

Case Shipping Info

GTIN	10036500302945
Case Gross Wgt	16.400 lbs
Case Net Wgt	9.372 lbs
Case Dimensions (LxWxH)	15.775" x 12.175" x 19.825"
Case Volume	2.200 CFT

Unit Shipping Info

Ti-Qty/Layer	8
High-Layers/Unit	7
Unit Qty	42
Unit Dimensions (LxWxH)	47.336" x 39.650" x 85.230"



0 36500 30294 8



Design & Construction Standards

Monroe Park Campus Toilet Accessories



Georgia-Pacific Professional
133 Peachtree NE Atlanta, GA 30303
1-866-HELLO GP (435-5647) | www.gppro.com

Compact® Vertical Four Roll Coreless Tissue Dispenser

New vertical Compact Quad™ tissue dispenser with 50% increase in capacity over Compact High Capacity dispensers for continuous service and reduced risk of run-out.



Item Description:
Attractive Compact Quad™ four roll vertical coreless bathroom tissue dispensing system holds up to 6,000 2-ply or 12,000 1-ply sheets while maintaining your professional look. Rolls face forward to minimize tabbing and comes with a dependable roll advancing system for extended service and increased patron satisfaction.

Features & Benefits:

- Reduces maintenance costs with more capacity and less waste versus jumbo junior tissue rolls and dependable roll advancing system features provides users with continuous service
- Holds 6,000 2-ply or 12,000 1-ply sheets by utilizing four large diameter rolls. 50% more than Compact High Capacity.
- Delivers user satisfaction & ease of use through high-quality 2-ply or high capacity 1-ply and sturdy dispenser system conveys upscale fashionable look appropriate for any decor
- Reduces waste and free up valuable space (vs. standard bath tissue.) No wrappers, No cores, & fewer stub rolls to discard. Smaller cases is easier to handle and fits storage closets better.
- Optional mounting brackets provide for easy installation and cleaning.

Product Details

Brand Owner	Georgia-Pacific
Brand	Compact®
MFG Item#	56744
Design	Quad™ Translucent Smoke
UP - UPC	073310567440
Each Per Ship Unit	1 Each
Items Per Each	0 Each
Case Total	1 Each
Dispenser (WxDxH)	11.750" x 6.900" x 13.250"
UNSPSC	47131710
LEED EB&OM	00
Replace Item	56778
Buy Multiple	1 EA

Case Shipping Info

GTIN	10073310567447
Case Gross Wgt	4.620 lbs
Case Net Wgt	4.100 lbs
Case Dimensions	6.900" x 11.750" x 13.250"
Case Volume	0.715 CFT

Each Shipping Info:

Each Gross Weight	4.62 LBS
Each Net Wgt	4.1
Each Dimensions	6.900" x 11.750" x 13.250"
Each Volume	0.715 CFT

Unit Shipping Info

Tt-Qty/Layer	12
High-Layers/Unit	6
Unit Qty	72
Unit Dimensions (LxWxH)	47.500" x 41.625" x 45.000"



0 73310 56744 0



Design & Construction Standards

Monroe Park Campus Toilet Accessories

Compact® Side-By-Side Double Roll Bathroom Tissue Dispenser



Description:

Attractive Compact® side-by-side coreless bathroom tissue dispensing system provides up to six times the capacity of single standard 2-ply rolls while maintaining your professional look. This dispenser delivers up to 6,000 sheets of tissue for continuous service and increased patron satisfaction. Featuring a transfer paddle to prevent access to a new roll before the current roll is completely used up, this dispenser offers one of the most cost-effective solutions for high-capacity bath tissue dispensing. Translucent Smoke color makes this dispenser the perfect choice for coordinating with the innovative enMotion® automated touchless towel dispensers.

Features & Benefits:

- » Delivers 3000 sheets of 2-ply or 6000 sheets 1-ply tissue to improve customer satisfaction, maximize staff efficiency and control labor costs
- » Transfer paddle deters early access to new roll, reducing stub roll waste
- » Coreless roll in durable, locking dispenser prevents pilferage

Product Details

Brand Owner	Georgia-Pacific
Brand	Compact®
MFG Item#	56784
Design	Translucent Smoke
UP - UPC	073310567846
Each Per Ship Unit	8 Each
Items Per Each	0 Each
Case Total	8 Each
Dispenser (WxDxH)	10.120" x 6.750" x 7.120"
UNSPSC	47131706
LEED EB&OM	10
Replaces Item	53771/01, 53701, 53702, 53703, 53704
Buy Multiple	8 EA

Case Shipping Info

GTIN	10073310567843
Case Gross Wgt	16.930 lbs
Case Net Wgt	14.400 lbs
Case Dimensions	24.000" x 15.500" x 14.875"
Case Volume	3.200 CFT

Each Shipping Info:

Each Gross Weight	1.94 LBS
Each Net Wgt	1.8
Each Dimensions	7.625" x 7.188" x 11.750"
Each Volume	0.370 CFT

Unit Shipping Info

T-Qty/Layer	40
High-Layers/Unit	3
Unit Qty	120
Unit Dimensions (LxWxH)	48.000" x 39.500" x 44.630"



Design & Construction Standards

Monroe Park Campus Toilet Accessories

GOJO Professional Skin Care Supplier: Product Catalog

Page 1 of 1



GOJO.com Company Information Careers > Product Catalog Markets Press Room

Product Catalog

- > By Product Type
- > By Market
- > By Brand
- > **By Dispensing System**
- > Download MSDS
- > How to Buy

GOJO® FMX-12™ Dispenser



Holds a 1250 mL sealed refill in a remarkably small footprint. Great for locations where a smaller, more traditional dispenser is preferred. Delivers more than 1,700 uses per refill. Features skylight with an extra-large site window. ADA compliant, one hand push operation. Optional key lock included.

[click image for enlarged view]

SKU	Dispenser	Case Pack	Color	Accessories
5150-06	GOJO® FMX-12™ Dispenser	6	Dove Gray	Handwash Counter Refill Alert Wall Plate
5155-06	GOJO® FMX-12™ Dispenser	6	Black	Handwash Counter Refill Alert Wall Plate

Search by GOJO SKU

Enter SKU

Enter first 4 digits of GOJO SKU

Printable version

Dispenser Installation Instructions (85.2 KB)

Dispenser Loading Instructions (28.7 KB)

Available Refills

- GOJO® E1 Foam Handwash
- GOJO® E2 Foam Sanitizing Soap
- GOJO® Green Certified Foam Hand Cleaner
- GOJO® Light Foam Hair Conditioner
- GOJO® Luxury Foam Antibacterial Handwash
- GOJO® Luxury Foam Hair & Body Wash
- GOJO® Luxury Foam Handwash

Company Information | Careers | Product Catalog | Markets | Press Room | Contact Us
How to Buy | Driving Directions

©2003 GOJO Industries, Inc. All rights reserved. Privacy Policy | Linking Policy
PURELL is a trademark of Johnson & Johnson and is used under license

http://www.gojo.com/product/dispenser.asp?sys_cat_id=107&brand_id=1

5/74/2007



Design & Construction Standards

Monroe Park Campus Toilet Accessories

Sanitary Napkin Receptacle 11SS Wal Mount

Page 1 of 1



[HOME](#)

[PRODUCT INDEX](#)

[ABOUT US](#)

[CONTACT US](#)

11SS

Sanitary Napkin Wall Mount w/Drop Bottom

Specifications:

- Dimensions: 10"W x 11"H x 5"Dp
- Weight: 4 lbs.
- Finishes: #304 Stainless Steel
- Carton Pack: One per carton
- UPS: Can Ship UPS
- Constructed of heavy duty bonderized steel
- Made of 30% recycled steel and is 100% post consumer recyclable.



Unique Features & Benefits:

- All #304 stainless steel construction.
- Release catch at bottom permits waxed bag to drop directly into collection receptacle so personnel need not reach inside.
- Attaches securely to a stall or wall with included mounting hardware.
- 3 waxed bags shipped with receptacle.
- Lift knob on both sides so the receptacle can be mounted on either side of stall.

[Home](#) — [About Us](#) — [Product Index](#) — [Contact Us](#)
United Receptacle 2007

<http://www.unitedrecept.com/11ss.htm>

01/17/2010



Design & Construction Standards

Monroe Park Campus Toilet Accessories

FINALLY... A FAST HAND DRYER.

FAST! Dries Hands Completely in 10-15 Seconds

Excel's research team has developed the **XLERATOR®** with patented technology that delivers **three-times-faster** hand drying performance. Conventional hand dryers take from 30 to 45 seconds to get a user's hands totally dry, and very few of us are willing to wait that long. With the automatic sensor-activated **XLERATOR**, not only do your hands get dry in 10 to 15 seconds, but consumer test participants report that their hands also felt warm, soft and really dry.

Uses 80% Less Energy.

Not only does the **XLERATOR** dry hands in one third of the time required by conventional hand dryers, our hand drying system is designed to run on 15-amp service (making it great for older buildings). The combination of these two factors results in 80% less energy cost per use vs. conventional hand dryers.

GreenSpec® Approved and Qualifies for LEED® Credits.

 **XLERATOR** is the first hand dryer to be GreenSpec Listed because it meets a number of GreenSpec standards; conserves energy, has low maintenance requirements and reduces waste.

 **XLERATOR** helps your facility qualify for LEED (Leadership in Energy and Environmental Design) Credit EA Credit 1 - Optimize Energy Performance, now a mandatory credit for any LEED certified facility. **XLERATOR** also lowers a facility's Carbon Footprint. Ask to see our Life Cycle Assessment (LCA) Study Results.

95% Cost Savings vs. Paper Towels

Converting to the **XLERATOR** hand dryer will result in more than a 95% savings vs. paper towel costs. In addition to paper towels, the following costs are also eliminated: ordering, storing, replenishing, collecting and disposing of bacteria-laden paper towel waste. This results in a **Payback of Less Than One Year!**

Setting a New Standard

After seven years in the marketplace, the **XLERATOR** hand dryer has received numerous awards and designations, appeared in case study articles done by prestigious trade publications, and been featured on national television programs! Because of its proven performance and customer satisfaction, **XLERATOR** is being specified in many high-profile facilities and has become... **THE NEW INDUSTRY STANDARD!**



3 Times Faster!



XLERATOR® IS RECEIVING A LOT OF ATTENTION

Ask about our Promotional Video
As seen on CNN Headline News
hosted by Terry Bradshaw.

(Available on CD. Or view this and other videos on our web site.)

TELEVISION APPEARANCES

 Contract Holder #GS-027-00177

AWARDS

Best New Product - Technology (International Hotel, Motel and Restaurant Show)

Top Ten Green Product (Environmental Building News)

Award for Design Excellence (ADEXO (Design Journal ADXZ Platinum Award))

Citation of Excellence (Buildings Product Innovations Awards)

FEATURED ARTICLES

The Wall Street Journal
Today's Facility Manager
American School and University
Environmental Design and Construction



TIME TO THROW IN THE TOWEL.







Excel Dryer has been awarded a contract by the GSA (General Services Administration) which offers special pricing to all Federal Government Agencies.



Design & Construction Standards

Monroe Park Campus Toilet Accessories

XLERATOR® HAND DRYER SPECIFICATIONS

Model XL-BW
Surface-mounted, Automatic,
White Thermostat (BMC) Cover

Model XL-W
Surface-mounted, Automatic,
White Epoxy Painted Cover

Model XL-GR
Surface-mounted, Automatic,
Gyrlite Textured Painted Cover

Model XL-C
Surface-mounted, Automatic,
Chrome Plated Cover

Model XL-SB
Surface-mounted, Automatic,
Brushed Stainless Steel Cover

Model XL-SI*
Surface-mounted, Automatic,
Custom Special Image Cover

*With Exclusive digital image technology allows for the addition of Company, School or Team logos with any color, design or a "green message"

Suggested Mounting Heights From floor to Bottom of Dryer

Hand Dryers	
Mens	45" (114 cm)
Ladies	43" (109 cm)
Teenagers	41" (104 cm)
Sm. Children	35" (89 cm)
Handicapped	37" (94 cm)

Units are 1100 Watts and available as Specified in:

110/120V	12.5 Amp	60 Hz
208V	7.0 Amp	60 Hz
220/240	6.5 Amp	60 Hz
277V	5.5 Amp	60 Hz
220/240V	6.5 Amp	50 Hz

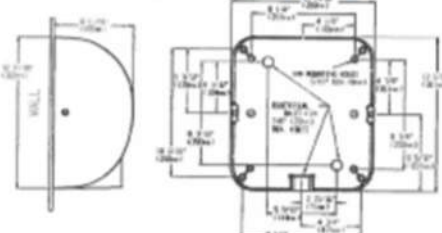

RECESS KIT - Meets ADA Protrusion Requirement of 4.1 inches (102 mm)

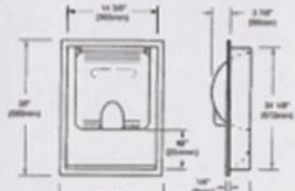
RECESS KIT (Optional)
Dimensions: 16 3/8" wide x 28" high x 3 3/8" deep
(416 mm wide x 680 mm high x 86 mm deep)
Weight: 11 lbs. (4.99 kgs.)

Note: Bottom of recessed wall box should be 1/8" (3.2 mm) below suggested mounting height for dryer base (shown).

XLERATOR® HAND DRYER CONSTRUCTION

A. Cover shall be one of the following: **Ble-cast zinc alloy** - One-piece, heavy-duty, rib-reinforced, lightweight, unbreakable, rustproof and all exposed surfaces shall be bright chrome plated or finished with chip-proof, electrostatically applied epoxy paint. **White Thermostat (BMC)** - Fiberglass re-reinforced bulk molding compound. **Stainless Steel** - with a brushed finish. **Special Image** - Digital image applied to cover using patented KolorFusion Sublimation Decoration process. All covers will be fastened to a wall plate by two chrome plated tamper-proof bolts.

B. Wall plate shall be equipped with (3) 7/8" (22 mm) diameter holes, one of which shall be suitable for use with surface conduit, for ease of wiring.

C. All internal parts shall be coated according to Underwriters' Laboratories, Inc. requirements.

D. Entire mechanism shall be internally grounded.

E. Optional RECESS KIT includes a wall box fabricated of 22 GA 18-8 type 304 stainless steel with 14 satin finish and a 16 GA 18-8 type 304 stainless steel dryer mounting plate. All welded construction. A stainless steel cable is connected to the dryer mounting plate to hold the dryer in position when servicing.

MECHANISM

A. Motor shall be a thermally protected, series commutated through-flow discharge vacuum motor/blower (5/8 HP / 20,000 RPM) which provides air velocity of 16,000 LFM (feet per minute) at the air outlet and 14,000 LFM at the hands (4 inches (102 mm) below air outlet).

B. Heating element is constructed of Nichrome wire and mounted inside the blower housing, thereby being vandal proof. It shall be protected by an automatic resetting thermostat, which shall open whenever air flow is cut off and shall close when flow of air is resumed. It shall produce an air temperature of up to 135°F (57°C) at a 72°F (22°C) ambient room temperature at the hands (4 inches (102 mm) below air outlet).

C. Control assembly is activated by an infrared optical sensor located next to the air outlet. The dryer shall operate as long as hands are under the air outlet. There is a 35-second lockout feature if hands are not removed.

LIMITED WARRANTY
The dryer shall be guaranteed to be free from defects for a period of five (5) years. Warranty shall include factory performed labor as well as the repair or exchange of defective parts, at manufacturer's option.

QUANTITY RECOMMENDATIONS
One dryer for every two washbasins is sufficient for most applications. If restroom traffic is unusually heavy, we suggest one dryer per washbasin in small installations and two dryers for every three washbasins in larger installations. When a 54" washbasin is used, we suggest four to five dryers.



See us in Sweet's
Printed on recycled paper
MADE IN THE U.S.A.



EXCEL DRYER Inc.
357 Chestnut Street • P.O. Box 365
East Longmeadow, MA 01028 U.S.A.
Tel: (413) 525-4531, Fax: (413) 525-2853
Email: sales@exceldryer.com
www.exceldryer.com

0909:0



Design & Construction Standards

Monroe Park Campus Toilet Accessories

Rubbermaid Commercial Products - Rubbermaid Waste : 3546 Untouchable® Round Co... Page 1 of 2



Waste > Indoor Utility

3546 Untouchable® Round Container



Available in round, half-round and square shapes to fit every application.

- Durable and crack resistant, even under tough indoor/outdoor conditions.
- Perfect for hotel lobbies, offices, restrooms, shopping malls, restaurants and other public locations.

AVAILABLE COLORS

Order #	Color	Product UPC/ UCC Code
FG354600 GRAY	GRAY	086876023480 / 10086876023487
FG354600 BEIG	BEIG	086876023459 / 10086876023456



Gray
GRAY



Beige
BEIG

SPECIFICATIONS

	U.S.	Metric
Length:		
Width:		
Height:	30 1/8 in	76.5 cm
Diameter:	15 3/4 in	40.0 cm
Square:		
Volume Capacity [Nom]:	22 gal	83.3 L
Volume Capacity [Max]:		
Volume Capacity [Min]:		
Carton Length:		
Carton Width:		
Carton Height:		
Carton Cube:	8.61 ft ³	0.24 m ³
Ship Weight/Carton:	27.60 lb	12.52 kg
Pack Quantity:		4
Cartons Per Pallet:		9
Material:	LLDPE	
Process:	Injection Molding	

ADDITIONAL INFORMATION:

Chemical Resistance Guide: chem.pdf

Products in Untouchable® Containers

Item #	Description	Length	Width	Height	Diameter	Square	Volume Capacity
2947	Untouchable® Round Container			18 3/4 in	15 3/4 in		44 3/8 qt
3520	Untouchable® Half Round Container	21 in	11 in	28 in			21 gal
3559-88	Untouchable® Square Container	16 1/2 in	15 1/2 in	30.9 in			23 gal
7920-20	Untouchable® Square Container with Swing Lid Combo	16 in	16.8 in	34.1 in			23 gal
3546	Untouchable® Round Container			30 1/8 in	15 3/4 in		22 gal
3958	Untouchable® Square Container	19 1/2 in	19 1/2 in	27 5/8 in		19 1/2 in	35 gal
3959	Untouchable® Square Container	19 1/2 in	19 1/2 in	34 1/4 in		19 1/2 in	50 gal

Accessories for 3546:

No.	Description
2672	Untouchable® Round Swing Top for 2947, 3546 Containers
3548	Untouchable® Round Funnel Top for 2947, 3546 Containers

<http://www.rcoworksmarter.com/rcp/products/detail.jsp?catalogCode=rcp&part&catCode=3546>



Design & Construction Standards

Monroe Park Campus Toilet Accessories

Rubbermaid Commercial Products - Rubbermaid Waste : 3548 Untouchable® Round Fun... Page 1 of 1



Waste > Indoor Utility

3548 Untouchable® Round Funnel Top for 2947, 3546 Containers

Hygienic tops for attractive, hands-free waste disposal.

- Funnel style lid for "no touch" refuse disposal.
- Controls waste, odors and smoking debris.



AVAILABLE COLORS

Order #	Color	Product UPC/ UCC Code
FG354800 GRAY	GRAY	086876023527 / 10086876023524



Gray
GRAY

SPECIFICATIONS

	U.S.	Metric
Length:		
Width:		
Height:		
Diameter:	16 1/4 in	41.3 cm
Square:		
Carton Length:		
Carton Width:		
Carton Height:		
Carton Cube:	1.33 B3	0.04 m3
Ship Weight/Carton:	5 1/2 lb	2.49 kg

Pack Quantity: 4
 Cartons Per Pallet: 48
 Material: HOPE
 Process: Injection Molding

ADDITIONAL INFORMATION:

Chemical Resistance Guide: chem.pdf

Products in Untouchable® Container Tops and Accessories

Item #	Description	Length	Width	Height	Diameter	Square
2654	Untouchable® Square Swing Top for 3558, 3559 Containers	20 1/8 in	20 1/8 in	6 1/4 in		20 1/8 in
2872	Untouchable® Round Swing Top for 2947, 3546 Containers				16 1/8 in	16 in
2859-88	Untouchable® Swing Top for 3559-07, 3559-88 Containers			4 in		
3548	Untouchable® Round Funnel Top for 2947, 3546 Containers				16 1/4 in	
3620	Untouchable® Half Round Lid, with Swing Door, for 3520, 3520-06 Containers	21 5/16 in	12 5/16 in	9 1/2 in		21.312 in

3548 is an Accessory to:

No.	Description	Diameter	Square	Length	Height	Volume Capacity	Width
2947	Untouchable® Round Container	15 3/4 in			18 3/4 in	44.3/6 qt	
3546	Untouchable® Round Container	15 3/4 in			30 1/8 in	22 gal	

Work Smarter.

Rubbermaid Commercial Products, LLC
 3124 Valley Avenue, Winchester, VA 22601
www.rcpworksmarter.com

<http://www.rcpworksmarter.com/rcp/products/detail.jsp?categoryCode=waste&subCategor...> 9/20/2010



Design & Construction Standards

MCV Campus Toilet Accessories

VCHS Campus
Toilet Accessories



ez HAND HYGIENE™
By KUTOL

Wall Mount Foam or Liquid Dispensing System



- ❖ **TOP DISPENSING**
Innovative design with push pad at top
- ❖ Can see soap being dispensed - **LESS WASTE, up to 20% savings of soap & water**
- ❖ **No-Leak Guarantee**
Conserves Resources
- ❖ **ADA Push Compliant**
- ❖ **Large View Window with Attractive Label**
- ❖ **Dove Gray or Black**
- ❖ **Proprietary System**

KUTOL
Hand Hygiene Specialists

7650 Camargo Rd. / Cincinnati, OH 45243
1-800-543-4641 / 513-527-5500
www.kutol.com



Design & Construction Standards

MCV Campus Toilet Accessories

Wausau Paper: Bay West: PRODUCTS

Page 1 of 1

Use Site

at Wausau Paper

BAY WEST

WAUSAUPAPER

ABOUT WAUSAU PAPER | **PRODUCTS** | MARKETS & USES | HOW TO BUY | REQUIREMENTS & IDEAS | NEWS & EVENTS

Products

- Overview
- Product Selector
- Comparison Guide

PRODUCT TYPES

- Roll Towels
- Folded Towels
- Bath Tissue
- Facial Tissue
- Household Paper Towels
- Industrial Wipers
- Dairy Towels
- Windshield Towels
- Seat Covers
- Soap

Dispensers

- Controlled Use
- Universal
- ADA Compliant
- HACCP

BUS BRANDS

Select a Brand

Dispensers

16000 Silhouette® Universal Roll Towel



Description

The Silhouette® universal roll towel dispenser accommodates most universal roll towels and provides at-a-glance maintenance. The push dispensing mechanism makes the dispenser easy to operate.

Features/Benefits

- Large capacity allows dispenser to go longer between refills
- Sturdy plastic construction to withstand years of commercial use
- Accommodates most universal roll towels

Specifications

Description	Universal Roll Towel Dispenser
Color	Black Translucent
Dispenser Size (W" x H" x D")	10 5/8 x 15 3/4 x 8 3/4
Dispenser Weight	6.7 lbs
Case Size (W" x H" x D")	18 1/8 x 10 15/16 x 10 1/4
Case Shipping Weight	8 lbs
Dispenser Case Cube	1.2
Cases Per Unit	72
UPC	0 85806 16000 4

[Home](#) | [Contact Us](#) | [Site Map](#) | [Corporate Site](#)

Wausau Paper is a trademark of Wausau Paper Corp.
© Copyright 2007 Wausau Paper Corp. All rights reserved.

<http://www.baywestpaper.com/products/productDetail.aspx?id=32>

7/24/2007

Design & Construction Standards

MCV Campus Toilet Accessories

San Jamar - Smart | Safe | Sanitary

Page 1 of 1



SAN JAMAR
Smart | Safe | Sanitary

Home | About Us | Distributor Locator | Careers | My Facilities | Contact Us | Support

Home | Warranty | Privacy Policy | Contact Us

What's NEW | Products | Trade Shows | Literature | Resources | Customer Care Center

Twin 9" JBT

Item Number	Capacity	Core Diameter	Dimensions (In)	Case Pack
R4000TSK	(2) 9" JBT rolls (230mm)	Min. 3.25" (83mm)	12" h x 19" w x 5.25" d	4
R4000TSL	(2) 9" JBT rolls (230mm)	Min. 3.25" (83mm)	12" h x 19" w x 5.25" d	4
R4090TSK	(2) 9" JBT rolls (230mm)	Min. 3.25" (83mm)	12" h x 19" w x 5.25" d	4
R4090TSL	(2) 9" JBT rolls (230mm)	Min. 3.25" (83mm)	12" h x 19" w x 5.25" d	4
R1090T/S	(2) 9" JBT	Min.	12" h x 19" w	4

Related Environments:  

Related Products:  

[Download CAD Drawing & PDF](#)

<https://www.san-jamar.com/Products/Detail.aspx?ProductID=1090>



Design & Construction Standards

MCV Campus Toilet Accessories

Sanitary Napkin Receptacle 11SS Wal Mount

Page 1 of 1



[HOME](#)

[PRODUCT INDEX](#)

[ABOUT US](#)

[CONTACT US](#)

11SS

Sanitary Napkin Wall Mount w/Drop Bottom

Specifications:

- Dimensions: 10"W x 11"H x 5"Dp
- Weight: 4 lbs.
- Finishes: #304 Stainless Steel
- Carton Pack: One per carton
- UPS: Can Ship UPS
- Constructed of heavy duty bonderized steel
- Made of 30% recycled steel and is 100% post consumer recyclable.



Unique Features & Benefits:

- All #304 stainless steel construction.
- Release catch at bottom permits waxed bag to drop directly into collection receptacle so personnel need not reach inside.
- Attaches securely to a stall or wall with included mounting hardware.
- 3 waxed bags shipped with receptacle.
- Lift knob on both sides so the receptacle can be mounted on either side of stall.

[Home](#) — [About Us](#) — [Product Index](#) — [Contact Us](#)
United Receptacle 2007

<http://www.unitedrecept.com/11ss.htm>

0/17/2010



Design & Construction Standards

MCV Campus Toilet Accessories

Rubbermaid Commercial Products - Rubbermaid Waste : 3546 Untouchable® Round Co... Page 1 of 2



Waste > Indoor Utility

3546 Untouchable® Round Container



Available in round, half-round and square shapes to fit every application.

- Durable and crack resistant, even under tough indoor/outdoor conditions.
- Perfect for hotel lobbies, offices, restrooms, shopping malls, restaurants and other public locations.

AVAILABLE COLORS

Order #	Color	Product UPC/ UCC Code
FG354600 GRAY	GRAY	096876023480 / 10086876023487
FG354600 BEIG	BEIG	096876023459 / 10086876023456



Gray
GRAY



Beige
BEIG

SPECIFICATIONS

	U.S.	Metric
Length:		
Width:		
Height:	30 1/8 in	76.5 cm
Diameter:	15 3/4 in	40.0 cm
Square:		
Volume Capacity (Nom):	22 gal	83.3 L
Volume Capacity (Max):		
Volume Capacity (Min):		
Carton Length:		
Carton Width:		
Carton Height:		
Carton Cube:	8.61 f3	0.24 m3
Ship Weight/Carton:	27.60 lb	12.52 kg
Pack Quantity:		4
Cartons Per Pallet:		9
Material:	LLDPE	
Process:	Injection Molding	

ADDITIONAL INFORMATION:

Chemical Resistance Guide: chem.pdf

Products in Untouchable® Containers

Item #	Description	Length	Width	Height	Diameter	Square	Volume Capacity
2947	Untouchable® Round Container			18 3/4 in	15 3/4 in		44 3/8 qt
3520	Untouchable® Half Round Container	21 in	11 in	28 in			21 gal
3569-48	Untouchable® Square Container	16 1/2 in	15 1/2 in	30.9 in			23 gal
7920-20	Untouchable® Square Container with Swing Lid Combo	16 in	16.8 in	34.1 in			23 gal
3545	Untouchable® Round Container			30 1/8 in	15 3/4 in		22 gal
3958	Untouchable® Square Container	19 1/2 in	19 1/2 in	27 5/8 in		19 1/2 in	35 gal
3959	Untouchable® Square Container	19 1/2 in	19 1/2 in	34 1/4 in		19 1/2 in	50 gal

Accessories for 3546:

No.	Description
2672	Untouchable® Round Swing Top for 2947, 3546 Containers
3548	Untouchable® Round Funnel Top for 2947, 3546 Containers

<http://www.rcoworksmarter.com/rcw/products/detail.jsp?catalogCode=waste&packCode=0000010>



Design & Construction Standards

MCV Campus Toilet Accessories

Rubbermaid Commercial Products - Rubbermaid Waste : 3548 Untouchable® Round Fun... Page 1 of 1



Waste > Indoor Utility

3548 Untouchable® Round Funnel Top for 2947, 3546 Containers

Hygienic tops for attractive, hands-free waste disposal.

- Funnel style lid for "no touch" refuse disposal.
- Controls waste, odors and smoking debris.



AVAILABLE COLORS

Order #	Color	Product UPC/ UCC Code
FG354800 GRAY	GRAY	066876023527 / 10066876023524



Gray
GRAY

SPECIFICATIONS

	U.S.	Metric
Length:		
Width:		
Height:		
Diameter:	16 1/4 in	41.3 cm
Square:		
Carton Length:		
Carton Width:		
Carton Height:		
Carton Cube:	1.33 cu	0.04 m3
Ship Weight/Carton:	5 1/2 lb	2.49 kg
Pack Quantity:		4
Cartons Per Pallet:		48
Material:	HDPE	
Process:	Injection Molding	

ADDITIONAL INFORMATION:

Chemical Resistance Guide: chem.pdf

Products in Untouchable® Container Tops and Accessories

Item #	Description	Length	Width	Height	Diameter	Square
2654	Untouchable® Square Swing Top for 3558, 3559 Containers	23 1/8 in	20 1/8 in	6 1/4 in		20 1/8 in
2672	Untouchable® Round Swing Top for 2947, 3546 Containers				16 1/8 in	
2680-08	Untouchable® Swing Top for 3569-07, 3569-81 Containers			4 in		16 in
3548	Untouchable® Round Funnel Top for 2947, 3546 Containers				16 1/4 in	
3620	Untouchable® Half Round Lid, with Swing Door, for 3520, 3520-06 Containers	21 5/16 in	12 5/16 in	9 1/2 in		21 3/16 in

3548 is an Accessory to:

No.	Description	Diameter	Square	Length	Height	Volume Capacity	Width
2947	Untouchable® Round Container	15 3/4 in			18 3/4 in	44 3/8 qt	
3546	Untouchable® Round Container	15 3/4 in			20 1/8 in	22 gal	

Work Smarter.

Rubbermaid Commercial Products, LLC
3124 Valley Avenue, Winchester, VA 22601
www.rcpworksmarter.com

<http://www.rcpworksmarter.com/rcp/products/detail.jsp?categoryCode=waste&subCategor...> 9/20/2010



Design & Construction Standards

MCV Campus Toilet Accessories

XLERATOR® HAND DRYER SPECIFICATIONS

Model XL-BW
Surface-mounted, Automatic, White Thermoseal (SMC) Cover

Model XL-W
Surface-mounted, Automatic, White Epoxy Powdered Cover

Model XL-GR
Surface-mounted, Automatic, Graphite Isolated Powdered Cover

Model XL-C
Surface-mounted, Automatic, Chrome Plated Cover

Model XL-SB
Surface-mounted, Automatic, Brushed Stainless Steel Cover

Model XL-SI
Surface-mounted, Automatic, Golden Copper Heavy Cover

*Note: Exclusive digital image technology allows for the addition of Company, School or Team logos with any color, design or a 'green message'

Suggested Mounting Heights from floor to Bottom of Dryer		Units are 1100 Watts and available as Specified in:	
Mens'	43" (109 cm)	110/120V	12.5 Amp 60 Hz
Ladies'	43" (109 cm)	208V	7.0 Amp 60 Hz
Teenagers'	41" (104 cm)	220/240	6.5 Amp 60 Hz
Sm. Children	35" (89 cm)	277V	5.5 Amp 60 Hz
Handicapped	37" (94 cm)	220/240V	6.5 Amp 50 Hz

RECESS KIT (Optional)

Dimensions: 16 3/8" wide x 26" high x 3 3/8" deep (416 mm wide x 660 mm high x 86 mm deep)
Weight: 11 lbs. (4.99 kgs.)

Note: Bottom of recessed wall box should be 18 1/2" (470 mm) below suggested mounting height for dryer (see above).

Dimensions: 11 3/4" lg. X 12 11/16" high x 6 11/16" deep
(298 mm lg. X 322 mm high x 170 mm deep)
Weight: XL-BW - 15 lbs. (6.80 kgs.) XL-SB 16 lbs. (7.26 kgs.)
XL-W, XL-GR, XL-C, XL-SI - 17 lbs. (7.71 kgs.)

MECHANISM

A. Motor shall be a thermally protected, semi-hermetic through-flow discharge vacuum motor/blower (5/8 HP / 20,000 RPM) which provides air velocity of 16,000 L/M (linear feet per minute) at the air outlet and 14,000 L/M at the hands (4 inches (102 mm) below air outlet).

B. Heating element is constructed of Nichrome wire and mounted inside the blower housing, thereby being vented proof. It shall be protected by an automatic resetting thermostat, which shall open whenever air flow is cut off and shall close when flow of air is resumed. It shall produce an air temperature of up to 135°F (57°C) at a 72°F (22°C) ambient room temperature at the hands (4 inches (102 mm) below air outlet).

C. Control assembly is actuated by an infrared optical sensor located next to the air outlet. The dryer shall operate as long as hands are under the air outlet. There is a 35-second lockout feature if hands are not removed.

LIMITED WARRANTY

The dryer shall be guaranteed to be free from defects for a period of five (5) years. Warranty shall include factory performed labor as well as the repair or exchange of defective parts, at manufacturer's option.

QUANTITY RECOMMENDATIONS

One dryer for every two washbasins is sufficient for most applications. If restroom traffic is unusually heavy, we suggest one dryer per washbasin in small installations and two dryers for every three washbasins in larger installations. When a 54" washbasin is used, we suggest four to five dryers.

See us in Sweet's
Printed on recycled paper
Printed in the U.S.A.

EXCEL DRYER Inc.
357 Chestnut Street • P.O. Box 365
East Longmeadow, MA 01028 U.S.A.
Tel: (413) 525-4531, Fax: (413) 525-2853
Email: sales@excelandryer.com
www.excelandryer.com

0909-0

Design & Construction Standards

Division 11: Equipment

11.0 General

All requests for audio visual equipment shall be coordinated with VCU Construction Management, Planning & Design, and Media Services.

All Information Technology requests shall be coordinated with VCU Construction Management, Planning & Design, Technology Services, and the General Contractor.

See "Division 27 Communications" sections for Media Support space planning requirements.

11.1 Fall Protection

All new construction and major renovation projects are required to comply with certain standards in Occupational Health and Safety Administration's (OSHA) General Industry Standard 1910 Subpart D - Walking-Working Surfaces. This applies to employees on a walking-working surface with an unprotected side or edge that is 4 feet or more above a lower level. The required standards include:

Note: The definition of a walking-working surface means any horizontal or vertical surface on or through which an employee walks, works, or gains access to a work area or workplace location

- Duty to have fall protection - 1910.28
- Design requirements for fixed ladders - 1910.23(d) - In addition to the standard requirements, all VCU fixed ladders greater than 10 feet in height shall have a ladder safety system or personal fall arrest system installed. Cages are no longer considered an acceptable means of fall protection {1910.28(b)(9)}. Ladder safety system designs must comply with 1910.29(i). Glideloc Vertical Height Access Ladder System Kits, see below.
- Design requirements for guardrail systems - 1910.29(b)
- Design requirements for skylights (holes) - 1910.29(e)
- General requirements for personal fall protection systems - 1910.140(c)

Additionally, all Fall Protection and Fall Arrest systems and components must meet the requirements found in the American National Standards Institute (ANSI) consensus standards: Z359-2007



I284
MFP9720153

Design & Construction Standards

11.4 Cold Rooms

Built in cold rooms to be on BAS and E-Power. For stand-alone units, consult with Engineering & Utilities on project specific requirements

11.5 Laboratory Equipment

Where research and teaching labs are required to have Emergency Eye / Face Wash and Emergency Showers, provide a recessed barrier-free swing-down eye / face wash with drain pan, and shower safety station with ceiling mounted exposed shower head combination unit.

Reference the preferred product by Guardian Equipment, model GBF2150, as an attachment in "Division 22 Plumbing" section.

Where research and teaching labs are required to have Emergency Eye / Face Wash only, provide a recessed barrier-free swing-down eye /face wash with drain pan unit.

Reference the preferred product, by Guardian Equipment, model GBF1735DP, as an attachment in "Division 22 Plumbing" section.

Where surface mounted Emergency Eyewash / Faucet combination units are required to supplement recessed swing-down emergency wash units, provide Faucet Eyewash Combo unit with the following features:

Reference the preferred product, by Speakman, model SEF-1800-CA-8, as an attachment in "Division 22 Plumbing" section.

- Combined gooseneck faucet with independently operated eye-wash
- Twin aerated eyewash sprays, with flip-top dust covers
- Eyewash activation by clearly delineated handle
- Faucet handles shall have at minimum 4" wrist blade handles for hot and cold water supplies, operating quarter-turn ceramic cartridges (25 year cartridge warranty).
- Eyewash faucet location shall be further identified

Design & Construction Standards

11.6 Lockers

Lockers are departmental equipment and are not maintained by Physical Plant. Locker design will vary based on the user's requirements. Below is a list of requirements for all lockers.

- Lockers shall be phenolic. Painted metal is not permitted.
- Lockers shall include an electrical outlet.
- Lockers shall include charging stations for portable electronics.
- Power for locker outlets and charging stations shall be on dedicated circuits.
- Lockers shall have electronic (digital) locking systems. Key based systems are not allowed unless specifically requested by the user.

End of Division 11

Design & Construction Standards

Division 12: Furnishings

12.0 General

All furniture will meet LEED standards or other accepted standards that are designed for sustainability.

VCU strives for 100% compliance in purchasing level-certified products.

The VCU Interior Designer or interior design consultant shall secure the following items, and turn them over to the Physical Plan Zone Leader upon occupancy:

- Cleaning and maintenance information provided on all products purchased.
- Furniture requiring operation shall be accompanied by operational standards.

All furnishings will meet respective fire and life safety codes, and proof of compliance is required.

Project costs will include removal and or disposal of any surplus items left in the space by the previous user.

Manufacturer warranties must be provided for all furnishings purchased, and related services provided. Warranties shall be for a minimum of 1 year.

12.9.3 Site Furnishings

The placement of bike racks will be coordinated through VCU Physical Plant Grounds, and will be placed in close proximity to off-site bike circulation paths and building entrances when applicable.

All exterior furnishings shall meet the requirements of the VCU Campus Amenity Guidelines

End of Division 12

Division 13: Special Construction

13.1 Lactation Rooms

In new construction and major renovations, a minimum of one

Design & Construction Standards

lactation room shall be provided.

Room shall be ADA accessible and include provisions for privacy, a sink, full length mirror and appropriate furnishings.

Refer to AIA Chapter 10.05 "Recommendations for designing lactation/wellness rooms.

End of Division 13

Design & Construction Standards

Division 14: Conveying Systems

14.2 Elevators

General Elevator Standards

- Comply with the following code requirements:
 - Virginia Construction Code
 - American Society of Mechanical Engineers – Safety Code for Elevators & Escalators (ASME A17.1)
 - Assuring Dependability in Architecture-based Adaptive Systems (ADAAS)
- VCU elevators tend to be very heavily used. Therefore, both public and freight elevators should be designed with durable, vandal resistant, low-maintenance finishes. Parts and components should be easy to replace in the event of damage.
- For buildings with color-coded floors, such as parking decks, the elevator call buttons shall be colored to match the color of the floor.
- All elevator shafts with glass shall be designed so that the glass can be cleaned safely and inexpensively.
- Fire service key shall be standardized. Coordinate with VCU Project Manager for key required.

Warranties & Service Contracts

All new elevators will have a 1 year service contract, with at least 4 possible annual extensions to include 24/7 response within 4 hours.

Operation & Maintenance (O&M) Manuals & Non-proprietary Equipment Requirements

- All elevator systems, including controllers, individual components, and software, shall be non-proprietary.
- Provide 4 sets of O&M manuals, to include operating features and diagnostic information, and all other necessary data for elevator system diagnosis, interpretation, and modification.

See CPSM for additional elevator specification requirements.

Requirements for non-proprietary components and systems are mandatory, to allow for service and maintenance by VCU personnel.

Design & Construction Standards

Include in each copy of the O&M manual “as-installed” straight line wiring diagrams, showing all electrical connections. Differentiate between factory-installed and field-installed wiring.

- Provide all proprietary diagnostic tools to VCU upon Substantial Completion, so that the elevators may be maintained by appropriately qualified VCU staff or other contracted elevator service providers. Provide all passwords and other necessary accessory items, so that individuals servicing the elevators can perform all adjustments on-site.
- Diagnostics, programming, adjustment tools, associated software, and information, must be non-expiring, fully functional, and usable throughout the life of the equipment. Upgrades and replacements for diagnostic tools, software, periodic update training, and other information, shall be provided to VCU at no additional cost on a perpetual basis for the life of the equipment installation.

Elevator Types

- Machine-room less elevators are acceptable.

Required Elevator Equipment

- Provide hall lanterns with floor position indicators at all elevator lobbies.
- Equip pits of hydraulic elevators with sumps for use of a portable sump pump during maintenance activities.

Final Acceptance

Require Contractor to provide a full Acceptance and Inspection Test in accordance with ASME/ANSI A17.1, conducted by a Qualified Elevator Inspector (QEI) as a condition of final acceptance by the Owner.

- VCU’s AHJ should accompany the QEI certified inspector during final testing.

Design & Construction Standards

End of Division 14

Division 18: Sustainability

18.0 General

The cumulative impact of the design, construction, and operation of built environments, has profound implications for human health, the environment, and the economy. VCU intends to minimize this impact, and will endeavor to create a positive impact whenever possible. A continuing focus on sustainable design of the built environment, will help VCU achieve its Sustainability goal for the year 2025 and 2050, per the VCU Climate Action Plan and VCU Quest for Distinction.

While sustainable building features may cost more initially than those found in a typical building, implementation of sustainable construction methods typically generates a pay-back in a rather short period of time, and will continue to generate cost savings over the life of the specific sustainable building element.

Costs, including projected energy and operational costs, must be evaluated as part of the design and value engineering project phases. Sustainable design elements that increase operational costs or generate significant or unusual maintenance activities, will require further justification and approval of VCU.

Implementation and application of these guidelines are intended to reflect compliance with Commonwealth of Virginia Executive Order No. 19: Conservation and Efficiency in the Operation of State Government:

<http://www.governor.virginia.gov/PolicyOffice/ExecutiveOrders/2010/EO-19.cfm>

18.1 Goal

Buildings

All new VCU buildings with exception to parking garages, shall be designed and constructed to obtain a minimum of LEED Silver certification or equivalent.

Equivalent programs may include the Virginia Energy Conservation and Environmental Standards, based in part on the International Green Construction Code (IgCC),

Design & Construction Standards

Parking Facilities

All new parking facilities shall implement the following sustainable features:

- Install photovoltaic solar panels on the top of parking decks, unless the sun is impeded and the top deck is shaded by nearby structures. Alternate green power generation technologies may be implemented. Aim to achieve at least net zero power consumption, and preferably assist in powering of nearby structures.
- Facilitate covered bicycle racks, and provide compressed air for bicycle tire inflation.
- Facilitate free premium covered parking for scooters and motorcycles, preferably near vehicle entrances and exits of parking facilities.
- Facilitate free electric vehicles parking. (Minimum Number and or Percentage of spaces).
- Install at least two Level 2, 30 Amp, electric vehicle battery charging stations per parking garage.
- Facilitate preferred parking for alternate fuel vehicles and hybrid vehicles.
- Facilitate free parking for Shared transportation vehicles.

18.2 Sustainable Purchasing Guidelines

VCU shall specify the use of environmentally preferable sustainable purchasing guidelines for new construction and renovation projects, to encourage the purchase and use of materials, products, and services that incorporate social, community, and environmental

and the Green Building Initiative's Green Globes program. Refer to CPSM 6.1.3.

Retrofitting of solar arrays to existing structures, requires engineering evaluation of existing structures to validate capacity to sustain additional gravity and wind loads.

Ideally, parking for scooters, motorcycles, and bicycles, will be located to minimize mixing these types of vehicles into the automobile and light truck traffic flow within the parking facility.

Note: *Preferential parking locations stated herein are subordinate to providing the required number of accessible parking spaces, including van-accessible spaces and providing accessible routes serving all such accessible parking spaces, as required by accessibility codes and the ADA Accessibility Guidelines.*

Design & Construction Standards

responsibility.

Electric Powered & Electronic Equipment

- Achieve sustainable purchases of at least 40% (by cost) of total purchases of electric-powered equipment including, office equipment (computers, monitors, printers, copiers, scanners, fax machines, etc.), appliances (refrigerators, dishwashers, microwave ovens, water coolers, etc.), external power adapters, televisions, and other audiovisual equipment.
- Energy Star-rated appliances and equipment must be purchased (or leased) when an Energy Star designation is available.
http://www.energystar.gov/index.cfm?c=products.pr_find_es_products.
- All new copiers, faxes, printers, and other such office equipment purchased or leased equipment, must be recycled paper compatible.

Furniture

Achieve sustainable purchases of at least 40% of total purchases of furniture by cost. Sustainable purchases are those that meet one or more of the following criteria:

- Purchases contain at least 10% postconsumer and or 20% postindustrial material.
- Purchases contain at least 70% material salvaged off-site or outside the organization.
- Purchases contain at least 70% material salvaged on-site, through organization's material and equipment reuse program.
- Purchases contain at least 50% rapidly renewable material.
- Purchases contain at least 50% Forest Stewardship Council

Design & Construction Standards

(FSC)

certified wood.

- Purchases contain at least 50% material harvested and processed, or extracted and processed within 500 miles of the project.

Mercury-Containing Lamps

Target for the overall average of mercury content in lamps of 90 pictograms per lumen-hour or less, which include lamps for both indoor and outdoor fixtures. At least 90% of installed lamps must comply with this target (as measured by the number of lamps).

Plumbing Fixture Guidelines

New buildings and future indoor plumbing renovations shall utilize the most current Uniform Plumbing Code (UPC) and International Plumbing Code (IPC) standards, or meet the latest EPA WaterSense Standards wherever possible for the particular application:

Fixture	UPC & IPC Standards	2011 EPA WaterSense Standards
Water Closet	1.6 GPF	1.28 GPF
Urinal	1.0 GPF	0.5 GPF
Public Lavatory Faucet	0.5 GPM	
Private Lavatory Faucet	2.2 GPM	1.5 GPM
Showerheads	2.5 GPM	2.0 GPM
Kitchen Sinks	2.20 GPM	
Metering Faucets	0.25 GPM	

(GPF - Gallons Per Flush)

(GPM - Gallons Per Minute)

Plumbing Best Practices

Design & Construction Standards

The following are types of recommended high-performance plumbing fixtures and fittings:

- Dual flush toilets which meet EPA WaterSense Standards, must be used and labeled as such.
- Use low-flow flush toilets approved by the EPA WaterSense Standards.
- All faucets must be approved by the EPA WaterSense Standards.
- Use faucet aerators.
- Use kitchen faucet spray aerators.

Paints & Sealants

- Paints and coating shall have VOC emissions not exceeding the VOC and chemical component limits of Green Seal's Standard GS-11 requirements.
- Adhesives, sealants, and sealant primers must comply with South Coast Air Quality Management District (SCAQMD) Rule 1168, based on VOC limits effective July 1, 2005, and rule amendment dated January 2, 2005.
- Preference is for brushed or rolled on paint procedures. Avoid spraying of paints and sealants whenever possible.

Painting and coating systems should be selected from products that can be maintained, repaired, and recoated using easily available low- VOC, low-odor materials.

Where spray-application of paints and coatings must be used, preferred use of High Pressure Low Volume (HPLV), or similar spray systems that minimize over-spray. Effective isolation and ventilation of work areas is required.

18.3 Solid Waste Management

Solid Waste Management Goals

- Protect the environment and public health
- Conserve natural resources
- Minimize land-filling and or incineration to reduce toxicity
- Reduce waste from facility alterations and new construction by at least 80% by weight.
- Reuse and or recycle demolition debris by at least 80%; maximize reuse of existing on-site material whenever possible.

Design & Construction Standards

18.4 Pest Management Plan

Refer to the VCU External and Internal Integrated Pest Management Plans for best practices during new construction. Inquire at Contract Administration for location of plans at (804) 828-1482.

18.5 Heat Island Reduction

Heat Island Reduction Goals

- Reduce “heat islands” created by building roofs to minimize impacts on microclimates, and human and wildlife habitats.

Roofs

- “White roofs” or vegetated roofs must be specified for all new construction projects.
- White roofs shall be used when replacing existing roofs.

Portions of roofs exposed to view in historic areas, or that are otherwise visible to the public are exempt from this “white roof” requirement. However, material selection must be taken into consideration for the reduction of the “heat island” effect through selection of appropriate materials and finishes.

External Walkways & Driveways

- Use alternate paving methods to minimize “heat island” effect.

18.6 Landscape

The following are the recommended landscape practices that help improve water quality, reduce storm water management loads, and relieve the demand on the locality storm water drain systems:

- Substitute permeable surfaces for traditional paving methods.
- Apply pervious material whenever practical for walkways and parking spaces.
- Use Xeriscaping and no lawn landscaping methods.
- Plant native and adapted plants.

Design & Construction Standards

- Use best practice methods for high efficiency watering, such as programmed drip systems and soil moisture content meters.

18.7 Water Harvesting

Water harvesting and sustainable erosion control practices should be applied to all new construction projects. Each newly constructed building shall implement at least two of the following strategies:

- Cistern strategies
- HVAC condensate water harvesting
- Grey water harvesting and reuse
- Bio-retention strategies
- Green screens, and living walls
- Rain gardens
- Bioswales

See also 13VAC5-63-320 Plumbing Systems and 9VAC25-740 Water Reclamation and Reuse Regulation, for regulations relative to rain water and gray water use and recycling strategies, in the USBC.

18.8 Sustainable Building Features

The following sustainable features should be incorporated during the planning and design phase of new building projects wherever feasible:

- Energy consumption indicators, such as Dash Board and Kiosks, should be placed near main entrance locations to attract the attention of the building users.
- L-2 Electric Vehicle battery chargers should be considered for feasibility according to area, and parking access to allow for battery charging.
- Covered Bicycle Racks, compressed air for inflating bicycle tires, dual chuck inflator valve, and scooter parking accommodations should be provided.
- Showers within 200 yards from the new building for men and women should be available to all faculty, staff, and students, to allow for showering and changing. If showers are not currently available, the new building shall facilitate showers as such.

Items listed are not inclusive of all potential sustainable building features. Identification of other sustainable building features, including alternative features to those listed during project programming is encouraged.

Regardless of any particular feature or set of features identified, all must be evaluated in relation to the specific project program, project budget, and operating budget.

Use of appropriate criteria listings, such as the United States Green Building Council (USGBC) LEED rating system scorecard, or

Design & Construction Standards

- Recycle bins should be placed at convenient locations in the building.
- Water Bottle Filling Stations should be implemented
<http://www.elkayusa.com/cps/rde/xchg/elkay/hs.xsl/ezh20.aspx>
- Electrical sub-metering should be included as part of the design; see EPA WaterSense for guidance.
- Water sub-metering should be included as part of the design.
- Specify the Purchase of WaterSense Labeled plumbing Products.
- Electrical Consumption: new buildings should be designed to consume the least possible power.
- New buildings shall meet or surpass the EPA Energy Star certification rating.
- Where the use of Light-Emitting Diode (LED) lamps are not feasible, high efficiency and low mercury lamps must be specified with the following criteria: 90 picograms per lumen-hour or less, which include all lamps for both indoor and outdoor fixtures.
- On-site Green Power Generation: every new building must have on-site sustainable power generation to reduce power demand on the power grid.
- Natural ventilation should be explored as potential partial substitute for mechanical cooling.
- All HVAC equipment must meet the highest industry efficiency standards.
- CO2 sensors should be installed in classrooms, large meeting rooms, and rooms designed for group gathering. These sensors should be integrated into the building airflow standard to ensure efficient ventilation.
- Use occupancy activated lighting.
- Solar Hot Water Heaters should be installed whenever the roof design permits.
- Consider installation of Tubular day lighting.

corresponding criteria sheets from Green Building Initiative (GBI) Green Globes, used to identify and document the overall sustainable design approach for a given project is encouraged.

Design & Construction Standards

- Use low-water use or waterless urinals.
- Use toilet dual flush valves.
- Use motion activated hand was faucets.
- Avoid using paper towel dispensers, prefer to use reusable roll towels wherever practical.
- All new buildings shall undergo Enhanced Commissioning, and Opposite Season Enhanced Commissioning programs.

18.10 Waste Receptacles

Indoor Waste Containers

The University has two standards for indoor waste containers:

- 20 gallon container for landfill
- 40 gallon container for recycling

Both indoor waste containers will have University's symbol for recycling on the top, and on the side. See indoor waste containers specifications on the next pages.



Design & Construction Standards

Indoor Waste Containers

Furniture Specifications



Date:
Revised:

Virginia Commonwealth University

Project Name:

Item: 20 Gallon Container for Landfill Items

Quantity:

Location:(keyed to plan)

Tag: M1A

<p>Manufacturer: Magnuson Group</p> <p>Style/Model No. VA1809L "Valuta"</p> <p>Description: 20 gallon steel unit with internal rigid liner and integrated bag arms, adjustable glides, 34 lbs. Lid: Open "Waste" Top for landfill items Icon: White "LANDFILL" icon, 3" wide, 4" high, to include "waste" pictogram and curved text above, as illustrated in inset below. Text to be single word, only, in English and all capital letters. Font to be Frutiger 65 Bold, 48 pt. Icon Location: On all 4 sides, in location shown below, centered side to side, 5.5" from top of container to top of curved text. Warranty: 2 Year</p> <p>Dimensions: 9" x 18", 33-3/4" high Opening: 4-1/4" x 13-3/16"</p> <p>Finish: Dark Anthracite body with Dark Anthracite top, baked on enamel</p> <p>Additional Information: Manufacturer Rep: Michael Toomey stmins@eol.com Cell: 202.674.4663</p> <p>Photograph/Line Drawing</p>	<p>This space reserved for equivalent offers (detailed specifications must be attached)</p> <p>Manufacturer:</p> <p>Style/Model No.:</p> <p>Description:</p> <p>Dimensions:</p> <p>Finish:</p> <p>Additional Information:</p> <p>Photograph/Line Drawing</p>
---	--





Landfill Icon

Note: Disregard illustrated icon on photograph

Note: Estimated cost for quantity of 1 is \$498.00. A set up charge of \$224.00 for custom icon design and development will be charged to the first order. Larger quantities may provide lower per item cost.



Design & Construction Standards

Indoor Waste Containers

Furniture Specifications		VCU <small>Virginia Commonwealth University</small>	Date: Revised:
Project Name:		Quantity:	Location:(keyed to plan)
Item: 20 Gallon Container for Recyclable Items			Tag: M1B
Manufacturer:	Magnuson Group	This space reserved for equivalent offers (detailed specifications must be attached)	
Style/Model No.	VA1809L "Valuta"	Manufacturer:	
Description:	20 gallon steel unit with internal rigid liner and integrated bag arms, adjustable glides, 34 lbs. Lid: Paper/Circle combo opening Icon: White "RECYCLING" icon, 3" wide, 4" high, to include "arrow" pictogram and curved text above, as illustrated in inset below. Text to be single word, only, in English and all capital letters. Font to be Frutiger 65 Bold, 48 pt. Icon Location: On all 4 sides, in location shown below, centered side to side, 5.5" from top of container to top of curved text. Warranty: 2 Year	Style/Model No.:	
Dimensions:	9" x 18", 33-3/4" High Opening: varies	Description:	
Finish:	Dark Anthracite body with Dark Anthracite top, baked on enamel	Dimensions:	
Additional Information:	Manufacturer Rep: Michael Toomey cfmnc@vcu.edu Cell: 202.674.4663	Additional Information:	
Photograph/ Line Drawing	 <p>Recycling Icon</p> <p>Note: Disregard illustrated icon on photograph</p>		

Note: Estimated cost for quantity of 1 is \$498.00. A set up charge of \$224.00 for custom icon design and development will be charged to the first order. Larger quantities may provide lower per item cost.



Design & Construction Standards

Indoor Waste Containers

Furniture Specifications		 <small>VIRGINIA COMMONWEALTH UNIVERSITY</small>	Date: Revised:
Project Name: Item: 40 Gallon Container for Landfill Items		Quantity:	Location:(keyed to plan) Tag: M2A
Manufacturer: Style/Model No.: Description: Dimensions: Finish: Additional Information: Photograph/Line Drawing:	Magnuson Group VA1818L "Valuta" 40 gallon steel unit with internal rigid liner and integrated bag arms, adjustable glides, 54 lbs. Lid: Open "Waste" Top for landfill items Icon: White "LANDFILL" icon, 3" wide, 4" high, to include "waste" pictogram and curved text above, as illustrated in inset below. Text to be single word, only, in English and all capital letters. Font to be Frutiger 65 Bold, 48 pt. Icon Location: On all 4 sides, in location shown below, centered side to side, 5.5" from top of container to top of curved text. Top Lid Labels: White "LANDFILL" labels on two opposite sides of top, centered side to side and facing outward. Font to be Frutiger 65 Bold, 48 pt. Warranty: 2 Year 18" x 18" square, 33-3/4" high Opening: 11-1/16" x 11-1/16" Dark Anthracite body with Dark Anthracite top, baked on enamel Manufacturer Rep: Michael Toomey ctmrc@aol.com Cell: 202.674.4663	This space reserved for equivalent offers (detailed specifications must be attached) Manufacturer: Style/Model No.: Description: Dimensions: Finish: Additional Information: Photograph/Line Drawing:	
  <p>Note: Disregard illustrated icon on photograph</p>			

Note: Estimated cost for quantity of 1 is \$636.00. A set up charge of \$224.00 for custom icon design and development will be charged to the first order. Larger quantities may provide lower per item cost.



Design & Construction Standards

Indoor Waste Containers

Furniture Specifications		VCU Virginia Commonwealth University	Date: Revised:
Project Name:		Quantity:	Location(s)(keyed to plan):
Item: 40 Gallon Container for Recyclable Items			Tag: M2B
Manufacturer:	Magnuson Group	This space reserved for equivalent offers (detailed specifications must be attached)	
Style/Model No.:	VA1818L "Valuta"	Manufacturer:	
Description:	40 gallon steel unit with internal rigid liner and integrated bag arms, adjustable glides, 54 lbs. Lid: Paper/Circle combo opening Icon: White "RECYCLING" icon, 3" wide, 4" high, to include "arrow" pictogram and curved text above, as illustrated in inset below. Text to be single word, only, in English and all capital letters. Font to be Frutiger 65 Bold, 48 pt. Icon Location: On all 4 sides, in location shown below, centered side to side, 5.5" from top of container to top of curved text. Top Lid Labels: White "RECYCLING" label on two opposite sides of top, centered side to side and facing outward. Font to be Frutiger 65 Bold, 48 pt. Warranty: 2 Year	Style/Model No.:	
Dimensions:	18" x 18" square, 33-3/4" high Opening: varies	Description:	
Finish:	Dark Anthracite body with Dark Anthracite top, baked on enamel	Dimensions:	
Additional information:	Manufacturer Rep: Michael Toomey cfmnc@raol.com Cell: 202.674.4663	Finish:	
Photograph/Line Drawing:		Additional information:	
  <p>Recycling Icon</p> <p>Note: Disregard illustrated icon shown on photograph</p>		Photograph/Line Drawing:	

Note: Estimated cost for quantity of 1 is \$636.00. A set up fee of \$224.00 for custom icon design and development will be charged to the first order. Larger quantities may provide lower per item cost.

Design & Construction Standards

Outdoor Waste Containers

The University's standard for outdoor waste containers is a square, black 59" W x 24" D x 45" H unit, with a larger section for recycling than

for landfill, to encourage recycling behavior. The outdoor waste containers are to have the "VCU Office of Sustainability" logo on three sides, and is made of recycled milk jugs.

See "VCU Office of Sustainability" logo below:



See photos of outdoor waste container below:

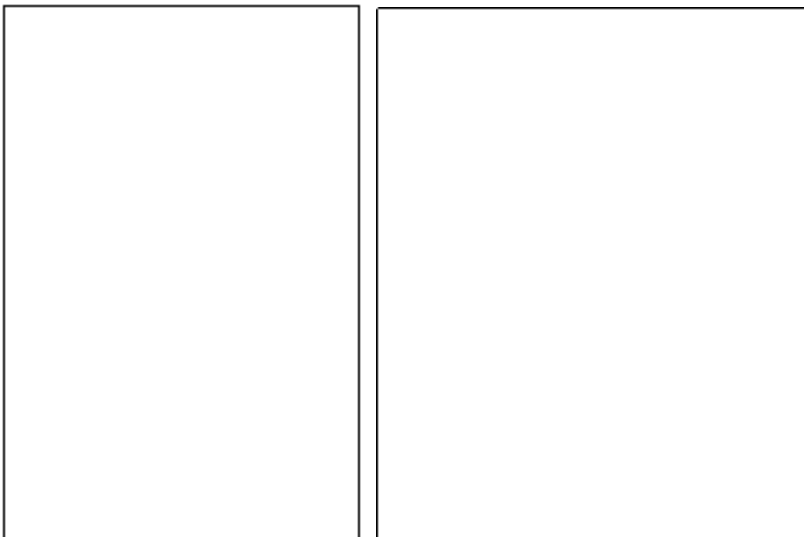



Design & Construction Standards

Elkay Specifications Cooler / Bottle Filling Station

ELKAY[®]

SPECIFICATIONS

EZH2O™ System

Cooler/Bottle Filling Station

Models EZS8WS and EZSTL(R)8WS

PRODUCT FEATURES

- Complete cooler and bottle filling station in a consolidated space saving ADA compliant design
- Sanitary, no-touch, sensor activation with automatic 20-second shut-off timer
- Flexi-Guard[®] or Vandal-Resistant StreamSaver™ Bubbler
- Silver Ion anti-microbial protection
- Quick fill rate is 1 gpm for refrigerated units and 1.5 gpm for non-refrigerated units
- Laminar flow provides minimal splash
- Real drain system eliminates standing water
- Visual user interface display includes:
 - Green Ticker™ counting the quantity of bottles saved from the landfill

IMAGES

Model EZS8WSLK shown. Includes Single Cooler with Bottle Filling Station.



Model EZSTL8WSLK shown. Includes Bi-Level Cooler with Bottle Filling Station.

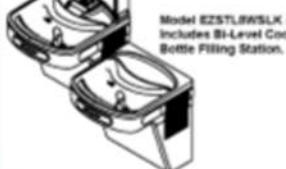

Unit shall provide 8.0 gph of 50° F water at 90° F ambient and 80° F inlet water. Bottle filling unit shall include an electronic sensor for no-touch activation with an automatic 20-second shut-off timer. Shall include bottle counter. Shall provide 1-1.5* gpm flow rate with laminar flow to minimize splashing. Shall include antimicrobial protected plastic components to prevent mold and mildew. Cooler shall include pushbar- activation and water-efficient StreamSaver™ bubbler. Bottle Filling unit shall meet ADA guidelines for parallel approach. Cooler shall meet ADA guidelines for frontal or parallel approach. Unit shall be lead-free design which meets Safe Drinking Water Act and is certified to NSF/ANSI 61 and California AB1953. Unit shall be certified to UL399 and CAN/CSA 22.2 No. 120.

OPTIONAL ACCESSORIES

- Vandal-resistant StreamSaver™ Bubbler
- 36292C Receptacle Adaptor Plug

SUGGESTED SPECIFICATION

APPLICATIONS

Ideal for use in:

- Educational facilities
- Healthcare facilities
- Sport and fitness centers
- Airports
- Office buildings
- Other commercial buildings

*Fill rate may vary slightly depending on existing waterline systems in the field

2222 Camden Court Phone: 630-572-3192
Oak Brook, IL 60052 Web: Elkayusa.com



Third Party Certified to:

- UL399 and CAN/CSA 22.2 No. 120
- Lead-free compliance including NSF/ANSI 61 and CA AB1953

In keeping with our policy of continuing product improvement, Elkay reserves the right to change specifications without notice. Please visit elkayusa.com for the most current version.

© 2011 Elkay
14-60 (4/2011)



Design & Construction Standards

ELKAY®

ROUGH-IN DIMENSIONS

*EZH2O is designed to fit on an EZ Cooler which is properly installed per the EZ Spec Sheet rough-in design.
Rated for Indoor Use Only

Single Cooler Installation

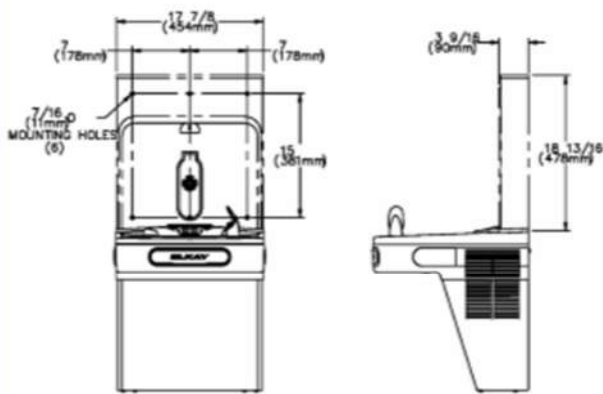

Bi-Level Cooler Installation

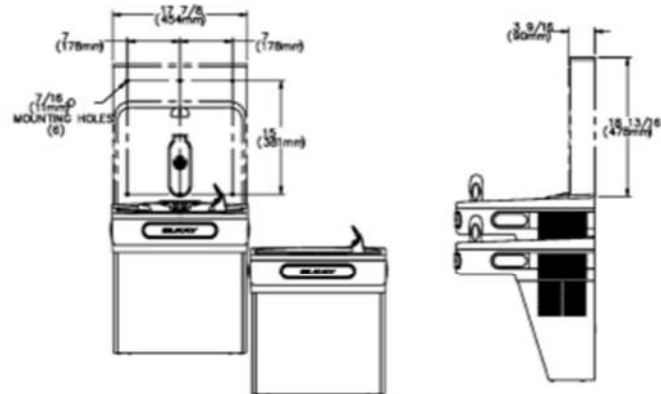

Installation Notes:

- Unit will mount on bracket attached to wall by 6 holes (as shown above)
- Water and electrical will connect through a hole punched into basin. Basin will be pre-punched.
- Refer to page 3 for EZ single cooler rough-in.
- Refer to page 4 for EZ bi-level cooler rough-in.

Job Name: _____

Date: _____ Qty: _____

Contact Info (Name, Phone, Email): _____

Approval for Manufacture Signature and Date: _____

Specifications and measurements are subject to change without notification. Please visit elkayusa.com for most current version.

2222 Camden Court
Oak Brook, IL 60523
Phone: 630-572-3192
Web: Elkayusa.com

**Model EZS8WS
and EZSTL8WS**



Design & Construction Standards

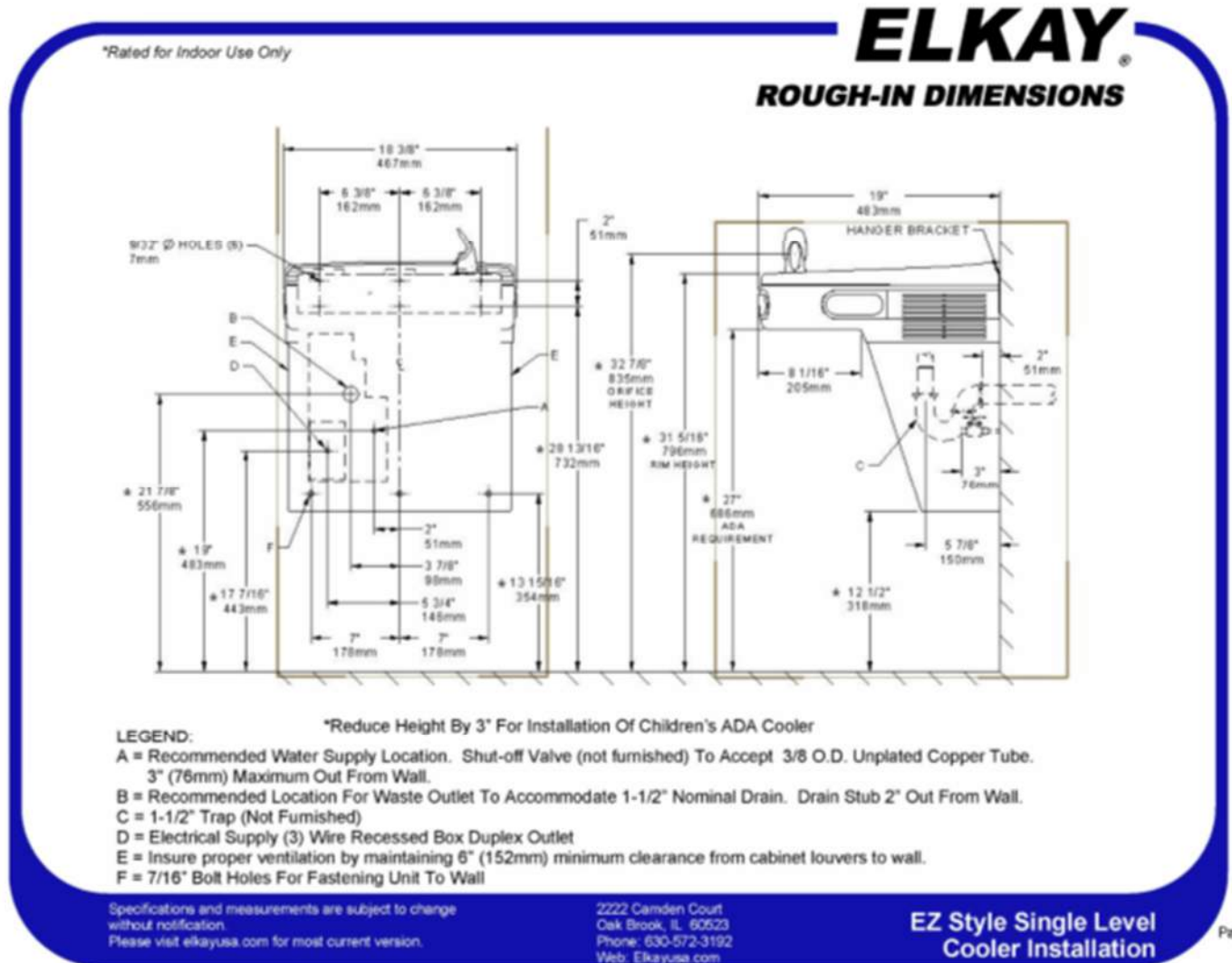

Design & Construction Standards

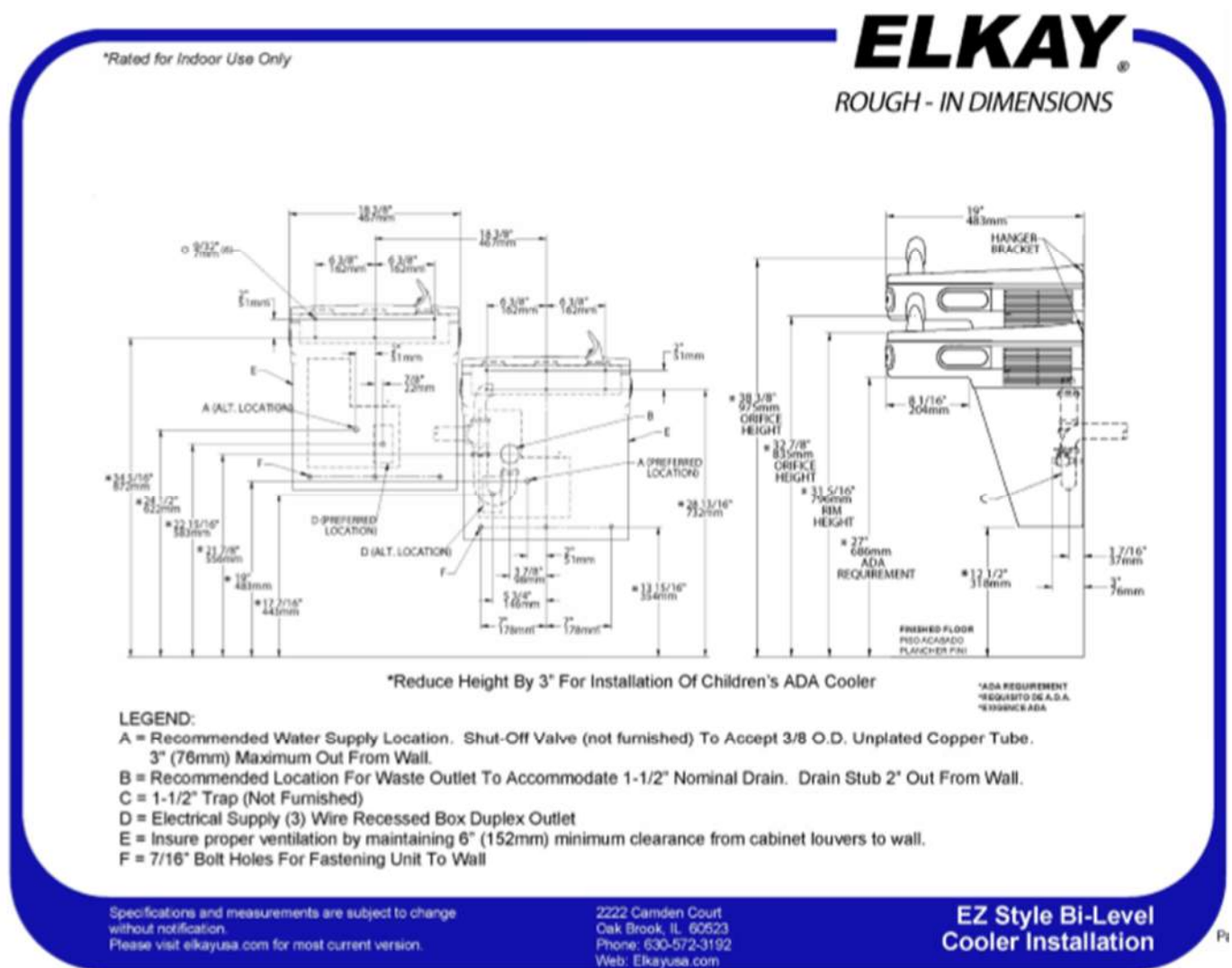

Division 21: Fire Suppression

21.0 General

Sprinkler Standards

Sprinkler systems must meet code minimums. Any design that goes beyond the code minimum, must be signed-off by VCU prior to approval.

- All control valves must be accessible by a 6' ladder.
- All control valves must be butterfly valves; no gate valves.
- All inspector's test drains must be the appropriate size, and

See "Division 28 Electronic Safety & Security" for fire alarm standards.

Design & Construction Standards

drain into an express drain.

- All sprinkler heads must be quick response sprinkler heads.
- Control valves shall only be installed in corridors, stairwells, mechanical rooms, fire pump rooms, sprinkler rooms, and shall be easily accessible.
- Inspector's test valves shall not be installed above or below ceilings in classrooms, offices, conference rooms, dormitory living quarters, or in any area requiring entry through a classroom, office, conference room, or any dormitory living quarters.
- Avoid pre-action systems when possible, especially in high rise buildings.

End of Division 21

Division 22: Plumbing

22.0 General

Refer to "Division 18 Sustainability" for fixture GPM requirements.

Pipe sleeves at floors should extend 2" above adjoining finished floor.

Natural gas (mass flow) meters are required for all boilers.

Accessible Restrooms

For new construction, provide one scooter accessible restroom stall with high impact finishes and a chair rail. If part of a larger restroom, provide one per gender. If for a single use restroom, one per building is sufficient.

Backflow Prevention

- Comply with requirements of the City of Richmond or other water supply authority requirements.
- Backflow assemblies shall meet the requirements of: United States Code (USC) American Society of Safety Engineers (ASSE) Std. 1013; American Water Works Association (AWWA) Std. C511; Canadian Standards Association (CSA) B64.4.

Design & Construction Standards

- A reduced pressure zone assembly shall be installed at each potential health hazard location, to prevent backflow due to back-siphonage and or backpressure.
- The assembly shall consist of an internal pressure differential relief valve, located in a zone between two positive seating check modules with captured springs and silicone seat discs.
- Seats and seat discs shall be replaceable in both check modules, and the relief valve.
- Valve body and check modules shall be brass.
- There shall be no threads or screws in the waterway exposed to line fluids.
- Service of all internal components shall be through a single access cover secured with stainless steel bolts.
- The assembly shall also include two resilient seated isolation valves, four resilient seated test cocks, and an air-gap drain fitting.
- Provide access for backflow preventers that are installed in obscure places, to allow removal of the entire unit for service and replacement.
- Floor drain pipe size to be determined and evaluated before installation of backflow preventer, to ensure that floor drain is capable of handling backflow to prevent flooding.

22.3 Non Metallic Pipe Tracer Wire

For all non-metallic underground piping (i.e. PVC) install tracer wire as follows:

- 12 gage, solid copper, blue jacket wire, zip tied to lines every ten feet. Ten foot coil in a valve box where run starts.

22.4 Plumbing Fixtures

Flush Valves & Toilets

- For all restrooms in new construction and major renovation projects, provide solenoid-actuator flush valves, actuated by electronic sensor for toilets (water saver) and urinals (low

Flush valves shall be on emergency power or have a mechanical override.

Design & Construction Standards

consumption). Battery powered units may be provided where installation of hardwiring is not feasible.

- VCU accepted manufacturers are Sloan, American Standard, and Toto, or approved equal.
- Standard toilets – wall mount elongated flush valves hard wired with manual override.
-

Faucets

- Provide solenoid-actuated touchless faucets. Faucets to be hardwired and on emergency power.

Floor Drains

Floor drain types to be generally as follows:

- Interior – Self priming
- Exterior/Freeze Area – Waterless

Confirm floor drain types with Physical Plant.

Water Cooler / Bottle Filling Station

For new construction and major renovation projects, provide one water cooler / bottle filling station on the first floor.

See “Division 18 Sustainability” to reference specifications for the preferred product, Elkay EZH20 Cooler / Bottle filling station, but may provide equivalent product.

22.4.5 Emergency Plumbing Systems

Where research and teaching labs are required to have Emergency Eye / Face Wash and Emergency Showers, provide a recessed barrier-free swing-down eye / face wash with drain pan, and shower safety station with ceiling mounted exposed shower head combination unit.

Reference the preferred product by Guardian Equipment, model GBF2150, as an attachment in “Division 22 Plumbing” section.

Where research and teaching labs are required to have Emergency Eye / Face Wash only, provide a recessed barrier-free swing-down eye /face wash with drain pan unit.

Reference the preferred product, by Guardian Equipment, model GBF1735DP, as an attachment in “Division 22 Plumbing” section.

Design & Construction Standards

Where surface mounted Emergency Eyewash / Faucet combination units are required to supplement recessed swing-down emergency wash units, provide Faucet Eyewash Combo unit with the following features:

- Combined gooseneck faucet with independently operated eye-wash
- Twin aerated eyewash sprays, with flip-top dust covers
- Eyewash activation by clearly delineated handle
- Faucet handles shall have at minimum 4" wrist blade handles for hot and cold water supplies, operating quarter-turn ceramic cartridges (25 year cartridge warranty).
- Eyewash faucet location shall be further identified by appropriate wall mounted or ceiling suspended signage.

Reference the preferred product, by Speakman, model SEF-1800-CA-8, as an attachment in "Division 22 Plumbing" section.

22.6 Compressed Air Systems

Air-cooled rotary screw compressors are preferred for system needs greater than 50 cfm.

Preferred manufacturers include Quincy, Ingersoll-Rand, LeROI, and Sullair.

Ascertain that proper ventilation is available for compressor location. Provide liquid-cooled compressors when ventilation is inadequate.

Compressed air systems shall have refrigerated driers.

The preferred manufacturer is Hankison.

Unless otherwise indicated, compressed air system shall be of "instrument" quality, as further modified by other requirements stated herein.

Uses requiring "Process" quality and medical air "breathing" quality air, require further development of project-specific criteria.

Compressed air system shall have redundant P3 filtration, followed by redundant coalescing air filtration.

Compressed air dew point shall be reduced to 40° F.

Existing pneumatic instrument air system in existing buildings shall be used while providing upgrades as needed.

Design & Construction Standards

Piping for compressed air systems shall be Type L copper.

Provide a certificate issued by an appointed examiner, or recognized inspection body in respect to the air receiver certifying the inspection during construction of the air receiver and its' auxiliary equipment.

22.67 Acid Neutralization Systems

Passive neutralization systems are preferable. Active systems can be used only with approval from VCU Safety & Risk Management and Engineering & Utilities.

- Connect to the BAS with 2 levels of alarms
- Spill containment must be provided

System shall be reviewed and approved by Safety & Risk Management and Engineering & Utilities.



Design & Construction Standards

Recessed Safety Station – Guardian GBF2150

GBF2150

Recessed Laboratory Units

- GBF2150** Recessed Safety Station with Drain Pan, Stainless Steel Shower Head
- GBF2150PCC** Recessed Safety Station with Drain Pan, Chrome Plated Brass Shower Head

Application: Recessed barrier-free eye/face wash and shower safety station with ceiling mounted exposed shower head and drain pan. Stainless steel cover provides attractive appearance and protects unit when not in use. When activated, cover serves as pan to collect waste water and return it into unit for drainage.

ADA Compliance: When installed at recommended mounting heights, unit complies with ADA requirements for accessibility by handicapped persons.

Shower Head: 10" diameter stainless steel (GBF2150) or 8" diameter chrome plated cast brass (GBF2150PCC).

Shower Valve: 1" IPS brass stay-open ball valve with stainless steel "panic bar" actuator.

Cover/Drain Pan: 18 gauge stainless steel combination cover and drain pan. Grasping "panic bar" handle and opening cover pulls spray head assembly down from vertical to horizontal position, activating water flow. While unit is in operation, waste water is collected in drain pan and returned into cabinet for drainage. Unit remains in operation until cover is returned to closed position.

Eye/Face Wash Spray Head Assembly: Two FS-Plus™ spray heads mounted on supply arms. Each spray head has individually adjustable flow control and filter to remove impurities from water.

Eye/Face Wash Valve: 1/2" IPS brass rotating plug-type valve. Furnished with Teflon® coated O-ring seals and in-line strainer to protect valve from debris and foreign matter.

Mounting: 18 gauge stainless steel cabinet with flanged rim for recessed mounting in wall. Unit fits in standard 3 5/8" deep wall.

Pipe and Fittings: Exposed pipe and escutcheon are brushed stainless steel (GBF2150) or polished chrome plated brass (GBF2150PCC).

Supply: 1" NPT female inlet.

Waste: 2" NPT female outlet.

Sign: Furnished with ANSI-compliant identification sign.

Quality Assurance: Unit is completely assembled and water tested prior to shipment.

U.S. Patent 5,768,721

Available Options:

- AP250-065 Modesty Curtain**
- AP280-230 Electric Light and Alarm Horn**
- TMV G3800** thermostatic mixing valve.



Note: Shown with optional AP280-230 electric light and alarm horn unit (sold separately).



GUARDIAN EQUIPMENT

660 North Union Street
Chicago, IL 60610
info@gesafety.com

Phone 312 733 2626
Fax 312 733 4684
gesafety.com



Design & Construction Standards

Recessed Safety Station – Guardian GBF2150

GBF2150 Recessed Laboratory Units

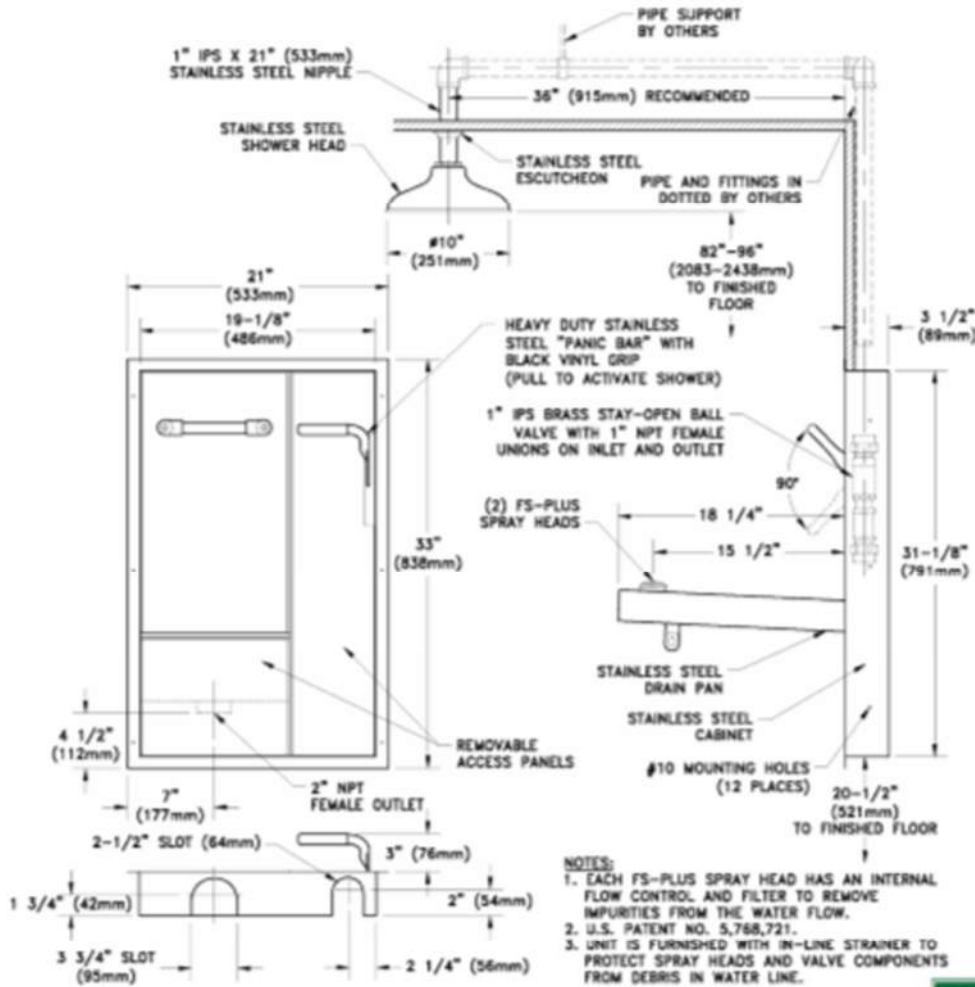

ETL Listed 101496
Units have been tested
to and comply with
ANSI Z358.1 - 2004



Sign included

This space for Architect/Engineer approval

GUARDIAN EQUIPMENT

600 North Union Street
Chicago, IL 60610
info@gesafety.com

Phone 312 733 2626
Fax 312 733 4684
gesafety.com

©2008 Due to continuing product improvement, the information contained in this document is subject to change without notice. All dimensions are ±0.01" (0.2mm).



Design & Construction Standards

Swing-Down Eye / Face Wash — Guardian Equipment GBF1735DP

GBF1735DP

Recessed Laboratory Units

- GBF1735DP** Swing-Down Eye/Face Wash with Drain Pan, Recessed Mounted
- GBF1736DP** Swing-Down Eye/Face Wash with Drain Pan, Surface Mounted

Application: Wall mounted barrier-free swing-down eye/face wash with drain pan. Stainless steel cover provides attractive appearance and protects unit when not in use. When activated, cover serves as pan to collect waste water and return it into unit for drainage.

ADA Compliance: When installed at recommended mounting height, unit complies with ADA requirements for accessibility by handicapped persons.

Spray Head Assembly: Two FS-Plus™ spray heads mounted on supply arms. Each spray head has individually adjustable flow control and filter to remove impurities from water.

Cover/Drain Pan: 18 gauge stainless steel combination cover and drain pan. Grasping "panic bar" handle and opening cover pulls spray head assembly down from vertical to horizontal position, activating water flow. While unit is in operation, waste water is collected in drain pan and returned into cabinet for drainage. Unit remains in operation until cover is returned to closed position.

Valve: 1/2" IPS brass rotating plug-type valve. Furnished with Teflon® coated O-ring seals and in-line strainer to protect valve and spray heads from debris and foreign matter.

Mounting: 18 gauge stainless steel cabinet. GBF1735DP cabinet has flanged rim for recessed mounting in wall. Unit fits in standard 3 5/8" deep wall. GBF1736DP cabinet is designed for mounting on wall surface.

Supply: 1/2" IPS female inlet.

Waste: 2" NPT female outlet.

Sign: ANSI-compliant identification sign.

Quality Assurance: Unit is completely assembled and water tested prior to shipment

Available Options:

- AP280-230 Electric Light and Alarm Horn** Flashing light/alarm horn unit is recess mounted in finished wall. Light is illuminated and horn sounds when shower is activated.
- TMV G3600** thermostatic mixing valve precisely blends hot and cold water to deliver warm (tepid) water as provided by ANSI Z358.1-2004.



ETL Listed 101496
Units have been tested
to and comply with
ANSI Z358.1 - 2004



GUARDIAN EQUIPMENT

600 North Union Street
Chicago, IL 60610
info@gesafety.com

Phone 312 733 2626
Fax 312 733 4684
gesafety.com



Design & Construction Standards

Swing-Down Eye / Face Wash — Guardian Equipment GBF1735DP

GBF1735DP Recessed Laboratory Units

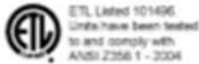
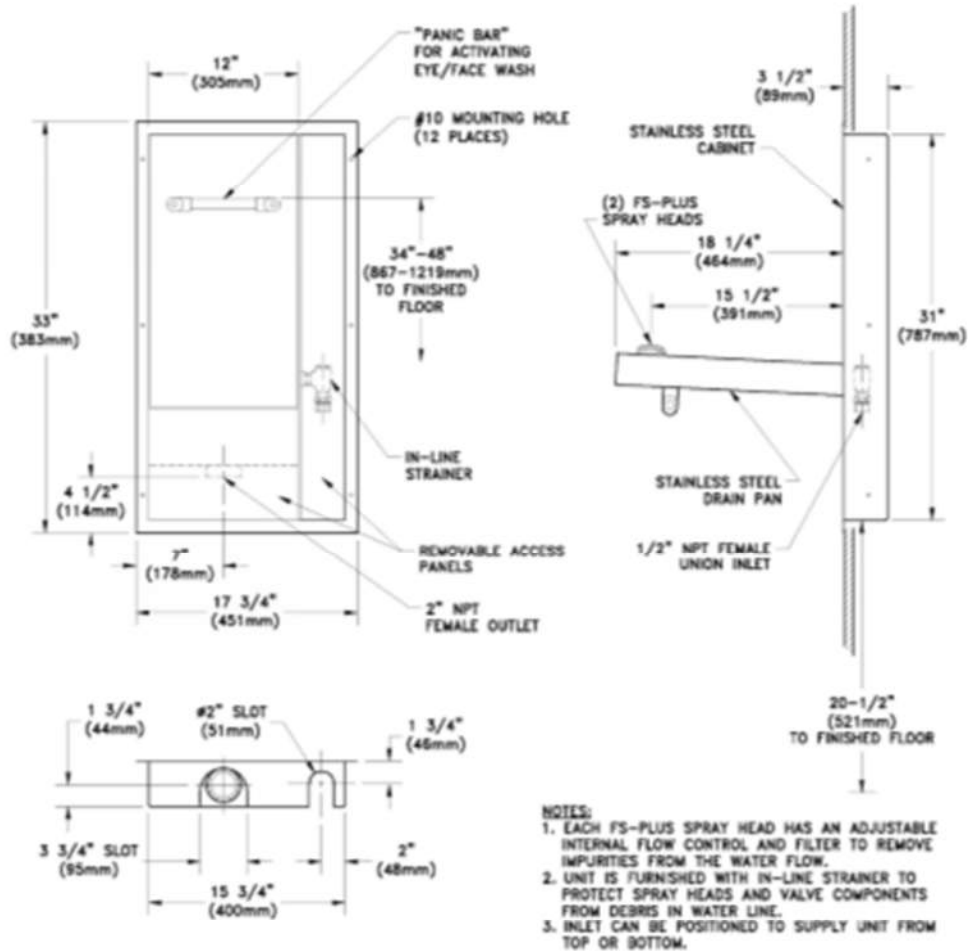

Sign Included

This space for Architect/Engineer approval

GUARDIAN EQUIPMENT

600 North Union Street
Chicago, IL 60610
info@gesafety.com

Phone 312 733 2626
Fax 312 733 4684
gesafety.com

10298 Due to continuing product improvement, the information contained in this document is subject to change without notice. All dimensions are x1/4" (5mm).



Design & Construction Standards

Eyesaver Faucet – Speakman SEF-1800-CA-8

SPEAKMAN® SEF-1800-CA-8

EYESAVER® FAUCET SPECIFICATIONS

DESCRIPTION

The SEF-1800-CA-8 Eyesaver® faucet combines a gooseneck faucet with an independently operated eyewash. The faucet features ¼ turn Speakman ceramic valves while the eyewash offers twin aerated sprays and flip-top dust covers. Lead free brass construction.

SPECIFICATIONS

EYEWASH

Activator: Pull handle with graphics
Spray heads: (2) aerated yellow plastic spray outlets with flip-top dust caps
Performance: 2.6 gpm @ 30 psi
Compliance: ANSI Z358.1

FAUCET

Supply: ½" male connections for hot and cold inlets
Widespread Valves: ¼ turn ceramic cartridges covered by a 25-year warranty
Center Distance: Adjustable center of 6" to 12"
Activator: Vandal resistant 4" wrist blades handles with color-coded indexes or single handle lever
Performance: 2.2 gpm
Counter thickness: Up to 2" thick
Compliance: ASME A112.18.1, CSA B125-98 and CA AB1953
Universal Emergency Sign Included

OPTIONS

- BO Vandal resistant 0.5 gpm flow control
- D75 Cross handles
- FP* Foot pedal activation
- LF Laminar flow outlet 2.2 gpm
- ST* Serrated tip with vacuum breaker
- TW Addition of SE-370 thermostatic mixing valve
- 6WH 6" wrist handles
- SL Two handle valves replaced with single lever valve
- NA Non aerated eyewash

* Not available in Lead Free option

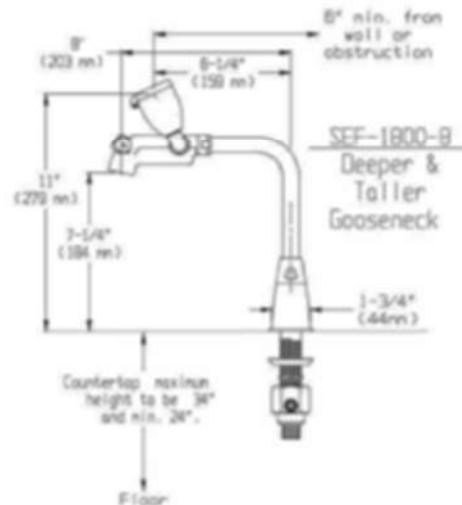

Job Name	_____
Location	_____
Architect/Engineer	_____
Sales Representative	_____
Wholesaler	_____
Date	_____
Model #	_____

400 Anchor Mill Road, New Castle, DE 19720 USA
1-800-537-2107 | Fax: 1-800-977-2747
WWW.SPEAKMANCOMPANY.COM

445

Revised Date
MAY 2011

Design & Construction Standards

Division 23: Heating, Ventilation & Air Conditioning (HVAC)

23.0 General

Temperature Tables

Mechanical systems shall be designed for the following set points:

- 75°F for cooling
- 70°F for heating.

General Heating Standards

- Central plant steam shall be used to the exclusion of all other sources where available.
- Humidifiers or autoclaves shall be used where central plant steam is not available, and total boiler horsepower installed, exceeds 40 bhp or where there is a single pass, 100% outside Air Handler Units (AHU).
- Steam coils with face and by-pass dampers shall be used. The use of hot water for pre-heats in air handler units shall be strictly prohibited.
- Hot water shall be the preferred medium, and shall be generated via a steam to water converter.
- The use of steam in direct radiation such as cast iron or fin coil radiators is not prohibited. The use of steam for heating coils in terminal equipment shall be prohibited.
- All freezestats shall be hard wired. Freezestats in the BAS programming logic shall not be acceptable.
- Steam Piping: All welded joints on exterior steam lines shall be radio-graphed by a third party for at least 25% of the welds. When a streamline is under a street and expected to be under a future building or otherwise inaccessible, then 100% of the welds shall be radio-graph tested. Due to the nature of the weld, socket welded pipes shall be tested using the dye penetrant method.
- For projects in existing buildings requiring modifications to

Design & Construction Standards

the HVAC system, the design engineer shall use a recent Test and Balance (TAB) report as the basis of design rather than using “As-Builts”, Record documents, design capacities shown on the faceplate of equipment, anecdotal information, or any other information as the basis of design. The TAB report shall be completed within 6 months of the start of the design.

- Enthalpy Wheels are not to be used for hazardous exhaust or wet lab space. Any use of an enthalpy wheel shall be approved by Engineering & Utilities and Risk Management

General Cooling Standards

- Air handler units shall have economizer cycles to allow the use of outside for cooling, when the exterior temperature is low enough.
- Where the load for the structure is 20 tons or less, air cooled Direct Expansion (DX) shall be used, provided that the lengths of refrigerant piping are short enough to ensure oil return.
- Where the load for the structure is greater than 20 tons consult with Engineering & Utilities as to whether an air cooled or water cooled chiller is appropriate. Water cooled chilled water systems shall be considered if space for cooling towers is available.

Exceptions

- For Vivarium or critical laboratory units, DX cooling shall be provided as a secondary back-up where chilled water is the primary source. In this case, the chilled water coil must be ahead of the DX Coil to prevent the chilled water coil from freezing.
- DX cooling shall not be used as the primary means of cooling for units over 5 tons, where the air handling units are 100% outside air (single pass).
- Chilled water shall be preferred over any other source of cooling from a central plant.

Design & Construction Standards

Mechanical Penthouse Rooftop Enclosures

The University wants to protect rooftop mechanical equipment from premature deteriorations caused by exposure from the elements, therefore, an enclosure is required. The enclosure need not be an extension of the building's architecture, what is traditionally called a "mechanical penthouse", but it needs to provide walls and a roof. The enclosure does not necessarily need to be fully enclosed, nor climate controlled. The size and construction of the enclosure should consider accessibility to the equipment, and the ease with which future equipment can be removed and replaced.

23.3 Motors & Variable Speed Drives

Electric Motors

Integral horse power electric motors shall have TEFC premium efficiency. ODP motors are not acceptable.

Variable Speed Drives (VSD)

Warranty period stating the dates and warranty service contract information shall be clearly labeled next to the VSD data plate.

Variable Speed Drive units shall have the following:

- Alpha-numeric and replaceable displays
- Non-proprietary fuses
- Integral bypass feature that lets motor operate if drive is inoperable
- Drives on all three contactor bypasses
- Fused input line with disconnect means in door
- Modbus / Lon Works communications interface
- Direct Current (DC) inductor filter or line reactors

23.5 Meters & Gauges for HVAC

Steam

All new buildings shall have meters installed where steam enters the building. The meters shall be owner furnished and contractor installed. The following diagram is for reference purposes only.



Design & Construction Standards

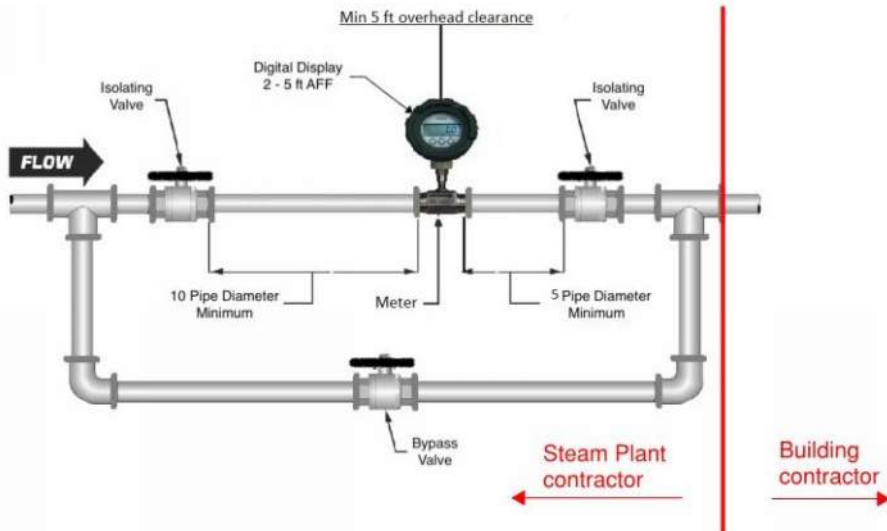

- VCU Steam Plant will supply, install, TAG, and commission the meter and its digital display
- VCU Steam Plant shall terminate all wiring connections to the meter.
- Meter shall be mounted horizontally with the lowest part of the meter body at 1 to 5 feet above finished floor, with a minimum of 5 feet overhead clearance, and sufficient clearance to allow for future replacement.
- Steam meter shall be located on the high pressure side ahead of the PRV station.
- Meter shall be mounted with a minimum of 10 straight pipe diameters upstream and a minimum of 5 straight pipe diameters downstream, with no other pressure affecting devices or other set up throughout the flow conditioning straight pipe run.
- Meter shall have flanged mounting connections.
- Meter and its display shall be located at least 5 feet away from EMF causing equipment.
- A dedicated power supply 120 VAC J-Box shall be mounted on the nearest wall to the meter.
- Steam meter body insulation will be provided by VCU Steam Plant.

Design & Construction Standards

- A bypass steam pipe of the same diameter shall be installed with both end connections located outside of the flow conditioning straight pipe run, with two independent manual isolation valves, and one manual bypass valve.

Steam Condensate

All new buildings shall have steam condensate meters installed inside of the new building at the exit point of service. The following steam condensate flow meter guidelines apply. The following diagram is for reference purposes only.

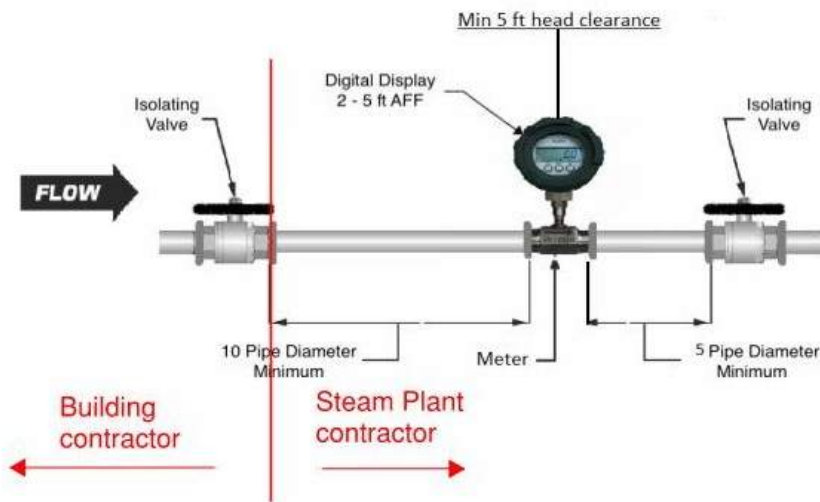

- VCU Steam Plant will supply, install, TAG, and commission the meter and its digital display.
- VCU Steam Plant shall terminate all wiring connections to the meter.
- Meter shall be mounted horizontally with the lowest part of the meter body at 1 to 5 feet above finished floor, with a minimum 5 feet overhead clearance.
- Meter shall be mounted with a minimum of 10 straight pipe diameters upstream and a minimum of 5 straight pipe diameters downstream, with no other pressure affecting devices or other set up throughout the flow conditioning straight pipe run.
- Condensate meter shall have flanged mounting connections.

Design & Construction Standards

- Meter and its display shall be located at least 5 feet away from EMF causing equipment.
- Meter shall be connected to the network, and shall be accessible thorough an IP address.
- A dedicated power supply 120 VAC J-Box shall be mounted on the nearest wall to the meter.
- A isolating valve and a strainer with manual blowdown valve shall be installed upstream of the flow meter, outside of the 10 D flow conditioning straight pipe run:
 - Strainers with manual blowdown valve shall be line size specific as follows:
 - Pipe size 2 to 3 inch: 33% open mesh area.
 - Pipe size 4 to 16 inch: 43% open mesh area.
- A check valve ad a ball valve shall be installed inside of the building downstream of the meter, but outside of the 5 D flow conditioning straight pipe run.
- Condensate piping shall be designed so that the stem condensate flow meter is flooded as all times.

Natural Gas

- The meter shall be mounted horizontally, and easily accessible for service and reading.
- The meter shall be supplied by emergency power where available. The electrical disconnecting means shall be lockable. A 120V to 24V DC power supply rated at 50 watts per meter. The meter output shall be transmitted to and readable over the BAS.
- Buildings with independent boilers shall have individual gas meters (mass flow) for each boiler, which shall transmit to and be readable over the BAS.

23.11 Facility Fuel Piping

Fuel oil piping for diesel-generators or boilers shall be carbon steel ASTM A106 Type S schedule 80. 2 1/2" or larger shall be welded.

Design & Construction Standards

Fittings for 2" threaded or less shall be Association of American Railroads (AAR) Malleable Iron Extra Heavy. 2 1/2" or larger shall use either ball valves conforming to API 607, or gate Valves conforming to API 605. 2" or smaller shall use ball valves conforming to API 607. Threaded joints shall use joint compound especially made for fuel oil service equal to "Gasoil".

23.20 HVAC Piping & Pumps

For any service, butterfly valves 4" and larger, shall be fitted with hand wheel gear operators. Butterfly valves in horizontal lines shall be installed with the stem horizontal.

Steam condensate piping 4" or smaller, shall not be less than seamless ASTM A106, A53 or API 5L schedule 80 in thickness. Threaded steam condensate lines shall use cast iron fittings. The use of malleable iron fittings is prohibited for steam condensate.

The use of non-rising stem valves for any service shall be prohibited. All threaded gate or globe valves shall have union bonnets. The use of threaded class 125 valves for any service shall be prohibited. The minimum acceptable rating for threaded valves shall be class 150.

The service entrance valve that is 2 1/2" or larger, isolating the building from the central district steam system, shall be flanged cast steel Outside Screw and Yoke (OS&Y) gate valve class 150 where the pressure is 150 psig or less, and class 300 where higher.

All condensate pumping packages shall be equipped with drains and discharge check valves.

For underground piping, 100% of the welds to be tested. Above ground the percentage of welds to be tested is to be determined on a case by case basis by VCU Engineering and Utilities. Discuss the testing protocol with the VCU project manager prior to preparing project specifications.

23.27 HVAC Insulation

Cellular Glass shall be used for chilled water lines 2" or larger. Chilled

Design & Construction Standards

water lines less than 2" may be insulated with Closed Cell Elastomeric. Use of fiberglass on chilled water lines shall be specifically prohibited. Chilled water coil condensate lines and domestic cold water lines shall be insulated with Closed Cell Elastomeric.

Steam lines (any pressure) shall be insulated with Calcium Silicate.

Insulation outdoors or otherwise exposed to weathering, shall be protected with metal jacketing.

Fiberglass pipe insulation is acceptable for heating hot water service.

23.28 HVAC Filters

Bag filters are preferred on air handling units. It is important that the same MERV rating be available. This should be evaluated at the design stage and discussed with VCU engineering & Utilities to get direction.

23.29 Ultraviolet C

A factory installed UV-C lighting system is required on all air handlers.

23.30 HVAC Air Distribution

Double wall insulated duct shall be used. The use of inside lined duct for any purpose shall be specifically prohibited.

Double wall insulated terminal boxes shall be preferred. Boxes used in humid environments like cage wash or autoclave rooms, shall be made of stainless steel inside and of epoxy or non-corrosive non-metallic exterior.

Terminal boxes shall have no exposed insulation inside.; a foil liner is not acceptable. Terminal boxes in laboratories and vivaria shall allow exterior sanitizing by wet chemical compounds, or alcohol solutions.

23.50 Meters

Steam Flow Meters

All new buildings shall have meters installed where steam enters the building. The following steam flow meter guidelines apply:

1. Meters shall be one of the below named products:

Design & Construction Standards

- ABB SR400 (Basis of design)
 - Onicon F-2600
 - Emerson Rosemount 8800
 - Spirax Sarco VLM10
2. Type: In-line Vortex or Swirl (Swirl preferred)
 3. Wetted material shall be stainless steel 316
 4. External pressure transmitter will supply flow sensor assembly downstream.
 5. Internal temperature compensation will be ordered with meter.
 6. Digital Communication output protocol shall be BACnet or FOUNDATION fieldbus. Highway Addressable Remote Transducer (HART) shall be used for device commissioning.
 7. Output shall communicate directly with the BAS with integrators.
 8. Meter output Liquid Crystal Display (LCD) display shall be mounted amount 5'-0" above finished floor, so it is readable from a standing position for most persons.
 9. Meter shall be factory calibrated to National Institute of Standards and Technology (NIST) traceable standards, and shipped with applicable documentation.
 10. All factory installation requirements must be followed without exception.
 11. Each meter shall have a flanged sensor connection design with unit completely insulated.
 12. Meters shall be suitable for 500° F superheated steam measurement process.

Chilled Water BTU (British Thermal Unit) Meters

All new buildings shall have meters installed. The following Chilled Water BTU Meter guidelines apply:

1. Meters shall be one of the below named products:
 - Onicon F-3100

Design & Construction Standards

- Approved equal (system 10 electromagnetic in-line flow meters, system with remote temperature detector)
- 2. Meter shall be factory calibrated to NIST traceable standards, and shipped with applicable documentation.
- 3. Digital Communication output protocol shall be BACnet or FOUNDATION fieldbus (HART for device commissioning).
- 4. Output shall communicate directly with the BAS with integrators.
- 5. Meter output LCD display shall be mounted amount 5'-0" above finished floor so it is readable from a standing position for most persons.
- 6. Meter accuracy shall be +/- 0.4% of reading from 3.3 to 33 ft/sec, +/- 0.8% of reading from 1 to 3.3 ft/sec and +/- 0.0075 ft/sec at flows less than 1 ft/sec.
- 7. Minimum installation clearance shall be no more than 3 pipe

23.57 Heat Exchangers

It is mandatory to use 316 stainless steel plate and frame heat exchangers.

23.65 Cooling Towers

Cooling towers shall be made of 316 stainless steel construction for the tower and basins, and provide meter on make-up water.

Acceptable meter manufacturers by the City of Richmond are the following:

- Sensus
- International
- Neptune Meter Company
- Hersey Meter Company
- Badger Meter Company

They shall provide access for safe, routine maintenance for the cooling towers. Cat walks should be provided around the entire perimeter if possible.

Design & Construction Standards

The impact of cooling tower fan noise on the surrounding area shall be considered in the selection of the fan and shroud. To minimize the noise impact on surrounding areas, a low noise type of fan and or fan shroud shall be specified when necessary.

The pipe and valve controlling the make-up of the cooling tower shall be sized by the engineer, and located at or within 5' of the cooling tower. Mechanical float type make-up control shall be preferred over electronic sensor types. This make-up to the cooling tower shall be in addition to hose bibs required for roof service. Cooling towers shall be selected using an 80° F wet bulb temperature. Towers using belt drives for their fans shall have provision for shielding the belt from the wet air stream.

Electric motors shall be of the TEFC or Totally Enclosed Air Over (TEAO) types. ODP motors are not acceptable. All disconnecting means and electrical control cabinets and enclosures related to the cooling tower and located outdoors, shall be of type by National Electrical Manufacturers Association (NEMA) 4X. All outdoor wiring related to the cooling tower shall be in either rigid conduit, or liquid tight flexible conduit. All cooling tower sumps shall be equipped with sump heaters to prevent freezing. Exterior condenser water lines shall be insulated and heat traced as well.

Cooling Tower Sub-Meters: Please utilize the link below to the City of Richmond's Department of Public Utilities website to direct designers to the design requirements:

http://www.richmondgov.com/dpu/documents/DPUForm_CoolingTowerSub-MeteringPermit.pdf

End of Division 23

Division 25: Building Automation System (BAS)

25.0 General

Uninterruptible Power Supply (UPS)

An Uninterruptible Power Supply is required for each Network Area

This is not a life / fire safety issue, or even a comfort issue

Design & Construction Standards

Controller with a minimum of 15 min. battery time. This UPS shall be powered by the building emergency power system with a dedicated circuit breaker.

since heating and cooling will be off in a power outage, but it is difficult, complex, and time consuming for Physical Plant to reset a controller in the event of a power outage.

Building Automation System

This standard applies to all new construction, all mechanical / electrical infrastructure renovation and replacement projects. For renovation projects, the VCU Project Manager shall evaluate the feasibility of system change-over on a case-by-case basis with Engineering and Utilities. These guidelines apply:

1. The following are the only acceptable manufacturers:
 - Johnson Controls (Metasys)
 - Automated Logic (WEBCTRL)
 - Siemens (Apogee)
2. All BAS networks will be BACnet/IP down to the field level devices such as terminal controllers. The network will use a star topology in which all IP devices are home run.
3. All materials shall be new, the best of their respective kind, and shall consist of the manufacturer's latest technology at the time of equipment submittal. All materials shall be undamaged.
4. The supplier shall provide laminated control drawings, including system controls schematics, sequences of operation, and panel termination drawings for major pieces of equipment. Terminal unit drawings shall be located in the central plan equipment panel, or mechanical room panel. The drawings shall accurately record the actual controller programming and settings at the time of occupancy for the building.
5. For spaces that house animals, the BAS shall monitor and record at a minimum temperature, humidity, lights (on/off),

In a letter dated December 7, 2017, Richard F. Sliwoski, VCU Associate Vice President for Facilities Management, authorized use of three acceptable suppliers (vendors named in Item 1) for new construction and major renovations.

Design & Construction Standards

and air pressure of space, to building reference point showing positive or negative.

6. All heat traces are to be set to alarm.

End of Division 25

Division 26: Electrical

26.0 General

Codes

Comply with requirements of the National Electrical Code (NEC), NFPA 70E, edition currently incorporated by reference into the VCC.

Basic Electrical Installation Requirements

- No shared neutrals
- No cut bushings
- All conduits 4" and larger shall be bushed
- Branch wiring, including neutral wires, shall be labeled on each end.
- Parking Decks are considered exterior applications.

Electric Motors

Integral horse power electric motors shall have TEFC premium efficiency. ODP motors are not acceptable.

Design & Construction Standards

26.1 Lightning Protection

Lighting protection shall be included in the design for all new buildings greater than 5,000 GSF in size in accordance with NFPA 780.

26.2 Outlet & Switch Labels

All electrical outlets are to be labeled with the panel and circuit numbers on the inside and outside of the cover plate. Junction boxes shall also be labeled with the same information

26.3 E Power Switches and Outlets

All outlets and switches which are connected to emergency backup power shall be red.

26.5 Conductors & Cables

Conductors except grounding wires shall be stranded.

Branch circuits shall be a minimum size of #12 AWG (American Wire Gauge), unless used for control wiring.

Conductors shall be copper, typical. Aluminum conductors are not acceptable.

All branch circuits shall have a separate equipment grounding conductor.

Raceways used in lieu of separate grounding conductors are not acceptable.

26.9 Instrumentation & Controls for Electrical Systems

Lighting shall be controlled by and integrated with the BAS.

Provide photocell circuit control for exterior lighting.

Provide occupancy sensor (motion sensor) control for classrooms and conference rooms, and similar shared space lighting.

Use of mechanical time clocks for lighting control is prohibited.

Fluorescent fixtures controlled by dimmer devices shall be burned in for a minimum of 100 hours at full capacity prior to being dimmed.

Communications Interfaces

Coordinate functions (points)

Design & Construction Standards

Provide Modbus / LonWorks communication interfaces for the following:

- Generators
- Transfer Switches

required to be monitored and or controlled with the VCU Project Manager and A/E.

26.20 Low-Voltage Electrical Transmission

- The preferred distribution voltage inside structures of 5000 square feet or larger shall be 480 / 277V Wye 3 phase.
- Where 120 / 208V 3 phase or 120 / 240V single phase is required, it shall be supplied by means of step down transformers.
- Installer shall properly torque all factory connections within panels, distribution panels, switchgear, and motor control centers.
- Multiple single pole breakers shall not be used for multiple pole applications.
- Engrave label attached with screws on each panel and disconnect shall be provided.
- Information on label shall include the electrical feed origin of the panel / disconnect.
- Distribution panels for lighting and power shall include a minimum of 30% spare capacity and spaces for future use.
- Electrical distribution panel covers shall be of hinged type for access.
- Service entrance switchboards shall have provision to attach an external generator of a size sufficient to power the entire building.

Wiring Devices

- Ground pigtails shall be used to ground devices to equipment grounding conductor.
- Devices shall not be used to continue circuit feed to other devices.
- Pigtails and joints shall be used to continue circuits to feed

Design & Construction Standards

other devices.

- All receptacles shall be rated 20 amp minimum, and shall be commercial specification grade in commercial applications.
- All receptacles shall be labeled with a panel number and a circuit number.
- All switches shall be rated 20 amp 120V / 277V, and shall be commercial specification grade in commercial applications.
- Enclosures for motor starters, control cabinets, or other device enclosures used where they may be subject to any overhead leaks, flooding, or infestation by vermin or wildlife, shall be a NEMA 4X enclosures at outdoor locations and NEMA 4 at indoor locations.

See picture below:



26.30 Facility Electrical Power Generation and Storing Equipment

Standby Generators

All new buildings shall have a standby generator with a fuel source approved by the VCU Project Manager. The following guidelines apply:

1. Emergency power systems shall have two sources of power.

Gas fired standby generators may be acceptable, but must be on uninterruptable service. Care should be taken to verify that the City has adequate capacity to feed new buildings. In one

Design & Construction Standards

- a. Normal
 - b. Standby back-up connected with an automatic transfer switch
2. The list of items to be connected to the standby generator includes, but are not limited to:
 - Fire alarm detection
 - Alarm systems
 - Emergency Egress and exit lighting
 - Public safety and voice communication systems
 - Fire pumps
 - At least one elevator
 3. If the building code requires other items to be connected, they shall be connected per Virginia Construction Code.
 4. Standby power must be available within 10 seconds of failure of the normal power supply.
 5. The standby power supply shall be available for operation of the rated loads for a minimum of 24 hours without refueling.
 6. The standby power generator shall have programmable logic controller mounted on the unit, and shall interface with the Building Automation System using BacNet protocol.
 7. Provide cam locking docking station per NEC 700.3F to allow for the connection of an external generator.

instance, the start-up of one of VCU's generators depleted gas feeds to nearby residential customers.

Diesel generators may be acceptable, but VCU's air permit limits the amount of exhaust we can generate. Therefore, low or no emissions diesel generators must be used.

Diesel Generators

Warranty period stating dates and warranty contact service information shall be clearly labeled next to generator data plate. Data plates should be engraved in metal and also:

- Shall be capable of power transfer within 10 seconds of power failure.
- Shall be tested at the factory and on-site, to ensure that all devices and auxiliary equipment work and that the automatic operation of the system is functional.
- The door to the room where the generator is located shall be labeled "Indoor Installations".

Shall be standby duty rated for the specified load including radiator fan and all parasitic loads. The generator should be sized to operate at the specified load at a max ambient of 77°F, and altitude of 500 feet.

A minimum warranty shall be five years from the date of acceptance by Owner against defective parts and or

Design & Construction Standards

- The training date and the startup date should be the same date.
- The generator should have a remote fill indicator for indoor installations 80%, and 90%.

workmanship, and shall provide parts and labor to fulfill this warranty at no cost to the Owner. Preventive maintenance shall be required the first year of the warranty period.

Diesel generator units shall be provided with the following:

- Modbus / LonWorks communications interface
- Battery powered 24V / 12V lighting in walk-in units
- Access platforms for units higher than 24" above finished floor
- Sound attenuated enclosures on all enclosed machines
- Spare filters included with each machine
- "Algae-X" type recirculating fuel filter systems on all units
- External load bank / tap 4X cabinets for all installs that can connect to a temporary remote generator set, or a load bank to test the existing installed generator set.
- Sight glass on radiator
- Common fault from the generator must go to fire alarm panel.
- Generators must have shunt trip breakers.
- Global reset for annunciator panel.
- Annunciator panel must be located adjacent to fire alarm panel, and must mimic the generator panel (example: if the generator panel is alarming the annunciator panel, it must also be in the alarm).
- If annunciator panel lights are present, they must be in operation when there is an option to be connected.
- Generator must have sufficient flow from front to back for cooling. All normal automatic transfer switch breakers must be located in main switch gear room.
- If the generator has louvered openings with control dampers for intake and exhaust, they must be fail open and powered

VCU uses a third party to monitor its' generators, and report to the appropriate responsible parties when generators must come online in actual emergencies. To facilitate this monitoring, the generators must have two sets of contacts and the automatic transfer switches must have a set of contacts dedicated to this cause. The two sets of contacts for the generator are for general fault status and run status. The set for the automatic transfer switches is to prove that it has transferred.

Design & Construction Standards

close.

- One spare set of fuel and air filters turnover.
- Pad lock latches must be on generators.

Provide sufficient on-site fuel capacity to operate diesel generators for a minimum of 24 hours at full rated load.

Transfer Switches

Provide units with the following features:

- Full control display pads (start, stop, test)
- Modbus / LonWorks communications interface
- Maintenance bypasses for automatic transfer switches are greater than 200 amps.

26.50 Lighting

Preferred voltage is 277V for lighting in structures larger than 5,000 ft².

Provide LED, fluorescent, or low mercury content lamps, typical.

Fluorescent lighting shall have a color temperature of 5000 K. Other colors may be used with approval when necessary.

Unless specifically required for a special purpose, do not use incandescent or halogen lamps.

Provide LED lighting for all exit signs.

Arrange and locate fixtures for easy accessibility for maintenance purposes.

All Exit Lights containing radioactive material (tritium) shall not be used on any VCU project.

End of Division 26

Design & Construction Standards

Division 27: Communications (Media Support)

27.1 General

Media Support Spaces

- Programming and Schematic design shall meet the requirements established through the Project Manager and VCUAIT (Virginia Commonwealth University Academic Information Technology). VCUAIT equipment rooms shall be dedicated for information technology, and telecommunications use (telephone, data, etc.).
- Be within 295 feet of cable run distance from the most remote site.
- Must have lockable doors.
- HVAC capacity to maintain ambient room temperature over the range 50 - 85°F, 30 - 75% relative humidity (non-condensing), positive pressure with air exchange sufficient to dissipate heat generated by equipment.
- Fire treated 3/4" plywood from floor to 8' - 0" above finished floor.

Media Support Standards

- All A/V conduit to be 1 ¼" EMT. Label as A/V conduit on drawings. Include pull strings in all A/V conduit.
- Label conduit or pull string with source and destination.
- For screen mounting use a double gang box, single gang box will not support 1 ¼" conduit.
- Drop down screens in new construction shall be by the general contractor. All controls shall have access panels.
- Contractor to include A/V install in the overall project schedule to avoid schedule compression at the end of projects.

VCU Media Support Services (MSS) to be included in page turn reviews.

A/E to coordinate with VCU Media Support Services on specifications and locations.

Design & Construction Standards

27.2 Data Communications

Network Closet Requirements

- One dedicated duplex NEMA 5-20R (for our UPS) in our MDF, IDF.
- Two NEMA 5-20R convenience (quad) outlets on a dedicated circuit on opposite walls.
- One wall covered with 4' x 8' x 3/4" fire rated plywood. Consult with VCU Network Services as to which wall.
- Conditioned air ducted into the space to maintain temperature and positive pressure. A dedicated system on emergency power is preferred.
- One 4" x 12" x 1/4" copper bus bar (min. #6 cu. AWG, green/bare, back to building steel) for grounding equipment, pre drilled/tapped with 1/4" holes (for two hole lugs) and mounted to the wall with standoff isolators.
- Code compliant lighting.
- Minimum of three 4" sleeves out of the closet wall (horizontal), firestop around outside of sleeve.
- Minimum of three 4" sleeves, floor-to-floor (riser), firestop around outside of sleeve.
- Lay in ceilings are not allowed in the closet.
- Floor tile is not required in closet. Sealed concrete is preferred. If tile is used, use non static tile.
- 3'-0" minimum wide door.
- Network closet shall be located as close as possible to the center of the floor and shall be accessible from the corridor.
- Network closets shall not be shared with other trades, crafts or facilities.
- Network closets shall be stacked floor to floor one over the other.
- Network closets shall be a minimum of 6'-0" x 8'-0".

Network closet standards are for new construction and major renovations. For renovation projects, consult with Network Services about the applicability of these requirements.

27.5 Distributed Communications & Monitoring Systems

Design & Construction Standards

Alertus Devices

- Provide Alertus Devices in all classrooms with 20 or more seats.
- Devices will be wall mounted at the front of the classroom area near the whiteboard, or other “front” location in the room.
- Devices require network and electric power connections. Network needs will be determined by Technology Services with Project Manager and coordinated with Physical Plant.
- Device must be installed with a “VCU Alert!” emergency sign.

Reference Alertus Alert Beacon Unit Installation Instructions document in “Division 27 Communications”.

ERTS Emergency Response Phones

ERTS phones are to be provided at parking areas and main entrances for each building. Each ERTS phone requires both electrical power and phone connections. These requirements should be planned as part of the project to avoid surface mounted conduit.

Confirm type of phone connection, Voice over Internet Protocol (VoIP) or analog, required for installation location.

Alertus Alert Beacon Unit Installation Instructions



Design & Construction Standards



Alertus Alert Beacon Unit Installation

Installation Overview

- 1) Determine desired mounting location
- 2) Determine power source
- 3) If necessary, install electrical box / wire mold to supply power to the Alert Beacon
- 4) Affix mounting bracket to the wall
- 5) Connect power / cables to the Alert Beacon
- 6) Set DIP switches, if applicable
- 7) Record the Unit ID and location description
- 8) Snap the unit into the mounting bracket
- 9) Test the unit



Figure 1: Installed Alert Beacon

This guide provides typical installation instructions. Please bear in mind that building codes vary and the technician installing the Alert Beacon units is responsible for compliance with any relevant codes.

General Mounting Guidelines

Recommended locations for installing Alert Beacon units include:

- 1) Heavily trafficked building corridors
- 2) Lobbies and points of egress
- 3) Administrative desks

For optimal coverage, each hallway and common area should contain at least one unit. Suggested mounting height is 48" above the floor, in accordance with accessibility recommendations.



Design & Construction Standards



Power Options

The Alert Beacon units can be powered by 12-24 Volts AC or DC, or by Power over Ethernet (PoE). The rear mounted, optional, NiMH rechargeable batteries serve as a back up in the event of a power outage. Note that due to the multitude of power options, Alertus does not include any power supplies with the Alert Beacons.

DC (not recommended for wall-mount installs): The most straightforward way to power an Alert Beacon is through the use of a plug-in DC power supply (commonly known as 'wall-warts'.) These supplies connect to the barrel plug on the back of the unit, as shown in Figure 2. This is most appropriate when the unit will not be mounted on a wall. DC output must be between 13.4V and 24V, with a capacity of at least 400mA. The barrel plug is 5.5mm x 2.5mm. Alertus recommends Digi-Key part #271-2574-ND.

DC power supplies are not suitable for all installations, however. They have a limited cable length, and the type of wire is not meant to be run inside walls. For mounted installations, an AC transformer is a better option.

AC transformer: Using an AC supply allows for a customizable cable length, and (when using plenum-rated cable) wiring can be run inside the wall. An AC transformer with an output between 13.4V and 24V is required. The installation details depend on the type of location.

Optional Backup Batteries: The Alert Beacon can use 6 standard 'AA' sized Nickel-Metal Hydride (NiMH) rechargeable batteries. Alertus recommends the use of batteries equivalent to Panasonic battery model HHR-210AAC4B. **IMPORTANT: DO NOT USE NON-RECHARGABLE BATTERIES** (i.e. alkaline batteries) as this may result in hazardous conditions, damage to the beacon hardware, and/or personal injury. Batteries are not provided by Alertus unless specifically ordered.



Figure 2: Alert Beacon with DC Power Adapter.



Design & Construction Standards



Alert Beacon Installation Instructions (v6.2)

Install location with a drop ceiling: the preferred method is to install an electrical outlet in the ceiling, and use a plug-in AC transformer (e.g. Mouser Part # 507-XT2420, or AllElectronics Part # ACTX-2420). This presents a number of advantages:

- Plug-in transformers include a locking screw to prevent accidental unplugging.
- Power can be disconnected without needing to turn off the mains; simplifies maintenance (i.e. if power supply needs to be replaced)
- The power supply for an external siren or strobe can be connected to the second outlet, providing for future expansion.

AC plug-in transformers do not come pre-wired, so it is necessary to obtain crimp-on spade lugs for the transformer connection, a compatible "Euro-block" style connector (Digi-Key Part # ED2779-ND or ED1701-ND) for the Alert Beacon connection, wire strippers and an appropriate crimp tool. See the section on "Connecting Power", below.

Install location without a drop ceiling: This typically requires a standalone step-down transformer. These are often slightly more expensive than the plug-in type, and are more complicated to install. However, this method is sometimes necessary if there is no place to install an outlet, or for aesthetic reasons. While a full install procedure for a hardwired transformer is beyond the scope of this document, the following are some UL-approved models known to function well with the Alertus Alert Beacons:

- Foster Transformer, Model 15343
- Grainger Item #6WU91 (fits inside a deep double-gang box)

The sample photos at the end of this document illustrate examples of installations using hardwired AC transformers.

Power-over-Ethernet: If the Alertus System is being deployed using Ethernet communications, a third option is to use Power-over-Ethernet (PoE). This minimizes the necessary wiring, but requires PoE-capable network switches (or in-line power injectors.) The Alert Beacon is a Class 0 PoE device; it typically draws approximately 10 watts of power.

See the Alertus Support page at http://support.alertustech.com/wiki/Power_Over_Ethernet for more info.



Design & Construction Standards



Mounting Options and Accessories

Select a suitable mounting option from the three options below. Installation examples of each mounting option are provided at the end of this manual.

Flush Mount Bracket

The low-profile flush mount bracket is included standard with every Alert Beacon. By itself, this bracket is suitable for mounting the unit on drywall, or anytime the power cables can be run inside the wall. It attaches directly to a double-gang electrical box using 2 to 4 #6-32 screws. Note that the box must be recessed into the wall; if this is not an option (i.e. on masonry walls) then the additional Surface Mount Adapter should also be used.

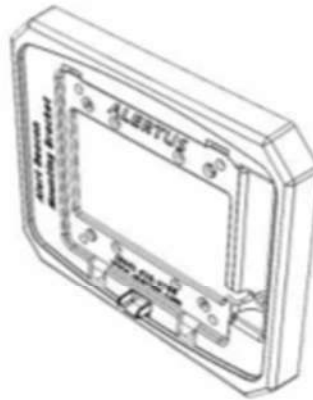

Surface Mount Adapter

If it is not feasible to recess the electrical box inside the wall, then a Surface Mount Adapter may be required. This extension combines with the standard Flush Mount Bracket to increase the total depth, allowing the Bracket to mount on a double-gang surface mount Wiremold box. The inner rim of the Surface Mount Adapter has punchouts on the top and bottom to allow cable entry via Wiremold conduit.

If you have received a Surface-Mount Adapter as part of a first article kit, **please note that while there is no additional charge for these parts, they are not included unless requested.** If you have determined that your installation will require Surface Mount Adapters, please make your sales representative aware of the quantity you would like to receive.



Design & Construction Standards



Alert Beacon Installation Instructions (v6.2)

Wire Desk Stand

The desk stand provides a simple and easy option for deploying Alert Beacons at administrative desks or in offices, as well as in temporary locations. Other stand options are also available; contact Alertus for details.



Optional Accessory: Wire Guard

To protect against theft, vandalism, or accidental damage (in locations such as a gymnasium) Alertus offers a wire guard cage as an optional accessory.



Mounting the Bracket

The procedure for attaching the bracket depends on the bracket type.

Flush Mount Bracket

The low-profile, "Flush Mount" bracket is designed to mount to a standard double-gang electrical box. The box should be installed as normal, i.e. recessed into the wall so that the mounting tabs are flush with the wall surface. All required wiring should be run into the box before proceeding.

Once the box is securely mounted to the wall, attach the flush mount bracket using 2 to 4 #6-32 screws (1 1/2" length suggested.) The inner-most holes on the bracket should line up with the appropriate holes on the double-gang box. Figure 3 shows an installed Flush Mount bracket.

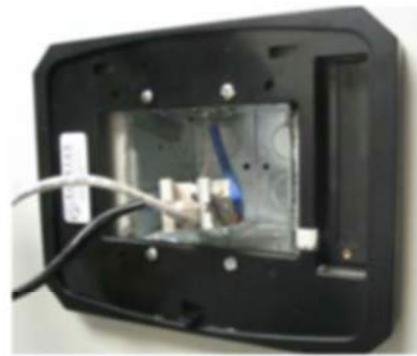

Figure 3: Flush Mount Bracket installation.



Design & Construction Standards



Surface Mount Bracket

The Surface Mount bracket mounts to a "shallow" surface-mount receptacle box such as Wiremold part #V5747-2, as shown in Figure 4. #6-32 screws (1 1/8" long) are required. The inside of the bracket includes prefabricated punch-outs for a variety of wiring conduit sizes, allowing connections from the top or bottom.



Figure 4: Surface Mount Bracket on Wiremold V5747-2 box.

Connecting Power to the Beacon

After determining the desired mounting option, the next step is to make the power connections. Select the procedure appropriate for the chosen power source.

Connecting DC Power

The Alert Beacon can operate on DC power from 13.4V to 24V, and requires a maximum of approximately 15W. The required barrel plug dimensions are 2.5mm inner diameter and 5.5mm outer diameter. To use DC power, simply connect the barrel plug to the appropriate jack on the Alert Beacon, as shown in Figure 2 (see page 2 of this guide.) After connecting power, proceed to the next section to select the appropriate DIP switch settings.

(Note: While it is possible to use a DC adapter for a wall-mount installation, this is not recommended. If 13.4V-24V DC is available, it can be connected using the Auxiliary Port connections similar to the AC power connection method described below, although care must be taken to observe the proper polarity.)

Connecting AC Power

AC power connections are made through the Alert Beacon's Auxiliary Port (green Euroblock connector.) Either a 12-position or 2-position plug can be used (typically, Alertus will ship a 2-position plug with the Alert Beacon when the customer is using AC power.) Make the connections according to the procedure below.



Figure 5: Connecting an AC transformer

For more information on the specifications and pinout of the Auxiliary Port, refer to the Alert Beacon Manual page on the Alertus support site at

http://support.alertustech.com/wiki/Beacon_Manual

- 1) Attach one end of a two-conductor cable to the AC power source. Refer to the Power Options section on page 2 for a list of suitable AC transformers, if required.
- 2) Strip the wires carrying the low voltage AC power and insert them into the terminal block plug, as shown in Figure 5 (above.)
- 3) Insert the plug into the terminal block on the back of the Alert Beacon.



Design & Construction Standards



Alert Beacon Installation Instructions (v6.2)

The Alert Beacon should now be receiving AC power. Proceed to the next section to select the appropriate DIP switch settings.

Connecting Power over Ethernet (PoE)

When using PoE, the only required connection is the data/power cable from the PoE data equipment. Use Category 5e or Category 6 cabling, with standard RJ-45 connectors. After connecting the cable as shown in Figure 6, proceed to the next section to select the appropriate DIP switch settings.



Figure 6: Connection when using PoE

DIP Switches

Certain aspects of the Alert Beacon's behavior can be configured using DIP switches, located on the back of the unit as shown in Figure 7. The switches are numbered from 1-3, and function as follows:

- DIP1 – Set to ON for Low Power Siren mode. This limits the maximum siren intensity and should be set when the Alert Beacon is installed in small or enclosed areas.
- DIP2 – Set to ON to allow the siren to be muted by pressing both front buttons. This is NOT recommended when installing in public areas! It is intended for use when the unit is installed in an administrative office (such as a police dispatch center) where continued siren operation may interfere with emergency response operations.
- DIP3 – Reserved for future use. This switch should remain set to OFF.



Figure 7: Power and DIP Switch Locations

Power Switch

The last step before attaching the Alert Beacon to a Mounting Bracket is to set the Power Switch to 'ON'



Design & Construction Standards



Alert Beacon Installation Instructions (v6.2)

Attaching an Alert Beacon to the Mounting Bracket

Once all required connections have been made and the appropriate DIP switches have been set, attached the unit to the mounting bracket using the following procedure:

1. While tilting the Alert Beacon towards the bracket as shown, attach the clips on the top rear under the slots on the bracket.
2. Once the top clips are in place, rotate the bottom edge of the unit towards the bracket while continuing to apply slight upwards pressure.





Design & Construction Standards



Alert Beacon Installation Instructions (v6.2)

3. After the Alert Beacon is fully aligned, apply firm pressure towards the wall until the unit is caught by the retaining clip. Ensure that the clip is holding the unit securely.



Security Screws

While the standard mounting bracket provides sufficient attachment for most locations, the bottom of the bracket also includes threaded inserts for security screws. These can be installed as a deterrent to accidental or malicious removal of the unit, or to provide additional tamper protection for units in isolated areas. These inserts require pan head #6-32 screws, 3/4" long (screws over 1" long may interfere with the electrical box.) For additional security, use tamper-proof screws such as the #6 spanner head (Screws and driver available from McMaster-Carr: P/N 94066A151 (screws) and 94062A114 (driver).) Note: Alertus does not include screws for this purpose due to the wide variety of tamper-proof screw designs on the market, and the fact that many organizations already have a preferred bit/driver type.

Post-Install Tasks

In order to properly configure the localized notification capabilities of the Alertus Notification system, administrators must have a record of the Unit ID and location of each Alert Beacon. Alertus provides Alert Beacon Install Logs for this purpose.

After completing an installation, record the 4-digit Unit ID (found on the white label on the rear of the unit, highlighted in Figure 8) and a short description of the unit's location, such as "Mathematics Building, East hallway near lobby" or "Smith Dorm, near main entrance".





Design & Construction Standards



ALERTUS

LOCALIZED EMERGENCY NOTIFICATION

Alert Beacon Installation Instructions (v6.2)

Removing an Alert Beacon

The release mechanism operates similar to a standard fire alarm. To remove a Alert Beacon, first remove the security screws (if applicable.) To release the retaining clip, insert a small flat-head screwdriver (or similar tool) into the slot on the bottom of the Alert Beacon housing. Press gently but firmly until the clip releases; continue to hold the clip while tilting the Alert Beacon upwards out of the mounting bracket. The stages of the release procedure are illustrated in the images below.

Figure 8: Location of Unit ID label





Design & Construction Standards



Alert Beacon Installation Instructions (v6.2)

Example: Flush Mounting (Hardwired AC transformer, FM Datalink)

1. Hardwired a step down transformer in a double gang electrical box.

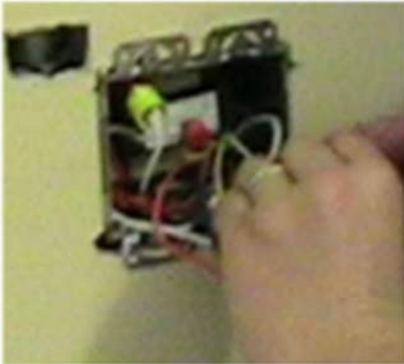

2. Drilled holes in faceplate for wires to come through. Two screws hold the face-plate and two screws secure the mounting bracket (next photo).

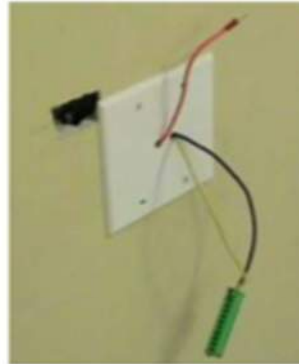

3. Installed mounting bracket onto double gang box with the transformer located inside.



4. Connected AC Power plug to Alert Beacon. (Note: The unit in this example received data over a wireless FM datalink; the green wire on the right was an antenna.)

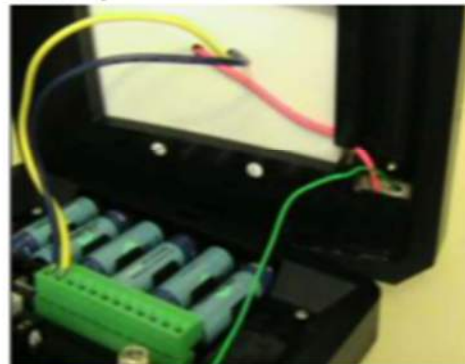



Design & Construction Standards



Alert Beacon Installation Instructions (v6.2)

Example: Surface Mounting (Hardwired AC transformer, FM Datalink)

1. 120VAC from a nearby emergency exit sign was brought into an electrical box installed above the drop ceiling.

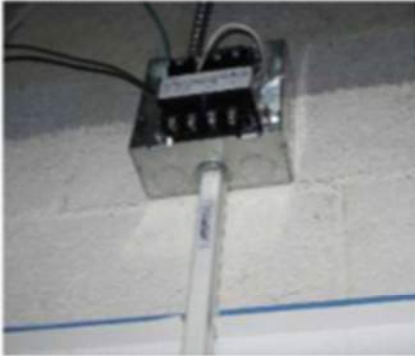

2. 500 Series Wiremold was brought down from the electrical box.



3. A Wiremold double-gang surface mount box was installed.



4. The Surface Mount Backplate screws into the Wiremold box.





Design & Construction Standards



Alert Beacon Installation Instructions (v6.2)

Example: Surface Mounting (Ethernet Datalink, with PoE)

1. 500 Series Wiremold installed with Cat6 Ethernet wiring inside.



2. Surface Mounting Bracket attaches to junction box (as above.)



3. Cat6 cable linked to appropriate PoE-enabled port in local wiring closet.





Design & Construction Standards



Appendix: Dimensional Drawings

Alert Beacon, front view

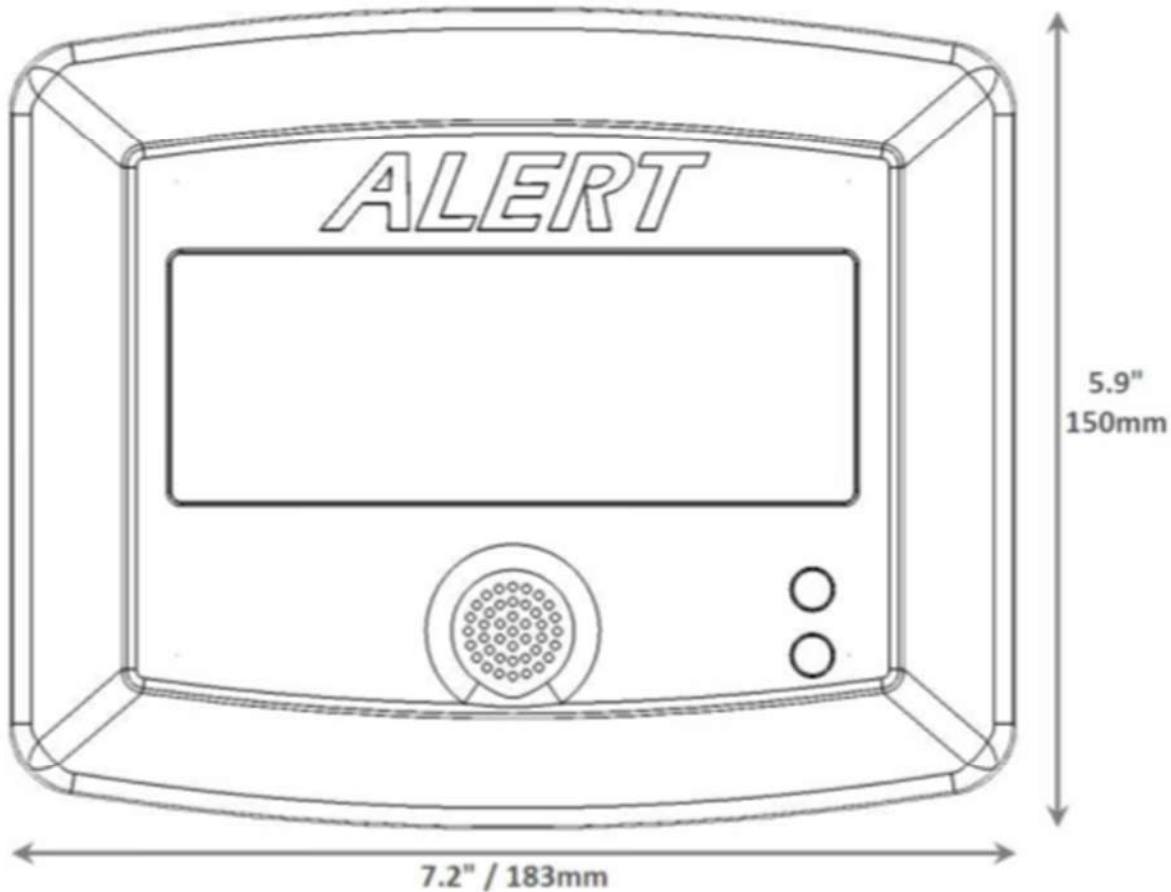



Design & Construction Standards



Alert Beacon, side views

Alert Beacon only

Alert Beacon attached to Flush Mounting Bracket v3

With Surface Mount Adapter

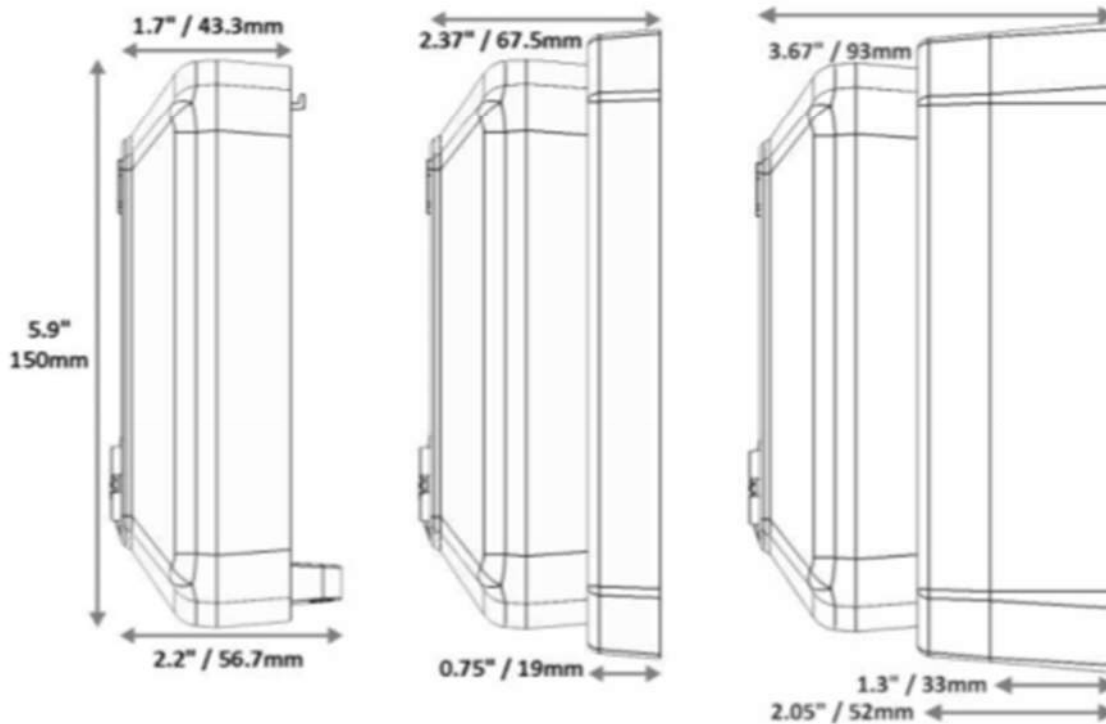



Design & Construction Standards



ALERTUS

LOCALIZED EMERGENCY NOTIFICATION

Alert Beacon Installation Instructions (v6.2)

Flush Mount Only

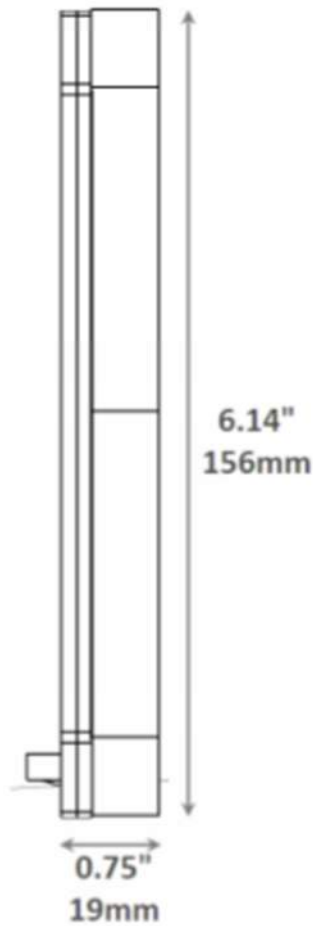

Design & Construction Standards

End of Division 27

Division 28: Electronic Safety & Security

28.0 General

Access Control Coordination

- A/E shall meet with the VCU Physical Plant Access Control Shop, and in consultation with the VCU Police and the VCU Lock Shop, to coordinate the access control system installation with the construction documents.

***Note to A/E:** If unable to arrange necessary meetings within a reasonable period of time, notify VCU Project Manager to request assistance, and if necessary an appropriate extension of time.*

A/E Responsibility

- A/E shall be responsible for all the hardware coordination.
- A/E shall be responsible for specifying all access control system pathways, conduit, access control and CCTV.
- A/E shall be responsible for coordinating the requirements from the access control coordination with VCU, and specifying them on the construction documents.

Access Control Security Closet

- Provide an access control and security closet for all new construction projects, separate from other required communications and data closets. The closet shall be a minimum of 6' x 4'. Full height 3/4" fire-rated Oriented Strand Board (OSB) shall be installed on all 3 walls. Conduit size shall be 3/4" minimum or larger, as required per the access control coordination.
- HVAC capacity to maintain ambient room temperature over the range 50 - 85°F 30 - 75% relative humidity (non-condensing), positive pressure with air exchange sufficient to dissipate heat generated by equipment.

Design & Construction Standards

28.1 Electronic Access Control & Intrusion Detection

Access Control System

- An access control system will be included in each new construction project and designated renovation projects.
- The access control system shall be powered by emergency power or standby generator, if available. Number of circuits will be determined based on equipment requirements provided by VCU. Sharing of neutral wires will not be allowed.
- Web-based access control programs shall be password protected.
- VCU Access Control Shop shall be involved in the testing of the Access Control System.
- A/E shall specify electric strike and key unlock from the outside for all rooms requiring panic buttons.

28.2 Electronic Surveillance

Closed-Circuit Television (CCTV) System

- VCU may provide a CCTV system in areas it deems appropriate.
- A/E shall meet with the VCU Police and the VCU Access Control Shop to coordinate the CCTV system installation with the construction documents.
- The access control system shall be powered by emergency power or standby generator, if available. The number of circuits will be determined based on equipment requirements provided by VCU. The sharing of neutral wires will not be allowed.

28.3 Fire Detection & Alarm

Fire Alarm Standards

- Fire alarm systems must meet code minimums. ANY design that goes beyond the code minimum must be signed off on by VCU prior to approval.

See "Division 21 Fire Suppression" section for fire sprinkler system standards.

Design & Construction Standards

- All fire alarm systems must be fully addressable.
- All fire alarm systems must transmit alarm and trouble signals to the central monitoring station immediately.
- All Fire Alarm Control Panels (FACP) must be located near the main entrance to the building.
- All fire alarm systems with an annunciator panel must make sure that the annunciator panel is fully operational.
- Smoke detectors are not to be installed in mechanical rooms, electrical rooms, transformer rooms, telephone equipment rooms, or similar rooms that are protected by an approved sprinkler system.
- Unless otherwise specified by the code, all buildings will have partial coverage fire alarm systems. (ex: R use group)
- When mounted above the ceiling, duct detectors must have a keyed remote indicator mounted below the ceiling.
- Use ceiling mounted horn / strobes when code allows.
- The University has four acceptable fire alarm manufactures:
 - Siemens
 - Simplex
 - Notifier
 - Firelite
- The A/E consultant shall specify that a pre-programming meeting be held with the fire alarm system installer, the VCU Project Manager, and the VCU Fire Safety representative.
- For complex applications, VCU may require the Contractor to mock-up the fire alarm system in their shop to verify ahead of time that the installation will meet VCU needs.
- Install dual lock Knox boxes on outside of building at main entrance. The dual lock Knox boxes must be tamper resistant, and be in the 4400 Series.
- Do not mix old fire alarm systems with new fire alarm systems; only one FACP per building.

VCU has had problems with the integration of fire alarm systems in the past, even if they are from the same manufacturer. These problems are due to the programming of the system when it is installed. By having VCU Fire Safety personnel present at the pre-programming meeting, we can ensure integration.

End of Division 28

Design & Construction Standards

Division 32: Exterior Improvements

32.8 Irrigation

Irrigation - General

- Irrigation equipment shall be:
 - Hunter
 - Rainbird
 - Toro
 - or equivalent.
- Plans for all landscape and irrigation designs shall be reviewed and approved by VCU Facilities Management - Physical Plant Grounds Supervisor.
- All commercial lawn irrigation systems shall require a pressure backflow preventer 12" above ground, and comply with water supply utility or authority requirements.
- All landscaped areas in new construction shall require irrigation systems.
- Install tracer wire per division 22.3 for all irrigation lines including main lines, lateral lines and supply lines.

End of Division 32