

	PAGE
<u>TABLE OF CONTENTS</u>	<u>1</u>
<u>INSTRUCTIONS TO PROFESSIONAL SERVICE PROVIDERS</u>	<u>2</u>
<u>GENERAL</u>	<u>3</u>
MSU Campus Planning Principles	
Document Standards	
Life Cycle Costing	
LEED™	
Universal Design Initiative	
Energy Conservation	
Energy Impact Statement	
<u>SITE</u>	<u>2</u>
See Site and Utility Infrastructure Guidelines	
<u>UTILITY INFRASTRUCTURE</u>	<u>20</u>
See Site and Utility Infrastructure Guidelines	
<u>SPACE ALLOCATIONS AND DESCRIPTIONS</u>	<u>13</u>
General	
Custodial Facilities	
Elevator Equipment Space	
Mechanical Spaces	
Electrical Spaces	
Other Spaces	
Interior Finishes	
<u>SAFETY</u>	<u>19</u>
Facility Protection	
Access Control	
<u>EXHIBITS</u>	<u>21</u>
Exhibit 1: CAMPUS MASTER PLAN	
Exhibit 2: DOCUMENT STANDARDS INFORMATION	
Exhibit 3: MSU BEST PRACTICES LEED™	
Exhibit 4: ENERGY IMPACT STATEMENT FORMAT	
Exhibit 5: CAMPUS COMMUNICATION ROOM SIZES	
Exhibit 6: LODAL PICKUP STATION DESIGN	
Exhibit 7: LEED™ PROJECT CHECKLIST	

INSTRUCTIONS TO PROFESSIONAL SERVICE PROVIDERS

- The Michigan State University Design Guidelines and the Michigan State University Construction Standards have been compiled for Architects, Engineers, and others retained to provide professional services for Michigan State University. They reflect the planning, construction, and maintenance experience of persons responsible for the university facilities.
- These standards for design and construction of buildings at Michigan State University have been prepared to achieve quality structures of maximum utility, requiring a minimum of maintenance and operating expense, and prudent use of energy.
- Adherence to the Design Guidelines and Construction Standards is mandatory unless a deviation has been approved in writing by the Michigan State University Design Representative. Any equal or improved concept, method, or product will be given full consideration.
- The Design Guidelines and Construction Standards are not intended to be used as specification items. The architects and engineers are expected to incorporate the items using their own wording and format unless otherwise directed.
- Sections of the Design Guidelines and Construction Standards will be revised and updated as experience or construction developments warrant. Each revised section supersedes all previous editions and directives concerning construction practices for Michigan State University. The Michigan State University website will always contain the most current version with the latest revision date indicated in red.
- The Design Guidelines and Construction Standards are prepared and published by: Engineering and Architectural Services, Infrastructure Planning and Facilities, Michigan State University.

GENERAL

1. MSU CAMPUS PLANNING PRINCIPLES

- A. The MSU Campus Planning Principles are included as part of The MSU Campus Master Plan.

2. DOCUMENT STANDARDS

- A. To facilitate record keeping by Engineering and Architectural Services, the format of project documents are restricted as follows:
- Specifications will be 8 ½" X 11" and will not have fold-out pages. Paper will be white. They will be permanently bound.
 - Drawings will be standard sizes and bound as a set. Maximum size will be 42" X 30".
 - Titles will reflect the official project name, CP number, EAS project team, and Drawing name, page number and total number of pages,.
- B. Engineering and Architectural Services will provide direction for room/space numbering.
- C. Additional direction on specification formatting is found in Exhibit 2

3. LIFE CYCLE COSTING

- A. Life cycle costing shall be an integral part of the design process. Most campus buildings are intended to last an indeterminate amount of time so adaptable facilities and planned maintenance are the norm, rather than short-term, write-off solutions. Simplicity of construction makes new construction and future alterations less expensive.

4. LEED™

- A. It is the intent of Michigan State University that all new buildings and major remodeling projects will be designed to qualify for LEED™ Silver Certified using the most current version available. Certification will be addressed on a case by case basis.
- B. Certain sections of the Design Guidelines and Construction Standards have been modified to guide accomplishment of this goal. It is the responsibility of the Project Architect or Engineer (A/E) to review these and other applicable LEED™ v3 criteria for appropriate inclusion. Also see Exhibit 3, MSU BEST PRACTICES LEED™ and Exhibit 7, LEED™ 2009 for New Construction and Major Renovations, Project Checklist.
- C. For all projects, the Construction Waste Management form and the applicable version of Specification Section 024200 (PO or Minor/Major) will be included in the bid documents. For Purchase Order projects (budget less than \$250,000), the Contractor is required to complete and submit the form only. For Minor and Major projects (budget \$250,000 or greater), the Contractor is required to comply with LEED™ 2009 Materials and Resources Credit 2.

- D. At minimum, all projects shall meet requirements of the following Prerequisites and Credits in the LEED™ 2009 for New Construction and Major Renovations with all applicable errata and amendments:
- SS Prerequisite 1: Construction Activity Pollution Prevention
 - ◇ Intent: To reduce pollution from construction activities by controlling soil erosion, waterway sedimentation, and airborne dust generation.
 - ◇ Create and implement an erosion and sedimentation control plan during the design phase of the project.
 - SS Credit 8: Light Pollution Reduction
 - ◇ Light trespass shall be eliminated from the building and site to improve night sky access and reduce development impact on nocturnal environments.
 - ◇ Design interior lighting to comply with either Option 1 or Option 2 of this credit.
 - Option 1 – Automatically reduce the input power of all nonemergency interior luminaires with a direct line of sight to any openings in the envelope by at least 50 percent between 11 p.m. and 5 a.m. After-hours override shall be provided by a manual or occupant-sensing device provided the override lasts no more than 30 minutes.
 - Option 2 – All openings in the envelope with a direct line of sight to any nonemergency luminaires must have shielding (controlled/closed by automatic device for a resultant transmittance of less than 10 percent between 11p.m. and 5 a.m.)
 - ◇ Only light areas as required for safety and comfort. Lighting power densities shall not exceed ASHRAE/IESNA Standard 90.1-2010 Exterior Lighting Section with Addenda 1 and shall comply with the control requirements.
 - ◇ Classify the project as LZ1, LZ2, LZ3 or LZ4 as appropriate under the IESNA RP-33 and follow requirements of that zone.
 - ◇ Design exterior lighting such that the maximum % lumen emitted does not exceed that allowable for the LZ at an angle above 90° or higher from straight down as established by ASHRAE/IESNA Standard 90.1-2010 Exterior Lighting Standards and LEED™ 2009 SS credit 8 Light Pollution Reduction.
 - WE Prerequisite 1: Water Use Reduction
 - ◇ Intent: To increase water efficiency within buildings.
 - ◇ Use 20% less water than the water use baseline calculated for the building.
 - ◇ Use high efficiency fixtures.
 - WE Credit 1: Water Efficient Landscaping
 - ◇ Intent: To limit the use of potable water for landscape irrigation.
 - ◇ Reduce potable water consumption for irrigation by 50%.
 - ◇ Consider using plant species, density and microclimate factor; irrigation efficiency; and use of captured rainwater.
 - WE Credit 3: Water Use Reduction
 - ◇ Intent: To further increase water efficiency within buildings.
 - ◇ Use 30% less water than the water use baseline calculated for the building.
 - ◇ Use high efficiency fixtures.

- ◇ Consider using rainwater for nonpotable applications.
- EA Prerequisite 1: Fundamental Commissioning of Building Energy Systems
 - ◇ Intent: To verify that the project's energy related systems are installed and calibrated to perform according to the owner's project requirements, basis of design and construction documents.
 - ◇ Engage a CxA in the design process.
 - ◇ Determine owner's project requirements, develop and maintain commissioning plan for use during design and construction and Determine owner's project requirements, develop and maintain commissioning plan for use during design and construction and incorporate commissioning requirements in bid documents.
 - ◇ Assemble the commissioning team, and prior to occupancy verify the performance of energy consuming systems.
 - ◇ Complete commissioning reports with recommendations prior to accepting the commissioned systems
- EA Prerequisite 2: Minimum Energy Performance
 - ◇ Intent: To establish the minimum energy efficiency level for the proposed buildings and systems.
 - ◇ Use Whole Building Energy Simulation Option. Comply with specific requirements of ASHRAE/IESNA Standard 90.1-2010 (with errata but without addenda). Where applicable, the designer may alternatively use the other compliance options available in LEED™ EA Prerequisite 1 to demonstrate the required improved performance percentage.
 - ◇ Use a computer simulation model to assess the energy performance and identify the most-cost effective energy efficiency measures.
 - ◇ Quantify energy performance compared with a baseline building.
- EA Prerequisite 3: Fundamental Refrigerant Management
 - ◇ Intent: To reduce stratospheric ozone depletion.
 - ◇ Zero use of CFC-based refrigerants.
- EA Credit 1: Optimize Energy Performance
 - ◇ Intent: To improve on the energy performance level.
 - ◇ Use Whole Building Energy Simulation Option. Design and specify systems and components such that building energy performance is a minimum of 30% better for new buildings and 26% better for existing buildings than the base requirements of the ASHRAE/IESNA Standard 90.1- 2010 (with errata but without addenda) using a whole building analysis method allowed under the standard. Where applicable, the designer may alternatively use the other compliance options available in LEED™ EA Credit 1 to demonstrate the required improved performance percentage.
 - ◇ Use a computer simulation model to assess the energy performance and identify the most-cost effective energy efficiency measures.
 - ◇ Quantify energy performance compared with a baseline building.
- EA Credit 2: On-site Renewable Energy
 - ◇ Intent: To reduce environmental and economic impact associated with fossil fuel energy use.

- ◇ Minimum renewable energy is 1% of the building's annual energy cost.
- ◇ Renewable energy potential includes solar, wind and geothermal
- EA Credit 4: Enhanced Refrigerant Management
 - ◇ Intent: To reduce ozone depletion.
 - ◇ Select HVAC&R equipment that minimize or eliminate the emission of compounds that contribute to ozone depletion and climate change.
- EA Credit 5: Measurement and Verification
 - ◇ Intent: To provide for the ongoing accountability of building energy consumption over time.
 - ◇ Use either Option D: Calibrated Simulation or Option B: Energy Conservation Measure Isolation as specified in the International Performance Measurement & Verification Protocol (IPMVP) Volume III: Concepts and Options for Determining Energy Savings in New Construction.
- MR Prerequisite 1: Storage and Collection of Recyclables
 - ◇ Intent: To facilitate the reduction of waste generated by building occupants that would otherwise be hauled to and disposed of in landfills.
 - ◇ Design and allocate an easily accessible dedicated space serving the entire building for recycling of office paper, newspaper, other paper items, corrugated cardboard, glass, plastics and metals.
 - ◇ Design the recycling space such that it supports campus building collection methods. Obtain design input and review from the MSU Recycling and Waste Management Office (<http://www.recycle.msu.edu/>).
- MR Credit 2: Construction Waste Management
 - ◇ This credit requires diversion of construction and demolition debris from disposal and incineration facilities. Redirect recyclable recovered resources back to the manufacturing process and reusable materials to appropriate sites.
 - ◇ Recycle and/or salvage nonhazardous construction and demolition debris.
 - ◇ Develop and implement a construction waste management plan that, at a minimum, identifies the materials to be diverted from disposal and whether the materials will be sorted on-site or commingled.
 - ◇ Excavated soil and land-clearing debris do not contribute to this credit.
 - ◇ Calculations can be done by weight or volume, but must be consistent throughout.
 - ◇ The minimum percentage debris to be recycled or salvaged for each point threshold is follows:
 - Recycled or Salvaged – 50% - 1 point (Minimum)
 - Recycled or Salvaged – 75% - 2 points (Evaluate based on project)
- MR Credit 4: Recycled Content, 20% (post-consumer + ½ pre-consumer).
 - ◇ This credit requires the use of an additional 10% of materials beyond credit MR Credit 4.1 with recycled content such that the sum of post-consumer plus one-half of the post industrial content constitutes at least 10% of the total value of the materials in the project.
 - ◇ Select and specify the use of materials with recycled content such that the sum of post-consumer plus one-half of the post-industrial content constitutes at least 20% of the total value of the materials in the project. Materials classified as recycled

shall meet the definitions of “Post-consumer” and “Pre-consumer” established in the LEED™ Credit 4.1. Exclude mechanical, electrical, plumbing and specialty items such as elevators and materials not permanently installed in the building from the calculation. Refer to ISO 14021-Environmental Labels and Declarations-Self Declared environmental claims (Type II environmental labeling).

- ◇ Specify that the contractor develop and implement documentation necessary to establish that the recycled materials are used during construction.
- MR Credit 5: Regional Materials, 10% Extracted, Processed & Manufactured Regionally
 - ◇ Intent: To use materials that are manufactured and extracted locally in order to reduce environmental impacts of transportation, use indigenous resources and support the local economy.
 - ◇ Specify materials that have been extracted, harvested and manufactured within 500 miles of the project site, such that the value of these materials total at least 10% of materials used in the project. Exclude mechanical, electrical, plumbing and specialty items such as elevators, and materials not permanently installed in the building from the calculation.
 - ◇ Include in project specifications, contractor submittal and documentation requirements necessary to demonstrate compliance by contractors during construction.
- IEQ Prerequisite 1: Minimum Indoor Air Quality Performance
 - ◇ Intent: To establish minimum IAQ performance to enhance IAQ in buildings.
 - ◇ Design ventilation systems to meet or exceed the minimum outdoor air ventilation rates as described in the ASHRAE Standard 62.1-2007, Ventilation for Acceptable Indoor Air Quality (with errata but without addenda).
- IEQ Prerequisite 2: Environmental Tobacco Smoke (ETS) Control
 - ◇ Intent: To prevent or minimize exposure of building occupants, indoor surfaces and ventilation air distribution systems to ETS.
 - ◇ Prohibit smoking in buildings.
- IEQ Credit 1: Outdoor Air Delivery Monitoring
 - ◇ Intent: To provide capacity for ventilation system monitoring.
 - ◇ Install CO2 and airflow measurement equipment and feed the information to the HVAC equipment and BAS to trigger corrective action.
- IEQ Credit 3.1: Construction IAQ Management Plan: During Construction
 - ◇ Intent: To reduce IAQ problem resulting from construction or renovation.
 - ◇ Adopt an IAQ management plan.
 - ◇ Sequence the installation of materials.
 - ◇ Coordinate with IEQ Credit 3.2 and IEQ Credit 5.
- IEQ Credit 3.2: Construction IAQ Management Plan: Before Occupancy
 - ◇ Intent: To reduce indoor air quality problems resulting from construction operations.
 - ◇ Compliance with this requirement will largely depend on project schedule. The designer therefore shall plan for either the flush-out periods or testing options included in LEED™ IEQ credit 3.2.

- ◇ Specify both testing and flush-out procedures in the contract documents.
- ◇ Include in project specifications contractor submittal and documentation requirements necessary to demonstrate compliance.
- IEQ Credit 4.1: Low-Emitting Materials: Adhesives and Sealants
 - ◇ Intent: To reduce the quantity of harmful or irritating indoor air contaminants which result from building materials.
 - ◇ Compliance with this credit is not mandatory when in the judgment of the specifier and concurrence of MSU that products that would meet this sustainability requirement would not perform in other respects.
 - ◇ Specify adhesives and sealants for interior applications which meet the maximum VOC content requirements of the South Coast Air Quality Management District Rule #1168, effective date July 1, 2005 and amendment date January 7, 2005.
 - ◇ Specify that Aerosol Adhesives comply with the Green Seal Standard for Commercial Adhesives GS-36 requirements in effect on October 19, 2000.
 - ◇ Specifiers should recognize that installation of some systems may include the incidental use of sealants and adhesives. The specifier should take care in preparing specifications for all systems which may use any adhesives or sealants to include these sustainability requirements.
 - ◇ The specifier should carefully consider all performance criteria and select only products which meet other necessary performance criteria in addition to the sustainability criteria.
 - ◇ Include in project specifications, contractor submittal and documentation requirements necessary to demonstrate compliance by contractors during construction.
 - ◇ The design team shall submit a summary list of applications and products specified which do not comply with this standard.
- IEQ Credit 4.2: Low-Emitting Materials: Paints and Coatings
 - ◇ Intent: To reduce the quantity of harmful or irritating indoor air contaminants which result from building materials.
 - ◇ Compliance with this credit is not mandatory when in the judgment of the specifier and concurrence of MSU that products that would meet this sustainability requirement would not perform in other respects.
 - ◇ Specify paints and coatings which are to be field applied to interior surfaces which meet the maximum VOC and chemical content limitation of the following:
 - Architectural paints, coatings and primers applied to interior walls and ceilings shall comply with Green Seal's Standard GS-11, Paints First Edition, May 20, 1993. For VOC requirements and list of prohibited chemicals see www.greenseal.org/standards/paints.htm.
 - Anti-corrosive and anti-rust paints applied to interior ferrous metal: Green Seal Standard GC-03. Anti-Corrosive Paints, Second Edition, January 1997.
 - Clear wood finishes, floor coatings, stains and shellacs applied to interior elements: shall comply with the South Coast Air Quality Management District Rule #1113, effective date January 1, 2004.
 - ◇ Specifiers should recognize that installation of some systems may include the incidental use of paints and coatings. The specifier should take care in preparing

- specifications for all systems which may use any paints or coatings to include these sustainability requirements.
- ◇ The specifier should carefully consider all performance criteria and select only products which meet other necessary performance criteria in addition to the sustainability criteria.
 - ◇ Include in project specifications, contractor submittal and documentation requirements necessary to demonstrate compliance by contractors during construction.
 - ◇ The design team shall submit a summary list of applications and products specified which do not comply with this standard.
- IEQ Credit 4.3: Low-Emitting Materials: Carpet
 - ◇ Intent: To reduce the quantity of harmful or irritating indoor air contaminants which result from building materials.
 - ◇ Specify Carpets and cushion pads that meet The Carpet and Rug Institute's CRI Green Label™ Plus program www.carpet-rug.org.
 - ◇ Limit carpet adhesive VOC contents to those required by LEED™ IEQ 4.1: VOC limit of 50 g/l.
 - ◇ The specifier should carefully consider all performance criteria and select only products which meet other necessary performance criteria in addition to the sustainability criteria.
 - ◇ Include in project specifications, contractor submittal and documentation requirements necessary to demonstrate compliance by contractors during construction.
 - IEQ Credit 5: Indoor Chemical & Pollutant Source Control
 - ◇ Intent: To avoid exposure of building occupants to potentially hazardous chemicals that adversely impact air quality.
 - ◇ Design permanent entry way systems for regular building user entry points, which use permanently installed grilles that allow for cleaning in accordance with LEED™ IEQ Credit 5.
 - ◇ Meet the exhaust system and air requirements of LEED™ IEQ Credit 5 for building service areas including housekeeping, laundries, copy/printing rooms, garages where hazardous gases or chemicals may be present.
 - ◇ Design service areas to meet the enclosure and separation requirements of LEED™ IEQ Credit 5.
 - ◇ Design service areas to meet the enclosure and separation requirements of LEED™ IEQ Credit 5.
 - IEQ Credit 6.1: Controllability of Systems, Lighting
 - ◇ Provide a high level of lighting system control by individual occupants or specific groups in multi-occupant spaces such as classrooms and conference areas to promote productivity, comfort and well being of building occupants.
 - ◇ Design individual lighting system controls for 90% of occupants to enable lighting adjustments to suit individual task needs and preferences.
 - ◇ Plan for lighting controls for multi-occupant spaces such as classrooms and conference areas to enable lighting adjustment that meets group needs and preferences
 - IEQ Credit 7.1: Thermal Comfort – Design

- ◇ Intent: To provide a comfortable thermal environment.
- ◇ Design the HVAC systems and the building envelope to meet the requirements of ASHRAE Standard 55-2004, Thermal Comfort Conditions for Human Occupancy (with errata but without addenda.)
- IEQ Credit 7.2: Thermal Comfort – Verification
 - ◇ Intent: To provide for the assessment of building occupant thermal comfort over time.
 - ◇ Establish thermal comfort criteria and documenting and validating building performance to the criteria.

E. Documentation Requirements

- Design Team shall submit required MSU Sustainability Documentation showing compliance with this standard in accordance with the MSU Sustainability Documentation Requirements.
- For projects which are to be LEED™ registered and certified submit LEED™ on-line Design Stage and Post Construction documentation as required showing compliance with this standard.

F. When proposing the use of any other LEED™ standards comply with the following:

- Comply with the intent, design and construction parameters and document requirements of the appropriate standard of the LEED™ NC 2009 for New Construction and Major Renovations, with all applicable errata and amendments.
- Consider other appropriate cost and performance criteria, in addition to the LEED™ “sustainability” requirements when designing, selecting and detailing systems and specifying products and processes. To the extent possible meet the other performance criteria included in the posted MSU Construction Standards.
- Identify and submit summaries of required deviations from the posted MSU Construction Standards in support of the specific LEED™ standard selected.
- Include construction details and specifications and administrative requirements in contract documents necessary to comply with the LEED™ standard.

5. UNIVERSAL DESIGN INITIATIVE

A. It is the intent of Michigan State University to develop a built environment which is universally designed to accommodate persons with disabilities as an integral element in anything built or purchased. The designer will take the initiative to provide these accommodations, which are not separate or special, but rather are universal in utility. Successful examples that accommodate the greatest diversity of human characteristics and enhance esthetics are:

- Grade level building approaches with automatic snow melting rather than separate unheated ramps and steps provide hazard-free entrances for everyone.
- Signs on automatic doors that read “automatic door: rather than a barrier free logo. Mobility aid users can select which door to use like everyone else.
- Lever-handle hardware, which is more convenient for everyone.

- Exit signs that flash when an emergency alarm is activated, which reinforces that an emergency exit condition exists and warns the hearing impaired as well.
- Low service counters, where possible, to be equally functional for wheelchair-users and non-wheelchair-users.
- Room number signs with raised or incised characters, which can be read by touch as well as by sight, and at a standard mounting height.
- Vertical sliding chalkboards in a percentage of classrooms and other areas, which provide increased writing area and a better view for everyone.

6. ENERGY CONSERVATION

- A. Identify energy-efficiency measures. Evaluate energy efficiency of proposed new construction, building expansion, remodeling, and new equipment purchases. Estimate savings and implementation costs. Implement approved energy-efficiency measures.
- B. All new buildings and additions shall be designed to reach an energy conservation target of 30% below ASHRAE standards. Identify additional ECMs that would reduce the energy usage to 45% below ASHRAE standards.
- C. For new construction and major renovation projects, perform a whole building project simulation. The proposed design must be compared against a baseline building that complies with Appendix G of the ASHRAE/IESNA Standard 90.1-2010, and also against a baseline building that complies with MSU Construction Standards.
- D. Opportunities for additional savings include the following:
 - Building Envelope: Reduce heat conduction through roofs and walls. Reduce infiltration. Control or reduce solar heat gains. Reduce heat conduction and long wave radiation.
 - Lighting Systems: Reduce illumination levels. Improve lighting system efficiency. Curtail operating hours. Use daylighting.
 - HVAC Systems: Improve equipment performance. Provide water side economizers. Reduce ventilation requirements to minimum acceptable levels.
 - HVAC Distribution Systems: Optimize the distribution system to reduce the energy required to transport fluids and to reduce the energy losses during transport.
 - Energy Management Control Systems: Select optimum equipment operating times and setpoints as a function of electrical demand, time, weather conditions, occupancy, and heating and cooling requirements.
 - Power Systems: Use high efficiency motors to improve the power system efficiency.
 - Water Heating Systems: Improve equipment performance. Reduce distribution losses.

- Heat Recovery Systems: Apply where there is a need to reject heat from a constant supply of high temperature air, water, or refrigerant.
- Renewables: Solar, wind, geothermal and rainwater.
- Building Operation: Lower the heating and raise the cooling temperature setpoints to minimize the space conditioning requirements whenever possible. Lower the humidification setpoints and raise the dehumidification setpoints to minimize the space conditioning requirements whenever possible.

7. ENERGY IMPACT STATEMENT

- A. An Energy Impact Statement is required for each project in accordance with the individual design services contract. Appropriate format for the document is found in Exhibit 4.

SPACE ALLOCATIONS AND DESCRIPTIONS

1. GENERAL

- A. A program statement will be provided by the Engineering and Architectural Services. This statement will establish specific space and other project parameters to satisfy departmental or university needs, such as number, size, and descriptions of office spaces, laboratories, meeting rooms, auditoriums, etc. The descriptions of spaces that follow apply to all university construction.
- A. LEED: It is the intent of MSU that its building designs will meet the design requirements of MR Prerequisite 1: Storage and Collection of Recyclables of LEED™ 2009 For New Construction and Major Renovation with all applicable errata and amendments. The intent of the prerequisite is to facilitate the reduction of waste generated by building occupants that would otherwise be hauled to and disposed of in landfills.

2. CUSTODIAL FACILITIES

- A. Custodial Room: Each building will have one room meeting the following requirements for the exclusive use by the custodial staff:
- Locate near the service/freight elevator if one is provided in the building.
 - One service sink will be provided.
 - Walls behind and near the service sink and time clock will be filled and finished with epoxy paint. Other walls will be unpainted.
 - Provide heat and ventilation same as other rooms in the building.
 - This space is not to be used as a mechanical room or to be in a mechanical room.
 - Provide six single-circuited 120V, 20A duplex receptacles in one wall for recharging floor maintenance equipment and several additional duplex convenience receptacles in each wall.
 - Provide a communications outlet for Ethernet connection and telephone connection.
 - Space requirements for the room are as follows:

	<u>Building Size</u>	<u>Approximate Space Required</u>
◇	0 – 50,000 sq.ft.	200 sq.ft.
◇	100,000 – 200,000 sq.ft	600 sq.ft.
◇	200,000 or more sq.ft.	700 sq.ft.

- B. Custodial Closets: Provide at least one custodial closet per floor, meeting the following requirements:
- Shelves on one wall 12” wide, 18” apart, first shelf 24” from the floor. Heavy duty K&V adjustable shelf tracks or equal.
 - One service sink will be provided.
 - All walls in custodial closets will be filled and finished with epoxy paint or other waterproof finish material such as glazed block, as approved.

- Mop rack over sink and mixing faucet 24” from the floor.
- Sealed concrete floor
- The closets will have ventilation and, when on an outside wall, will be heated.
- This space will not be used as a mechanical room or have mechanical equipment located in it, except for an inspector’s test station for a sprinkler system when such a room affords the most convenient location.
- Space Requirements for the room are as follows:

	<u>Building Size</u>	<u>Approximate Space Required</u>
◇	0 – 100,000 sq.ft.	6 ft. by 6 ft.
◇	100,000 or more sq.ft.	8 ft. x 12 ft.

C. ELEVATOR EQUIPMENT SPACE

- Traction elevators are preferred over hydraulic elevators for higher frequency use, faster than 125 fpm over four stops, and high load installations. Consult with Engineering and Architectural Services.
- Hydraulic elevators will have their hoisting equipment located within 25 ft. of the hoistway and at the lowest landing of the elevator. Traction elevators will be overhead traction type with the machine room above the shaft in the attic or penthouse.
- When the size of the building or the occupancy justifies two elevators, they should be installed immediately adjacent to each other.
- Machine space will be separate from any other, and accessible from within the building via stair if it all possible. Ladders or roof access are unacceptable.
- Provide heat and/or ventilation and cooling as required to maintain machine room between 60 degrees F and 85 degrees F where electronic controllers are permitted by MSU.
- One elevator will be connected to the emergency generator.
- Provision will be made for lifting traction hoist equipment in and out of the machine room from the bottom floor of the building. Provide a removable concrete panel in the floor, and a hoist beam on the machine room ceiling in line with the hoist equipment and the floor opening, or equal.
- Provide a communications outlet for Ethernet connection.

D. MECHANICAL SPACES

- This section contains information that serves as general requirements for mechanical space design. Refer to applicable codes and standards for further information on the criteria mentioned in this section.
- Refer to the MECHANICAL DESIGN section of this document for mechanical design requirements and to appropriate sections in the MSU Construction Standards for additional design considerations.

- Separate spaces shall be provided for departmental equipment requiring access by department personnel so security can be maintained on building equipment. The departmental equipment shall not be located in building mechanical rooms.
- Orient mechanical rooms to outside utility services. Provide doors and areaways to the outside as required for replacement of heavy equipment.
- Penthouse mechanical rooms are desirable for buildings requiring mechanical spaces at a higher level. Provide natural light in penthouse.
- Mechanical spaces should be accessible to maintenance personnel without extensive travel through finished areas.
- Provide elevator service to the mechanical rooms where possible for delivery of operating materials, such as softener salt, water treatment chemical, etc. Mechanical rooms shall be accessible by stairs, not ladders.
- Mechanical spaces housing high heat generating equipment shall be adequately insulated and ventilated to protect adjoining areas. Rooms containing high heat generation equipment require thermal insulation from adjoining spaces.
- Building gas meter shall be located on the exterior.
- Provide at least one 3" floor drain in every mechanical room.
- Provide a communications outlet adjacent to the main Central Control cabinet for the building for Ethernet connection.

E. ELECTRICAL SPACES

- Electrical Space Design Requirements
 - ◇ Departmental equipment requiring access by departmental personnel shall be located in spaces separate from building transformer vaults, electrical rooms, telephone rooms, communication rooms, etc., so security can be maintained on building equipment and systems.
 - ◇ Do not locate transformer vaults under wet areas. Orient transformer vaults adjacent to exterior walls for access of underground electrical service. Provide doors and areaway to outside as required to provide means of replacing transformer equipment.
 - ◇ Emergency Generator Rooms will be located on an exterior wall and be adequately ventilated.
 - ◇ In general, electrical panels shall be located in electrical closets to provide for new and future conduit and cable installation. Sufficient empty wall space shall be provided for future electrical panels and equipment.
- Communication Space Design Requirements
 - ◇ Main Communication Rooms
 - Campus communications utilities will enter the building at the Telephone Utility Room and the Broadband Utility Room. A User Communication Room will be provided to accommodate departmental communication equipment. The types, service, and size of these three rooms shall be as shown in Exhibit 5.

- Ideally, the User Communication Room would be located between the Broadband Utility Room and the Telephone Utility Room with a cable passage between each room.
 - Minimum ceiling height shall be 10 feet.
 - All three rooms will have the floor tiled and the walls painted white. Three walls of the Telephone Utility Room will be covered with 4' x 8' x ¾" plywood. The Broadband Utility Room shall have a lay-in ceiling to minimize dust from the ceiling cavity above entering fiber optic equipment.
 - Provide heat and/or ventilation or cooling to maintain rooms between 60 degrees and 85 degrees Fahrenheit.
 - All communication rooms will have locksets. Infrastructure Planning and Facilities (IPF) space shall be on IPF keying.
 - Each of the main communication rooms shall have two double duplex receptacles installed. Each double duplex shall be on its own circuit.
- ◇ Floor Communication Rooms
- At least one Floor Communication Room shall be provided on each floor. These rooms will house telephone switching and broadband equipment. Locate the Floor Communication Rooms central to the area they will serve, and in vertical alignment from floor to floor, to facilitate routing of large connecting conduits. Each of the Main Communication Rooms will feed the closest Floor Communication Room.
 - Room shall be a minimum of 9' x 9' with an 8' ceiling. The door shall open out into the corridor. Two walls will be covered with 4' x 8' x ¾" plywood. The rooms will be under the control of Infrastructure Planning and Facilities. All communications rooms will have locksets.
- ◇ Floor User Communications Rooms
- At least one Floor User Communication Room shall be provided on each floor. These rooms will house User Communication equipment. Locate the Floor User Communication Rooms adjacent to the Floor Communication Rooms. The number of Floor User Communication Rooms may have to be increased so that the longest run of any Category 5 ethernet cable is not greater than 300' (90m).
 - Room shall be a minimum 8 ft. x 8 ft. with a 8 ft. ceiling height. Refer to EIA/TIA 569 for additional room requirements. The door shall open out into the corridor. The rooms will be under the control of the Department. All communication rooms will have locksets. Other utilities shall not pass through communication rooms in order to keep the ceiling space clear for routing of communication cables and installation of communication cable trays.

F. OTHER SPACES

- Solid Waste Management: Solid waste is removed from the University by Grounds Maintenance in trucks equipped with front-end local container handling equipment and self-contained compactors. Provide an enclosed Local Pickup Station in accordance with the detail in Exhibit 6. This room shall have a floor drain to the sanitary sewer.
- Recycling: Design and allocate an easily accessible dedicated space serving the entire building for the recycling of office paper, newspaper, other paper items, corrugated

cardboard, glass, plastics, and metals. Design the recycling space such that it supports campus building collection methods. Obtain design input and review from the MSU Recycling and Waste Management Office <http://www.recycle.msu.edu/>. The design team shall submit required MSU Sustainability Documentation showing compliance with this standard in accordance with the MSU Sustainability Documentation Requirements. For projects which are to be LEED registered and certified, submit LEED on-line Design Stage and Post Construction documentation as required showing compliance with this standard.

- Vending Machine Space: Provide an alcove or similar space off a main corridor for vending machines.
- Unisex Restroom: There will be a minimum of one unisex restroom on each floor of all new buildings or additions.

G. INTERIOR FINISHES

- Interior surfaces that require painting should be kept to a minimum. Because a percentage of University facilities are constantly being altered for new uses, the designer should consider selecting materials that can be matched or easily duplicated in the future so as to allow future designers to patch and repair to match existing while maintaining the original design intent.
- To prevent acoustical transfer, all interior walls should extend to the deck above. Masonry or full bed plaster walls are preferred over veneer plaster/metal stud walls. Drywall partitions are not normally acceptable except for ceilings or wall spaces above suspended ceilings.
- Heavy traffic areas such as corridors, lobbies, waiting areas, stairways, etc., shall have a durable, washable wall finish. The preferred wall surface for these areas is structural glazed facing tile. If the building design requirements dictate an alternate surface, vinyl wall covering should be used.
- All windows with the potential to have blinds or draperies in the future will be provided with 2" X 12" solid wood blocking at the ceiling to support window treatment. The blocking will be provided to accommodate a drapery and liner rod, or blinds, whether they are used or not. Coordinate required blocking with the appropriate trades.
- Draperies should hang in front of window stools to prevent the uneven look of draperies ending above the stool. If blinds are used, they will not be less than three (3) inches from the interior surface of the glass.
- All first floor corridors and other heavy traffic areas should have terrazzo floors. Carpeted areas will be permitted only with the approval of the Engineering and Architectural Services.
- All stair handrails will be continuous. Minimum vertical headroom shall be 8'0".
- Heavy traffic stairs shall have stainless steel handrails and balustrades attached to the side of the stringer, poured in place terrazzo treads with six inch abrasive tile nosing or carborundum/epoxy strips poured into formed strips in the terrazzo treads. Avoid aluminum or cast iron nosings because they work loose, crack or crack concrete, and corrode, especially at stairs near entrances.

- Light traffic stairs shall have rubber treads and painted steel handrails and painted steel balustrades with high performance urethane finish.
- Loading dock stairs or other exterior utility stairs shall be cast concrete with troweled carborundum/epoxy treads. Handrails shall be hot dipped galvanized or stainless steel.

SAFETY

1. FACILITY PROTECTION

- A. Protective systems involving fire, security, and access control shall be reviewed with the Department of Police and Public Safety regarding the scope of work and the type of systems to be implemented.
- B. Automatic Sprinklers: All new major buildings will have automatic sprinklers throughout. (See Construction Standards Division 21 – Section 211313 WET-PIPE SPRINKLER SYSTEMS.
- C. Detection and Alarm: All new buildings will have a protected premises fire alarm system consisting of pull stations, area and duct smoke detectors, and evacuation alarms/strobes throughout the building. (See DESIGN GUIDELINES – ELECTRICAL DESIGN and Construction Standards Section 283100 – Detection and Alarm).
- D. Fire Hose Standpipes
 - Threading on hose connections shall match MSU equipment.
 - All new buildings over two stories above ground will have fire hose standpipes in accordance with NFPA Code and as follows:
 - Standpipes will normally be wet systems placed in stairwells, and be interconnected. Intermediate risers may be needed in long buildings.
 - Hoses will not be provided. Provide both Siamese and O.S. & Y. connections.
- E. Fire Extinguishers: Fire extinguishers will be furnished and installed by the MSU Department of Police and Public Safety, unless otherwise specified. (See Construction Standards Section 104400 – Fire Protection Specialties)
- F. Miscellaneous: The following items are commonly installed wherever conditions warrant their use:
 - Breather Mask Cabinets (See Section 104400 – Fire Protection Specialties)
 - Valve Cabinets: For emergency shut-off of laboratory gas.
 - Fire Blanket Cabinets
 - Emergency Showers (See Construction Standards Section 224500 – EMERGENCY PLUMBING FIXTURES)

2. ACCESS CONTROL

- A. A Siemens access control system compatible with the access control system located in the Department of Police and Public Safety shall be implemented on building doors as follows:
 - Exterior Doors:
 - ◇ All exterior doors (personnel, overhead, access, etc.) shall be equipped with a magnetic position switch, request to exit, electric strike, and be prepared for electronic access control.
 - ◇ The accessible door to the building and any other designated exterior doors shall be equipped with electronic accessible control; a reader, electric strike, magnetic position switch and request to exit.
 - ◇ If this door is the automatic swinging door, then activation of the access control shall cause the door to open automatically.

- Interior Doors:
 - ◇ All interior doors shall be prepared for access control with boxes and conduit for future magnetic position switch, request to exit, electric strike, and reader.
 - ◇ Interior doors designated in the building program or subsequently determined shall be equipped the same as Exterior Doors above. The list of interior doors to be equipped with access control shall be reviewed with the MSU Department of Police and Public Safety.
 - ◇ All interior and exterior Mechanical Room, Electrical Room, and Communication Room doors shall be equipped the same as Exterior Doors above.

EXHIBIT 1: MSU PLANNING PRINCIPLES –Part of Campus Master Plan

EXHIBIT 2: DOCUMENT STANDARDS INFORMATION

INSTRUCTIONS FOR FORMATTING SPECIFICATIONS

Engineering and Architectural Services request all specifications be presented in the same format. Microsoft Word 2010 or newer will be used.

1. Times New Roman 11 Pitch will be used.
2. All margins will be 1".
3. See attached for layout of headers.
4. Please note all Page Nos. should be at the top of the page and within the header.
5. Keep a consistent outline layout with 5 space indents and tabs.
6. Double space between Section Titles and text.
7. Start a new page for each Section.
8. Watch for paragraphs being split due to end of page. If at all possible start new page.
9. Be consistent with bolding, capitalizations, and underlining formats.
10. Show “End of Section” notation.
11. Single side all your work. Double siding will only occur when the document is sent for printing via the Engineering and Architectural Service’s office.
12. If an outside consultant prepares the Specification, please submit a digital copy of the work as well to enable our office to expedite minor corrections.
13. A Footer may be used for Consultant name. Consultant’s project number must be identified as such.

H:/forms/specformat.doc

Building Name – Project Name

TITLE OF SECTION (UPPER CASE)

MSU PROJECT NO. xxxx

PAGE (Section No.) – (Page No. of Section)

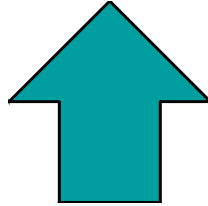

Sample Header

Please use this format for all backend documents.

Consultant's Name

SECTION 16630 - AUDIO-VISUAL EQUIPMENT

PART 1 - GENERAL

1.1 SUMMARY

A. Section Includes

1. Provide all labor, materials, and equipment as necessary to complete all work as indicated on the drawings, and as specified herein.
2. The Contractor shall furnish and install a complete audio-visual system as described herein and as shown on drawings with all necessary components for a complete system.

B. Related Sections:

1. Division 1 - General Requirements
2. Applicable sections of Division 16 - Electrical

1.2 SYSTEM DESCRIPTION

- A. Furnish and install new ceiling mounted speakers, conduit and cable for a complete and functional system.

1.3 SUBMITTAL

1. Shop Drawings

1. Speaker assembly and enclosures.

2.1 PRODUCTS

Speakers shall be Lowell model 8C10W with WB-8H ceiling baffles, 8" speaker with 70V transformers, CP speaker enclosure and Quam SSC-1 support channels. Speaker cable to be West Penn WP 25225B.

End of Section

EXHIBIT 3: MSU BEST PRACTICES LEED

1. Green Checklist

2. Requirements

A. General/Architectural/Furnishings

- Identify materials to be recycled and establish a plan for removal.
- Identify items for Surplus and coordinate with Surplus for removal.
- Provide measurement data and documentation of recycled materials by project.
- Confirm equipment to be used or purchased is energy star rated.
- Include purchase of recycling containers in project budget.
- Include recycled content materials where applicable – Verify with Interior Design the options for recycled content carpet.
- Specify low volatile organic compound (VOC) adhesives and paint.
- Take advantage of day lighting options during design.
- Design to incorporate appropriate spaces for recycling containers.
- Review enhanced security checklist of security needs/card access.
- Evaluate the efficiency of open ceiling plans for laboratories.
- Where applicable use locally manufactured materials including furnishings.
- Review the MSU Green Certification list such that this new space would be MSU Green certified (FUTURE DEVELOPMENT.)
- Future consideration of motion activated paper towel dispenser type and hand dryer.

B. Mechanical – Reduce energy and water consumption

- Low Flow 1/8 gallon urinals for restroom renovations or other spaces that may have a toilet/urinal.
- New installations shall be waterless urinals.
- Include commissioning when major mechanical equipment and/or systems are replaced or installed as new.
- Provide metering capability where appropriate (water and condensate.)
- Provide Heating, Ventilating, Air Conditioning (HVAC) demand capability with override buttons where applicable.
- Provide occupancy sensors for setback on fume hoods where applicable.

C. Electrical – Reduce Energy Consumption

- Provide occupancy sensors for lights where applicable – In particular common areas such as lunch rooms, restrooms, classrooms, etc.
- Provide 2 level switching option for lighting control in all spaces where this type of control is applicable such as conference rooms, classrooms, offices, etc.
- Provide photocell control for lighting where applicable.
- Verify appropriate fixtures and light levels are specified.
- Provide electrical sub-metering where appropriate



EXHIBIT 4: ENERGY IMPACT STATEMENT FORMAT

MICHIGAN STATE UNIVERSITY
INFRASTRUCTURE PLANNING AND FACILITIES
ENGINEERING AND ARCHITECTURAL SERVICES DEPARTMENT

ENERGY IMPACT STATEMENT

Project Name: _____
Gross sq. footage/net sq. footage _____ Gross cubic footage _____

Steam Load

Domestic Hot Water _____ #/Hr.
Space Heating
Air Handling Units _____ #/Hr. Hot Water Heating _____ #Hr.

Fintube, Convectors, Units Heaters, etc. _____ #/Hr.
Absorption Air Conditioning _____ #/Hr.
Process Equipment (Stills, Autoclaves, etc.) _____ #/Hr.
Special Equipment (Itemize Below)
_____ #Hr _____ #/Hr.
_____ #Hr _____ #/Hr.
_____ #Hr _____ #/Hr.
Average Steam Demand _____ #/Hr.
Summer Operation: Maximum Steam Demand _____ #/Hr.
Average Steam Demand _____ #/Hr.
Winter Operation: Maximum Steam Demand _____ #/Hr.
Estimated Yearly Steam Load _____ #/Yr.

Electrical Load

Lights: _____ KW
Equipment:
AC Systems (includes chiller and related pumps, cooling towers, etc.) _____ KW
Air Handling Units _____ KW Special Equipment _____ KW
Misc. Equipment _____ KW
Supplementary Electrical Loads (itemize below):
_____ #Hr _____ #/Hr.
_____ #Hr _____ #/Hr.
_____ #Hr _____ #/Hr.
Winter Average Electrical Demand _____ KW
Summer Average Electrical Demand _____ KW
Maximum Electrical Demand _____ KW
Estimated Yearly Electrical Load _____ KWH/YR

Water

Water Closets_____	GPM	Urinals_____	GPM
Lavatories_____		Lab Sinks and Equip _____	GPM
Cooling Tower/Evap. Condenser Make-Up_____	GPM		
Special Uses (Itemize Below)			
_____	GPM	_____	GPM
_____	GPM	_____	GPM
_____	GPM	_____	GPM
Average Water Demand_____			GPM
Maximum Water Demand_____			GPM
Average Daily Usage_____			GPM
Estimated Yearly Usage_____			GPY

Sewer

Sanitary - Average Daily Usage_____	GPD
Storm - Average Daily Usage_____	GPD

EXHIBIT 5: CAMPUS COMMUNICATION ROOM SIZES

Type of Room

Service

Broadband Utility Room	Broadband service coaxial or fiber to the building will enter in this room; Infrastructure Planning and Facilities domain.
Telephone Utility Room	Telephone service to the building will enter in this room; Infrastructure Planning and Facilities domain.
User Communication Room	Departmentally owned communication and computer equipment used to interface the broadband and/or telephone systems will be located in this room; Department space.

<u>Type of Room</u>	<u>Building Size</u>	<u>Approx. Size of Room</u>
Broadband Utility Room	Any size	12 ft. x 15 f(180sq.ft.)
Telephone Utility Room	0 - 80,000 sq.ft.	9 ft. x 12 ft. (100 sq.ft.)
	80,000 sq.ft.+	12 ft. x 15 ft.
User Communication Room	Any size	(180 sq.ft. or larger as required by the department)

EXHIBIT 6: LODAL PICKUP STATION DESIGN

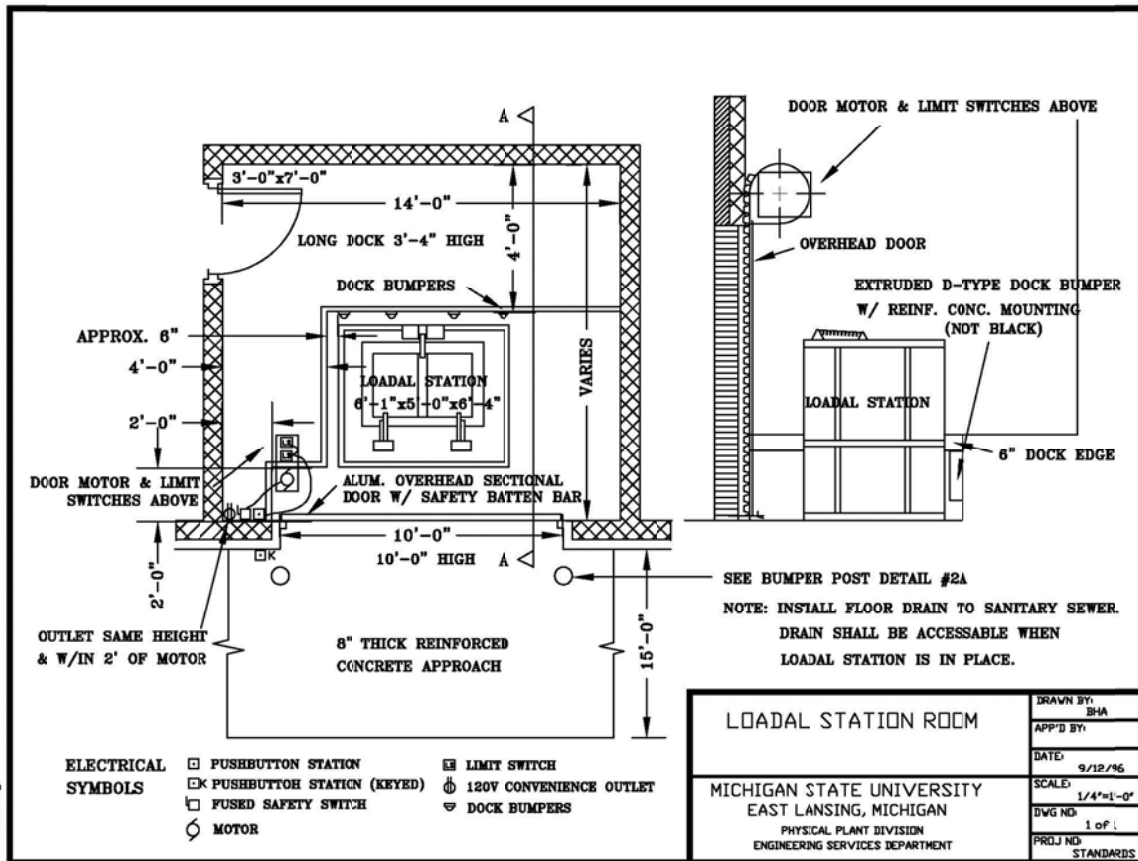

EXHIBIT 7: LEED™ PROJECT CHECKLIST

LEED 2009 for New Construction and Major Renovations		Project Name
Project Checklist		Date
Sustainable Sites Possible Points: 26		Materials and Resources, Continued
<input type="checkbox"/>	Prereq 1 Construction Activity Pollution Prevention	<input type="checkbox"/>
<input checked="" type="checkbox"/>	Credit 1 Site Selection 1	<input type="checkbox"/>
<input type="checkbox"/>	Credit 2 Development Density and Community Connectivity 5	<input type="checkbox"/>
<input type="checkbox"/>	Credit 3 Brownfield Redevelopment 1	<input type="checkbox"/>
<input type="checkbox"/>	Credit 4.1 Alternative Transportation—Public Transportation Access 6	<input type="checkbox"/>
<input type="checkbox"/>	Credit 4.2 Alternative Transportation—Bicycle Storage and Changing Rooms 1	<input type="checkbox"/>
<input type="checkbox"/>	Credit 4.3 Alternative Transportation—Low-Emitting and Fuel-Efficient Vehicles 3	<input type="checkbox"/>
<input type="checkbox"/>	Credit 4.4 Alternative Transportation—Parking Capacity 2	<input type="checkbox"/>
<input type="checkbox"/>	Credit 5.1 Site Development—Protect or Restore Habitat 1	<input type="checkbox"/>
<input type="checkbox"/>	Credit 5.2 Site Development—Maximize Open Space 1	<input type="checkbox"/>
<input type="checkbox"/>	Credit 6.1 Stormwater Design—Quantity Control 1	<input type="checkbox"/>
<input type="checkbox"/>	Credit 6.2 Stormwater Design—Quality Control 1	<input type="checkbox"/>
<input type="checkbox"/>	Credit 7.1 Heat Island Effect—Non-roof 1	<input type="checkbox"/>
<input type="checkbox"/>	Credit 7.2 Heat Island Effect—Roof 1	<input type="checkbox"/>
<input type="checkbox"/>	Credit 8 Light Pollution Reduction 1	<input type="checkbox"/>
<input type="checkbox"/>	Water Efficiency Possible Points: 10	Indoor Environmental Quality Possible Points: 15
<input checked="" type="checkbox"/>	Prereq 1 Water Use Reduction—20% Reduction	<input checked="" type="checkbox"/>
<input type="checkbox"/>	Credit 1 Water Efficient Landscaping 2 to 4	<input type="checkbox"/>
<input type="checkbox"/>	Credit 2 Innovative Wastewater Technologies 2	<input type="checkbox"/>
<input type="checkbox"/>	Credit 3 Water Use Reduction 2 to 4	<input type="checkbox"/>
<input type="checkbox"/>	Energy and Atmosphere Possible Points: 35	<input type="checkbox"/>
<input checked="" type="checkbox"/>	Prereq 1 Fundamental Commissioning of Building Energy Systems	<input type="checkbox"/>
<input checked="" type="checkbox"/>	Prereq 2 Minimum Energy Performance	<input type="checkbox"/>
<input checked="" type="checkbox"/>	Prereq 3 Fundamental Refrigerant Management	<input type="checkbox"/>
<input type="checkbox"/>	Credit 1 Optimize Energy Performance 1 to 19	<input type="checkbox"/>
<input type="checkbox"/>	Credit 2 On-Site Renewable Energy 1 to 7	<input type="checkbox"/>
<input type="checkbox"/>	Credit 3 Enhanced Commissioning 2	<input type="checkbox"/>
<input type="checkbox"/>	Credit 4 Enhanced Refrigerant Management 2	<input type="checkbox"/>
<input type="checkbox"/>	Credit 5 Measurement and Verification 3	<input type="checkbox"/>
<input type="checkbox"/>	Credit 6 Green Power 2	<input type="checkbox"/>
<input type="checkbox"/>	Materials and Resources Possible Points: 14	<input type="checkbox"/>
<input checked="" type="checkbox"/>	Prereq 1 Storage and Collection of Recyclables	<input type="checkbox"/>
<input type="checkbox"/>	Credit 1.1 Building Reuse—Maintain Existing Walls, Floors, and Roof 1 to 3	<input type="checkbox"/>
<input type="checkbox"/>	Credit 1.2 Building Reuse—Maintain 50% of Interior Non-Structural Elements 1	<input type="checkbox"/>
<input type="checkbox"/>	Credit 2 Construction Waste Management 1 to 2	<input type="checkbox"/>
<input type="checkbox"/>	Credit 3 Materials Reuse 1 to 2	<input type="checkbox"/>
<input type="checkbox"/>	Innovation and Design Process Possible Points: 6	<input type="checkbox"/>
<input type="checkbox"/>	Credit 1.1 Innovation in Design: Specific Title 1	<input type="checkbox"/>
<input type="checkbox"/>	Credit 1.2 Innovation in Design: Specific Title 1	<input type="checkbox"/>
<input type="checkbox"/>	Credit 1.3 Innovation in Design: Specific Title 1	<input type="checkbox"/>
<input type="checkbox"/>	Credit 1.4 Innovation in Design: Specific Title 1	<input type="checkbox"/>
<input type="checkbox"/>	Credit 1.5 Innovation in Design: Specific Title 1	<input type="checkbox"/>
<input type="checkbox"/>	Credit 2 LEED Accredited Professional 1	<input type="checkbox"/>
<input type="checkbox"/>	Regional Priority Credits Possible Points: 4	<input type="checkbox"/>
<input type="checkbox"/>	Credit 1.1 Regional Priority: Specific Credit 1	<input type="checkbox"/>
<input type="checkbox"/>	Credit 1.2 Regional Priority: Specific Credit 1	<input type="checkbox"/>
<input type="checkbox"/>	Credit 1.3 Regional Priority: Specific Credit 1	<input type="checkbox"/>
<input type="checkbox"/>	Credit 1.4 Regional Priority: Specific Credit 1	<input type="checkbox"/>
<input type="checkbox"/>	Total Possible Points: 110	<input type="checkbox"/>

Certified 40 to 49 points Silver 50 to 59 points Gold 60 to 79 points Platinum 80 to 110

	PAGE
<u>TABLE OF CONTENTS</u>	<u>1</u>
<u>ARCHITECTURAL DESIGN</u>	<u>14</u>
SUSTAINABILITY	
Building Orientation	
Building Style	
Hazardous Materials	
Structure	
Minimum Design Values	
Rodent and Insect Proofing	

ARCHITECTURAL DESIGN

1. SUSTAINABILITY

- A. The performance standard, LEED™ v3, shall be implemented to the extent feasible and practicable in all new buildings and major renovations in existing buildings. Refer to LEED™ in Design Guidelines – General Section for more information.

2. BUILDING ORIENTATION

- A. The building should be oriented on the site in a manner that will reduce the effect of winter winds on heating, summer sun on cooling, and infiltration of winter winds at entrances. Use compact building shapes to minimize the surfaces exposed to exterior heat or cold.
- B. A main entrance will be oriented toward a bus stop and accessible parking. Unless directed otherwise, the means of access to this entrance will have automatically controlled heated sidewalks to maintain access during snow and ice storms.

3. BUILDING STYLE

- A. M.S.U. desires new buildings to be distinctively designed and complementary to the existing campus. Alterations to the exterior of existing buildings shall match the existing building and additions to existing buildings shall match or at least harmonize with the existing building unless directed otherwise. Brick and limestone are the predominant exterior building materials.

4. HAZARDOUS MATERIALS:

- A. On every project involving existing facilities the design professional shall check for the existence of asbestos, lead paint, heavy metals, toxic substances, and other regulated hazardous materials, and incorporate strategies acceptable to the University into the project documents. Some buildings and portions of buildings have been inspected for asbestos containing materials and lead based paint. Available records of asbestos building inspections and lead based paint testing can be requested from the Office of Environmental Health and Safety (EHS). Contact with EHS should be made through the M.S.U. Project Design Representative.
- B. To avoid problems that may result from the use of asbestos building inspections for renovation demolition projects a type II inspection may be needed. A type II inspection is used to identify material that could be hidden behind walls and above solid ceilings and to sample materials that are excluded from testing or were assumed to contain asbestos in the initial inspection.
- C. Asbestos Containing Materials(ACM) that are determined to be regulated asbestos containing materials (RACM) as defined by 40 CFR 61 NESHAP will need to be removed if they have the potential to be disturbed during the renovation or demolition. The policy for removal of ACM/RACM from existing buildings shall be as follows:
 - Remove any ACM/RACM that must be disturbed as part of the construction. If the existing ACM/RACM occurs on a pipe that only needs to have a tap for a branch run, valve or fitting, remove only that portion of the ACM required to effect the tie in. This removal must include the removal of adjacent material and the proper encapsulation of

- exposed material to ensure that mechanical workers are not exposed and will not damage remaining material.
- Remove ACM/RACM in the work area that is friable or shows signs of damage or deterioration.
 - All dust and debris in a work area that is associated with ACM shall be cleaned up prior to the initiation of a renovation demolition in the same general area.
 - Remove all ACM that has a reasonable potential for becoming damaged either during or after the construction process.
- D. Removal procedures shall comply with the latest local, state and federal rules, codes and/or regulations relative to asbestos removal and disposal.
- Removal shall be conducted by a state of Michigan licensed abatement contractor utilizing state accredited asbestos supervisors and workers.
 - Removal of friable asbestos containing material in quantities greater than 260 linear feet or 160 square feet in the same room shall be conducted in a full negative pressure enclosure. The glove bag procedure may be used at or above these quantities only with the written approval of the Office of Environmental Health and Safety.
 - Air monitoring and project oversight shall be provided by an independent neutral third party that will represent the interest of MSU and or the general contractor on all projects that remove friable material greater than 10 linear feet or 15 square feet. If the renovation/demolition project is managed by a general contractor they will be required to retain the “consulting” air monitoring firm. If the project is directly managed by MSU, MSU shall retain the services of the air monitoring firm.
 - Clearance samples shall be collected on all projects that include the removal of friable material and on projects removing greater than 10 linear feet or 15 square feet of non-friable material.
 - A copy of all reports generated for inspection or asbestos abatement will be supplied to the Office of Environmental Health and Safety.
- E. On projects involving new facilities, the design professional shall coordinate with the facility/building manager and EHS to identify the maximum expected quantities of compressed gas and cryogenic fluids to be used or stored, and to indicate the methods of protection from such hazards in the report and on the construction documents. Complete code trail, ventilation control analysis and hazard evaluation shall be reviewed by MSU Fire Marshall, EAS and EHS; and be included in the report.
5. STRUCTURE
- A. The preferred structural system is poured-in-place reinforced concrete. Other systems will be considered if detailed cost comparisons are made.
 - B. Ferrous metals will be avoided on the exterior of buildings. All necessary exterior steel and interior steel in damp or humid locations will be hot-dipped galvanized after fabrication, e.g. exterior window lintels, cooling tower support framing, etc.
 - C. Structural drawings shall indicate in tabular form the soil pressure used for footing design and design loads used in designing floors, roofs, stairs, etc.

6. **MINIMUM DESIGN VALUES:** Minimum design values will be in accordance with the most current edition of the Michigan Building Code except as follows, or as more stringent parameters would dictate.
- A. Roofs: 35 lb./sq.ft. live snow load plus allowances for drifting. Analyze lower projecting canopies carefully. Wind up-lift on any roof will be analyzed with 90 mph. wind.
 - B. Exterior Walls: 20 lb./sq.ft. wind load plus allowances for effects of any unusual shapes.
 - C. Floors: Minimum live loads are as follows, but consideration must be given to possible space change alterations and actual design condition:
 - Classrooms and Laboratories 100 lb./sq.ft.
 - Offices 80 lb./sq.ft.
 - D. Provide structural isolation of large compressor equipment or other vibrating equipment not located on the basement floor of the building.
 - E. The entrance and slab outside all entrance doors will be supported on all sides by the building foundation with insulation or drainage to prevent frost heaving action. The sidewalk will be keyed to this approach slab.
 - F. To eliminate the possibility of concrete slabs settling next to buildings or structures, all concrete pavement (i.e. walks, driveways, etc.) adjacent to structures (i.e. buildings, planters) that have a frost-free footing, shall be placed over a concrete haunch that is an integral part of the structure. The haunch shall be not less than 6" wide and extend the width of the pavement.
 - G. The vestibule of main entrances for academic buildings should have a non-corrosive grating with 1/2" slots over a waterproof stainless steel pan with a trap. Provide an indoor hose bib for cleaning. Light traffic and residence hall entrances shall have flush hard tile or terrazzo with surface mats.

7. **BUILDING ENVELOPE**

- A. Energy Performance:
 - Energy Analysis Computer Programs: Building energy requirements are best analyzed through the use of computer programs which simulate weather conditions, building occupancy, and systems operation over a typical year. All proposed facilities should run a comparative analysis of project options using an energy analysis program. The input and output data from these computer programs will be provided to Engineering Services for review.
 - An energy impact statement is to be completed and returned to the owner. A sample format is located at the back of this division.
 - ASHRAE 90, current edition, shall be followed as a minimum for energy conservation in buildings design. Where these Construction Standards call for a more stringent design requirement, the Construction Standards shall be followed.
- B. Exterior Finishes:
 - No material or products requiring painting shall be used on the exterior of a building. No special brick shapes shall be used in or on the building.
- C. Exterior Walls:

- Cavity masonry walls will have extruded polystyrene insulation with a minimum five year aged R Value of 12. Below grade masonry walls will have polystyrene insulation with a minimum five-year aged R Value of 5.
- Stud walls will have a minimum of R-19 fiberglass batt insulation. Exterior walls will have a vapor/infiltration barrier. Vapor retarder will have a maximum permeance rating of 0.13 perm.
- Minimize the use of freestanding brick walls. Brick fin-walls, fences, vision screens, tall parapet walls, etc., are subject to extreme and excessive freeze-thaw cycling with no heat to dry-out. If such walls are required, provide ample expansion control and through wall flashing under a capstone.

D. Roofs

- Roofs and rain conductors will be designed for a rain fall intensity of 6" per 5 minute period, and 2-1/2" per 60 minute period applied separately.
- Flat roofs are generally acceptable and are typically the protected membrane type. A minimum slope of 1/4:12 should be provided. Alterations within the field of an existing conventional built-up roof will match the existing conventional roof construction, but where a break can be made, the new roof will be the protected membrane type.
- All main roof areas will be accessible by stairway roof hatch or doorway from a penthouse. Small secondary roof areas will be accessible from the main roof by way of permanent fixed ladders. Roofs that cannot be accessed by maintenance personnel, without carrying ladders, will be avoided.
- Scuppers and exterior drains will not be used including on canopies and other small flat roofs. Place drains within 3 ft. of heated part of building, (but not in the base flashings), and insulate conductor to inside of building.

E. Entrances:

- Public Entrances
 - ◇ All main entrances will be designed with a vestibule, a canopy or a sheltered recess to minimize infiltration and to protect the entrance from the weather and to reduce the use of deicing chemicals. The main entrance doors nearest the accessible parking and the bus stop will be automated. (See SECTION 084229 – AUTOMATIC ENTRANCES). The main entrance lobby shall include barrier-free toilet rooms, telephones (public and campus), dual level drinking fountain, and elevator.
 - ◇ All other barrier-free public entrances and vestibules which are not automated will each have a 36" clear wall space on the latch side of the door and flush with the door to facilitate accessible access, especially wheelchair user access to the doors.
 - ◇ A building directory will be installed at the main building entrance. Where other entrances are major entrances, additional directories will be installed. Directories shall be changeable letter type with a hinged door. The door shall have a concealed continuous piano hinge and use a Corbin cabinet lock. Acceptable manufacturers: Davsar or A.L. Davenport & Son, Co. or equal.
 - ◇ Entrance recesses will be wide enough to allow doors to swing free for a minimum of 120 deg. before contacting a doorstep to minimize shock on door, frame, and hardware.
 - ◇ The entrance and slab outside of all entrance doors will be supported on all sides by the building foundation with insulation or drainage to prevent frost heaving action. The sidewalk will be keyed to this approach slab.

- ◇ To eliminate the possibility of concrete slabs settling next to buildings or structures, all concrete pavement (e.g. walks, driveways, etc.) adjacent to structures (e.g. buildings, planters) that have a frost-free footing, shall be placed over a concrete haunch that is an integral part of the structure. The haunch shall not be less than 6" wide and extend the width of the pavement.
 - ◇ The vestibule of main entrances for academic buildings should have a non-corrosive grating with 1/2" slots over a waterproof stainless steel pan with a trap. Provide an indoor hose bib for cleaning. Light traffic and residence hall entrances shall have flush hard tile or terrazzo with surface mats.
 - Service Entrances
 - ◇ All main service entrances will be designed with a loading dock, a canopy, and a sheltered recess to protect the entrance from weather and to reduce the use of deicing chemicals. Overhangs will provide 14 ft. clearance above grade for trucks. Loading docks will be accessible from grade by stairs and handrails, not ladders. Doors will be flush swinging or sectional overhead (See Construction Standards Section 083613 – Sectional Doors). Do not use coiling doors because they have poor resistance to impact and thermal and infiltration performance is less than that of sectional doors.
 - ◇ With new building construction, there may be a need to provide a Grounds Maintenance Substation to house personnel and equipment, with direct access to a drive or parking area. Contact MSU EAS project manager for specific requirements.
8. **RODENT AND INSECT PROOFING:** All openings into the buildings shall be rodent and insect proof. Basement windows and other openings, which might provide access, will be provided with double strength screening or regular screening and hardware cloth.

	PAGE
<u>TABLE OF CONTENTS</u>	<u>1</u>
<u>MECHANICAL</u>	<u>2</u>
Summary	
Design Process	
Sustainability	
Occupant Comfort	
Load Calculations	
HVAC	
Refrigeration	
Controls	
Plumbing	
Fire Protection	
Access for Maintenance and Repair	

MECHANICAL DESIGN

1. SUMMARY

- A. This section contains information which serves as general requirements for mechanical design.
- B. Refer to applicable codes and standards for further information on the criteria mentioned in this section. Where codes and standards are contradictory, follow the most stringent requirements.
- C. Refer to Section of this document for mechanical space requirements and to appropriate sections of Division 15 of the Construction Standards for additional design considerations.
- D. References:
 - Americans with Disabilities Act (ADA), Public Law 101-336
 - ANSI/AIHA Z9.5, Laboratory Ventilation
 - ASHRAE Standard 15, Safety Standard for Refrigeration Systems
 - ASHRAE Standard 55, Thermal Comfort for Human Occupancy
 - ASHRAE Standard 62.1, Ventilation for Acceptable Indoor Air Quality
 - ASHRAE Standard 90.1, Energy Standard for Buildings Except Low-Rise Residential Buildings
 - Institute of Laboratory Animal Resource (ILAR)
 - Leadership in Energy & Environmental Design (LEED™) v3 for New Construction and Major Renovations
 - Michigan Boiler Code
 - Michigan Mechanical Code (MMC)
 - Michigan Plumbing Code (MPC)
 - Michigan Uniform Energy Code
 - Michigan Fire Safety Rules
 - Michigan Barrier Free Design
 - NFPA 13, Standard for the Installation of Sprinkler Systems
 - NFPA 14, Standard for the Installation of Standpipe, Private Hydrant, and Hoses Systems
 - NFPA 20, Standard for the Installation of Stationary Pumps for Fire Protection
 - NFPA 45, Standard on Fire Protection for Laboratories Using Chemicals
 - NFPA 90A, Standard for the Installation of Air Conditioning and Ventilating Systems
 - NFPA 101, Life Safety Code
 - Sheet Metal and Air Conditioning National Contractors Association (SMACNA)

2. DESIGN PROCESS

- A. General: The design process for major projects includes all phases as indicated below. The requirements as described herein are typical, and may vary. Consult with MSU Infrastructure Planning and Facilities (IPF) / Engineering and Architectural Services (EAS).
- B. Program Phase: Include environmental program containing design indoor and outdoor conditions, heating and cooling degree-hours, applicable codes, etc. This phase is typically not required for purchase order projects.

- C. Schematic Design Phase: Include environmental program containing design indoor and outdoor conditions, heating and cooling degree-hours, applicable codes, etc. This phase is typically not required for purchase order projects:
- Code analysis and design criteria
 - System descriptions
 - Energy code compliance
 - Relative space requirement for equipment, ducts, and piping
 - Energy impact statement
 - Cost model
 - Schedule
 - Drawings including typical layouts and schematic diagrams
 - Specification outline
- D. Design Development Phase: Include system layouts for space requirements, revised cost estimates, and revised schedule. This phase is typically not required for purchase order projects.
- E. Contract Document Phase: Complete specification and drawings including typical details, schematic diagrams, drainage/waste/vent riser diagrams, water riser diagrams, and control diagrams. Riser diagrams are not required for minor additions, alterations and renovations.
- F. Construction Phase: Include shop drawing review, and periodic visits to the building under construction. This phase is optional for formal projects, and typically not required for purchase order projects.
- G. Commissioning Phase: Include functional tests of all building systems.
- H. Post-occupancy Services Phase: Include assistance to MSU Facilities Planning and Facilities personnel in operating it for a period of at least six months after completion. This phase is optional. It may include adjustments and modifications to the HVAC systems.
3. SUSTAINABILITY
- A. The performance standard, LEED™ v3, shall be implemented to the extent feasible and practicable in all new buildings and major renovations in existing buildings. Refer to LEED™ in Design Guidelines – General Section for more information.
4. OCCUPANT COMFORT
- A. Thermal Comfort
- Indoor temperature and humidity conditions must be in accordance with the comfort criteria established in ASHRAE 55.
 - Winter humidification and summer dehumidification are not typically required. When winter humidification is provided for comfort, a minimum relative humidity of 30% is generally acceptable.
 - Relative humidity for special areas such as computer rooms, research laboratories, etc., must not exceed 50%.

B. Ventilation

- Offices, Classrooms, Auditoriums, etc.: Refer to ASHRAE 62.1
- Teaching and Research Laboratories: Refer to NFPA 45 and ANSI Z9.5. Minimum ventilation rate must be 6 air changes per hour when occupied.
- Animal Facilities: Refer to Institute of Laboratory Animal Resource (ILAR).

C. Noise and Vibration

- Refer to ASHRAE Handbook – HVAC Applications for recommended Room Criterion (RC). Noise Criterion (NC) may be substituted if the quality of the sound in the space is of secondary concern.

5. LOAD CALCULATIONS

A. Outdoor Design Conditions: Refer to ASHRAE Handbook – Fundamentals and ASHRAE 90.1

- Non-critical Applications:
 - ◇ Heating @ 99.6%: -3° F DB
 - ◇ Cooling @ 1%: 86/72° F DB/MCWB
- Critical Applications:
 - ◇ Heating: -10° F DB
 - ◇ Cooling @ 0.4%: 89/74° F DB/MCWB
- Evaporative Cooling: 78° F WB

B. Indoor Design Conditions: Occupied spaces, unless noted otherwise, shall be designed to maintain the following temperature and humidity levels:

- Comfort Applications
 - ◇ Temperature: 75°F DB for cooling, 70°F DB for heating
 - ◇ Relative Humidity: 30 – 60%
- Process Applications:
 - ◇ Temperature: 72° ± 2° F DB
 - ◇ Relative Humidity 50% ± 5%

6. HVAC

A. Zoning Consideration

- Central heating and cooling systems must be used whenever practical since they are much more efficient than individual or package units.
- Zones with substantially differing load characteristics must be served by separate air distribution systems.
- Spaces which might require operation 24 hours a day must be served by HVAC systems separate from systems for offices, which might require operation for only 8 hours a day, and classrooms, which might be shut down during summer.

- Individual air conditioning units, fan coil units, and/or radiation must be provided in specific areas such as communication rooms, perimeter spaces, etc., to facilitate shut down of main HVAC units.

B. Heating Systems

- Heating is usually accomplished through hot water perimeter systems using steam converters.
- Reheat shall not be used in any constant volume HVAC system.
- HVAC systems which require reheat for temperature or humidity control should utilize recovered heat for the reheat function.
- Systems that blend refrigerated air and heated air for temperature control should not be used unless recovered energy is used for reheat.
- Air handlers will normally be equipped with heating coils using steam as the heating medium. Steam coils are less susceptible to freeze-up than hot water coils. Vacuum breakers must be installed in the top of the steam supply headers, after the automatic control valves. All steam coils must be protected with automatic low limit control to shut off the fan to protect the coil from freezing.
- In general, heat exchangers used as convertors for comfort heating must be of duplex or triplex type. Each convertor of duplex system must be sized for a 100% capacity. Each convertor of triplex system must be sized for a 50% capacity. Each convertor must be provided with parallel valves sized for 1/3 and 2/3 of its capacity.
- The use of ceiling radiant heating system is acceptable. However, use of finned-tube radiation for perimeter heating is preferred.
- Do not provide bypass line around steam traps, control valves, and PRVs.
- Discharge high-pressure condensate in a building to a low pressure system through flash tank or vented receiver of a pressure powered pump condensate recovery unit. Do not discharge condensate from varying pressures into a common return line or directly into a condensate pump discharge line.
- Steam Systems
 - ◇ Operating pressures of the LP steam in existing building vary from 7 to 15 psig.
 - ◇ Operating pressures of the LP steam in new construction should be designed for 15 psig.
 - ◇ The set pressures of the safety valves should be 5 psi higher than the PRV reduced pressures.
 - ◇ LP drip traps should be selected for maximum operating pressure not less than relief valve set pressure.
 - ◇ Valves, strainers and fittings in HP shall be rated not less than 150 psi working pressure.
 - ◇ HP drip traps shall be selected for maximum operating pressure not less than 150 psi working pressure
 - ◇ Steam traps on coils, heat exchangers, water heaters, e.g., should be selected for maximum operating pressure not less than the control valve inlet pressure.
 - ◇ Steam control valves should be selected for min. close off pressure not less than the control valve inlet pressure.
- Steam Heating Coils

- ◇ Standard steam distributing coils are suitable for applications involving little or no outside air heating requirement, where mixed air temperatures are assured to be above 40 degree F.
- ◇ Integral face and by-pass steam heating coils must be used for all applications where large percentages of outside air are to be heated (mixed air temperature is below 40 degree F). Their non-freeze characteristics insure their continued reliability.
- ◇ Provide adequate spacing between face and bypass steam heating coil and cooling coil to assure proper mixing of heated and bypassed air to prevent nuisance of tripping low limit control.

C. Ventilation Systems

- Radioisotope hood exhaust system must be independent of other building exhaust system. Provision should be made for filters to be installed at hood outlet if required, and fan should be selected for recommended filter final resistance.
- Perchloric exhaust system must be dedicated to each BSC unit and independent of other building exhaust system. Horizontal run must be avoided.
- Bio-safety cabinet exhaust system must be dedicated to each BSC unit and independent of other building exhaust system. Fans must be selected for recommended filter final resistance.
- Diversity factor of not less than 75% of maximum ventilation requirement for manifolded exhaust systems can be applied at system level, not at room level.

D. Air Conditioning Systems

- Air-side economizer cycle must be used in all air handling systems to provide full cooling without the use of mechanical refrigeration whenever the outside temperature is lower than the required supply temperature.
- Air system may be designed for high or low velocity. The chief justification for high duct velocity is space limitation. Return air ducts should be sized for low velocities. Hung ceilings for return plenums may be used.
- For occupant comfort, the supply air should not be more than 20°F. colder than the room temperature.
- Reheat coils should be provided at the VAV terminals for both interior and perimeter spaces.
- Dual duct systems are not preferred because of their high energy consumption.
- The use of window air conditioners is not encouraged. Split systems or central air conditioning systems should be considered.
- Provide twist timers and/or low ambient lockout devices for all air conditioners to prohibit the units from operating when the space is unoccupied and/or at low outdoor air temperatures.
- Air conditioning system larger than 20 tons or requiring more than 20% outside air must be of chilled water type. DX cooling is not acceptable.
- Small capacity water-cooled air conditioning units may be used for unoccupied equipment rooms requiring continuous year-round cooling under the following conditions:
 - ◇ Flat roof is not available for installation of an air-cooled condenser or condensing unit.

- ◇ Installation is cost prohibitive due to the distance between the room being air conditioned and the nearest available roof.
- ◇ Cooling system capacity does not exceed 2 ½ tons, to limit the amount of water usage.

E. Air Distribution

- Do not use ducts or plenums of masonry construction.
- Do not use ceiling air plenum supply systems.
- Pay particular attention to the fan style selection and ductwork arrangement at fan inlets and outlets to minimize pressure losses.
- Do not install ductwork through dedicated electrical rooms or spaces unless the ductwork is serving these areas.
- Specify duct pressure class in accordance with SMACNA pressure classification equal to 150% of calculated static pressure for the section. Note that this is not the static pressure at which the fan is scheduled.
- Duct liner shall not be installed in ductwork to avoid contamination from fiberglass duct lining. Sound attenuators may be used to ensure a quiet installation.

F. Air Handling Units

- The use of package roof top air handling units is not encouraged due to the difficulty of maintaining such units.
- Modular air handling units are generally used where sizes permit their selection. Access module must be provided between heating coil and cooling coil. When using plug fan module, a medium blank module should be provided between the coil and the fan for proper air distribution.

G. Fans

- Specify centrifugal fans for all applications. Do not use in-line adjustable vane axial fans. They exhibit unsatisfactory operating characteristics.
- Inlet vane control is an acceptable means of regulating fan output. However, VFD is a preferred method.
- Floor-mounted fans are strongly preferred. In-line centrifugal fans will be allowed on retrofit projects where lack of floor space is a factor, provided the fans are accessible for maintenance. Provide easy access for inspection, cleaning, service and removal of internal fan components for all in-line fans.
- Do not locate general and toilet exhaust fans on roof. Locate fans inside the penthouse mechanical rooms. If exhaust fan is on roof, must use direct drive ECM motor.
- Locate fume hood exhaust fans outside the building or in a separate mechanical room that is maintained under slight negative pressure with respect to adjacent spaces. Do not locate these fans in the same mechanical room that houses the AHUs and other equipment.
- Fan motors should be selected to operate against the filter final resistance.
- Size the supply fan to handle the static pressure requirements of the higher of either 100% economizer operation or maximum return air operation.

H. Hydronic Systems

- Piping systems must be designed for a friction loss rate no greater than 4.0 ft. of water per 100 equivalent feet of pipe.
- Primary/secondary pumping designs are highly recommended for systems with large high pressure drop distribution systems.

I. Snow-melting Systems

- Heated sidewalks over or near underground utilities must be avoided. Deviations must be reviewed with MSU IPF.
- No permanent connection should be installed between the snow-melting system and domestic water supply.

J. Chemical Water Treatment

- Provide shot type feeders and make up water lines on closed circuit hot water heating and chilled water systems without glycol.
- For chilled water or snow melt system with glycol, provide feed line with hose bib connection with valve at 4' AFF. Clearly label glycol feed line near hose connection. Shot feeders, make-up water lines, glycol storage tanks, make-up pumps, and low water level controllers are not needed.
- Provide automatic chemical feed systems for condenser water systems.
- Fill chilled water circuits of all exterior mounted chillers and/or chillers required to be operated in cold weather with a minimum 30% solution of ethylene glycol.
- Locate tanks where chemicals can be easily transported, and within 20' of the injection point. Provide water proofed, chemical resistance coated, depressed containment which is flush with floor and covered with grating on top. Consult with MSU IPF for sizing details.
- Chemical treatment stations must be adequately lighted and ventilated. An eyewash, safety shower, and hose bib shall be provided in the treatment area.
- Install emergency shower and eyewash equipment in accessible locations within 100 feet from the chemical treatment stations.
- A plumbed emergency shower and/or eyewash shall be installed near the glycol stations in new facilities.
- Self-contained eyewash equipment (i.e., portable units), may be used at the glycol solution feed stations provided the following criteria are met:
- It is not feasible to install a plumbed emergency shower and/or eyewash in renovation projects.
- Self-contained eyewash equipment meets the American National Standards for Emergency Eyewash and Shower Equipment (i.e., ANSI Z358).
- Self-contained eyewash equipment is accessible.
- Self-contained eyewash equipment shall be maintained per the manufacturer's instruction.
- The appropriate PPE shall be maintained and worn properly when working with the glycol material.
- Wherever possible, an accessible emergency shower and/or eyewash shall be installed near the glycol material in their current locations.

7. REFRIGERATION

A. General

- Use zero CFC-based refrigerants. Minimize the use of HCFCs.
- Air-cooled refrigeration equipment must be utilized wherever possible. Unless otherwise noted, no water-cooled refrigeration equipment utilizing domestic water is installed at MSU, including department owned laboratory apparatus which will waste a significant quantity of cooling water. Closed circuit condenser water systems, delivering 85° F. water, must be installed for water-cooled equipment. If certain equipment requires colder water, closed circuit process chillers must be installed.
- A 125 volt, single phase, 15A receptacle outlet must be installed at an accessible location for the servicing of refrigeration equipment on rooftops and in attics and crawl spaces. The receptacle must be located on the same level and within 25 ft of the equipment. The receptacle outlet must not be connected to the load side of the equipment disconnecting means.
- Source of potable hose bibs must be provided nearby for all outdoor 10 ton and larger condensing/condenser units and cooling towers.

B. Condensers

- Propeller fan style air-cooled condensers are normally installed outdoors. If job conditions prohibit such installation, centrifugal fan style condensers may be installed indoors in mechanical spaces.
- Means must be provided to clean the finned surfaces of condenser coils. Outdoors, a source of potable water should be provided nearby (hose bib). Indoors, the condenser should be provided with 50% efficient bag style air filters to keep the coil clean. If space conditions prohibit the air filters a source of potable water must be provided, with a drain pan under the entire condenser and the hose bib area to contain the waste water and pipe it to drain.

C. Water Chillers

- Select electric screw chillers for applications in 400 tons or less. Select single-stage absorption chillers for applications larger than 400 tons. For applications in larger than 1200 tons range, two-stage absorption chillers should be considered due to significant savings in operating cost.
- Where loads exceed 500 tons and/or where great reliability is required, two equal sized units of the same model should be used. These units are generally piped parallel and have separate chilled and condenser water pumps with cross connected piping so one unit may operate alone. Control of units must be fully automatic with start-up initiated by an outside air temperature thermostat.
- Steam fired absorption chillers produce very hot steam condensate, requiring special condensate pumps such as steam pressure powered pump. Condensate receivers must be vented to outdoors.

D. Cooling Towers

- Process water requires year-round tower operation and reasonable water temperature control. Packaged centrifugal blower type towers have been used in this application, mounted indoors with control of inlet and discharge air through dampers. Process water cooling towers must be extremely reliable. Duplex pumps, each sized for 100% load,

should be installed with isolation valves to allow pump repair without system shutdown. Split fan drive systems with two motors, and cold water make-up sufficient to carry partial load temporarily should be considered.

- Indoor cooling towers must be applied and installed in such a manner so as not to cause a maintenance problem due to condensation on or around the unit. Provide separate air intake and discharge ductwork for the tower, not in common with building HVAC systems. Outside air intake dampers must be mounted where tower water will not wet air intake damper. This will prevent freezing of damper position. Dampers must be constructed of non-corroding materials.
- Adequate cooling towers must be applied and installed in such a manner so as not to cause a maintenance problem due to condensation on or around the unit. Provide separate air intake and discharge ductwork for the tower, not in common with building HVAC systems. Outside air intake dampers must be mounted where tower water will not wet air intake damper. This will prevent freezing of damper position. Dampers must be constructed of non-corroding materials.
- Cooling towers must be located at such distance and direction to avoid the possibility of contaminated tower discharge air being drawn into building fresh air intakes.
- Architectural enclosures for aesthetic reasons should be considered for roof-mounted cooling towers.
- Provide variable speed drives in lieu of bypass lines on cooling towers for the absorption chillers. Locate sensing devices near tower outlet.

E. Walk-in Freezers and Coolers

- Condensing units for walk-in freezers and coolers must be installed in central location in the refrigeration/mechanical room and on floor mounted racks, not on top of the freezers/coolers. Air-cooled system is preferred. Provide electric defrost for unit coolers/freezers

8. CONTROLS

A. General

- All new buildings at MSU are to be connected to existing Central Energy Management System and must have temperature control systems of the “Direct Digital” type. Remodel projects in present buildings must extend the existing control systems in that building, whether pneumatic or EMS. Remodel projects that add a significant amount of new mechanical systems, such as chillers, air handlers, and converters, shall have temperature control systems of the “Direct Digital” type. Electric actuation is preferred. Pneumatic may be used in existing facilities or retrofits where appropriate. Consult with EAS prior to using pneumatic actuation.
- Pneumatic controls may be used in alteration projects in existing buildings with pneumatic control system. DDC must be considered for new mechanical systems. Consult with MSU IPF / EAS.
- Wireless controls may be considered for non-critical areas as approved by owner. All safety related controls must be hardwired.

B. Shutdown Controls

- All nonessential fans must be shut off during unoccupied hours. On systems where the ventilating unit is the only source of heat, low limit zone thermostats should override the time clock to maintain minimum building temperatures.
- Start and stop water chillers according to outdoor air temperatures. Necessary sensors must be installed to provide enthalpy control for building chillers.

C. Setback Controls

- Day Un-occupied Mode: 78°F DB for cooling, 68°F DB for heating.
- Night Mode: Cooling system off, 55°F DB for heating.

D. Economizer Controls

- The intake of outside air should be minimized except when it can be utilized for cooling purposes. In areas where large amounts of outside air are required for limited periods of time such as anatomy labs, lecture rooms, etc., provide occupant control of outside air. This can usually be accomplished with an interval timer which will return the system to minimum outside air after a fixed period of time.

E. Ventilation Controls

- For VAV systems, air flow measuring devices should be provided to measure outdoor airflow at the air handler and maintain outdoor airflow over the entire supply airflow operating range.

F. Zone Controls

- The control system should be sequenced to prevent simultaneous heating and cooling.
- Ventilating unit discharge temperatures should be reset as controlled by zone demand. This can be accomplished with room thermostats and load analyzers.

G. Heating Hot Water Controls

- For constant air volume and/or perimeter heating only systems, reset heating hot water convertors and start and stop circulation pumps according to outdoor air temperatures.

9. PLUMBING

A. Barrier Free Design

- Americans with Disabilities Act (ADA), Public Law 101-336 must be followed as the standard in the design of accessible features in new construction and alterations.
- Design must also be reviewed for compliance with the State of Michigan Barrier Free Design requirements. When there is a conflict, ADA must govern. When a Michigan requirement exists and ADA does not, the Michigan code must apply.
- Remodeling work must also comply with the rules as near as possible. Deviations must be reviewed with the MSU University Engineer.

- Toilet Stalls - Requires the 60 inch standard stall in new construction with the alternate stalls being allowed in existing. In large toilet rooms where six or more toilets stalls are provided, a 36 inch wide stall with parallel grab bars must be provided in addition to the standard stall required in new construction. If the 36 inch stall can be worked into the space of the existing toilet room, it should be included in the project.
- Water Coolers - Wherever possible, replace the existing drinking fountains with the new dual height unit. If there is not room for dual unit, set the new fountain at the lower Handicap Height. In larger buildings, follow the code with the 50/50 split

B. Water Supply and Distribution Systems

- When conditions are such that University system water pressure will not be sufficient for outlet requirements, a water pressure booster station must be provided. Special attention must be given to penthouse equipment, such as stills, cooling tower make-up, etc., and also to flush valve operation at top floors of four story and taller structures.
- Main shut off valves must be provided to allow isolation of entire rest room from the rest of the building.
- Isolation valves must be conveniently located on branch lines so that segments can be taken off line quickly in the advent of failures.

C. Water Softening

- In general, water softeners must be provided in individual buildings for hot water heaters and must be considered for condensing equipment and equipment such as stills, etc. Office type buildings with low hot water usage need not have softeners. Residence halls must have three softeners with two in service at all times. Normally both softeners are in service at once and are sized for regeneration about every 24 to 36 hours.
- Water softeners must be provided for both cold and hot water systems of buildings located on the South side of Mt Hope Road which have very hard well water.

D. Sanitary Drainage Systems

- Chemical waste system must be installed and designed as an independent sanitary drainage system. Consult with MSU Environmental Health & Safety (EHS) regarding the interconnection between the building sanitary drainage and chemical waste systems.
- Building sanitary drain must discharge by gravity to the sanitary sewer. Avoid having water closets connected to building subdrain if the building subdrain does not drain by gravity into the sewer system.
- Indirect waste receptors shall not be installed above ceilings or in any inaccessible, concealed or unventilated area. If possible, these drains will be run to an area frequently used such as custodial closet.

E. Storm Drainage Systems: Secondary roof drainage must be completely independent of the primary roof drainage system.

F. Emergency Showers

- In areas where whole body wetting is not required a hand operated hose spray may be used. This should have a quick opening squeeze lever valve with a flow of at least six gallons per minute in a spray pattern. This spray may be located near the laboratory sink.

- Floor drains must be provided with emergency showers.
- Provide 60-95° F. water at the equipment. Refer to ANSI 358.1 for flow requirements.
- Provide audible alarms or blinking lights to units in remote areas to indicate that the unit is in operation. Alarms are to be local, on electrical power rather than battery, and not on the emergency power system.
- Consult with MSU EHS for emergency shower locations.

G. Elevator Equipment Room

- Drains connected directly to sewers shall not be installed in elevators pits.
- Where drains are not provided in new or renovated elevator pit with a sprinkler head in it, sump pump shall be provided. Cover sump in pits. Level the cover with the pit floor. Install check valve on pump discharge as close to the pump as possible. Discharge through an air gap into a waste receptor. Size the pump large enough to handle at least the flow of a sprinkler head in the pit.

10. FIRE PROTECTION

A. Wet Pipe Sprinkler Systems

- Automatic sprinklers must be installed throughout all major buildings.
- A sprinkler system with more than 20 heads must have an outside fire department connection placed near the loading dock, located between 18" and 48" above ground level. Reduced pressure type backflow preventers must be installed in the sprinkler systems having fire department connections.
- When a portion of systems are subject to freezing, sprinklers must be installed as a dry-pipe system except for small unheated areas requiring less than 40 gallons. Antifreeze system must be used. Antifreeze solution must be propylene glycol. Reduced pressure type backflow preventer must be installed in the antifreeze system to prevent contamination of the potable water supply.
- A/E to show on drawings the hydraulic reference points; description of sprinklers used; system design criteria including density, area of water application, and hose demand if applicable; actual calculated demand; and elevation data.
- A common fire department connection may be provided to serve both the sprinkler system and a wet standpipe system. Consult with MSU Police for the location of the fire department connection.

B. Standpipe and Hose Systems

- Standpipe must be installed in every building over two stories in height above the ground.
- Dry standpipe and hose systems must be installed in open parking structures.
- Standpipes must be four inches in size for any building six stories or under, and six inches in size for any building over six stories.
- All standpipes must normally be wet, and located in stairwells. Intermediate standpipe risers may be needed in long buildings. The standpipe system within the building must be interconnected.

C. Fire Suppression Systems: No CFCs, HCFCs and Halon are used.

11. ACCESS FOR MAINTENANCE AND REPAIR

- A. All equipment shall have a minimum of 3' clear on all sides and 6'8" headroom for service accessibility.
- B. If air dampers, fire dampers, valves, etc., are located above fixed ceilings, access panels must be provided.
- C. When equipment must be installed in relatively inaccessible locations, ladder or stairway shall be provided with proper loops, guards, and/or handrails. Openings in building construction to the equipment shall be not less than 2' X 3' in size and adequate lighting shall be provided at the equipment.
- D. Access platform with ladder/stairway and guards/handrails should be provided to equipment mounted higher than 8' above the floor.
- E. When equipment must be mounted above the roof deck for airflow or roof maintenance considerations, a maintenance catwalk must be installed in the areas requiring service. This catwalk must be constructed of steel grating and must be complete with steps and handrail, all hot dip galvanized. The minimum height of structural frame legs shall be 24" for up to 24" width of equipment, 36" for 25" to 48" width, or 48" for 48" and wider width as recommended by National Roofing Contractors Association.
- F. Maintenance catwalk on roof must be installed from the roof access to the roof-mounted equipment.
- G. Indicate service clearances as recommended by the manufacturers for tube pull and coil replacement on drawing.

END OF SECTION

	PAGE
<u>TABLE OF CONTENTS</u>	<u>1</u>
<u>SITE</u>	<u>2</u>
1. Comprehensive Site Design Guidelines	
2. Universal Accessibility	
3. Sustainability	
4. Considerations and Responsibilities	
5. Pathways	
6. Grading	
7. Vehicle Parking	
8. Road Design	
9. Americans with Disabilities Act Requirements	
10. Obstacles and Protruding Project Problems	
11. Pedestrian Signals	
12. Crosswalk Pavement Markings	
13. Maintenance of Sidewalks in the Vicinity of Construction Sites	
14. Bus Stops	
15. Bicycle Facilities	
16. Building Services Areas	
17. Materials and Installation	
<u>UTILITY INFRASTRUCTURE</u>	<u>20</u>
1. Utility Design	
2. Campus Utility Systems	

1. COMPREHENSIVE SITE DESIGN GUIDELINES

- A. M.S.U. strives for long term quality construction. Not only is an attractive appearance of the campus a primary reason why parents and students select M. S.U. but repeated repairs is not cost effective and, significantly disrupts the effective functioning of this World Class institution 24/7/365 days a year.
- B. Consultants are expected to be thoroughly familiar with and follow the Owner's design and construction standards. Consultants must be granted prior approval for any deviations from MSU Standards (details and specifications) before incorporating them into the Project Documents.
- C. Designs shall adhere to the principles of "Complete Streets", Michigan Public Act 135 of 2010 for all campus streets (roads). "Complete Streets" are roadways that are planned, designed and constructed to provide appropriate access to all legal users in a manner that promotes safe and efficient movement of people of all ages and abilities whether by car, truck, public transportation, transit assistive device, foot or bicycle. The design standards that follow provide guidance to meet and exceed the requirements of the Act. Emphasis shall be placed in order of importance beginning with pedestrians followed by bicyclist then public transportation then personal vehicles and lastly with trucks. The Detailed Site Design Standards incorporate the design provisions for designing Complete Streets. If any section of the MSU Design Standards are more extensive than Complete Streets, than the MSU Standards shall prevail.

2. UNIVERSAL ACCESSIBILITY

- A. Americans with Disabilities Act (ADA), Public Law 101-336 must be followed as the standard in the design of accessible features in new construction and alterations.
- B. Design shall comply with the State of Michigan Barrier-Free Design requirements. When there is a conflict, ADA must govern. When a Michigan requirement exists, and ADA does not, the Michigan code must apply.
- C. Generally, all building entrances, (including loading docks for dollies used by vans and delivery vehicles with-out lift gates shall have ADA regulated ramps) shall be grade level from the path ramp at the adjacent street or barrier free parking. Additional accessible routes may also be required depending on current or future use of the building and/or site.

3. SUSTAINABILITY

- A. Design consideration should include concepts that are appropriate for the project in accordance with The Sustainable Sites Initiative (SITES), as directed by the Owner. It is not the intent of these references to include as many of the scorecard items or benchmarks if they are not truly appropriate for the project goals.
- B. Reference the Low Impact Development Manual for Michigan published by SEMCOG, Southeast Michigan Council of Governments.
- C. Flood Control:

- The first floor elevation of any building shall be a minimum of 12” higher than the highest part of any of the adjacent surrounding roads.
- After the building site has been determined and floor elevations are established, check flood levels and heavy rainfall conditions for any possible problems. Design changes shall be made to eliminate these problems and make the building flood-proof.
- Flood maps of the campus are on file at Infrastructure Planning and Facilities, Engineering and Architectural and Services Division.
- Reference to the historical flood elevations at the Farm Lane Bridge
 - ◇ 1904 – 838.80
 - ◇ 1947 – 835.81
 - ◇ 1960 – 833.59
 - ◇ 1975 – 836.34

D. Storm Water Management: Reference MSU’s stormwater design guidelines.

E. Soil Movement on the Owners Property

- General: In order to limit liability and improve upon the long term planning process the Owner has determined that it is appropriate to track the movement of large quantities of soil onto or around the Owners property. The following policy outlines the procedures for tracking these soils that shall be documented with project records
- Record Keeping: Engineering and Architectural Services (EAS) shall develop and maintain a campus map on the GIS website that includes the following attributes:
 - ◇ Areas of Known soil contamination
 - ◇ Suspect areas requiring further investigation should further development occur
 - ◇ Locations of relocated soils in quantities greater than 500 CY
 - ◇ Soil description and compaction criteria for filled areas if known
 - ◇ Locations of non-contaminated fill that create a future liability for development. Ex: concrete and rubble fill
- Minimum Soil Quantity Requirements: If the project requires the movement of more than 500CY of soil on campus, prior approval from the Vice President for Infrastructure Planning and Facilities. The request shall include appropriate information regarding location, quantities and reason for the soil movement.
- Contaminated Soil Reporting Procedure: If contaminated soils are discovered during construction, the Project Representative will contact the Office of Environmental Health and Safety (EHS) immediately. EHS will inform the VPIPF and direct any required remediation, including maintaining appropriate records indicating quantities, type of contaminants and location for disposal.
- Documentation: IPF staff shall document the location of all contaminated soils and maintain a correspondence records related to the movement of soils regulated by this policy.
- Exempt Activities:
 - ◇ Temporary processing of topsoil for reuse on Owners property
 - ◇ Removal of clean spoils from project site in which the spoils are lawfully disposed of off Owners property

- ◇ Placement of clean existing fill soil or engineered fill soil or topsoil on Owners property.

4. CONSIDERATIONS AND RESPONSIBILITIES

- A. All site planning must conform to the current MSU Campus Master Plan which contains the Campus Planning Principles, System Frameworks, University Zoning Ordinance and various documents and images that are essential for integrating new campus designs into the current fabric of the campus. This information is available at cpa.msu.edu.
- B. Engineering and Architectural Services (EAS) will provide:
 - Benchmarks, floor plans, and other existing information, as required to proceed with planning work
 - A project specific topographic survey
 - An existing vegetation inventory map (including commemorative and historically significant plants)
 - The locations of all historical markers and monuments. All of which shall be preserved
 - Soil reports: boring locations will be determined in coordination with the Consultant for buildings, structures and appropriate site features.
- C. Consultant Responsibilities: Throughout the design process, the site Consultant shall maintain close communication and coordination with the assigned EAS project staff. Coordination by Consultant: The Design Team includes the assigned EAS project staff, other EAS staff, non-IPF MSU employees and other experts that may be hired by MSU.
 - Site Analysis and On-Site Observation: At concept stage, this shall serve to identify site conditions and observe existing site use, therefore identifying site development opportunities and limitations early in the process. Thorough photographic documentation is required.
 - The campus is a dynamic living/learning environment with a prized woody plant collection woven into the fabric of the campus arboretum. Knowledge and respect of the existing plants is essential to provide a successful project. The Director of the Campus Woody Plant Collection and Campus Arborist are available to assist, should you have questions or concerns. It is the responsibility of the Consultant to get prior approval, should the design negatively impact the campus woody plant collection.
 - Design solutions shall integrate sustainable design and best management practices regarding storm water management. Become familiar with the Storm Water Design Standards, which is available on the EAS web site.
 - Roadway, crosswalk, bike lane, bus stop and speed table design standard guidelines require coordination with EAS staff and the University Traffic Engineer. See the Appendix for standard MSU details.
 - Universal Accessibility shall be provided. See Appendix for Barrier-free Roadway Crossing Guidelines.
 - Coordinate heated pavement jointing patterns with planned zones, sensors and manifold locations during the design process. Include EAS Mechanical Engineer and Landscape Architect in the planning.

- Coordinate building service area designs with the Office of Recycling and the Office of Waste Management (rubbish/recycling truck access, bin orientation, location, quantity, size, an type) and Physical Plant Shops (service vehicle parking).
 - Coordinate development of the Landscape Plan Concept with EAS Landscape Architect. Required at end of Design Development for “Step 2 – Authorization to Proceed” presentation.
 - Coordinate utility design with appropriate EAS Staff including a Landscape Architect. The Consultant is expected to facilitate the coordination of such items as aesthetics, tree preservation, noise, maintenance, equipment, drains, storm sewer pipe, manholes, overflow drains and turf irrigation systems. Site lighting, emergency phone (Code Blue) and irrigation circuit plans may be required. Circuit plans shall not be diagrammatic but rather illustrate exact wire routes. Routing shall accommodate subsequent landscape plans. Coordinate with EAS Electrical Engineer and Landscape Architect and consulting Electrical Engineer.
 - Coordinate a construction site access, construction staging, construction barriers, tree protection and any re-routed pedestrian paths (must accommodate snow removal equipment if the project will last through the winter) during construction. Must be included in construction documents (Landscape Services, MSU Police Department, CATA, EAS Civil Engineer may all be involved with these safety and transportation issues).
 - Be familiar with and utilize web-based technical standards, specifications and standard details.
 - ◊ The EAS site detail library, as well and “Design Guideline” drawings, are provided electronically for Consultant use. If unique details are required, contact the assigned EAS project staff. EAS has unpublished details that, with prior approval, may be used and /or slightly modified for the project requirements. See the Appendix for standard MSU details.
- D. Owner Responsibilities: Materials and products furnished and/or installed by Owner are listed in the technical specifications are extensive. Therefore prior approval is required before another product will be approved. Design services by Owner include:
- Assessment of existing plant material
 - Determine items to be salvaged and procedure by Owner or Contractor. (Signs, site lighting, emergency phones, underground wire, street furnishings, parking meters, etc.)
 - Planting plan
 - Irrigation Plan
 - Site furniture selection and procurement by Landscape Architect. (Removal of existing furniture and installation of new by Contractor)
 - Building, regulatory and way-finding sign text and location

5. PATHWAYS

- A. Shall be adjacent to each side of a road where ever physically possible to comply with Complete Streets.

- B. Generally, pathways shall be not less than 8' wide unless specific site conditions require a different width. When adjacent to the front of parking spaces, the minimum shall be 9.5' to accommodate parking meters, vehicle overhang of the curb and snow plowing operations.
- C. Walking paths shall be constructed of a minimum of 6 inch thick concrete per the Standard Detail, unless otherwise specified. Other materials and porous pavements will be seriously considered if it fits within the esthetic framework of the site.
- D. Concrete pavement immediately adjacent to roadway curb must contain the brick detector border per the Standard Detail. Pavement adjacent to parking spaces does not require a brick detector border.
- E. ADA barrier-free ramps with tactile warning plates shall be at all pathways that cross vehicle routes including where paths terminate in or cross parking lots. They shall be aligned with the crosswalk where ever possible incorporating the brick band visual aid indicator where ever needed. Warning plates shall not be more than 30" away from the back of curb.
- F. Perpendicular intersection walkway radii shall be at least equal to the walk width. Acute angle radii shall be no more than 1 foot.
- G. Pavement at building entrances shall be frost free and separated from the approaching pathway with an expansion joint and supported by a haunch attached to the building wall or a spread footing adjacent to the building. They shall be cured using the wet cure method out to 50' and then waterproofed after a minimum 30 days drying time after which the standard specified waterproofing product will be applied in accordance with the manufacturers recommendations.
- H. All construction joints shall be constructed with epoxy coated dowels per the Standard Detail.
- I. All expansion joints shall have Greenstreak brand, Speed Dowels per the Standard Detail.
- J. Pavement adjoining a building or foundation shall be constructed with an expansion joint and haunch, speed dowel or frost free footing.

6. GRADING

- A. Detailed grading plan shall show spot elevations at the key forming junctures such as corners, points of tangency, top and bottom of curb/wall etc.
- B. Storm water drainage patterns shall minimize flow across or within pedestrian and bicycle travel ways.
- C. Shall conform to Federal ADA rules.
- D. Valley gutters shall be constructed of concrete that is 3 feet wide and 12 inches thick reinforced concrete except where its located between a road/driveway and parking

spaces, in which the thickness can be reduced to 10 inches. Valley gutters that are crossed by vehicles shall remain at 12 inches.

7. VEHICLE PARKING

- A. Parking space requirements – standard perpendicular spaces shall be 9' x 18' (excluding the gutter pan at the side of the space at ends of the parking bay). Two perpendicular parking bays and one drive lane shall be 60 feet wide.
- B. Concrete curb and gutter shall be 24" wide; (integral curbs are rarely approved). Straight curb is generally prohibited unless site conditions don't allow for the Standard Detail curb/gutter.
- C. Rolled curbs should be poured in locations where snow plows need to push snow review locations with landscape services.

8. ROAD DESIGN

- A. Lane Width: All vehicle lanes shall be 10 feet wide with 5 feet wide (single direction) bike lanes (asphalt pavement surface) (see bike lane design requirements in section 5). Service drives may be wider to accommodate larger vehicles and turning requirements. Bike lanes can be reduced to 4 feet wide if significant woody plant conflicts prohibit the 5 foot lane.
- B. Clear Vision Zones: Plans shall identify all clear vision zones throughout the road, paying particular attention to intersections and curves.

9. AMERICANS WITH DISABILITIES ACT REQUIREMENTS

- A. Curb Ramps at Vehicle Crossings
 - Where conditions permit, the slope of the ramp shall be in only one direction, parallel to the direction of travel through the marked crosswalk.
 - Curb ramps shall be provided wherever an accessible route crosses a curb/gutter regardless whether it's marked or not.
 - Desired design of sidewalk ramps includes the figures below which direct the pedestrian in the direction of travel/marked crosswalk.

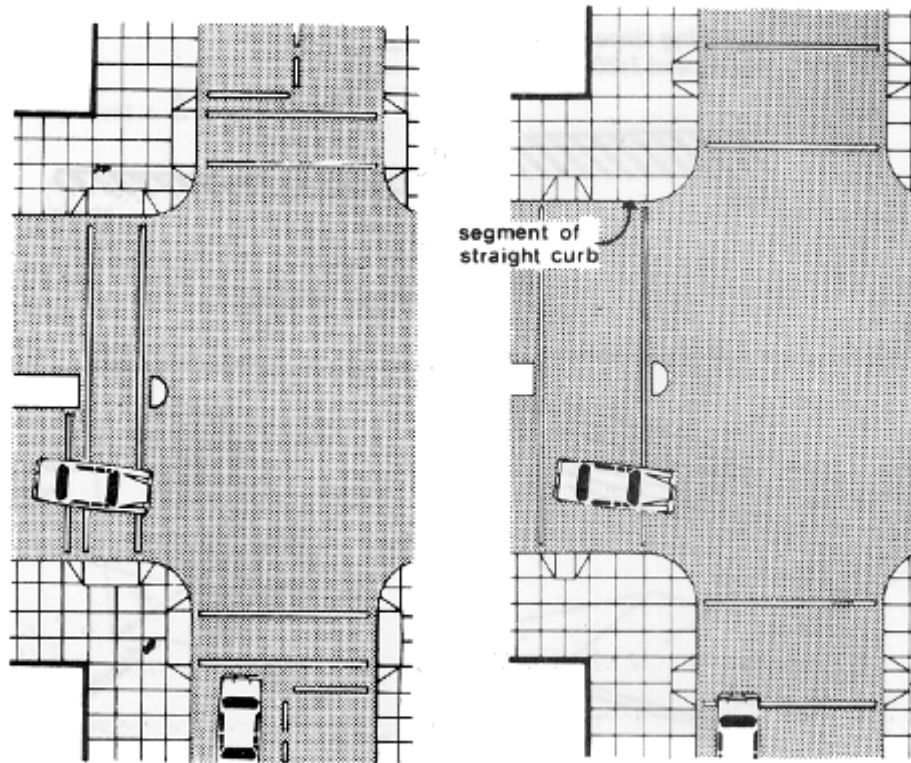

- The ramp slope is a ratio equal to the vertical rise (y) divided by the horizontal run (x). It is equal to the tangent of the angle that the plane of the ramp surface makes with a horizontal (level) plane. Transitions from ramps to walks, gutters, or streets shall be flush and free of abrupt changes. Maximum slopes of adjoining gutters, road surface immediately adjacent to the curb ramp, or accessible route shall not exceed 1:20

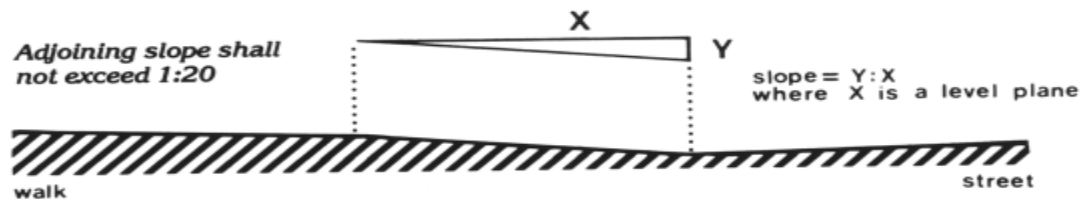

- The minimum width of a curb ramp shall be 36 in (915 mm), exclusive of flared sides.
- Ground surfaces along accessible routes and spaces including curb ramps shall be stable, firm, and slip-resistant.
- If a curb ramp is located where pedestrians must walk across the ramp, or where it is not protected by handrails or guardrails, it shall have flared sides; the maximum slope of the flare shall be 1:10.

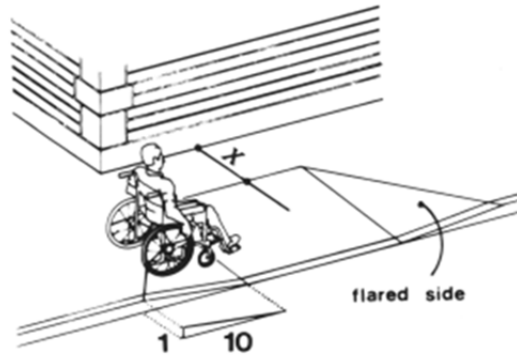

Note: if X is less than 48 in. then the slope of the flared side shall not exceed 1:12

- This figure shows a typical curb ramp, cut into a sidewalk perpendicular to the curb face, with flared sides having a maximum slope of 1:10. The landing at the top, measured from the top of the ramp to the edge of the walkway or closest obstruction is denoted as "x". If x, the landing depth at the top of a curb ramp, is less than 48 inches, then the slope of the flared side shall not exceed 1:12
- Where the curb ramp is completely contained within a planting strip or other non-walking surface, so that pedestrians would not normally cross the sides, the curb ramp sides can have steep sides including vertical returned curbs.
- Where the curb ramp is completely contained within a planting strip or other non-walking surface, so that pedestrians would not normally cross the sides, the curb ramp sides can have steep sides including vertical returned curbs.

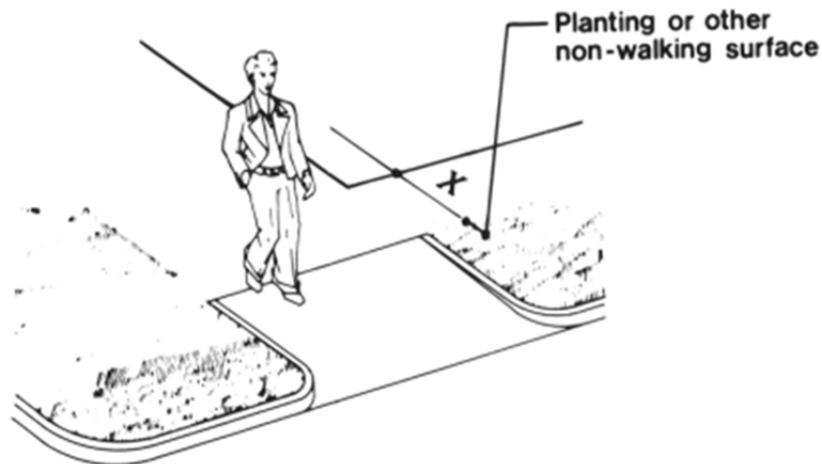

- Defined curb height where the two streets intersect provides two distinctive curb ramps for the two sidewalks. This allows individuals with Visual Impairments to detect a left or right edge to the curb ramp and subsequently avoid diagonal crossing into the intersection

B. Detectable Warning Device: Detectable warnings shall consist of a surface of truncated domes.

- Positioning: A curb ramp shall have a detectable warning. The detectable warning shall extend the full width of the curb ramp (exclusive of flared sides)

and shall extend either the full depth of the curb ramp or 24 inches (610 mm) deep minimum measured from the back of the curb on the ramp surface.

- Dome Size: Truncated domes in a detectable warning surface shall have a base diameter of 0.9 inch (23mm) minimum and 1.4 inches (36 mm) maximum, a top diameter of 50 percent of the base of the diameter minimum to 65 percent of the base diameter maximum, and a height of 0.2 inch (5.1 mm).
- Dome Spacing: Truncated domes in a detectable warning surface shall have a center-to-center spacing of 1.6 inches (41 mm) minimum and 2.4 inches (61 mm) maximum, and a base-to-base spacing of 0.65 inch (17 mm) minimum, measured between the most adjacent domes on a square grid.
- Contrast: Detectable warning surfaces shall contrast visually with adjacent walking surfaces either light-on-dark, or dark-on-light.
- Platform Edges: Detectable warning surfaces at platform boarding edges shall be 24 inches (610 mm) wide and shall extend the full length of the public use areas of the platform.
 - ◇ Material Specifications: Detectable warnings must be made from cast iron. The approved vendor is East Jordan Iron Works, East Jordan, MI 800-874-4100.

C. Sidewalks Parallel to Road Edge: Where sidewalks or paved areas are adjacent to the roadway and there is not a definable separation of surface character between the pavement edge and curb/gutter of the road, this presents a hazard to pedestrians in areas where lighting is poor or if the pedestrian has a visual impairment. The following solutions are appropriate:

- Turf: In areas which are wide enough to adequately maintain turf, place a continuous strip of turf to separate the sidewalk from the curb/gutter edge of the road.
- Planters: Place a continuous ADA designed planter to separate the sidewalk from the curb/gutter of road
- Differentially Textured Hard Surface: Place a band of contrasting colored bricks for a width of at least 17 inches between the sidewalk and the curb/gutter of road.

10. OBSTACLES AND PROTRUDING OBJECT PROBLEMS:

- A. Obstacles and protruding objects in sidewalks present hazards to pedestrians with and without vision loss, and can create barriers for individuals traveling in wheelchairs or using crutches or other mobility aids, and individuals walking or riding bicycles or walking in small and large groups. Obstacles and protruding objects include, but are not limited to: vegetation, signs, posts, emergency phones, light poles, benches, bollards, rubbish cans, traffic signal poles or similar type obstructions.
- B. Signs: Where parking or pedestrian movements occur, the clearance to the bottom of the sign(s) shall be at least 7 feet (2.1 m) above the level of the pavement edge. Signs must not protrude into the pedestrian path of travel. Sign posts are to be located parallel to the pedestrian path of travel with the signage positioned perpendicular to the path of travel.
- C. Protruding Objects: Objects between 27 in. and 80 in. (685 mm and 2030 mm) above ground and not detectable by cane shall not protrude more than 4 in. (100 mm) into sidewalks, corridors, or passageways (including objects mounted on a wall). Objects

mounted with their leading edges at or below 27 in. (685 mm) above the finished floor may protrude any amount. Free-standing objects mounted on posts or pylons may overhang 12 in. (305 mm) maximum from 27 in. to 80 in. (685 mm to 2030 mm) above the ground or finished floor. Protruding objects shall not reduce the clear width of an accessible route or maneuvering space. Protruding objects may be protected by a barrier (including a vertical curb or similar structure) that is detectable.

- D. Head Room: Sidewalks, corridors, passageways, or other circulation spaces shall have 80 in. (2030 mm) minimum clear head room. If vertical clearance of an area adjoining an accessible route is reduced to less than 80 in. (nominal dimension), a barrier to warn blind or visually-impaired persons shall be provided.
- E. Bollards: When a bollard is placed in the pavement, the following solutions are available to warn of the hazard:
- Color Contrast: A contrasting color on the bollard is desired (dark green bollard on light colored concrete or white bollard on blacktop as examples of color contrast only and not to be used as specific colors that are approved), to allow for better visual detection of bollards in settings with low lighting and by individuals with visual impairments.
 - Flared-bottom Design: The use of bollards with a flared-bottom design is desired as compared to pole design, to allow for the detection of the bollard by individuals in low light and by individuals who are blind and use a long cane.
- F. Vegetation: Protruding vegetation which are not maintained can present hazards and sight line concerns for pedestrians, bicyclists, and motorists.
- Unobstructed sidewalk or bike path: Vegetation shall be maintained to provide a clear route on sidewalks and bike paths. All plant material shall be cleared at least one (1') foot from the pavement edge and eight (8 ft.) above the pavement. In areas of low light, or for individuals with visual impairments, a protruding branch can be a severe hazard to pedestrians and cyclists.
 - Sight Line: In areas where vegetation will be added to the landscape, consideration needs to be made with regard to the planting space and areas where pedestrians, cyclists and vehicles may intersect. It is important to consider the mature growth of the vegetation related to the sight line for motorists, cyclists, and pedestrians.

11. PEDESTRIAN SIGNALS

- A. An accessible pedestrian signal detector shall be defined as a device designated to assist the pedestrian who has visual or physical disabilities in activating the pedestrian phase. At accessible pedestrian signal locations, pushbuttons should clearly indicate which crosswalk signal is actuated by each pushbutton. Pushbuttons and tactile arrows should have high visual contrast as described in the "Americans with Disabilities Act Accessibility Guidelines for Buildings and Facilities (ADAAG)". Tactile arrows should point in the same direction as the associated crosswalk.
- B. Acceptable Vendors & Vendor Standards:

- Michigan State University uses the Polara 2 Wire Navigator Accessible Pedestrian Signal (http://www.polara.com/Nav_Features.htm) which can be ordered through Carrier & Gable, Inc. (<http://www.carriergable.com/>) – 10/2008.
 - Michigan State University adheres to the Michigan Department of Transportation (MDOT) Special Provision for Accessible Pedestrian Signal System: 03T820 (243) - <http://mdotwas1.mdot.state.mi.us/public/dessssp/spss/gotoview.cfm>, with the following additions/addendums:
 - ◇ 2.A.08 – The Owner uses the MUTCD & MDOT authorized regulatory sign size.
 - ◇ 2.A.08 – The Owner uses contracted Braille for the street name placed on the regulatory sign.
 - ◇ 2.C.07 – The Owner uses the standard color: BLACK
 - ◇ The Owner standard message is: “Street Name” followed by “walk sign” to indicate the crossing.
- C. Location of Push Buttons for Accessible Pedestrian Signals: In locations where pedestrians must actuate the signal for crossing (i.e., mid-block crossings, intersections which are not “time controlled” for classes, etc.) the following standards are required:
- Adjacent to a level all-weather surface to provide access from a wheelchair, and where there is an all-weather surface, wheelchair accessible route to the ramp;
 - Within 1.5 m (5 ft.) of the crosswalk extended;
 - Within 3 m (10 ft.) of the edge of the curb, shoulder, or pavement; and
 - Parallel to the crosswalk to be used.
- D. Button Locations: Road without Median: If two accessible pedestrian pushbuttons are placed less than 10 feet apart or on the same pole, each accessible pedestrian pushbutton shall be provided with the following features:
- A pushbutton locator tone,
 - A tactile arrow,
 - A speech walk message for the WALKING PERSON (symbolizing WALK) indication, and
 - A speech pushbutton information message.
 - Contracted Braille “Street Name” on the regulatory sign.
- E. Button Location – Road with Median: If the pedestrian clearance time is sufficient only to cross from the curb or shoulder to a median of sufficient width for pedestrians to wait and accessible pedestrian detectors are used, an additional accessible pedestrian detector shall be provided in the median.
- F. Pushbutton Locator Tones:
- Pushbutton locator tones shall be easily locatable, shall have a duration of 0.15 seconds or less, and shall repeat at 1-second intervals.
 - Pushbuttons should be audibly locatable. Pushbutton locator tones should be intensity responsive to ambient sound, and be audible 1.8 to 3.7 m (6 to 12 ft) from the pushbutton, or to the building line, whichever is less.

- Pushbutton locator tones should be no more than 5 dBA louder than ambient sound.
- The audible tone(s) may be made louder (up to a maximum of 89 dBA) by holding down the pushbutton for a minimum of 3 seconds. The louder audible tone(s) may also alternate back and forth across the crosswalk, thus providing optimal directional information.

G. Audible Message Standard

- When verbal messages are used to communicate the pedestrian interval, they shall provide a clear message that the walk interval is in effect, as well as to which crossing it applies. The verbal message that is provided at regular intervals throughout the timing of the walk interval shall be:
- MSU Standard: “Street Name” to be crossed followed by “walk sign” to indicate the crossing. (i.e., “Farm Lane, walk sign”).

H. Countdown Pedestrian Signals

- Standard Pedestrian Signal Head: A pedestrian interval countdown display may be added to a pedestrian signal head in order to inform pedestrians of the number of seconds remaining in the pedestrian change interval.
- Accessible Pedestrian Signal Detectors: In areas where the Owner has installed or is using visual countdown pedestrian signals, the audible countdown features within the accessible pedestrian signal pushbuttons will be activated.
- Timing: 3.5 ft/second timing Face-to-Face/curb-to-curb crossing. The assumed flashing “do not walk” is based upon walking speed for pedestrian at 3.5 ft/second from face of curb to face of curb. The minimum walk time should be 20 seconds.
- Pedestrian button activation: Reluctant to rely on the activation of a button by a pedestrian, the button shall always be on recall.

12. CROSSWALK PAVEMENT MARKINGS

- A. Evaluate each situation separately with approval from the University Traffic Engineer. Crosswalk pavement markings standards are as follows:

crossing Type	Heavy Use	Moderate to Light Use
Signalized Intersection	Zebra	Zebra
Road with Stop Sign	Zebra	Standard
Driveway with Stop Sign	Standard	Standard
Mid-Block Crossing	Zebra	Zebra
Parking Lot Entrance	Standard	Standard
Crossing in Parking Lot	Zebra	Standard
Roundabouts	Zebra	Zebra

13. MAINTENANCE OF SIDEWALKS IN THE VICINITY OF CONSTRUCTION SITES

- A. Pedestrian Considerations - A wide range of pedestrians might be affected by temporary traffic control (TTC) zones, including the young, elderly, and people with disabilities

such as hearing, visual, or mobility. These pedestrians need a clearly delineated and usable travel path which would include:

- Advance notification of sidewalk closures shall be provided and published to the university community.
- Where there are closed sidewalks, a lighted barrier fencing that is detectable by a person with a visual disability traveling with the aid of a long cane shall be placed across the full width of the closed sidewalk and/or work site.
- Where there are blocked routes, alternate crossings and channelizing routes detectable to pedestrians traveling with the aid of a long cane or who have low vision shall be provided and maintained around the work site.
- Alternate crossings and channelizing routes must include curb ramps and accessibility features for individuals using wheelchairs.
- Sign and signal information should be used to communicate routes around construction to pedestrians.

B. Planning Considerations for Pedestrians in Temporary Traffic Control (TTC) Zones:

- Pedestrians should not be led into conflicts with work site vehicles, equipment, and operations.
- Pedestrians should not be led into conflicts with vehicles moving through or around the work site.
- Pedestrians should be provided with a reasonably safe, convenient, and accessible path that replicates as nearly as practical the most desirable characteristics of the existing sidewalk(s).
- Where pedestrians who have visual disabilities encounter work sites that require them to cross the roadway to find an accessible route, instructions should be provided using an audible information device. Accessible pedestrian signals with accessible pedestrian detectors might be needed to enable pedestrians with visual disabilities to cross wide or heavily traveled roadways.
- A pedestrian route should not be severed and/or moved for non-construction activities such as parking for vehicles, storage of construction equipment or construction materials.

C. When pedestrian movement through or around a work site is necessary, a temporary separate usable sidewalk shall be provided.

- If the previous pedestrian facility was accessible to pedestrians with disabilities, the temporary pathway should also be accessible.
- No abrupt changes in grade or terrain that could cause a tripping hazard or could be a vertical barrier to wheelchair use.
- The sidewalk shall be continuous with curb ramps and all accessibility features.

D. Accessible TTC Zones need to include the following:

- Provisions for continuity of accessible sidewalks should be incorporated into the TTC planning process.
- Access to temporary transit stops shall be provided.

- When channelization is used to delineate a sidewalk, a continuous detectable edging should be provided throughout the length of the sidewalk such that pedestrians using a long cane can be guided.
- A smooth, continuous hard surface should be provided throughout the entire length of the temporary sidewalk. There should be no curbs or abrupt changes in grade or terrain that could cause tripping or be a barrier to wheelchair use.
- The width of the sidewalk should be a minimum of 1500 mm (60 in.) for the temporary route. Traffic control devices and other construction materials and features should not intrude into the usable width of the sidewalk (permanent or temporary). When it is not possible to maintain a minimum width of 1500 mm (60 in) throughout the entire length of the sidewalk, a 1500 x 1500 mm (60 x 60 in) passing space should be provided at least every 60 m (200 ft), to allow individuals in wheelchairs to pass.
- Signs and other devices mounted lower than 2.1 m (7 ft) above the temporary sidewalk should not project more than 100 mm (4 in) into accessible sidewalks.

14. BUS STOPS

- A. Location, size and shape shall be approved by the Owner in consultation with CATA.
- B. Bus Stop Location: On two way/two lane roads, locate the bus stop diagonally across from each other with the Bus Stop before the crosswalk. On two lane same direction roads, the bus stop shall be after the crosswalk (refer to standard details). Position at least one street light at the crosswalk (two for multi-lane roads). This layout, provide the maximum sight line for motorist to see departing bus riders who are crossing the road.

15. BICYCLE FACILITIES

A. Bike Paths/Lanes

- Road Bike Lanes: Dedicated bike lanes shall be on all streets and roads. Bike lanes shall be constructed of bituminous pavement. They shall be 5' wide whenever possible measured from the face of the gutter pan. However, a narrower bike lane to a minimum of 4' may be approved by the Owner, if existing obstructions (trees, mechanical systems, etc.) dictate the reduction in width.
- Bike Paths: Dedicated bike paths shall be 1) 5' wide in each direction, 2) adjacent to each other and 3) adjacent to the sidewalk, if one exists nearby and 4) shall be constructed using the Owners standard bituminous material used for parking lots, unless an alternate surface material has been selected by the Owner.

B. Bicycle Parking Areas

- Size and Location: Bike parking areas shall be aesthetically and conveniently located near building entrances. Size of the parking area should accommodate the demand for that entrance, to the extent possible without compromising the buildings appearance.
- Hardware: Specify the standard detail, unless an alternate design has been selected by the Owner.

16. BUILDING SERVICE AREAS

- A. Provide sufficient space to accommodate rubbish and recycling operations (as well as grease handling containers for buildings with food service) in sufficient size that is appropriate for the intended use of the building without interfering with the normal operation of the dock or building operations.
- B. Provide space for MSU service vehicle parking (coordinate with EAS)
- C. Adequate space for special use vehicles that require frequent trips daily (quantity to be furnished by EAS)
- D. Barrier-free parking spaces shall also be accommodated in the service area if no other area is available.
- E. Snow storage area shall be accommodated in the service area design.
- F. Provide a visual barrier (structural and/ or vegetation) from adjacent road/sidewalk.

17. MATERIALS AND INSTALLATION

A. Concrete Pavement

- Thickness and reinforcement
 - ◇ Light Duty: (Pedestrian pavement): Minimum of 6" thick without reinforcement.
 - ◇ Heavy Duty: 8" thick with 4x4 4 gauge, both ways, reinforcement mesh. Pavement width should be at least 10', with larger radii so vehicles can remain on the pavement, especially when turning.
- Heated Pavement: Shall be a minimum of 8" thick with 4x4x6ga.both ways, reinforcement mesh supported by slab on ground plastic or continuous metal chair with a sand plate (also designated as CHCP in the trade). Chairs will be mechanically secured to soil grade to prevent the piping from allowing the mesh and chairs from rising off the grade. All tubing shall be 4 inches from the edge of the heated pavement to reduce the potential of damage during adjacent pavement replacement or for excavation for utility repairs. Acceptable alternative design would be to place 2 inches of foam insulation beneath the concrete and change the tubing chairs to standard chairs, eliminating the CHCP chair.
 - ◇ Heated pavement shall extend from the threshold of the door to the barrier-free parking spaces. With EAS approval, some parking space pavement may also be heated.
 - ◇ See the standard detail for the manifold vault which shall be located at the intersection of pavement joints. Coordination with Mechanical Engineer will be required to insure the manifold vault is correctly located.
 - ◇ The Consultant will develop a conceptual plan identifying all the Areas in the heated pavement which will include the manifold vault locations. The Mechanical Engineer will use this plan to lay out the tubing plan.

The Project Designer, Consultant and the Mechanical Engineer will work together should adjustments be necessary.

- ◇ Heated pavement beneath pavers should be avoided if possible.
 - ◇ Tubing within a supported slab shall be isolated.
 - ◇ Include balancing valves in manifold vaults to reduce the need for uniformly sized tube lengths and to improve uniform heat distribution
- Service Dock Aprons: 10” with a minimum of 2 layers of 4x4 4 gauge, both ways, mesh or greater. The concrete aprons will extend at least 50’ from the dock to include both the front and rear axles of most delivery vehicles to reduce bituminous pavement deterioration from diesel fuel spillage and front tire ruts.
 - Roll-off and compactor bins: Where compactor bins are positioned, place steel plates to protect the concrete from the damage caused by the bin wheels. Plates should extend beyond the front of the bin a sufficient distance so the wheels and guides never come in direct contact with the concrete. Consult with Recycling /Waste Management (884-03580) for bin size that will be used for the project.
 - For reinforced concrete as specified, identify on the plans, all concrete to be reinforced per specification Section 323212, 3.2
 - Reinforcement mesh or rod shall overlap above all casting structure ring flange surfaces.

B. Jointing:

- Refer to the standard details for joint location and construction.
- Include all standard joint details.
- Identify all expansion and control joints on drawings.
- Pavement 10’ wide or greater shall have a center longitudinal joint.
- Flags shall be jointed to be a close to square as possible but not more than 25 % greater in one dimension than the other.
- Joints shall be perpendicular to the edge of the pavement or tangent.
- Joint spacing shall be less than 10’
- A “T” control joint must terminate at an expansion or construction joint.
- A “T” expansion joint must terminate at another expansion joint.
- Install dowels, keyways or haunches where potential for settlement exists, such adjacent to building foundations, over new utility lines, filled excavations or over engineered fill more than 18” deep.
- Joints shall be straight (without bends or curves) unless approved by the Owner.

C. Construction joints: Shall have epoxy dowels positioned per the standard detail.

D. Expansion joints:

- Shall have Speed Dowel brand dowels positioned and spaced per the standard detail.
- Shall always isolate pavement sections.
- Isolate all structural elements.

E. Prohibited Concrete Surfaces

- Exposed aggregate (without prior approval)
- Stamped concrete
- Surface-applied color
- Steel toveled finishes
- Concrete pavers
- Broken concrete and any surface treatment where a stumbling potential is possible, especially for the visually impaired or blind.

F. Concrete Curb and Gutter:

- Identify on the plans, all curb and gutter is to be reinforced. See Section 321613, 3.2
- Standard curb/gutter is 24" wide x 12" high
- Standard gutter pan is 9" thick.
- Valley gutter [3' wide x 12" thick and 2" deep (8" thick along parking bays) and reinforced by three #4 bar] shall always be located where concentrated water flow exists. Center road water flow lines are not acceptable.
- Jointing
 - ◇ Control joints shall be 2 inches minimum depth (saw cut only if necessary) after the surface has been tooled (refer to the standard detail).
 - ◇ Expansion Joints
- Layout
 - ◇ Tangent points shall transition with any visible point between the curve and the straight section

G. Bituminous Pavement

- Specify only MSU standard bituminous pavement systems. If the area being paved has both parking and roadway/loading docks design for the most severe use.
- If the design includes porous pavement, the limits shall be appropriately located to maximize durability, reduce the frequency of raveling and completely surrounded by concrete curb/gutter.

H. Brick Pavers: Concrete pavers are not approved. Clay brick paver other than the standard color requires prior approval. Brick pavers are considered as a surface treatment only. All brick shall be supported by 6" concrete pavement below and reinforced if necessary according to the Specifications and Standard Details. Include drainage system.

I. Pavement Marking Milling: Milled the surface prior to the installation of all thermoplastic and cold plastic for new bituminous pavement and Polyurea thermoplastic (for concrete pavement only) used for road markings (including bike lanes) symbols and arrows. The only exception is parking space lines.

J. Earthwork

- Consultant shall be familiar with the Owner's detailed earthwork specification, including in particular regarding scarification and removing of construction

debris from subsoil after construction activities have ended and prior to topsoil placement.

- All topsoil shall be furnished by the Owner from a location on the Owners property.

UTILITY INFRASTRUCTURE

1. UTILITY DESIGN

- A. Where possible, all utilities should come into one area in the building.
- B. If steam tunnel approaches can be located under the means of access between the universally designed barrier free entrance and the bus drop-off location and the accessible parking area, entry snow melting systems can be eliminated or reduced in size. Tunnels should be close enough to the surface to assure snow-melting effectiveness equivalent to a snow melting system.
- C. Excavation plans should indicate all underground utilities and the effects of new grading should be carefully coordinated with existing utilities, trees and other appurtenances.
- D. The elevation and location of underground utilities shall be field verified by excavation or other reliable means during design.
- E. On one drawing, all existing and all new utilities shall be field verified by excavation or other reliable means during design.
- F. All new and existing utilities are to have profile drawings to show elevations for construction and clearances from other utilities.
- G. Information and data pertaining to utilities will be provided by Engineering and Architectural Services.
- H. Design of all new utilities will be performed under the direction of Engineering and Architectural Services.

2. CAMPUS UTILITY SYSTEMS

- A. The following utility systems are located underground throughout the campus: (See Construction Standards Section 02550 – Site Utilities):
 - Steam: Central high pressure steam is available at 70-90 psi to most new structures for heating, air conditioning and other needs. This system is generally extended via walk-through tunnels which house steam supply and pumped condensate. (See Construction Standards Section 336320 – Steam and Condensate Utility Distribution.)
 - Potable Water: Potable water is provided by a central distribution system at 50-60 psi into each structure. Softening on a limited basis is provided in buildings requiring it. (See Construction Standards Section 331000 – Water Distribution System.)

- **Chilled Water:** In various parts of the campus, chilled water for air conditioning purposes is available from a regional chilled water plant.
- **Sewers:** Sanitary sewers are connected to central sewer system leading to the city sewage plant. Storm water is run separately into a central storm system leading to the river. (See Construction Standards Section 02513 – Drainage Structures, and Section 02520 – Drainage Pipe.)
- **Natural Gas:** Natural gas is taken from Consumers Power medium pressure system available on campus. (See Construction Standards Section 02551 – Gas Distribution System.)
- **Electric:** Electricity is provided by the 13,200 volt distribution system. (See Construction Standards Section 337119 – Electric and Communication Distribution.)

Communications: Communication networks are generally installed in concrete encased duct banks. (See Construction Standards Section 337119 – Electric and Communication Distribution.)



MICHIGAN STATE UNIVERSITY

STORM WATER DESIGN STANDARDS

STORM WATER DESIGN PROCEDURE

I. PURPOSE

It is the purpose of these storm water design standards to establish minimum storm water management requirements for all projects that are completed on the Michigan State University (MSU) campus to meet the following objectives:

- Ensure that storm water drainage systems and BMPs are adequate to address storm water management needs within a proposed project area and protect the campus from flooding and degradation of water quality.
- Minimize the degradation of the Red Cedar River.
- Maintain to the greatest extent practicable, balanced pre-development site hydrology in terms of the ratio of storm water runoff, groundwater recharge and evapo-transpiration.
- Keep MSU in compliance with their storm water discharge permit.

Further documentation of the impacts of development on land and water resources and the importance of storm water management can be found in Chapter 2 of the *Low Impact Development Manual for Michigan* (SEMCOG, 2008).

http://www.semco.org/uploadedfiles/Programs_and_Projects/Water/Stormwater/LID/LID_Manual_chapter2.pdf

II. DESIGN PROCESS

The storm water site design process is summarized in **Table 1**. This process requires definition of the following:

- Sensitive Areas
- Volume Control Criteria
- Storm Water Management Zones
- Adequate Outlet
- Special Cases
- Selection of Best Management Practices

Table 1 – Design Process Flow Chart

Step	Description	Check	Tools
1	Locate site in campus watershed and determine storm water management zones and special cases.		Campus Watershed Map (Figure 1)
2	Designate “disturbance” areas and identify sensitive areas on site.		
3	Identify soil types, <u>pre-development</u> and <u>existing</u> land uses for curve number calculations.		Green Calculator
4	Identify existing flow paths to determine time of concentration.		Green Calculator
5	Layout site, protecting sensitive areas and leaving room for BMPs.		
6	Identify developed land uses for curve number calculations including non-structural BMPs .		Green Calculator
7	Calculate time-of-concentration for <u>developed</u> site.		Green Calculator
8	Select and size structural BMPs to meet required stream protection volume.	If calculated stream protection volume is not sufficient then return to Step 5. If site constraints preclude meeting the required volume, apply for approval of extended detention approach or consider using storm water credits from regional project.	Green Calculator ED Curves
9	Check peak flows for 10-year and 25-year event (flood control). Check adequate outlet.	If peak <u>developed</u> discharge exceeds allowable peak discharge, calculate required detention storage volume, select structural BMPs .	Worksheet 1 Green Calculator Rational Spreadsheet
10	Check safe passage of 100-year flood.		
11	Check that minimum water quality volumes are met.	If not already met through stream protection and flood control measures, select and size structural BMPs to meet.	Green Calculator
12	Select and size structural BMPs for pre-treatment and spill containment (where necessary).		

A. Sensitive Areas

Steps 1 and 2 of the design process require that the site be assessed in regard to its location in the watershed, and inventoried for existing on-site resources and/or special conditions (sensitive areas) that may pose a challenge and/or opportunity for storm water management. A Campus Watershed Map is included as **Figure 1**. For the purpose of these rules, sensitive areas include:

- Floodplains (and floodprone areas)
- Wetlands
- Rivers, streams and natural drainage ways
- Lakes and ponds
- Soils and topography (steep, erodible)
- Geology
- Groundwater supplies (springs, wellhead protection areas)
- Vegetation (woodlands, other sensitive ecosystems)
- Historic Sites

Identification of sensitive areas and “disturbance areas” on the site plan is required in Part 1 of this manual. “Disturbance Areas” are categorized as:

- No disturbance area
- Minimal disturbed area
- Construction traffic area
- Topsoil stockpiling and storage area

The watershed-scale assessment is completed by identifying the Storm Water Management Zones and Special Cases that may modify the required storm water volume controls as discussed in the following sections.

B. Volume Control Criteria

Volume-based criteria is essential to mitigate the impacts of urban runoff. Adequate controls are required to reduce channel erosion, maintain groundwater recharge, prevent overbank flooding and meet pollutant removal goals through the use of:

- Stream Protection Volume
- Flood Control Volume
- Water Quality Volume
- Pre-treatment Volume

A summary of sizing criteria is provided in **Table 2**. A comparison of the resulting storage volumes required for the various criteria is presented in **Figure 2**.

Table 2 – Summary of Standard Sizing Criteria

Volume Control	Minimum Sizing Criteria
<p>Stream Protection <i>(volume and peak rate control)</i></p>	<p>(1) Onsite Retention: No net increase in the pre-development runoff volume and rate from the disturbed portion of the site for the 2-year, 24-hour rainfall event.</p> <p>OR if site constraints preclude (1):</p> <p>(2) Extended Detention: Storage volume and release rate determined by extended detention of the 1-year, 24-hour rainfall event for a period of 24 hours.</p> <p>OR if site constraints preclude (2):</p> <p>Determine Volume Control Requirement and apply for storm water credit from a regional project.</p>
<p>Flood Control <i>(peak rate control)</i></p>	<p>If Stream Protection (1) is provided: Detention of the 25-year, 24-hour rainfall event with a maximum release rate not to exceed the pre-developed 25-year peak runoff rate.</p> <p>OR</p> <p>If Stream Protection (2) is provided: Detention of the 25-year, 24-hour rainfall event with a 0.10 cfs/acre maximum release rate.</p>
<p>Extreme Flood</p>	<p>Overland flow paths must assure safe passage of 100-year flood events.</p>
<p>Water Quality</p>	<p>Treat runoff from the first 1.0-inch of rain from the directly connected impervious area and disturbed pervious area through settling (permanent pool or extended detention), infiltration, or filtration.</p>
<p>Pre-treatment</p>	<p>Settling basins (forebay): Provide 15% of the water quality volume.</p> <p>OR</p> <p>Vegetated Filter Strips and Grassed Swales meeting minimum length, slope and vegetated cover requirements.</p> <p>OR</p> <p>Proprietary Treatment Systems (Nutrient box, cyclone separator or bay separator)</p>

1. Red Cedar Hydrology

Evaluation of USGS gage records for the Red Cedar River and hydrologic modeling of the river highlighted factors important to evaluating the impact of new campus development on stormwater runoff. All of the developed areas on campus drain directly into the Red Cedar River; therefore protection efforts are focused entirely on how changes impact the river.

Hydrologic modeling and gage data show that runoff from the urban area (including the MSU campus) occurs about two days before the flood peak on the Red Cedar River. Detention storage that significantly delays stormwater runoff from campus in most cases will increase the peak flow on the river.

The analysis of the river also shows that a significant portion of runoff that occurs at Quick Return Flow (water that infiltrates into the soil and is intercepted by tile drains and storm sewers). This reflects the high water table in the basin and that much of the agricultural land is tile-drained and the urban areas have intense drainage networks. Soil borings throughout campus show a high water table in many areas. When evaluating the change in runoff volume from new development it is important to recognize that many times under existing conditions most of the water that infiltrates is returned to the river quickly through the drainage system. In those cases there may not be significant change in runoff volume.

In conclusion, stormwater protection efforts on campus need to focus on improving the water quality of the Red Cedar River. When addressing the water quantity (volume) standard on campus it is important to recognize the unique hydrologic circumstances of the area.

2. Stream Protection Volume

Retention of a stream protection volume is required to control urban storm water runoff for the smaller, more frequent 1- to 2-year rainfall events (bankfull flood) that have a greater impact on the stability of headwater (or low-order) streams. Retention of the increase in volume for a 2-year storm between pre-developed and post-development conditions is required. Volume control for stream protection may also provide additional benefits by promoting groundwater recharge (that can provide for more stable stream base flows and cooler water temperatures), sustaining wetland hydrology and maintaining floodplain boundaries.

The 2-year storm was selected since 95% or more of the annual average runoff volume will be controlled, including all storms of a lesser frequency (encompassing the bankfull event). A pre-development condition is defined as a maximum runoff condition associated with the existing conditions as of July 1, 2010. The storage provided by the selected criteria will also serve to reduce peak flow rates for larger rainfall events.

Where retention is not possible due to site constraints, (see Special Cases section below), extended detention of the stream protection volume may be approved. Detention of the total 1-year runoff volume for a period of 24 hours is required to mitigate the impact of an increased volume of flow at the bankfull discharge. The idea is that storm water runoff will be stored and released in such a gradual manner (significantly less than the bankfull discharge rate) that critical erosive velocities during the bankfull and near-bankfull events will seldom be exceeded in downstream channels. The smaller

storm is selected to avoid releasing extended volumes of runoff from the 2-year storm at the bankfull discharge rate, since it is better to have a higher peak for a much shorter duration at that point.

3. Flood Control Volume

Although site-based storm water runoff rate control may help protect the area immediately downstream from a campus project site, the increased volume of runoff and the prolonged duration of runoff from multiple campus project sites can actually increase peak flow rates and duration of flood flows in downstream watercourses. Replicating 2010 runoff volumes for small (2-year) storms will substantially reduce the problem of frequent flooding. When 2-year volume control is provided, detention of storm water runoff for the 25-year flood event with a corresponding 2010 release rate is required to maintain peak flow rates and floodplain levels in downstream watercourses.

Where 2-year volume control is not provided, detention of the 25-year event with an allowable release rate of 0.10 cfs/acre is required. This approach is overly conservative with the allowable release rate to prevent the increase in peak flow rates further downstream as explained in the previous paragraph.

The peak discharge for the extreme flood event must be checked to verify that either infrastructure, overland flow routes and/or floodplains are present to safely convey the storm water runoff.

4. Water Quality Volume

Water quality volume is required to treat the “first flush” of storm water runoff that typically carries with it the highest concentration of pollutants. Capturing the runoff from the 90-percent annual non-exceedance storm is required to effectively treat all runoff from a majority (90%) of storms in a given year. In Lansing (Michigan Climatic Zone 9), the 90-percent storm is equivalent to 1.9 inch of rain.

Capturing and treating runoff from the 90-percent annual non-exceedance storm has been found to generally meet pollutant load targets of:

80% decrease in total suspended solids (TSS); or
discharge concentrations of TSS less than 80 mg/L

A majority of these pollutants build up on the surface of roadways and parking areas. Directly connected disturbed pervious surfaces (primarily lawns) can also contribute pollutant load (i.e. nutrients due to overuse of fertilizer; nutrients and bacteria due to overuse by wild/domestic animals). Impervious surfaces that meet the definition of “disconnected” (see Storm Water Disconnection BMP in Part 3) can be omitted from water quality calculations.

Water quality volume can be provided through one of the following methods:

- Permanent pool
- Extended detention
- Infiltration
- Filtration

The volume of a permanent pool incorporated into a storm water BMP can be counted as water quality volume. This is the volume below the ordinary static water level (also known as dead storage).

Extended detention is defined as holding the storm water runoff volume and releasing it gradually over a longer period of time than provided by conventional detention basins. The minimum extended detention time is 24 hours, and is defined as the time between the centroids of the inflow and outflow hydrographs. The storage volume provided by extended detention can be counted as water quality volume.

The volume of storm water runoff infiltrated into the ground through a storm water BMP can be counted as water quality volume. Guidelines for determining this volume are specified in the calculation credits for each structural infiltration BMP.

The volume of storm water runoff routed through a BMP that provides filtration (i.e. an underdrained BMP) can be counted as water quality volume. In the case of a vegetated filter strip or grassed swale, the filtering area must meet minimum standards for slope, length and vegetative cover for a maximum allowable drainage area to filter strip ratio of 6:1.

5. Pre-Treatment Volume

Pretreatment provides for the removal of fine sediment, trash and debris, and is required to preserve the longevity and function of storm water best management practices, particularly infiltration practices. A minimum pre-treatment volume equivalent to 15% of the water quality volume is required for sediment forebays using gravity. This approximates results given by the Hazen Equation for sediment basin sizing using a 50% settling efficiency for a 50 micron particle (silt) and a 1-year peak inflow. Other methods of pre-treatment including the use of water quality devices and vegetated filter strips or grassed swales are allowed.

Pre-treatment is required for all infiltration BMPs (except pervious pavement), filters and detention basins, and may be necessary for some storm water reuse systems.

C. Adequate Outlet

1. In general, the existing storm sewer pipe network has adequate capacity to accept new storm water flows. The following requirements must be met to avoid adverse impacts to downstream facilities. An adequate outlet worksheet is provided as Worksheet 1.

2. Existing infrastructure (storm sewer, culverts and ditches)

Post-development discharge shall not exceed the capacity of the existing drainage system. The adequate outlet standard is generally considered to be met by the following measures:

- a. Provide 2-year volume control with 10-year peak rates no greater than existing condition.
- b. Provide 25-year detention requirements.
- c. For a downstream drainage system that is inadequate to handle the proposed discharge from the site development, it is the project's responsibility to upsize the existing conveyance system, or establish a drain to provide the needed design level of flood protection.

3. Offsite ponds, wetlands and depressions

Discharge rate and volume shall not cause adverse impact to offsite property due to water levels of greater height, area and duration. The no net increase of storm water standard is generally considered to be met by the following measures:

- a. Provide 2-year volume control and check that any rise in 100-year level causes no adverse impact.

Worksheet 1

ADEQUATE OUTLET WORKSHEET

Project: _____ Date: _____

Location: _____ By: _____

Watershed Sub Basin: _____

Discharge to	Control Provided <i>(Check all that apply)</i>	Certificate
Direct discharge to Red Cedar River <i>Describe:</i> _____ _____ _____	<input type="checkbox"/> Minimum storm water discharge standards met.	Adequate Outlet
Existing infrastructure (storm sewer, culverts and ditches) <i>Describe:</i> _____ _____ _____	<input type="checkbox"/> 2-year volume control and 10-year peak rate no greater than pre-developed. <input type="checkbox"/> 25-year detention requirements. <input type="checkbox"/> Approval for alternative peak discharge rate of _____ cfs/acre	Adequate Outlet
	<input type="checkbox"/> Project will improve downstream county drainage system.	
Offsite ponds, wetlands and depressions <i>Describe:</i> _____ _____ _____	<input type="checkbox"/> Volume standards met and no adverse impact from any increase in 100-year level.	No Net Increase of Storm Water
	<input type="checkbox"/> Proprietor will obtain flooding easements.	

D. Special Cases

The standard criteria outlined above may not be necessary or suitable for certain sites. In addition, some types of BMPs may be totally unsuitable for consideration in special land use areas and should be excluded from application. A worksheet to document the special cases that apply to the proposed project is included as **Worksheet 2**. The special cases most frequently encountered are additions to existing buildings that have very limited greenspace or the new building site does not have adequate greenspace footprint to develop BMPs.

1. Site Constraints

Site constraints may inhibit the ability of the project to provide full retention of the 2-year volume difference onsite. In many cases, infiltration will likely be used as the primary means of retention. Site constraints that limit the use of infiltration may include:

- Poorly draining soils
- High groundwater or the potential to mound groundwater around buildings
- Well-head protection areas

a. Additional Criteria

A waiver of the required retention volume (stream protection criterion 1) may be granted due to site constraints and be deemed eligible for credit from a regional project. The project must show the following to use the extended detention stream protection criterion (2):

- The LID design process (**Table 1**) was followed.
- Volume reduction is maximized to the greatest extent practicable.
- The cost to implement additional volume reduction BMPs is prohibitive, or would force noncompliance with local zoning ordinances.

b. Required Strategies

It should be noted that the presence of poorly draining soils on a site does not automatically preclude meeting the 2-year retention criteria since required volumes will be smaller, and BMPs that do not rely on infiltration such as tree planting (evapotranspiration) and storm water reuse can be employed.

2. Redevelopment

a. Additional Criteria

A stream protection volume “credit” is available for redevelopment sites. Stream protection volume criterion (1) may be modified for redevelopment sites as follows:

- No net increase in the existing runoff volume and rate from the disturbed portion of the site for the 2-year, 24-hour rainfall event.

Existing runoff volume and rate shall be the volume and rate after routing through all existing storm water controls.

F. Selection of Best Management Practices

Select appropriate storm water BMPs from the Storm Water BMP Summary Matrix. The BMP or combination of BMPs selected must meet required volume and peak rate criteria. The need for pre-treatment is indicated for each type of BMP. Those BMPs that can be selected to provide water quality volume control, pre-treatment and spill containment are also indicated. Operation and maintenance requirements are summarized for each BMP in terms of the need for a maintenance plan, easement and/or restrictive covenant.

Finally, each best management practice is designed in accordance with the guidelines provided in the BMP Fact Sheets comprising Chapters 6 and 7 of the *Low Impact Development Manual for Michigan* (SEMCOG, 2008) and supplementary design criteria provided in Part 3 of this manual.

G. Consideration of Offset by Regional Project

The design professional should determine the cost for meeting the storm water quality requirements and volume control requirements for the project. (See example project calculations table.) After the cost is determined, the storm water steering committee will determine if the project should proceed with an onsite solution, or if it would be more cost effective to offset the parameters with a regional project.

Storm Water BMP Application Matrix

Storm Water BMP	Storm Water Benefits			Application		Location	
	Runoff Volume Reduction	Peak Rate Reduction	Water Quality Improvement	Retrofit Existing Facility	New Development	Regional Facility	Site Specific
Structural BMP's							
Bioretention (Raingarden)	X	X	X	X	X		X
Capture/Reuse	X	X	X	X	X	X	X
Catch Basin Inlet Device			X	X	X		X
Constructed Filter			X	X	X		X
Constructed Wetland	X	X	X	X	X	X	
Dry Detention Pond		X			X	X	X
Extended Detention		X	X		X	X	X
Hydrodynamic Separator			X	X	X		X
Infiltration Basin	X	X	X		X	X	X
Infiltration Trench	X	X	X		X		X
Native Revegetation	X		X	X	X		X
Parking Structure	X	X			X	X	
Pervious Pavement	X	X	X		X		X
Planter Boxes	X		X	X	X		X
Riparian Buffer Restoration	X		X	X	X		X
Sediment Basin			X	X	X		X
Soil Restoration	X		X	X	X		X
Subsurface Infiltration Bed	X	X	X	X	X		X
Tree Planting	X		X	X	X		X
Underground Detention		X		X	X		X
Vegetated Filter Strip			X	X	X		X
Vegetated Roof	X	X	X		X		X
Vegetated Swale			X	X	X		X
Wet Detention Pond		X			X	X	X
Non-Structural BMP's							
Catch Basin Cleaning			X	X	X	X	X
Storm Sewer Inspection			X	X	X	X	X

STORM WATER DESIGN CRITERIA

I. SOILS INVESTIGATION

A. Qualifications

Soils investigation by a qualified geotechnical consultant is required when it is necessary to determine the site soil infiltration characteristics and groundwater table. The geotechnical consultant shall be either a registered professional engineer, soil scientist, or geologist licensed in the State of Michigan.

B. Background Evaluation

An initial feasibility investigation shall be conducted to screen proposed BMP sites. The investigation involves review of the following resources:

- County Soil Survey prepared by the NRCS and USDA Hydrologic Soil Group classifications.
- Existing soil borings or geotechnical report on the site prepared by a qualified geotechnical consultant.
- Onsite septic percolation testing within 200 feet of the proposed BMP location and on the same contour.

C. Test Pit / Soil Boring Requirements

A test pit (excavated hole) or soil boring (minimum 2-inch diameter drilled hole using a bucket auger, probe, split-spoon sampler or Shelby tube) is allowed for geotechnical investigation. Test pits may typically be selected for shallower investigations in locations where groundwater is sufficiently low, and must comply with applicable OSHA safety standards. The minimum number of test pits or soil borings shall be determined from **Table 6**.

Table 6 – Minimum Number of Soil Tests Required

Type of BMP	Test Pit / Soil Boring	Depth of Test Pit / Soil Boring	Field Permeability Test
Linear infiltration BMP	1 soil boring per 100 linear feet of BMP; 2 minimum	10 feet below proposed bottom	1 test per soil boring
Linear infiltration BMP (> 500 feet)	1 soil boring per 500 linear feet of BMP; 4 minimum	10 feet below proposed bottom	1 test per soil boring
Infiltration BMP	1 soil boring per 5,000 square feet of BMP bottom area; 2 minimum	10 feet below proposed bottom	1 test per soil boring
Detention BMP	1 soil boring per 10,000 square feet of BMP bottom area; 1 minimum	5 feet below proposed bottom	Not Applicable

Excavate a test pit or soil boring in the location of the proposed BMP.

At each test pit or soil boring, the following conditions shall be noted and described, referenced from a top-of-ground elevation:

- Depth to groundwater. The groundwater elevation shall be recorded during initial digging or drilling, and again upon completion of drilling.
- Depth to bedrock or hardpan.
- Depth and thickness of each soil horizon, including the presence of mottling.
- USDA soil texture classification for all soil horizons.

Test pit reports and soil boring logs shall include the date(s) data was collected and the location referenced to a site plan.

D. Field Permeability Testing

Field permeability testing is generally not required, but may be performed to determine if a design infiltration rate higher than indicated in **Table 7** may be used.

- Infiltration Rate of Soils in Field Using Double-Ring Infiltrimeters (ASTM D-3385)
- Percolation Tests

The methodologies and procedures outlined on pages 440-441 in Appendix E of the *Low Impact Development Manual for Michigan* (SEMCOG 2008) shall be followed for each test.

http://www.semco.org/uploadedfiles/Programs_and_Projects/Water/Stormwater/LID/LID_Manual_appendixE.pdf

An additional factor of safety of two (2) shall be applied to the permeability test results by the following equation:

$$\text{Permeability-test infiltration rate (inches/hour)} / 2 = \text{Design infiltration rate (inches/hour)}$$

The minimum number of field permeability tests shall be determined from **Table 6**.

Tests shall be conducted in the location of the proposed BMP at the proposed bottom elevation.

Tests shall not be conducted in the rain or within 24 hours of significant rainfall events (>0.5 inch), or when the temperature is below freezing.

Field permeability testing reports shall include the date(s) data was collected and the location referenced to a site plan.

E. Design Infiltration Rates

Where field permeability testing is not performed, the design infiltration rates provided in **Table 7** shall be used to size BMPs.

Table 7 – Design Infiltration Rates by USDA Soil Texture Class

Soil Texture Class	Effective Water Capacity ¹ (inches per inch)	Design Infiltration Rate ² (inches per hour)	Hydrologic Soil Group ¹
Gravel*	0.40*	10*	A
Sand	0.35	3.60	A
Loamy Sand	0.31	1.63	A
Sandy Loam	0.25	0.50	A
(Medium) Loam	0.19	0.24	B
Silty Loam / (Silt)	0.17	0.13	B
Sandy Clay Loam	0.14	0.11	C
Clay Loam	0.14	0.03	D
Silty Clay Loam	0.11	0.04	D
Sandy Clay	0.09	0.04	D
Silty Clay	0.09	0.07	D
Clay	0.08	0.07	D

¹Source: Rawls, Brakensiek and Saxton, 1982 (*Maryland Stormwater Design Manual*, Maryland Department of Environment, 2000, Appendix D.13, Table D.13.1)

²Source: Rawls 1998 (*Site Evaluation for Stormwater Infiltration (1002)*, Wisconsin Department of Natural Resources, Conservation Practice Standards, 2004, Table 2)

*Not included in original tables. Source: Masserman, Joel W., *A Design Manual for Sizing Infiltration Ponds*, Washington State Department of Transportation Commission, 2003, Table 8 - Estimated Long-Term Infiltration Rate

Table 7 provides design values of the effective water capacity (Cw) and the minimum infiltration rate (i) of the specific soil textural groups. The effective water capacity of a soil is the fraction of the void spaces available for water storage, measured in inches per inch. The minimum infiltration rate is the final rate that water passes through the soil profile during saturated conditions, measured in inches per hour. The soil textures presented in **Table 7** correspond to the soil textures of the USDA Textural Triangle at the end of this section. The values for design infiltration rate are modified from the original Table D.13.1 in the *Maryland Stormwater Manual* based on design values recommended by other sources (Massman, 2003 and WDNR, 2004) to be more reflective of long-term infiltration rates.

The least permeable soil horizon within four (4) feet below the proposed BMP bottom elevation shall be used to select the design infiltration rate.

F. Minimum Allowable Infiltration Rate

Soil textures with design infiltration rates less than 0.24 inches per hour are deemed not suitable for infiltration BMPs. Modifications to the BMP design through the use of underdrains or subsoil amendment, or selection of an alternative BMP shall be required.

For design infiltration rates between 0.10 and 0.24 inches per hour, BMP design may include an underdrain placed at the top of the storage bed layer.

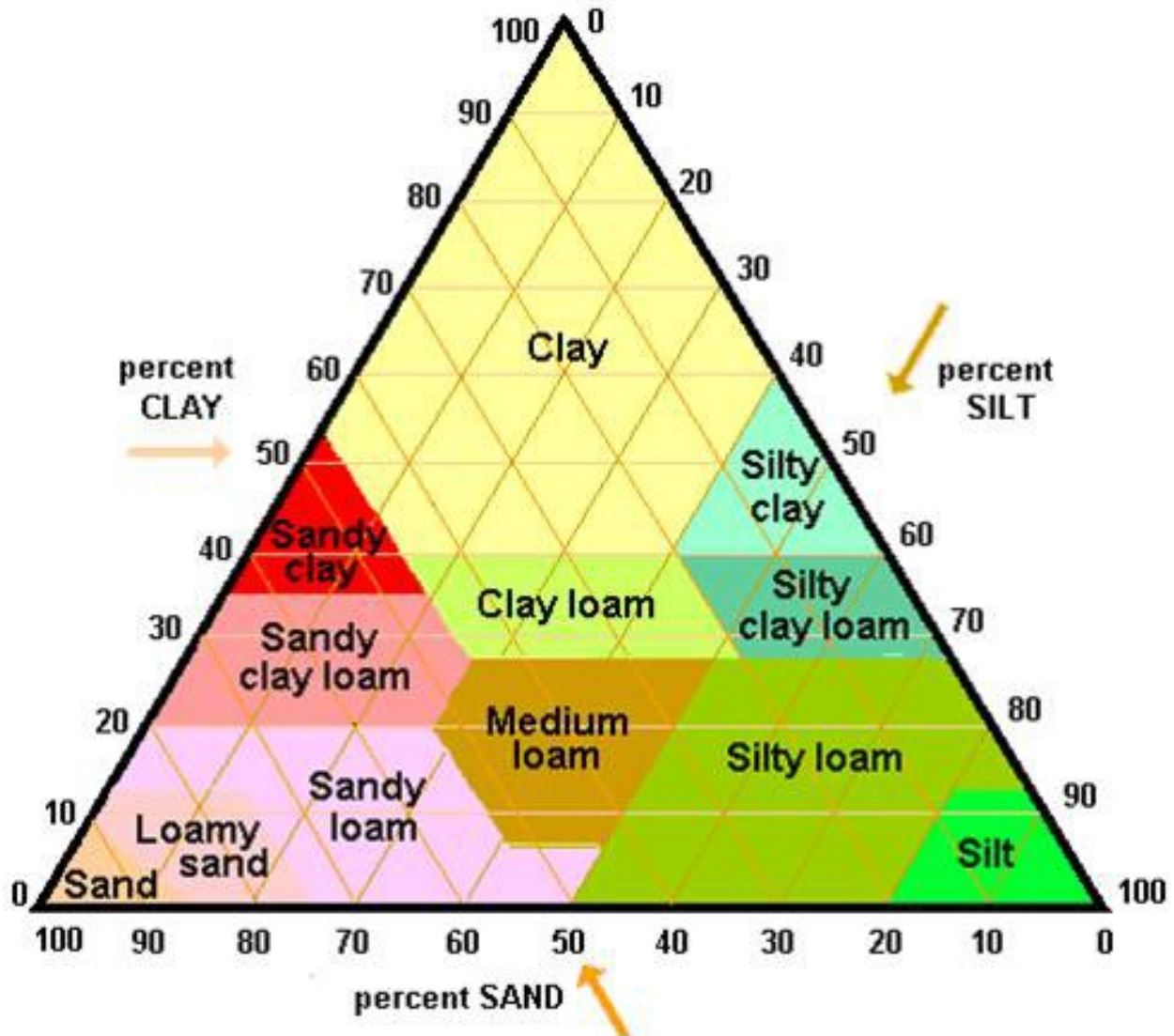

USDA SOIL TEXTURAL TRIANGLE

II. CALCULATION METHODOLOGY

A. Calculating Runoff

1. Rainfall Loss Equations and Runoff Coefficients

- a. The Runoff Curve Number Method, developed by the NRCS, shall be used to calculate storm water runoff. The resulting formulas are as follows:

$$Q_v = \frac{(P - 0.2S)^2}{(P + 0.8S)}$$

where:

Q_v = surface runoff volume (inches)

P = rainfall (inches)

S = potential maximum retention after runoff begins (inches)

and where:

$$S = \frac{1000}{CN} - 10$$

Surface runoff volumes are calculated separately for impervious and pervious areas.

- b. Curve Number (CN) values shall be taken from Technical Release No. 55 (TR-55). Standard values are summarized in **Table 8** for convenience.

Table 8 – Curve Numbers (CNs) from TR-55

Cover Description		Curve Number			
Cover Type	Hydrologic Condition	A	B	C	D
Woods	Fair	36	60	73	79
	Good	30	55	70	77
Meadow		30	58	71	78
Open spaces (grass cover)	Fair	49	69	79	84
	Good	39	61	74	80
Paved parking lot, roof, driveway, etc.		98	98	98	98

Source: *Urban Hydrology for Small Watersheds, Technical Release No. 55*, U.S. Department of Agriculture Soil Conservation Service, 1986.

- (1) Pre-development conditions shall consist of a “Meadow” cover type for all existing land covers other than woods. For existing woods use the “Woods” cover types for “good” hydrologic conditions.
 - (2) Open space in “fair” condition shall be used for post-development pervious areas that are not receiving non-structural and restorative structural BMP credits.
- c. A Unit Hydrograph-based Method shall be used to generate peak storm water runoff rates.
 - d. An antecedent moisture condition of II, reflective of normal soil moisture, shall be used with the NRCS or Modified Michigan Unit Hydrograph Method.
 - e. Other methodologies and computer models listed in Chapter 9 of the *Low Impact Development Manual for Michigan* (SEMCOG, 2008) may also be accepted with the following limitations.
 - (1) The Rational Method shall only be used to generate peak discharges to size conveyance systems for sites less than 1.5 acre where it is not necessary to calculate volume reduction of flows entering the conveyance system. The peak runoff rate is given by the equation:

$$Q = CIA$$

where:

Q = peak runoff rate (cubic feet per second)

C = the runoff coefficient of the drainage area

I = the average rainfall intensity for a storm with a duration equal to the time of concentration of the drainage area (inches per hour)

A = the drainage area (acres)

- (2) Runoff coefficients for various land uses and surface types are included in **Table 9**.

Table 9 – Rational Method Runoff Coefficients

Type of Development	Runoff Coefficients
Business Downtown Neighborhood	0.70 to 0.95 0.50 to 0.70
Residential Single family Multi-units (detached) Multi-units (attached)	0.30 to 0.50 0.40 to 0.60 0.60 to 0.75
Residential (suburban)	0.25 to 0.40
Apartment	0.50 to 0.70
Industrial Light Heavy	0.50 to 0.80 0.60 to 0.90
Park, Cemeteries	0.10 to 0.25
Playgrounds	0.20 to 0.35
Railroad Yard	0.20 to 0.35
Unimproved	0.10 to 0.30
Character of Surface	
Pavement Asphalt and Concrete Brick	0.70 to 0.95 0.70 to 0.85
Roofs	0.75 to 0.95
Lawns, Sandy Soil Flat 2% Average 2% to 7% Steep 7%	0.05 to 0.10 0.10 to 0.15 0.15 to 0.20
Lawns, Heavy Soil Flat 2% Average 2% to 7% Steep 7%	0.13 to 0.17 0.18 to 0.22 0.25 to 0.35

Source: *Design and Construction of Sanitary and Storm Sewers*, American Society of Civil Engineers and the Water Pollution Control Federation, 1969.

2. Time of Concentration

a. Travel time for use with a unit hydrograph-based method shall be calculated using NRCS TR-55 methodology.

(1) The flow path is split into three sections – sheet flow, shallow concentrated flow, and open channels. In each flow regime the velocity and/or travel time are computed. The time-of-concentration is then the sum of the travel times.

(a) For sheet flow the travel time (in hours) is given as:

$$\frac{0.007(nL)^{0.8}}{P_2^{0.5}s^{0.4}}$$

where n is Manning's factor, L is the flow length (feet), P_2 is the 2-year precipitation depth, and s is the slope (feet/foot). Multiply this value by 60 minutes per hour to obtain travel time in minutes.

(b) Shallow concentrated flow velocities are calculated for paved and unpaved surfaces. The velocities are given as:

$$v = \begin{array}{l} 16.1345s^{0.5} \quad \text{Unpave} \\ 20.3282s^{0.5} \quad d \\ \text{Paved} \end{array}$$

where s is the slope (feet/foot) and v is the velocity in feet per second. The flow length (feet) is then divided by the velocity (feet per second) and a conversion factor of 60 seconds per minute to obtain travel time in minutes.

(c) Open channel flow uses Manning's equation to calculate the velocity based on slope, flow area, and wetted perimeter. The flow length (feet) is then divided by the velocity (feet per second) and a conversion factor of 60 seconds per minute to obtain travel time in minutes.

b. BMP residence time shall be calculated as the storage volume divided by the 10-year peak flow rate.

c. Overland flow time for use with the Rational Method may be calculated using the nomograph below. A minimum of 15 minutes shall be used.

The following is a table used for determining n

<u>TYPE OF SURFACE</u>	<u>n VALUE</u>
Smooth impervious surface	0.02
Smooth bare packed soil	0.10
Poor grass, cultivated row crops or moderately rough bare surface	0.20
Pasture or average grass	0.40
Deciduous Timberland	0.60
Conifer Timberland, Deciduous Timberland with deep forest litter or dense grass	0.80

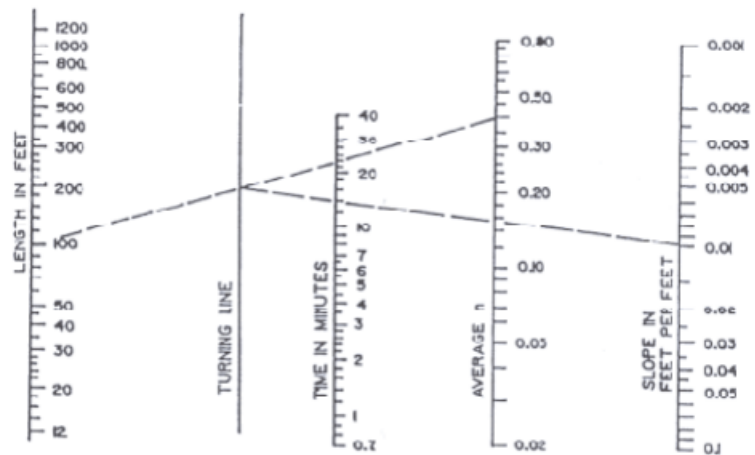

Example: $n=0.40$, $L=100'$, $S=0.01$ feet/foot and $t_c=13.6$ minutes

Chart is printed from the following equation.

$$t_c = \left(\frac{2Ln}{3\sqrt{S}} \right) \times \frac{1}{2.14}$$

Taken from ENGINEER'S NOTEBOOK

"Time of concentration for overland flow" W.S. Kerby, J.M. Asce, Hydrologist, Servis, Van Doren & Hazard, Engineers, Topeka, Kansas.

The variables needed to compute time of concentration for a proposed development are its length, slope, and surface retardants. These variables can be computed from field survey notes.

The length L is the distance from the extremity of the development area in a direction parallel to the slope until a defined channel is reached. The units are in feet. Overland flow will become channel flow within 1,200 feet in almost all cases. Time of concentration is the sum of overland flow and channel flow.

The slope S is the difference in elevation between the extremity of the drainage area and the point in question divided by the horizontal distance. The units are in feet/foot.

The surface retardants coefficient, n, is the average surface retardants value of the overland flow.

3. Rainfall

- a. The 24-hour rainfall amounts from *Rainfall Frequency Atlas of the Midwest, Bulletin 71* (Huff and Angel, 1992) provided in **Table 10** shall be used the Unit Hydrograph Method.
- b. The rainfall duration-frequency table from *Rainfall Frequency Atlas of the Midwest, Bulletin 71* (Huff and Angel, 1992) provided in **Table 10** shall be used the Rational Method to determine a rainfall intensity for a rainfall duration equal to the time of concentration.
- c. A Type II rainfall distribution shall be used with the Unit Hydrograph Method.

Table 10 – Rainfall Amounts

Duration	1-year	2-year	5-year	10-year	25-year	50-year	100-year
24-hr	1.62	2.09	2.70	3.21	3.89	4.47	5.08
18-hr	1.52	1.96	2.54	3.02	3.66	4.20	4.78
12-hr	1.41	1.82	2.35	2.79	3.38	3.89	4.42
6-hr	1.22	1.57	2.03	2.41	2.92	3.35	3.81
3-hr	1.04	1.34	1.73	2.05	2.49	2.86	3.25
2-hr	0.94	1.21	1.57	1.86	2.26	2.59	2.95
1-hr	0.76	0.98	1.27	1.51	1.83	2.10	2.39
30-min	0.60	0.77	1.00	1.19	1.44	1.65	1.88
15-min	0.44	0.56	0.73	0.87	1.05	1.21	1.37
10-min	0.34	0.44	0.57	0.67	0.82	0.94	1.07
5-min	0.19	0.25	0.32	0.39	0.47	0.54	0.61

Source: *Rainfall Frequency Atlas of the Midwest, Bulletin 71*, Huff and Angel, 1992, Table 5 – Michigan, Section 8

B. Calculating Storage Volumes and Release Rates

1. Stream Protection using Onsite Retention (1)

$$V_{sp} = V_{2dev} - V_{2pre}$$

where:

V_{sp} = minimum required stream protection volume (cubic feet)

and

$$V_{2dev} = A(Q_{V_{dev-perv}} + Q_{V_{dev-imp}})1/12$$

$$V_{2pre} = A(Q_{V_{pre-perv}} + Q_{V_{pre-imp}})1/12$$

where:

V_{2dev} = runoff volume of the 2-year, 24 hour storm for proposed development conditions

V_{2pre} = runoff volume of the 2-year, 24-hour storm under pre-development conditions

A = contributing disturbed site area (acres)

Q_v = surface runoff volume (inches) by Runoff Curve Number Method

1/12 = factor to convert inches to feet

The stream protection volume must be retained onsite. This may be accomplished through infiltration, storm water reuse, interception and/or evapotranspiration.

The Green Calculator is a Microsoft Excel spreadsheet application that uses a unit hydrograph-based storm water runoff method with NRCS Curve Numbers (CN) and time-of-concentration formulas. It calculates required treatment volumes and detention release rates for individual site drainage areas and allows the user to select non-structural and structural BMPs to meet required runoff rates and volumes. Output is graphed as hydrographs and summarized in tabular form for a range of rainfall frequencies (2, 5, 10, 25, 50 and 100-year). A copy is provided with this manual.

2. Stream Protection using Extended Detention (2)

Extended detention of the total runoff from the 1-year, 24-hour rainfall event to achieve a 24-hour lag between the centroid of the outflow hydrograph and the inflow hydrograph is required when the second stream protection approach is used. The resulting storage volume and maximum allowable release rate are determined from reservoir routing. Multiple simulations were performed for the "Curve Number Method" as described in *Lower Grand River Watershed, Stormwater Management for Stream Protection: Development of Michigan Statewide Rating Curves for Extended Detention Control of the Stream Protection Volume*, FTC&H, 2009.

Required release rates and storage volumes per acre are calculated for CN values of 70 to 98 and can be selected from the curves provided below.

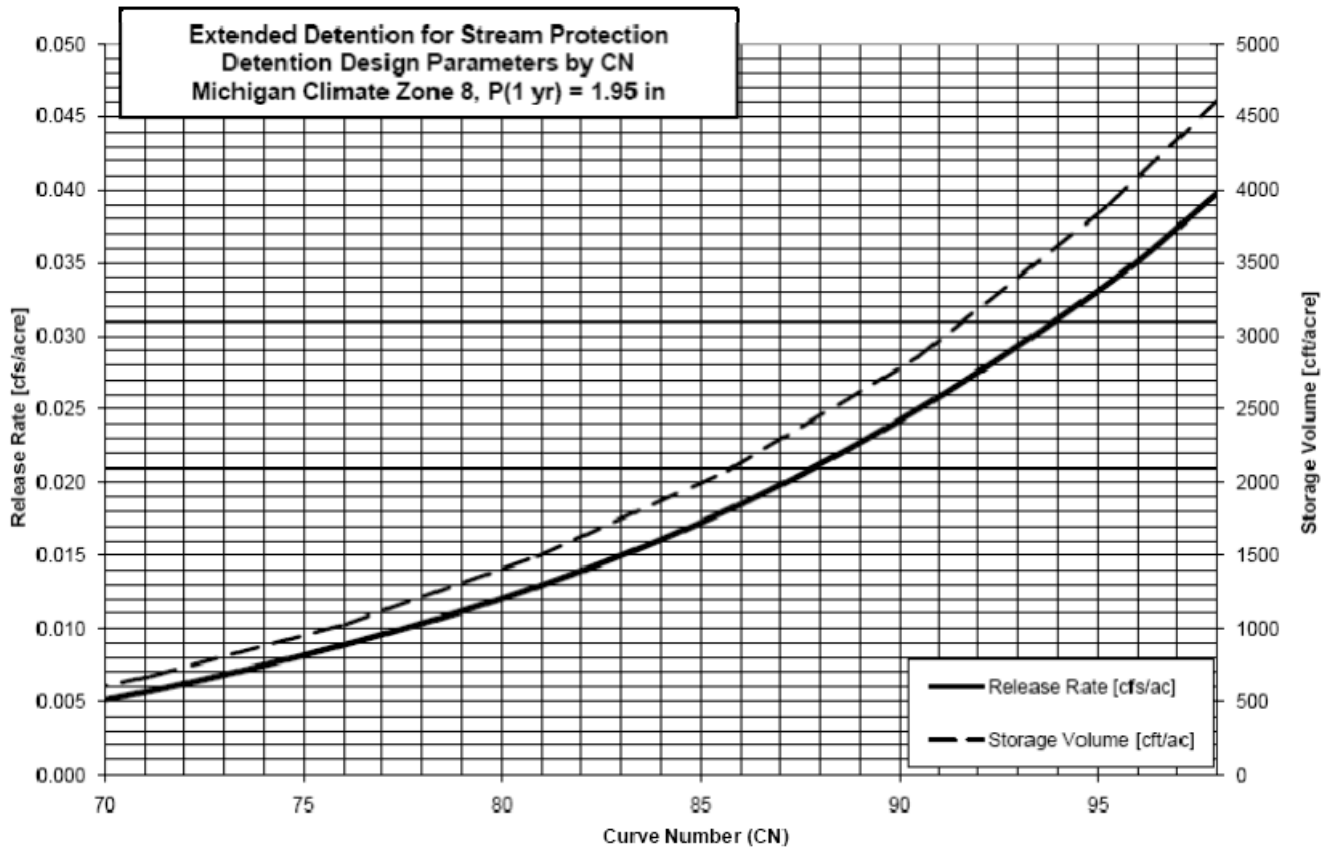

Source: *Lower Grand River Watershed, Stormwater Management for Stream Protection: Development of Michigan Statewide Rating Curves for Extended Detention Control of the Stream Protection Volume*, FTC&H, 2009.

3. Flood Control using Detention Basins

The standard flood control criteria consists of detention of the 25-year, 24-hour rainfall event. Maximum allowable release rates are dependent upon which stream protection criteria is selected. If 2-year onsite retention is used, 25-year peak discharge rates must not exceed pre-development peak runoff rates. If 1-year extended detention is used, a 25-year maximum allowable release rate of 0.10 cfs/acre is required. The required storage volume is determined by reservoir routing with the Runoff Curve Number Method. The Green Calculator will compute the required 25-year detention storage volume for the calculated inflow hydrograph given a user-specified release rate.

The Rational Method may be used to determine the volume of detention storage in areas where the standard flood control criteria is not required (Zone C). A Microsoft Excel spreadsheet application calculates the volume of inflow for a range of times and subtracts from that the volume of outflow, assumed to be at a constant rate, over the same time duration. The required storage volume is selected from the cell with the greatest difference between “volume in” minus “volume out.” A factor of safety of 1.25 is applied because this method tends to underestimate the storage volume when compared to pond routing. An example is provided on the following page, and a copy of the spreadsheet is provided with this manual.

4. Flood Control using Retention Basins

The detention function of the Green Calculator can be used to calculate the 25-year storage volume required when retention basins are used to provide flood control. The user-specified release rate would be the infiltration rate provided by the soil over the basin bottom as given the following equation:

$$Q_{out} = i(A)(3600)(12)$$

where:

Q_{out} = Average outflow from basin bottom (cubic feet per second)

i = design infiltration rate of soil (inches per hour)

A = Bottom area of basin (square feet)

3600 = factor to convert hours to seconds

12 = factor to convert inches to feet

The Rational Method spreadsheet may be used in the same manner, with the allowable release rate replaced with the average outflow from the basin bottom.

CAUTION: The Green Calculator assumes that the resulting outflow volume is routed offsite when it is really infiltrated. When the detention function is used in this way, the user must be aware that this volume will be wrongly reflected in the discharge hydrographs.

DETENTION BASIN SIZING
(RATIONAL METHOD)

PROJECT:
JOB NO.:

DATE:
BY:

LOCATION:

CONTRIB. AREA (acres) =
RUNOFF "C" VALUE =
ALLOWABLE CFS/ACRE =
RAINFALL FREQUENCY = 100 YEAR

ALLOWABLE
RELEASE RATE (cfs) = 0

TIME (hrs)	(1) RAINFALL INTENSITY (in/hr)	(2) RAINFALL RUNOFF (cft)	(3) DISCHARGE VOLUME (cft)	(4) STORAGE VOLUME (cft)	(5) STORAGE VOLUME (ac-ft)	(6) TIME TO EMPTY (hrs)
0.17		0	0	0	0.00	0.0
0.25		0	0	0	0.00	0.0
0.33		0	0	0	0.00	0.0
0.5		0	0	0	0.00	0.0
0.67		0	0	0	0.00	0.0
0.75		0	0	0	0.00	0.0
0.83		0	0	0	0.00	0.0
1		0	0	0	0.00	0.0
2		0	0	0	0.00	0.0
3		0	0	0	0.00	0.0
4		0	0	0	0.00	0.0
5		0	0	0	0.00	0.0
6		0	0	0	0.00	0.0
7		0	0	0	0.00	0.0
8		0	0	0	0.00	0.0
9		0	0	0	0.00	0.0
10		0	0	0	0.00	0.0
12		0	0	0	0.00	0.0

NOTES:

- (1) Input rainfall intensity, I, in in/hr for the specified design rainfall at each duration (time, t). $I = P/t$ where P is the rainfall in inches.
- (2) Rainfall runoff volume is calculated by multiplying the Rational Formula, $Q = CIA$, by the time, t : $V = (It)CA$
- (3) Discharge volume is calculated by multiplying the discharge rate by the time: $V_o = Q_o t$
- (4) Storage volume is calculated by subtracting the discharge volume from the runoff volume.
- (5) Storage volume is converted to acre-feet by dividing by 43,560 sft/acre
- (6) Time to empty is calculated by dividing the storage volume by the discharge rate.

5. Water Quality

Treatment of runoff by settling (permanent pool or extended detention), infiltration or filtration is required from directly connected impervious areas and disturbed pervious areas (i.e. lawns). The minimum required water quality volume shall be calculated using the Small Storm Hydrology Method by the following formula:

$$Q = P \times R_v$$

where:

Q = runoff (inches)

P = rainfall (inches)

R_v = area-weighted volumetric runoff coefficient (individual runoff coefficients are given in **Table 11**.)

Table 11 – Runoff Coefficients for Small Storm Hydrology Method

Rainfall, P (inches)	Volumetric Runoff Coefficient, R_v					
	Directly Connected Impervious Area			Disturbed Pervious Area		
	Flat Roofs / Unpaved	Pitched Roofs	Paved	Sandy Soils (HSG A)	Silty Soils (HSG B)	Clayey Soils (HSG C&D)
1.0	0.815	0.965	0.980	0.035	0.120	0.205

Source: Adapted from Table 9.3, *Low Impact Development Manual for Michigan*, SEMCOG, 2008 (Adapted from *The Source Loading and Management Model (WinSLAMM): Introduction and Basic Uses*, R. Pitt, 2003)

and

$$V_{wq} = QA(3630)$$

where:

V_{wq} = minimum required water quality volume (cubic feet)

Q = runoff (inches)

A = contributing area (acres)

3630 = factor to convert acre-inches to cubic feet

If a vegetated filter strip or grassed swale is used, the filtering area must meet minimum standards for slope, length and vegetative cover for a maximum allowable drainage area to filter strip ratio of 6:1.

6. Pre-treatment

- a. Settling Basins (forebay):

$$V_{pt} = 0.15(V_{wq})$$

where:

V_{pt} = minimum required pre-treatment volume (cubic feet)

V_{wq} = water quality volume (cubic feet)

- b. Vegetated Filter Strips:

Provide a 5-foot minimum sheet-flow length at a maximum slope of 2%.

- c. Grassed Swales:

Provide a 15-foot minimum sheet-flow length at a maximum slope of 2%.

- d. Proprietary Treatment Systems:

Follow manufacturer's guidelines.

III. NON-STRUCTURAL BEST MANAGEMENT PRACTICES

MSU has adopted standards for the following non-structural BMPs as defined in Chapter 6 of the *Low Impact Development Manual for Michigan* (SEMCOG 2008):

http://www.semco.org/uploadedfiles/Programs_and_Projects/Water/Stormwater/LID/LID_Manual_chapter6.pdf

- Minimize Soil Compaction and Total Disturbed Area
- Protect Natural Flow Pathways (including Riparian Buffers)
- Protect Sensitive Areas
- Storm Water Disconnection

Design requirements are provided in BMP Fact Sheets from the *Low Impact Development Manual for Michigan* (SEMCOG 2008). All of the following criteria must be met to receive credit for each non-structural BMP selected for use.

Minimize Soil Compaction and Total Disturbed Area

This BMP applies to those portions of buildable lots located outside of construction traffic and staging areas and lot building zones that can be maintained as “minimal disturbance areas” or “no disturbance areas” during construction. This BMP does not require a maintenance plan or permanent easement.

1. Identify “minimal disturbance areas” and “no disturbance areas” on site plan and construction drawings.
2. “Minimal” and “no disturbance” areas must be protected by having the limits delineated/flagged/fenced in the field. Notes to this effect must be included on construction drawings.
3. “No disturbance areas” must not be subject to grading or movement of existing soils. Existing vegetation must be present in a healthy condition. Invasive vegetation may be removed.
4. “Minimal disturbance areas” must not be subject to excessive equipment movement. Vehicle traffic and storage of equipment and/or materials is not permitted.
5. Pruning or other required maintenance of vegetation is permitted. Additional planting with site-appropriate plants, including turf grass is permitted.
6. Areas receiving credit must be located on the development project.

Calculation Credits: Assign a CN reflecting open space in “good” condition, or woods in “fair” condition, instead of open space in “fair” condition as required for disturbed pervious areas. For small sites, individual trees can receive a credit of 800 square feet per tree, counted as woods in “fair” condition. Woods in “good” condition may be used if trees are protected by a local tree ordinance. Exempt from water quality criteria.

Protect Natural Flow Pathways

1. Identify all existing natural flow pathways on site plan.
2. Identify natural flow pathways to be protected on site plan and construction drawings.
3. Natural flow pathways to be protected must have the limits delineated/flagged/fenced in the field. Notes to this effect must be included on construction drawings.
4. Identify flow pathways designed as part of the storm water management system including strategies such as:
 - a. increased length
 - b. increased roughness
 - c. decreased slope
5. Ensure adequacy of flow pathway for post-development flows.
6. Include natural flow pathways in maintenance plan.
7. Protected natural flow paths on multiple individual private lots must have an easement in accordance with the requirements in Part 1 of this manual.

Calculation Credits: Adjust time-of-concentration. Exempt from water quality criteria.

Storm Water Disconnection

1. Storm water from rooftops and other impervious areas is considered disconnected if it is routed to a stabilized vegetated area including onsite swales and bioretention areas, or an onsite depression storage area that meets the following criteria:
 - a. Disconnection must ensure no basement seepage.
 - b. Disconnection in less permeable soils (HSGs C and D) may require the use of dry wells, french drains or other temporary storage device to compensate for poor infiltration capability if ponding of water for extended period of time becomes problematic.
 - c. Maximum contributing impervious area flow path length shall be 75 feet.
 - d. Maximum contributing impervious area shall be 1,000 square feet per discharge point.
 - e. Size of disconnect area shall be twice the size of the contributing impervious area.
 - f. Length of disconnect area must be at least the length of the contributing impervious area.
 - g. Roof downspouts and curb cuts must be at least 10 feet away from the nearest connected impervious surface to discourage “re-connections.”
 - h. Slope of disconnect area must be no greater than 5%.
 - i. Disconnect area must be a “no disturbance” or “minimal disturbance” area.
2. Identify disconnect areas on site plan and construction drawings.
3. Include storm water disconnect areas in maintenance plan.

Calculation Credits: Weight CN with pervious area. Adjust time-of-concentration, including a 1.25 factor for paved areas flowing onto pervious areas. Exempt from water quality criteria.

IV. STRUCTURAL BEST MANAGEMENT PRACTICES

MSU has adopted standards for the following structural BMPs as defined in Chapter 7 of the *Low Impact Development Manual for Michigan* (SEMCOG 2008):

http://www.semco.org/uploadedfiles/Programs_and_Projects/Water/Stormwater/LID/LID_Manual_chapter7.pdf

- Bioretention / Rain Garden
- Capture Reuse
- Constructed Filter
- Detention Basins
- Infiltration Practices
- Level Spreader
- Native Revegetation
- Pervious Pavement
- Planter Box
- Riparian Buffer Restoration
- Soil Restoration
- Vegetated Filter Strip
- Vegetated Roof
- Vegetated Swale / Bioswale
- Water Quality Devices

MSU has also adopted standards for the following additional structural BMPs as defined in this manual:

- Storm Sewer
- Culvert or Bridge
- Spill Containment Cell

BMPs shall be designed in accordance with BMP Fact Sheets from the *Low Impact Development Manual for Michigan* (SEMCOG 2008). Supplemental Design Requirements are provided here. Sizing Calculations and Calculation Credits provided in this manual replace direction given on individual BMP Fact Sheets.

Bioretention / Rain Garden

Supplemental Design Requirements

1. Siting
 - a. Soils investigation is required.
 - b. A minimum of 4 feet is required between the bottom of the BMP and the measured groundwater elevation to account for seasonal and cyclical variations in groundwater level.
2. Materials
 - a. Void ratio for the amended soil material shall be based on the USDA soil textural class and Effective Water Capacity in **Table 7**. A maximum void ratio of 0.30 shall be allowed for the amended soil material.

Sizing Calculations

1. Calculate design runoff volume routed to the BMP.
2. The required storage volume shall be equal to the design runoff volume.
3. The bottom area of the BMP shall be used as the infiltration area.
4. Calculate minimum infiltration area required to drain the required storage volume in the specified drawdown time (72 hours total for BMP, 24 hours for surface ponding) using the design infiltration rate of the soil. (This assumes that the actual infiltration rates of the amended/imported BMP materials are greater than or equal to the design rates allowed based on soil type.)

$$A = [V / (i \times t)] \times 12$$

where:

A = minimum infiltration area (square feet)

V = design runoff volume (cubic feet)

12 = factor to convert inches to feet

i = infiltration rate of soil (inches per hour)

t = maximum allowable drawdown time

5. Calculate the storage volume of the BMP.

$$\text{Average Bed Area (square feet)} = [\text{Area at Design High Water Depth (square feet)} + \text{Bottom Area (square feet)}] / 2$$

$$\text{Surface Storage Volume (cubic feet)} = \text{Average Bed Area (square feet)} \times \text{Design High Water Depth (feet)}$$

$$\text{Subsurface Storage Volume (cubic feet)} = \text{Length (feet)} \times \text{Width (feet)} \times \text{Depth (feet)} \times \text{Void Ratio of Material}$$

$$\text{Total Storage Volume (cubic feet)} = \text{Surface Storage Volume (cubic feet)} + \text{Subsurface Storage Volume (cubic feet)}$$

6. The infiltration volume is counted in the volume credit, and is calculated as:

Design Infiltration Rate (inches per hour) x 6 hours x Infiltration Area (square feet) x 1/12 unit conversion

Note: The infiltration period is the time when the bed is receiving runoff and is capable of infiltrating at the design rate, which is conservatively estimated as 6 hours.

7. For underdrained BMP, follow criteria for filter.

Calculation Credits

Volume Reduction:

- Infiltration: Count storage volume and infiltration volume.
- Underdrained: Count storage and infiltration volume between BMP bottom and elevation of underdrain.

Peak Rate Reduction:

- Reduction in peak discharge due to an extended time of concentration through BMP (storage volume divided by 10-year peak flow rate). The overflow (both rate and volume) is conveyed downstream.

Water Quality:

- Provides through infiltration or filtration.

Capture Reuse

Sizing Calculations

1. Determine water use (gallons per day) and add up for each month of the year.
2. Obtain average monthly precipitation (inches) and evapo-transpiration (ET) in inches. www.enviroweather.msu.edu
3. Multiply average monthly precipitation by contributing area and area-weighted Small Storm Hydrology Method runoff coefficient to obtain volume of recharge. Multiply by 3630 to convert acre-inches to cubic feet. Multiply by 7.48 gallons per cubic foot to convert to gallons.
4. Multiply average monthly ET (inches) by surface area of pond (square feet) and divide by 12 to calculate the volume of water evaporated in cubic feet. Multiply by 7.48 gallons per cubic foot to convert to gallons.
5. Select trial size container or pond volume.
6. Calculate the water balance. A tabular method may be used similar to that illustrated below:

$$\text{Volume of Water in Storage at End of Month} = \text{Storage Volume at Start of Month} + \text{Recharge from Monthly Precipitation} - \text{ET} - \text{Monthly Water Use}$$

Month	Vstart	+Recharge	- ET	- Use	= Vend*	Lost
1						
2	=Vend1					
Total	--				--	

* Limited by total volume of the selected container or pond. If value is greater than container volume, surplus is lost to overflow. If value is negative, it means that amount must be supplemented.

7. Adjust size of container or pond to balance reuse efficiency and cost.

Calculation Credits

Volume Reduction:

- Count storage volume provided.

Peak Rate Reduction:

- Reduction in peak discharge due to an extended time of concentration through BMP (storage volume divided by 10-year peak flow rate). Outflow (rate and volume) conveyed downstream.

Water Quality:

- Provides through ultimate infiltration (irrigation), or discharge to wastewater system.

Constructed Filter

Supplemental Design Requirements

1. Siting
 - a. Soils investigation is required.
 - b. A minimum of 2 feet is required between the bottom of the BMP and the measured groundwater elevation to account for seasonal and cyclical variations in groundwater level.

Sizing Calculations

2. Calculate design runoff volume routed to the BMP.
3. Calculate filter surface area required to drain the design volume in the specified drawdown time (72 hours total for BMP; 24 hours for surface ponding) using design infiltration rate of filter media.

$$A = [V \times d_f / (i \times (h_f + d_f) \times t)] \times 12$$

where:

A = minimum surface area of filter (square feet)

V = design runoff volume (cubic feet)

d_f = depth of filter media (1.5-foot minimum to 2.5-foot maximum)

i = infiltration rate of soil (inches per hour)

h_f = average head; typically $\frac{1}{2}$ of the maximum head on filter media (feet)

t = maximum allowable drawdown time

12 = factor to convert inches to feet

3. Check whether soil conductivity or hydraulics of underdrain governs.

Calculation Credits

Volume Reduction:

- None given.

Peak Rate Reduction:

- Reduction in peak discharge calculated by routing through BMP; outflow (rate and volume) conveyed downstream.

Water Quality:

- Provides through filtration.

Detention Basins

Supplemental Design Requirements

1. Siting
 - a. Soils investigation is required.
2. Sizing and Configuration
 - a. The bottom of dry detention basins shall be graded to provide positive flow to the pipe outlet. A minimum flow line bottom slope of 1% should be provided. Cross slopes should be 2% minimum. If continuous flow is anticipated, a low-flow channel shall be provided, with necessary crossings, and sloped to eliminate standing water.
 - b. At a minimum, the volume of the permanent pool for wet detention basins shall be 2.5 times the water quality volume.
 - c. Where water quality and stream protection are provided through detention, these volumes may be included in the flood control volume.
3. Outlet Design
 - a. The outlet may be designed using the orifice equation, rearranged to solve for area.

$$A = \frac{Q}{c \sqrt{2gH}}$$

where:

A = required area (square feet)

Q = required outflow (cubic feet per second)

c = orifice coefficient (approximately 0.6)

2g = two times the gravitation constant (g = 32.2 feet per second)

H = height of design high water level above center of orifice outlet (feet)

- b. Other types of outlet devices shall have full design calculations provided for review.
- c. Pipes or orifice plates shall have a minimum diameter of 4 inches.
- d. Riser pipes with holes or slits less than 4 inches in diameter shall have a stone and gravel filter placed around the outside of the pipe.
- e. Hoods and trash racks shall be placed on riser pipes. Grate openings shall be a maximum of 3 inches on center.
- f. Riser pipes shall have a minimum diameter of 24 inches. Riser pipes greater than 4 feet in height shall be 48 inches in diameter.

- g. Riser pipes shall be constructed of reinforced concrete or corrugated metal and be set in a concrete base. Plastic is not acceptable as a riser material.
- h. Outlet control structures shall be placed near or within the embankment to facilitate maintenance access.
- i. All detention facilities must have a provision for overflow at the high water level. A spillway shall be designed for the 10-year inflow with a maximum flow depth of 1 foot. The spillway shall be sized using the weir equation.

$$Q = 2.6LH^{\frac{3}{2}}$$

where:

Q = discharge (cubic feet per second)

2.6 = coefficient of discharge

L = length of spillway crest (feet)

H = total head measured above spillway crest (feet)

- j. The top of berm elevation shall be a minimum of 1 foot above the design maximum water level.
 - k. Overflow spillways shall be protected with riprap or a permanent erosion control blanket to prevent erosion of the structure.
4. Sediment Forebay
- a. The capacity of the forebay shall be equivalent to the pretreatment volume. Where more than one inlet pipe is required, the calculated forebay volume shall be pro-rated by flow contribution of each inlet.
 - b. The length-to-width ratio shall be a minimum of 1.5:1 and a maximum of 4:1.

Sizing Calculations

1. Calculate required design runoff volume and peak rate (inflow hydrograph).
2. Calculate allowable outflow(s).
3. Route inflow hydrograph through detention pond using stage-storage relation and outlet hydraulics. Storage volume may be calculated by:
 - a. Green Calculator
 - b. Rational Method Spreadsheet
 - c. Other Computer Routing Program

Calculation Credits

Volume Reduction:

- None given

Peak Rate Reduction:

- Reduction in peak discharge calculated by routing through BMP; outflow (rate and volume) conveyed downstream

Water Quality:

- Dry Pond: Does not provide sufficient treatment
- Wet Pond: Provides through permanent pool
- Underground Detention: Does not provide sufficient treatment
- Constructed Wetlands: Provides through permanent pool
- Extended Detention: Provides through sufficient particle settling time

Infiltration Practices

Supplemental Design Requirements

1. Siting
 - a. Soils investigation is required.
 - b. A minimum of 4 feet is required between the bottom of the BMP and the measured groundwater elevation to account for seasonal and cyclical variations in groundwater level.
2. Sizing and Configuration
 - a. Infiltration basins with a permanent water level shall be sized based on the horizontal projection of the side slopes above the permanent water elevation to calculate the required infiltration area.
 - b. Infiltration basins without an acceptable surface water overflow route shall include a factor of safety of an additional 3 feet of freeboard.

Sizing Calculations

1. Dry wells, leaching basins, infiltration trenches, infiltration beds, infiltration berms:
 - a. Calculate design runoff volume routed to the BMP.
 - b. The required storage volume shall be equal to the design runoff volume.
 - c. Infiltration area shall be defined as:

BMP	Infiltration Area
Dry Well/Leaching Basin	Bottom and sides (lateral)
Infiltration Trench	Bottom of trench (length x width)
Infiltration Bed	Bottom area of the bed
Infiltration Berm	Ponding area (length of berm x average width of ponding behind berm)
 - d. Calculate the minimum infiltration area required to drain the required storage volume in the specified drawdown time (72 hours total for BMP) using the design infiltration rate of the soil.

$$A = [V / (i \times t)] \times 12$$

where:

A = minimum infiltration area (square feet)

V = design runoff volume (cubic feet)

12 = factor to convert inches to feet

i = infiltration rate of soil (inches per hour)

t = maximum allowable drawdown time

e. Calculate the storage volume of the BMP.

(1) Dry wells, infiltration trenches, infiltration beds:

Subsurface Storage Volume (cubic feet) = Length (feet) x Width (feet) x Depth (feet) x Void Ratio of Material

(2) Leaching basins:

Storage Volume (cubic feet) = $2 \Pi r^2$ (square feet) x Depth (feet)

where:

r = radius of leaching basin (feet)

Π = pi (approximately 3.14)

(3) Infiltration berm:

Surface Storage Volume (cubic feet) = Ponding Area (square feet) x Design High Water Depth (feet)

f. The infiltration volume is counted in the volume credit, and is calculated as:

Design Infiltration Rate (inches per hour) x 6 hours x Infiltration Area (square feet) x 1/12 unit conversion

Note: The infiltration period is the time when the bed is receiving runoff and is capable of infiltrating at the design rate, which is conservatively estimated as 6 hours.

2. Infiltration basins:

a. Calculate required design runoff volume and peak rate (inflow hydrograph).

b. The infiltration area shall be defined as the bottom of the basin.

c. Calculate minimum infiltration area required to drain design volume in specified drawdown time (72 hours for surface ponding) using estimated design infiltration rate of soil.

$$A = [V / (i \times t)] \times 12$$

where:

A = minimum infiltration area (square feet)

V = design runoff volume (cubic feet)

12 = factor to convert inches to feet

i = infiltration rate of soil (inches per hour)

t = maximum allowable drawdown time

d. Calculate storage volume based on minimum allowable infiltration area and allowable depths. Storage volume may be calculated by:

- (1) Green Calculator
- (2) Rational Method Spreadsheet
- (3) Other Computer Routing Program

Calculation Credits

Volume Reduction:

- Count storage volume and infiltration volume.

Peak Rate Reduction:

- Reduction in peak discharge due to an extended time of concentration through BMP (storage volume divided by 10-year peak flow rate).

Water Quality:

- Provides through infiltration.

Level Spreaders

Calculation Credits

Volume Retained:

- None given

Peak Rate Reduction:

- None given

Water Quality:

- Does not provide sufficient treatment

Native Revegetation

1. Identify native revegetation areas on site plan and construction drawings.
2. Native revegetation areas must be protected by having the limits delineated/flagged/fenced in the field. Notes to this effect must be included on construction drawings.
3. Areas receiving credit must be located on the development project.
4. Include native revegetation areas in maintenance plan.

Calculation Credits: Assign a CN reflecting a meadow instead of open space in “fair” condition as required for other disturbed pervious areas. For small sites, individual trees can receive a credit of 200 square feet per tree, counted as woods in “good” condition. Exempt from water quality criteria.

Pervious Pavement

Supplemental Design Requirements

1. Siting
 - a. Soils investigation is required.
 - b. A minimum of 4 feet is required between the bottom of the BMP and the measured groundwater elevation to account for seasonal and cyclical variations in groundwater level.
 - c. Runoff from offsite areas shall not be directed onto porous pavement surface.

Sizing Calculations

1. Calculate required design rainfall volume.
2. The required storage volume shall be equal to the design rainfall volume from the contributing surface area (porous pavement, roof).
3. The bottom area of the BMP shall be used as the infiltration area.
4. Maximum allowable drawdown time shall be 72 hours.
5. Calculate the subsurface storage volume of the BMP.

$$\text{Subsurface Storage Volume (cubic feet)} = \text{Length (feet)} \times \text{Width (feet)} \times \text{Depth (feet)} \times \text{Void Ratio of Material}$$

6. The infiltration volume is counted in the volume credit, and is calculated as:

$$\text{Design Infiltration Rate (inches per hour)} \times 6 \text{ hours} \times \text{Infiltration Area (square feet)} \times 1/12 \text{ unit conversion}$$

Note: The infiltration period is the time when the bed is receiving runoff and is capable of infiltrating at the design rate, which is conservatively estimated as 6 hours.

7. For underdrained BMP, follow criteria for filter.

Calculation Credits

Volume Reduction:

- Infiltration: Count storage volume and infiltration volume limited by 2-year rainfall volume on pavement.

Peak Rate Reduction:

- Reduction in peak discharge due to an extended time of concentration through BMP (storage volume divided by 10-year peak flow rate). The overflow (both rate and volume) is conveyed downstream.

Water Quality:

- Provides through infiltration or filtration.

Planter Box

Supplemental Design Requirements

1. Siting
 - a. Soil infiltration testing is required.
 - b. A minimum of 4 feet is required between the bottom of the BMP and the measured groundwater elevation to account for seasonal and cyclical variations in groundwater level.
2. Materials
 - a. Void ratio for the amended soil material shall be based on the USDA soil textural class and Effective Water Capacity in **Table 7**. A maximum void ratio of 0.30 shall be allowed for the amended soil material.

Sizing Calculations

1. Calculate design runoff volume routed to BMP.
2. The required storage volume shall be equal to the design runoff volume.
3. The bottom area of the BMP shall be used as the infiltration area.
4. Calculate minimum infiltration area required to drain the required storage volume in specified drawdown time (12 hours total for BMP; 4 hours for surface ponding) using the design infiltration rate of the soil. (This assumes that the actual infiltration rates of the amended/imported BMP materials are greater than or equal to the design rates allowed based on soil type.)

$$A = [V / (i \times t)] \times 12$$

where:

A = minimum infiltration area (square feet)

V = design runoff volume (cubic feet)

12 = factor to convert inches to feet

i = infiltration rate of soil (inches per hour)

t = maximum allowable drawdown time

5. Calculate the storage volume of the BMP.

Surface Storage Volume (cubic feet) = Bed Area (square feet) x Design High Water Depth (feet)

Subsurface Storage Volume (cubic feet) = Length (feet) x Width (feet) x Depth (feet) x Void Ratio of Material

Total Storage Volume (cubic feet) = Surface Storage Volume (cubic feet) + Subsurface Storage Volume (cubic feet)

6. The infiltration volume is counted in the volume credit, and is calculated as:

Design Infiltration Rate (inches per hour) x 6 hours x Infiltration Area (square feet) x 1/12 unit conversion

Note: The infiltration period is the time when the bed is receiving runoff and is capable of infiltrating at the design rate, which is conservatively estimated as 6 hours.

7. For underdrained BMP, follow criteria for filter.

Calculation Credits

Volume Reduction:

- Infiltration: Count storage volume and infiltration volume.
- Filtration: None given.

Peak Rate Reduction:

- Reduction in peak discharge due to an extended time of concentration through BMP (storage volume divided by 10-year peak flow rate). The overflow (both rate and volume) is conveyed downstream.

Water Quality:

- Provides through infiltration or filtration.

Soil Restoration

This BMP includes soil amendment and/or deep tilling to restore porosity to compacted soils and infiltration beds of other BMPs. However, due to the difficulty of ensuring implementation and longevity, this BMP provides no storm water credit.

Vegetated Filter Strip

Sizing Calculations

1. Calculate area contributing runoff.
2. Calculate minimum required filter strip area.
3. Calculate minimum required length based on slope and type of vegetation.

Calculation Credits

Volume Reduction:

- None given.

Peak Rate Reduction:

- Adjust time-of-concentration.

Water Quality:

- Provides through infiltration or filtration.

Vegetated Roof

Sizing Calculations

1. Calculate the subsurface storage volume of the BMP.

$$\text{Subsurface Storage Volume (cubic feet)} = \text{Length (feet)} \times \text{Width (feet)} \times \text{Depth (feet)} \times \text{Void Ratio of Material}$$

Calculation Credits

Volume Reduction:

- Count storage volume limited by 2-year rainfall volume on roof.

Peak Rate Reduction:

- Reduction in peak discharge due to an extended time of concentration through BMP (storage volume divided by 10-year peak flow rate). Outflow (rate and volume) conveyed downstream.

Water Quality:

- Exempt from water quality criteria.

Vegetated Swale / Bioswale

Sizing Calculations

1. Channel
 - a. Calculate 10-year peak flow rate.
 - b. Size channel based on Manning's Equation.
 - c. Check that flow velocities are within acceptable limits.
2. Volume Behind Check Dam

Calculate the wedge-shaped storage volume behind each check dam.

Storage Volume (cubic feet) = 0.5 x Length of Swale Impoundment Area per Check Dam (feet) x Depth of Check Dam (feet) x [Top Width of Check Dam (feet) + Bottom Width of Check Dam (feet)] / 2

Calculation Credits

Volume Reduction:

- Vegetated Swale: None given
- Bioswale: Storage volume behind check dams.

Peak Rate Reduction:

- Adjust time-of-concentration.

Water Quality:

- Provides through infiltration or filtration of runoff if vegetated filter strip area, length and slope requirements are met.

Water Quality Device

Calculation Credits

Volume Reduction:

- None given.

Peak Rate Reduction:

- None given.

Water Quality:

- Does not provide sufficient treatment.

Storm Sewer

Design Requirements

1. Sizing and Configuration

- a. The storm sewer system shall be designed to convey runoff from a 10-year frequency rainfall event.
- b. Storm sewer design velocities, capacities, and friction losses shall be based on Manning's equation:

$$Q = \frac{1.49AR^2S^{\frac{1}{2}}}{n}$$

where:

Q = discharge (cubic feet per second)

A = wetted area (square feet)

R = hydraulic radius (feet)

S = slope (feet per foot)

N = Manning's Coefficient

- c. Acceptable slopes for circular pipe ("n" = 0.013) are included in **Table 12**. Minimum and maximum grade for other Manning's n values must be calculated based on allowable minimum and maximum velocities (V).

Table 12- Minimum and Maximum Slopes for Storm Sewers
(Manning's "n" = 0.013)

Pipe Size	Minimum % of Grade (V = 2.5 feet/second)	Maximum % of Grade (V = 10 feet/second)
12"	0.32	4.88
15"	0.24	3.62
18"	0.20	2.84
21"	0.16	2.30
24"	0.14	1.94
27"	0.12	1.66
30"	0.10	1.44
36"	0.08	1.12
42"	0.06	0.92
48"	0.06	0.76
54"	0.04	0.60
60"	0.04	0.54
66"	0.04	0.48

- d. Manning's coefficients for closed conduit are included **Table 13**.

Table 13 - Manning's Roughness Coefficients

Conduit	Manning's Coefficients
Closed Conduits	
Asbestos-Cement Pipe	0.011 to 0.015
Brick	0.013 to 0.017
Cast Iron Pipe Cement-lined and seal-coated	0.011 to 0.015
Concrete (Monolithic) Smooth forms	0.012 to 0.014
Rough forms	0.015 to 0.017
Concrete Pipe	0.011 to 0.015
Corrugated-Metal Pipe (1/2-inch corr.) Plain	0.022 to 0.026
Paved invert	0.018 to 0.022
Spun asphalt-lined	0.011 to 0.015
Plastic Pipe (Smooth)	0.011 to 0.015
Vitrified Clay Pipes	0.011 to 0.015
Liner channels	0.013 to 0.017
Open Channels	
Lined Channels Asphalt	0.013 to 0.017
Brick	0.012 to 0.018
Concrete	0.011 to 0.020
Rubble or riprap	0.020 to 0.035
Vegetal	0.030 to 0.040
Excavated or Dredged Earth, straight and uniform	0.020 to 0.030
Earth, winding, fairly uniform	0.025 to 0.040
Rock	0.030 to 0.045
Unmaintained	0.050 to 0.140
Natural Channels (minor streams, top width at flood state < 100 feet) Fairly regular section	0.030 to 0.070
Irregular section with pools	0.040 to 0.100

Source: *Design and Construction of Sanitary and Storm Sewers*, American Society of Civil Engineers and the Water Pollution Control Federation, 1969.

- e. As a general rule, surcharging the pipe will be allowed to 1 foot below the top of casting. However, minor losses must be considered in hydraulic grade line calculations.
- f. Storm sewer pipe shall have a minimum diameter of 12 inches.
- g. The minimum depth of cover shall be 24 inches from grade to the top of pipe.
- h. Restricted conveyance systems designed to create backflow into storm water storage facilities are not permitted.

2. End Treatment

Outlet protection shall be provided as necessary to prevent erosion, based on the maximum velocities specified under the Open Channel BMP.

3. Manholes and Catchbasins

- a. Manhole spacing shall not exceed 400 feet for sewers less than 42 inches in diameter and 600 feet for larger sewers.
- b. Manholes shall be placed at all changes in pipe direction, pipe size, all inlet connection locations, and at the end of the storm sewer.
- c. Pipe inverts at junctions shall be designed to minimize junction losses (match 0.8 points of pipe diameters).
- d. Minimum inside diameter of all manholes, catch basins, and inlet structures shall be 48 inches.
- e. Inlet structures shall be placed at low points of streets and yards, and be spaced a maximum of 400 feet apart. Spacing and/or number of inlet structures required to accommodate the design flows in streets, private drives, and parking areas shall be provided based on inlet capacity with no ponding occurring during a 10-year storm.
- f. No more than 150 feet of street drainage will be allowed to flow around a corner.
- g. No flow will be allowed across a street intersection.
- h. Perforated catchbasins (leaching basins) shall have an open bottom and perforations around the circumference of the structure at no greater than 12-inch intervals horizontally and vertically the entire depth of the sump.

4. Materials

- a. Storm sewer pipe shall be reinforced concrete or smooth interior wall polyethylene in accordance with MDOT Standard Specifications.
- b. Pipe joints shall be designed to prevent excessive infiltration or exfiltration.
- c. Manholes and catch basins shall be in accordance with MDOT Standard Specifications.
- d. Connections to manholes shall be made with a resilient connector for pipe diameters 24 inches or less.

Calculation Credits

Volume Reduction:

- Solid wall pipe: None given.
- Perforated pipe (meeting slopes for minimum velocity): None given.
- Perforated catchbasins (leaching basins): Count storage volume below outlet pipe invert.

Peak Rate Reduction:

- None given.

Water Quality:

- Does not provide sufficient treatment.

Spill Containment Cell

Design Requirements

1. General
 - a. A spill containment cell or equivalent storm water filter shall be used to trap and localize incoming sediments, and to capture slug pollutant loads from accidental spills of toxic materials (spill containment volume).
 - b. The spill containment cell can be a wet forebay or an under-drained storm water filter with an impermeable bottom and sides to the design high water level.
2. Sizing and Configuration
 - a. The spill containment cell volume shall be equivalent to the pre-treatment volume.
 - b. The minimum surface area shall be 25% of the required volume.
 - c. The length-to-width ratio for wet forebays shall be a minimum of 3:1, and a maximum of 4:1 to allow for adequate hydraulic length, yet minimize scour velocities. The maximum length-to-width ratio for storm water filters may be as high as 20:1 to allow for incorporation into a swale.
 - d. The minimum hydraulic length shall be equal to the length specified in the length-to-width ratio.
 - e. The overflow structure from the spill containment cell shall be sized for the peak inflow from a 10-year rainfall event.
 - f. The top-of-berm elevation between the spill containment cell and the downstream receiving BMP shall be a minimum of 1 foot below the outer berm elevation.
 - g. The spill containment cell shall have a minimum 1-foot-deep sump below the inlet pipe for sediment accumulation.
 - h. The outlet structure from a wet forebay shall be designed to draw water from the central portion of the water column within the cell to trap floatables and contain sediments. The inlet side of the structure shall be located a minimum of 1 foot below the normal water level, and a minimum of 1.5 feet from the bottom of the spill containment cell. Minimum depth of the permanent pool is 2.5 feet. The outlet structure from a storm water filter shall be designed within a manhole and be designed to draw water from the central portion of the water column to trap floatables and contain sediments in a sump.

3. Materials

The spill containment cell shall be lined with impermeable materials extending up to the design high water elevation. A minimum 18-inch-thick clay later, or an impermeable liner protected with a minimum 12 inches of soil cover are acceptable alternatives. Maximum allowable permeability shall be 1×10^{-7} centimeters per second as determined by the geotechnical consultant for clay placement, or manufacturer's certificate for liner products.

Calculation Credits

Volume Reduction:

- None given.

Peak Rate Reduction:

- None given.

Water Quality:

Used for pre-treatment, but could be sized to meet water quality volume standards

<u>TABLE OF CONTENTS</u>	<u>1</u>
--------------------------	----------

<u>ELECTRICAL</u>	<u>2</u>
-------------------	----------

- Summary
- Sustainability
- Electrical Distribution
- Lighting
- Detection and Alarm
- Communication Systems
- Lightning Protection
- Clock Systems
- Access Control
- Housekeeping Pad

ELECTRICAL DESIGN

1. SUMMARY

- A. This section contains information which serves as general requirements for electrical design.
- B. Refer to applicable codes and standards for further information on the criteria mentioned in this section.
- C. Refer to SPACE ALLOCATIONS AND DESCRIPTIONS in Design Guidelines - General for electrical space requirements and to appropriate sections MSU Construction Standards for additional design considerations.
- D. Departmental equipment requiring access by department personnel shall not be located in building electrical rooms or transformer vaults in order to maintain electrical room and transformer vault security.

2. SUSTAINABILITY AND LEED™

- A. The performance standard, LEED™ v3.0, shall be implemented to the extent feasible and practicable in all new buildings and major renovation projects in existing buildings. Refer to LEED™ in Design Guidelines – General Section for more information.

3. DESIGN PROCESS

A. System Voltage

- MSU's main distribution service is at 13,200 volts with two radial feeders forming a primary selective system. Both cables are energized continuously with an automatic transfer switch at each building to transfer that building in case of power failure.
- New facilities are to be served by the 13,200 volt primary selective system with each cable having a momentary symmetrical short circuit capacity of approximately 679MVA (X/R=52) at the T.B. Simon Power Plant.
- All new cable shall be rated 15,000 volts.
- Primary voltage to all new buildings shall be 13,200 volts delta. When major alterations or additions are made to buildings presently fed by the 4,160 volt system, they shall be upgraded to the 13,200 volt system.
- In all areas of the campus, (except outlying areas, farms, etc.), all primary, secondary, and communication cables will be installed in ducts with vaults at each change in direction.
- Incoming primary shall be two minimum size 2/0 AWG, 15,000 volt, three single conductor cables terminated with Class 1 Outdoor terminations on a selector switch unit.

B. Building Primary Service

- The building electrical service shall consist of primary switches with source transfer control in a common-bus-primary-selective configuration feeding a load break primary switch for each transformer on each of the double ended substation(s).
- The double ended substation shall have a full rated tie breaker and 25% spare minimum 600 amp feeder breakers in fully bussed and equipped compartments. All spare breaker compartments shall be completely bused and equipped for use by minimum 600 amp breakers. When emergency lighting or critical loads are connected to the substation, automatic transfer controls and breakers connected ahead of the main breakers shall be used.
- All primary switch units and unit substations shall be mounted on leveling channels in 4 inch concrete bases with angle iron or channel nosing.
- The arrangement of the primary switches, unit substations, and all other equipment in the transformer vault shall be such as to provide ample maintenance room and such that any piece of equipment can be removed without removing other pieces of equipment.

C. Transformer Vault

- Provide a six inch concrete curb across doorway.
- Installation of doors and locks on transformer room shall be required prior to energizing equipment. See Finish Hardware for type of lock.
- Provide a floor drain in transformer vault, if possible.
- Provide thermostatically operated louvers in areaway ventilator with frame for supporting inexpensive throwaway type pre-filters.
- Provide an Ethernet connection in the main metering compartment of one of the electrical substations. Ethernet shall be housed in a 3/4 inch conduit from the metering compartment to the wall of the Transformer Vault and then routed via conduit and communications cable tray to the Broadband Utility Room for network access outside of the building firewall.
- Provide a 1/4 inch x 2 inch copper ground bus around the perimeter of the vault including going around door and areaway openings.

D. Primary Switch Units

- The metal clad primary switch unit shall consist of two 15 kV primary selector switches with source transfer control for the incoming feeders and 15 kV fused transformer primary switches.
- The switch unit shall be front accessible only, capable of being installed back against a wall.
- Unit shall be free standing, consisting of cubicles arranged for bolting together in the electrical room. Cubicles shall be welded, reinforced sheet steel enclosures with hinged doors. Complete unit shall be rust proofed and painted two coats.
- Primary switches and source transfer control unit shall be mounted in one combination unit consisting of two cubicles.

- Interior barriers shall be provided to form a low voltage compartment completely isolated from the high voltage compartments.

E. Building Secondary Service

- In general, distribution is from drawout circuit breakers in the unit substation to fused or circuit breaker distribution panels to plug-in circuit breaker branch panels.
- Unit Substation
 - ◇ Unit substations shall be double ended, with main secondary breakers and tie breaker to allow manual transfer of load to keep building in service while maintenance is performed on transformer or 13,200 volt switch and fuse compartment.
 - ◇ Maximum size of any transformer shall be 2,000 KVA.
 - ◇ If the lighting load and power load is heavy and motors are fairly large, building service should be 277/480 volts using dry transformers to supply 120/208 volts for duplex receptacles and other 120/208 volt loads.
 - ◇ If the lighting load is heavy compared to the power load and no large motors are required, the building secondary service should be 120/208 volts.
 - ◇ When the total electric load in the building is 200 KVA or more, install two double ended unit substations, one for equipment at 120/208 volts and one for light and power at 277/480 volts.
 - ◇ Install a 3/4 inch conduit from each metering compartment to one of the metering compartments (named Main Metering Compartment) to network the watt-hour meters.

F. Voltage Drop

- The combined voltage drop of secondary feeders and branch circuits should not exceed 3% of the service voltage.

G. Arc Flash

- The electrical system shall be designed so that the Arc Flash Hazard at any point does not exceed Level 2.
- An arc flash analysis shall be performed on the completed system. The results shall be turned over to the Owner for the installation of appropriate labels.

H. Overcurrent Coordination

- A preliminary overcurrent coordination study shall be performed on the designed system to assure that overcurrent coordination is achieved throughout the system. This study will be used to determine the initial overcurrent settings of protective devices.
- A final overcurrent coordination study shall be performed on the installed system to assure that overcurrent coordination is achieved with the installed protective devices. This study will be used to determine the final overcurrent settings of protective devices.

I. Power Factor

- The power factor should not be less than 90%.

J. Emergency Power System

- A natural gas engine driven emergency generator shall be installed to feed emergency lights, EXIT lights, fire alarm system, basic telephone communications, one elevator serving all floors, Broadband Utility and Telephone Utility Rooms, Central Control system cabinets and communications, and other designated critical loads in the event electrical power to the building fails.
- The generator control shall also be interfaced with any feeders feeding auditorium or large assembly areas to sense any loss of voltage. Upon voltage loss, the generator will feed emergency lights in the Auditorium/Assembly area.
- The generator room outside air intake shall have thermostatically operated louvers with a frame for supporting inexpensive throwaway type pre-filters. Pre-filters shall be provided with the frame.

K. Low-Voltage Distribution

- ◇ Distribution Panels
 - ◇ In general, all power and lighting distribution panels shall be either switch and fuse type or circuit breaker if the circuits are 200 amps or smaller. For circuits larger than 200 amps, use circuit breaker type panel. Bus shall be copper. Each branch circuit panel and motor circuit shall be fused separately. On motor circuits, the size of the switch and fuse shall be based on using Fusetrans Class "R".
 - ◇ Distribution panels shall be installed in the electrical switch room, mechanical room, or other accessible location. These panels shall not be installed in plenum chambers. The panel areas should be adequately ventilated.
- ◇ Lighting Panels
 - ◇ Branch circuit panels shall be installed in electrical switch rooms, mechanical rooms, corridors, or other accessible locations. These panels shall not be installed in plenum chambers, doorways, or custodial closets.
- If panels are in electric closet, door to closet should have a name plate.
 - ◇ Motors
 - ◇ Motors located remote from the combination starters should have a disconnect in the power feeders, not a lock-out stop in the control circuit.
 - ◇ Conventional combination motor starters shall be furnished by the Electrical Contractor for all equipment including that furnished by the Mechanical Contractor.
 - ◇ When supply and exhaust fans compose a system, the controls of paired supply and exhaust fans shall be arranged so that the exhaust fan shall start when the supply fan starts.
 - ◇ Special controls such as alternators on duplex pumps, pressure switches, etc., shall be furnished by the Contractor furnishing the equipment.

- ◇ Where motors are grouped reasonably close together, motor control centers should be used.
- ◇ Fire stats or smoke detectors should be connected into the motor control circuit in a manner that will not permit the motor to run when the device has been activated. This applies to hand as well as automatic position of selector switch. Pilot lights shall be installed in a convenient location to show when interlocked fire stats have tripped the motor control circuit.

L. Circuiting

- In general all lighting branch circuits shall be separate from power and receptacle branch circuits.
- A shared neutral between branch circuits shall not be used for single phase, phase-to-neutral loads at either 120 volts or 277 volts.
- Light Switches
 - ◇ Three-way switches shall not be used in individual offices; use a single pole switch at the corridor entrance.
 - ◇ In large rooms with two or more doors to the corridor, use single pole, 3-way or 4-way switches as the use of the room dictates.
 - ◇ In classrooms, laboratories, conference rooms, office areas, or other large rooms with 3- or 4-lamp fluorescent fixtures, arrange switches so that 2 outer lamps in each fixture are on one switch and the remaining lamps are on another switch. If fixtures are 2-lamp, switch alternate fixtures. Locate the switch controlling the two outer lamps nearest the door.
 - ◇ In corridors, connect alternate fixtures to one switch and connect the remaining fixtures to a key switch. Keep total number of switches as low as practical.
- Receptacles
 - ◇ In general, only five to six receptacles should be installed on a 20 ampere circuit. This will allow for load growth and installing additional receptacles in the future.
 - ◇ For corridor receptacles, a maximum of two receptacles shall be installed on a 20 ampere circuit.
 - ◇ Receptacles located in toilet rooms, bathrooms, kitchens, wet laboratory benches, in general around wet and/or damp areas shall be GFCI type.
 - ◇ Install one duplex receptacle in each toilet room for an electric hand dryer. The mounting height of the outlet will depend on the intended use of the hand dryer.
 - ◇ In general there shall be two duplex receptacles located side-by-side (to form a quad outlet) at the desk location in offices.
 - ◇ Convenience outlets and special purpose outlets will normally be flush in the walls.
 - ◇ Floor outlets or under floor duct are used only in large office or secretarial areas where service is not practical using wall outlets. Their use is discouraged.
- Cover Plates

- ◇ Switch and receptacle plates in laboratories shall be non-ferrous stainless steel.
- ◇ Switch and receptacle plates for Residential and Hospitality Services residence hall buildings and in corrosion areas such as chemical laboratories, water treatment areas, etc. shall be Leviton unbreakable nylon, color brown.

4. LIGHTING

A. Interior

- General

- ◇ Lighting levels shall be kept to the minimum acceptable for the use intended. Designers must keep in mind that excessive lighting levels are doubly detrimental. Not only do they use inordinate amounts of energy, but due to their visibility, also create a poor public image for MSU.
 - ◇ Electrical consumption can be reduced by installing lighting which provides the lowest acceptable illumination level for the expected room activity. By using less electricity for lighting, less heat is emitted, thereby reducing the cooling load.
 - ◇ Fluorescent lights shall be used wherever practical.
 - ◇ For high ceiling areas, fluorescent, metal halide, and/or high pressure sodium lighting should be evaluated and the most appropriate system utilized. Noise criteria of 30 shall be maintained when using HID lighting.
 - ◇ When dimming is required for video projection, incandescent lamps shall be used. The incandescent system shall be installed along with a fluorescent system and shall only be designed to meet the video projection requirements. The fluorescent system shall be used for normal illumination.
 - ◇ In general, light fixtures shall be mounted such that they can be maintained from an 8' to 10' step ladder.
 - ◇ All fluorescent tubes shall be F32, 32 watt, rapid start T8, 4100 degree Kelvin unless some special application makes this impractical.
 - ◇ There shall be at least one switch for each room. Rooms with more than one means of entrance or egress will have switches at each door.
 - ◇ Areas which utilize three or four lamp fluorescent fixtures shall be double switched. The two outer lamps shall be switched from the switch nearest the door to the area, and the inner lamp(s) shall be switched from the second switch.
 - ◇ In general, specification grade fluorescent fixtures shall be 2' x 4' flush troffers or surface mounted, metal enclosed, modular fixtures. Lenses shall be flat in hinged metal frames and normally will be prismatic, transparent, .125" thick, acrylic plastic. Do not use fixtures with wrap around lenses.
- Light Pollution Reduction
 - ◇ Light trespass shall be eliminated from the building and site to improve night sky access and reduce development impact on nocturnal environments.
 - ◇ Comply with the LEED™ standard as required in the LEED™ section of the Design Guidelines – General.

- Controllability of Systems, Lighting
 - ◇ Provide a high level of lighting system control by individual occupants or specific groups in multi-occupant spaces such as classrooms and conference areas to promote productivity, comfort and well being of building occupants.
 - ◇ Design individual lighting system controls for 90% of occupants to enable lighting adjustments to suit individual task needs and preferences.
 - ◇ Plan for lighting controls for multi-occupant spaces such as classrooms and conference areas to enable lighting adjustment that meets group needs and preferences.
 - ◇ Comply with the LEED™ standard as required in the LEED™ section of the Design Guidelines – General.
- Lighting Levels
 - ◇ Interior average lighting levels recommended by MSU:
 - a. Offices, classrooms, laboratories 50 F.C.
 - b. Corridors, lobbies, stairs toilets 15 F.C.
 - c. Storerooms and electrical and mechanical spaces 10 F.C.
 - d. Electronic control equipment in mechanical and electrical spaces, including both sides of the elevator machine space 50 F.C.
- Emergency Lighting
 - ◇ Emergency lighting shall be the corridor fluorescent night light system. Emergency lights shall also be installed in the transformer vault, main mechanical room, receiving room, auditoriums, theaters, large lecture halls, and dining rooms. These same lights shall be utilized as night lights.
 - ◇ Emergency lighting in spaces other than corridors, lobbies, and stairwells shall utilize a ballast-load-transfer-control unit to allow the lights to be turned off when the space is not occupied.
 - ◇ Exit lights will be connected to the emergency lighting system. These lights will be continuously illuminated.
- EXIT Lights
 - ◇ Exit lights shall be installed in accordance with the National Electric Codes and the recommendation of the MSU Public Safety Department.
 - ◇ Letters and direction arrows shall be green. In all situations, the signs shall be continuously illuminated. The power shall come from the building emergency power source - EXIT light circuit/emergency generator.

B. Exterior

- Exterior lighting shall be high pressure sodium.
- Light Pollution Reduction
 - ◇ Light trespass shall be eliminated from the building and site to improve night sky access and reduce development impact on nocturnal environments.

- ◇ Comply with the LEED™ standard as required in the LEED™ section of the Design Guidelines – General.
- Lighting Levels
 - ◇ Exterior average lighting levels recommended by MSU:
 - a. Building entrances, active parking and walkway areas 1/2 F.C.
 - b. Inactive parking, walkway areas, and roadways 1/3 F.C.
 - ◇ Each new street light distribution center shall be controlled from the building Central Control panel. Where this is impractical, a photo-cell or time clock may be used.
 - ◇ Building entrance lights are considered a part of the campus lighting system and all entrance lights on a building should be served by one branch circuit panel. This panel should contain a contactor and be controlled by the building Central Control panel.

5. DETECTION AND ALARM

- A. The fire alarm control panel shall be located at the fire response personnel entrance. If panels will be subjected to abnormal temperatures, the panel will be designed to compensate for the added heat.
- B. All initiating devices shall be annunciated on the remote interactive graphic display. Initiating devices shall be devices such as manual pull stations, heat detectors, smoke detectors, duct smoke detectors, sprinkler water flow, and standpipe water flow. Sprinkler water flow and standpipe water flow shall also cause the fire alarm supervisory alarm to sound.
- C. Duct smoke detectors located in one room may be grouped for point annunciation on the interactive graphic display. A modular bullet type annunciator shall be located in the room showing each duct detector. The modular bullet annunciator shall be located so that it is visible when a person enters the room.
- D. Room smoke detectors located in one room may be grouped for point annunciation on the interactive graphic display. Smoke detectors shall be grouped for point annunciation by zone.
- E. Fire alarm manual pull stations shall be located at each building exit and elsewhere as indicated by the MSU Department of Police and Public Safety or applicable codes and regulations.
- F. Initiating devices such as kitchen fire protection panel, outside post indicator valve, fire pump, and other miscellaneous initiating devices, when required shall be point annunciated on the interactive graphic display and cause the fire alarm supervisory alarm to sound.
- G. Initiating circuits shall be arranged with maintenance in mind, i.e., one circuit per riser, one circuit per floor, group of duct detectors in a mechanical room on a circuit, etc., so that a trouble on a circuit can be easily traced. Circuits shall be shown on the design drawings.
- H. The maximum load on each initiating and signaling line circuit shall be 50%.
- I. Install strobes on separate circuits from speakers.

- J. Speaker circuits shall be wired for future voice communication.
- K. Speakers shall be installed so as to be heard throughout the building or as indicated by the Department of Public Safety. Visual strobe lights shall be installed in compliance with Americans with Disabilities Act, generally in the following area: auditoriums, classrooms, conference rooms, toilet rooms, and corridors.
- L. Activation of the fire alarm system evacuation alarm shall close all smoke dampers.
- M. The interactive graphic display needs to be configured so that fire response personnel can quickly determine the location of an alarm. Use prominent features such as, stairwells, major corridors, auditoriums, large classrooms, large mechanical rooms, etc. The interactive graphic display shall show each floor of a multi-story building.
- N. Interactive graphic display panels shall be located at the fire personnel response entrance. In large buildings or multiple winged buildings more than one display may be necessary. The exact location of the displays shall be determined by the MSU Department of Police and Public Safety.
- O. A fire alarm riser diagram showing the number of devices and wiring shall be included in the design drawings.
- P. In large buildings or when required by applicable codes, the voice paging (which was designated for future installation) shall be implemented.
- Q. The fire alarm control panel shall have RS232, RS485, and ethernet communication ports in the control panel. Full status monitoring, control, and programming of the fire alarm system shall be available remotely via a terminal connected to the RS232 port. The fire alarm panel shall also have a printer port card to allow the connection of a portable printer to download the fire alarm program and status information.
- R. Install a 1/2 inch conduit from the fire alarm control panel to the nearest Floor Communication Room for Ethernet connection.
- S. A smoke detection system shall be installed as part of the building fire alarm system. The smoke detection system shall meet the following requirements:
 - In buildings where 100% of the area is covered by a sprinkler system, a Partial Coverage smoke detection system shall be installed per NFPA 72 2-1.4.2.2 covering the following spaces: corridors, lobbies, storage rooms, equipment rooms, kitchens, and laboratories.
 - In buildings with less than 100% of the area covered by a sprinkler system or no sprinkler system, a Total Coverage smoke detection system shall be installed per NFPA 72 2-1.4.2.1, except for spaces above suspended ceilings, enclosed stairways, and elevator and dumbwaiter shafts (smoke detection for elevator and dumbwaiter shafts is covered under the Elevator Code).

6. COMMUNICATION SYSTEMS

- A. Telephone System

- AT&T shall install the main telephone service cable into the building and terminate on terminal blocks.
- There shall be one telephone outlet box provided at each desk location and laboratory. There shall be one broadband/computer outlet box at each desk location, and two in each classroom and laboratory.
- The Owner will provide the telephone cable and instrument installation within the building. The Contractor will make reasonable accommodations to allow the Owner's telephone contractor to install the system.

B. Fiber Optic/Broadband System

- The fiber optic system consists of a 72 glass fiber cable constructed in five interconnecting loops. In general, the basic design of the fiber optic system cable installation to a new building will be done by the Owner and given to the Architect/Engineer to be developed into construction drawings.
- The broadband system consists of three 450 MHz cables distributed in a radial configuration. One cable is used for video signal transport, another cable is used for data signal transport, and the third cable is spare. In general, the basic design of the broadband cable installation to a new building will be done by the Owner and given to the Architect/Engineer to be developed into construction drawings.

C. Communication Rooms

- Main Communication Rooms
 - ◇ The campus communication utilities will enter the building at the Main Communication Rooms, (the Broadband Utility Room, the Telephone Utility Room and the User Communication Room). Refer to Design Guidelines – General for space descriptions.
 - ◇ These rooms will have an 8"x 8" cable passage between each room and two 4" conduits from each Main Communication Room to each riser of Floor Communication Rooms and Floor User Communication Rooms.
 - ◇ Each of the main communication rooms shall have two double duplex receptacles. Each double duplex shall be on its own circuit.
- Floor Communication Rooms
 - ◇ The Floor Communication Rooms, (refer to Design Guidelines – General for space description), will house telephone switching equipment, and broadband/fiber optic equipment. The Floor Communication Rooms will have four 4" conduits from floor to floor between each room.
 - ◇ Each Floor Communication Room shall have two double duplex receptacles on their own circuit.
 - ◇ These Floor Communication Rooms shall be stacked one above the other floor-to-floor.

D. Communications Raceway System and Cable

- A cable tray system shall be installed in the corridor consisting of 12" of tray space for telephone, 12" for Broadband, and 12" for user systems. The telephone outlet conduits

and communication outlet (broadband and computer) conduits shall terminate just above the cable tray.

- Communication outlet boxes (used for telephone, broadband, and data) shall consist of an extra deep two gang steel box with a single gang plaster ring and a 1" conduit installed to the cable tray system or the nearest Floor Communication Room.
- Two communication outlet boxes shall be installed at all locations where communications is needed. The boxes shall be spaced approximately six inches apart.
- Any required floor poke-thru or floor box devices shall be Hubbell System One fire-rated devices. Consult with MSU Telecom Systems and IT Services AV group for design application.
- Wall mount telephone outlet boxes shall be an extra deep single gang steel box with a 3/4" conduit installed to the cable tray system or the closest Floor Communication Room. The wall space within 12" from the center of the outlet box in all directions shall be kept clear of all other devices, equipment, attachments, items, etc. to allow space for a wall mount telephone set.
- Communications outlets shall be installed in the Custodial Room, elevator machine rooms, the mechanical room with the main Central Control cabinet, to the fire alarm control panel, and the Transformer vault for Ethernet connection.
- All cable for data, video, or voice communications installed in ducts, plenums, spaces used for environmental air, and vertical runs shall be Teflon jacketed or installed in conduit or metal wireway.
- All cable for data, video, or voice communications installed in concealed building spaces shall have a low smoke producing characteristic jacket or installed in conduit or metal wireway.
- Ethernet cable may be installed in existing telephone conduit provided: the conduit is a minimum of 3/4", and the existing telephone cable is no larger than a single line cable.
- Audio-visual Requirements: Classrooms and auditoriums shall be configured for audio-visual presentations. In general, this includes: preparation for projection equipment and sound reinforcement, and communication raceway and power for computer and video equipment at the front of the room. It also includes communication raceway and power at each desk location for computer connections. The exact arrangement and what configuration to be installed in each room shall be worked out with the Owner.
- A 2" conduit shall be installed from the Broadband Utility Room to the penthouse roof with a weatherhead at the roof penetration for the Campus two-way radio system. The project budget shall include the cost of installing a bidirectional amplification system in the building, mainly to cover the below grade spaces.
- Three 4" conduits shall be installed from the nearest Floor Communication Room to the penthouse roof with a weatherhead at the roof penetration for the installation of enhanced cellular coverage systems within the building.

7. UTILITY METERING NETWORK

- A. Review metering application and equipment with the MSU Power and Water Department at the T.B. Simon Power Plant and the Energy and Environment Office in the Infrastructure Planning and Facilities Building to determine if additional sub-metering equipment is required for utility

billing or for measurement and verification of specific equipment prior to finalizing project specifications and drawings.

- B. At the unit substations, install a 1/2 inch conduit from each metering compartment to one of the metering compartments (designated Main Metering Compartment) to network the wathour meters.
- C. Install a 1-1/2 inch conduit from the Main Metering Compartment to pull box located on the transformer vault wall.
- D. Provide a communications outlet adjacent to the pull box for Ethernet connection.
- E. Install a 3/4 inch conduit from the communication outlet to the pull box and a one inch conduit from the pull box to the Broadband Utility Room.
- F. Install a 1/2 inch conduit from each water, natural gas, steam, and condensate meter to the pull box for networking the building utility meters.
- G. Install a Belden 9463 (single pair shielded) cable from each meter to the Main Metering Compartment.

8. LIGHTNING PROTECTION

- A. "Master Label" lightning protection systems shall be provided for all campus buildings including farm buildings.

9. CLOCK SYSTEMS

- A. Master clock systems will not be used.

10. ACCESS CONTROL

- A. Refer to SAFETY: ACCESS CONTROL in Design Guidelines – General for scope of work.

11. HOUSEKEEPING PAD

- A. All equipment mounted on the floor or resting on the floor shall be on a 4" housekeeping pad. The pad shall extend approximately 3" beyond the bottom edge of the equipment all the way around.

END OF SECTION