

Capital Projects
& Construction

TECHNICAL DESIGN STANDARDS

Revision 2C – October 2nd, 2017



INTRODUCTION

Revision 2C, October 2nd , 2017

Dear User,

Portland State University strives to create a quality environment for all students and users of its facilities. The Capital Projects and Construction Department (CPC), as part of PSU's Office of Planning, Construction & Real Estate, manages all renovation and construction projects on the PSU Campus. We take this responsibility with an enthusiastic approach, reflected in our department's mission: "To design and build a modern, sustainable campus that enhances our student learning experience and reinforces the academic mission".

With the intention of clearly and concisely communicating our standards, including preferences and recommendations, to the team of Consultants and Contractors who work on our projects, we composed these Technical Design Standards. The work involved in the creation of this document comprised obtaining information from important stakeholders on campus, including the professionals who manage PSU's daily campus and maintenance activities, as well as the leaders who define PSU's strategic approach and future vision. Their expertise, experience, ideas, and recommendations, in addition to our own knowledge of best design and construction practices, are incorporated into this document to guide and assist Campus design efforts.

The PSU CPC Technical Design Standards are divided into sections that follow the Construction Specifications Institute (CSI) standards. This format facilitates the use and familiarity by the design and construction professionals. In addition, the guidelines in this document focus on PSU's vision to create facilities having the following characteristics:

- **Adaptability**

PSU buildings, over the course of their lifetime, may be re-purposed for uses that were likely not considered at the time of their design. As such, all buildings must be designed in such a way as to allow for changes in purpose and occupancy.

- **Durability**

PSU buildings need to be resilient. As some of the most heavily and intensely used public buildings in the state, they must be designed to meet dense use, which means all materials and systems must be durable, repairable, and easily maintainable. In addition, State funding for deferred maintenance is scarce, making durability especially important.

- **Maintainability**

PSU has limited resources to allocate to the on-going maintenance of its facilities. Therefore, its buildings and components must be designed to be maintainable using the lowest reasonable amount of resources. For example, inaccessible fixtures and equipment requiring constant servicing should not be included in designs.

- **Timeless Design**

PSU buildings must be designed with the highest sense of aesthetics. The University's status as a premier educational institution in the heart of Portland requires that its facilities reflect this philosophy.

- **Sustainability**

PSU intends that its buildings not only meet the highest level of current sustainable design, but also reflect innovation in this regard. Therefore, targeting highest degrees of efficiency in resources and simplicity of processes are requirements for all campus design and construction activities.

- **Energy Efficiency**

PSU sustainability goals and efforts to become carbon neutral require that all building and major remodels be designed and engineered to be as energy efficient as possible, while providing the necessary level of comfort for the Campus community.

- **Innovation**

PSU, as a leading community institution, must strive for innovation in all construction projects. It must be in the forefront of advocating for the use of innovative design, construction techniques, and building systems.

- **Environmental Health & Safety**

Toxic and hazardous materials should be eliminated from construction materials and components, if possible. Preventing the exposure of building occupants to unhealthy materials is very important to the University.

At CPC we learn from every new project. We believe that the collaboration and input of the in-house team of professionals from various Departments is extremely valuable, and we attempt to constantly encourage their participation. Hence, our Technical Design Standards missive is not a finished and timeless document; it is intended to be reviewed and re-issued every 6 months by our Department as a result of lessons learned from our projects and industry practices, as well as new technologies in construction. In striving for constant improvement, we welcome your feedback.

We are excited about our Department's role in shaping the PSU-of-the-future, while preserving the good things we have today. We are pleased to share this document with our partners and hope it can be used to fulfill our Department's mission.

Sincerely,

The Staff of the Capital Projects & Construction Department

PORTLAND STATE UNIVERSITY
DESIGN AND CONSTRUCTION STANDARDS

TABLE OF CONTENTS

01. GENERAL REQUIREMENTS

- A. SUMMARY REQUIREMENTS
- B. REGULATORY REQUIREMENTS
- C. SUSTAINABLE DESIGN
- D. EXISTING CONDITIONS AND ENVIRONMENTAL ASSESSMENTS
- E. FACILITY SHELL PERFORMANCE REQUIREMENTS
- F. CUSTODIAL REQUIREMENTS

03. CONCRETE

- A. CONCRETE

04. MASONRY

- A. MASONRY

05. METALS

- A. STRUCTURAL METALS
- B. ARCHITECTURAL METALS

06. GENERAL CARPENTRY

- A. ARCHITECTURAL WOOD CASEWORK
- B. FINISH CARPENTRY
- C. METAL STUD WALLS & PARTITIONS

07. THERMAL AND MOISTURE PROTECTION

- A. ROOFING
- B. TRAFFIC COATINGS

08. OPENINGS

- A. DOORS, RELITES, AND FRAMES
- B. DOOR HARDWARE
- C. EXTERIOR WINDOWS

09. FINISHES

- A. FLOORING

PORTLAND STATE UNIVERSITY
DESIGN AND CONSTRUCTION STANDARDS

- B. OTHER SURFACES
- C. PAINT

10. SIGNAGE, SPECIALTIES, AND FURNITURE

- A. EXTERIOR SIGNAGE
- B. INTERIOR SIGNAGE
- C. FLAGS AND BANNERS
- D. RESTROOM ACCESSORIES
- E. MISCELLANEOUS SPECIALTY ITEMS
- F. FURNITURE
- G. TRASH AND RECYCLING CONTAINERS
- H. LACTATION ROOMS

11. EQUIPMENT

- A. APPLIANCES
- B. LOADING DOCKS

12. SITE FURNISHING

- A. BICYCLE PARKING
- B. SKATE & BMX DETERRENTS
- C. FOUNTAINS

14. CONVEYING SYSTEMS

- A. ELEVATORS

21. FIRE SUPPRESSION

- A. FIRE SUPPRESSION SYSTEMS
- B. INSTALLATION

22. PLUMBING

- A. PLUMBING PIPING SYSTEMS
- B. PLUMBING EQUIPMENT
- C. PLUMBING FIXTURES

23. HEATING, VENTILATING, AND AIR CONDITIONING

- A. MECHANICAL SYSTEMS
- B. HVAC SYSTEMS

PORTLAND STATE UNIVERSITY
DESIGN AND CONSTRUCTION STANDARDS

- C. MECHANICAL EQUIPMENT
- D. MECHANICAL INSTRUMENTATION AND CONTROLS

26. ELECTRICAL

- A. COMMON WORK RESULTS FOR ELECTRICAL
- B. LIGHTING

27. COMMUNICATIONS AND AUDIO VISUAL

- A. PHONE AND DATA
- B. AUDIO VISUAL

28. ELECTRONIC SAFETY AND SECURITY

- A. ACCESS CONTROL
- B. SECURITY CAMERAS

28. ELECTRONIC SAFETY AND SECURITY – FIRE ALARM SYSTEM

- A. GENERAL
- B. PRODUCTS
- C. EXECUTION

32. EXTERIOR IMPROVEMENTS

- A. IRRIGATION
- B. PLANTING
- C. LANDSCAPING MAINTENANCE
- D. PAVING

33. PARKING

- A. GENERAL
- B. EQUIPMENT
- C. TECH
- D. BIKE PARKING

APPENDICES

- 01.1. Division 01 (work in development)
- 01.2. Exhibit A: City of Portland CPTED Definition and Policy Strategies
<http://www.portlandonline.com/auditor/index.cfm?c=51503&a=272979>
- 01.3. Environmental Health & Safety
<http://www.pdx.edu/environmental-health-safety/maintenance-construction>

PORTLAND STATE UNIVERSITY
DESIGN AND CONSTRUCTION STANDARDS

- 01.4. PSU Climate Action Plan
<http://www.pdx.edu/planning-sustainability/climate-action>
- 01.5. Custodial and Storage Closet
- 01.6. Restroom Preferences
- 01.7. Office Standards
<http://www.pdx.edu/planning-sustainability/sites/www.pdx.edu.planning-sustainability/files/Office%20Space%20Standards.pdf>
- 01.8. Classroom Standards
<http://www.pdx.edu/planning-sustainability/sites/www.pdx.edu.planning-sustainability/files/Classroom%20Standards%20090314%20final.pdf>
- 01.9. Furniture Standards
http://www.pdx.edu/campus-planning/sites/www.pdx.edu.campus-planning/files/Furniture%20Standards%2008_2016.pdf
- 01.10. Construction Safety Sign Off (Contact CPC for Latest Checklist)
- 01.11. Healthier Buildings Guide
- 01.12. All Gender Restroom Policy
https://www.pdx.edu/campus-planning/sites/www.pdx.edu.campus-planning/files/Media%20Root/All%20Gender%20Restroom%20Policy%2010_6_2017.pdf
- 01.13 Water Efficiency Assessment Policy
- 01.14 Solid Waste Management Policy
- 10.1. Interior Signage
<https://www.pdx.edu/campus-planning/sites/www.pdx.edu.campus-planning/files/Signage%20%26%20Wayfinding%20Standards%208-1-17.pdf>
- 10.2. PSU Identity Standards
<http://www.pdx.edu/university-communications/sites/www.pdx.edu.university-communications/files/PSUStandards9-11Sm.pdf>
- 26.1 Energy Conservation Guidelines for Portland State
<http://www.pdx.edu/sustainability/sites/www.pdx.edu.sustainability/files/Energy%20Conservation%20Guidelines%20for%20Portland%20State.pdf>
- 27.1. Structured Cabling Standards
- 27.2. AV Standards
- 28.1 Access Control
- 32.1 Tree Care Plan
http://www.pdx.edu/sustainability/sites/www.pdx.edu.sustainability/files/Tree%20Care%20Plan%20Final_Pretty.pdf

END OF TABLE OF CONTENTS

PORTLAND STATE UNIVERSITY
DESIGN AND CONSTRUCTION STANDARDS

SECTION 01 - **GENERAL REQUIREMENTS**

A. SUMMARY REQUIREMENTS

1. STANDARDS OF PERFORMANCE

Capital Projects & Construction (CPC) strives to provide and improve access to all for a quality education, including students, faculty, staff and the general campus community. As such, these standards are to be used as follows:

- a. These standards are intended for use as guidelines for construction, materials, and installations on campus. Product installations and other related work shall match existing materials, unless approved otherwise by PSU Project Manager.
- b. While these standards are approved as department standard, exceptions may be made by PSU Project Manager as necessary.
- c. **Integrated Design Process**
Design Lead (e.g, Architect) shall engage interested parties for programming, coordination, and review processes; Implement Integrated Design Process from early pre-design stage through the entire design process; Identify opportunities for innovative design through synergies across disciplines and building systems to improve building performance, occupant well-being, and environmental benefits.
- d. **Codes**
These standards are in coordination with, and are subject to all latest applicable rules, regulations, and codes. Refer to section 1.B. Regulatory Requirements.
- e. **General Conditions for Public Improvement Contracts**
Contractor shall conform to the applicable PUS General Conditions for Public Improvement Contracts.
- f. **Submittals**
Prior to ordering, Contractor shall submit to PSU-CPC and Design Lead for review and approval all products / equipment / furnishings samples colors, paint colors and shop drawings.
- g. **Dimensions**
All drawing dimensions shall have preference over scaled dimensions.
- h. **Structural Engineer Approvals**
Penetrations of Structure by Contractor: Any Penetration of Structure, including anchoring, coring, scraping, cutting or removal is not permitted unless approved by a Structural Engineer that is licensed in the State of Oregon. Upon the Structural Engineer's determination, work shall be subject to special inspection and/or certified location services and reports to determine location of steel reinforcing. Any existing irregularities, flaws, or wear of structure that is uncovered or discovered by Contractor during the process of the work shall be immediately reported to Structural Engineer and subject to the Structural Engineer's review and recommendations.
- i. **Substitutions**
Submit all product substitutions for review within the invitation to bid time line. Refer to Appendix 01.1 – Division 01.
- j. **Close-out**
Provide PSU-Capital Projects & Construction at Closeout with complete approved permit drawings, including fire sprinklers and alarms. Prior to close out of project, provide PSU-CPC with a "redlined set" of as-built drawings and electronic copies, with (3) Operation and Maintenance Manuals. Refer to Appendix 01.1 – Division 01. For projects that

PORTLAND STATE UNIVERSITY
DESIGN AND CONSTRUCTION STANDARDS

includes BIM please provide the additional close-out documents per the BIM execution plan.

- k. Building Information Modeling
BIM will be required for all projects with a value greater than \$5 Million.
- l. Construction Impact Schedule and Coordination
Notify PSU-CPC Project Manager any activities that will create noise, cause utility shut down, or impact parking, waste disposal, access and security a minimum of 2 weeks before the anticipated activity. Refer to Appendix 01.1 – Division 01.
- m. Parking
All parking is to be arranged and paid for by the Contractor.
- n. Keys-Locks
Contractor to order keys for spaces that he or she needs to access via PSU Key Request Form. Contractor to provide payment, deposit and processing of PSU key request forms to receive PSU keys.
- o. Contractor Etiquette
Refer to Appendix 01.1 – Division 01.
- p. Design Strategies
Security: Design of new buildings and major renovations shall consider safety and visibility in order to limit the need for security cameras. Consider principles from Crime Prevention Through Environmental Design - Refer to Appendix 01.2 - Exhibit A: City of Portland CPTED Definition and Policy Strategies
- q. If under any circumstances an accidental discharge to the storm system occurs EHS shall be called. (503-969-8677)
- r. PSU strives to incorporate universal design in the physical layout of PSU buildings and accessibility of the university as a whole. The Disability Resource Center shall be consulted on all matters related to physical accessibility of campus buildings and spaces.

2. EXECUTION

- a. Coordination
Contractor to review all documents and coordinate all work with subcontractors including other PSU contractors and consultants and PSU crews involved in the project.
- b. Existing Conditions
Contractor to field-verify all existing conditions including, but not limited to, dimensions prior to fabrication and installation.
- c. Verify/Protect Existing
Prior to starting field work, contractor to verify and document all existing conditions including compiling digital photographs. Contractor to protect existing building, property, structure and utilities from damage, and replace to existing condition if damaged during construction.
-  d. Recycling Plan
Contractor to complete and submit the Pre-construction recycling plan/applications as required by the City of Portland. For additional requirements refer to Section 01.C.2 of the Technical Design Standards
- e. Safety During Construction
Contractor to provide building safety for tenants and pedestrians to include complete fire, fume, dust, noise control, protection and temporary signage as required during construction. For additional information, please refer to Appendix 01.3 - Environmental Health & Safety.

PORTLAND STATE UNIVERSITY
DESIGN AND CONSTRUCTION STANDARDS

- f. Noise/Quiet Hours
Contractor to conform to all quiet hours required for tenants by project manager and noise requirements for the City of Portland.
- g. Installation
All equipment, appliances, furnishings, cabinets, and product items to be installed according to manufacturer's specifications and recommendations for installation, and to meet all codes for a finished workable product assembly which includes ADA, structural, fire, and safety regulations.
- h. Clean-up
Contractor to provide for complete cleanup of work site at regular intervals. For additional requirements, please refer to Appendix 01.1 – Division 01.
- i. Project Completion Quality
All work shall be completed to provide a new, clean, patched, repaired, painted or finished, working and watertight installation per industry standard for Institutional Facilities. Include finishing /cleaning of carpet, walls, ceilings, equipment, exposed mechanical/electrical items, fixtures and furnishing, and final treatment of floors.
- j. Final Working Installation
Contractor to reconfigure and reconnect existing and new items including utilities, controls, detectors, alarms, exit lighting, strobes, electrical lights, power, switches, mechanical diffusers, ducting, sprinklers, data, plumbing, water, sewer, and venting for a complete working installation.

B. REGULATORY REQUIREMENTS

1. DESCRIPTION

All Design and Construction shall conform to the most recent adopted laws, codes, rules, ordinances, amendments, requirements, as well as Environmental and Waste Management regulations for all pertaining Government jurisdictions, University authorities and documents including but not restricted to the following:

- 2. 2014 Oregon Structural Specialty Code and all updates
- 3. City of Portland Codes and Ordinances
- 4. State of Oregon Codes and Ordinances
- 5. 2010 ADA Standards for Accessible Design
- 6. EPA (Environmental Protection Agency)
- 7. Oregon Department of Environmental Quality
- 8. The Portland State University General Conditions for Public Improvement Contracts
- 9. SHPO State Historical Preservation Office.
- 10. Technical Design Standards, Portland State University
- 11. Portland State University Environmental Health and Safety (EHS) Standards
- 12. PSU Physical Facilities Space Planning and Inventory Manual – PSU Office of Campus Planning and Design.
- 13. Contract Documents.
- 14. City of Portland Parks and Recreation Urban Forestry Divisions

PORTLAND STATE UNIVERSITY
DESIGN AND CONSTRUCTION STANDARDS

C. SUSTAINABLE DESIGN



1. STANDARDS OF PERFORMANCE

Portland State University (PSU) is committed to economic, social, and environmental sustainability. That commitment is acknowledged through our preference for sustainable products including those that are made from rapidly renewable resources, durable, non-toxic, manufactured and sourced locally, harvested sustainably, contain a high percentage of post-consumer recycled content, are comprised of recyclable components, and verified as a sustainable option through industry guidelines or third party organizations such as: Carpet and Rug Institute's Green Label program, Forest Stewardship Council (FSC), Energy Star, or Green Guard.

Portland State University requires all major new construction and renovation projects to achieve LEED Gold minimum certification through U.S. Green Building Council under the most current version of LEED. All other new construction and renovation work shall incorporate LEED and other sustainable design philosophies to the greatest extent possible.

In accordance with PSU's Climate Action Plan (Appendix 01.4), materials with low "embodied emissions", the emissions associated with the extraction, production, transport and use of a given product, are strongly encouraged. Where possible, PSU seeks Environmental Product Declarations for materials which outline life cycle impacts and sustainable attributes.

2. WASTE MANAGEMENT



- a. Recycle construction materials per City of Portland standards and in accordance with a LEED certified waste management plan for major remodel and construction projects. Complete and submit the Pre-construction recycling plan/applications as required by the City of Portland. All landfill and recycling weight tickets and/or hauler invoices should be copied and routed to PSU's Project Manager and Waste Management Coordinator to verify waste management methods and include totals in PSU's diversion rate.
- b. Minimize waste as much as possible by using the four preferred strategies to waste reduction, in this order: source reduction, reuse, recycling, and waste-to-energy.
- c. Provide approved waste and recycling containers for common areas on each floor. Contact and coordinate with PSU's Project Manager and Waste Management Coordinator.
- d. Provide approved compost containers for departmental break rooms and kitchens areas. Contact and coordinate with PSU's Project Manager and Waste Management Coordinator.
- e. Ensure inclusion of approved outdoor infrastructure or containment bay for all waste management activities. Contact and coordinate with PSU's Project Manager and Waste Management Coordinator.
- f. For Projects that generate light ballasts and lamps containing polychlorinated biphenyl and mercury; or other hazardous waste contact EHS..

3. SUSTAINABLE PRODUCTS / MATERIAL HANDLING / SUSTAINABLE DESIGN



- a. See Appendix 01.11 Healthier Buildings for additional best practices.
- b. Daylighting shall be the primary lighting strategy with electric lighting supplementing, as needed. Design for daylighting harvesting in as much of the building footprint as possible.
- c. All new light fixtures/ lamps to be energy efficient and contain low levels of mercury (refer to Electrical Section 26.B). Life-cycle cost analysis and the use of LED fixtures shall be encouraged. PSU expects that use of LED fixtures will increase over time and Section 26 will be updated accordingly.

PORTLAND STATE UNIVERSITY
DESIGN AND CONSTRUCTION STANDARDS

- d. Lighting installations must meet or exceed Oregon Energy Code.
- e. No urea-formaldehyde resins or adhesives permitted.
- f. To every extent possible, materials and adhesives to avoid the “Red List of Chemicals and Materials” as designated by the International Living Building Institute.
<https://ilbi.org/lbc/LBC%20Documents/LBC2-0.pdf>
- g. All fixtures and appliances should be as water efficient as possible, be WaterSense certified, and should assist in achieving Water Efficiency credits in the LEED rating system
- h. Include bottle refill stations in new construction and major renovations and in conjunction with other remodels where feasible. Bottle refill stations may include hydrations stations, retrofitted kits for water fountains, or other solutions that allow users to easily refill water bottles. Install at least one refilling station on each floor of new construction projects and at least one station per building in existing buildings.
- i. All electronics and appliances shall be Energy Star rated and EPEAT certified as applicable.
- j. All materials and finishes should contain the highest percentage of recycled content wherever possible, including concrete, carpet, tiles, flooring, paint, etc.
- k. Carpet tiles are to be used wherever carpet is necessary or requested.
- l. Locally and Regionally sourced finishes and materials within 500 miles are encouraged.
- m. Coordinate all work including discovery, demolition, removal, or storage of hazardous or environmentally sensitive materials with PSU EHS and Project Manager.
- n. Use materials from salvaged sources, where feasible and appropriate.
- o. Use finishes such as flooring or millwork materials from rapidly renewable sources whenever possible.
- p. Use certified wood, wood finishes, or wood products that are considered to have environmental qualities that meet or exceed those of FSC certification whenever possible.
- q. Select paints, coatings, sealant, adhesives, composite wood, carpet and agrifiber products that have low or zero VOC content.
- r. Use a natural linoleum over vinyl composite tile or other sustainable flooring options (recycled rubber flooring, etc.) whenever possible.
- s. In cases of renovation, consider salvage and reuse of existing hardware and structures wherever possible. Work with community partners to salvage architectural materials that are usable but not able to be reused on site.
- t. Consider maintaining-in-place existing products in lieu of replacing with new if in good condition.
- u. Choose high-speed energy efficient hand dryers over paper towel dispensers in all restroom facilities.
- v. Choose paper towel dispenser over hand dryer in a single stall restroom.
- w. Preserve and/or integrate green space and tree canopy wherever possible. Refer to City of Portland Parks and Recreations Urban Forestry Division’s list of recommended species and The Campus Tree Care Plan (Appendix 32.1).
- x. Develop and implement a tree protection plan during construction phase.

PORTLAND STATE UNIVERSITY
DESIGN AND CONSTRUCTION STANDARDS

- y. Implement storm water controls during the construction phase and include storm water management infrastructure in design of campus spaces.
- z. Choose drought tolerant and regionally appropriate landscaping that is suited for existing climate and future climate changes. Choose landscaping that is biologically diverse and provides habitat for natural pollinators.
- aa. Incorporate metering and sub-metering standards set by PSU.
- bb. All retail space utilities shall be metered. Natural gas and electrical utilities shall be metered by the utility company. Water, chilled water and heating water utilities shall have flow meters installed for each retail space and cumulative flow rates shall digitally report to the University's DDC control system. See division 23 Heating, Ventilating, and Air Conditioning and division 26 Electrical.
- cc. Where applicable, the use of permeable pavers is encouraged.
- dd. In new construction, the incorporation of visible, usable, accessible to occupants, and maintainable green roofs must be pursued and implemented when operationally and financially feasible. In major renovations, this design strategy should also be considered. Green roofs shall meet ecosystem services such as habitat promotion, filtration capabilities, limited irrigation requirements. It is preferred that all green roofs are provided with an integral handrail.

D. EXISTING CONDITIONS AND ENVIRONMENTAL ASSESSMENTS

1. TOPOGRAPHICAL SURVEYS

- a. Match all new work to existing survey maps to provide topographic continuity.
- b. Represent all 1-foot ground surfaces on the drawings by means of contours and spot elevations. Show spot elevations at all tie-in locations.
- c. Note all ground floor elevations of existing buildings and slab structures on the drawings to the nearest hundredth of a foot.
- d. Verify and show all storm and sanitary sewer inlet and outlet invert elevations at manholes by field measurement as well as grated elevations. Show underground storm, water and sanitary pipes.
- e. Identify all buildings shown wholly or partially on the finished drawings by name and accented by shading or crosshatching. In tabular form show all major building corner coordinates.
- f. Field-locate, record the location, and identify on map, all surface improvements and natural conditions.
- g. Field-locate all trees and major vegetation and record location on the map. Identify tree size and type on the map. (Protect existing shrubs, trees and lawn areas during the progress of fieldwork; under no circumstances will their removal be permitted.)
- h. Locate all tunnels and manholes, and show floor elevation of tunnels and tunnel coordinates.
- i. Include a general vicinity map, small scale, on the finished drawings. The University will furnish appropriate background.
- j. Provide to the University an electronic copy of each file in Autocad as well as one physical copy of the drawing. Provide typed labels completely identifying the contents of each disc.

PORTLAND STATE UNIVERSITY
DESIGN AND CONSTRUCTION STANDARDS

- k. Prior to construction all sanitary and storm laterals surrounding the project area shall be inspected via camera. Coordinate who will be conducting inspection with PSU Project Manager.

2. DEMOLITION



- a. Where feasible, coordinate and practice “deconstruction” instead of demolition. Deconstruction refers to the dismantling a building where reuse, recycling, and salvage are maximized instead of clearing a site by the most expedient means.
- b. Remove existing walls, doors, frames, finishes, electrical, mechanical, and other building items as required to accommodate new construction.
- c. Remove all abandoned mechanical, electrical, and plumbing lines.
- d. Verify and protect all existing structure. Protect existing lobby areas, restrooms, and elevators. Protect gardens and soils
- e. Generally, the abandonment of existing equipment and material in place is not acceptable. Abandoned systems become a liability since it becomes difficult to determine what is active and what is not. The correction of existing civil problems and removal of abandoned civil equipment, while maintaining the operation of the building, all need to be addressed in the contract documents. Disposal of materials can be a problem with limited on-site areas for temporary storage.
- f. Salvaged materials – Identify items which may be reusable by PSU with PSU’s project manager and arrange to have them moved to a location to be identified by PSU’s project manager.
- g. At the beginning of any remodeling work, cover all return air grilles with filtering material to prevent accumulation of dust in existing duct system.
- h. PSU Post Demolition Certification shall be completed at conclusion of all demolition work (Appendix 01.10).

3. AIR ASSESSMENT



- a. Installation of equipment that produces air emissions, such as paint spray booths and bag filters, may require a "Notice of Intent to Construct" from Oregon Department of Environmental Quality. For further information, contact PSU Environmental Health & Safety (EHS) at 503.725.3738.
- b. Take precautions to prevent visible dust emissions; water trucks and street sweepers, for example, may be required. For further information, contact PSU EHS at 503.725.3738.
- c. Prevent odor emissions that could result in complaints and compromise indoor air quality. When odor is unavoidable, communicate in advance the cause and timeline to those potentially affected.

4. ASBESTOS AND LEAD – ASSESSMENT AND REMEDIATION

All state and federal requirements to be followed as well as any PSU specific requirements. Refer to provisions in the Environmental Health and Safety Specifications and Documents (Appendix 01.3).

5. MOLD ASSESSMENT, REMEDIATION AND RESTORATION



- a. Assessment - Discovery and Analysis:
 - i. Upon discovery or question of possible mold material, notify the Project Manager and EHS immediately. Areas of the suspect material shall be posted, isolated, and avoided. Safety and containment procedures shall be initiated.
 - ii. EHS will initiate preliminary observation and testing as required to determine nature of the material.

PORTLAND STATE UNIVERSITY
DESIGN AND CONSTRUCTION STANDARDS

- iii. In coordination with the Project Manager, EHS will contact an approved and certified testing lab to observe, test, and provide a prompt analysis report of sample materials from site, if applicable.
- iv. Results of Lab report with analysis and recommendations will be reviewed by PSU. EHS will provide recommendations to the Project Manager, including safety precautions for all project personnel, visitors, and surrounding public.
- v. A separate consultant and report may be required to determine the cause of the mold for purposes of incorporating into final restoration.
- b. Remediation and Restoration
Process of Notification, Removal, Treatment, Cleaning and Build-back.
 - i. Upon instructions to provide remediation by EHS, the Project Manager shall notify the Contractor appropriately with regards to possible changes to the Contract due to mold remediation requirements.
 - ii. The Project Manager may elect to retain a remediation contractor outside the project Contract or retain the project Contractor to provide services including remediation specifications, demolition work, remediation work, build-back restoration work, and coordination with existing and on-going project contract work and timeline.
 - iii. Required safety and containment precautions shall be initiated, including personal protective equipment.
 - iv. Contractor shall isolate remediation area from remainder of project and remove mold material.
 - v. Air handling, drying, and monitoring shall be scheduled and contained.
 - vi. Areas of remediation shall be cleaned and treated with EHS approved materials and methods.
 - vii. The Testing Lab shall review the remediation areas in a timely manner and provide analysis to determine schedule of build-back restoration. Recommendations shall be given to PSU and EHS and issued to the Project Manager to safely start the Contractor's build back restoration of the remediated areas.
 - viii. Build- back restoration of remediation area shall include correction of cause of mold.

6. WATER REMEDIATION



Construction projects sometimes generate wastewater, which must be disposed of properly and in consultation with EHS, BES Disposal Permit maybe required. Two common activities that generate wastewater are Masonry Cleaning and Potable Water Flushing. For more information about wastewater disposal, call EHS at 503.725.3738.

- a. Concrete & Masonry Cleaning
 - i. Only wastewater from water-only washing of surfaces that do not contaminate the wash water may be discharged to storm drains. Contact EHS for more information before planning to discharge to a storm drain.
 - ii. Do not allow wastewater or rinse water to soak into the landscaping unless prior arrangements have been made with PSU's Facilities and Property Management (FPM) staff. Some landscaped areas are under a strict watering schedule to minimize plant diseases.
 - iii. When using cleaning products or washing contaminated surfaces, waste water must be collected for discharge to sanitary sewer. At the job site, berms must be set up to prevent wash water from reaching storm drains. Sweep the area to minimize the rinsing of dirt and other solids into the storm sewer.

PORTLAND STATE UNIVERSITY
DESIGN AND CONSTRUCTION STANDARDS

- iv. Wastewater may have to be collected and treated to meet the pH limit of 5.5-12. Agricultural lime has limited effectiveness as a neutralizer. Test the pH of the waste water after treatment and adjust treatment or disposal methods accordingly.
 - v. Lead, asbestos and other hazardous materials cause the wash water to violate sewer discharge limits. If hazardous materials could be in the wash water, samples must be collected and analyzed for the concentrations of those materials. If the water violates local sewer discharge limits, it must be disposed of as hazardous waste.
 - vi. Avoid the use of strong cleaners and solvents, which can cause the waste water to be hazardous waste even after use and dilution with rinse water.
- b. Potable Water Flushing
Potable water may be discharged to the storm drainage system. However, because potable water contains residual chlorine, select a storm drain at least 100 feet away from the point of use to allow chlorine to dissipate into the air before the water enters the storm drain.

7. REMOVAL AND DISPOSAL OF CONTAMINATED SOILS



- a. Many locations on University property have the potential for soil and/or ground water contamination. Sources of contamination include industrial activities such as fuel storage or dispensing or hazardous material spills prior to University acquisition of the property. It is not uncommon to find soil and groundwater contamination where fuel stations, fuel storage tanks, heating oil tanks, emergency generator tanks, industrial activities and landfills are located. EHS will assist with the compliance of Federal and State requirements.
- b. Contact EHS immediately at 503.725.3738 if environmental contamination is discovered or disturbed.
- c. Develop a Work Plan during the design phase to address site contamination issues. Allow enough time for EHS and regulatory agencies to review the work plan.
- d. Disposal of Contaminated Soil and Water
 - i. Pre-plan for site contamination: Contact EHS at 503.725.3738 to discuss environmental assessments and historical information about the site.
 - ii. Hire an environmental consultant familiar with site assessment and cleanup issues. Pre-characterize soils and water for cost estimates; collect enough samples to adequately define the extent of the contamination. Address costs to sample, analyze, manage and dispose of contaminated soil, groundwater and storm water in the contract documents. Additional costs may include worker protection and environmental consulting.
 - iii. All excavated materials must be contained or stockpiled on Visqueen and covered with Visqueen. Representative samples must be taken for waste designation and disposal at PSU authorized disposal sites. Analytical test results must be transmitted to EHS for waste determinations prior to disposal. If any of the wastes designate as hazardous waste, EHS will manage the containment, transport and disposal of that waste through PSU's hazardous waste contract. Petroleum-contaminated soils are not Hazardous Waste but must be disposed at solid waste handling facilities. Solid Waste Handling Facilities classify and manage petroleum-contaminated soils by the concentration of gas, diesel, or heavy oil-hydrocarbons present in the waste. Petroleum contaminated soils above certain hydrocarbon concentrations must be thermally-treated.
 - iv. Contain water that has been in contact with contaminated soils in Baker tanks. Contact EHS for assistance with the proper treatment and disposal of potentially

PORTLAND STATE UNIVERSITY
DESIGN AND CONSTRUCTION STANDARDS



contaminated water. EHS will assist with obtaining sanitary sewer discharge permits if appropriate.

- e. Cleanup Requirements
EHS will assist project managers in determining the extent of cleanup requirements, based on pre- and post-assessment data. Cleanup requirements vary from site to site and depend on the extent and location of the contamination. In some cases, removal and offsite disposal of contaminated soils is necessary, while in other cases, the installation of groundwater treatment systems may be required. In some instances, there is no choice but to leave environmental contamination behind. When environmental contamination remains at a site, the University implements institutional controls to protect human health and the environment
- f. Institutional Controls
Contact EHS for guidance on protecting institutional controls that may already be in place at a known contaminated site. Institutional controls limit or prohibit activities that may result in human exposure to contamination. They may include protective asphalt or a concrete cap over a contaminated site, a restrictive deed or covenant on the property, a vapor barrier, a vapor collection system, groundwater monitoring wells, or a groundwater treatment system.
- g. List of Contaminated Sites
Provide a list that addresses type of contamination and location

E. FACILITY SHELL PERFORMANCE REQUIREMENTS

1. DESCRIPTION

Portland State University has a wide variety of buildings of differing architectural styles, age and material construction. Because of this PSU does not have a single material specified for exterior treatment. When selecting materials for the exterior of all new projects the design team must consider the following when selecting these materials:

- a. Materials must be durable and must be able to withstand weather and pollution with minimal maintenance. Cleaning of the surfaces once every decade with power washing is the norm. Acceptable materials include brick, concrete, and some metals.
- b. Materials must be aesthetically compatible with adjacent buildings.
- c. Metal elements such as trim, exposed structural elements, door and window frames must be designed so as not to need refinishing for at least 50 years. Such metals may include aluminum, copper, and galvanized metals.
-  d. Materials requiring significant and constant upkeep must be avoided and are to be approved by the PSU Project Manager prior to specifying. These include items such as wood, painted metals, EIFS, and plastics.
- e. Locally sourced materials will be given preference over materials manufactured at locations distant from the PSU campus.
-  f. Materials with low embodied emissions are preferred. Where possible, PSU seeks Environmental Product Declarations for materials.
- g. All designs must make use of good architectural practices for shedding water and protecting against weather. Flashings and other design features must be the primary source of weather protection. Sealants, while important elements in good design, must not be used as the primary source of weather and water protection.
- h. All roof with a slope less than 1:10 shall be designed to provide parapet and handrail for safety.

PORTLAND STATE UNIVERSITY
DESIGN AND CONSTRUCTION STANDARDS

- i. For all new buildings and major renovation, layout shall consider secured interior bike storage area. Providing secure storage within one block of project may be considered - verify and coordinate with PSU campus' shared bike shelters plan.
- j. In new buildings that include secured interior storage area, shower facilities shall also be considered.
- k. PSU encourages the use of the following materials when within 10 feet of a sidewalk: glazing, stainless steel, concrete and brick or other forms of masonry.

F. CUSTODIAL REQUIREMENTS

1. STANDARDS OF PERFORMANCE

Portland State University aims to provide its facilities users with a clean, safe and healthy environment. As such, all building design, space design, and construction shall consider the following:

a. Design Strategies

Consider design strategies that minimize building cleaning and maintenance.

- i. When possible and on a case-by-case basis, consider segregating office areas from classroom areas. Ideally, from a cleaning and security standpoint, offices should be designated to upper floors and classroom to lower floors. This allows custodial services to securely clean offices during off hours and restrict general public access.
- ii. Avoid open grid ceilings where mechanical ducts, pipes and structural members can collect dust.
- iii. If designing multi-story curtain walls, design a means for periodic structure and window maintenance and cleaning. Avoid high curtain walls where dust can collect on top of horizontal mullions and access for cleaning is restricted, or else coordinate and assure that the facility has budgeted for specialized cleaning services.
- iv. Doorless entries to restrooms are encouraged. This type of access is less prone to vandalism and other criminal activity. If restroom is located near quiet areas, discuss this strategy with PSU Project Manager and building committee.
- v. In restrooms, design hand wash area to avoid accumulation of water on floor and sink counter.
- vi. See requirements for all gender restrooms in Appendix 01.12.
- vii. Avoid locating bulletin boards behind trash and recycling containers. Residues from trash and recycling materials may stain bulletin boards.
- viii. Provide custodial closets according to design guidelines in Custodial and Storage Closets standards (Appendix 01.5). Provide electrical outlets, constant forced ventilation, and chemical dispensers.
- ix. New buildings and major renovations are required to incorporate a waste collection facility for the building. Design space to fit trash and recycling compactors. Provide a waste collection corral for recyclable and compostable materials. Contact and coordinate with PSU's Waste Management Coordinator and Project Manager.

b. Materials, products and surfaces selection

Minimize cleaning by selecting materials, products and surface finishes that are easy to maintain. In addition, vandalism is a concern at PSU. Select materials, products and surface finishes that are resistant to damage.

PORTLAND STATE UNIVERSITY
DESIGN AND CONSTRUCTION STANDARDS

- i. Minimize finishes (e.g. ceramic tile) that require joints in areas where sanitation is a high concern (e.g. restrooms). Joints (e.g. grout) can stain and grow bacteria. Continuous surfaces are preferred.
- ii. Select surfaces that do not stain, especially in wet areas. Avoid dark colors on surface finishes. Prefer neutral colors, see Section 09 Finishes.
- iii. Prefer flooring products that are seamless and stain resistant. Prefer dark colors.
- iv.  PSU uses “green” surface cleaners with no solvents. When selecting materials, products and surface finishes, consider ones that are easily cleanable with these types of cleaners.
- v. For restroom fixtures, stalls, specialties and special preferences, refer to Appendix 01.6 - Restroom Preferences and coordinate with PSU Project Manager.

G. PERCENT FOR ART PROGRAMS

1. Oregon's Percent for Art legislation guides the acquisition of the state's public art collection. The program began in 1975 and requires that all state agencies, upon legislative approval of construction budgets, must devote no less than 1% of funds for the acquisition of public-facing artwork. The Percent for Art program is administered by the Oregon Arts Commission (OAC). The PSU Project Manager assigned to manage a large PSU capital project coordinates with the Arts Commission's Visual Arts/Public Art Coordinator and the PSU liaison to the Arts Commission on the process of forming a committee, selecting, acquiring and installing artworks.
2. Artwork is selected and commissioned by a committee that typically includes the project architect, project manager, art professionals, community members, and stakeholders from PSU including students, faculty, staff and administrators. Artwork for the public art collection is acquired in different ways. Existing work can be purchased or a request for proposals can be generated through an open call or by invitation. The committee reviews proposals and selects artwork or artists after a thorough discussion and evaluation process.
3. For more information about the Percent for Art program, please click here: <http://www.oregonartscommission.org/programs/public-art/percent-for-art>
4. For more information on the applicable Oregon Administrative Rule, please click here: http://arcweb.sos.state.or.us/pages/rules/oars_100/oar_123/123_475.html
5. For more information on Percent for Art at PSU, please click here: <http://www.pdx.edu/pcre/percent-for-art-projects>

END OF SECTION

PORTLAND STATE UNIVERSITY
DESIGN AND CONSTRUCTION STANDARDS

SECTION 03 - **CONCRETE**

A. CONCRETE

1. GENERAL

-  a. The manufacturing process of concrete creates up to 5% of worldwide CO₂ emissions and needs to be considered when planning for the use of concrete in building design. For this reason and others, the use of recycled concrete aggregate at the highest percent possible is encouraged where appropriate and structurally allowed.
- b. All installation of structural concrete shall be designed and/or reviewed by a structural engineer.

2. DOCUMENTATION

- a. Due to concrete's use as a structural component, all calculations used in the development of structural drawings shall be submitted to PSU and archived with project submittals.
- b. As-built documents, including photographs, will show accurate actual locations of embedded utilities, mechanical, electrical and plumbing chases, and other components concealed from view in finished construction
- c. As-built documents will accurately reflect the location of footings and all subsurface concrete.

3. PRODUCTS

- a. ASTM C150, Type II concrete shall be used in all subsurface and exterior applications.
- b. Unless otherwise specified in structural calculations and structural drawings, the 28 day compressive strength of exterior concrete shall be a minimum 4000 psi for sidewalks and other flatwork. Verify City of Portland requirements for public sidewalks.
-  c. All sealers and coatings for concrete slabs shall be water based low VOC LEED/Green Building Certified and compatible with future treatments.
- d. Edges of low concrete such as planter boxes and benches shall have skate-board deterrents either integral to the form of concrete or metal deterrents installed on the edge surface.

4. EXECUTION

- a. All Steel columns shall be supported on a level grout filled base and not directly supported on concrete slabs or footings
- b. Mechanical areas and areas susceptible to flooding shall have floor drains installed.
- c. Housekeeping pads shall have shrinkage and temperature steel reinforcement conforming to ACI 318 Section 7.12.2.1 at a minimum and be appropriately anchored to the underlying slab with steel doweling.
- d. For non-engineered applications, the use of wire mesh is discouraged in sidewalks and other exterior flat work. Preference is for well compacted ¾"- 0" gravel base and the appropriate use of crack control scoring or saw-cuts and/or appropriately placed rebar.
- e. Exposed concrete in dust-sensitive areas such as labs shall be sealed.

PORTLAND STATE UNIVERSITY
DESIGN AND CONSTRUCTION STANDARDS

- f. For penetrations into existing concrete a GPR (ground penetrating radar) scan shall be performed to determine location of existing rebar and or utilities. All efforts will be made to avoid cutting rebar/utilities with new penetrations.

END OF SECTION

PORTLAND STATE UNIVERSITY
DESIGN AND CONSTRUCTION STANDARDS

SECTION 04 – **MASONRY**

A. MASONRY

1. GENERAL

- a. All installation of masonry units and masonry walls shall be designed and/or reviewed by a structural engineer.

2. DESCRIPTION

- a. The structural engineer is required to design all structural masonry. Fabricator or contractor designed details are not allowed without approval of the structural engineer of record.
- b. The structural engineer is required to design all the structural masonry anchors.
- c. Detail non-bearing walls to allow for vertical deflection of members above. Provide positive connection at top of wall at 4'-0" on center maximum spacing.
- d. Detail non-bearing/shear walls to allow for seismic inter-story drift at both top and each end of walls where adjacent to structural members.
- e. Extend vertical reinforcing up to top of parapet walls. Provide horizontal reinforcing at the top of the wall.
- f. Provide vertical and horizontal reinforcing in CMU walls.
- g. Provide control joints in CMU walls and expansion and contraction joints in brick walls where masonry abuts other surface materials. Joints shall be sealed to prevent penetration of water or moisture in the interior of the wall cavity.
- h. Provide weep holes at all exterior walls or masonry cladding near the wall base every 3'-0".
- i. All masonry shall be above grade.
- j. Masonry units shall be obtained from a single source and/or manufacturer in order to guarantee uniform texture and color or uniform blend.
- k. Use of stack bond is discouraged. If used for architectural reasons, provide a minimum of one vertical reinforcing bar in each stack of block, and horizontal reinforcement throughout.
- l. Provide stainless steel thru-flashing at wall caps, window heads, ledger angles, base bearing, etc.
- m. Provide efflorescence tests with brick submittals for approval. Contractor shall be responsible for removal of all efflorescence that appears on surfaces within 3 years of project completion.

3. PRODUCTS

- a. Masonry
 - i. Submit samples of surface finish textures and color to be approved by PSU Project Manager.
 - ii. In remodel and addition projects, masonry color shall match existing.
- b. Grout and mortar

PORTLAND STATE UNIVERSITY
DESIGN AND CONSTRUCTION STANDARDS

- i. Submit samples and colors for approval by PSU Project Manager.
 - ii. In remodels and additions, color shall match existing.
 - iii. No calcium chloride allowed.
 - c. Reinforcing Steel
Consider specifying reinforcing steel with a high recycled content.
 - d. Sealer
Provide sealer on all exterior masonry.
 - e. Weather Repellent
Provide water repellent coating on all exterior masonry.
 - f. Anti- graffiti coating
Provide anti-graffiti coating on all exterior masonry.
4. INSTALLATION
- a. Prior to installation on major construction projects, provide a 48" x 48" vertical mock-up to verify selection made on submittals, design and execution of wall panel.
 - b. Storage of masonry units shall be such to avoid staining and damage of surface. Provide storage in a dry location. If units are not stored in an enclosed location, cover top and sides of stacks with waterproof sheeting, securely tied. The contractor shall be responsible for any damages that occur to the product.

END OF SECTION

PORTLAND STATE UNIVERSITY
DESIGN AND CONSTRUCTION STANDARDS

SECTION 05 – **METALS**

A. STRUCTURAL METALS

1. GENERAL

- a. A structural engineer is required for the design of all structural steel framing for remodels and new construction and for all metals and fasteners used in the seismic bracing of equipment.
- b. Fabricator/contractor designed details are not allowed unless approved and stamped by an engineer or structural engineer of record on larger projects.
- c. The use of deformed steel reinforcing bars is preferred over the use of welded wire mesh in exterior concrete flatwork if steel is used at all in this application. (See Concrete Standard)
- d. All structural or ornamental exterior steel exposed to weather shall be hot dipped galvanized, aluminum or stainless steel.
-  e. Consider specifying structural steel with a high recycled content.
- f. Structural steel shall be delivered to any construction site with a factory applied coat of primer and be protected from weather until installation.
- g. Metal covered walkways shall not be used.

2. INSTALLATION

- a. All Steel columns shall be supported on a level base of non-shrinking, non-metallic grout and not directly supported on concrete slabs or footings.
- b. Housekeeping pads shall have shrinkage and temperature steel reinforcement conforming to ACI 318 Section 7.12.2.1 at a minimum and be appropriately anchored to the underlying slab with steel doweling.

B. ARCHITECTURAL METALS

1. GENERAL

- a. Contractor shall conform with and provide the following:
 - i. Conformance to all current standards including ASTM, AAMA, AWA, and SSPC.
 - ii. Conformance to paint or coating manufacturer's recommendations and specifications for all finish products including priming, galvanizing, painting, and coatings. All materials to be factory-primed by manufacturer, unless specified otherwise.
 - iii. Submittal of LEED documentation for recycled content, distance, and VOC coating content.
- b. Structural Engineer to review all shop drawings and welding certificates.

1. PRODUCTS

Architectural metals include exposed steel, aluminum, or other metal for shapes or manufactured units or products including screens, mesh, grille-work, ship ladders, railings, platforms, catwalks, and connectors.

END OF SECTION

PORTLAND STATE UNIVERSITY
DESIGN AND CONSTRUCTION STANDARDS

SECTION 06 - **GENERAL CARPENTRY**

A. ARCHITECTURAL WOOD CASEWORK

1. DESCRIPTION

-  Prefer Institutional quality to meet American Woodworkers Institute specifications and standards for AWI custom grade or better, all plywood construction. Encourage use of certified wood, wood finishes, or wood products that are considered to have environmental qualities that meet or exceed those of FSC certification whenever possible.



B. FINISH CARPENTRY

1. DESCRIPTION

Similar to Architectural Wood Casework.

C. METAL STUD WALLS & PARTITIONS

1. DESCRIPTION

- a. Prefer min. 20 gauge x 3- 1/2" wide metal studs at 16" on with 5/8" Type X gypsum board on each side.
- b. It is standard PSU practice to acoustically insulate all new walls and partitions with Roxul or approved equal batt insulation to match wall thickness. Verify acoustical insulation requirements according to room use (e.g. offices, classrooms, bedrooms) and consult with project architect or engineer for additional sound attenuation measures. Follow guidelines in ANSI S12.60-2002, "Acoustical Performance Criteria, Design Requirements and Guidelines for Schools" and LEED.
-  c. Incorporate a niche in walls for campus standard trash and recycling containers. Dimensions shall consider flexibility to accommodate current use and additional future load, as well as usage patterns according to building functions. Provide one niche per 200 lineal feet of corridor. Contact and coordinate with PSU's Waste Management Coordinator and PSU Project Manager.
-  d. The use of modular wall systems such as demountable wall surfaces are allowed and must be discussed with PSU Project Manager before specification.

2. LOCATION

- a. Standard Common Walls.

END OF SECTION

PORTLAND STATE UNIVERSITY
DESIGN AND CONSTRUCTION STANDARDS

SECTION 07 – THERMAL AND MOISTURE PROTECTION

A. ROOFING

1. DESCRIPTION

- a. Adhere to standards and details of latest editions of National Roofing Contractors Association (NRCA) handbook and the Sheet Metal & Air Conditioning Contractors Association (SMACNA) manual.
- b. Provide a minimum ¼” per foot slope to drain.
- c. Provide overflow scuppers and overflow drains per code requirements.
- d. Provide fall protection systems for working on mechanical, electrical and other rooftop items. All fall protection devices to be engineered by Oregon licensed structural engineer and must meet all code and OSHA requirements.
- e. PSU requires that the roof perimeter of all new construction projects have railings or parapets that are at least 42” high at their lowest point.
- f. All Skylights shall meet the OSHA requirements for fall protection.
- g. Prior to any construction the contractor is to provide complete Material Safety and Data Sheets for all roofing components.
- h. Contractor is required to provide submittal information for all roofing products and components.
- i. The Contractor shall provide an Installer’s Warranty of at least 5 years and a Manufacturer’s Warranty of 20 years. On a project by project basis, CPC Director, FPM Director and Assistant Director of Operations and Maintenance, and Associate Vice President for Planning, Construction, and Real Estate will meet to determine any additional extended warranty requirements for roofing duration, building life, and major mechanical equipment (e.g. chillers and cooling towers).
- j. When designing a roof consider that PSU staff, faculty and students may be allowed access to the roof for the performance of maintenance and/or experiments. Work closely with PSU staff to design the roof to accommodate anticipated traffic and use via the installation of approved traffic pads.
-  k. PSU has limited resources to maintain its roofs. Select roofing material that is durable, has built-in redundancy, and requires minimal maintenance. 5-ply built-up roofing and 2 ply - SBS Modified Bituminous Membrane Roofing are good examples of durable roofing systems. Single ply roofing membranes will be considered on a project by project basis.
- l. If applicable, considerations should be made regarding the installation of a white roofing material.
- m. For roofs with flat substructure provide tapered insulation to slope for drains. Minimum ¼” per 1'-0” slope

2. INSTALLATION

- a. All roofing and repair work to be done by Manufacturer approved roofing contractor.
- b. All existing material and labor warranties must be maintained when doing repair or modifications to existing roofing installations.

B. TRAFFIC COATINGS

1. PRODUCT

PORTLAND STATE UNIVERSITY
DESIGN AND CONSTRUCTION STANDARDS

- a. Traffic Coating product shall be discussed with PSU Project Manager prior to construction to ensure system meets current design intent.
2. INSTALLATION
- a. Applicator must be certified to install coating system selected.

END OF SECTION

PORTLAND STATE UNIVERSITY
DESIGN AND CONSTRUCTION STANDARDS

SECTION 08 - OPENINGS

A. DOORS, RELITES & FRAMES

1. DESCRIPTION

- a. Metal doors shall be a minimum 1 3/4" thick, insulated, pre-primed, 16 gauge metal.
- b. Wood doors shall be a minimum 1 3/4" thick solid core with wood veneer to match adjacent.
 - c. Provide blocking at door interior for closers and panic hardware locations.
- d. All door frames and relite frames shall be 16 gauge, pre-primed, welded steel frames. All weld joints shall be ground smooth.
- e. Exterior door frames shall be galvanized or approved exterior finish.
- f. It may be required on some interior door frames, such as wet lab installations or sound proofing applications, shall be reinforced with a basecoat plaster such as Structo-lite for additional strength and durability. Interior door frames such as Knock down door frames are to be avoided and used only upon the approval of the PSU Project Manager.
- g. Fire rated doors and frames shall have appropriate labeling when delivered to the job site and label shall not be painted over, covered at any point.
- h. All rooms with windows, including offices, located along the perimeter of a building shall have doors, relites, and other treatments that allow the penetration of natural light into inner spaces (e.g. corridors and inner rooms).
- i. The design of door lites and relites shall follow specifications in PSU Office Standards (Appendix 01.7) and PSU Classroom Standards (Appendix 01.8).
- j. Door lites and relites shall have a minimum 1/4" thick tempered glass.
- k. Door lites and relites coverings (e.g. blinds) shall be specified according to PSU Office Standards (Appendix 01.7) and PSU Classroom Standards (Appendix 01.8).
- l. Provide flush wood stops at exposed wood unrated doors.

B. DOOR HARDWARE

1. DESCRIPTION

- a. Refer to the PSU Facilities Locksmith specifications as described in Appendix 08.1 – Door Hardware.
- b. In new and major renovations, door frames shall easily accommodate current or future addition of access control and/or ADA opener. Verify electrical path for access control. See section 28 for Access Control Specifications.
- c. In renovation projects, a full inventory of the retrofitted floor must be made to determine if hardware upgrades to improve accessibility are required.
- d. Locking hardware must be mounted at a height that meets ADA requirements. For example, hardware at floor level is prohibited.
- e. Design shall allow for future auto-opener installation clearances & reinforcements. Standard clearance is 10 inches above or below the door.

2. STANDARDS OF PERFORMANCE

- a. All doors to be a complete and functioning, installation approved per code, City of Portland bldg. dept., and the ADA.

PORTLAND STATE UNIVERSITY
DESIGN AND CONSTRUCTION STANDARDS

- b. Standard hardware finish is ANSI 626 or US26D, Lever style to match existing.
- c. Supply and install all door hardware including temporary lock cylinders; temporary cores (also known as “construction cores”) to be Schlage large format interchangeable temporary cores.
- d. Deliver keys to PSU Project Manager.
- e. Coordinate with PSU all required card access control system installations.
- f. Contractor to remove, box, label and deliver all existing hardware on demolished doors, as shown on the demo plan, in coordination with direction received from PSU Project Manager.
- g. If existing office, restroom, or exit doors that remain in area of work don't have approved ADA hardware installed, then replace with new ADA lever/closer hardware described in these notes.
- h. All hardware to be manufactured, specified, and installed per specifications and standards per the Steel Door Institute & Door & Hardware Institute.
- i. Review all hardware operation settings with PSU locksmith prior to final city permit inspector review.
- j. Provide to PSU Project Manager complete hardware submittal list for review and approval prior to ordering and construction.
- k. Provide to PSU at Closeout complete hardware instructions, manufacturer's recommendations and specifications, service manuals and warranty information.
- l. Verify existing conditions.
- m. Verify electrical boxes and conduit runs as required.
- n. Accessible Doors to provide adequate framing for motors and clearance from EXIT signage.
- o. No floor closures allowed.

3. PRODUCTS

a. ACCEPTABLE LOCK TYPE, MANUFACTURER, AND TRIM

i. Cylindrical Lockset	Schlage ND W/Vandelguard	RHO or SPA
ii. Mortise Lock	Schlage L series	06B or 17B
iii. Exit Device #1	Von Duprin 99/98 series	996L 06 or 17 347T EO (no outside trim)
iv. Exit Device#2	Von Duprin 33A /35A	388 or 360L-06/-17 360T EO (no outside trim)
v. Delayed Egress Exit	Von Duprin Chexit	996L 06 or 17 EO (no outside trim)
vi. Dead Bolt	L series	

**PORTLAND STATE UNIVERSITY
DESIGN AND CONSTRUCTION STANDARDS**

vii. Electric Strikes	Von Duprin, HES
viii. Temporary Lock/cylinder TD	Schlage large format interchangeable core housing
ix. Door Closer	LCN 4040 series
x. Door Opener	LCN Senior Swing, LCN 4600 Electric Auto Equalizer, LCN 4800 Pneumatic Equalizer
xi. Hinge, Ballbearing, NRP	Hager, Stanly, Mckinney
xii. Hinge, Plainbearing, NRP	Hager, Stanly, Mckinney
xiii. Manual Flush Bolts	Ives FB457, FB458
xiv. Auto Flush Bolts	Ives FB30/40 series
xv. Drawer Lock	Olympus 888icp-dw Olympus 920 lm/dm
xvi. Cabinet Door	Olympus 777icp-dr Olympus 920 lm/dm
xvii. Access Panels	Olympus 920 lm/dm
xviii. Cylinders	Schlage
xix. Butts	Stanley, McKinney, Lawrence
xx. Electric transfer hinge	Von Duprin
xxi. Key switch	Von Duprin/Schlage
xxii. Exit devices	Von Duprin
xxiii. Locksets and latches	Schlage
xxiv. Stand alone access control	Schlage AD 200 series, Schlage CO 200 series
xxv. Astragal	Pemko
xxvi. Door Stops	Glen Johnson, Ives
xxvii. Push Pull	Builders Brass
xxviii. Kickplates	Builders Brass, Trimco
xxix. Thresholds and weatherstrip	Pemko
xxx. Door operators (ADA)	LCN

PORTLAND STATE UNIVERSITY
DESIGN AND CONSTRUCTION STANDARDS

- xxxi. Automatic door sensors (ADA) B.E.A.
- xxxii. Door actuators (ADA) BEA, LCN, Camdeu, Curran
- xxxiii. Door holders LCN
- b. FINISH
 - i. Match existing building standard or ANSI 626 or US26D
- d. TYPICAL HARDWARE LIST
 - i. Reference Door Schedule and details and Specification Sheets
 - ii. Match existing finishes.
- d. LOCKS AND HANDLES
 - i. Manufacturer: Schlage or approved equal
 - ii. Match existing lever style and color
 - iii. Use Schlage "ND Vandelguard series" -- ND92
 - iv. Storeroom lock-- ND96LD
 - v. Lever Passage lock -- ND10S,
 - vi. Lever Privacy lock -- ND40S.
 - vii. Pocket door latch 990 series.
 - viii. Exit rim and panic bar devices by Von Duprin 98 series at all assembly areas, doors that out-swing from a room, or other areas specified on drawings
- e. CARD ACCESS DOORS
 - i. Provide/Install all transformers or other electrical devices and hardware required to support card access for locks and panic bars.
 - ii. Strikes to be ansitype 10-025, electric as required for card access.
 - iii. Key card access control at exterior entry point. Retro-fit existing or provide at new doors for electric strike. Coordinate with existing PSU system, door hardware, or power opening device.
- f. BUTTS
 - i. Manufacturer: Lawrence, Stanley, McKinney or approved equal
 - ii. (1-1 1/2) pr., to be ball bearing type, use non-removable-pin, on doors with closers.
 - iii. All other doors, use plain bearings, (1-1 1/2) pr., with non-removable-pin.
- g. DOOR STOPS
 - i. Manufacturer: Ives, Glen Johnson or approved equal
 - ii. Wall mount type WS 407 - 2-1 /2" dia.
- h. SMOKE GASKETS
 - i. Manufacturer: Pemko or as approved approved equal.
 - ii. AM 88, black, at all doors in fire corridors on all levels.
- i. BI-FOLD HARDWARE
 - i. Manufacturer: Bi-Fold Hardware, Johnson, or approved equal

PORTLAND STATE UNIVERSITY
DESIGN AND CONSTRUCTION STANDARDS

- ii. Use complete hardware model #200 FD including track , pivots, butts, ball bearing roller guides, and brackets ,
 - iii. Door handles -- 7" wire pulls --.Baldwin or approved equal
- j. **ADA POWER DOOR OPENER**
- 1. Manufacturer: LCN Senior Swing or approved equal, LCN 4600 Electric Auto Equalizer and LCN 4800 Pneumatic Auto Equalizer.
 - 2. Complete electric opener/closer mounted at door head pull side to include (2) wall plate actuators, with key card access at exterior. Retro-fit for ANSI 10- 025 electric strike. Actuators ADA wall mount each side of door. Accommodate lever hardware with and key lock operation. Satin chrome finish.
 - 3. Activate existing power door opener and install exterior wall plate actuator adjacent to door latch access. Retro-fit for ANSI 10-025 electric strike.
- k. **CARD ACCESS DOORS**
- i. Provide/Install all transformers or other electrical devices and hardware required to support card access for locks and panic bars.
 - ii. Strikes to be ansitype 10-025, electric as required for card access.
 - iii. Key card access control at all exterior entry points, including to roof, and at department suite entry and exit points. Retro-fit existing or provide at new doors for electric strike. Coordinate with existing PSU system, door hardware, or power opening device."
4. **EXECUTION**
- a. **INSTALLATION**
- i. Install per manufacturer's specification and recommendation.
 - ii. For installation of locks, use manufacturer's fasteners that come with the hardware.
 - iii. For installation of door closers, use manufacturer's wood/metal fasteners pack; do not use self-tapping sheet metal screws.
 - iv. For electric locks, supply a wiring and a schematic diagram, show locations of power supplies and wire runs.
 - v. Spring hinges and continuous hinges not allowed.
 - vi. Prefer that on metal doors that external exit vertical device rods are not used; Ok to use on wood doors.
 - vii. F. Prefer door assembly installation of welded 16 gauge door frames for break-in deterrent.
- C. EXTERIOR WINDOWS**
- 1. Windows should be designed to be bird friendly whenever possible.
 - 2. When working on historical buildings, windows must be replaced to match existing.
 - 3. Energy efficient windows should be used. Energy efficient windows shall have a minimum conformance with the Oregon Energy Code and one inch thick minimum insulating glass.





END OF SECTION

PORTLAND STATE UNIVERSITY
DESIGN AND CONSTRUCTION STANDARDS



SECTION 09 – **FINISHES**

STANDARDS OF PERFORMANCE





PSU has several key goals when approving and specifying flooring & paint materials. These goals are:

-  a. Finish products must be easy to maintain and clean. No special cleaning or proprietary maintenance products must be required. It is preferred that installed materials do not need to be waxed or sealed or otherwise treated to maintain a clean look.
-  b. Durability is of prime importance. All finish products must be appropriate to the use of the space.
-  c. All materials and finishes should contain the greatest percentage of post-consumer recycled content as possible, including concrete, carpet, tiles, flooring, paint, etc. Use finishes such as flooring or millwork materials from rapidly renewable sources whenever possible. In addition, specified finish products (e.g. flooring) should be recyclable at the end of their life.
- d. Where possible locally manufactured products should be used.
-  e. Paints, coatings, sealant, adhesives, composite wood, carpet and agrifiber products must have low or zero VOC content.
- f. PSU will consider the installation of new products on the market if they meet the above criteria. If new products on the market are proposed, the benefits of using these products must be fully documented and may be installed only if approved by PSU Project Manager.
-  g. To every extent possible, materials and adhesives to avoid the “Red List of Chemicals and Materials” as designated by the International Living Building Institute.
<https://ilbi.org/lbc/LBC%20Documents/LBC2-0.pdf>

A. FLOORING

-  1. DESCRIPTION
 - a. Flooring products must be easy to repair or replace. Modular tile products are preferred where possible.
 - b. Integral walk-off carpet mats are preferred at main building entries from exterior.
- 2. PRODUCTS
 - a. Carpet
 - i. Carpet is to be kept to an absolute minimum.
 -  ii. Carpet and adhesives should be certified by the Carpet and Rug Institute's Green Label program.
 - iii. Carpet should never be used in the following locations:
 - o Laboratories
 - o Restrooms and kitchens
 - iv. In all other spaces, carpet may be used upon approval of PSU Project Manager and Director of CPC prior to installation.
 - v. In all locations where carpet is approved the carpet must be modular tiles.
 -  a. Vinyl and other tile products
 - i. Natural linoleum, cork and other sustainable flexible tile products (e.g. recycled rubber) are preferred in the following locations:

PORTLAND STATE UNIVERSITY
DESIGN AND CONSTRUCTION STANDARDS

- Corridors and hallways
 - Areas where food and drink are served or allowed
 - Elevators, entryways or vestibules
 - Dry lab locations
 - Classrooms
- ii. Avoid vinyl composite products
- b. Epoxy products
- Prefer epoxy flooring, cove bases and wall systems in restrooms. Manufacturers include Silkal, Stonhard or approved equal.
- c. Sheet products
-  i. Natural Linoleum and other sustainable sheet products are preferred in the following locations:
- Areas where food and drink are served or allowed
 - Elevators, entryways or vestibules
 - Wet lab locations
 - Kitchens and kitchenettes
- ii. Do not use linoleum in restrooms, unless approved by PSU project manager
-  iii. Avoid vinyl composite products
- B. Rubber products
-  Rubber flooring is acceptable throughout facilities with exception of restrooms. Prefer rubber product with recycled content. Prefer dark color. Manufacturers include Nora Flooring or as approved by PSU Project Manager.
- C. Tiles and other refractory materials
- i. Tiles and other refractory materials are preferred the following locations
- Kitchens
 - Entryways and vestibules
- ii. Do not use ceramic and clay tiles in restrooms, unless approved by PSU Project Manager.
- D. Stone and terrazzo flooring
- i. Stone and terrazzo flooring may be used only if approved by PSU Project Manager.
- E. Wood
- i. Wood should only be used in areas where wood is required by specific needs such as:
- Sports, dance or other recreational spaces
 - Where matching adjacent spaces such as residential units
- ii. Wood flooring is to be used only when specifically approved by the PSU Project Manager.
-  iii. In all locations where wood is used, FSC certified wood shall be specified, unless approved by PSU Project Manager.
- F. Concrete
- i. Concrete flooring (regular or colored) are acceptable in high traffic areas (e.g. hallways).

PORTLAND STATE UNIVERSITY
DESIGN AND CONSTRUCTION STANDARDS

- ii. Concrete flooring shall be avoided in wet areas since they absorb stains.
- iii. Where concrete flooring is used, provide anti-stain coating and epoxy seams.
-  iv. The use of recycled concrete aggregate is encouraged.
- v. If concrete flooring is used, it needs to be burnished or polished

G. Base

- i. 4" coved rubber base is preferred in all locations except as noted below. Rubber base shall be grey or brown in color unless the PSU Project Manager approves otherwise. Vinyl base is not permitted.
- ii. 4.5" or 6" rubber base is allowed in locations where existing base has been removed and 6" base is required to cover wall damage.
- iii. 6" rubber base is to be used in kitchen, restroom and other wet areas or areas that receive frequent wet mopping.
- iv. Ceramic base is to be used in conjunction with ceramic tile flooring installations.
- v. Wood base is to be used only when matching existing wood base or upon approval of the project manager.
- vi. When sheet products are used it is preferred that the base be formed by turning up the flooring product onto the wall surface.
- vii. When flooring products such as Silkal, Stonhard or epoxy coatings are used, flooring and wall base must be continuous.

H. Exceptions

Exceptions to the above flooring installations must be approved by the PSU Project Manager. Some examples of possible exceptions are:

- i. When matching an existing installation.
- ii. Special uses such as areas requiring non-static flooring, clean labs, machine rooms, etc.
- iii. Unavailability of alternate product options

B. OTHER SURFACES

1. PRODUCTS

- a. Solid Surfaces
The use of solid surfaces, including composite, concrete, and stone for counters is encouraged.
- b. Plastic Laminate
 Plastic laminate is acceptable for countertop applications. FSC and Greengard certification preferred.
- c. Stainless Steel
If using stainless steel surfaces, specify satin or brushed finish. High polished finishes can stain and require increased cleaning.
- d. Wood
Wood finish doors tend to get dirty around handles and locks areas. When wood finish doors are specified, specify protective coating to facilitate cleaning.
- e. Ceramic Tile

PORTLAND STATE UNIVERSITY
DESIGN AND CONSTRUCTION STANDARDS

Any ceramic tile installation shall be discussed with PSU Project Manager for approval.

C. PAINT

1. DESCRIPTION

-  a. All paint must be low or no VOC products. VOC level to be 50 grams/lit or less.
- b. Interior paint to be a satin finish in high traffic common areas such as restrooms and hallways.
- c. Exterior paint to be Acri-lite, Kril Coat or Elastomeric Coating or approved equals.
- d. Satin finish for offices or low traffic areas as requested. Exterior paint to be Satin finish.
- e. Gloss may be used as approved by PSU Project Manager.
- f. First Coat (brand name), Zinnser 123 primer or self-priming paint for new gypsum wallboard (sealer).
- g. Label surplus paint: Contractor must clearly label all surplus paint containers with, at the minimum, the location where the paint was used, brand name, color, type and formula.
- h. Provide washable paint in classrooms near areas that have a possibility of getting dirty with dry markers.
- i. The use of intumescent paint shall be avoided.

2. PRODUCTS / LOCATION

- a. Manufacturer: Miller Paint or approved by PSU Project Manager
- b. The following paint colors are approved PSU colors. Wall and ceiling colors must be limited to these, unless approved by PSU Project Manager.
 - i. Beryl Pearl 0509W
 - ii. Composed CW048W
 - iii. Apple Peel CW030W
 - iv. Crystal Ball 0158
 - v. Wafer E0119
 - vi. Sterling Coin E0159
 - vii. Burbury Beige E0118
 - viii. Popular E0140
 - ix. Fossil 0152
 - x. Hot Chocolate 0145
 - xi. Thai Silk 0107
 - xii. Deep Waters 0025
 - xiii. Spring Tulip Red 0101
 - xiv. Cupola Yellow 0076
 - xv. Savannah 0059
 - xvi. Caliente 0097
 - xvii. Hazel 0024
 - xviii. Alfalfa Sprouts 0054
 - xix. Serenity 0045
 - xx. Haven 0046

PORTLAND STATE UNIVERSITY
DESIGN AND CONSTRUCTION STANDARDS

- xxi. Tranquil 0036
- xxii. Aloe 0058
- xxiii. Showers 0030
- xxiv. Temper 0005
- xxv. Rapids 0017
- xxvi. Pale Organza H0018W
- xxvii. September Leaf 7744M
- xxviii. Lil Melon 06M1909
- xxix. PSU Green 06M2612
- xxx. PSU Accent Green 583U
- xxxi. PSU Brown 469U
- xxxii. PSU Sienna 1675U
- xxxiii. PSU Red 173U
- xxxiv. PSU Orange 7408U
- xxxv. PSU Yellow 460U
- xxxvi. PSU Tan 7502U
- xxxvii. PSU Gray 7497U
- xxxviii. PSU Purple 261U
- xxxix. PSU Blue 7468U
- xl. PSU Light Blue 629U
- c. Clear Finish -- Wood
Miller Nu-Wave or as approved by PSU Project Manager, water based, satin sheen, clear natural coating for wood; (4) coats.
- d. Painted Metal Doors with Window and Door Frames
100% Acrylic for use on metal, PPG Break-Through or as approved by PSU Project Manager, water base, satin sheen. Primer and (2) finish coats.
- e. Door Trim
100% acrylic, satin finish for use on metal-- PPG Break-Through or as approved by PSU Project Manager at Doors and Frames. Must be cleanable. VOC level spec 50 grams/lb.
- f. Interior Wood Stain
Minwax and Old Masters or as approved by PSU Project Manager.
- g. Linseed Oil
Valspar or as approved by PSU Project Manager min (2) coats rubbed after clean existing surface.
- h. Interior Joint Sealers
Silicone GE, Dow, DAP or as approved by PSU Project Manager. Use sanitary type in bathrooms.
- i. Interior Hardwood Doors -- Existing Doors ---Oil rubbed.
Clear Finish : Color -- Natural wood -- Clean existing wood prior to application. Putty sign holes compatible color and material to door finish. New Doors stain to match existing.
- j. Parking Stripes and painted signage -- Parking deck

PORTLAND STATE UNIVERSITY
DESIGN AND CONSTRUCTION STANDARDS

Miller, Seftast Waterborne pavement marking paint, or as approved by PSU Project Manager. Comply with Manufacturer's product data, technical bulletins, and catalog and container application instructions.

- k. Wood floor coatings
Impax epoxy floor coatings, Bona, "Mega Seal WB" polymer , "Varathane" , and "Deft" finish Brush-on: Natural color matching stain on existing hardwood with water-based poly-varnish product.
 - l. Hardwood items
Clear Finish: Color -- Natural wood -- to MATCH EXISTING Use multi-layer UV cured alum oxide finish.
3. INSTALLATION
- a. In all cases paint to be applied with primer and minimum two finish coats of the paint color.
 - b. Paint all areas/surfaces that are part of demolition or new work. At Existing and New Wall Blocking, Patching/Painting -- Paint as required at new and existing gypsum board walls at all new or re-installed installations of electrical, mechanical, plumbing, or other new product or reinstalled items, including grab bars, recessed medicine cabinets, bathroom specialty items, trash chute doors, elect. wall heaters, outlets, lights, switches, and mechanical grilles in wall surfaces.

END OF SECTION

PORTLAND STATE UNIVERSITY
DESIGN AND CONSTRUCTION STANDARDS

SECTION 10 – SIGNAGE, SPECIALTIES, AND FURNITURE

A. EXTERIOR SIGNAGE (PORTION OF STANDARD TO BE UPDATED)

1. DESCRIPTION
 - a. Conform to PSU Campus Planning Office requirements (Appendix 01.7).
2. LOCATION
 - a. All campus property.
3. INSTALLATION
 - a. Conform to latest City of Portland codes and standards and latest ADA standards for installation locations.
4. MATERIAL STANDARDS
 - a. Section not complete, contact PSU Project Manager for detailed requirements

B. INTERIOR SIGNAGE (PORTION OF STANDARD TO BE UPDATED)

1. DESCRIPTION
 - a. Conform to PSU Campus Planning Office and Classroom requirements (Appendix 01.7 and 01.8).
 - b. New construction shall conform to PSU Campus Planning Office requirements (Appendix 01.7). Any deviation must be approved by the Campus Planning Office.
 - c. Existing construction shall conform to existing building sign standard when it exists.
 - d. Existing signage may need to be replaced if not fully compliant with ADA or other code requirements.
 - e. Innovative site specific directional, wayfinding, and placemaking signage is encouraged and must be approved by the Campus Planning Office.
2. LOCATION
 - a. Sign location plan and message schedule shall be submitted to PSU Project Manager.
 - b. ADA compliant tactile sign is required at all entrances to interior spaces where a functional door is present. Spaces shall be marked with proper room number with the exception of RESTROOMS, LACTATION ROOMS, and exit routes, which shall be marked appropriate to their use.
 - c. All rooms with permanent features, such as kitchens, electrical, mechanical, telecom, etc. shall be marked with ADA compliant tactile signs that contain both the room number (first) and the room function(s).
 - d. Within stairwells a code compliant sign indicating the level and additional required information is required at each stair landing. Additionally a separate ADA compliant tactile sign shall be placed at all doors leading off the stairwell. A tactile star shall be included at the exit level.
 - e. Room numbers will be determined by the Campus Planning Office.
 - f. Floor maps and floor directories shall be placed near elevators on all publically accessible levels.
 - g. Building directories shall be placed near all major building entrances or near elevators on all levels where building entrances exist.

PORTLAND STATE UNIVERSITY
DESIGN AND CONSTRUCTION STANDARDS

- h. Maps specifying emergency egress routes shall be located near all egress stairways, in elevator lobby, and as specified by code.
- i. Directional signage shall be placed at any major decision point. Classrooms, office suites with reception area, restrooms, elevators, and stairs are the priorities on this signage.

3. INSTALLATION

- a. Conform to latest City of Portland codes and standards and latest ADA standards for installation locations.
- b. Install per manufacturer guidelines, preserving manufacturer warranty where applicable.

4. MATERIAL STANDARDS

- a. Section not complete, contact PSU Project Manager for detailed requirements
- b. All materials for permanent signage should have a minimum durability of 5 years and an ideal durability of at least 10 years.
- c. Vinyl
 - i. 3M 7125 or 3M 7725 are preferred cut vinyls, others as approved by PSU Project Manager.
 - ii. Avery A9 "Olive Green" may be used to represent PSU Green (Pantone 7496U) when a solid color vinyl is required.
 - iii. Printed materials should be chosen for the appropriate surface and duration of install, as approved by PSU Project Manager.
 - iv. Only manufacturer approved overlaminates may be used.
- d. Adhesives
 - i. 3M VHB tape appropriate to the surfaces being adhered
 - ii. 3M 4941 VHB is appropriate for most wall mounted signs on painted surfaces or glass.
- e. Substrates
 - i. PVC materials may not be used in new construction or in existing construction in a LEED rated building.

5. TEMPORARY CONSTRUCTION SIGNS

- a. Temporary signs, if posted for less than seven days, related to construction may be exempt from PSU Sign Standard, as approved by PSU Project Manager.
- b. Temporary signs that will be in place longer than seven days shall conform to all applicable ADA guidelines and City of Portland codes, including tactile requirements.
- c. Temporary signs that will be in place fewer than seven days should meet ADA visual requirements whenever possible.
- d. Temporary signs shall be promptly removed when no longer required.
- e. Repurposed, recycled, recyclable, and other sustainable materials are highly encouraged for temporary signage.

PORTLAND STATE UNIVERSITY
DESIGN AND CONSTRUCTION STANDARDS

C. TEMPORARY SIGNAGE, FLAGS AND BANNERS (PORTION OF STANDARD TO BE UPDATED)

1. DESCRIPTION

Conform to PSU Campus Planning Office and Classroom requirements (Appendix 01.7 and 01.8), PSU Policy, and City code.

2. LOCATION

All campus property.

3. INSTALLATION

Conform to latest City of Portland codes and standards and latest ADA standards for installation locations.

4. MATERIAL STANDARDS

Section not complete, contact PSU Project Manager for detailed requirements

D. RESTROOM ACCESSORIES

1. DESCRIPTION

Some accessories shall be Owner Furnished, Contractor Installed (OFICI). Their locations, dimensions, and clearance shall be clearly indicated on the plans. These items may include toilet seats, grab bars, shower curtains and hooks, toilet tissue dispensers, shower bath curtain rods, mirrors, medicine cabinets, towel bars and hooks, soap dispensers, paper towel dispensers, shelving, seat cover dispensers, and coat hooks. PSU uses certain vendor provided paper products. These products may require the installation of vendor provided dispensers that are unique to that product. Confirm with the PSU Project Manager prior to specifying restroom specialties to confirm that the specified dispenser is compatible with the vendor provided products. Refer to Appendix 01.6 – Restroom Preferences. Additional signage should be added to all-gender multi-stall. Refer to Appendix 01.12-All Gender Restroom Policy.

2. PRODUCTS

-  a. Choose energy efficient hand dryers over paper towel dispensers in all restroom facilities
- b. Restroom partitions shall be made of scratch and vandal resistant material. Choose materials that can be easily cleaned, easy to remove graffiti from, and can be sanded and refinished (for example, see composite partitions in second floor restroom in Smith Memorial Student Union).

3. LOCATION

- a. Shop drawings must include heights and locations of all specialty items and must be reviewed and approved by PSU Project Manager.

4. INSTALLATION

- a. Conform to ADA standards, Universal Design standards, and City of Portland Codes, Standards and Requirements. If there is a question about the location, please confirm with PSU Project Manager prior to installation.
- b. Contractor to install fire retardant or noncombustible metal blocking and backing as required at specialty items.

PORTLAND STATE UNIVERSITY
DESIGN AND CONSTRUCTION STANDARDS

- c. Partition panels for All-Gender Restrooms shall be 8' tall & shall be installed so that a 9" gap is maintained between the bottom of the partition & the floor. All gender restrooms shall also have zero sight line compartment joints and door stiles.

E. MISCELLANEOUS SPECIALTY ITEMS

1. CLOCKS

- a. Only synchronized clock systems should be installed unless prior approval from PSU Project Manager.
- b. All new surface-mounted clock installations must be equipped to the wireless synchronized clock system. Old surface-mounted clocks will continue to work as they do now and will be replaced as needed by the synchronized clock.
- c. PSU prefers and encourages battery clocks.
- d. PSU Project Manager to coordinate synchronization of clocks with PSU wireless system.
- e. Clocks should be installed in general university conference rooms, public spaces (e.g. student lounges, library, recreation centers, etc.) on a case-by-case basis. Clocks should be installed in all classrooms. Contact PSU Project Manager for additional location needs.

2. WHITEBOARDS OR WRITEABLE WALL SURFACES

- a. Whiteboards shall be used where required (classrooms and conferences, may be considered in other locations. Refer to PSU Classroom Standards – Appendix 01.8
- b. Whiteboards shall be 12' or less.
- c. In public areas, especially student lounges, consider selection of writeable wall surfaces in lieu of whiteboards. Provide signage and/or frames that clearly communicate to users the surfaces where writing is allowed in order to avoid writing on non-writable surfaces. Discuss locations and applications methods with PSU Project Manager.
- d. The use of modular partition systems with writable surfaces such as demounted wall surfaces is allowed and must be discussed with PSU Project Manager before specification.
- e. Chalkboards shall not be installed.
- f. Wall talker white board film is preferred.
- g. Rustoleum prograde dry erase writeable wall surface kits or approved equal will be considered.

3. STUDENT LOCKERS

- f. Student lockers should be considered on a case by case basis. Contact PSU Project Manager for project specific locker requirements.

F. FURNITURE

Refer to Campus Planning Office for classroom, office, furniture standards (Appendix 01.7, 01.8, and 01.9).

PORTLAND STATE UNIVERSITY
DESIGN AND CONSTRUCTION STANDARDS

G. TRASH and RECYCLING CONTAINERS



1. DESCRIPTION

- a. Provide approved waste and recycling containers for common areas on each floor. Contact and coordinate with PSU's Waste Management Coordinator. Refer to Section 06.C.1.c for description of wall niches.
- b. Provide approved compost containers for departmental break rooms and kitchens areas. Provide approved centrally located compost containers in public areas such as study lounges. Contact and coordinate with PSU's Waste Management Coordinator.

H. Lactation Rooms

1. DESCRIPTION

- a. Lactation rooms must be included in major renovations and new buildings. To determine locations contact PSU Project Manager.
- b. Any lactation room must be equipped with a wall plug, keypad lock, latch and dead bolt and appropriate wayfinding signs.

2. PRODUCTS

- a. All furniture and additional amenities need to be approved by PSU Project Manager.
- b. Typical lactation rooms are furnished with a glider and ottoman, side table with bottom rack, bulletin board, and clock.
- c. Additional amenities such as dimmable lights, sinks and mini fridge shall be included, unless PSU project manager indicates otherwise.

END OF SECTION

PORTLAND STATE UNIVERSITY
DESIGN AND CONSTRUCTION STANDARDS

SECTION 11 - **EQUIPMENT**

A. APPLIANCES

1. DESCRIPTION

1. PSU discourages the purchases and installation of dishwashers and garbage disposals. Purchase and installation of these products must be approved by PSU Project Manager.
 -  2. All appliances to be Energy Star rated and/or EPEAT certified as applicable. Refer to Energy Conservation Guidelines (Appendix 26.1).
2. VENDING MACHINES
- a. Contact PSU Project Manager for project specific vending machine requirements.

B. LOADING DOCKS

1. Install Dock Bumpers in accordance with manufactures instructions.
2. Loading Dock Bumpers are preferred for all new construction and remodels.
3. PSU may request that railings be installed on loading dock drop offs. Discuss necessity with PSU Project Manager. Any railings installed shall be OSHA approved. OSHA approved removable railings should also be considered.
4. Lifts shall be installed if ADA ramp is not provided at loading dock.
5. All required permanent safety measured shall be considered for mobile equipment such as fork lift stops.

END OF SECTION

PORTLAND STATE UNIVERSITY
DESIGN AND CONSTRUCTION STANDARDS

SECTION 12 – SITE FURNISHING

A. BICYCLE PARKING

1. DESCRIPTION

- a. General
Provide reinforcing, backing and sleeves in surfaces to receive site items.
- b. Bike Racks
 - i. See Section 33 Parking.

B. SKATE & BMX DETERRENTS

2. DESCRIPTION

- c. General
Provide reinforcing, backing and sleeves in surfaces to receive site items.
- d. Skate Deterrents
Barco Products F1 Series Skate Deterrent or as approved by PSU Project Manager for new construction, FA-FR Series.

C. FOUNTAINS

1. DESCRIPTION

- a. Installation of new fountains on campus is not allowed.
- b. If fountains are approved, product and materials shall be as specified by architect or project manager in consultation with PSU Facilities and Property Management (FPM) staff. Pumping system for fountains must be solar operated. A separate waterproofing plan with details must be provided and approved by PSU Project Manager.

END OF SECTION

PORTLAND STATE UNIVERSITY
DESIGN AND CONSTRUCTION STANDARDS

SECTION 14 – **CONVEYING SYSTEMS**

A. ELEVATORS

1. GENERAL

- a. For new construction, provide traffic analysis showing projected capacity and elevator speed requirements.
- b. Provide traction elevators for all lifts and hoist-ways. The installation of hydraulic elevators is discouraged and is only allowed with PSU project manager approval.
- c. For buildings with two or more elevators, size and outfit one elevator as a freight and passenger dual purpose elevator. (e.g. PSU Engineering Building)
- d. Acoustical treatment for elevator machine rooms shall be provided as necessary to be compatible to the surrounding building usages.
- e. Provide written energy control procedures (provisions for lock-out tag-out) for any new equipment installation. When making modifications to existing equipment, require revisions to the written energy control procedures.

2. PRODUCTS

- a. All elevators to be composed of non-proprietary equipment. Examples of non-proprietary manufacturers include:
 - i. MCE and EC – Elevator Controllers.
 1. Provide Elevator Controls Pixel Controller or approved equal.
 - ii. Hollister-Whitney – Elevator Machinery, Cabs, and Rails.
 - iii. (NOT RECOMMENDED) Proprietary Manufacturers include: Otis, Schindler, Kone, and ThyssenKrupp.
- b. “Bruiser Elevator Accessories” by Innovation Industries Inc. is the preferred manufacturer of hall fixtures and call buttons, Innovation 500 series keys shall be used. Provide discrete wiring rather than serial link.
- c. Wall finishes shall consider maintenance and cleanability. Avoid surfaces that can scratch easily.

3. EXECUTION

- a. Provide stops at all floors with substantial mechanical equipment including rooftops and subbasements.
- b. Provide a dedicated temperature controlled machine room for all elevators to house elevator equipment, controller, and electrical disconnects.
- c. Provide a shunt trip breaker to protect elevator equipment in the event of sprinkler system activation.
- d. Provide phase 1 and phase 2 fire alarm recall functionality and testing for every new elevator.
- f. Refer to Section 28 Electronic Safety and Security for additional integration requirements.

END OF SECTION

PORTLAND STATE UNIVERSITY
DESIGN AND CONSTRUCTION STANDARDS

SECTION 21 – FIRE SUPPRESSION

A. FIRE SUPPRESSION SYSTEMS MATERIAL, EQUIPMENT AND DESIGN

1. STANDARDS OF PERFORMANCE

- a. Compliance with the design standards listed in this section is required unless otherwise noted by the PSU Project Manager.
- b. All work to conform to applicable NFPA and Oregon Fire Code for a complete code compliant installation.
- c. Ease of accessibility to systems/equipment for repair, maintenance, or replacement must be considered in design and construction.
- d. PSU prefers non-proprietary equipment.
- e. At the end of the project, submit to PSU all CAD files and calculations (ex. Battery, current draw, etc.). Provide all equipment start up reports, testing reports, and approvals from AHJ (Authority Having Jurisdiction).
- f. When feasible, fire suppression system systems shall be commissioned by 3rd party after installation on systems valued over \$100,000.
- g. Fire systems shall be tied into PSU BAS on systems when economically feasible.
- h. Fire sprinkler systems must be installed on major remodels, new construction, or per code.
- i. Notify and obtain permit from Fire Marshal for any fire alarm/sprinkler installation, alteration, or removal.
- j. Observe all code and regulations for Fire Watch procedures including notifications to the Fire Marshal.
-  k. All construction shall meet PSU Environmental Health & Safety (EH&S) Hot Work Program.
- l. PSU's insurance carrier is to be consulted on all major and/or high risk fire system modifications.
- m. For modifications to the system or to put systems into "Test", obtain PSU Insurance Carrier Impairment Permit through PSU EH&S.

2. FIRE SUPPRESSION MATERIALS AND METHODS

- a. Black steel pipe is preferred. Piping shall be 2-inch in diameter or smaller, or piping exposed at 8' or less above finished floor shall be schedule 40. Piping 2-1/2 inch in diameter or larger shall be schedule 10. Provide factory applied anti-microbial coating.
- b. Threaded, flanged, welded, and mechanical fittings are approved.
- c. System shall be drainable; drains shall be equipped with a locking mechanism. When feasible, locate drain ports to the exterior of the building. When draining system inside the building, all drains shall be able to accept the demands of fire-systems testing.
- d. Test headers for wet, dry, and combination systems shall be located per code. Provide means to test, drain, and monitor for flow. Provide locking plate, lock and keys.
- e. Piping shall be seismically braced per code and/or by the structural engineer recommendations.
- f. Test headers and stand pipes shall be installed and located per code. Test headers need to be monitored for flow.

PORTLAND STATE UNIVERSITY
DESIGN AND CONSTRUCTION STANDARDS

- g. Provide a shut off valve on every floor with pressure gauges. Provide tamper proof devices.
 - h. Provide back flow prevention that is UL listed and approved by PSU Insurance Provider. Provide butterfly valves on inlet and outlet with Wilkins, or approved equal, backflow with Victaulic on top for monitoring switch and strainer on inlet.
 - i. Contact AHJ for heat tracing and insulation requirements for fire protection piping. Refer to Section 22 and Section 26 for additional requirements.
 - j. When designing additions to existing fire protection systems, verify extent of existing Sprinkler System including above ceilings and in walls.
 - k. When routing wet system piping through electrical and server rooms, containment system must be provided underneath wet pipe (e.g. sheet metal gutter). Provide leak detection.
3. FIRE PUMPS
- a. Manufacturer: Peerless (Fire Pump); Firetrol (Fire Pump Controller's); Grundfos (Jockey Pump); Metron; or as approved by PSU Project Manager.
 - b. Fire pumps must have automatic weekly exercise capability.
 - c. A dedicated fire pump room is preferred.
 - i. The room shall be restricted to authorized personal only
 - ii. The room shall be kept between 40 F – 104 F.
 - iii. All lighting serving the room shall be on emergency power
 - iv. The room shall be rated for 2-hour protection
 - v. Suction piping shall have city water bypass.
 - vi. Identification via signage is require on door exterior.
 - d. Floor drain shall be provided in fire pump room. Drain piping shall not cross the path of travel. Slope floor to drain.
 - e. Fire pumps must have data storage capability at panel and soft start on the motor.
 - f. Provide 100% shut off valves on both ends of test loops.
 - g. Provide pressure gauges on suction and discharge of pump.
 - h. New fire pumps shall be installed on inertia base.
 - i. Provide seismic bracing where applicable.
 - j. Fire pump and jockey pump shall be wired into emergency generator with a dedicated transfer switch when applicable.
 - k. Fire pump shall be tested in accordance with NFPA and (AHJ).
 - l. Fire Pump and panel shall be tied into building's main fire panel. Refer to section 28 for additional information.
 - m. All power and controls associated with fire pump shall be a 2-hour rated assembly approved by AHJ.
 - n. Raceway for conductors shall be as approved by PSU Project Manager.
 - o. Provide written energization, de-energization and testing electrical control procedures (provisions for lock-out tag-out) for any new equipment installation(s). When modifications to existing equipment, require revisions to any written electrical control procedures.

PORTLAND STATE UNIVERSITY
DESIGN AND CONSTRUCTION STANDARDS

- p. Provide written energy control procedures (provisions for lock-out tag-out) for any new equipment installation. When making modifications to existing equipment, require revisions to the written energy control procedures.
4. PRE-ACTION SYSTEMS
- a. Manufacturer: Potter, or as approved by PSU Project Manager.
 - b. Dry systems shall be used when system is exposed to freezing conditions or in sensitive areas (e.g. server rooms, research labs, etc).
 - c. Compressor shall be heavy duty or commercial rated. Compressor will be sized to fill the appropriate system within half an hour. Provide an auxiliary tank. Systems must have auto-bleed.
5. RAIN WATER COLLECTION TANKS FOR FIRE SUPPRESSION SYSTEMS
- a. Tank must be located in basement.
 - b. Provide chemically treatment and/or filtering system for rainwater entering tank.
 - c. The filling of the tank shall be automatic with redundant shut-offs and supplies.
 - d. Provide low/high level alarms and low-low/high-high level alarms.
 - e. Provide secondary containment and leak detection system tied into BAS.
 - f. Provide information to Section 22 designer so that a room drain is provided that can handle the tank capacity.
 - g. When required, provide an OSHA-approved ladder system in order to access tank.
6. FIRE SUPPRESSION STAND PIPES
- a. Fire suppression hose valves shall be located on floor level landings of stairwells. Provide additional drains as required to achieve proper drainage.
 - b. For roof hydrant connections, provide control valve that is freeze proof and connected to building alarm system.
 - c. Fire department connections shall be located to ensure proper clearance from walls, free of obstructions, to allow full swing of fire department wrench handle. Provide method for pipe draining.
7. TEST HEADERS / FIRE DEPARTMENT CONNECTIONS
- a. When planning for system testing, take precautions to avoid creation of exposed low points in the system or areas which may later freeze creating hazards.
 - b. Appropriate clearances must be maintained (e.g. clear path to test header, circulation space, not creating trip hazard, etc) in accordance with relevant regulations.
 - c. Coordinate placement of test headers with the Fire Department. Test headers must have proper clearance around the header, and avoid being placed in front of landscaping.
8. AUTO-FILL VALVES
- a. Auto-fill valves must have mechanical and electrical redundancies to shut off systems when needed.
 - b. Auto-fill valves must have the ability to manually shut off and manually fill.
 - c. Auto-fill valves must have bypass installed on the auto-fill assembly.
 - d. Auto-fill valves must be alarmed/monitored via PSU Building Automation System.
9. FLOW SWITCHES

PORTLAND STATE UNIVERSITY
DESIGN AND CONSTRUCTION STANDARDS

- a. Provide necessary flow switches PSU Project manager and PSU Fire Prevention Manager to approve locations.

10. SPRINKLER HEADS

- a. Minimum 20 pounds water pressure to be maintained at top floor in sprinkler heads.
- b. All new heads shall be UL listed, quick-response type, with chrome finish or easily identifiable and recessed.
- c. Sprinkler heads older than 20 years must be replaced or as required by AHJ.
- d. If necessary install new heads and adjust locations for new construction.
- e. Recessed sprinkler heads shall be used in gymnasiums, residence units, public corridors, and in any place where the ceiling is exposed to impact.
- f. Sprinkler heads shall be caged in mechanical and electrical rooms, janitorial closets, where installed lower than 7 feet above floor and/or similar vulnerable spaces.

11. FIRE HOSE CABINETS

- a. If required by AHJ, existing fire hose cabinets shall be removed.

12. FIRE EXTINGUISHERS

- a. Fire extinguishers to be installed as required by code and as requested by PSU Project Manager & PSU Fire Prevention Manager.

B. INSTALLATION

1. FIRE SUPPRESSION MATERIALS AND METHODS

- a. All piping shall be cleaned, capped, and flushed prior to install completion.
-  b. Disposal of hazardous materials from manufacturing and on-site fabrication shall comply with regulations for disposal of such material.
- c. When extending an existing fire protection system or performing construction near an existing fire protection system, take measures necessary to protect existing system during construction.

13. PRE-ACTION SYSTEMS

- a. Install pre-action control panel located within sight of the pre-action valve. Panel must be accessible and have the code required clearances.

14. RAIN WATER COLLECTION TANKS FOR FIRE SUPPRESSION SYSTEMS

- a. Provide adequate access and clearance for cleaning.
- b. All tank penetrations shall be sealed water tight.
- c. Tank shall be lined. Upon completion of curing time of liner, tank shall be filled and tested for seven consecutive calendar days demonstrating compliance with NFPA 22.

END OF SECTION

PORTLAND STATE UNIVERSITY
DESIGN AND CONSTRUCTION STANDARDS

SECTION 22 – **PLUMBING**

A. PLUMBING PIPING SYSTEMS

1. GENERAL

- a. Ensure as much as possible adequate clearance for ease of accessibility to systems/equipment for repair, maintenance or replacement.
- b. All items in this section shall comply with code and industry standards, unless otherwise noted.
- c. All devices installed in the potable water system of building to be lead free and meet NSF Standard 61 and EPA's "3Ts for Reducing Drinking Water in Schools" Remediation requirements. Replacement fixtures shall meet Section 9 of the NSF Standard and be labeled per NSF requirements.

2. EXPANSION FITTINGS AND LOOPS

- a. For copper, steel, and gas piping, stainless steel braided hose shall be used for flexible pipe connections.
- b. Install expansion joints in accordance with EJMA (Expansion Joint Manufacturer's Association) Standards.
- c. Attach pipe bends and loops to anchors.
- d. Install guides on piping adjoining expansion fittings and loops. Attach guides to pipe and secure to building structure.
- e. Install anchors at locations to prevent stresses from exceeding those permitted by ASME B31.9 and to prevent transfer of loading and stresses to connected equipment.
- f. Clean field welds and abraded areas of shop paint. Paint exposed areas immediately after erecting hangers and supports. Use same materials as used for shop painting.

3. HANGERS AND SUPPORTS FOR PLUMBING PIPING AND EQUIPMENT

- a. Loop hangers are preferred with the exception of no hub pipe. For no hub pipe, clevis hangers are preferred.
- b. Metal insulation shield shall be installed with hangers in order to protect insulation.
- c. For horizontally hung piping, provide a minimum of 2 hangers per pipe section.
- d. Provide steel backing, including pre-manufactured carriers, in walls to support fixtures and piping hung from steel stud walls.
- e. Do not support piping from other piping.
- f. Group parallel runs of horizontal piping shall be supported together on trapeze-type hangers.
- g. When dissimilar metals come in contact with each other, select materials which are compatible to prevent electrolysis, or provide means of isolation between the materials.
- h. Provide prefabricated pipe curb assemblies for roof membrane and insulation penetrations related to equipment.
- i. Piping above roof to be supported with freestanding roof pipe supports.
- j. Install escutcheon plates around horizontal and vertical piping at visible locations through walls, partitions, floors, or ceilings.

PORTLAND STATE UNIVERSITY
DESIGN AND CONSTRUCTION STANDARDS

- k. Wall and floor sleeves below grade or subject to moisture shall have neoprene gasket links bolted together around an interior sleeve forming a watertight seal.
 - l. Wall and floor sleeves shall be UL rated assemblies when needing to maintain fire rating of pipe penetrations through fire-rated assemblies.
 - m. Provide riser clamps at floor penetrations. Install foam pad between clamp and piping. Floor penetrations must be sleeved and sleeve must extend a minimum of 1" above finished floor.
4. METERS, DEVICES AND GAUGES FOR PLUMBING SYSTEMS
- a. Manufacturers:
 - i. Gauges: Precision Plumbing Products or as approved by PSU Project Manager;
 - ii. Digital Domestic Water Meters: Cadillac CMAG or as approved by PSU Project Manager
 - iii. Turbine Domestic Water Meter: Carlon (lead free) or as approved by PSU Project Manager.
 - b. Place gauges at inlet & outlet in each piece of equipment (boiler, expansion tank, storage tank, etc.).
 - c. Positive displacement (liquid) meters and gauges are preferred.
 - d. For pressure reducing valves, provide manual temp. and pressure gauges directly downstream and upstream of valve.
 - e. Digital meter to be installed on incoming water main from City or PSU domestic water loop. Turbine meters are considered for City make up and process water metering (e.g. cooling towers).
 - f. Shut-off valves are required on all gauges.
 - g. Provide instruments with scale ranges selected according to service with largest appropriate scale.
 - h. Provide water hammer arrester when applicable and per the recommendations of Plumbing and Drainage Institute PDI-WH201.
 - i. Hammer arrester shall be installed with ball valve for maintenance purpose.
 - j. Install gauges and meters in locations where they are easily read from normal operating level. Install vertical to 45 degrees off vertical.
 - k. Where adequate space is not available, use meters specifically designed for short pipe lengths.
 - l. Install meters per manufacturer's instruction. Provide recommended upstream and downstream straight pipe length for accurate reading.
 - m. Locate test plugs adjacent to thermometers and thermometer sockets, adjacent to pressure gauges and pressure gauge taps, adjacent to control device sockets, or where indicated.
 - n. Install trap primers per code. Tie into DDC controls if feasible.
5. GENERAL DUTY VALVES
- a. Manufacturer: Powers, Apollo, Zwick or as approved by PSU Project Manager.
 - b. For isolation, ball valves are preferred over butterfly valves.

PORTLAND STATE UNIVERSITY
DESIGN AND CONSTRUCTION STANDARDS

- c. Mechanical domestic water mixing valves are preferred over digital. Provide Symmons Powers or approved equal.
 - d. Use Outside Stem & Yoke (OSY) shut-off valves for pipes 4" and larger.
 - e. For pressure regulating valves, provide inlet, outlet, and bypass isolation valves.
 - f. When possible, provide one set of isolation valves in order to completely isolate all fixtures per space (e.g. classroom, dormitory, bathroom, etc.).
 - g. Install valves where required for proper operation of piping and equipment, including valves in branch lines where necessary to isolate sections of piping.
 - h. Locate valves so as to be accessible; install with chain operators as required. Extend chains to 5-feet above floor and hook to clips to clear aisle passage.
 - i. Provide hand wheels fastened to valve stem for valves other than quarter-turn. Provide lever handle for quarter-turn valves 6-inches and smaller.
 - j. Provide quarter-turn freeze-proof hydrants at various locations on exterior building walls.
 - k. Manufacturer's name and pressure rating to be clearly marked on valve body.
6. **BALANCING VALVES**
- a. Manufacturer: Bell & Gossett, Griswold or as approved by PSU Project Manager.
 - b. Balancing valves shall be installed on all pumping systems downstream of pump. This applies only when a VFD is not installed.
 - c. Balancing valves shall be installed on all branch loops that serve fixtures/equipment (e.g. hot water recirculation loops, hot water heating loops, etc).
 - d. Install balancing valves with flow in the direction of the arrow on the valve body. Allow enough distance away from any fitting as recommended by manufacturer.
7. **CLEANOUTS**
- a. Provide cleanouts under every kitchen sink and at the base of all waste and drain stacks.
 - b. Provide raised head brass cleanout plug for no hub piping.
 - c. Provide ABS cleanout when installing ABS piping; do not provide brass cap.
 - d. Cleanout must be accessible. Install removable floor and wall covers or access panel for concealed piping. Select type to match adjacent building finish.
 - e. Cleanouts in underground sanitary or acid waste systems shall be line size for mains up to 4" Ø. For mains having a diameter greater than 4", cleanouts shall be 4" Ø.
8. **BACK FLOW PREVENTION / CHECK VALVES**
- a. Manufacturer:
 - i. For line sizes less than or equal to 2", use Conbraco or as approved by PSU Project Manager.
 - ii. For line sizes greater than 2", use Wilkins with Victaulic opening to check valve or as approved by PSU Project Manager.
 - b. For main building backflow assembly, install bypass one pipe size smaller than main. Bypass shall be equipped with means for backflow.
 - c. Install Y strainer at main building backflow device and ensure clearances.
 - d. Avoid locating valve(s) in vaults or confined spaces.

PORTLAND STATE UNIVERSITY
DESIGN AND CONSTRUCTION STANDARDS

- e. For 2" and larger, provide OS&Y or butterfly shut off valves with tamper switches on each side of valve.
 - f. Spring check valves, Wafer check valves, and Lift check valves are acceptable for low hazard applications (e.g. pump discharge).
 - g. Vacuum breakers are acceptable for lab sinks, hose bibs and low hazard applications.
 - h. Where practical, locate valve in the same room as equipment being protected.
 - i. Chemical/soap dispensers are to be treated as a high health hazard and are not preferred and must be approved by project manager. If installed for janitorial closets or kitchen they must have a Reduced Pressure Principle Device backflow device.
 - j. Seek review and approval of exact location and type of valve with Authority Having Jurisdiction (AHJ) prior to purchase and installation. Provide all required testing after installation per AHJ requirements and provide appropriate documentation to PSU.
9. ELECTRICAL HEAT TRACING
- a. Install electrical heating tracing system when piping is exposed to freezing conditions.
 - b. Piping shall be labeled accordingly. Label piping indicating circuit and panel locations.
 - c. Plumbing designer to provide projected load information contractor to coordinate with design
10. VIBRATION AND SEISMIC CONTROL FOR PLUMBING
- a. Consider installing vibration control when equipment is above, below, or near noise sensitive area.
 - b. Steel equipment bases shall have the lowest possible mounting height with not less than 1" clearance above floor.
 - c. Set floor-mounted equipment with steel base rails on 4" high concrete housekeeping pads. Extend pad 6" beyond footprint of equipment in each direction.
 - d. Provide mounts for equipment installed outdoors for wind loads of 30 lbs. psf applied to any exposed surface of isolated equipment.
 - e. Do not install equipment or pipe that makes rigid contact with building slab, beams, studs, walls, etc.
 - f. Support water and gas piping, connected to rotating equipment within equipment rooms, on spring and neoprene hangers.
 - g. Fill pump inertia bases with concrete. Support heels of suction and discharge elbows from base.
11. IDENTIFICATION FOR PLUMBING PIPING
- a. Comply with ANSI A13.1 for lettering size, length of color field, colors, and viewing angles of identification devices.
 - b. Provide stickers for identification rather than stenciling. Mechanic fastening is also acceptable.
 - c. Include flow direction for both air and water systems.
 - d. Notify if polypipe or plastic pipe is being used.
 - e. Provide a valve schedule as part of a submittal package. Upon approval from owner, valve shall be framed and installed appropriately in building mechanical spaces by completion of project. Valves shall be tagged in the field per schedule.

PORTLAND STATE UNIVERSITY
DESIGN AND CONSTRUCTION STANDARDS

- f. Provide ceiling tile labels for Plumbing equipment (labeled orange) and plumbing valves (labeled Green). Labels shall be machine generated, with adhesive backed with black letters and clear tape.
 - g. Coordinate with PSU facility maintenance personnel to ensure consistency with the existing piping identification system.
 - h. Tag balancing valves with GPM or CFM. Valve position after balancing is completed.
 - i. Identify plumbing equipment and control panels with plastic nameplates riveted to equipment body.
 - j. Provide stenciled signs on each access door and housing, indicating purpose of access.
12. INSULATION
- a. Manufacturer: Copper/Steel Piping, Fiber Lock; Polypipe, Armaflex
 - b. Do not apply insulation until pressure testing, heat tracing, and general inspections have been completed and approved:
 - c. Insulation shall be continuous through walls, floors and partitions except where otherwise noted.
 - d. For piping and equipment, install insulation over clean, dry surfaces with adjoining sections firmly butted together and covering surfaces. Repair all voids and tears. Lap seal insulation with water proof adhesive. Do not use staples or other methods of attachment which may penetrate vapor barrier. Provide blankets over valves or components that require access.
 - e. For ADA lavatories/sinks provide insulation kit.
 - f. For piping that is exposed to weather, cover insulation with aluminum or stainless steel jacket. Seal water tight jacket and provide heat tracing where piping is exposed to freezing.
 - g. Provide full size diameter hangers and shields (18 gauge minimum).
 - h. For roof and/or overflow Drains above grade, cover horizontal storm drains and overflow drain piping with sectional pipe covering. Cover underside of drain body with insulation, attached with adhesive and supported by structure with strapping anchor.
13. PLUMBING PIPING
- a. Manufacturers:
 - i. Polyethylene pipe: WIRSBO
 - ii. Flexible gas piping: WARDFLEX
 - b. For all applications, copper piping shall be Type L minimum and shall be solder or brazed.
 - c. Condensate piping for drainage of condensate from combustion. Fuel sources shall be polypropylene pipe with fusion weld fittings.
 - d. The use of WIRSBO is allowed for piping 2" or less. Use manufacturer provided fittings. The fitting manufacturer shall match the piping manufacturer.
 - e. Gas piping shall be carbon steel schedule 40. Flexible piping is acceptable for smaller diameter applications of 1" or less.
 - f. Install pipes and pipe fittings in accordance with recognized industry practices.
 - g. Locate piping runs as indicated, vertically and horizontally insulated (pitched to drain). Avoid diagonal runs whenever possible. Allow space for insulation and jackets.

PORTLAND STATE UNIVERSITY
DESIGN AND CONSTRUCTION STANDARDS

- h. Whenever possible in finished and occupied spaces, conceal piping from view.
 - i. Do not run piping through transformer vaults, telephone, elevator, electrical or electronic equipment spaces or enclosures.
 - j. Sleeves are required through all penetrations with fire caulking. Provide nickel or chrome finished escutcheon rings as specified in order to completely cover pipe penetrations.
 - k. Provide vents and drains for piping, coils, and equipment/vessels which contain water. Provide isolation valves. Provide hose connections and caps on drain lines.
 - l. Piping connections to equipment shall be made up with unions.
 - m. Piping shall be cut squarely, free of rough edges, and reamed to full bore. Piping shall be fully inserted into fittings. Press fittings are not accepted.
 - n. Keep pipe openings closed by means of plugs or caps to prevent entrance of foreign matter. Cap all abandoned pipes.
 - o. Welders performing work shall be certified and qualified in accordance with tests prescribed by the National Certified Welding Bureau.
 - p. Provide flanges for steel and copper piping at valves and equipment, unless specified otherwise.
 - q. In order to prevent electrolysis, provide dielectric unions/flanges with high temperature gaskets as required. Avoid contact with dissimilar metals, including contact with Architectural framing. Provide rubber pads in order to isolate piping from floor penetrations, hangers, clamps, and other potential sources of electrolysis.
 - r. For sanitary and storm sewer, use cast iron, ABS, or as approved by PSU Project Manager. Fittings to be no hub, use 4-band fittings.
 - s. For sanitary and storm sewer, piping shall be graded per drawings. Extend piping to discharge. For indirect waste, maintain minimum air gap and provide traps as required.
 - t. Backwater Valves: For residential applications valve shall be ABS. Provide access two times the lid size.
 - u. Pressure-test all piping per code or per engineer's recommendations. Testing shall be witnessed by PSU Project Manager or PSU facility maintenance staff whenever possible. Provide report to PSU and architect.
 - v. Sterilization of domestic water system: Upon completion of tests and necessary replacements, thoroughly flush and disinfect domestic water piping per method outlined by engineer. Provide final certification and reports to owner.
 - w. For major remodels, all waste piping shall be snaked/unclogged by applicable contractor in order to remove sediment that hardens over time due to non-use.
14. FLOOR DRAINS
- a. Manufacturer: Zurn or as approved by PSU Project Manager.
 - b. Install drains to suit floor finish. Arrange for flooring to be sloped to floor drain or sink, including restrooms and labs. P-traps shall match material of piping and be provided with a trap primer assembly. Heat trace and insulate p-traps exposed to freezing conditions.
 - c. Floor drains are recommended in restrooms, janitor's closets, near safety showers, commercial kitchens, laundry facilities, mechanical rooms, and main electrical rooms (if sprinkled). Body of drain shall be cast iron and epoxy coated, plastic may be considered for retrofit applications.
 - d. Unless function of a particular laboratory necessitates inclusion of dedicated floor drain, include a floor drain or floor sink to be located in the adjacent corridor, no further than 25

PORTLAND STATE UNIVERSITY
DESIGN AND CONSTRUCTION STANDARDS

feet from the laboratory entrance. This allows for a single drain to serve multiple laboratories.

- e. Strainer shall be stainless steel, brass or cast iron. Plastic will not be accepted.
- f. Floor drains shall be equipped with trap primer per code if drain is rarely active.
- g. Drains in parking structure shall be manufactured for this application. Strainer shall be selected to avoid debris build-up and tripping hazard.
- h. Area drains in parking structure shall be of steel grate style.
- i. All drainage from parking structure shall be connected to sanitary system or other, per the direction of the City of Portland.
- j. All floor drains shall be vented.
- k. Design and provide roof drains per City of Portland's Plumbing code. All electrical vaults shall have drains or be equipped with a sump. Consult with PSU CPC during design phase to determine direction.
- l. Provide overflow requirements per the City of Portland Plumbing code.
- m. Provide collar and dome for all roof top drains.
- n. Roof drains shall be cast iron body and epoxy coated.
- o. All drainage from roof shall be connected to sanitary system or other, per the direction of the City of Portland

15. LABORATORY PIPING SYSTEMS

- a. Manufacturers:
 - i. Emergency Showers: HAWS or as approved by PSU Project Manager.
 - ii. Mechanical Fitting's/Piping: ORION or as approved by PSU Project Manager.
 - iii. Laboratory Faucets: Chicago or as approved by PSU Project Manager.
- b. Domestic Potable and Non-Potable, Hot and Re-Circulation Water:
Provide polyethylene pipe or copper tubing.
- c. Laboratory Natural Gas
Schedule 40 and 80 black or hot dipped zinc coated galvanized copper. Provide welding and seamless pipe. Piping installed in plenums or shafts shall have welded joints.
- d. Laboratory Gas Piping
Anaerobic Oxygen, Nitrogen, Carbon Dioxide, Compressed Air, and Vacuum shall be type "K" hard drawn seamless copper or stainless steel piping. Do not use soft drawn copper tubing.
- e. DI Water
Piping, fittings, and valves shall be schedule 80 Type 1 homopolymer polyethylene or stainless steel piping. Use socket fusion heat method. Schedule 80 PVC is allowed as an alternate material.
- f. Laboratory Sinks
Provide stainless steel single compartment with ledge, 18 gauge type 316 drop in type. Provide type 316 strainer with tail piece.
- g. Laboratory Faucets
Provide deck mount Chicago Faucets with mixing valve and gooseneck with vacuum breaker. Provide four arm color coded handles, serrated nozzle, and single hole punch.
- h. Emergency Showers/Eyewash

PORTLAND STATE UNIVERSITY
DESIGN AND CONSTRUCTION STANDARDS

Provide emergency shower at door, barrier free emergency shower unit, and eye wash at laboratory sink when applicable. Mixing valve shall mount under sink or recessed in cabinet. Drains are required near locations; consider installation away from equipment. Bradley fucet-mount eyewash model: S19-200B is not allowed to be installed at PSU.

- i. Acid Waste
Use ORION or +GF+ Mechanical Fittings. Acid waste floor drain shall have sediment basket, acid resistant, polypropylene with heavy duty strainer and weep holes. Provide heat fusion joint.

B. PLUMBING EQUIPMENT

1. GENERAL

- a. Ensure adequate clearance for ease of accessibility to systems/equipment for repair, maintenance or replacement
- d. All items in this section shall comply with code and industry standards, unless otherwise noted
- b. Provide valves and flanges at appropriate locations to accommodate maintenance and future replacement.
- c. Provide concrete housekeeping pads when applicable.
- d. Contractor to provide required equipment data for PSU deferred maintenance software.
- e. Ensure that replacement parts and components are available locally.
- f. All equipment shall be started up by factory representative. Documentation shall be provided to owner.
-  g. All equipment shall be as water efficient as possible, be WaterSense and EnergyStar certified where applicable, and shall assist in achieving Water Efficiency credits in the LEED rating system.
- e. All devices installed in the potable water system of building to be lead free and meet NSF Standard 61 and EPA's "3Ts for Reducing Drinking Water in Schools" Remediation requirements. Replacement fixtures shall meet Section 9 of the NSF Standard and be labeled per NSF requirements.

2. IDENTIFICATION OF PLUMBING EQUIPMENT

For identification purposes, stickers shall be used in lieu of stenciling.

3. DOMESTIC EXPANSION TANKS

- a. Domestic expansion tanks shall be tested and stamped in accordance with ASME boiler and pressure vessel code. Pressure shall match the maximum pressure the system is designed for.
- b. Provide support floor mounted tanks with steel legs. Diaphragm shall be removable and inline. Provide pressure gauge and air-charging fitting and drain-fitting.

4. DOMESTIC CIRCULATION PUMPS

- a. Manufacturer shall be GrundFoss or as approved by PSU Project Manager.
- b. Pressure rating shall match maximum working pressure of system.
- c. Body shall be bronze or stainless steel construction. Shaft shall be stainless, ground, and polished.

PORTLAND STATE UNIVERSITY
DESIGN AND CONSTRUCTION STANDARDS

- d. Motor shall be non-overloading at any point on pump curve, be open, drip-proof, and quiet operating. Motor shall have sleeve bearings, rubber mounted construction, and built-in thermal overload protection.
 - e. Pump may be controlled off of aquastat or via the building automation system.
5. SUMP PUMP/SEWAGE EJECTOR PUMP
- a. Provide grinder on the impeller.
 - b. Provide check valve and shut off valve on discharge of the pump.
 - c. Provide perforated 24" x 24" steel basin cover and frame.
6. PACKAGED DOMESTIC BOOSTER PUMP SYSTEM
- a. Manufacturer: GrundFos or as approved by PSU Project Manager.
 - b. Minimum pressure setting shall be 4 feet above top of highest roof level
 - c. Design System to balance pressures on each floors.
 - d. Skid to be furnished with VFD and pump controller located in same panel. Control panel shall accommodate seamless connection to PSU building automation system.
 - e. System shall be factory assembled and tested, and shall be delivered with complete operating controls.
 - f. Common discharge header shall be equipped with purge valve which will divert water to drain in the event of pump failure.
 - g. Pump controller, at a minimum, shall provide low suction cut out, high system pressure cut out, and a no-flow shut down when the hydro pneumatic tank can handle demand.
 - h. System shall be equipped with separate hydro-pneumatic tank to provide low flow demands to the building. Tank shall be equipped with replaceable bladder.
 - i. Pump Seals shall be Unitized EPR/SiC/SiC. Rated for 1000 ppm undissolved solids.

C. PLUMBING FIXTURES

1. GENERAL

- a. Ensure adequate clearance for ease of accessibility to systems/equipment for repair, maintenance or replacement.
- b. Fixture Connections: Provide ¼ turn angle stop's, escutcheon rings and stainless steel braided hose for hot water and cold water connections to fixtures; Chrome p-trap for lavatories, ABS acceptable when p-trap is not exposed.
- c. Hot water knob shall be on the left hand side and cold water knob shall be on the right hand side unless otherwise noted.
- d. Accessible fixtures shall be provided per code; meet all barrier free requirements.
-  e. All new fixtures shall be as water efficient as possible, be WaterSense certified where applicable, and should assist in achieving Water Efficiency credits in the LEED rating system.
- f. All devices installed in the potable water system of building to be lead free and meet NSF Standard 61 and EPA's "3Ts for Reducing Drinking Water in Schools" Remediation requirements. Replacement fixtures shall meet Section 9 of the NSF Standard and be labeled per NSF requirements.

PORTLAND STATE UNIVERSITY
DESIGN AND CONSTRUCTION STANDARDS



- g. For all plumbing fixture replacements or additions reference the Uniform Plumbing Code 2006 Table A-2 (table is also provide on the last page of this division) and "Water Efficiency Assessment Policy." All fixture selections shall be based on adherence to this policy and the chart.



2. HYDRATION LOCATIONS / BOTTLE REFILL STATIONS

- a. Bottle refill stations may include hydrations stations, retrofitted kits for water fountains, or other solutions that allow users to easily refill water bottles. Install at least one refilling station on each floor of new construction projects and at least one station per building in existing buildings.
- a. Manufacturer: HAWS, Elkay, or as approved by PSU Project Manager.
- b. Pentek filters with quick disconnect, or as approved by PSU Project Manager, are preferred for hydration stations and combo drinking fountain / hydration stations. Provide adequate access for cleaning.
- c. Provide combination drinking fountain and hydration station for all new buildings and major remodels. These shall be recessed in walls and splash-proof.

3. DRINKING FOUNTAINS



- a. If drinking fountains are approved and installed, fountains shall include Chicago bottle filler infrastructure for filling water bottles.
- b. Manufacturer: HAWS or as approved by PSU Project Manager.
- c. Do not specify refrigerated drinking fountains.
- d. New installations shall be recessed in wall and be bi-level.

4. MOP SINKS

- a. Mop sinks shall be flush to the ground and installed with stainless steel backing. Rounded base is preferred.

5. COMMERCIAL/PUBLIC KITCHEN SINKS

- a. Manufacturer: Stainless steel Kohler or InSinkErator or as approved by PSU Project Manager.
- b. Faucet shall have means to prevent HW and CW cross-over (e.g. check valve).
- c. Provide Chicago Dual Handle with wrist blade handle and quarter turn ceramic cartridges.

6. COMMERCIAL/PUBLIC LAVATORIES

- a. Manufacturer: Kohler, Lavatories; Chicago, Faucets; or as approved by PSU Project Manager.
- b. Wall hung and countertop installs are acceptable.
- c. Single handle faucets not allowed; provide two handle wrist blades with quarter turn ceramic cartridge.
- d. Vandal proof faucets not allowed.
- e. Electronic faucets are not allowed.

7. COMMERCIAL/PUBLIC WATER CLOSETS AND URINALS

- a. Manufacturers:
 - i. Water Closets: Kohler or as approved by PSU Project Manager.

PORTLAND STATE UNIVERSITY
DESIGN AND CONSTRUCTION STANDARDS

- ii. Urinals: Sloan WES Water Free Series or as approved by PSU Project Manager
 - iii. Manual Flushometers: Sloan Upper Cut or as approved by PSU Project Manager.
- b. For new construction waterless urinals are preferred and should be selected to allow future conversion to wet urinals in case necessary.
- c. Provide additional backing for wall hung water closets and urinals in order to support additional load.
- d. Dual flush flushometer is preferred. Motion detection is acceptable for urinals. Confirm plumbing flushometer design with PSU Project Manager prior to specifying.
- e. Water closet seat shall be commercial grade, open front, anti-microbial, solid white or black.
- f. Water closets shall be as water efficient as possible and use 1.28 gallons per flush or less
- g. For each major bathroom group (3 stalls or more), provide one bariatric water closet and carrier.
8. COMMERCIAL SINK GARBAGE DISPOSERS
- a. Garbage disposers are discouraged. Garbage disposers should only be used if approved by PSU Project Manager.
 - b. Manufacturer: InSinkErator or as approved by PSU Project Manager.
 - c. Provide switches, controls, solenoid and flow control valves, vacuum breakers and appropriate sink or cone attachments.
9. NON-RESIDENTIAL INDIVIDUAL SHOWER UNITS (work in development)
10. RECREATION SHOWER UNITS (work in development)
11. RESIDENTIAL LAUNDRY SINKS
- a. Manufacturer: Mustee or as approved by PSU Project Manager.
 - b. Two bowls are preferred.
12. RESIDENTIAL LAVATORIES
- a. Manufacturer: Kohler, American Standard Lavatories; Faucets - Symmons S-20-2, Chicago; or as approved by PSU Project Manager.
 - b. Faucet shall have means to prevent HW and CW cross over, i.e. check valve.
 - c. Provide InSinkErator, stainless steel
13. RESIDENTIAL TUB-SHOWER UNITS
- a. Manufacturers:
 - i. Tub and shower: Fiber-Fab or as approved by PSU Project Manager.
 - ii. Drain and overflow: Watco or as approved by PSU Project Manager.
 - iii. Shower drains: JackRabbit or as approved by PSU Project Manager.
 - iv. Mixing valve: Delta Universal R10000 or as approved by PSU Project Manager.
 - v. Trim: Delta T3020 or as approved by PSU Project Manager.
 - vi. Tub spout: Delta RP5834 or as approved by PSU Project Manager.
 - b. Mixing valve shall have integral service stops.

PORTLAND STATE UNIVERSITY
DESIGN AND CONSTRUCTION STANDARDS

14. RESIDENTIAL ACCESSIBLE TUB-SHOWER UNITS

- a. Manufacturers:
 - i. Shower system: Symmons Temptrol II or as approved by PSU Project Manager.
 - ii. Roll-in and Transfer shower: Fiber Fab or as approved by PSU Project Manager.
- b. Shower system shall include mixing valve, shower head with arm and flange, lever diverter, wall/hand shower with flexible metal hose, and slide bar.
- c. Mixing valve shall have integral service stops

11. RESIDENTIAL ACCESSIBLE WATER CLOSET UNITS

- a. Manufacturers:
 - i. Water Closet (Tank Type): Niagara Stealth, American Standard Pressure Assist or as approved by PSU Project Manager.
 - ii. Water Closet (Non-tank) and Urinals: Kohler or as approved by PSU Project Manager.
 - iii. Flushometer Valve for Non-tank toilets: Gerber Top Spud or as approved by PSU Project Manager.
 - iv. Flushometer Valve for Urinals: Sloan or as approved by PSU Project Manager.
 - v. Toilet Seat: Church 100ec and 585ec or as approved by PSU Project Manager.
- b. Provide Solid vs liquid type flushometer

15. RESIDENTIAL SINK GARBAGE DISPOSERS

Residential sink garbage disposers are discouraged. Residential disposers should only be used if approved by PSU Project Manager.

16. RESIDENTIAL WASHER BOXES

- a. Manufacturer: Wirsbo, Sioux Chief or as approved by PSU Project Manager.
- b. 1/4 turn valves, angle stops, and lead free.

17. RESIDENTIAL ICE MAKERS

- a. From wall to fridge, use stainless steel braided or copper hose.
- b. Aqua pure filters are preferred.

END OF SECTION

PORTLAND STATE UNIVERSITY
DESIGN AND CONSTRUCTION STANDARDS

SECTION 23 – **HEATING, VENTILATING, AND AIR CONDITIONING**

A. MECHANICAL SYSTEMS

1. GENERAL

- a. Ensure code required and adequate clearance for ease of accessibility to systems/equipment for repair, maintenance, or replacement
- b. Select equipment and supplies that are locally available when possible.
- c. Vibration and noise must be considered in design. Install systems where it causes the least disturbance. Otherwise use noise and/or vibration dampening. If duct boots between spaces are necessary, include adequate offset and insulation.
- d. Install ample valves and unions to isolate equipment, main lines, and branch lines for unobtrusive maintenance operations. Bypasses shall also be provided at incoming water service entry and at items requiring maintenance.
- e. Testing and Balancing of air and water systems shall be performed prior to the conclusion of each project. All filters shall be replaced, strainers cleared, and equipment started up prior to balancing.
-  f. All systems shall be designed to optimize energy efficiency, improve indoor environmental quality, and assist in achieving credits in the LEED rating system. Refer to Energy Conservation Guidelines (Appendix 26.1).
- g. PSU's standard temperature range is 68-76 Degrees Fahrenheit.

2. NON-MOTORIZED VALVES

- a. Manufacturer: Zwick or as approved by PSU Project Manager.
- b. If Mueller butterfly valves are installed, a three-year parts and labor warranty needs to be provided.
- c. Valve tags are required for all valves. Valve tags shall be "System ID - Valve ID". System ID identifies what type of system it is e.g. Well Water Supply / Return, Condenser Water Supply / Return, Domestic Cold Water, etc. etc., Valve ID is the type of valve e.g. ball valve (BV), Check Valve (C1). For example "CDS-BV" this would mean a ball valve on a condenser water supply piping.
- d. Valve operations must be verified by contractor with PSU Project Manager prior to project closeout.

3. METERS AND GAUGES

- a. Manufacturers:
 - i. Steam Meter: Cadillac Vortex Shedding Meter or as approved by PSU Project Manager.
 - ii. Chilled Water Flow Meter: Onicon (non-turbine type) or as approved by PSU Project Manager.
 - iii. Gas Meter: Sensus or as approved by PSU Project Manager.
 - iv. Digital Electrical Sub-Meter: Siemens DEM or as approved by PSU Project Manager.
 - v. Condensate Meter: Carlon Company, or approved equal.
- b. All piping components shall be rated for the service, pressure, and temperature as called out by design engineer.

PORTLAND STATE UNIVERSITY
DESIGN AND CONSTRUCTION STANDARDS

- c. Provide manual temperature and pressure gauges directly in the piping on the inlet and outlet of hydronic equipment. Provide additional gauges as required.
 - d. All gauges to have shut-off valve in order to remove/replace/test.
4. HANGER SUPPORTS AND HANGERS
- a. All hangers, rods, clamps, protective shields, components, and hanger accessories shall be hot dipped galvanized.
 - b. Seismic restraints, anchorage and reinforcements shall be provided for all piping and designed to withstand forces generated by earthquake movements.
 - c. Support all vertical risers/piping per floor. Support all horizontal piping per code and schedule. Floor penetrations must be sleeved and sleeve must extend a minimum of 1" above finished floor.
 - d. Provide roller guides, anchors, and expansion joints as specified by structural/mechanical engineer.
5. INSULATION
- a. For steam, condensate return, and boiler, feed water piping insulation shall be molded glass fiber with aluminum jacket. Provide reusable insulation blanket around valves, pumps, and piping specialties.
 - b. For chilled water piping, provide polyisocyanurate foam insulation with PVC jacket. Provide blue jacket color for chilled water systems. For smaller diameter piping within buildings, fiberglass insulation is acceptable. Underground direct bury piping shall be doubled walled with the outer carrier pipe to be constructed of factory prefabricated HDPE jacketed system of factory pre-insulated pipe with all necessary fittings. For steam, condensate return insulation shall be high temperature foam insulation capable of withstanding continuous temperatures of 400 Degrees Fahrenheit. For chilled water, provide polyurethane foam insulation.
 - c. Provide reusable insulation blanket around valves, pumps, and piping specialties.
 - d. Pre-manufactured insulation elbow shall be used for piping insulation. Foam fill of elbow is unacceptable.
 - e. Underground direct bury piping shall be doubled walled with the outer carrier pipe to be constructed of factory prefabricated HDPE jacketed system of factory pre-insulated pipe with all necessary fittings. For steam, condensate return insulation shall be high temperature foam insulation capable of withstanding continuous temperatures of 400 Degrees Fahrenheit. For chilled water, provide polyurethane foam insulation.
 - f. Outdoor piping shall be insulated with aluminum jacket.
 - g. Insulation shall be sized correctly with no air gaps and per manufactures recommendations.
6. ELECTRIC HEAT TRACING
- a. Electric heat tracing shall be installed on exterior piping that is subject to freezing.
 - b. Label pipe indicating heat tracing as well as which circuit and panel it is fed from.
 - c. For large systems provide a front end controller, with alarm-able output
 - d. Use 120VAC system.
 - e. Heat tracing systems should be clearly labeled on the systems they are serving.
7. LIQUID FUELING SYSTEMS

PORTLAND STATE UNIVERSITY
DESIGN AND CONSTRUCTION STANDARDS

- a. If using an automated fueling system, the system must have a fuel return system that is capable of handling all of the feed fuel. Additionally, it must have secondary containment, automatic shut-off and alarm devices, manual re-set, and a gravity fuel return system.
 - b. Intertie automated fueling system with building automation system.
 - c. The liquid fueling system must be tested prior to start up with applicable medium (e.g. diesel).
 - d. Place sight glass on outside of all fuel storage tanks in order to confirm fuel levels.
 - e. Leak detection system on any storage tanks is required.
 - f. Capability to lock out manual fueling systems is required.
 - g. Underground fuel storage tanks and associated piping must comply with federal and state regulatory requirements and must be specifically approved by PSU's EHS department.
8. FACILITY NATURAL GAS SYSTEMS
- a. Natural gas pressure reducing valve (PRV) shall have test ports on each side of valve. Provide a dedicated PRV for each piece of equipment. Design flows shall be in the middle of the PRV spring range.
 - b. If piping is exterior to building, it shall be finished with a weather resistant finish.
 - c. Natural gas piping greater than 1" in diameter is required to be rigid piping and painted bright yellow.
 - d. A seismic shut-off valve is required at the building's main gas feed. The seismic shut-off valve must have a 3-valve bypass. Vertical and horizontal valve considerations need to be considered. All installs need to be coordinated with utility provider. Do not install on utility side of the meter.
 - e. Non- Utility main line gas meters must have a bypass.
 - f. Piping must be tested and approved by City of Portland prior to start up.
 - g. Yellow armafex can be used for the last two feet length of gas connections less than 1".
 - h. Steel pipe needs to be seamless.
 - i. For lab applications, provide emergency shut off at lab entry.
9. HYDRONIC PIPING
- a. Hydronic piping shall be copper or black iron. Plastic piping is not allowed.
 - b. Hydronic piping must have isolation valves and unions at all pieces of equipment. Unions shall be placed at applicable locations for equipment replacement. Verify operations with Owner Representative prior to project closeout.
 - c. For radiant heating panels, use manufacturer's factory rated hose with swivel end (factory assembled). Field quick connects are not allowed.
 - d. Provide dielectric connections as required.
 - e. Prep, clean, and store piping per the design engineer's direction and to ensure no unneeded chemical/bacterial contamination.
 - f. Welled systems are preferred. Grooved systems, except for steam piping, are allowed with approval.
 - g. Where pipes penetrate floors, sleeves around pipes shall extend a minimum of 4" above floor level to act as containment around the penetration.

PORTLAND STATE UNIVERSITY
DESIGN AND CONSTRUCTION STANDARDS

- h. Provide drains at low points. Slope piping toward drains as required.
- i. Ports for corporation stops need to be located as close to the top of pipe as possible and not beyond 22.5 degrees in either direction.
- j. Provide automatic air vents at all high points of the system.

10. STEAM AND CONDENSATE PIPING

- a. Steam condensate return piping, gravity or pumped, shall be carbon steel and at a minimum schedule 80 when piping is 2 inches or less. 2 inches or greater schedule 40 carbon steel is acceptable. All piping shall have socket welded connections for piping 2 inches or less and butt welded connections for piping 2 inches or greater.
- b. Contractor to adhere to preparation and storage methods as specified by mechanical engineer.
- c. Contractor to adhere to flushing and cleaning methods as specified by mechanical engineer.
- d. Neutralize and chemically treat steam piping as specified by Portland State University chemical treatment vendor.
- e. All new installed steam header piping is designed for future conversion to 150 psig system operating at 125 psig.
- f. Expansions joints, hangers, guides and rollers need to be submitted via shop drawing and approved by mechanical engineer.
- g. Each system and piece of major equipment are required to separate isolation valves. Isolation valves should be approved by Owner.

11. CHLORINATION SYSTEM FOR POOLS

- a. Manufacturer:
Chlorine Feed System: Pulsar One or as approved by PSU Project Manager.
- b. All Seals must be Teflon. Rubber is not allowed.
- c. Use liquid chlorine for pools.

12. AIR AND DIRT SEPARATOR'S

- a. Manufacturer: Spirotech or as approved by PSU Project Manager.
- b. Consider chilled water loops, condenser water loops (closed and open), and steam condensate return systems. Required for chilled water and boiler plants.
- c. During construction blow-down debris shall be captured and removed prior to floor drain.

13. STEAM TRAPS

- a. Float and Thermostatic Steam traps are preferred, Armstrong 800 and 813, or approved equal, are required when applicable.
- b. Provide union or flanged connections at both ends.
- c. Provide gate valve and strainer at inlet and gate valve. Check valve at discharge.
- d. For major steam traps provide by-pass and blow-down valves. Major steam traps are: drip-legs, headers and major pieces of equipment.
- e. Overhead trap blow-down valve, ensure it can be operated from the ground level.

14. CHEMICAL TREATMENT

- a. Contractor shall maintain chemicals in system for 3-months after installation.

PORTLAND STATE UNIVERSITY
DESIGN AND CONSTRUCTION STANDARDS

- b. When possible, do not mix vendors and products on the same piece of equipment/station.
- c. Mount information at chemical stations shall include products is being used, chemical levels, system served, etc. O&M manuals need to be available at station.
- d. Provide adequate space for corporate stops in piping systems.
- e. Water treatment systems for boiler water systems shall be included in the Contract Documents. Systems controlled by metering pumps feeding chemical from barrels are preferred. Prefer Milton Roy metering pumps or as approved by PSU Project Manager.
- f. Boiler water steam must have a de-oxygenator (de-aerator) on the system for both large and small boilers.
- g. For new equipment the Contractor is responsible for proper cleaning, passivation and chemical treatment for the first three months after start up.
- h. Before tying into PSU system loops, contractor must collect before and after samples at different points and provide documentation to owner.
- i. Each closed loop must have a sampling port placed before and after a major piece of equipment.
- j. When sampling, first allow water run clear and then take the sample.
- k. For chemical delivery provide PEX or schedule 40 PVC piping with heat fusion connections.
- l. Chemical treatment must be considered during design. Training must be included in the bid.
- m. Preferred liquid feed for cooling towers, closed loops, boilers, fountains and pool chlorinators.
- n. Pot feeders are good for immediate adjustments and should be kept in the design.
- o. During the submittal process, contractors to complete a chemical treatment plan to PSU and design engineer for review.

15. IDENTIFICATION

- a. Comply with ANSI A13.1 for lettering size, length of color field, colors, and viewing angles of identification devices.
- b. Mechanical piping shall be labeled with flexible, vinyl film tape with pressure sensitive extra strength adhesive backing. Mechanically fastened piping is acceptable as well. Provide manufacturer label for direct bury applications when required.
- c. Include flow direction for both air and water systems
- d. If pipe is insulated, note if polypipe or plastic pipe is being used on insulation jacket.
- e. Provide a valve schedule as a part of the submittal package. Upon approval from owner, these shall be framed and installed appropriately in building mechanical spaces upon completion of project. Valves shall be tagged in the field per schedule.
- f. Provide ceiling tile labels for equipment (labeled orange) and hydronic valves (labeled Green). Labels shall be machine generated, adhesive backed with black letters, clear tape.
- g. Coordinate with facility maintenance personnel to ensure consistency with the existing system.
- h. Tag balancing valves with GPM or CFM and valve position after balancing is completed.

PORTLAND STATE UNIVERSITY
DESIGN AND CONSTRUCTION STANDARDS

- i. Identify equipment and control panels with plastic nameplates riveted to equipment body.
- j. Provide stenciled signs on each access door and housing, indicating purpose of access.
- k. Any system that has heat trace installed, the insulation shall have a label marking the heat tracing.

16. COMMISSIONING

- a. A commissioning plan and report must be submitted.
- b. Contractor shall submit one electronic and five (5) hard copies of commissioning documents to Project Manager.
- c. Commissioning agent needs to review submittals and O&M's.
- d. Commissioning agent shall coordinate training of PSU personnel.
- e. There must be a mandatory review of system/equipment within one year of building turn over.
-  f. For projects seeking LEED certification, compliance with LEED definition of "Enhanced Commissioning" must be required.
- g. Commissioning agent shall maintain an activity/action log throughout entire commissioning process.

B. HVAC SYSTEMS

1. GENERAL

- a. Ensure code required and adequate clearance for ease of accessibility to systems/equipment for repair, maintenance, or replacement.
- b. All HVAC systems shall be installed per code, ASHRAE, SMACNA, and industry standards.
- c. Identify all HVAC piping and equipment with stamp tag and flow direction. Color of label shall follow Code.
- d. Ensure as much as possible adequate clearance for ease of accessibility to systems/equipment for repair, maintenance, or replacement.
- e. Commissioning, testing, and balancing of air systems shall be performed prior to the conclusion of each project.
-  f. All systems shall be designed to optimize energy efficiency, improve indoor environmental quality, and assist in achieving credits in the LEED rating system. Refer to Energy Conservation Guidelines (Appendix 26.1).
- g. The minimum required SEER rating's for new HVAC equipment shall comply with the Oregon Energy Code, PSU strives to exceed code so the project team shall provide equipment suggestions that accomplishes this.
- h. All new HVAC equipment shall be charged with refrigerant / hydrochlorofluorocarbons (HCFC) that adhere to the Environmental Protection Agency (EPA) requirements and phase out protocols. In 2020, R-22 is scheduled to be phased out and in turn should not be specified for new equipment. In 2030, R-123 is scheduled to be phased out and new HVAC equipment whose life span extends past 2030 shall not be specified with R-123.

2. HANGERS, SUPPORTS AND ANCHORS

PORTLAND STATE UNIVERSITY
DESIGN AND CONSTRUCTION STANDARDS

- a. Hanger rod shall be steel, galvanized, threaded on both ends, or continuously threaded. Hanger spacing shall follow guidelines per the Oregon Mechanical Specialty Code and SMACNA standards.
 - b. Duct stiffeners are preferred over additional supports in the appropriate locations. Stiffeners shall be installed outside of the airstream.
 - c. Seismic bracing and vibration isolation requirements shall be analyzed and verified by a specialized design professional.
3. TESTING, ADJUSTING AND BALANCING
- a. Coordinate testing and balancing (TAB) work with other trades when applicable (e.g. fire life safety, BAS controls, commissioning agent, etc).
 - b. TAB provider shall be NEBB or AABC certified.
 - c. TAB shall be performed under simulated normal building operating conditions with doors and windows closed, ceiling's installed, etc.
 - d. New filters shall be installed before balancing and again prior to handover to owner.
 - e. Prior to TAB, examine systems and system components and verify their operation and accessibility.
 - f. Systems shall be flushed of debris prior to balancing. Pete's plugs are required across major water balancing components.
 - g. Provide one electronic copy, and 3 hard copies of the balancing report. Include equipment calibration reports.
 - h. Mark on volume balancing dampers the final balancing settings/position.
 - i. TAB shall be equipped with appropriate to prefer air/water balancing PSU control systems.
4. INSULATION
- a. Provide flexible glass fiber, commercial grade insulation with factory applied reinforced aluminum foil jacket. Provide ductwork insulation accessories for complete installation.
 - b. All ductwork installed outside shall be internally insulated.
 - c. Contractor shall make shop available for owner review of duct fabrication and duct liner installation.
 - d. All fan enclosures shall be insulated.
 - e. All supply, return, and outside air ductwork shall be insulated.
5. DUCTWORK
- a. All ductwork shall be manufactured and installed per SMACNA standards.
 - b. Seal joints and reinforce ducts to prevent buckling, vibrations, and unnecessary noises. Fabricate ductwork in order to eliminate all sharp corners.
 - c. Fabricate and install ductwork fittings with the least amount of pressure drop.
 - d. Duct systems constructed using duct board will not be accepted.
 - e. Use Pittsburg clamping system or as approved by PSU Project Manager.
 - f. Flex duct longest lengths shall be 5 feet prior to termination at diffuser.
 - g. Ductwork used to exhaust chemical fume hoods and special exhaust systems must be welded and stainless steel or PVC coated.

PORTLAND STATE UNIVERSITY
DESIGN AND CONSTRUCTION STANDARDS



- h. Supply air and general exhaust ductwork shall be galvanized steel.
 - i. The Contract Documents shall require that new duct systems are cleaned and inspected for cleanliness prior to energizing air-handling equipment.
 - j. Label all ductwork based on its service (e.g. supply air, return air, hazardous exhaust, general exhaust, etc).
 -  k. At the beginning of any remodeling work, cover all return air grilles with filtering material to prevent accumulation of dust in existing duct system.
 - l. If duct work is installed but not in use, it shall be temporally sealed for protection.
6. AIR DUCT ACCESSORIES
- a. Manufacturer: Ruskin, Greenheck, Tamco Air-Foil Control dampers or as approved by PSU Project Manager; all actuators shall be Siemens, Belimo or approved equal
 - b. Volume dampers shall be no lighter than 18 gauge and reinforced to prevent vibration.
 - c. Control dampers shall be opposed blade and air foil type. For exhaust and outside air dampers, blade edges must be sealed to prevent leakage. Leakage testing shall be required to ensure compliance with manufacturer's performance criteria.
 - d. Dampers that are greater than 25 ft sq. in area shall be installed in two or more sections.
 - e. Install safety screen where fan inlet/outlet or moving parts are exposed.
 - f. Install flexible duct connectors to air handling units. Provide weather guard when installed outside.
 - g. All dampers and their accessories shall be accessible for future repair/replacement. Access points shall be visibly labeled from occupied space.
7. AIR OUTLETS AND INLETS
- a. Manufacturer: Titus, Price, or as approved by PSU Project Manager.
 - b. Provide gooseneck or rain cap to prevent water intrusion for outdoor installation.
 - c. In moist environments (e.g. locker rooms), provide aluminum construction and stainless steel mounting hardware.
 - d. Provide integral balancing dampers where balancing dampers are not already specified.
 - e. For door louvers, minimum steel thickness is 20 gauges.
8. FUME HOODS
- a. When there is more than one fume hood in a room, perform backflow verification test (i.e. if one fan shuts off ensure no backdraft).
 - b. New fume hoods shall be standard products from a manufacturer, acceptable to laboratory use, and specifically approved by the PSU Environmental Health and Safety. All fume hood designs should demonstrate containment of tracer gas less than 4.0 AM 0.05 according to ASHRAE Test Standard 110-1995. *AIHA Z9.5-1995*.
 - c. All hoods shall be equipped with sash stops on vertical rising sashes allowing the sash height to be set at 18 inches during routine use, unless otherwise advisable.
 - d. High performance fume hoods shall be used, unless otherwise advisable. High performance hoods shall have a 60 FPM face velocity at 18" sash height.
 - e. In those cases where high performance fume hoods cannot be used, constant air volume hoods with bypass air openings shall be used. The bypass air opening shall progressively uncover as the sash is lowered to its lowest point.

PORTLAND STATE UNIVERSITY
DESIGN AND CONSTRUCTION STANDARDS

- f. New hoods should be mounted on a chemical storage cabinet.
- g. Interior fume hood surfaces shall be rigid, safe, and constructed of corrosion resistant, non-porous, non-combustible materials, appropriate for the intended use.
- h. The interiors of hoods shall have smooth and impermeable interior surfaces with rounded corners. Interior surfaces shall be free of cracks and crevices to allow easy cleaning.
- i. Laboratory hoods shall be provided with a means of containing spills.
- j. A horizontal bottom airfoil inlet at the front of the hood shall be provided.
- k. The rear and top interior of the hood shall be furnished with baffles to provide at least two, preferably three, slots. Baffles should be continuous.
- l. A quantitative airflow sensor and an audible and visual alarm shall be permanently installed and located so that the display is visible to the user from the front of the fume hood.
- m. Light fixtures shall be of the fluorescent type and replaceable from outside the hood. Light fixtures shall be displaced or covered by a transparent, impact resistant, vapor tight shield to prevent vapor contact. Hood lighting shall be provided by UL listed fixtures. If located within the hood interior, the fixtures shall meet the requirements of NFPA 70 (National Electrical Code) sections appropriate to hazardous atmospheres.
- n. The valves, electrical outlets, and switches for utilities serving hoods shall be placed at readily accessible locations outside the hood. All shut-off valves shall be clearly labeled. Each new fume hood utilities shall have their own shut off valves prior to fume hood.
- o. Plumbing (e.g., vacuum lines) should exit the sides of the fume hood and not the bench top.
- p. Post instructions on how to use the hood per chemical requirements for enclosed spaces and fume hood manufacturer recommendations.
- q. When cup sinks are provided they are to be integral to the fume hood and provided with backflow prevention. Cup sinks to drain to acid waste system.
- r. All fume hoods shall be labeled with local service representative.

C. MECHANICAL EQUIPMENT

1. GENERAL

- a. Ensure code required and adequate clearance for ease of accessibility to systems/equipment for repair, maintenance or replacement.
- b. All equipment to be installed per code and industry standard.
- c. All equipment to be commissioned upon completion of project.
-  d. Vibration and noise must be considered in design. Install systems where it causes the least disturbance. Otherwise use noise and/or vibration dampening.
- e. For mechanical equipment located outdoors, the design shall provide features to facilitate winterization of such equipment.
- f. If equipment is elevated off of roof, provide platform in order to meet code required access and clearances.
-  g. Mechanical room floors shall be protective, water resistant, and coated and sealed with a sustainable product.
- h. Contractor shall provide required equipment data for PSU deferred maintenance software.

PORTLAND STATE UNIVERSITY
DESIGN AND CONSTRUCTION STANDARDS

- i. Provide DDC controls and program into PSU building automation system (BAS) for all mechanical equipment.
 - j. Provide concrete housekeeping pads when applicable.
 - k. Ensure that replacement parts and components are available locally.
 -  l. All systems shall be designed to optimize energy efficiency, improve indoor environmental quality, and assist in achieving credits in the LEED rating system. Refer to Energy Conservation Guidelines (Appendix 26.1).
 - m. Provide written energy control procedures (provisions for lock-out tag-out) for any new equipment installation. When making modifications to existing equipment, require revisions to the written energy control procedures.
2. PACKAGED ROOF TOP / SPLIT SYSTEM - HVAC UNITS
- a. Manufacturer: Trane, Carrier, Reznor, McQuay/Daikon, or as approved by PSU Project Manager.
 - b. Split system and stand-alone condensers shall be tube and fin type.
 - c. Gas heat is preferred over electric strip heat.
 - d. Provide NEMA 3R enclosure for VFD's, electrical/controls components, control panels, etc.
 - e. Contractor shall provide required structural anchorage per structural engineer requirements. Provide vibration isolation in order to meet specified structural and/or noise/vibration criteria.
 - f. Provide walk-off pads around equipment on roof.
 - g. Roof curbs shall be pre-manufactured and provided by HVAC unit manufacturer.
 - h. Ensure that roof warranty will be maintained/adhered to.
 - i. Outside air intakes need to be provided with water guard and bird screen.
 - j. City of Portland design review requirements shall be considered during design.
3. VARIABLE FREQUENCY DRIVES (VFD) AND MOTORS
- a. Manufacturers:
 - i. VFDs: ABB or as approved by PSU Project Manager.
 - ii. Motors: Baldor or as approved by PSU Project Manager.
 - b. VFDs shall have no bypass and be enclosed in NEMA 3R rated waterproof enclosure if installed outside.
 - c. Motors shall be high efficiency, inverter duty rated, and must have shaft grounding provided by factory when a VFD is installed.
 - d. Perform an AMP draw after installation, results shall be included in start-up report and reported to owner.
 - e. Install disconnect within line of sight of VFD.
 - f. Design equipment so that load does not cause motor to run in its service factor. Maximize amperage of motor.
 - g. If replacing a motor, stay within engineering limits of the equipment.
 - h. Motor must be high efficiency and waterproof if in an exterior location.



PORTLAND STATE UNIVERSITY
DESIGN AND CONSTRUCTION STANDARDS

- i. Bearings to be serviceable, accessible, and grease-able. Grease shall be a sustainable product.
4. CUSTOM AIR HANDLING UNITS
- a. Manufacturer: Hunt Air, McQuay/Daikon, Trane, York, or as approved by PSU Project Manager.
 - b. Require close coordination between air handling unit manufacturer, structural engineer, mechanical engineer, electrical engineer, acoustical engineer, and architect to ensure that unit structural support and mechanical and electrical connections are fully covered and responsibilities are fully defined.
 - c. Units having arrays of multiple small fans are encouraged.
 - d. HVAC fans shall be high efficiency when applicable.
 - e. Allow clearances to pull shaft, motor, and other fan components.
 - f. A light and receptacle shall be provided in enclosure. For outdoor units, provide adequate lighting and access for service and maintenance needs.
 - g. Roof off of enclosure to shed water. Provide floor drain in enclosure and route to roof drain.
 - h. If AHU is shipped in multiple sections, provide water proof joints between sections.
 - i. For HVAC fans, provide pressure safety switch on discharge side of fan in order to protect equipment.
 - j. Provide heat recovery when viable.
 - k. Provide two position valves at all coils for shut-off. Control valves shall not be used for shut-off.
 - l. Provide signage at each access door into air handler that notifies personnel of potential safety hazard. Access door shall be lockable.
 - m. Provide filter bank. All filters shall be MERV 13 rating. Filters to be replaced prior to building turnover to PSU.
 - n. For AHU control dampers all shafts/linkages to be metal. No plastic parts.
5. SPECIALIZED EXHAUST SYSTEMS
- a. Manufacturer:
Lab Exhaust: Greenheck, Strobic Air, or as approved by PSU Project Manager.
 - b. Fans exhausting laboratory fumes shall be designed as such and shall provide high velocity discharge that sends plume into atmosphere.
 - c. Exhaust fans shall be designed to exhaust the required media (e.g. kitchen/grease fumes, paint fumes, etc). Fan material and components shall be spark proof when applicable.
 - d. All laundry exhaust systems shall be installed with lint filter and constructed per Oregon Mechanical code.
 - e. All painting application shall be installed with industry standard paint booth and specialized HVAC system.
 - f. Wood shops shall be equipped with appropriate dust collection system, specialized exhaust system, and fire suppression requirements.
 - g. All specialized exhaust fans shall be controlled, monitored, and alarmed via building automation systems.

PORTLAND STATE UNIVERSITY
DESIGN AND CONSTRUCTION STANDARDS

- h. Obnoxious/ Smelly fumes shall be exhausted from building occupants and general public. Exhaust fan discharge shall be directed so that odors are not detected by occupants.
6. AIR TERMINAL UNITS
- a. Manufacturer: Titus, Trane, Siemens (lab applications only) or as approved by PSU Project Manager.
 - b. Heavy duty bearings shall be specified for fan terminal units.
 - c. No flex on the inlet of a terminal box.
 - d. Provide working clearances around terminal unit and piping components.
 - e. Terminal Unit shall only be supported from building structure.
 - f. All air terminal units must have disconnect for fan powered units within line of sight of control panel.
 - g. Provide pipe kits, drain pan (when applicable) and flexible connections to re-heat coil. Condensate pipe shall be copper and properly sloped to drain. No quick connect fittings.
 - h. Terminal units shall be labeled at drop ceiling.
 - i. Provide fume hood exhaust, general exhaust, and supply air when air terminal units are installed in a lab environment.
 - j. All entering and leaving ductwork shall meet manufacturer's requirement to reduce turbulence and allow accurate measurement and control.
7. CONDENSING AND HEATING BOILERS
- a. Manufacturer: RayPak, Cleaver-Brooks, Aerco, AO Smith, Bradford White, KN or as approved by PSU Project Manager.
 - b. When applicable, review design with boiler inspector. Contractor is required to provide final boiler permit and inspections from boiler inspector.
 - c. For domestic water heating, install separate back up electric hot water heater system when steam domestic hot water heater is the existing source.
 - d. For condensing boilers, a condensate neutralization station to be provided and piped to appropriate drain.
 - e. Provide isolation pad between concrete and boiler to prevent electrolysis.
 - f. Condensing boilers shall be piped reverse return for multi-unit installations.
 - g. Boilers need to be UL listed and stamped accordingly.
 - h. Boilers shall be equipped with a dedicated city water make-up with gate valve in order to fill up boilers quickly.
 - i. Boilers shall be installed with hose bib in order to drain down.
 - j. Provide seismic restraint/anchorage per structural engineer requirements.
 - k. Burners shall be high efficiency (85%-98% depending on application) and linkage-less when available.
 - l. Flues shall terminate above roof line and be provided with rain cap.
 - m. Operating pressure of all system components shall be consistent throughout (e.g. storage tanks, condensate tanks, expansion tanks, T&P valves, etc).
 - n. Emergency electrical shut-off to be clearly labeled, red, and installed at the main point of egress. Provide cover.

PORTLAND STATE UNIVERSITY
DESIGN AND CONSTRUCTION STANDARDS

8. CENTRAL PLANT BOILERS

- a. Manufacturer: Cleaver Brooks, Hurst, Johnston, Burnham, Miura, or as approved by PSU Project Manager.
- b. Boilers shall be UL listed and stamped accordingly. Boilers shall be constructed for 150 psi operation; actual operation shall be 15 psi.
- c. Boiler shall be provided with economizer.
- d. Boilers shall run off of natural gas and No. 2 oil.
- e. Tubes shall be cleanable from either front or back of boiler.
- f. OSHA-approved platforms and ladders shall be provided to access boiler.
- g. Burners shall have a minimum standard efficiency of 85%. When available, burners shall be linkage-less and have a parallel positioning system.
- h. Emergency electrical shut-off shall be clearly labeled red and installed at the main point of egress. Provide cover.
- i. Boiler(s) to be provided with control panel which can be controlled via PSU BAS system.
- j. Boiler shall be equipped with low NOx control, O₂ trim system, and VFD on blower.
- k. Central plant boilers shall operate in conjunction with a spray type de-aerator system. De-aerator tank shall be installed with magnesium rod to prevent corrosion.
- l. Dirt separator shall be installed on central plant condensate return systems.
- m. Wet-back design is preferred.
- n. Boiler shall be seismically anchored per structural engineer's design.
- o. In multiple boiler installations provide means to prevent carry over via the main steam header.
- p. Chemical treatment equipment and program to meet PSU standards.

9. HEAT EXCHANGERS

- a. Heat exchangers shall be properly rated for the flow and the media.
- b. Shut-off valves shall be directly up/downstream of all inlets and outlets.
- c. Provide isolation drain down valves.
- d. Where possible, provide a hose bib and floor drain near plate and frame heat exchangers in order to clean and service.
- e. Heat exchanger shall have strainer ahead of inlets that meets manufactures recommendations.

10. PACKAGED WATER CHILLER

- a. Provide Glycol or heat trace and low ambient control for outdoor installations.
- b. When viable, provide extended warranty on compressor.
- c. Chemical treatment equipment and program shall meet PSU standards.
- d. Packaged water chiller shall be provided for specialized purpose (e.g. academic research, server room cooling, etc). Campus chilled water shall be used in all other cases and when available.
- e. Authority having jurisdiction shall review and approve the use of domestic city water for cooling needs. If approved, this water shall be metered.

PORTLAND STATE UNIVERSITY
DESIGN AND CONSTRUCTION STANDARDS

11. CENTRAL PLANT CHILLER

- a. Manufacturer: Trane, McQuay/Daikon, Carrier, or as approved by PSU Project Manager.
- b. Provide 10-year extended warranty on compressor.
- c. Chemical treatment equipment and program to meet PSU standards
- d. For large chillers, provide a jib crane, rail system, or other in order to provide maintenance to chiller.
- e. A refrigerant Leak Detection System shall be required.
-  f. Refrigerant shall be specified to assist in achieving Energy and Atmosphere credits in the LEED rating system.
- g. Provide adequate clearances in order to clean tubes on both ends of chiller.
- h. Provide dirt/air separator.

12. COOLING TOWERS

- a. Manufacturer: Evapco or as approved by PSU Project Manager.
- b. Provide stainless steel basin construction. Supply sump heater for basin if tower is in year round operation.
- c. Cooling tower to be provided with VFD and a vibration limit switch. Provide ultra-quiet fan operation accessory when noise is a consideration.
- d. Provide side stream filter.
- e. Provide fan guard, safety railings, and ladder from grade to fan deck.
- f. Design access to the basin and means to pull the motor.
- g. Prior to specifying chemical treatment systems, consult with PSU Project Manager. See Section 23.A.14 for additional information.
- h. Provide jib arm to pull the motor.
- i. Cooling tower and cooling loop shall be designed to match chiller capacity.
- j. Open towers shall be located external to buildings. Roof-mounted units are preferred.

13. PUMPS

- a. Manufacturer: Paco, Bell and Gossett, BFS Industries (Condensate Pumping Stations), or as approved by PSU Project Manager.
- b. For chilled and condenser water pumps, pump seals shall be Unitized EPR/SiC/SiC. Rated for 1000 ppm undissolved solids.
- c. Impellor shall be silicon bronze, fully enclosed, keyed to shaft. Trim impeller to maximum flow rate without overloading the motor.
- d. Shaft shall be stainless steel.
- e. Condensate pumping stations shall come equipped with a welded steel tank. Motors are not required to have a VFD. Ensure means to fully drain tank.
- f. Sump pumps shall be equipped with a mechanical float and alarmed for high levels.
- g. Sewage injection pumps shall have a grinder on the impeller.
- h. Submit documentation that pumps are in proper alignment.
- i. Piping needs shall be independently supported prior to pump installation; the pump should not bear any of the weight.

PORTLAND STATE UNIVERSITY
DESIGN AND CONSTRUCTION STANDARDS

- j. Provide isolation valves, check valves, and unions or flanges for maintenance and replacement purposes.
14. IDENTIFICATION FOR MECHANICAL EQUIPMENT
- a. Provide stickers for identification rather than stenciling.
 - b. All above ceiling equipment shall be marked using label tape markers affixed to the ceiling grid, or similar methods.

D. MECHANICAL INSTRUMENTATION AND CONTROLS

1. GENERAL

- a. PSU's centralized control system is Siemens Apogee. All new control systems shall interface accordingly.
- b. Contractor shall participate and provide a 50% and a 90% review of control drawing's and devices. As-builts shall be delivered in PDF and AutoCAD format.
- c. All new work shall comply with NEC and all local codes.
- d. Throughout the creation of the instrumentation and controls construction specifications, contact PSU controls team for review.
-  e. All systems shall be designed to optimize energy efficiency, improve indoor air quality, and assist in achieving credits in the LEED rating system. Refer to Energy Conservation Guidelines (Appendix 26.1).
- f. The design of the BAS shall support networking of operator workstations and Building Controllers. The network architecture shall consist of two levels, an Ethernet based primary network for all operator workstations, servers, and primary DDC controllers along with secondary Floor Level Networks (FLN) for terminal equipment application specific controllers. **At the Floor Level BACnet shall only be used for third party devices.**
- g. Control systems that use BACnet ms/tp field bus will not be approved.

2. COMMUNICATION

- a. Wireless devices are not preferred but shall be approved by PSU Project Manager on a case by case basis.
- b. Communication to 3rd party devices shall be BACNET. A third party device that is P1 or FLN compatible is acceptable.(e.g. Onicon BTU meters, ABB VFD's)
- c. The design of the BAS shall support networking of operator workstations and building controllers. The network architecture shall consist of three levels: Management Level Network (MLN) for all operator workstations and servers, Building Level Network (BLN) for primary DDC controllers, and Automation Level Network (ALN, aka FLN) for terminal equipment application specific controllers.

3. PROGRAMMING

- a. In lead/lag scenarios when a start command is issued and the equipment fails to run, do not remove the start command from the failed equipment.
- b. Limit the use of the resident point, "\$loc's". When they are used, create a virtual point that corresponds to the value of the "\$loc".

4. GRAPHICS

- a. All points shall be shown on graphics.

PORTLAND STATE UNIVERSITY
DESIGN AND CONSTRUCTION STANDARDS

- b. On graphics of major/critical equipment, provide a direct link to the sequence of operations and IOM. For terminal equipment and application specific controllers, provide a link to the application manual.
-  c. Wherever feasible, online dashboard applications must be considered in new buildings, renovations, and remodels. If these applications are used, the system shall be web based and not directly tied into PSU's network.
- d. All PC monitors shall be of flat panel type and shall support a minimum display resolution of no less than 1280 x 1024 pixels. The display shall have a minimum of 19" visible area in diagonal measurement. Separate controls shall be provided for color, contrasts and brightness. The screen shall be non-reflective.

5. DEVICES

- a. All actuators shall be electronic. Pneumatic devices must be pre-approved.
- b. For chilled water and condenser water flow sensing, no turbine type meters are allowed. Provide Onicon Model F(B)-3500 or as approved by PSU Project Manager.
- c. All enclosures shall be labeled with a minimum of node name, system name, and power source.

6. LOW VOLTAGE WIRING

- a. Provide color coded wiring per OIT Standard (appendix 27.1). Wiring shall be labeled at each end with point name and address.
- b. Contractor shall provide all supports for wiring. Wiring can't be supported from existing conditions (e.g. Ceiling grid hangers, sprinkler pipe hangers).
- c. Communication wiring shall be 24 AWG, twisted pair, shielded, and low capacitance.
- d. Power for BAS shall have dedicated circuits.
- e. All systems requiring interlock wiring shall be hardwired interlocked and shall not rely on the BAS programming to operate (e.g. emergency generator to fuel oil pump interlock, emergency generator damper interlock, etc).
- f. All safeties shall be hardwired. Safeties shall not rely on the BAS to act and shutdown systems upon detection of a failure, safety limit, or alarm.



7. COMMISSIONING

- a. Provide point to point check out sheets prior to commissioning activities verifying functionality of each device.
- b. The contractor's technical support team (including programmer) personnel shall be consistent throughout the project including commissioning.
- c. After commissioning remove all unnecessary trending.

END OF SECTION

PORTLAND STATE UNIVERSITY
DESIGN AND CONSTRUCTION STANDARDS

SECTION 26 - **ELECTRICAL**

A. COMMON WORK RESULTS FOR ELECTRICAL

1. GENERAL

- a. All work shall be performed per the current adopted National Electric Code (NEC/NFPA70) and current enforceable Oregon specialty codes.
- b. Conduits feeding any branch shall have maximum of 40% fill.
- c. Each device box shall have grounding pigtails.
- d. Whenever possible, all junction boxes shall be readily accessible per NEC definition, labeled with circuit identifier and origin.
- e. All devices, equipment and material within the scope of work shall be affixed with a PSU approved permanent label identifying panel of origin and circuit number.
- f. All electrical distribution busses and boards shall have copper (CU) bussing. AL plated buss & AL wound transformers are prohibited.
- g. All circuit breakers shall be bolt-on type, where applicable.
-  h. All EMT fittings of set screw types shall be steel with recycled-content.
- i. Flexible MC cable is not allowed in any new constructed building or major remodels, with the exception for lighting fixtures up to 6'-0" max.
- j. Hardpipe is required exiting all panel boards.
- k. For new buildings and major remodels, install full size panel equipped with 42 circuit breakers at a minimum.
- l. All low voltage wiring shall be independently supported using appropriate pre-manufactured supports.
- m. Underground and underslab ducts and raceways shall be rated for the type of installation.
- n. An overcurrent protective device coordination study, arc flash study, and arc flash assessment is required for all new construction and major renovation.
- o. All new services are preferred to be 480/277V.
- p. Any new service shall have (1) adjustable Main OCPD, where applicable. The single main to have adjustable trip settings.
- q. All electrical control equipment, including lighting control panels (master, satellite and/or modules) shall not be installed above a finished classroom ceiling. If design/installation cannot meet this requirements, contact PSU CPC.
- r. All OCPD's shall be rated for the applicable KAIC. Minimum KAIC rating allowed in most installations shall be 22KAIC.
- s. Provide a complete grounding system design including any schematics, risers and details. Specifications and drawings shall include detailed requirements (sizes, quantities, conduits, etc.) of the grounding system. Grounding design shall include main service, supplemental, and equipment grounding requirements. Specifying grounding requirements by referencing a code is prohibited.
- t. Contractor(s), Designer(s) and Engineer(s) are responsible for addressing all design review comments to the satisfaction of PSU in order to assure the continued reliability of all power distribution systems.

PORTLAND STATE UNIVERSITY
DESIGN AND CONSTRUCTION STANDARDS

- u. Minimum conduit size for power circuits shall be 3/4 inch. Minimum conduit size for control wiring shall be 1/2 inch. Conduit crossing building expansion joints shall have expansion provision with grounding continuity.
- v. Where applicable in new construction, all new electrical distribution equipment shall allocate 20% spare capacity (electrically & physical space) for future growth. If 20% is not obtainable during design phase(s) contact PSU CPC.
- w. Proper ventilation and cooling shall be provided at locations where transformers are installed to prevent temperature in the room to rise above 75 degrees F.
- x. All conduits shall be hidden in walls, floors, or ceilings where applicable.
- y. For electrical box acoustics, provide sound insulation and gasketing at switch and outlet box locations at conference rooms and executive offices. Boxes in walls shall be staggered and not back to back.
- z. During any construction that requires the use of electrical extension cords, a GFCI surge protector must be in-line & in use, between the source and the load. Defected or clearly damaged extension cords are not allowed for use on campus.
- aa. All low voltage power distribution transformers shall meet NEMA TP-1 at a minimum.
- bb. During installation of all electrical distribution equipment/components/devices the contractor is responsible to verify, test, record, and document that all conductive electrical connection points are properly secured and seated per manufacturers recommendations. Completed installation should be free of all defect.
- cc. All equipment control wiring shall be installed in a control raceway. Power (Voltage/Current) conductors shall same control raceway. The only exception is if the control wiring sources the same load as the power conductors the insulation of the conductors are identical.
- dd. During the design process, design team to provide a true life cycle cost of equipment if requested by PSU.
- ee. If a project requires a new or an altered existing (30% or more as determine by PSU) piece of electrical distribution equipment such as Services, Switchboards, Distribution Boards, Panel Boards, Busways, Load Centers, the design team is responsible to perform NFPA 70 requirements as it pertains to Arc Flash, Available Fault and TCC. PSU will require each requirement to be provided in electronic format (.dez, .dwg & .pdf) and hard copy.
- ff. If a project requires an existing or a new piece of electrical distribution equipment such as Services, Switchboards, Distribution Boards, Panel Boards, Busways, Load Centers to be altered/installed, the design team is responsible to produce an updated warning/hazard labels to applied to such equipment per current NFPA 70 & 70E.
- gg. If a warning/hazard label is required to be installed, apply label on the front face of the specified piece of equipment. The only exception to this rule is if such equipment is in a common corridor/space. If contractor is unsure, contact PSU and submit an RFI.
- hh. If a warning/hazard label is required to be installed on an existing piece of equipment, contractor shall remove all other warning/hazardous labeling and apply new label on the front face of the specified piece of equipment. The only exception to this rule is if such equipment is in a common corridor/space. If contractor is unsure, contact PSU and submit an RFI.
- ii. Provide written energization, de-energization and testing electrical control procedures (provisions for lock-out tag-out) for any new equipment installation(s). When modifications to existing equipment, require revisions to any written electrical control procedures.

**PORTLAND STATE UNIVERSITY
DESIGN AND CONSTRUCTION STANDARDS**

- jj. All electrical work to be performed within the scope of work shall only occur while all equipment is de-energized. Prior to any electrical work to be performed, the Electrical contractor is responsible to perform a site assessment of all energized electrical equipment within the same distribution system as it pertains to the scope of work. In certain situations, where existing facilities and systems lack documentation, the electrical contractor will be responsible to implement additional safety measures when performing electrical work, including but not limited to grounding straps, protective blast barriers, etc. If the electrical contractor cannot de-energize the equipment or system to perform the work, the electrical contractor is required to contact PSU PM.
- kk. Prior to performing any electrical work, the contractor is required to provide a safety plan and pre-task plan to PSU PM and PSU EH&S for review and approval.

2. IDENTIFICATION

- a. Provide label trim plates.
- b. Color-code for different systems and by voltage:
 - i. Black, Red, Blue - 120/208
 - ii. Brown, Orange, Yellow - 277/480
 - iii. Gray, White - Neutral
- c. Where a color system is in place, continue the same pattern as is.
- d. Label all electrical distribution equipment such as switchgear, distribution and panel boards to match plans (Phenolic Labels).
- e. Provide schedules for all electrical distribution equipment such as Switchgear, Distribution and panel boards.
- f. All electrical distribution equipment enclosures, including disconnects, shall be affixed with a label identifying where that piece of equipment is being sourced from. The label should include name of source, type of source and location of source.
- g. All naming to follow table below:

ELECTRICAL EQUIPMENT LABELING IDENTIFICATION									
Facility Identifiers		Source Type	Voltage(kV)	Eqpt Type		Level/Flr	RowColumn (AlphaNumber)	Series	
Campus	BLDG	Normal :N	12.47 :6	SWGR/Bldg Service	:S	Sub Basement	:01	Row D Column 2 :D2	:A
XCXP	CLSB-	Emergency :E	0.48 :4	Distribution Board	:B	Basement	:0	----	:B
	HGCD-	Uninterrupted :U	0.24 :D	Panel Board	:P	First Floor	:1		:C
	NASC-	Stand-By :S	0.208 :2	Load Center	:L	Second Floor	:2		----
	CHXP-	Loop :L	XFMR :T	Busway	:W	Third Floor	:3		
	ABXP-			UPS	:U	Fourth Floor	:4		
	SBAP-			Disconnect	:X	Mezzaine	:M		
	----			VFD/ASD	:V	Roof	:R		
----			Motor Control Centr	:M					
			ATS (A) MTS (M)	:A					

Examples : In Cramer Hall locating a distribution board, panel board and transformer.
 >400A Distribution board is on the first floor at row a and column 1, emergency source of 480V. : CHXP-E4B1A1
 A second sub-fed 400A panel board, normal power, 208V, located on third floor, row 6 column B : CHXP-N2P3B6-B
 A 45kVA, 480-208/120 xfmr sourced by UPS power, located in sub-basement at row F, column 5 : CHXP-UT01F5

Refer to Campus map online for all current building abbreviations.

3. ELECTRICAL DISTRIBUTION EQUIPMENT

- a. Manufacturer: Eaton, Square D, or as approved by PSU Project Manager.
-  b. Sub-metering of main building switchgear is required. Provide connection to PSU building automation system. Sub-metering shall be considered for other pieces of electrical gear in which it provides coverage for large portions of the building. On a project by project

PORTLAND STATE UNIVERSITY
DESIGN AND CONSTRUCTION STANDARDS

basis, CPC Director, FPM Assistant Director of Operations and Maintenance, CPO Utilities Management Director, Director for Housing and Residence Life, and Executive Director for Planning, Construction, and Real Estate will meet to determine sub-metering requirements.

- c. For any transformer and switch enclosures, provide window to be located in the cabinet to allow for performance of infrared testing.
 - d. In certain cases, PSU will require double ended switch gear for the building's main 120V, 208/230V, 460V/480V electrical infrastructure.
4. WIRING DEVICES – RECEPTACLES, SWITCHES
- a. Provide commercial grade receptacles in most cases. PSU maintains numerous types of buildings. If building type/space is not clear, contact PSU.
 - b. Provide commercial grade switches in most cases. PSU maintains numerous types of buildings. If building type/space is not clear, contact PSU.
 - c. Provide stainless steel covers/faceplates for new construction in most cases. PSU maintains numerous types of buildings. If building type/space is not clear, contact PSU.
 - d. For all medium voltage, cabling partial discharge sensors shall be installed. At the conclusion of installation, a partial discharge report shall be provided.
 - e. Provide GFCI devices where required by code.
 - f. Provide AFCI devices where required by code.
 - g. If not feasible or prior approval by PSU, a combination of circuit breakers and fuses within the same electrical distribution system is not permissible. An exception includes primary voltage services, MCC's, and UL classified fuses as required for time delay and limitation requirements of the application.
5. AUTOMATIC TRANSFER SWITCHES
- a. Manufacture: ASCO, Eaton or as approved by Project Manager.
 - b. For emergency systems, design to match generator demand load, in compliance with NFPA guidelines.
 - c. For medium voltage infrastructure, design to meet building load(s). Ideally, transfer shall be seamless, with no power bumps. Consult with PSU.
 - d. All transfer switch status shall be wired into PSU building automation system.
 - e. Provide automatic transfer switches with maintenance bypass isolation.
6. Generators
- a. Manufacturer: MTU, Generac, CAT or as approved by Project Manager.
 - b. When installing a EPSS (Optional or Stand-by), the source shall be separately derived.
 - c. When installing a single (Optional or Stand-by) generator, provide a breaker at the generator. If multiple or parallel generators are being considered during design consult with PSU.





B. LIGHTING

1. GENERAL

-  a. Daylighting shall be the primary lighting strategy with electric lighting supplementing, as required by code.





PORTLAND STATE UNIVERSITY
DESIGN AND CONSTRUCTION STANDARDS

- b. Daylight sensors shall be installed to control light fixtures as required by code.
-  c. All lighting installations must meet or exceed Oregon Energy Code.
-  d. All light bulbs and fixtures shall be ENERGY STAR-rated whenever possible. Prefer high-efficiency florescent lights and fixtures. Refer to Energy Conservation Guidelines (Appendix 26.1).
-  e. Provide and install all code required minimum electrical and lighting items including, ADA door bells, occupancy sensors, GFI outlets, emergency lighting, illuminated exit signs, alarms, and strobes. Refer to Energy Conservation Guidelines (Appendix 26.1).
-  f. All purchased fluorescent lighting shall meet the LEED credit for Reduced Mercury in Lamps. The maximum target for the overall average of mercury content in lamps is 70 picograms per lumen-hour or less.
- g. All mounting heights shall be per ADA standards.
- h. MC Cable is acceptable for lighting fixtures subject to the same limitations outlined in Section 26.A.1.p.
- i. Provide schematics, schedules, relay (sizes & quantities) and clear intent for all lighting controls as applicable.
- j. Occupancy sensors for lighting are recommended in all areas where appropriate according to use patterns.
- k. In any new construction, renovation and/or remodel that replace lights within offices, conference rooms or classrooms $\geq 1000\text{sqft}$, 75% of the total design/installation area (if not all) shall be LED type(s).
- l. In any new construction, renovation and/or remodel that replace lights within corridors and/or common areas ($\geq 1000\text{sqft}$), all new light designs/installations shall be LED type.
- m. In any new construction, renovation and/or remodel that replace lights within parking structures, utility rooms and system facility areas/spaces that are considered to be continuous operation ($\geq 3\text{hrs}$), all new light designs/installations shall be LED type.

2. INTERIOR LIGHTING FIXTURES

-  a. Prefer indirect type LED, unless another solution is determined appropriate for the space and does not exceed the energy use of LED fixtures.
- b. Chose the most energy and cost effective option for individual applications.

3. LIGHTING CONTROL DEVICES

- a. Manufacturer: nLite, Watts Stopper or as approved by PSU Project Manager.
-  b. Local occupancy sensors are required. They should be located adjacent to doors and should be the primary control for any energy reduction measures.
- c. Segregate zones/areas as small as suites or rooms.
-  d. Individual light control systems (task lighting) shall be evaluated in an open office setting. Consider integrated and performance-based approach for evaluation.

4. NETWORKING LIGHTING CONTROLS

- a. Manufacturer: nLite or as approved by PSU Project Manager.
-  b. Design for daylight harvesting.
- c. For public space, install step dimming.



**PORTLAND STATE UNIVERSITY
DESIGN AND CONSTRUCTION STANDARDS**

- d. A system that is controlled at the individual fixture is preferred as opposed to a master lighting control panel.
- 5. EXTERIOR LIGHTING AND LIGHT POLES
 - a. Comply with City of Portland current standards. (See light post cut sheet below)
 - b. LED Lamps preferred.

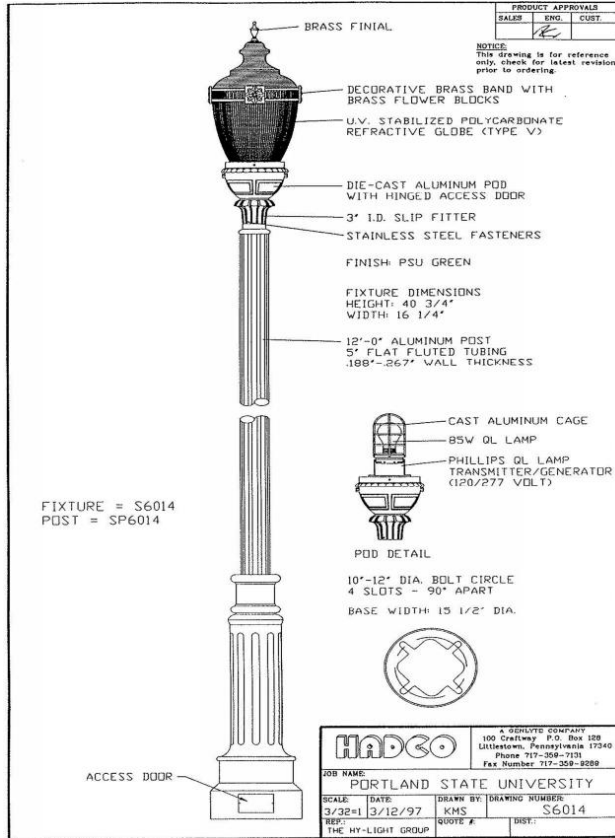

- 6. INSTALLATION
 - a. Exterior lighting fixtures shall be WET-LISTED watertight and shall have vandal-proof bases. For poles up to 15-20' high, hinged poles are preferred. All poles should meet, at a minimum, any seismic anchoring/bracing requirements. Exterior lighting fixtures shall have heavy-duty guards.
 - b. Fixture covers shall be UL-approved and regularly manufactured.
 - c. Select consistent fixtures and lamps for use throughout buildings. Minimize models, types and systems.
 - d. LED Fixtures to have electronic devices. Select items that are not going to become obsolete or difficult to obtain shortly after turnover to PSU.
 - e. Interior High Output Fixtures must have accessible ballasts.
 - f. When high light fixtures in auditoriums and gyms are used, consideration must be given to access, maintenance, and serviceability.
 - g. Accessibility to ballasts must be provided when using compact fluorescent fixtures.

PORTLAND STATE UNIVERSITY
DESIGN AND CONSTRUCTION STANDARDS

- h. Place power packs for switching in maintenance accessible-friendly locations. These items are best located directly above banks of light switches, or in electrical rooms when feasible.

END OF SECTION

PORTLAND STATE UNIVERSITY
DESIGN AND CONSTRUCTION STANDARDS

SECTION 27 – COMMUNICATIONS AND AUDIO VISUAL

A. PHONE AND DATA

1. DESCRIPTION

- a. Refer to Appendix 27.1 – Structured Cabling Standards - for all phone and data installations
- b. Telephone and Computer Network Cabling -- by PSU Office of Information Technology (OIT). Coordinate as required for complete installation. All cable and conduit to be concealed where possible.

B. AUDIO VISUAL

2. DESCRIPTION

- a. Refer to Appendix 27.2 – AV Standards for Audio Visual requirements.
- b. Protect existing AV Equipment and Cabling where applicable.
- c. New AV Equipment and Cabling -- by PSU OIT. Coordinate as required for complete installation. All cable and conduit to be concealed where possible. Refer to OIT Structured Cabling Standards (Appendix 27.1) & AV Standards (Appendix 27.2) for additional information and requirements.
- d. Provide electrical installations as required.

3. LOCATION / INSTALLATION

- a. Equipment locations are to be on a case-by-case basis. Consult with OIT prior to all installations or purchase of equipment. See Appendix 27.2 – AV Standards for Audio Visual requirements.

END OF SECTION

PORTLAND STATE UNIVERSITY
DESIGN AND CONSTRUCTION STANDARDS

SECTION 28 – **ELECTRONIC SAFETY AND SECURITY**

A. ACCESS CONTROL

- a. PSU currently has an exclusive contract for Lenel Security Management Software System for electronic access control in campus buildings. The server is maintained by PSU Office of Information Technology (OIT), it is maintained by FPM with the central station being monitored by Campus Public Safety Office staff. Installations, repairs or other work done on system must be performed by certified Lenel personnel and coordinated by CPC, FPM and CPSO Access Control team for Capital Projects & Construction design and construction projects. For further description, refer to Access Control standards (Appendix 28.1).
- b. Access control is required in all exterior doors (except ones that are exit only) and preferred on entry doors to office suites. Access control shall be considered and discussed with PSU Project Manager in all other spaces. PSU Project Manager will ensure that a meeting is held with CPSO to discuss installation locations.
- c. Card Access Doors
 - a. Provide/Install all transformer or other electrical devices and hardware required to support card access for locks and panic bars.
 - b. Strikes to be ANSI type 10-025, electric as required for card access.
 - c. Key card access control at all exterior entry points, including to roof, and at department suite entry and exit points. Retro-fit existing or provide at new doors for electric strike. Coordinate with existing PSU system, door hardware, or power opening device.

B. SECURITY CAMERAS

- a. All new building and major renovations should include security cameras at entrances and exits and in conjunction with any panic button installation. Additional thought should be given to installing security cameras in areas with public use, where cash is handled, and other potential high crime areas. Camera installation should include discussion with the Campus Public Safety Access Control Team.
- b. If cameras are installed panic buttons shall also be required. The installation of panic buttons shall be discussed on a case by case basis with PSU Project Manager. PSU Project Manager will ensure that a meeting is held with CPSO to discuss installation locations.

END OF SECTION

PORTLAND STATE UNIVERSITY
DESIGN AND CONSTRUCTION STANDARDS

SECTION 28 – **ELECTRONIC SAFETY AND SECURITY – FIRE ALARM SYSTEM**

ANALOG ADDRESSABLE FIRE ALARM SYSTEM

A. GENERAL

a. SCOPE

- i. The Silent Knight Farenhyt Series IFP-2000ECS or IFP-2000 24VDC analog addressable fire alarm system with IDP protocol addressable initiation devices and System Sensor two-wire synchronized notification devices is the Portland State University standard for Fire Alarm Systems.
- ii. The Silent Knight Select Farenhyt Engineered Systems Distributor shall furnish all labor, materials, appliances, cabling, tools, equipment, facilities, transportation, and services necessary for and incidental to the performance of all operations in connection with furnishing, delivery, and installation of all equipment, cabling, programming, configuration, testing, and training required by this Section, complete as indicated in the applicable Contract Drawings and/or specified herein.
- iii. This specification provides the requirements for the installation, programming, configuration, testing, and maintenance of a complete analog addressable fire alarm system. This system shall include, but shall not be limited to:
 1. Main Fire Alarm Control Panel (FACP)
 - a. Network Nodes (on network systems only)
 - i. Network Interface Module
 - ii. Fiber optic or copper network connection circuits
 - b. System cabinet
 - c. Power supply
 2. Digital Signaling Line Circuits (SLC)
 3. Notification Appliance Circuits (NAC)
 4. RS-485 Serial Communication Bus (S-bus)
 5. Annunciators both integral and remote
 6. Batteries
 7. Wiring
 8. Conduit
 9. Associated peripheral devices and modules
 10. Other relevant components and accessories required to furnish and install a complete and operational fully automatic, addressable reporting Life Safety System.
- iv. The fire alarm system shall be capable of providing, at a minimum, the following:
 1. Fire Alarm Control Panel (FACP)
 - a. Integral Digital Alarm Communications Transmitter (DACT).
 - b. Network Interface capability via copper and/or fiber optic network.
 2. Analog addressable initiation devices
 3. Analog addressable monitor and/or control modules
 4. Notification appliances
 - a. System Sensor.
 5. Notification Appliance Circuit (NAC) remote power supply
 - a. RPS-1000 Remote Power Supply shall provide the capability of housing the 5815XL SLC Expander for remote SLC generation.
 - b. Combination horn/strobe two-wire circuit.
 - c. Built-in synchronization capabilities

PORTLAND STATE UNIVERSITY
DESIGN AND CONSTRUCTION STANDARDS

- 6. Integral Voice Evacuation capability
 - 7. Firefighter Telephone capability
 - v. Any material and/or equipment necessary for the proper operation of the system, which is not specified or described herein, shall be deemed part of this Specification.
 - vi. Mini Monitor Modules are not allowed.
 - vii. The Analog Addressable Fire Alarm System specified herein shall be connected to a UL Listed Central Station Monitoring Company provided by Portland State University.
 - viii. Points lists with descriptions will be provided to Portland State University.
- b. **QUALIFICATIONS**
- i. **Equipment**
 - 1. The equipment installer should have at least three (3) years experience.
 - a. Equipment provided for this project shall be the product of Silent Knight Farenhyt by Honeywell.
 - 2. All equipment shall conform to currently adopted applicable codes and ordinances.
 - 3. All equipment shall bear the label of a Nationally Recognized Testing Laboratory (NRTL) such as Intertek Testing Services NA, Inc. (ITSNA - formerly ETL) or Underwriters Laboratories Inc. (UL) and be listed by their re-examination service.
 - ii. **System Supplier/Installer**
 - 1. The system shall be furnished and installed by a Silent Knight Select Farenhyt Engineered Systems Distributor who is trained and certified by the Manufacturer in the proper installation, programming, configuration, testing, service, and maintenance of the systems specified herein.
- c. **APPLICABLE CODES & STANDARDS**
- i. The Fire Alarm System shall comply with the currently adopted versions of the following:
 - 1. Building Standards Administrative Code, Part 1, Title 24,
 - 2. Oregon Fire Codes
 - 3. International Fire code with Oregon Amendments
 - ii. **NFPA Standards**
 - 1. The fire alarm system shall comply with the applicable provisions of the following current National Fire Protection Association (NFPA) standards:
 - a. NFPA 12 Carbon Dioxide Extinguishing Systems
 - b. NFPA 12A Halon 1301 Fire Extinguishing Systems
 - c. NFPA 13 Installation of Sprinkler Systems
 - d. NFPA 15 Water Spray Fixed Systems
 - e. NFPA 16 Deluge Foam-Water Sprinkler Systems
 - f. NFPA 16A Installation of Closed Head Foam-water Sprinkler Systems
 - g. NFPA 17 Dry Chemical Extinguishing Systems
 - h. NFPA 17A Wet Chemical Extinguishing Systems
 - i. NFPA 72, National Fire Alarm Code:
 - i. Central Station Fire Alarm Systems
 - ii. Local Fire Alarm Systems
 - iii. Auxiliary Fire Alarm Systems
 - iv. Remote Station Fire Alarm Systems
 - v. Proprietary Fire Alarm Systems
 - j. NFPA 70, National Electrical Code

PORTLAND STATE UNIVERSITY
DESIGN AND CONSTRUCTION STANDARDS

- k. NFPA 90A, Installation of Air Conditioning and Ventilating Systems
- l. NFPA 101, Life Safety Code - Safety to Life from Fire in Buildings and Structures
- m. NFPA 750 Water Mist Fire Protection Systems
- n. NFPA 2001 clean Agent fire Extinguishing Systems
- iii. ADA - Americans with Disabilities Act
- iv. U.L. Standards
 - i. The system shall comply with the applicable provisions of the following U.L. Standards and Classifications:
 - a. UL 38, Manually Activated Signaling Boxes
 - b. UL 268, Smoke Detectors for Fire Alarm Signaling Systems
 - c. UL 268A, Smoke Detectors for Duct Applications
 - d. UL 346, Water-flow indicators for Fire Protective Signaling Systems
 - e. UL 464, Audible Signal Appliances
 - f. UL 521, Heat Detectors for Fire Protective Signaling Systems
 - g. UL 864, Control Units for Fire Protective Signaling Systems
 - h. UL 1481 Power Supplies for Fire Alarm Systems
 - i. UL 1635, Standard for Digital Alarm Communicator System Units
 - j. UL 1638, Visual Signaling Appliances
 - k. UL 1971, Emergency Devices for the Hearing Impaired
 - l. UOJZ, Control Units, System
 - m. SYZV Control Units, Releasing Device
 - n. UOXX, Control Unit Accessories, System
 - o. SYSW Accessories, Releasing Device Service

B. PRODUCTS

a. SYSTEM REQUIREMENTS

i. Basic Performance and Capabilities

1. System shall be fully programmable and configurable on site to accommodate system expansions and facilitate changes in operation.
2. All software programs shall be stored in non-volatile programmable memory within the FACP.
 - a. Loss of primary and secondary power shall not erase the instructions stored in the memory.
 - b. System programming shall be password protected.
3. Alarm, supervisory, and trouble signals from analog addressable devices shall be encoded onto NFPA Class B signaling line circuits (SLC).
4. Initiation device circuits (IDC) shall be wired NFPA Class B.
5. Notification appliance circuits shall be wired NFPA Class B.
6. A single ground or open on any system SLC, IDC or NAC shall not cause a system malfunction, loss of operating power, or the ability to report an alarm.
7. Alarm signals arriving at the main FACP shall not be lost due to a power failure.
8. The system shall be provided with sufficient battery capacity to operate the entire system upon loss of 120 VAC power in a normal supervisory mode for a period of twenty four (24) hours with five (5) minutes of alarm indication at the end of this period.

PORTLAND STATE UNIVERSITY
DESIGN AND CONSTRUCTION STANDARDS

- a. Systems that include voice evacuation shall provide sufficient battery capacity for twenty-four (24) hours with fifteen (15) minutes of alarm in lieu of the five (5) noted above.
 9. The system shall automatically transfer to the standby batteries upon power failure. All battery charging and recharging operations shall be automatic. Batteries, once discharged, shall recharge at a rate to provide a minimum of 70% capacity in twelve (12) hours.
- ii. System Functional Operation
 1. The actuation of any approved alarm initiating device shall automatically initiate the following functions:
 - a. Alarm LED on the FACP shall flash.
 - b. Local audible piezo electronic signal in the FACP shall sound.
 - c. The alarm condition description, including the type of point and the location within the protected premises, shall be displayed on the LCD display at the FACP and any remote annunciator(s).
 - d. System shall transmit the condition to a UL Listed Central Station Monitoring Facility. History storage equipment shall log the information associated with the condition, including the time and date of the alarm occurrence.
 2. The actuation of any approved supervisory alarm initiating device shall automatically initiate the following functions:
 - a. Supervisory LED on the FACP shall flash.
 - b. Local audible piezo electronic signal in the FACP shall sound.
 - c. The supervisory condition description, including the type of point and the location within the protected premises, shall be displayed on the LCD display at the FACP and any remote annunciator(s).
 - d. History storage equipment shall log the information associated with the condition, including the time and date of the alarm occurrence.
 - e. System output programs configured via control-by-event (CBE) programming to be activated by the particular point in alarm shall be executed, and the associated system output (alarm notification appliances and relays) shall be activated on either local outputs or points located on other network nodes.
 3. Whenever a trouble condition is detected and reported the FACP shall automatically initiate the following functions:
 - a. Trouble LED on the FACP shall flash.
 - b. Local audible piezo electronic signal in the FACP shall sound.
 - c. The trouble condition description, including the type of point and the location within the protected premises, shall be displayed on the LCD display at the FACP and any remote annunciator(s).
 - d. System shall transmit the condition to a UL Listed Central Station Monitoring Facility.
 - e. History storage equipment shall log the information associated with the condition, including the time and date of the alarm occurrence.
 - f. System output programs configured via control-by-event (CBE) programming to be activated by the particular point in alarm shall be executed, and the associated system outputs (alarm

PORTLAND STATE UNIVERSITY
DESIGN AND CONSTRUCTION STANDARDS

notification appliances and relays) shall be activated on either local outputs or points located on other network nodes.

iii. Test Functions

1. A "Lamp Test" or "Indicator Test mode shall be a standard feature of the FACP and shall test all LED's and the LCD display on the main FACP and remote annunciators.
2. A "Walk Test" mode shall be a standard feature of the FACP.
 - a. The Walk Test feature shall function so that each alarm input tested shall operate the associated notification appliance for two seconds. The FACP will then automatically reset and confirm normal device operation.
 - b. The event memory shall contain the information on the point tested, the zone tripped, the zone restore, and the individual point's return to normal.
3. A "Fire Drill mode shall allow the manual testing of the Fire Alarm System notification circuits. The Fire Drill shall be capable of being initiated at the main annunciator, remote annunciators, and via a remote contact input.
4. "Bypass Mode" shall allow for any point or NAC circuit to be bypassed without affecting the operation of the total Fire Alarm System.

iv. Remote Monitoring Connection

1. The fire alarm system shall be connected via Digital Alarm Communicator Transmitter (DACT).
 - a. The fire alarm control panel shall provide an integral Digital Alarm Communicator Transmitter (DACT) for signaling to a UL Listed Central Station Monitoring Company.
 2. The fire alarm system shall transmit alarm, supervisory alarm, and trouble signals with the alarms having priority over the trouble signal.
- b. SYSTEM COMPONENTS – A listing of individual Silent Knight Farenhyt System Components will be provided upon request.
- c. Horns and strobes shall be White Ceiling mounted devices where viable.
- d. Smoke detectors shall be installed along and on path of egress. Per current enforceable code for corridor coverage.

C. EXECUTION

a. DIVISION OF WORK

- a. Equipment specific boxes provided by the system manufacturer shall be labeled for fire alarm by System Supplier/Installer
2. Elevator Recall
 - a. All relays for elevator recall will be in an accessible location. They shall not be mounted on the ceiling.
 - b. All recall programming shall be tested and documented.
 - c. Contractor is responsible for complete installation and final approved inspection per the elevator inspector.

b. INSTALLATION

- i. All work shall be completed in strict accordance with all applicable codes and ordinances, by a Silent Knight Select Farenhyt Engineered Systems Distributor.
 1. All cable/wire for the system specified herein shall be new, unless otherwise noted on plans.
 2. System cable/wire and equipment installation shall be in accordance with good engineering practices as established by the National Electrical

PORTLAND STATE UNIVERSITY
DESIGN AND CONSTRUCTION STANDARDS

Code. Wiring shall meet all applicable codes. All cable/wire shall test free from all grounds and shorts.

- a. All cable/wire shall be continuous between terminals with no splices.
3. All cable/wire shall be labeled at all points of termination. All labeling shall be based on the room numbers as provided by the District/Owner or his representative.
4. Underground cables
 - a. The cable/wire shall be intact with no cuts in the protective outer jacket.
5. PSU leased retail spaces
 - a. Each retail space should have a dedicated NAC circuit.
- c. **SYSTEM START-UP**
 - i. All start-up programming and system commissioning shall be performed by a manufacturer's trained and certified technician currently employed by the System Supplier/Installer.
- d. **SYSTEM VERIFICATION**
 - i. Subsequent to system start-up the system installer shall perform a 100% system pre-test to verify that the following features are functioning properly.
 1. All notification appliances
 2. All initiation devices
 3. All control modules
 4. All monitor modules
 5. Communication link to monitoring service
- e. **ACCEPTANCE TESTING**
 - i. The system installer shall, in the presence of the Inspector, perform 100% testing as noted in System Verification above.
- f. **IN SERVICE TRAINING**
 - i. The Contractor shall instruct personnel designated by the Owner in the proper use, basic care and maintenance of the system beyond the warranty period. Contractor shall provide in-service training with this system.
- g. **FACTORY TRAINING & CERTIFICATION**
 - i. When requested by Owner, provide Factory Training for a maximum of two District Technicians.
- h. **CONTRACT CLOSE-OUT DOCUMENTATION**
 - i. Contractor shall provide the following:
 1. One reproducible hard copy of project record drawings.
 2. Three hard copies of manufacturer's maintenance and operation manuals.
 3. One thumb drive in panel.
 4. Three copies of system warranty
- i. **WARRANTY**
 - i. The Contractor shall warrant the equipment and/or materials to be new and free from defects in material and workmanship, and will, within three (3) years from the date of final acceptance, repair or replace any equipment and/or materials found to be defective. This warranty shall not apply to any equipment or materials that have been subject to misuse, abuse, negligence or modification by owner or contractors other than the original installer that provided this warranty.

END OF SECTION

PORTLAND STATE UNIVERSITY
DESIGN AND CONSTRUCTION STANDARDS

SECTION 32 – **EXTERIOR IMPROVEMENTS**

A. IRRIGATION

1. The Contractor shall meet with the PSU Landscape Manager to review/evaluate final irrigation system prior to final acceptance and installation.
2. Provide and maintain temporary irrigation of species for two years. Refer to Section 32.B.1.a
3. Provide a manual shutoff valve to isolate the irrigation system from the water supply main.
4. Provide sprinkler heads and nozzle types of the same manufacturer and pressure rating within the same irrigation zone. Rainbird irrigation systems preferred.
5. Drip irrigation should be used in all planters and parking lot islands.
6. Color code Type U.F. control wiring as follows: ground/common wire – white; lead-in signal wire – red; spare signal wire – orange; moisture sensor wire – green; master valve wire – yellow; master valve dedicated common wire – white; future expansion signal spares – black; future expansion common – white.
7. Provide quick coupler valves (e.g. Buckner QB44RC-10) every 100 feet or less. These quick coupler valves are used to hand water landscaped areas. Locate quick coupler valves to limit water hoses crossing walkways and roads.
8. Irrigation Pipe shall be PVC Schedule 40.
9. All new and substantially modified irrigation systems are to be provided with a Rain Bird ESP-LXME, or approved equal, irrigation controller. Controller shall be equipped with Ethernet connection capability, IQNCCEN Rain Bird IQ or approved equal. All power wiring and communication wiring shall be installed in separate conduits and per applicable building codes.
10. All new spray heads shall be Rain Bird 1800-SAM-PRS or approved equal.

B. PLANTING

1. GENERAL

- a. Selection of plants shall require plant varieties that are drought-tolerant and require minimum to no irrigation beyond first years of establishment. Irrigation systems should be limited to what is operationally and cost-effective during maturing years. It is preferred that irrigation not be completely disconnected.
- b. Prefer selection of native species. Consider maintainable, adaptable, low-maintenance, and non-invasive species

2. TREES

-  a. The use of native, not cul-var, species is encouraged.
- b. The following species are forbidden in designs: poplars, female ginkgo, pin oaks, and locusts. Refer to City of Portland Parks and Recreation's Urban Forestry Division's list of recommended species and The Campus Tree Care Plan – Appendix 32.1. Unless included in contained and designated areas for food production and wild life habitat, trees that produce berries, fruits or nuts shall be prohibited.
- c. Aspens are prohibited in bioswales.
- d. Tree planting to occur only during October through December, and March through May.
- e. Pruning of newly planted trees, except limbs that are dead or broken, is prohibited.

PORTLAND STATE UNIVERSITY
DESIGN AND CONSTRUCTION STANDARDS

- f. Species and placement of trees by approval of PSU's Landscape Manager in accordance with the insulation procedures that can be found in Appendix 32.1 The Campus Tree Care Plan.
- g. All trees to be planted by approved Landscaping Contractor or PSU Landscape Staff.

3. TURF AND GRASSES

-  a. The use of drought-tolerant species is preferred
- b. Areas to be grassed shall be seeded. Use of sod is discouraged. All grass seed used shall be 'certified'.
- c. Hydro seeding is the preferred method of seeding large areas.
- d. Select grass blend to accommodate formal or informal pedestrian traffic patterns.
 - i. Sun locations: 3-way Perennial Ryegrass blend
 - ii. Shade locations: 30% Perennial Rye, 60% Creeping Red Fescue
- e. Seeding to be done late summer or early fall.
- f. Newly seeded areas shall be watered for a period of two to three weeks after application of seeds.

4. PANTING BEDS AND PLANTS



- a. Preferred designs shall include raised planting beds with a mix of medium-sized bushes and/or shrubs, colorful perennials for interest and diversity, and grasses not requiring mowing (e.g. bunchgrasses).
- b. Plants must be grouped in beds with plants of similar needs for sunshine/shade, water or fertilization, soil type, and PH.
- c. Kinnikinnick ground cover is prohibited.
- d. Decorative rock is not to be used in planting beds.
- e. All landscape designs to be reviewed by PSU Landscaping.

C. LANDSCAPING MAINTENANCE

Provide landscape maintenance for two years.

D. PAVING

1. DESCRIPTION

- a. Large areas of exterior concrete flatwork for roads and sidewalks increase surface runoff of rainwater into the City of Portland's storm water drainage system and prevent natural percolation into the subsurface. Designs of large areas of flatwork should include collecting or routing of this runoff into flowerbeds, bioswales, and other planted areas.
-  b. The use of recycled aggregate at the highest percent possible is encouraged where appropriate and structurally allowed. Exposed aggregate sidewalks are discouraged except to match existing, e.g. the Park Blocks and Montgomery Greenway.
- c. When selecting pavers, provide products that have adequate drainage systems.
-  d. Where applicable, the use of permeable pavers is encouraged.

END OF SECTION

PORTLAND STATE UNIVERSITY
DESIGN AND CONSTRUCTION STANDARDS

SECTION 33 - **PARKING**

A. GENERAL

1. Green Garage Certification
2. Following all City Requirements
3. PSU Climate Action Plan

B. EQUIPMENT

1. PRODUCTS / LOCATION

- a. Curb Stops (Parking Bumpers)
Manufacturer: Traffic Safety Supply Company's, model: Recycled Rubber Parking Block or as approved by PSU Project Manager and PSU Transportation and Parking Services. Product #: 3S-WS48 from Street Smart Solutions. Lag6 - screws and washer/shields
- b. Speed Bumps
Manufacturer: Traffic Safety Supply Company's, model: 100% Recycled Plastic Speed bump or as approved by PSU Project Manager and PSU Transportation and Parking Services.
- c. Bollards and Posts
 - a. 48" magnetic posts, black with white reflective stripping located at UCB Garage. Manufacturer: Parking Zone, model: "Gorilla Posts" or as approved by PSU Project Manager and PSU Transportation and Parking Services. Product #: GPMAGBOLLARD48BLKWV2
 - b. Flexible Posts, black with white reflective striping located at 4th Avenue Garage and Parking Structure 1 Manufacturer: Street Smart Solutions, model: "Self-erecting Flexible Posts 3s-K71" or as approved by PSU Project Manager and PSU Transportation and Parking Services. Product #'s: 3S-K71-B-W, posts; 3S-K71-BTC, black top caps; 3S-K71-AB, anchor bolt sleeves.
 - c. Safe-hit posts, white with 2 white reflective bands (round). Manufacturer: Traffic Safety Supply Co., INC. Product # 11613910

2. Signage

- a. "Standard Reserved Space" sign ordered from Sign Shop

3. Traffic Control markings

4. Paint

- a. Miller Paint - Premium Eggshell – 38864
- b. Miller Paint - T/M Green Premium Satin Neutral Base – 44884

5. Bird Spikes

- a. Manufacturer: Bird-B-Gone. 5" Wide Stainless Steel Bird Spike, Product #: BBG2001-5

C. TECH

1. Garage Door - Make/model: Various, Support: Metro Overhead
2. Gate Arms - Make/Model: Various, Support: Metro Overhead
3. Fencing - Make/Model: , Support: Pacific Fencing
4. Access, Camera, Panic Buttons- Make/Model: Various, Support: Reece

PORTLAND STATE UNIVERSITY
DESIGN AND CONSTRUCTION STANDARDS

5. Lighting
 - a. Simply LEDs - 50W CEILING FIXTURE, GRANITE, Acrylic Diffuser, 5000K, 70+CRI, Bridgelux BXRA LEDs - Product #CLG-50-C-AP
6. Awnings - Make/Model: Custom, Support: Pike Awnings
7. Pull Station Location
 - a. No current pull stations, fire extinguishers installed on each level
8. Ventilation
9. Co2 Monitors
10. Surface Coatings
11. Pay stations - Make/model: T2 Luke 2, Support:T2 systems
12. Vehicle Count Controller, Make/Model: T2 AutoCount, Support: Metro Overhead
13. Radio Repeater - Contact Event Rental Communication
14. Bird Spikes: Bird-B-Gone Stainless Steel Bird Spike, product # BBG2001-5

D. BIKE PARKING

1. Long-term bike parking facilities
 - a. Site Furnishing
 - b. Access control
 - c. ID Card access control system is mandatory for all locations and must be compatible with Lenel system and meet PSU standards for access control. This includes door hardware, locking mechanism, access panel and all associated materials for connectivity.
 - d. Security cameras will be installed to monitor and record all use of entrance door(s) at minimum. Additional security cameras to monitor interior of bike facility are optional, depending on design and layout of facility
 - e. Orientation of racks will be determined to maximize space while maintaining access. Space design will be approved by TAPS before installation.
2. 48" door for all entrances and exits
3. Bike Racks
 - a. Huntco Staple (horizontal parking)
 - b. Dero Decker (two-tiered, articulated parking system, horizontal)
 - c. Dero Ultra Space Saver (vertical rack system)
 - d. Cargo Bike Staple (customized short version of Hunto staple)
4. Storage for bicycle locks shall be provided (simple bar/pipe mounted to wall allowing users to securely store their lock)
5. Signage
 - a. Instructions for rack use will be posted
 - b. Cargo bike spaces will be marked and signed for cargo bike use only

PORTLAND STATE UNIVERSITY
DESIGN AND CONSTRUCTION STANDARDS

- c. Bike Garage Design
- 6. Space allocated to secure bicycle parking in new or remodeled buildings shall be based on target bicycle mode share identified in the PSU Climate Action Plan
- 7. Preferred design allows for people with bicycles to enter the facility separate from vehicle traffic if auto parking is present. Streetside or at-grade entry is preferred.

E. SHORT-TERM BIKE PARKING FACILITIES

- 1. Site Furnishing
 - a. Huntco Staple
- 2. Preferred model is Staple Corral w/3-4 racks per unit
- 3. If Corral is not possible individual Staple units will be used
- 4. Site location
 - a. Short-term bicycle parking should be located within 50 feet of the building entry
 - b. Use of the building footprint should be prioritized over use of the furnishing zone in the public right of way
 - c. Tamper resistant hardware and/or secure access is required for facility.

F. KIOSKS

- 1. Make/Models vary. Any new kiosks will need to be ADA compliant.
 - a. Air Conditioning in Kiosk. Make/Models vary by kiosk. They should be Energy Star compliant.

END OF SECTION

Appendix 01.5
Custodial and Storage Closet

PORTLAND STATE UNIVERSITY
DESIGN AND CONSTRUCTION STANDARDS

APPENDIX 01.5 – CUSTODIAL AND STORAGE CLOSETS

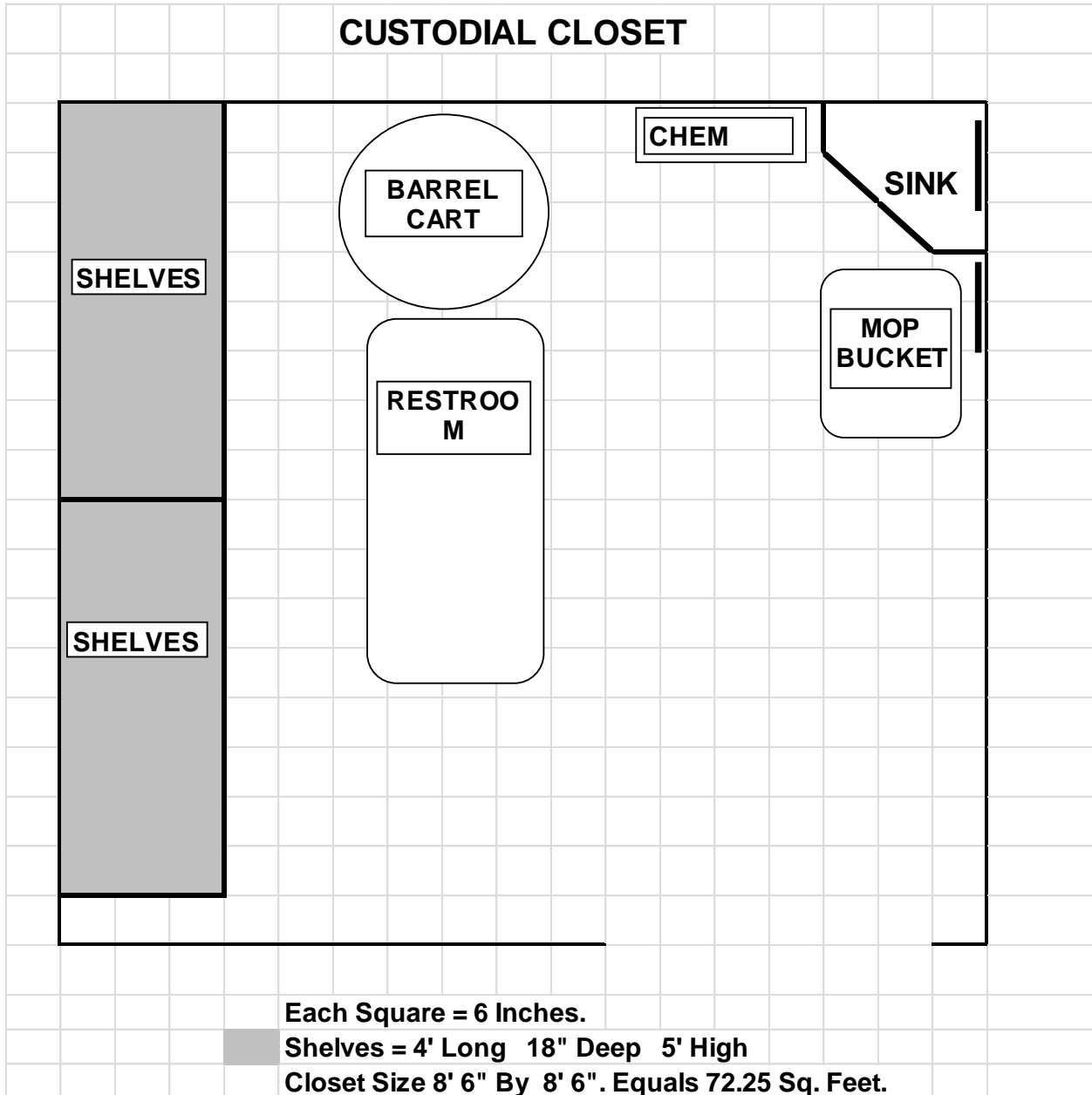

PORTLAND STATE UNIVERSITY
DESIGN AND CONSTRUCTION STANDARDS

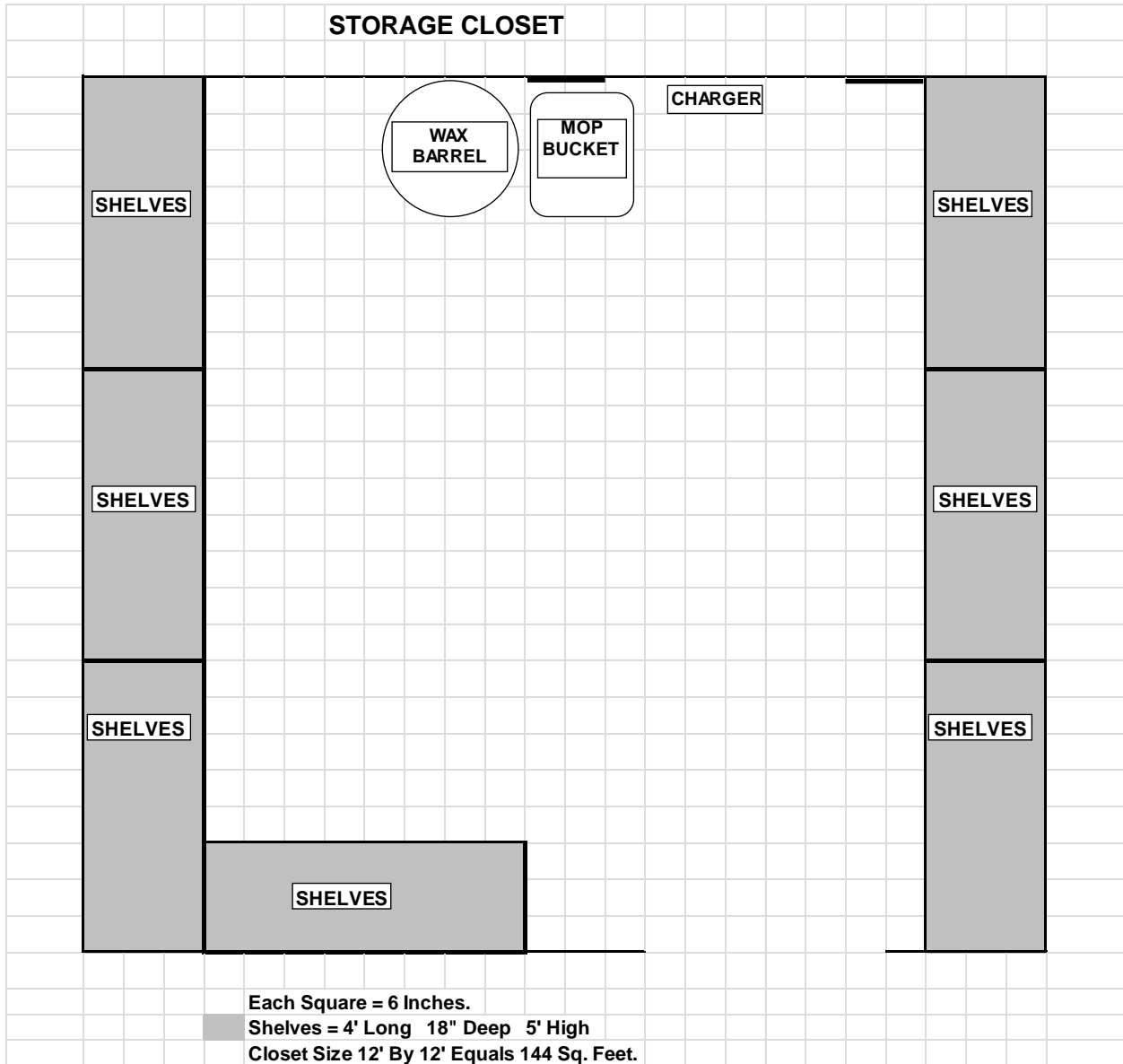

Appendix 01.6
Restroom Preferences

PORTLAND STATE UNIVERSITY
DESIGN AND CONSTRUCTION STANDARDS

APPENDIX 01.6 – **RESTROOM PREFERENCES**

Restroom Flooring – Avoid using ceramic tile. Preferred flooring is a seamless floor and cove base.
Example: Epoxy Quartz Seamless Floor.

Restroom Partitions - Recycled plastic is a suitable material for toilet partitions due to the non-structural requirements of the product and the durability and clean-ability of the material. These products use recycled HDPE post-consumer plastic. Depending on the product, the recycled content can vary from 30% to 75%.

All restroom partitions must be made from high recycled content plastic, or reclaimed materials.

High-Recycled Content Plastic Compartment Resources:

- **Santana Plastic Products**
1300 Meylert Ave.

Scranton, PA 18509

800/368-5002

- **Comtec Industries, Inc.**
801 Corey

Moosic, PA 18507

800/445-5148

- **Inteq Corp.**
33010 Lakeland Blvd.

Eastlake, OH 44095

440/953-0550

Water Heaters

All water heater thermostats must be set no higher than 120 degrees. All water heaters shall have at least 1.5 inches of foam insulation. Contractors shall select a water heater with the highest energy factor

PORTLAND STATE UNIVERSITY
DESIGN AND CONSTRUCTION STANDARDS

(EF) and annual fuel utilization efficiency (AFUE) rating. EF is based on recovery efficiency, standby losses, and cycling losses. Electric-resistance water heaters have an EF ranging from 0.7 to 0.95; gas water heaters from 0.5 to 0.6, with a few high-efficiency models at around 0.8; oil water heaters from 0.7 to 0.85; and heat-pump water heaters from 1.5 to 2.0. Product literature from the manufacturers usually give the appliance's EF rating. If it does not, literature can be obtained by contacting an appliance manufacturer association. AFUE ratings are shown on product EnergyGuide labels. The higher the EF and AFUE ratings, the more efficient the water heater.

All water heaters must be compared on the basis of EF and AFUE ratings. All other things being equal, heat pump and electric water heaters are preferred and the product with the highest EF and AFUE is recommended.

Water Heater Resources:

- Top-rated gas and oil water heaters: www.aceee.org/consumerguide/topwater.htm
- www.energystar.gov

Water Saving Devices

Devices that lower the quantity of water flow can reduce the operating costs of a building. The U.S. Energy Policy Act of 1992 established water conservation standards for water closets, showerheads, faucets and other uses to save water consumption in the United States. These standards can be met and even exceeded by installing sensors and flow restrictors on water fixtures.

Contractors are required to employ strategies that in aggregate use 20% less water than the water use baseline calculated for the building (not including irrigation) beyond meeting the Energy Policy Act of 1992 fixture performance requirements.

Energy Policy Act of 1992 Flow Requirement	
Water Closets/Dual Flush (GPF)	1.6/1.28
Urinals (GPF)	1.0
Showerheads (GPM)	2.0
Faucets (GPM)	1.0
Replacement Aerators (GPM)	0.5

PORTLAND STATE UNIVERSITY
DESIGN AND CONSTRUCTION STANDARDS

Additional interior water saving methods include installing dry fixtures such as composting toilets and waterless urinals. Indoor water efficiency products that meet these requirements are readily available locally.

Faucets – All faucets shall be Chicago. PSU maintains a storage of spare parts manufactured by Chicago.

Water Saving Product Resources:

- How to Buy a Water-Saving Faucet/Showerhead/Toilet: www.eren.doe.gov
- US Department of Energy Federal Emergency Management Program

DIVISION 10 - SPECIALTIES

Section 10810 - Toilet Accessories

Introduction

This section addresses the type of accessories which are to be provided or anticipated for all new and remodeled restrooms.

Below are the requirements for toilets which will be serviced and maintained by Facilities Management.

Part 1 – General:

- Provide at least one paper towel dispenser for every three sinks and install at HC accessible height.
- All dispensing units shall be surface mounted. Recessed elements are to be avoided. Stud walls should receive appropriate blocking to accommodate surface mount attachment.
- For new projects, FM Custodial Services will provide hand soap and toilet tissue dispensers for installation by the contractor. Paper towel dispensers are to be provided and installed by the contractor.
- Trash receptacles are to be located or at least anticipated in every restroom.
- Provide an Accessories Schedule in the specifications or on the drawings listing each room and the quantity of each type of accessory required *as well as who provides what elements and who installs.*
- Consultant should anticipate and prescribe locations of owner furnished elements so as to insure that conflicts with contract work do not exist.
- All lavatories or groups of lavatories shall be installed within a counter or a shelf installed adjacent to the lavatory so belongings can be placed on them while lavatory is in use.

Part 2 – Products:

- Paper towel dispensers shall be surface mount, **Kimberly Clark # KC-09765 (Lever) or KC-09990 (Hands Free) or authorized equal.**
- Soap dispensers are provided by Custodial Services *via their soap vendor* and are surface mounted **GoJo style dispensers** . Avoid attaching to mirror.

PORTLAND STATE UNIVERSITY
DESIGN AND CONSTRUCTION STANDARDS

- Toilet tissue dispensers shall be surface mount, **Kimberly Clark # KC-09507 or authorized equal.**
- Seat Cover Dispensers shall be surface mounted **Bobrick B-221** or authorized equal.
- Toilet/Urinal Partitions – Preferred is **Brobrick “Sierra Series” Solid Color Reinforced Composite.** If limited color selection is an issue then **Brobrick “Duraline Series” Solid Phenolic partitions can be used.** Other manufacturers can be used if partitions are equal to or better than Brobrick.
- Diaper Changing Stations shall be surface mount, **Koala Bear Kare** or authorized equal.
- Sanitary napkin disposal units shall be surface mounted and constructed of stainless steel. **Bobrick B-270** or authorized equal.
- Waste receptacles will be provided by Custodial Services as part of FFE and will be free standing units.
- Grab bars shall be stainless steel, 18 gauge minimum wall thickness, 1.5" minimum outside diameter with concealed mounting devices. Install to provide 1.5" clearance between wall and inside face of handrail.
- Mirrors shall be 1/4" glass with stainless steel frame and concealed fasteners. Locate and size mirror to provide adequate free wall space for soap dispenser.

Part 3 – Execution:

- Provide stud wall backing for all surface mounted accessories.
- Protect all toilet accessories from damage during the course of construction.
- Clean all surfaces in strict accordance with manufacturer's recommendations after removing temporary labels and protective coatings.
- Mount paper towel dispensers with lever at 48" A.F.F. for ADA accessibility.
- Layout all accessories to ensure that surface mount elements do not restrict access to sinks.

Appendix 01.10
Construction Safety Checklist

Construction Safety Checklist (Contact CPC for latest Checklist)

(Revised on October 2, 2017)

Room Number/s:		Date:	Sign-offs				Corrective Action By	Comments
Construction Phase:		FPM	Contractor	CPC	EHS	Design Team Rep		
General								
G.1	Hazardous materials in this area have been abated or have been identified for future abatement.							
G.2	Hazardous conditions in this areas resulting from demolition and construction have either been remedied or identified for future remedial action.							
G.3	Prior to beginning work and upon completion of work, an inspection of the building's existing conditions occurred. These inspections were to ensure there are no unknown safety concerns that either existed or may have been created due to the recent project demolition or construction. Examples may include protrusions, trip hazards, improperly supported ducts, piping, wires, etc.							
G.4	All tools, equipment, debris, and un-used construction materials have been removed.							
Electrical (Also includes low voltage and controls)								
E.1	Visible conductors have been terminated, secured properly, removed, and/or identified as abandoned.							
E.2	Equipment (boxes, enclosures, panels, etc.) have been secured and properly anchored and/or identified for future correction.							
E.3	All wiring and conductors at equipment have been terminated properly and/or identified for future correction.							
E.4	Devices (light switches, receptacles, OCPD's, etc) and raceways have been secured, properly anchored, are in the appropriate location, and/or identified for future correction.							
E.5	All junction box covers, panel covers, and LB covers placements have been verified, fully secured, and/or identified for future correction.							
E.6	All over-current protection devices that are remaining in place without load have been opened and/or identified for future correction.							
E.7	All schedules are typed capturing all new loads, existing loads and within the MDP, SDP, and or PB.							
Plumbing/Mechanical								
M.1	Piping, ductwork, and equipment have been properly secured and/or identified for future correction.							
M.2	Valves, dampers, control panels, maintenance items, etc. have been checked for accessibility.							
M.3	All abandoned pipes have been capped, secured, and/or labeled as abandoned.							
M.4	All water or air leaks have been identified.							
Architectural/Structural								
A.1	All ceilings have been secured to building structure and/or identified for future correction.							
A.2	It has been confirmed that nothing is resting directly on drop ceilings and that any items resting directly on hard-lid ceilings do not exceed the capacity.							
A.3	All glass has been secured properly, whether exterior façade glass or interior glass partitions.							
A.4	All interior fixtures, building specialties and furniture have been properly secured.							
A.5	All unused drop ceiling connections (support wires, seismic wires, grid, etc.)							

	have been removed.							
A.6	All protruding objects (nails, screws, bolts, studs, etc.) whether in the floor, walls, or ceilings have been removed or identified for future correction.							
* Note: After Photos to be provided as necessary								

DRAFT

Completion of Construction Safety Sign Off

This Section to be Completed by PSU Project Manager Prior to Construction

Project: _____ Construction Date: _____

Contractor: _____ PSU Project Manager: _____

Room Number/s: _____

Project Scope: _____

Phases of Construction at which Construction Safety Sign Off is Required:

Return Signed Certification & Checklist To: Capital Projects & Construction Attn: PSU Project Manager

University Services Building
617 SW Montgomery Suite 302
Portland, OR 97201

In an effort to take every opportunity possible to improve Campus safety and to eliminate as much confusion as possible when planning future work, PSU Capital Projects & Construction (CPC) has instituted a procedure to review work site conditions upon completion of work milestones in a given area. This process will include representatives of CPC, as well as PSU Facilities & Property Management (FPM), PSU Environmental Health & Safety (EH&S), & the Contractor.

One of our goals is to leave areas in as safe a manner as possible. Therefore, the procedure includes a review to insure that tools, material, equipment, debris, etc. have been removed and that remaining installed items have been left in a safe manner. This will insure that the work area will be as safe as possible for the occupants of a space.

The other main objective is to make a last evaluation regarding adding scope to a project to eliminate unnecessary congestion in our work areas by removing or, at least, mapping and/or labeling obsolete items. This will help reduce confusion when we return to that work area for future maintenance or projects.

By signing below the individuals attest that the items on the below checklist have been inspected to the best of their abilities, accessibility and knowledge.

Approved by Contractor _____
Approved by Design Team Representative _____
Approved by PSU Project Manager _____
Approved by CPC Director _____

Appendix 01.11
Healthier Buildings Guide



Healthier Buildings

A public procurement guide to safer products for new construction and existing buildings

Version 1: October 2015

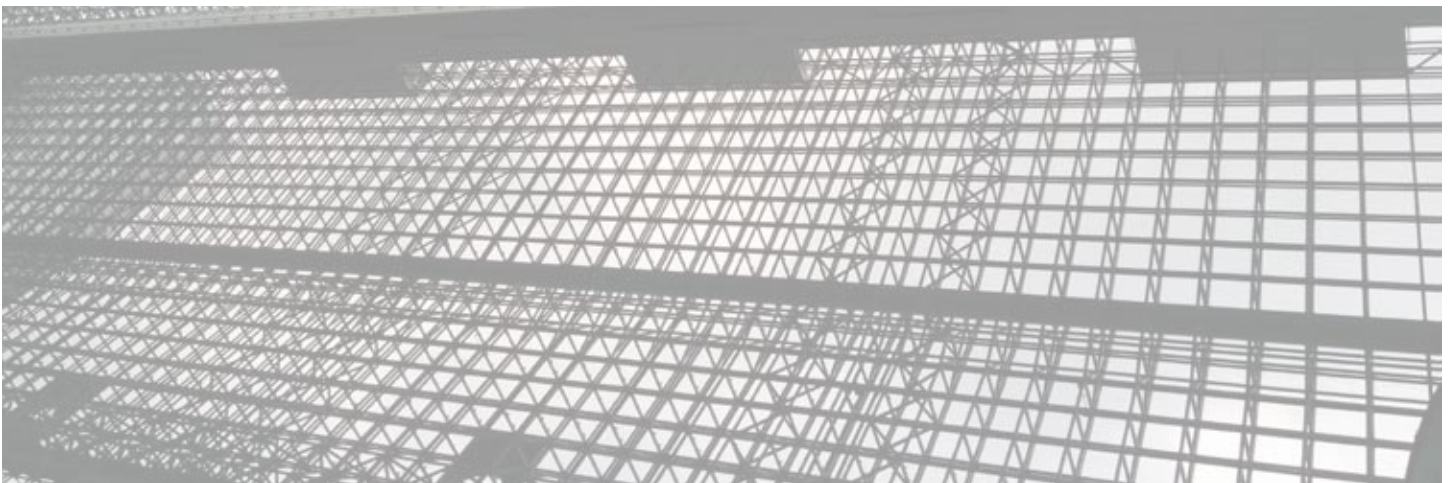

Acknowledgements

Oregon Environmental Council would like to acknowledge the important contributions of time and expertise made by the following organizations. Their input and feedback on the contents of this guide have added significant value and are appreciated.



Contents

About this guide	1
Responsible, innovative procurement	
The science supports action	2
Chronic disease, hazardous chemicals	
Common chemicals in building products	3
What chemicals, where they're used, how they impact health	
Sample language	6
Sample language for Contracts, Technical Design Standards, ITBs, RFPs, Design Guidelines	
Product vendor outreach	15
Sample vendor outreach letters for safer products	
Relevant resources	18
Links to useful tools, guidance, and organizations	
References	20

Founded in 1968, Oregon Environmental Council (OEC) is a statewide nonprofit dedicated to advancing innovative, collaborative solutions to Oregon's environmental challenges for today and future generations.

For more information:

Colin Price
Director of Market Innovation

503-222-1963 x117
colinp@oeconline.org

www.oeconline.org

About this guide

What does “healthier buildings” mean?

When we say healthier buildings, we’re talking about using materials and products to construct, rehabilitate, remodel, or maintain buildings that contain safer alternatives to toxic chemicals. While there are other factors, like ventilation, natural light, and other design features that contribute to occupant health, this guide is focused on how to ensure that your projects use safer products. Safer products don’t contain toxic chemicals, or contain fewer toxic chemicals that are inherently less hazardous.

Considering human health and well-being in building projects is responsible and innovative

Public procurement and project management professionals are dedicated practitioners who hold important decision-making power. Leading public sector organizations, in collaboration with contractors and their supply chains, are using information about chemical ingredients and safer alternatives in innovative ways to inform the design, engineering, construction, and operation and maintenance of buildings.

A guide to empower procurement professionals

Together, state and local governments across the U.S. spend about \$1.5 trillion annually on goods, supplies, equipment, services, and construction.¹ That means that your organization has the power to protect the public, employees, and the environment while creating a positive influence in the marketplace. Even if your budget or scope is relatively small, when you embed healthy building elements into standards, solicitations, and contracts, you’re part of a larger movement of organizations and governments across the country and around the world. Together, we’re able to drive demand for safer, healthier building products.

Every building can use safer, healthier building products

Even if your project isn’t pursuing a green or sustainable building certification, it can still be a healthy building. Healthy buildings help minimize organizational risk, and represent a responsible use of public funds. Hiring building professionals like architects, engineers, and contractors that help provide reasonable due diligence to protect human health makes sense for any project.

A note about costs

Many people still consider “green” building features or safer building products to carry an extra cost for projects. While a cost comparison specific to safer building products was beyond the scope of this guide and does not appear to currently exist for reference, experience by a wide variety of public and private sector organizations reveals that many safer products that do not contain toxic chemicals are cost competitive with traditional versions. For more information about costs, see the Relevant Resources section on page 18 of this guide.

The science supports action

Chronic diseases are among the most common, costly, and preventable of all health problems in the U.S.

- Seven out of 10 deaths among Americans each year are from chronic diseases
- Heart disease, cancer and stroke account for more than 50% of all deaths each year²
- One in 11 American kids have asthma³

Strong scientific evidence links toxic chemicals to some chronic diseases

There are multiple factors that can cause chronic diseases in people, including genetics and lifestyle choices like nutrition and physical activity. Environmental factors, including exposure to toxic chemicals also play a role in chronic diseases in people, including children.³ For example, over 200 chemicals are known, or reasonable anticipated to be human carcinogens, including diesel particulate matter, formaldehyde, vinyl chloride, and styrene.⁵

Toxic chemicals linked to chronic diseases and other health impacts are commonly found in building materials and products

Chemicals scientifically linked to chronic diseases like cancer, asthma, and obesity are used in a wide variety of materials and products used to construct and maintain our workplaces, homes, schools, and other buildings. Flooring, furniture, paints, and sealants are some of the materials that frequently contain chemicals of concern for human health and the environment.

Hazardous chemicals commonly found in building materials and products are also found in our bodies

National health surveys conducted by the Centers for Disease Control and Prevention have found more than 148 synthetic chemicals present in the blood and urine of most Americans.⁶

Chronic diseases that result from environmental exposures to these hazardous chemicals are preventable

We spend up to 90% of our time indoors.⁷ This makes healthier indoor environments and good indoor air quality critical in preventing unnecessary exposures to hazardous chemicals.

Prevention of these diseases can result in significant cost savings and improve our quality of life

Chronic diseases like cancer, asthma, and diabetes impact our physical, mental, and emotional well being over long periods of time. Managing chronic diseases is costly for individuals and families, as well as our society. Medical expenses and the associated losses in productivity that result from missing work from chronic diseases cost an estimated \$13 billion in Oregon in 2010.⁸

Common chemicals in building products

We consider materials and products used in and around our buildings to be an important design consideration because they frequently contain hazardous chemicals. Since we work, play, learn, and live so much of our lives indoors, the potential for continuous and prolonged exposure to hazardous chemicals is significant. The following is some basic information about where hazardous chemicals are found in some building products, how we're exposed, and how our health can be impacted. In many cases, safer alternatives to these hazardous chemicals exist or are being developed and tested.

Flame Retardants (Halogenated and Organophosphate)



Halogenated flame retardants (HFRs) are a class of chemicals that use halogens including bromine and chlorine. Organophosphate flame retardants are a class of chemicals that use phosphorous.

Products that commonly contain flame retardants include foam building insulation, polyurethane foam, wire and cable, and electronics. We're commonly exposed to flame retardants through dust in our buildings.^{9,10}

These chemicals have been shown to disrupt thyroid and estrogen hormones, which are linked to reproductive and developmental health effects including reduced sperm count in males, changes in ovarian cell structure in females, and abnormal brain development in children.^{11,12} Many HFRs are also persistent in the environment and bioaccumulative, building up in children's bodies through breast milk and dust inhalation.^{14,15,16} Organophosphate flame retardants are also linked to impacts on fish and other aquatic organisms.¹⁷

Perfluorochemicals (PFCs)

PFCs are commonly found in stain and non-stick treatments, including Scotchguard®, Teflon®, and Stainmaster® on furniture, carpet, and other office products with fabric.¹⁷ Common PFCs include perfluorooctanoic acid (PFOA) and perfluoroactane sulfonate (PFOS).

These chemicals do not break down in the environment and are found in indoor dust as well as human breast milk, where they are passed on to infants.^{18,19} PFCs can cause reproductive and developmental health effects in children including impaired behavior, learning, and memory as they become adults.²⁰

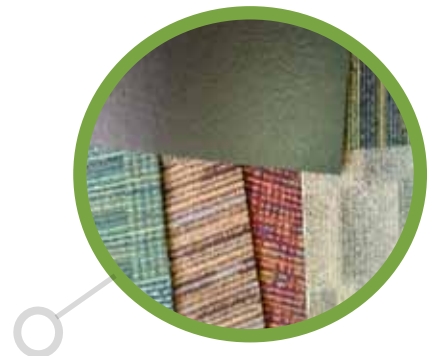

Chlorinated Compounds

The manufacture and disposal (combustion) of chlorinated compounds like polyvinyl chloride (PVC) produces a variety of chemicals including dioxins, vinyl chloride, polychlorinated biphenyls (PCBs) and more.²¹ Vinyl chloride is a potent carcinogen, known to affect the liver, brain, and lungs at low concentrations.²² Dioxins are some of the most toxic chemicals known and are created when chlorinated plastics burn. They do not break down in the environment, accumulating in our bodies where they can cause cancer.²³

Chlorinated compounds including PVC, chlorinated polyethylene, and polychloroprene are ubiquitous plastics, found in pipes, door and window frames, resilient flooring, carpet backing, furniture, membranes, and many other products. These plastics are frequently made with other toxic chemicals like phthalates and metals.²⁴



Volatile Organic Compounds (VOCs)



VOCs are a class of chemicals including formaldehyde, toluene, xylenes, and methylene chloride that are commonly found in building products.²⁵ VOCs are emitted as gases from solids and liquids and may concentrate in indoor air, where levels can be much higher (up to 10 times) than outdoors.²⁶

They are commonly found in paints, adhesives, cleaning supplies, composite wood products, and furniture. Concentrations of VOCs in new buildings have been shown to be higher than in established buildings, often at levels linked to increased cancer risk in humans.²⁷ VOCs can also cause headaches and damage the liver, kidneys, and central nervous system.²⁹

Phthalates

Phthalates are a class of chemicals that are used in a wide variety of products as a plastic additive.³⁴ Phthalates, and specifically Di(2-ethylhexyl) phthalate (DEHP) is used in PVC building materials.

Phthalates are a concern given their potential reproductive and developmental health effects on children, particularly to children exposed in the womb.^{35, 36} Exposure to phthalates, and specifically DEHP has been linked to cancer, skeletal malformations, developmental delays, and adverse effects on the male and female reproductive tract.^{37, 38}



Heavy Metals

Metals commonly found in building materials include lead, cadmium, and mercury. Mercury is found in synthetic gypsum board (also known as drywall or wallboard) and can leach into water from unlined landfills, where it comprises about 15% of construction and demolition debris.³⁹ ⁴⁰ Mercury is particularly toxic to children, where exposure results in a loss of intelligence and impaired learning, attention and memory.^{41, 42} In adults, low levels of mercury exposure over time are linked to diseases similar in nature to Alzheimer's.⁴³

Sample language

The following section includes sample language for a variety of building construction, renovation, and operations & maintenance-related documents including procurements, contracts, and design standards.

The sample language included in this section can be added to documents verbatim, or modified to suit the need of individual organizations and projects.

For some sample language sections, like for the Standard Professional Services Contract, sample language can be added to sections or subsections of existing documents that bear the same or similar title as denoted by “**(or similar section)**”. It’s up to the document developer to determine which section or subsection most closely align with the sample language provided.

In some cases, like the sample language provided for Invitations to Bid, you will need to customize it by filling in **[bracketed]** sections.

Sample Language - Standard Professional Services Contract

Standard Professional Services Contracts are commonly used by organizations when hiring architectural, engineering, and other building construction and renovation-related service providers. The following sample language is designed to be added to existing sections and subsections.

PROJECT PHILOSOPHY (or similar section)

In pursuing these goals, Consultant, with Owner's assistance, shall:

Reduce the number of toxic chemicals used in specified products on the Project, like those identified in the State of California's Proposition 65 List, the Living Building Challenge Red List, and other relevant lists of chemicals of high concern.

BASIC SERVICES - SCHEMATIC DESIGN SERVICES (or similar section)

MATERIALS RESEARCH/SPECIFICATIONS Services (or similar subsection).

(Note: Add to existing section language) Consultant shall include: less toxic materials specifications or materials lists reviewed by third-party certification programs; safer products which are already commercially available to the greatest extent possible; safer options that also limit premium costs and overall lifecycle costs.

BASIC SERVICES - DESIGN DEVELOPMENT SERVICES (or similar section)

MATERIALS RESEARCH/SPECIFICATIONS Services (or similar subsection)

(Note: Add to existing section language) Consultant shall conduct research on safer materials and products that protect human health and the environment by avoiding chemicals of concern, including carcinogens, asthmagens, mutagens, neurotoxicants, reproductive toxicants, endocrine disruptors, and chemicals that are persistent, and/or bioaccumulative.

Sample Language - Technical Design Standards

Technical Design Standards documents help clearly and concisely communicate your standards, including preferences and recommendations, to the team of Consultants and Contractors who work on renovation and construction projects. Compliance with these standards are often a contractual requirement for contractors.

GENERAL REQUIREMENTS (or similar section) SUSTAINABLE DESIGN (or similar subsection)

BASIC SERVICES - SCHEMATIC DESIGN SERVICES (or similar section) MATERIALS RESEARCH/SPECIFICATIONS Services (or similar subsection).

Consultant shall include: less toxic materials specifications or materials lists reviewed by third-party certification programs; safer products which are already commercially available to the extent that is practical; safer options that also limit premium costs and overall lifecycle costs.

BASIC SERVICES - DESIGN DEVELOPMENT SERVICES (or similar section) MATERIALS RESEARCH/SPECIFICATIONS Services (or similar subsection)

(Note: Add to existing section language) Consultant shall include research for safer materials and products that protect human health and the environment by avoiding chemicals of concern, including carcinogens, asthmagens, neurotoxicants, reproductive and developmental toxicants, and endocrine disrupting chemicals, among other type of hazards.

Sample Language: Invitations to Bid

The sample language included in this section is intended for use in Invitations to Bid (ITBs) for building construction and renovation or public improvement projects.

This sample language is designed to compliment traditional ITB language, including projects pursuing Leadership in Energy & Environmental Design (LEED) certifications. It strengthens traditional ITB language including LEED requirements by emphasizing the importance of protecting human health through the use of safer, less-toxic building products.

This language can be used verbatim or modified for incorporation into ITB template documents including the pursuant contract documents, or used for individual projects.

This sample language should be customized for your organization by changing the **[bracketed]** language. Bracketed “Note” language is included as a reference for ITB developer and can be removed if desired.

Simply cut and paste this language into the relevant sections of any existing ITB documents to improve the value and sustainability of the project while reducing risk and liability.

Sample Language - Building Construction or Renovation ITBs

Section [X] – Drawings and Specifications (or similar section)

[X.X] Product and Material Health & Safety Standards

[X.X.X] Standards Overview & Purpose

[Organization] is committed to protecting the health of building occupants, employees, children, and the environment by using safer, less toxic products and materials on this project. To the greatest extent possible, [Organization] prefers to use safer products and materials that do not contain chemicals of concern as defined in item **[X.X.X. Priority Product Classes]** below. Prospective bidders can support this commitment by ensuring that the standards set forth in this section are adhered to during project planning and delivery.

[X.X.X] Priority Product Classes

[Organization] is focused on product categories that represent the highest potential for human and environmental exposure to toxic chemicals during building construction and use. These categories of products and materials include, but are not limited to, the following with accompanying Construction Specifications Institute MasterFormat divisions for reference:

Div 03 Concrete, Div 04 Masonry, Div 05 Metals, Div 06 Wood, Plastics, Composites, Div 07 Thermal and Moisture Protection, Div 08 Openings, Div 09 Finishes, Div 10 Specialties, Div 11 Equipment, Div 12 Furnishings, Div 32 Exterior Improvements, Div 33 Utilities

[Note: Additional information about toxic chemicals typically found in products within these divisions is available here: <http://transparency.perkinswill.com/Home/PrecautionaryList>]

[X.X.X] Priority Chemicals of Concern

[Organization] wants to limit risk by reducing exposure to products and materials that contain priority chemicals of concern scientifically linked to toxicity in humans or ecosystems. On this project, to the greatest extent possible, Contractor will avoid the use of products that contain chemical ingredients like those found on the Living Building Challenge Red List and the following classes of chemicals: Volatile organic compounds, phthalates, heavy metals, perfluorinated chemicals, chlorinated chemicals, and halogenated flame retardants.

[X.X.X] Authority

[Organization] pursues safer, healthier building products and materials under the authority of **[Organization's risk management, environmentally preferable procurement, green building, sustainability, or other relevant policies]**.

Sample Language: Requests for Proposals

The sample language included in this section is intended for use in Requests for Proposals (RFPs) for building-related services on new construction and renovation projects.

It is designed to compliment traditional proposal language including references to Leadership in Energy & Environmental Design (LEED) certifications. It strengthens traditional proposal language including LEED requirements by emphasizing the importance of protecting human health through the use of safer, less-hazardous building products.

This language can be used verbatim or modified for combined services including Architectural and Engineering (A&E) services and Construction Manager/General Contractor (CM/GC) services. This language can also be modified for Architectural, Engineering, Construction Manager, and General Contractor services provided individually.

Simply cut and paste this language into the relevant sections of an existing RFP to improve the value and sustainability of the services provided on the project. This sample language should be customized for your organization by changing the **[bracketed]** language.

Sample Language - Architectural & Engineering Services RFPs

Relevant RFP Sections:

Introduction, Project Overview, Purpose, Scope of Work/Scope of Services, Proposal Requirements

Introduction/Project Overview/Purpose

Maintaining healthy workplaces and public spaces is a priority for [Organization]. Architects and Engineers have an important role to play in protecting human health and the environment on this project by identifying and specifying safer building products.

Scope of Work/Scope of Services (“LEED”, “Living Building Challenge”, “Green Building”, “Sustainable Design”, or similar subsection)

[Organization] prioritizes the use of building materials and products that are safer for people and the environment. In pursuit of Leadership in Energy and Environmental Design (LEED) v4 certification, this project is required to achieve points for the Materials & Resources credit with specific emphasis on MRc4 “Building Product Disclosure and Optimization – Material Ingredients”. Additionally, products used in this building should avoid chemicals ingredients found on the Living Building Challenge’s Red List.

Proposal Requirements (“Experience with Sustainable Design”, “Experience with Green Building Design”, “Experience with LEED Projects”, or similar subsections)

Describe your team’s experience designing safer buildings using products including those that do not contain chemical ingredients identified on the Living Building Challenge’s “Materials Petal” Red List or other relevant lists of chemicals of concern like the U.S. EPA’s Chemicals of Concern list. Describe the process by which your team identifies and specifies safer, less hazardous building products.

Sample Language - Construction Manager/General Contractor Services RFPs

Relevant RFP Sections:

Introduction, Scope of Work, Scope of Services, Proposal Requirements

Introduction (Project Overview, Purpose, or similar section)

Maintaining healthy workplaces and public spaces is a priority for [Organization]. Contractors and subcontractors have an important role to play in protecting human health and the environment on this project by using safer building products.

Project Goals and Development Principles (or similar section – Design/Build Option)

The goals and development principles below reflect [Organization’s] values and commitment to sustainability in both the building and development process.

Goal: Achieve Leadership in Energy and Environmental Design (LEED) version 4 Platinum certification or better, with an emphasis on points in the “Indoor Environmental Quality” and “Materials & Resources” categories.

Principle: Construction and Operational Sustainability – Use durable, safer building materials and products with transparent ingredient lists and the fewest possible hazardous chemicals that will deliver low long-term operational costs and an easy-to-maintain, functional, healthy, and efficient facility.

Scope of Work/Scope of Services (“LEED”, “Living Building Challenge”, “Green Building”, “Sustainable Design”, or similar subsection)

[Organization] prioritizes the use of building materials and products that are safer for people and the environment. In pursuit of Leadership in Energy and Environmental Design (LEED) v4 certification, this project is required to achieve points for the Materials & Resources credit with specific emphasis on MRc4 “Building Product Disclosure and Optimization – Material Ingredients”. Additionally, products used in this building should avoid chemicals ingredients found on the Living Building Challenge’s Red List.

Proposal Requirements (“Experience with Sustainable Construction Practices”, “Experience with Green Buildings”, “Experience with LEED Projects”, or similar subsections)

Describe your team’s experience building with safer building products including those that do not contain chemical ingredients identified on the Living Building Challenge’s “Materials Petal” Red List or other relevant lists of chemicals of concern like the U.S. EPA’s Chemicals of Concern list. Describe the process by which your team, including your subcontractors, identifies and purchases safer, less hazardous building products.

Sample Language - Janitorial Services

The following sample language can be used in solicitations for janitorial services. It should be customized for your organization by changing the **[bracketed]** language.

The [Organization] places a high priority on the health of employees and our environment. That means [Organization] prefers hiring service providers that use products and methods of cleaning and sanitation that are safer for human health and protect ecosystems. Proposers shall provide at least two examples of how they identify and select products and methods that avoid hazardous chemicals for your customers.

Examples could include, but are not limited to, the use of only third-party certified products, using EPA's Design for the Environment (DfE) cleaning products, requiring vendors to identify safer products using fully disclosed Healthy Product Declarations (HPDs), or meeting the requirements of Leadership in Energy & Environmental Design (LEED) v4 Green Cleaning – products and materials credit (EQc7).

Sample Language - Clean Diesel Construction

The following sample language can be used in RFPs for construction services where diesel equipment (generators, equipment, vehicles, etc.) will be used. It should be customized for your organization by changing the **[bracketed]** language.

[Organization] places a high priority on the health of employees and our environment. Increasing studies link diesel particulate matter to serious public health impacts from aggravating asthma to heart and lung problems to cancer and premature mortality. Diesel exhaust also has environmental significance as a global warming contributor. As such, [Organization] is interested in working with contractors that are taking steps to reduce their diesel emissions through “clean diesel” engines. “Clean diesel compliant” includes the following:

- A. Any diesel powered vehicle with an USEPA certified model year 2007 or newer engine, or
- B. Non-road diesel equipment certified as USEPA Tier 4, or
- C. Any diesel powered vehicle or non-road diesel equipment that has been retrofitted with a diesel particulate filter verified by USEPA or the California Air Resources Board, or
- D. Any medium-duty or heavy-duty vehicle or non-road equipment powered by alternative fuels like propane, natural gas, electricity, or biodiesel blends greater than 50%.

Proposers shall address the following in their response:

1. Please identify the quantity (total number and percent of your vehicle fleet and non-road equipment) that is clean diesel compliant.
2. Does your firm require the rental of diesel vehicles or non-road diesel equipment that is clean diesel compliant? If yes, please describe how this preference is implemented.
3. Does your firm require subcontractors to utilize diesel vehicles and non-road equipment that is clean diesel compliant? If yes, please describe how this preference is implemented.
4. Does your firm have an idle reduction policy for its construction projects? If so, please provide a copy of the policy and describe how it is implemented.
5. If your firm does not currently have these requirements, will you comply with them in the performance of these contracts? Which ones?

Product vendor outreach

Promoting information exchange with your vendor and contractor pool will support informed decision-making and amplify the impact of your healthy building efforts. It can provide vendors and contractors with the opportunity and motivation to engage their suppliers and manufacturers, and allow them to differentiate themselves through value-added services like product screening.

Clearly communicating about the importance of human health will lead to the creation of safer chemistries and innovative products now and in the future, opening the door to better value, more competition, and lower costs.

To further foster information exchange and open communication with vendors and contractors, use the sample vendor letters on the following pages. It should be customized for your organization by changing the **[bracketed]** language.

Vendor Letter - Flame Retardants in Furniture

The following sample letter is drafted for communicating about toxic flame retardants in furniture. It should be modified for your organization by changing the **[bracketed]** language.

[Date]
[Company]
[Attention]
[Address]

Re: Safer alternatives to chemical flame retardants in furniture

To Whom It May Concern:

As you may know, in January 2014 a new furniture flammability standard was adopted by the California Bureau of Home Furnishings and Thermal Insulation. We welcome the updated standard, Technical Bulletin 117-2013 (TB 117-2013), which will improve fire safety without requiring the use of flame retardant chemicals.

[Organization] is interested in purchasing products that do not contain flame retardant chemicals (including classes of organohalogens and organophosphate based flame retardants). Scientific studies show that these chemicals can migrate out of the products and into our air, dust and water. These chemicals then find their way into our food, bodies and the environment. Many of these chemicals are known to be persistent, bioaccumulative and toxic. Scientific studies in humans show changes in thyroid and reproductive hormones, alterations in the male reproductive tract, reduced sperm quality, and adverse impacts on brain development associated with higher exposures to various flame retardants. Some flame retardants are mutagens and likely to be carcinogenic.

Most notably, these chemicals have not been shown to actually improve fire safety in furniture and instead have led to the widespread use of, and exposure to, flame retardant chemicals nationally.

As your company frequently supplies the **[Organization]** with furniture products, we want to notify you that once TB 117-2013 is fully adopted by manufacturers in January 2015, we will seek and prefer those products that do not contain flame retardant chemicals. Thus, we encourage you to work with your supply chains to eliminate these flame retardants from the products you sell and move to safer alternatives.

As part of this switch to safer alternatives we encourage your company to provide a publicly available Health Product Declaration (HPD) (<http://hpdcollaborative.org/>) and/or Declare Label for the products you sell. The transparent disclosure of this information in a consistent manner enables us to make fully informed purchasing decisions and the **[Organization]** is currently considering whether to require HPDs in future furniture solicitations.

We also urge your company to consider endorsing and implementing principles for safer chemicals such as those developed by the Business-NGO Working Group (<http://www.bizngo.org/safer-chemicals/principles-for-safer-chemicals>).

Thank you for your attention to this issue. We ask that you respond to this letter with relevant information about what you may already be doing to identify, disclose, and eliminate hazardous chemicals like flame retardants from products you make or sell, and/or plans you have to provide products free of flame retardant chemicals after January 2015.

Sincerely,

[Purchasing Manager, Project Manager, Analyst, Sustainability Manager or other relevant staff]

Vendor Letter - General

The following sample letter is drafted for communicating more generally about healthier buildings and future solicitations. It should be customized for your organization by changing the **[bracketed]** language.

[Date]
[Company]
[Attention]
[Address]

Re: Changes to future solicitations to encourage healthier buildings

To Whom It May Concern:

[Organization] is committed to protecting the health of the public, our employees, and our natural environment.

Doing business with companies that are responsible and offer the best overall value is also an important of our efforts. Our emerging perspective on the quality of goods and services is one that includes consideration of chemical hazard and toxicity to humans and ecosystems. When factors like cost and availability are the same, products that avoid chemicals of concern and use safer alternatives represent a better value in our opinion.

Future contracts from **[Organization]** may include specifications or requirements related to chemical hazard disclosure and avoidance. This information will help us make more informed decisions.

Our initial focus includes goods and services purchased to design, construct, and maintain buildings. One reason we are focused on our built environment because there is strong industry leadership in green building services and products. Research also shows that there is strong potential for extended exposure to hazardous chemicals given the amount of time we spend indoors.

[Organization] wants to take a harmonized approach and use existing tools to support our healthy purchasing efforts. We believe it will save time and money for us both. For example, some future contracts may require that vendors request product manufacturers to publicly disclose chemical ingredient hazard(s) through a Health Product Declaration (HPD) (<http://hpdcollaborative.org/>) and/or Declare label and use that information to identify products that are safer for people and ecosystems.

We also urge your company to consider endorsing and implementing principles for safer chemicals such as those developed by the Business-NGO Working Group (<http://www.bizngo.org/safer-chemicals/principles-for-safer-chemicals>).

Thank you for your attention to this issue. We ask that you respond to this letter with relevant information about what you may already be doing to identify, disclose, and eliminate hazardous chemicals like flame retardants **[or other relevant classes of chemicals/chemicals of concern]** from products you make or sell.

Sincerely,

[Purchasing Manager, Project Manager, Analyst, Sustainability Manager or other relevant staff]

Relevant resources

Oregon Department of Administrative Services Green Chemistry Procurement Guidelines

These guidelines are designed to helping agencies to procure safer products and reduce chemicals of concern, protect public health, and foster innovation by encouraging the design and use of safer products through procurements and awards.

Leadership in Energy & Environmental Design (LEED)

LEED is a green building certification program that recognizes best-in-class building strategies and practices. To receive LEED certification, building projects satisfy prerequisites and earn points to achieve different levels of certification. Prerequisites and credits differ for each rating system, and teams choose the best fit for their project. Points are awarded in the USGBC's LEED v4 standard for products verified to minimize the use and generation of harmful substances using the GreenScreen® for Safer Chemicals. [Link](#)

GreenScreen for Safer Chemicals

GreenScreen for Safer Chemicals is a scientifically based, open method for assessing how chemicals can impact human health and the environment. It is used by a wide range of professionals, governmental bodies, non-profits, businesses, formulators, and product developers. [Link](#)

Health Product Declaration

The Health Product Declaration (HPD), an impartial tool for the accurate reporting of product contents and each ingredient's relationship to the bigger picture of human and ecological health. The HPD objectively defines the critical information needed to support accurate supply chain disclosure by manufacturers and suppliers, and informed decisions by building designers, specifiers, owners, and users. [Link](#)

The Living Building Challenge Red List

The Living Building Challenge™ calls for the creation of building projects at all scales that operate as cleanly, beautifully and efficiently as nature's architecture. It is a building certification program, advocacy tool and philosophy that defines the most advanced measure of sustainability in the built environment. Certification requires compliance with all aspects of seven performance categories called Petals: Place, Water, Energy, Health & Happiness, Materials, Equity and Beauty. The Materials Petal, which includes a 'Red List' of banned chemicals, is designed to encourage a healthy materials economy that is non-toxic, transparent and socially equitable. [Link](#)

Declare

Declare® is a program of the International Living Future Institute and a transparency tool created in support of the Living Building Challenge Materials Petal requirements and aligned with the Red List. The program is relevant to all parties seeking product ingredients and source location information. By providing a clear and informative "nutrition label" and a publicly accessible database of building products, Declare facilitates effective communication between manufacturers, building product specifiers and consumers. [Link](#)

Perkins+Will Precautionary List

Design and planning firm Perkins+Will has developed a precautionary list used in their projects. The list is searchable by chemical name, category of chemicals, health effects, and divisions and sections is intended for product specifiers and building owners, but is useful for everybody in the building design and construction industry.

Healthy Building Network Pharos Project

The Pharos Project encourages manufacturers to disclose all ingredients in building products; helps architects, designers and building owners avoid using products that contain harmful chemicals; and creates incentives for product redesign and modification to reduce the impacts of hazardous materials use throughout the lifecycle of building products.

Office Furniture Survey and Guide

The Center for Environmental Health provides guidance for purchasers in “Kicking Toxic Chemicals Out of the Office: An Easy Guide to Going Flame Retardant-Free”, along with information about manufacturers that make office furniture without toxic flame retardant chemicals.

Cost of Green Revisited

This Davis Langdon report evaluated the feasibility and cost impact of sustainable design in the light of increased market adoption. Key findings include: Many projects are achieving LEED within their budgets, in the same cost range as non-LEED projects, construction costs have risen dramatically, but projects are still achieving LEED, and the idea that green is an added feature continues to be a problem.

The Business Case for Green Building

The U.S. Green Building Council has assembled an impressive set of data and information about the cost effectiveness of green building. Included in the findings are that LEED buildings, including those that use safer, less toxic products, lead to improved health and productivity benefits for tenants.

References

- ¹ Conway, D. M. (2012). Sustainable Procurement Policies and Practices at the State and Local Government Level. Chapter 3 from *Greening Local Government* K. Hirokawa & P. Salkin, eds., 2012. SSRN: <http://ssrn.com/abstract=2095576>.
- ² Kung HC, Hoyert DL, Xu JQ, Murphy SL. Deaths: final data for 2005. *National Vital Statistics Reports* 2008;56(10). http://www.cdc.gov/nchs/data/nvsr/nvsr56/nvsr56_10.pdf
- ³ United States Centers for Disease Control and Prevention (CDC). (2013). Asthma's Impact on the Nation: Data from the CDC National Asthma Control Program. http://www.cdc.gov/asthma/impacts_nation/asthmafactsheet.pdf
- ⁴ Landrigan, P. J., Collins, G., Galvez, M., Sheffield, P. & Forman, J. (2013). New York State's Children and the Environment. *Children's Environmental Health Center, Icahn School of Medicine at Mount*
- ⁵ U.S. Department of Health and Human Services. (2011). Report on Carcinogens: Twelfth Edition. *National Toxicology Program*. <http://ntp.niehs.nih.gov/ntp/roc/twelfth/roc12.pdf>
- ⁶ CDC. 2005. National Report on Human Exposure to Environmental Chemicals: Third Report. Atlanta, GA:Centers for Disease Control and Prevention. <http://www.cdc.gov/exposurereport/report.htm>
- ⁷ U.S. Environmental Protection Agency. 1989. Report to Congress on indoor air quality: Volume 2. EPA/400/1-89/001C. Washington, DC.
- ⁸ United States Centers for Disease Control and Prevention. (2013). Chronic Disease Cost Calculator Version 2. <http://www.cdc.gov/chronicdisease/resources/calculator/index.htm>.
- ⁹ Wu, N. et al. (2007). Human Exposure to PBDEs: Associations of PBDE Body Burdens with Food Consumption and House Dust Concentrations. *Environmental Science & Technology*. Retrieved from <http://pubs.acs.org/doi/abs/10.1021/es0620282>.
- ¹⁰ Watanabe, I. & Sakai, S. (2003). Environmental release and behavior of brominated flame retardants. *Environment International*. Retrieved from <http://www.sciencedirect.com/science/article/pii/S0160412003001235>.
- ¹¹ Betts, KS (2010). Endocrine damper? Flame retardants linked to male hormone, sperm count changes. *Environmental Health Perspectives*. Retrieved from <http://www.ncbi.nlm.nih.gov/pmc/articles/PMC2854790/>
- ¹² Herbstman, JB, Sjödin, Andreas, Kurzon, M, Lederman, SA, et al. (2010). Prenatal exposure to PBDEs and neurodevelopment. *Environmental Health Perspectives*. Retrieved from <http://www.ncbi.nlm.nih.gov/pmc/articles/PMC2866690/>
- ¹³ Messer, A (2010). Mini-review: polybrominated diphenyl ether (PBDE) flame retardants as potential autism risk factors. *Physiology & Behavior*. Retrieved from <http://www.ncbi.nlm.nih.gov/pubmed/20100501>
- ¹⁴ Healthy Building Network. (2006). Screening the Toxics Out of Building Materials. Retrieved from http://www.healthybuilding.net/pdf/Healthy_Building_Material_Resources.pdf
- ¹⁵ Frederiksen, M, Vorkamp, K, Thomsen, M & Knudsen, LE (2009). Human internal and external exposure to PBDEs--a review of levels and sources. *International Journal of Hygiene and Environmental Health*. Retrieved from <http://www.ncbi.nlm.nih.gov/pubmed/17079016>.

- ¹⁶ Costa, LG & Giordano, G (2007). Developmental Neurotoxicity of polybrominated diphenyl ether(PBDE) flame retardants. *Neurotoxicology*. Retrieved from <http://www.ncbi.nlm.nih.gov/pubmed/17904639>
- ¹⁷ Liu, C. et al. (2013). Effects of tris(1,3-dichloro-2-propyl) phosphate and triphenyl phosphate on receptor-associated mRNA expression in zebrafish embryos/larvae. *Aquatic Toxicology*. <http://www.usask.ca/toxicology/jgiesy/pdf/publications/JA-713.pdf>
- Healthy Building Network. (2012). Target Materials: Overview. Retrieved from http://www.healthybuilding.net/target_materials.html
- ¹⁸ Strynar, MJ. & Lindstom, AB. (2008). Perfluorinated Compounds in House Dust from Ohio and North Carolina, USA. *Environmental Science & Technology*. Retrieved from <http://pubs.acs.org/doi/abs/10.1021/es7032058>.
- ¹⁹ Tao, L., Kannan, K., Wong, CM, Arcaro, KF, Butenhoff, JL. (2008). Perfluorinated Compounds in Human Milk from Massachusetts, U.S.A. *Environmental Science & Technology*. Retrieved from <http://pubs.acs.org/doi/abs/10.1021/es702789k>.
- ²⁰ Viberg, H & Eriksson P. (2011). Chapter 47 – Perfluorooctane sulfonate (PFOS) and perfluorooctanoic acid (PFOA). *Reproductive and Developmental Toxicology*. Retrieved from <http://www.sciencedirect.com/science/article/pii/B9780123820327100475>.
- ²¹ European Commission. (2004). Lifecycle assessment of PVC and principle competing materials. Retrieved from http://ec.europa.eu/enterprise/sectors/chemicals/files/sustdev/pvc-final_report_lca_en.pdf.
- ²² Wagoner, JK. (1983). Toxicity of vinyl chloride and (poly)vinyl chloride: a critical review. *Environmental Health Perspectives*. Retrieved from <http://www.ncbi.nlm.nih.gov/pmc/articles/PMC1569348/>.
- ²³ U.S. Environmental Protection Agency. (2012). EPA's Reanalysis of Key Issues Related to Dioxin Toxicity and Response to NAS Comments, Volume 1. Retrieved from <http://www.epa.gov/iris/supdocs/dioxinv1sup.pdf>.
- ²⁴ Healthy Building Network. (2006). Screening the Toxics Out of Building Materials. Retrieved from http://www.healthybuilding.net/pdf/Healthy_Building_Material_Resources.pdf
- ²⁵ Sack, TM., Steele, DH., Hammerstrom, K. Remmers, J. (1992). A survey of household products for volatile organic compounds. *Atmospheric Environment. Part A. General Topics*. Retrieved from <http://www.sciencedirect.com/science/article/pii/096016869290038M>
- ²⁶ U.S. Environmental Protection Agency. (2012). An Introduction to Indoor Air Quality (IAQ): Volatile Organic Compounds. Retrieved from <http://www.epa.gov/iaq/voc.html>.
- ²⁷ Nielson, GD. & Wolkoff, P. (2010). Cancer effects of formaldehyde: a proposal for an indoor air guideline value. *Archives of Toxicology*. Retrieved from <http://www.ncbi.nlm.nih.gov/pubmed/20467865>.
- ²⁸ Brown, SK, Sim, MR, Abramson, MJ, & Gray, CN. (2004). Concentrations of Volatile Organic Compounds in Indoor Air: A Review. *International Journal of Indoor Environment and Health*. Retrieved from <http://onlinelibrary.wiley.com/doi/10.1111/j.1600-0668.1994.t01-2-00007.x>
- ²⁹ U.S. Environmental Protection Agency. (2012). Care for Your Air: A to Indoor Air Quality. Retrieved from <http://www.epa.gov/iaq/pubs/careforyourair.html>.
- ³⁰ Healthy Building Network. (2012). Target Materials: Overview. Retrieved from http://www.healthybuilding.net/target_materials.html
- ³¹ Strynar, MJ. & Lindstom, AB. (2008). Perfluorinated Compounds in House Dust from Ohio and North Carolina, USA. *Environmental Science & Technology*. Retrieved from <http://pubs.acs.org/doi/abs/10.1021/es7032058>.

- ³² Tao, L., Kannan, K., Wong, CM, Arcaro, KF, Butenhoff, JL. (2008). Perfluorinated Compounds in Human Milk from Massachusetts, U.S.A. *Environmental Science & Technology*. Retrieved from <http://pubs.acs.org/doi/abs/10.1021/es702789k>.
- ³³ Viberg, H & Eriksson P. (2011). Chapter 47 – Perfluorooctane sulfonate (PFOS) and perfluorooctanoic acid (PFOA). *Reproductive and Developmental Toxicology*. Retrieved from <http://www.sciencedirect.com/science/article/pii/B9780123820327100475>.
- ³⁴ U.S. Consumer Products Safety Commission. (2010). Overview of Phthalates Toxicity. Retrieved from <http://www.cpsc.gov/about/cpsia/phthalover.pdf>.
- ³⁵ U.S. Consumer Products Safety Commission. (2010). Overview of Phthalates Toxicity. Retrieved from <http://www.cpsc.gov/about/cpsia/phthalover.pdf>.
- ³⁶ Lyche, JL., Et al. (2009). Reproductive and developmental toxicity of phthalates. Retrieved from <http://www.ncbi.nlm.nih.gov/pubmed/20183522>.
- ³⁷ Australian Department of Health and Aging. (2008). Existing Chemical Hazard Assessment Report for Di-n-hexyl Phthalate. Retrieved from <http://www.nicnas.gov.au/Publications/CAR/Other/DnHP%20hazard%20assessment.pdf>
- ³⁸ US Department of Health and Human Services, National Toxicology Program, Center for the Evaluation of Risks to Human Reproduction (CERHR). (2003). Monograph on the potential human reproductive and developmental effects of Di-n -Hexyl Phthalate (DnHP). Retrieved from http://cerhr.niehs.nih.gov/evals/phthalates/dnhp/DnHP_Monograph_Final.pdf
- ³⁹ Solomon, M. (2012). Gypsum Board: Are Our Walls Leaching Toxins? *Building Green: GreenSpec*. Retrieved from <http://greenspec.buildinggreen.com/blogs/gypsum-board-are-our-walls-leaching-toxins>.
- ⁴⁰ Vallette, J. (2010). Mercury Contamination of Drywall. *Pharos*. Retrieved from <http://www.pharosproject.net/blog/detail/id/40>.
- ⁴¹ Trasande, L, Landrigan, PJ, & Schechter, C. (2005). Public Health and Economic Consequences of Methyl Mercury Toxicity to the Developing Brain. *Environmental Health Perspectives*. Retrieved from <http://www.ncbi.nlm.nih.gov/pmc/articles/PMC1257552/>.
- ⁴² Grandjean P, et al. (1997). Cognitive deficit in 7-year-old children with prenatal exposure to methylmercury. *Neurotoxicology and Teratology*. Retrieved from <http://www.ncbi.nlm.nih.gov/pubmed/9392777>.
- ⁴³ Mutter, J., Naumann, J., Sadaghiani, C., Schneider, R., & Walach, H. (2004). Alzheimer Disease: Mercury as pathogenic factor and apolipoprotein E as a moderator. *Neuroendocrinology Letters*. Retrieved from http://www.keytoxins.com/hgbiblio-files/neurological/mutter_neuroendocrin_itr_04_Hg_alzheimer%27s.pdf.

Appendix 01.12
All Gender Restroom Policy

All-Gender Restroom Policy

INTRODUCTION

October, 2017

On August 11, 2015 the Capital Advisory Committee (CAC) approved the creation of an all-gender (also sometimes referred to as gender-neutral, unisex, or universal) restroom policy at Portland State University. The all-gender restroom policy was developed by the Standards Committee (a subcommittee of the Capital Advisory Committee) and the Campus Planning Office in collaboration with the Office of Global Diversity and Inclusion and the Queer Resource Center.



PURPOSE

Portland State University promotes access, inclusion and equity as pillars of excellence and believes that everyone should be treated with dignity and respect. Many people may experience difficulty and inconvenience when required to use gender-specific restrooms. The all-gender restrooms policy is intended to address several issues that are associated with gender-specific restrooms:

- Individuals who don't conform to stereotypical notion of gender often struggle when faced with two restroom doors
- Parents and caregivers with different gender children
- Community members with disabilities who need assistance from a different gender caregiver
- Some individuals are territorial about policing gender in public restrooms, creating situations that may lead to harassment towards trans and gender nonconforming people, different gender caregivers, and people with disabilities.

DEFINITIONS

All-gender single occupancy restroom: Any single occupancy restroom that does not designate a gender and can be used by any gender or gender identity. These restrooms will be included in new construction or major renovations with lower anticipated occupancy loads.

Gender specific single occupancy restroom: Any single occupancy restroom that has been designated men or women. Existing restrooms designated as such will transition to all-gender single occupancy restrooms in accordance with the all-gender restroom policy.

All-gender single occupancy (family): An all-gender single occupancy restroom that has been designated for family use. Existing single occupancy restrooms designated for family use will remain designated for family use.

All-gender multi-stall: Any multi-stall restroom that does not designate a gender and can be used by any gender or gender identity. These restrooms will be included in new construction or major renovations in accordance with the all-gender restroom policy's occupancy loads.

Gender specific multi-stall: Any multi-stall restroom that has been designated men or women. Existing gender specific multi-stall restrooms will remain as gender specific restrooms (except where capacity and code allows for a restroom to be repurposed as an all-gender restroom).

SCOPE

The all-gender restroom policy in this document applies to the construction of new buildings and major renovations of existing buildings, as well as existing buildings with gender-specific single occupancy restrooms. When feasible the all-gender restroom policies will be implemented in existing buildings that are not slated for renovation or that do not currently have gender-specific single occupancy restrooms. The all-gender restroom policy is intended to add accessible, inclusive, and safe restroom options for the Portland State University community.

ALL-GENDER RESTROOM POLICY

At least one multi-stall and/or single occupancy all-gender restroom will be created in renovated or newly constructed buildings. Occupancy loads will be the determining factor in the creation of a multi-stall all-gender restroom. A multi-stall all-gender restroom will be created if the following occupancy loads will exist in a building:

- a) 50+ FTE employees and 200+ students, or
- b) 100+FTE, or
- c) 400 students

If the above occupancy loads will not exist in a newly constructed or renovated building, then the construction of at least one single-occupancy all-gender restroom will be created.

Additionally, all buildings that currently have single-occupancy gender-specific restroom will be converted to all-gender restrooms. The conversion of these restroom will be dependent on funding and will be converted as funding becomes available.

ALL-GENDER RESTROOM IMPLEMENTATION PLAN

As of March 2016, Portland State University has 44 single-occupancy restrooms, 29 of which are designated as all-gender restrooms. In the spring of 2016, the Student Building Fee Committee approved funding to convert the remaining 15 gender-specific restrooms to all-gender restrooms. The conversion of these restrooms is anticipated to be completed by the start of the Fall 2016 term.

Approximately, two years ago the Smith Memorial Student Union created a five-stall all-gender restroom. In the spring of 2016, the Student Building Fee Committee additionally approved funding to convert the two third floor restrooms in the Millar Library (ML) to a four-stall and two-stall all-gender restrooms as well as creating a two-stall all-gender restroom on the fifth floor of Science Building One (SB1). The conversion of these restrooms are anticipated to be completed by the start of the Fall 2016 term.

Additionally, Portland State University has two major building renovations, the Karl Miller Center (KMC) and the Viking Pavilion at Peter Stott Center (PSC). Both of these projects will include a four-stall all-gender restroom. Construction for KMC is anticipated to be completed by Fall 2017 and construction for PSC is anticipated to be completed early 2018.

REQUIRED DESIGN STANDARDS

The all-gender restroom policy will be incorporated in Portland State University's Technical Design Standards (TDS) and will use the same fixtures and stalls as indicated in the TDS Appendix 01.6 – Restroom Preferences.

- A. Partition panels will include gap-free interlocks to eliminate sight lines. Partitions heights should not exceed 5'-10" in height and shall be installed so that a 12" gap is maintained between the bottom of the partition and the floor.
- B. Changing station will be included in all new and remodeled restrooms
- C. Single occupancy restroom will include ADA lever/closer hardware with secured locks that include occupancy indicators.
- D. Urinals will not be included in multi-stall restrooms
- E. Sanitary napkin disposals will be included in every stall
- F. Signage will conform to PSU Campus Planning Office requirements (appendix 01.7) and will include a standard symbol (pictogram) of a toilet and the verbiage "All Gender" with braille translation.

RECOMMENDED DESIGN STANDARDS AND LOCATION

The following design recommendations should be incorporated when feasible. The locations of all-gender restrooms will be determined by Capital Project & Construction project managers and should consider the following location recommendations:

- A. Doorless entries to restrooms are encouraged
- B. Multi-stall restrooms should be four stalls or more
- C. Multi-stall restrooms will include informational signage with the following verbiage:
"This all gender restroom provides facilities that are safe, accessible, and convenient to all people, including all gender identities and expressions and people who require attendants or caregivers of a different gender."

THIS ALL GENDER RESTROOM PROVIDES FACILITIES THAT ARE SAFE, ACCESSIBLE, AND CONVENIENT TO ALL PEOPLE, INCLUDING ALL GENDER IDENTITIES AND EXPRESSIONS AND PEOPLE WHO REQUIRE ATTENDANTS OR CAREGIVERS OF A DIFFERENT GENDER.

THIS ALL GENDER RESTROOM PROVIDES FACILITIES THAT ARE SAFE, ACCESSIBLE, AND CONVENIENT TO ALL PEOPLE, INCLUDING ALL GENDER IDENTITIES AND EXPRESSIONS AND PEOPLE WHO REQUIRE ATTENDANTS OR CAREGIVERS OF A DIFFERENT GENDER.

- D. Multi-stall all-gender restrooms should be located in high-traffic areas and given the same location preference as gender-specific restrooms
- E. When feasible, gender-specific restrooms should be within close proximity
- F. When feasible, the first floor should be avoided for single-occupancy all-gender restrooms

Appendix 01.13
Water Efficiency Assessment Policy

Introduction

Portland State University (PSU) understands that lower potable water use for toilets, showerheads, faucets, and other plumbing fixtures reduces water withdrawn from underground aquifers and from rivers, streams, and other water bodies that support aquatic ecosystems. Reduced water consumption also minimizes the amount of water discharged to municipal water treatment facilities, lowering chemical inputs and the need for new treatment infrastructure. PSU acknowledges that water heating in commercial buildings can account for nearly 15% of building energy use¹ and that conservation measures also reduce energy use and energy-related pollution.

Scope

This plan applies to all PSU properties. In the event that any domestic water fixture is required to be replaced in a building, PSU Technical Design Standards will be used. Technical Design Standards will be updated in accordance with this policy, and can be accessed at: <https://www.pdx.edu/construction/technical-design-standards>

Goals

To reduce indoor fixture and fitting water use and to reduce the burdens on potable water supply and wastewater systems. PSU design standards for water fixtures will be assessed on an ongoing basis and at least every other year using an economic assessment to explore opportunities to increase water efficiency through plumbing fixtures/fittings.

Water savings will be calculated between existing design standards and higher-performing plumbing fixtures/fittings.

Procedure and Strategies

An economic calculator will be used to evaluate updating design standards. In sum, the plumbing design standards will be evaluated based on the following:

- a. Economics of municipal domestic/potable water supply savings
- b. Economics of municipal sewage waste water discharge/treatment savings
- c. Economics of other maintenance savings or added costs (i.e. any applicable replacement parts, urinal cartridges, etc.)
- d. Uniform Building Code 2006 (UPC)
- e. International Plumbing Code 2006 (IPC)
- f. USGBC LEED Water Efficiency Credit Requirements
- g. Energy Policy Act of 1992 Flow Requirement

Responsible Parties

PSU Capital Projects & Construction and Facilities & Property Management Departments are jointly responsible for:

- Monitoring overall effectiveness of the program
- Reviewing water efficiency economic assessment
- Updating design standards based on cost: benefit of water savings

PSU Facilities & Property Management Department is responsible for:

- Collecting water cost data, reviewing historical trends, and maintaining an inventory of all water fixtures on site
- Monitoring overall effectiveness of the reduced flow fixtures
- Reporting functionality problems as well as maintaining the fixtures according to manufacturer's instruction
- Plumbing fixture and fitting inspection, testing, and preventive maintenance program

Time Period

This Policy is effective March 1st 2017 and will be in effect for the duration of building operations.

Relevant Definitions

Nonpotable water is water that does not meet EPA's drinking water standards, and therefore, is not suitable for human consumption.

Plumbing fixtures and fittings are receptacles, devices, or appliances that are either permanently or temporarily connected to the building's water distribution system and receive liquid or liquid-borne wastes and discharge wastewater, liquid-borne waste materials, or sewage either directly or indirectly to the drainage system of the premises. This includes water closets, urinals, lavatories, sinks, showers, and drinking fountains.

Potable water is water suitable for drinking that meets or exceeds EPA drinking water standards; it is supplied from wells or municipal water systems.

Substantial completion is defined as either initial building construction or the last plumbing renovation of all or part of the building that included a 100% retrofit of all plumbing fixtures and fittings as part of the renovation.

¹ Energy Information Administration, 1999 Commercial Buildings Energy Consumption Survey, retrieved May 2008. www.eia.doe.gov/emeu/cbecs/.

Appendix 01.14
Solid Waste Management

Introduction

Under the direction of the Campus Sustainability Office (CSO), Portland State University (PSU) encourages source reduction, reuse, and recycling of materials used in the operations and maintenance of the campus. Acknowledging that the campus generates significant amounts of waste, PSU has identified and prioritized waste diversion strategies to reduce demand for new materials and related harvesting or extraction of natural resources. Additionally, PSU acknowledges that disposal of solid waste by incineration or land filling produces greenhouse gas emissions and should be avoided through waste reduction and recycling whenever possible.

Scope

This plan applies to PSU's entire campus and addresses the following waste streams within the University's control:

- Ongoing Consumables
- Durable Goods
- Facility Alterations and Additions
- Mercury Containing Lamps
- Batteries

Procedure and Strategies

Ongoing Consumables

Examples include, but are not limited to: paper, plastics, cardboard/OCC, metals, glass, food scraps, toner cartridges, and batteries. All building occupants will be encouraged to recycle paper, plastics, cardboard/OCC, metals, glass, toner cartridges, and batteries, and to compost food scraps. Provisions will be made for building occupants through collection stations which will be placed throughout campus buildings according to the following guidelines:

- Approved paper recycling bins will be provided at each shared copier / printer station and serviced by contracted custodial services.
- Centralized waste stations for recycling and garbage will be provided for open office areas. Additionally, staff can opt to obtain a desk-side recycling container that they can empty at waste stations at their convenience.
 - PSU custodial contractors do not service individual, desk-side trash cans. Building occupants are responsible for emptying their own trash and recycling containers into centralized collection containers.
 - Centralized waste stations are serviced by contracted custodial services and all recycling bin contents are hauled to a materials recovery facility by our contracted hauler.
- A battery recycling bin will be provided for all general office areas. The bins will be emptied upon request via work order.
- An approved waste collection system will be provided for all kitchen / breakroom areas. The waste station will be specifically used for comingled plastic bottles/tubs, metal cans, paper, and cardboard, as well as a separate bin for glass. Signage at waste stations will clarify what materials may be deposited. These waste stations will be serviced nightly.

- An approved collection bin for food scraps and food soiled paper (paper napkins, paper towels, coffee filters, etc.) will be provided in all kitchens /breakrooms and collected for composting. Signage will clarify what materials may be deposited.
- All recyclables will be captured and contained in clear plastic bags so that contaminants can easily be spotted and removed. This will reduce contamination and allow more waste to be recycled.
- PSU does not provide bins in individual classrooms. We instead implement an “All in the Hall” approach by placing centralized midpoint recycling stations in hallways. This recognized best practice is a common strategy at universities across the country as it increases waste diversion and reduces costs. PSU’s “All in the Hall” program encourages greater waste diversion by bringing people to a central location where ALL waste management options are present.

Durable Goods

Examples of durable goods include, but are not limited to, office equipment (computers, monitors, copiers, printers, scanners, and fax machines), appliances (refrigerators, dishwashers, and water coolers), furniture (systems furniture, conference tables, and guest chairs), external power adapters, and televisions and other audio-visual equipment. *Building occupants are required to place a work order for surplus pick-up for all usable and working durable goods.* If no longer usable, the following items are required to be recycled:

- **Electronic equipment** (computers, monitors, copiers, printers, scanners, and fax machines), external power adapters, and televisions and other audio-visual equipment via work order for Environmental Health + Safety (EHS):
- **Appliances** (refrigerators, dishwashers, and water coolers) via work order for EHS
- **Furniture** (systems furniture, conference tables, and guest chairs) via work order for PSU Surplus
- **All unwanted and usable office supplies should be donated to the Campus Reuse Room located in Cramer Hall, Room 180.**

Facility Alterations and Additions

Examples include, but are not limited to, building components and structures (wall studs, insulation, doors, windows); panels; attached finishing (drywall, trim, ceiling panels); carpet and other flooring material; adhesives and sealants; and paints and coatings. Mechanical, electrical, plumbing, furniture, fixtures and equipment are excluded.

- PSU maintenance staff and construction contractors working on tenant improvements as well as larger renovations on campus will be required to recycle building components and structures (wall studs, insulation, doors, windows); panels; attached finishing (drywall, trim, ceiling panels); carpet and other flooring material; adhesives and sealants; and paints and coatings.
- Old and un-repairable carpet tiles will be stored for collection by PSU’s contracted hauler or carpet manufacturer where possible for recycling.
- Project Managers will work with general contractors to ensure provisions for construction waste recycling .
- All weight tickets for construction and demolition recycling should be routed to PSU’s Waste Management Coordinator to track performance and identify areas for improvements.

Mercury Containing Lamps

- Per PSU's [Sustainable Procurement and Life Cycle Considerations Policy](#), new lamps must meet the LEED credit for reduced mercury in lamps: 70 picograms per lumen-hour or less.
- When lamps are removed, the hazardous waste laboratory (managed by EHS) will collect them upon waste pickup requests made via the Facilities work order system. Lamps will then be picked up and processed by a lamp recycling agent in accordance with all State and federal requirements for managing hazardous lamps pertaining to the Universal Waste Rule.
- PSU will take advantage of manufacturer take back programs where possible.

Batteries

- Per PSU's [Sustainable Procurement and Life Cycle Considerations Policy](#), rechargeable batteries should be purchased for standard office use.
- All departments will be provided a battery collection bucket with a dated Universal Waste sticker and instructions for submitting a work order to EHS for pickup and proper disposal.
- Batteries are picked up and processed by EHS, who ships them to various battery recycling facilities depending on the type of battery to be recycled.

Performance Metric

Currently, performance is tracked on a monthly basis using waste and recycling invoices which calculate weights based on an estimation of 150 pounds per 1 yard of waste collected from campus. Beginning in 2017, waste and recycling containers will be metered to provide more accurate weights and performance will be measured based on this data.

Goals

This solid waste management policy aims to reduce the amount of solid waste and toxins that are hauled to and disposed of in landfills or incineration facilities by encouraging the reuse and recycling of items and the composting of food scraps, where possible. The following sustainability goals are challenging, but achievable:

Ongoing-Consumables: Reuse, recycle or compost 70% of ongoing consumable items and food scraps in the total waste stream (by weight)

Durable Goods: Reuse/recycle 75% of durable goods in the total waste stream (by weight or volume)

Facility Alterations and Additions: Divert at least 70% of construction waste (by weight or volume) from facility alterations and additions

Mercury Containing Lamps: Divert 100% of all mercury containing lamps

Batteries: Divert at least 80% of all batteries

Quality Control and Assurance

To verify and assure the procedures and performance metrics of this policy are successfully implemented and achieved, the Waste Management Coordinator, within the Campus Sustainability Office, will periodically inspect waste management practices throughout the year through waste audits. These inspections include a review of how solid waste is generated, handled, and disposed; the types of materials designated for the landfill; how durable goods are removed from the ongoing consumable waste stream; and the methods used for disposing of construction waste. The Waste Management Coordinator will also track and review performance metrics at least semi-annually and the contents of this policy annually.

Responsible Party

Implementation, oversight, and the quality assurance of this Solid Waste Management Policy is the responsibility of the Campus Sustainability Office and the Waste Management Coordinator. *This Policy is effective February 1, 2017 and will be reviewed on an annual basis.*

Definitions

Comingled recycling: a system in which all paper fibers, plastics, metals, and other containers are mixed in a collection truck, instead of being sorted by the depositor into separate commodities.

Durable goods: goods with a useful life of two years or more and are replaced infrequently and/or may require capital program outlays. Examples include furniture, office equipment, appliances, external power adapters, and televisions and other audiovisual equipment.

Incinerator: a furnace or container for burning waste materials.

Landfills: waste disposal sites for solid waste from human activities.

Ongoing consumables: materials with a low cost per unit that are regularly used and replaced through the course of business. These include paper, toner cartridges, binders, batteries, and desk accessories.

Recycling: the collection, reprocessing, marketing, and use of materials that were diverted or recovered from the solid waste stream.

Reuse: when materials are returned to active use in the same or related capacity thus extending the life of materials that would otherwise be disposed. Examples of ongoing consumables that can be reused include binders, staplers, and other desk accessories, whether they are reused on-site or donated to other facilities.

Source reduction: reducing the amount of unnecessary material brought into a building. Examples include purchasing products with less packaging and that are designed with sustainability in mind.

Waste: all materials that flow from the building to final disposal. Examples include paper, grass trimmings, food scraps, and plastics. Waste refers to all materials that are capable of being diverted from the building's waste stream through waste reduction, including source reduction, recycling, and composting.

Waste diversion: a management activity that disposes of waste other than through incineration or landfilling. Examples are reuse and recycling waste.

Waste reduction: source reduction and waste diversion through reuse or recycling.

Waste reduction program: (1) the organization's commitment to minimizing waste disposal by using source reduction, reuse, and recycling; (2) assigned responsibility within the organization for implementation of the program; (3) the general actions that will be implemented to reduce waste; and (4) tracking and review procedures to monitor waste reduction and improve waste reduction performance.

Waste stream: is the overall flow of wastes from the building to a landfill, incinerator, or other disposal site.

Portland State University Waste Container Standards

Many containers and signs across Portland State University (PSU) are in need of updating to optimize waste reduction and diversion. The Campus Sustainability Office (CSO) aims to modernize and standardize university waste management systems from containers and signs to processes and programs. Several guiding principles inform our approach:

Consistency: Building occupants should be presented with the same waste management options throughout campus.

Consolidation: Right-sizing and centralizing our infrastructure is key to an effective, affordable, and user friendly waste management system.

Accessibility: Every landfill bound trash bin should be paired with diverse recycling options. Most of the waste we produce can be diverted from the landfill and recycling should be as accessible to building occupants as possible.

Permanence: Our waste management system, including containers, should communicate a lasting university commitment to waste reduction.

Safety: Containers should be safe to operate, service, and maintain.

Preparedness: Standardized containers enable architects, project managers, and design teams to anticipate space needs for waste receptacles and integrate them into the design of the building and reduce unexpected challenges.

Flexibility: Containers should be moveable to maximize effectiveness and adaptable to respond to changing markets or community needs.

Kitchens, breakrooms, study lounges, lobbies, hallways, and corridors

CLEANRIVER MIDPOINT RECYCLING STATIONS

Midpoint tri-sorting waste collection stations are the approved waste receptacles for hallways within student centered buildings such as classroom buildings, Smith Memorial Student Union, and Viking Pavilion. They are also the approved standard for other common areas such as kitchens, break rooms, lobbies, and study lounges. Midpoints provide a centralized, convenient, flexible, and uniform system for waste management. Distinct sections of the station can be customized and are adaptable to changing markets or community needs. The entire unit can be moved if needed and is easily serviced and maintained. The Waste Management Coordinator within CSO coordinates procurement of Midpoint waste stations to ensure compliance. **Built-in waste systems are not permitted due to the inflexibility they create.**



Midpoint Recycling Station – Specifications:

Dimensions: 41.25" x 18.00" x 37" x 51.00", Weight: 185 lbs.

3 streams – Landfill, Commingled Recycling, and Glass

Manufactured with 97% recycled material

Model	No. of Streams	Dimensions	Weight	Price
IMSF-3 Flat Backboard	3	41.25" x 18.00" x 37" x 51.00"	185 LBS	\$

Position	Stream	Opening	Capacity	Bag Size
1	Landfill	9x9 Square	22 USG	32"x43"
2	Mixed Recycling	9x2x5 Saturn	22 USG	32"x43"
3	Recycle: Glass & Jars	5.5 Round with Baffle	22 USG	32"x43"

IMSF-3 is designed for easy servicing; the unit has front opening doors and rigid liners. Heavy duty casters allow the unit to be moved for cleaning or repositioning. Color coded compartments and top plates standardize your facility wide program.

Midpoint Recycling Station – Signage:

CSO creates and approves signage for ALL waste containers, including Midpoint waste stations. CSO may choose to update or change signage over time due to changing markets, rules, or community needs. The signage used across campus is an amalgamation of institutional best practices, contractual requirements, and refinement over time, so any proposed changes should be sent to the waste management coordinator in CSO for review and approval to ensure all needs and requirements are being met.

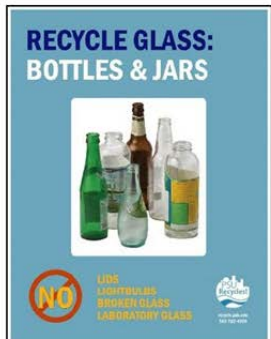

Kitchens, breakrooms, study lounges, and approved public spaces

SIMPLEHUMAN COMPOST CANS

33% (by weight) of landfill-bound waste on campus consists of food waste and compostable fibers such as napkins, coffee filters, tea bags, and paper plates. Food waste not only takes up valuable space in the already overtaxed landfill but it also emits the potent greenhouse gas, methane, as it decays. When composted, food waste becomes a beneficial soil amendment. PSU is committed to both food waste reduction and composting. Stainless steel, SimpleHuman containers with lids and push pedals are the standard compost container for kitchenettes and breakrooms, as well as most public spaces on campus.

38-Liter (10-Gallon) SimpleHuman Step Waste Cans

Specifications:

Dimensions: 12.5"D x 15.8"W x 25.9"H

Weight 14.3 lbs.

Brushed stainless steel with finger-proof coating

Strong steel pedal

Dent-proof lid has shocks technology for a smooth, silent close

Internal hinge allows for placement right up against the wall

Estimated price (2017) - \$ 99.99



Residence Halls

PORTLAND COMPOSTS! PAILS*

Sure-Close Kitchen Composter – Specifications:

Dimensions: 9"D x 11"W x 9.5"H

Weight 1.1 lbs.

HDPE plastic includes recycled content, UV protected

Dishwasher safe and compostable bag liner ready

Easy fit under sink, cupboard, countertop or in a corner

Hinged lid that clicks open and swinging handle with lip grip, bottom grip and back grip

Inside is smooth and easy to clean with patented airflow channels and microperforated

lid that seals out fruit flies and insects, reduces smells with aeration



HOUSING RECYCLING BIN*

Rehrig Pacific Company 6-Gallon Apartment Recyclers – Specifications:

Dimensions: 13"D x 12"W x 13"H

Weight 2.2 lbs.

Made with durable, washable, 100% recyclable, high density poly-ethylene (HDPE) resin

**PSU's Housing & Residence Life (HRL) provides housing recycling and compost bins. HRL charges students for bins if not left in the room when moving out.*



Shared and individual offices – desk side containers

BUSCH SYSTEMS BUDDY BINS

Most of the waste created in an office setting is recyclable. Using a trash/recycling buddy system for waste collection is the most effective way to increase capture of recyclable materials generated in offices. By pairing all trash bins with a larger recycling bin, it is more convenient for users to dispose of waste properly. Similar to PSU's "All in the Hall" program regarding classrooms, PSU DOES NOT service individual, desktside trash cans. Building occupants are responsible for emptying their own trash and recycling containers into centralized collection containers. These designated centralized collection points are then serviced by custodians. CSO recommends one of two different options when setting up desk-side waste collection in offices.

Busch Systems Recycling & Hanging Waste Bin - Specifications:

14-quart (3.5 gallon) blue recycling bin and smaller (0.75 gallons) hanging trash bin

Dimensions: 11.5"D x 7.9"W x 12"H

Weight: 1.05 lbs.



City of Portland's Sustainability at Work desktside recycling box:

The Campus Sustainability office can provide these for building occupants.

Individuals would still have to acquire their own trash can if one is desired,

but the recycling desktside box is provided free of cost from the City of Portland.

You can contact PSU Recycles at 503-725-4300 or through e-mail recycles@pdx.edu

to request a desktside cardboard recycling box for your office.



Printer and copier areas

BUSCH SYSTEMS SLIM JIMS

The Campus Sustainability Office recommends one of two different options when setting up paper recycling collection in printer/copier/fax areas:

Busch Systems Waste Watcher Recycling Bin - Specifications

Dimensions: 20"D x 11"W x 30"H

Weight: 6.75 lbs. (7.65 lbs. with lid)

23-Gallon capacity (also available in 16- and 20- gallon containers)

Lid Specification: Mixed (Saturn Style) container lid with 5" diameter circle inside a slot that 16 1/4" D x 1 3/4" W



City of Portland Sustainability at Work Central Collection Container

Dimensions: 18”D x 12”W x 26”H

You can contact PSU Recycles at 503-725-4300 or through e-mail recycles@pdx.edu to request the central collection cardboard recycling box for your office.



Outdoor spaces: plazas, entrances, walkways, parking garages, etc.

STREETSCAPE OUTDOOR RECYCLING / GARBAGE RECEPTACLE WITH RAIN HOOD

Portland State aims to pair all outdoor garbage cans with recycling containers with landfill-bound waste receptacles is one small step to assisting with university sustainability goals and increasing opportunities for our campus community to recycle no matter where they are on campus.

Recycleaway Streetscape 36-gallon Recycling Receptacle with Rain Hood – Specifications

Dimensions: 26”D x 42”H, Weight: 145 lbs., 35.5 gallon capacity

Recycle Blue gloss finish, Garbage Black gloss finish

Weather resistant EXL-COAT powder coat finish is durable enough for any climate

1.5” wide x 3/16” thick welded steel bars

Bottom consists of steel channels so unit can be secured to the ground if desired

Adjustable leveling glides keep unit stable on uneven surfaces

Lid is secured to unit with plastic coated steel cable to prevent vandalism

Color matched removable LLDPE plastic liner with lift openings meets UL94 Flammability Standard

Made in the USA

Estimated price (2017) Recycling - \$ 999.99, Garbage - \$ 939.99



Temporary roll-off containers

The following images serve as a size and planning reference for PSU staff needing large temporary waste containers. These containers are delivered and serviced by our waste hauler. Need a large temporary trash dumpster? Feel free to e-mail recycles@pdx.edu or call 503-725-4300 for assistance from one of our waste management specialists.

What size do you need?

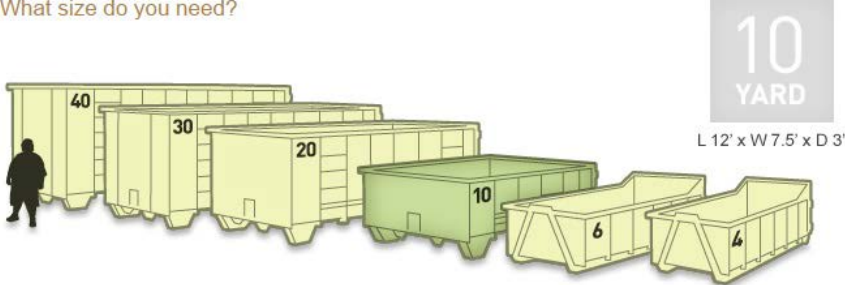

What size do you need?

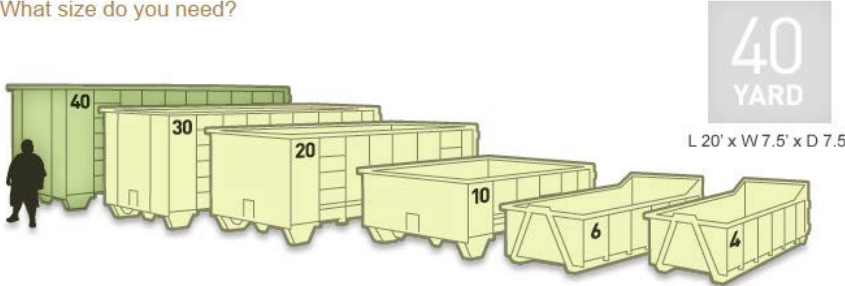

What size do you need?

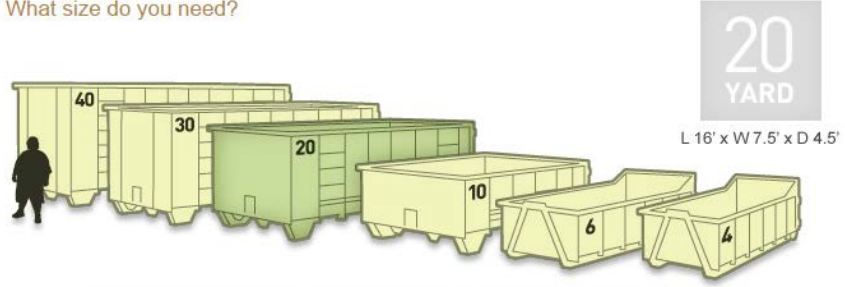

What size do you need?

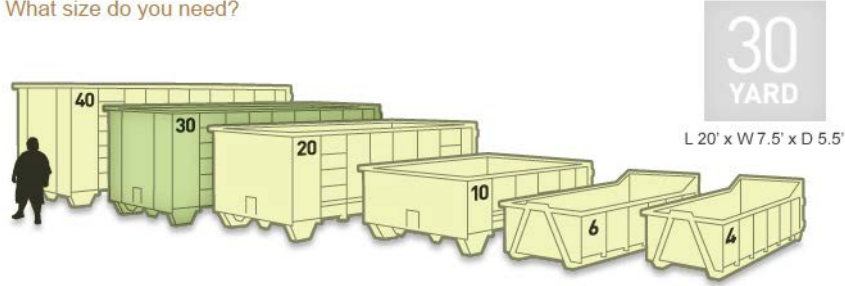

Roll off vehicle configuration

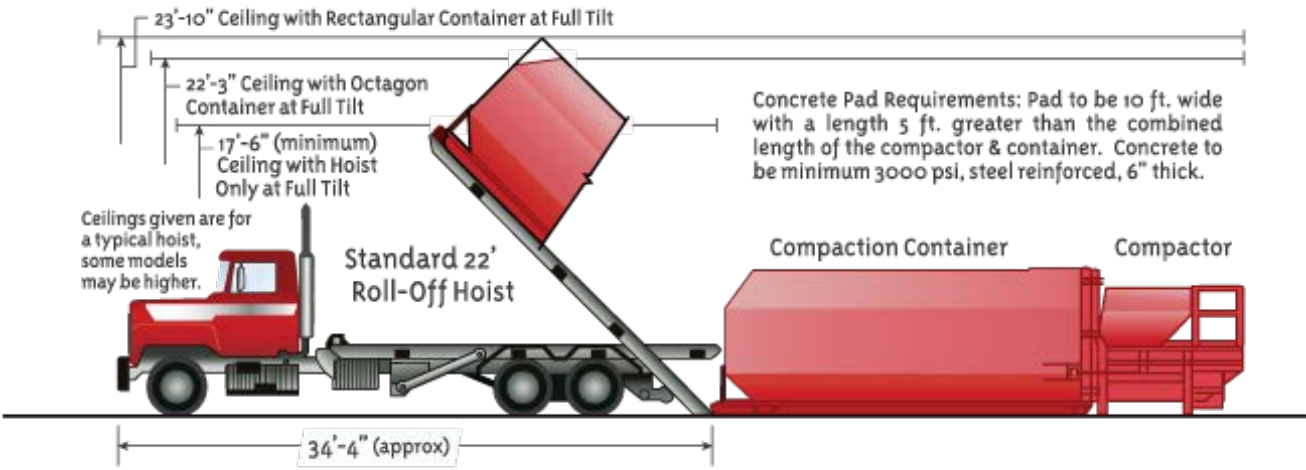

Front end load vehicle configuration

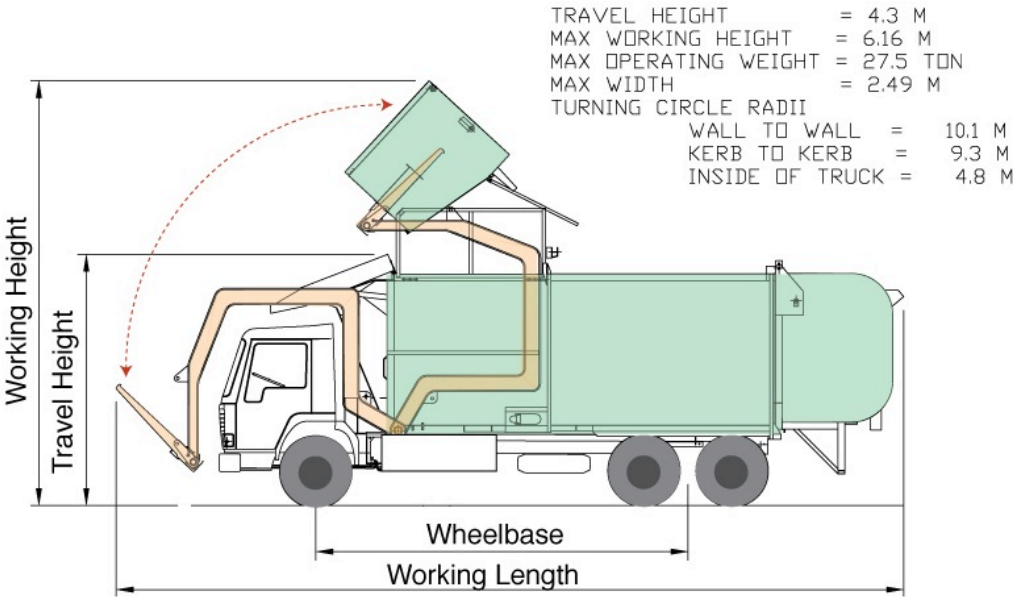

Concrete pad requirements

Pad to be 10 feet wide with a length of 5 feet greater than the combined length of the compactor and container. The concrete should be a minimum of 3000 psi, steel reinforced, and 6" thick.

APPENDIX: Outdated containers found on campus but no longer purchased

Office Style Bins
GeoCube Recycling Containers
Witt Industries



Commingle "Candy"
Smooth, blue steel recycling Canables®
Windsor Barrel Works



Curbside/Curby:
Used throughout the Metro area for
residential glass recycling



Ribbed Bullet
Ribbed, blue steel
recycling can
Witt Industries



Dome Top Can
Used on campus for
garbage in public
spaces

Warriors:
Stations with locking doors on front



Appendix 08.1
Door Hardware

PORTLAND STATE UNIVERSITY
DESIGN AND CONSTRUCTION STANDARDS

APPENDIX 08.1 – **DOOR HARDWARE**

1. STANDARDS OF PERFORMANCE

- a. All doors to be a complete and functioning, installation approved per code, City of Portland bldg. dept., and the ADA.
- b. Standard hardware finish is ANSI 626 or US26D, Lever style to match existing.
- c. Supply and install all door hardware including temporary lock cylinders; temporary cores (also known as “construction cores”) to be Schlage large format interchangeable temporary cores.
- d. Deliver keys to PSU Project Manager.
- e. Coordinate with PSU all required card access control system installations.
- f. Contractor to remove, box, label and deliver all existing hardware on demolished doors, as shown on the demo plan, in coordination with direction received from PSU Project Manager.
- g. If existing office, restroom, or exit doors that remain in area of work don't have approved ADA hardware installed, then replace with new ADA lever/closer hardware described in these notes.
- h. All hardware to be manufactured, specified, and installed per specifications and standards per the Steel Door Institute & Door & Hardware Institute.
- i. Review all hardware operation settings with PSU locksmith prior to final city permit inspector review.
- j. Provide to PSU Project Manager complete hardware submittal list for review and approval prior to ordering and construction.
- k. Provide to PSU at Closeout complete hardware instructions, manufacturer's recommendations and specifications, service manuals and warranty information.
- l. Verify existing conditions.
- m. Verify electrical boxes and conduit runs as required.
- n. Accessible Doors to provide adequate framing for motors and clearance from EXIT signage.
- o. No floor closures allowed.

2. PRODUCTS

a. ACCEPTABLE LOCK TYPE, MANUFACTURER, AND TRIM

i. Cylindrical Lockset	Schlage ND W/Vandelguard	RHO or SPA
ii. Mortise Lock	Schlage L series	06B or 17B
iii. Exit Device #1	Von Duprin 99/98 series	996L 06 or 17 347T EO (no outside trim)
iv. Exit Device#2	Von Duprin 33A /35A	388 or 360L-06/-17 360T EO (no outside trim)

**PORTLAND STATE UNIVERSITY
DESIGN AND CONSTRUCTION STANDARDS**

v. Delayed Egress Exit	Von Duprin Chexit	996L 06 or 17 EO (no outside trim)
vi. Dead Bolt	L series	
vii. Electric Strikes	Von Duprin, HES	
viii. Temporary Lock/cylinder TD	Schlage large format interchangeable core housing	
ix. Door Closer	LCN 4040 series	
x. Door Opener	LCN Senior Swing, LCN 4600 Electric Auto Equalizer, LCN 4800 Pneumatic Equalizer	
xi. Hinge, Ballbearing, NRP	Hager, Stanly, Mckinney	
xii. Hinge, Plainbearing, NRP	Hager, Stanly, Mckinney	
xiii. Manual Flush Bolts	Ives FB457, FB458	
xiv. Auto Flush Bolts	Ives FB30/40 series	
xv. Drawer Lock	Olympus 888icp-dw Olympus 920 lm/dm	
xvi. Cabinet Door	Olympus 777icp-dr Olympus 920 lm/dm	
xvii. Access Panels	Olympus 920 lm/dm	
xviii. Cylinders	Schlage	
xix. Butts	Stanley, McKinney, Lawrence	
xx. Electric transfer hinge	Von Duprin	
xxi. Key switch	Von Duprin/Schlage	
xxii. Exit devices	Von Duprin	
xxiii. Locksets and latches	Schlage	
xxiv. Stand alone access control	Schlage AD 200 series, Schlage CO 200 series	
xxv. Astragal	Pemko	
xxvi. Door Stops	Glen Johnson, Ives	
xxvii. Push Pull	Builders Brass	
xxviii. Kickplates	Builders Brass, Trimco	

PORTLAND STATE UNIVERSITY
DESIGN AND CONSTRUCTION STANDARDS

xxix. Thresholds and weatherstrip	Pemko
xxx. Door operators (ADA)	LCN
xxxi. Automatic door sensors (ADA)	B.E.A.
xxxii. Door actuators (ADA)	BEA, LCN, Camdeu, Curran
xxxiii. Door holders	LCN

b. FINISH

- i. Match existing building standard or ANSI 626 or US26D

d. TYPICAL HARDWARE LIST

- i. Reference Door Schedule and details and Specification Sheets
- ii. Match existing finishes.

d. LOCKS AND HANDLES

- i. Manufacturer: Schlage or approved equal
- ii. Match existing lever style and color
- iii. Use Schlage "ND Vandeguard series" -- ND92
- iv. Storeroom lock-- ND96LD
- v. Lever Passage lock -- ND10S,
- vi. Lever Privacy lock -- ND40S.
- vii. Pocket door latch 990 series.
- viii. Exit rim and panic bar devices by Von Duprin 98 series at all assembly areas, doors that out-swing from a room, or other areas specified on drawings

e. CARD ACCESS DOORS

- i. Provide/Install all transformers or other electrical devices and hardware required to support card access for locks and panic bars.
- ii. Strikes to be ansitype 10-025, electric as required for card access.
- iii. Key card access control at exterior entry point. Retro-fit existing or provide at new doors for electric strike. Coordinate with existing PSU system, door hardware, or power opening device.

f. BUTTS

- i. Manufacturer: Lawrence, Stanley, McKinney or approved equal
- ii. (1-1 1/2) pr., to be ball bearing type, use non-removable-pin, on doors with closers.
- iii. All other doors, use plain bearings, (1-1 1/2) pr., with non-removable-pin.

g. DOOR STOPS

- i. Manufacturer: Ives, Glen Johnson or approved equal
- ii. Wall mount type WS 407 - 2-1 1/2" dia.

h. SMOKE GASKETS

PORTLAND STATE UNIVERSITY
DESIGN AND CONSTRUCTION STANDARDS

- i. Manufacturer: Pemko or as approved approved equal.
 - ii. AM 88, black, at all doors in fire corridors on all levels.
 - i. BI-FOLD HARDWARE
 - i. Manufacturer: Bi-Fold Hardware, Johnson, or approved equal
 - ii. Use complete hardware model #200 FD including track , pivots, butts, ball bearing roller guides, and brackets ,
 - iii. Door handles -- 7" wire pulls --.Baldwin or approved equal
 - j. ADA POWER DOOR OPENER
 - i. Manufacturer: LCN Senior Swing or approved equal, LCN 4600 Electric Auto Equalizer and LCN 4800 Pneumatic Auto Equalizer.
 - ii. Complete electric opener/closer mounted at door head pull side to include (2) wall plate actuators, with key card access at exterior. Retro-fit for ANSI 10- 025 electric strike. Actuators ADA wall mount each side of door. Accommodate lever hardware with and key lock operation. Satin chrome finish.
 - iii. Activate existing power door opener and install exterior wall plate actuator adjacent to door latch access. Retro-fit for ANSI 10-025 electric strike.
 - k. CARD ACCESS DOORS
 - i. Provide/Install all transformers or other electrical devices and hardware required to support card access for locks and panic bars.
 - ii. Strikes to be ansitype 10-025, electric as required for card access.
 - iii. Key card access control at all exterior entry points, including to roof, and at department suite entry and exit points. Retro-fit existing or provide at new doors for electric strike. Coordinate with existing PSU system, door hardware, or power opening device."
1. EXECUTION
- a. INSTALLATION
 - i. Install per manufacturer's specification and recommendation.
 - ii. For installation of locks, use manufacturer's fasteners that come with the hardware.
 - iii. For installation of door closers, use manufacturer's wood/metal fasteners pack; do not use self-tapping sheet metal screws.
 - iv. For electric locks, supply a wiring and a schematic diagram, show locations of power supplies and wire runs.
 - v. Spring hinges and continuous hinges not allowed.
 - vi. Prefer that on metal doors that external exit vertical device rods are not used; Ok to use on wood doors.
 - vii. F. Prefer door assembly installation of welded 16 gauge door frames for break-in deterrent.

END OF SECTION

Appendix 27.1
Structured Cabling Standards

Structured Cabling Standards

OIT Telecommunication Systems | Fiscal Year 14

The **PSU Structured Cabling System** includes:

- vertical and horizontal copper and fiber optic wiring
- the associated termination hardware on both ends (e.g. jacks, patch panels)
- pathways and conduit
- equipment racks, frames, wire management systems
- telecom closets and voice/data core rooms
- system documentation including database records, maps, inventory and tracking labels

The below specifications are intended to allow OIT-TS to economically meet the voice and data communications requirements of the University over the lifetime of the buildings. It is essential that OIT-TS is consulted prior to and throughout the planning and design process for additions or modifications to campus structured cabling systems to ensure that present and future service requirements can be met and that every effort is made to contain costs to the University.

General Standards

Construction specifications are crucial for a quality Information Technology system. Information Technology systems shall adhere to these specifications in order to be functional in a wide variety of communications applications. This document does not allow or condone the avoidance of following any of the Laws, Standards, or Procedures of any of, but not limited to, the following:

- National Electrical Code (NEC)
- Uniform Building Code (UBC)
- Uniform Fire Code (UFC)
- State of Oregon Low Voltage Laws
- Building Industry Consulting Services International (BICSI)
- ANSI/TIA/EIA Standards

Related Documents

Materials and equipment shall be manufactured, installed and tested as specified in the latest editions of applicable publications, standards rulings and determinations of:

- ANSI – American National Standards Institute
- TIA/EIA – Telecommunications Industry Association/Electronic Industry Alliance
- FCC – Federal Communications Commission
- BICSI – Telecommunications Distribution Method Manual
- NEC – National Electrical Code
- NFPA-70 – National Fire Protection Association

- ANSI/TIA/EIA-568 Commercial Building Telecommunications Cabling Standard
- TIA/EIA-568-B-2.1, Transmission performance specification for 4 pair 100 Ohm Category 5e and Category 6 cabling.
- ANSI/TIA/EIA-569A Commercial Building Standard for Telecommunications Pathway and Spaces
- ANSI/TIA/EIA-606 Commercial Building Standards for the Telecommunications Infrastructure and Spaces
- ANSI/TIA/EIA- 607 Commercial Building Grounding and Bonding Requirements for Telecommunications
- ANSI/TIA/EIA-TSB-67 Telecommunications System Bulletin Technical Systems Bulletin, Transmission Performance Specifications for Field Testing of Unshielded Twisted Pair Cabling Systems

General Wiring Installation Standards

Based on the standards, practices and procedures contained in the references listed above, the wiring of ***new buildings and major remodels of existing buildings*** shall use outlets, jacks, terminal blocks and horizontal wiring that are Category 6 compliant, all other installation shall be Category 5e compliant unless otherwise noted in the scope of work. Major remodels are classified as the total remodel of an existing building or floor within a building which requires the removal of all communications cabling and installation of new communications infrastructure.

For all PSU voice and data communications installations, PSU uses an open architecture design. Communications outlets at workstation and other jack locations shall minimally consist of two gang wall plates equipped with two 8-pin modular (RJ-45) jacks. ***The preferred standard for communications outlets in new construction is four gang wall plates equipped with four 8-pin modular (RJ-45) jacks.*** The number of modular jacks per face plate shall be decided by the use of the area and with the approval of OIT-TS. PSU has standardized on the TE Connectivity SL type workstation components. These components may be substituted with equivalent product only with the prior approval of OIT-TS. Horizontal station wire shall be plenum rated and extend from communications outlets to associated terminal closets and shall be terminated on Intermediate Distribution Frames (IDF's) using TE Connectivity modular patch panels. **All terminated station wiring shall be properly labeled at the outlet faceplate and the IDF per OIT-TS labeling standards.** A copy of the current labeling standard for a campus location will be provided by the OIT-TS Project Coordinator at the time of project commencement.

Terminal closet material standards include the following: 7' x 19" Chatsworth racking system including wire management and tray, TE Connectivity patch panels & Corning fiber optic connectivity housings and panels. TE Connectivity patch panel may be substituted with equivalent product only with prior approval of OIT-TS.

The riser system shall consist of multi-mode & single-mode fiber and Category 3 copper riser cable. The recommended fiber cable is multi-mode, graded-index optical fiber with a nominal 62.5/125 micron core/cladding diameter and single-mode fiber. The copper riser shall be solid copper, 24 AWG, twisted-pair Category 3 backbone cable. The cable jacket shall comply with Article 800 NEC for use as plenum or non-plenum wire, and all cabling and wiring installation shall comply with appropriate code for plenum or non-plenum requirements.

Certification

A BICSI-certified Registered Communications Distribution Designer (RCDD) shall design, engineer and sign off on all projects and will provide oversight during the project. A PSU OIT-TS staff member may meet the BICSI certified requirement if the Contractor does not have this resource available.

All technicians performing horizontal and riser cabling or wiring work must be certified or otherwise qualified in the installation of Category 6/5e wire, jacks, patch panels and terminal blocks. While contractors may choose to use less qualified personnel or workers who are not Category 6/5e certified for "wire pulling or rough in" work, all wire termination work must be performed by technicians who are certified Category 6/5e installers and testers. Contractors may be asked to provide documentation or similar evidence that technicians are qualified Category 6/5e installers and are current with ANSI/EIA/TIA standards. Failure to provide such evidence or documentation could result in the disqualification of the contractor and termination of the work order, service order, or installation agreement or contract.

The above standards describe the general cabling and wiring guidelines to be adhered to by all contractors performing structured cabling and wiring work at PSU. Any exceptions to these standards will be duly noted in the specific Scope of Work for each project. Any deviation from these standards that is not specifically allowed by OIT Telecommunication Systems (OIT-TS) or otherwise delineated in the Scope of Work could be grounds for disqualification of Contractor and termination of the installation agreement/contract.

Quality Control & Assurance Requirements

Testing and Documentation

Contractor shall test all cabling and wiring installed with an approved Category 6/5e tester performing a link test to at least 250 MHz to support a minimum of 1000Mbs Ethernet for Category 6 and a link test of 100 Mhz Ethernet for Category 5e following ANSI/TIA/EIA 568-B standards. Contractors shall test all installed fiber strands for cable integrity using a bi-directional Power Meter with a controlled light source at a wavelength of 850nm & 1300nm for multimode and 1310nm & 1550nm for single mode. Contractor shall record all test results. Any installations that fail the testing shall be corrected and retested. **All recorded results and related testing documentation, including those showing test failures, shall be provided to OIT-TS in electronic format.** OIT-TS reserves the right to randomly test the Category 6/5e throughput at various installation locations to ensure the accuracy and completeness of contractor testing. Should any of these tests fail, OIT-TS may withhold all, or some portion, of the payment due Contractor for wiring installation work.

Upon completion of the project a full set of as-builts shall be provided showing faceplate locations and jack numbers. Jack numbers on the as-builts MUST EXACTLY match physical labels at the installation site. The complete set of as-builts need to be delivered in both hardcopy and electronic format. *****a note about e911***** Oregon Senate Bill 598, implemented January 1 of 2014, requires organizations to report the physical street address of a 911 call to a Public Safety Answering Point (PSAP). PSU OIT-TS must have accurate information on jack locations and labels in order to enter this physical information in our database to report for e911.

Housekeeping and General Clean-up

Contractor shall ensure that all work areas are left in a clean, safe condition at the end of each workday or shift as well as at the end or completion of the entire project. Contractor is responsible only for that work they perform and resulting cleanliness or safety issues. Prior existing conditions are the responsibility of PSU.

Qualifications, Professionalism and Behavior of Contractor Employees

All technicians and other contractor employees performing work on PSU premises shall be highly qualified, skilled professionals who behave in a professional and courteous manner at all times. Contractor employees must have the ability to plan and organize their work efficiently and communicate effectively with OIT-TS staff and other customer contacts in the field.

OIT-TS places a strong emphasis on good customer service and fully expects all contractors and vendors to endorse this service ethic when deploying technicians and other employees on the PSU campus. All contractor technicians and employees shall wear appropriate work attire on the job and shall present themselves in a professional manner in terms of attire and overall appearance. At least one technician or employee per work group shall wear attire that includes the contractor or vendor logo, business name, etc.

Warranty of Work and Materials

Contractor must guarantee installation work, must warranty the fiber materials, if provided by the Contractor, and is required to describe the nature of Contractor's guarantee in the Bid Response or Quote submitted for this solicitation. The warranty shall cover manufacturing defects in material, if provided by the Contractor, and workmanship under normal and proper use, application assurance, and the installation of all materials.

The minimum warranty period for the installation of horizontal station wiring work shall be 5 years if PSU provides the materials and a minimum of ten years for labor and material if the Contractor provides the materials. Fiber installation warranty shall be a minimum of 5 years if PSU provides the fiber materials and 10 years for labor and materials if Contractor provides the materials.

Protection of Existing Equipment

All existing and active networking and telecommunications hardware installed in PSU campus buildings shall be protected prior to the start of any construction. ***It shall be Contractor's responsibility to effectively protect the owner's network and telecommunications facilities, equipment, and materials from dust, dirt and any other damage during construction.*** Contractor shall take no action that will interfere with, or interrupt, existing building network and telecommunications services unless previous arrangements have been made with OIT-TS or the appropriate building owner's representative. If any shutdown of network or telecommunications services or systems is required for Contractor to perform work, Owner's personnel will perform shutdown of affected systems. Contractor must provide Owner with a minimum of three (3) days' advance notice for such system shutdowns. ***Should Contractor cause network or telecommunications services or systems to be interrupted in any way, Contractor shall be solely responsible for all costs associated with satisfactorily restoring or replacing services or systems to include all labor and materials required to restore or replace services or systems.*** All service or system restoration or replacement by Contractor must be approved by OIT-TS.

Communications Facilities Requirements

Cramer Hall Telecom and Data Core

The main telephone equipment switchroom typically houses the telephone system (PBX) cabinets and servers; equipment racks for data networking equipment; UPS equipment; the wall field for cross-connecting the equipment cables, riser cables, intra-campus BET cables, and ILEC/CLEC entrance cables; a workstation; and storage space for maintenance spares, tools and test equipment.

At PSU, there are typically two types of switchrooms: 1) the main switchroom which houses the central PBX cabinetry that serves the entire campus; and 2) satellite switchrooms for remote PBX cabinets or voice gateways that are connected via leased or PSU owned outside plant facilities back to the main campus switchroom. Since the main switchroom for the campus is in place and rather permanent in nature, this facilities requirement addresses ***satellite switchrooms which typically are required for new off campus buildings or similar major facilities construction projects*** where it's more efficient and effective to install remote PBX cabinets or voice gateways versus extending additional cable plant facilities to serve extensions directly off the main PBX.

The minimum size requirement for a satellite switchroom is 10' x 15'. Minimum clear height in the room shall be 8 feet without obstructions. The access door to the room shall be at least 36 inches wide and 80 inches high, with doorsill, and shall be fitted with a lock. A minimum of two walls should be covered with rigidly fixed (3/4 trade size) A-C plywood preferably void free, 8ft. high, capable of supporting attached equipment. Plywood should be either fire rated or covered with two coats of fire retardant paint.

A separate power supply circuit serving the switchroom shall be provided and terminated in its own electrical panel. Power supply (including lights) in the switchroom shall be on emergency power. Power shall be sufficient to support the equipment load and supporting facilities for the switchroom. A 1-½ trade-size conduit shall be provided from the switchroom to the building grounding electrode.

The preferred location for the switchroom is the first floor (or ground floor) or a basement or sub-basement. It is desirable to locate the switchroom close to the main backbone network and building outside telephone company cable entrance site for ease of connectivity to these network and distribution facilities.

When selecting the room site, avoid locations that are restricted by building components that limit expansion such as elevators, core, outside walls or other fixed building walls. Ease of accessibility to the space is important for the delivery of large equipment. The switchroom shall be located away from sources of electromagnetic interference at a distance that will reduce the interference to 3.0 V/m throughout the electromagnetic frequency spectrum. Special attention shall be given to electrical power supply transformers; motors and generators; x-ray equipment; radio, cell phone or radar transmitters; and induction sealing devices. The switchroom shall be located with ready access to the main HVAC delivery system to ensure sufficient airflow and cooling.

HVAC shall be provided on a 24 hours-a-day, 365 days-per-year basis. The temperature and humidity shall be controlled to provide continuous operating ranges of 64° F to 72° F with 30% to 55% relative humidity. The ambient temperature and humidity shall be measured at a distance of 5 feet above the floor level, after the equipment is in operation, at any point along the equipment aisle. A positive pressure differential with respect to surrounding area should be provided.

The switchroom shall be provided with the proper fire suppression system. Appropriate portable fire extinguishers shall be provided and maintained within the switchroom. They should be located as close as practicable to the switchroom entry or exit. Additionally, some form of temperature alarm system should be installed to provide an early warning to a remote monitoring site of temperatures exceeding 75° F.

The interior finishes of the switchroom shall be light in color to enhance room lighting. The floors, walls and ceiling shall be sealed to reduce dust. Flooring materials having antistatic properties shall be used. Lighting shall be a minimum of 540 lx (50 candles) measured 3 feet above the finished floor in the middle of equipment aisles between cabinets. One or more switches located near the entrance door to the room shall control the lighting. **Lighting fixtures shall not be powered from the same electrical distribution panel as the telecommunications equipment in the room.** Emergency lighting and signs should be properly placed in the room where absence of light would hamper emergency exit.

Terminal Closets for Phone System and Data Networking Equipment

There shall be at least one terminal closet per floor. Additional closets should be provided when the floor area exceeds 10,000 sq. ft. or the horizontal distribution distance to the workstation exceeds 90 meter (300 ft). There are typically two size scenarios for terminal closets: 1) the ideal situation where there is ample space to provide a minimum closet size of 10 ft. by 8 ft. with a single door at least 30 inches wide and 80 inches tall, opening out; and 2) the limited space scenario where the closet size should be a minimum of 7 ft. wide and 30 inches deep, both of which are inside dimensions, provided the closet is accessed via double doors which swing out away from the closet. **In either scenario, the closet should be at least 8 feet high.**

Each closet shall have sufficient power and lighting. PSU's minimum power requirements are two dedicated 20 amp duplex power outlet per closet. Power supply (including lights) in the closet shall be on emergency power. Additionally, **each closet shall have adequate airflow to ensure that operating temperatures do not drop below 50° F or exceed 80° F.**

Closets shall be "centrally located" on each floor, or located so that horizontal station wires runs to user work stations and phones do not exceed 200 feet. The preferred standard for station wire is 150 feet.

Each closet shall have sufficient sleeves, slots, conduits, or similar floor penetrations necessary to allow for ease of installation of telecommunications cabling and wiring. Such penetrations shall be properly firestopped per the applicable building codes. A minimum of two walls should be covered with rigidly fixed (3/4 trade size) A-C plywood preferably void free, 8ft. high, capable of supporting attached equipment. Plywood should be either fire rated or covered with two coats of fire retardant paint.

Horizontal Pathways

Horizontal pathways and spaces consist of structure that conceal, protect and support horizontal cables between the workstation outlet and the telecommunications terminal closet. When designing a building, the layout and capacity of the horizontal distribution systems must be thoroughly documented in the floor plans and other building specifications.

Every ceiling distribution system must provide proper support for cables from the telecommunications terminal closet to the work areas it serves. ***Ceiling panels, support channels (T-bars), and vertical supports are NOT proper supports.*** Ceiling conduits, raceways, cable trays, and cabling must be suspended from or attached to the structural ceiling or walls with hardware or other installation aids specifically designed to support their weight. The pathways must have adequate support to withstand pulling the cables and be installed with at least 3 inches of clear vertical space above the ceiling tiles and support channels (T-bar) to ensure accessibility.

Conduit

Conduit types include electrical metallic tubing, rigid metal conduit, and rigid PVC. Conduits shall be of the type permitted under the appropriate electrical codes. **Metal flex conduit is not recommended due to cable abrasion problems and is not covered in this standard.** Fish tape or pull cord/string shall be installed in all conduits.

Any single conduit run extending from a telecommunications terminal closet shall not serve more than three communications outlets. Conduit shall be sized per Table 1.1, below, and be incrementally increased in size from the furthest outlet toward the telecommunications closet. No section of conduit shall be longer than 30 m (100 ft) or contain more than two 90° bends between pull boxes. A third bend may be acceptable in a pull section without derating the conduit's capacity if the run is not longer than 10 m (33 ft) or the conduit size is increased to the next trade size.

TABLE 1.1

CONDUIT		NUMBER OF CABLES									
INTERNAL DIAMETER Mm	TRADE SIZE (in)	WIRE O.D. mm (in)									
		3.3 (.13)	4.6 (.18)	5.6 (.22)	6.1 (.24)	7.4 (.29)	7.9 (.31)	9.4 (.37)	13.5 (.53)	15.8 (.62)	
15.8	0.62	½	1	1	0	0	0	0	0	0	0
20.9	0.82	¾	6	5	4	3	2	2	1	0	0
26.6	1.05	1	8	8	7	6	3	3	2	1	0
35.1	1.38	1 ¼	16	14	12	10	6	4	3	1	1
40.9	1.61	1 ½	20	18	16	15	7	6	4	2	1
52.5	2.07	2	30	26	22	20	14	12	7	4	3
62.7	2.47	2 ½	45	40	36	30	17	14	12	6	3
77.9	3.07	3	70	60	50	40	20	20	17	7	6

Pull Boxes

Pull boxes shall be used for the following purposes:

- a) Fishing the conduit run.
- b) Pulling the cable to the box and then looping the cable to be pulled into the next length of conduit.

Pull boxes shall be placed in an exposed manner and location, and readily accessible. Pull boxes shall not be placed in a fixed, false ceiling space unless immediately above a suitably marked, hinged panel.

A pull box shall be placed in a conduit run where:

- 1) the length is over 30 mm (100 ft);
- 2) there are more than two 90° bends; or,
- 3) if there is a reverse bend in the run.

Boxes shall be placed in a straight section of conduit and not used in lieu of a bend. The corresponding conduit ends should be aligned with each other.

Surface Raceway

Surface raceway, consisting of base, cover, couplings, elbows, and similar fittings, mounts directly on wall surfaces at appropriate work levels to provide a continuous perimeter pathway.

Telecommunications outlets are located in cover fittings along the raceway. The electrical contractor shall provide faceplates for the surface raceway.

The practical capacity for telecommunications wiring in perimeter raceways ranges from 30% to 60% fill depending on cable-bend radius. The pathway size shall be calculated as follows: the summation of the cross-sectional area of all cables divided by the percent (expressed as a decimal fraction) of fill.

Grounding and Bonding

Grounding shall meet the requirements of the NEC and additionally grounding bonding shall conform to ANSI/TIA/EIA-607. When applicable, horizontal cabling and connecting hardware must be grounded and bonded in compliance with ANSI/NFPA 70 requirements and practices. When grounding telecommunications cabling, ensure that the installation conforms with proper practices and codes (ANSI/TIA/EIA-607, ANSI/NFPA 70, and local building codes).

An approved ground is available at the telecommunications terminal closet for:

- Cross-connect frames
- Patch panel racks
- Active telecommunications equipment
- Test apparatus used for maintenance and testing

**Any questions about these standards should be directed to
PSU OIT Telecommunication Systems**

Phone: 503-725-4434 | Email: OIT-TS-Group@pdx.edu

ACCEPTANCE OF CONTRACTOR WORK

PROJECT _____ DATE _____

YES NO

_____ Approved material used.

_____ Labeling of horizontal wire per standards.

_____ Installation of all equipment per standards.

_____ ANSI/EIA/TIA and local codes followed.

_____ Documentation of test results provided for horizontal wire.

_____ Documentation of test results provided for fiber work.

_____ As-builts provided per bid document.

_____ Housekeeping and general clean up.

NOTES:

Appendix 27.2
AV Standards

Portland State University

**Office of Information Technology
Instructional Technology Services**

**Classroom Instructional Technology
Guidelines**

Fall 2014



Portland State
UNIVERSITY

Table of Contents

INTRODUCTION

CLASSROOM INSTRUCTIONAL TECHNOLOGY GUIDELINES

A. Technology Enhanced Classroom

B. Classroom Guidelines

DIGITAL DISPLAY TECHNOLOGY GUIDELINES

VIDEOCONFERENCING/LECTURE CAPTURE GUIDELINES

APPENDIX A – PREFERRED COMPONENT MANUFACTURER PRODUCTS

APPENDIX B – PODIUM WIRING DIAGRAM

APPENDIX C – PODIUM PHOTOS

INTRODUCTION

This document addresses Portland State University (PSU) classroom technology and audio-visual guidelines. The requirements specified address PSU and industry standards for classroom technology. This document will be used by PSU staff, in conjunction with consulting architects, engineers, and designers working for PSU on projects in new or existing facilities requiring the design and installation of audio-visual technology systems. This document and accompanying specifications serve as the core document to ensure uniformity and consistency of any audio-visual technology systems installed on campus. Any exceptions to these guidelines must be reviewed and approved by the Director, OIT-Instructional Technology Services or the OIT Associate CIO on a per project, per location basis.

CONTRACTOR REQUIREMENTS

Installation workmanship shall be of the best quality and executed by professionally qualified, and properly licensed, experienced audio-visual professionals (project managers and installation technicians). These individuals shall be employed and supervised by a competent and experienced audio-visual project manager.

CLASSROOM INSTRUCTIONAL TECHNOLOGY GUIDELINES

All technology enhanced classrooms will meet ITS guidelines and conform to our audio-visual control system and switching equipment standards.

A. Technology Enhanced Classroom

Classrooms will have an instructor's podium that incorporates audio-visual switching and controls that are High-bandwidth Digital Content Protection (HDCP) compliant and include the needed number of inputs and outputs for the required number of sources, program and voice amplification, and outputs to supported devices (projectors or displays) including stereo audio. Output devices (e.g. projectors and digital displays) will be selected based on their appropriateness for the instructional space, based on resolution, projector lumens, and other attributes (e.g. windows, lighting) on the instructional spaces (see Appendix C - Podium Photos). Additional inputs, and outputs should be incorporated into the design, for future growth.

- In all new classrooms there will be either a wall or floor box, conduit pathway, power, six data and ceiling box to support presentation technologies. See Appendix A for Preferred Component /Manufacturer Products
- An installed podium will be placed adjacent to wall or floor box via an umbilical in the classroom, per room owner specifications (in consultation with OIT-ITS).
- Teaching podiums shall have resident technology appropriate for the instructional spaces intended use. Specifically:
 - Resident PC, with Windows 7 OS, keyboard and mouse
 - 16:10 confidence 22" monitor minimum
 - Document camera
 - Blu-ray player, with remote control tethered to podium with 3' of tether, for security
 - Cables managed with panduit cover
 - Ergotron monitor arm
 - Tripp-Lite AC power outlet available at front of podium
 - Rack shelves with T-20 Security Torx screws
 - Option for wired microphone (XLR input)
 - Option to add wireless microphone and transmitter receiver
 - Podium monument with inputs for HDMI, VGA, and composite
 - Podium dimensions should be 30"w x 23 1/4"d x 38 1/8"h minimum and have wheels for mobility
 - Front USB ports connected to the CPU
 - External Video and Stereo inputs
 - Laptop VGA, Audio, and Network inputs with automatic switching
 - Flat panel monitor for presentation and annotation
 - Optional RF wireless keyboard & mouse so the user can move around room
 - Quality wood construction with efficient ventilation
 - Multiple 1.5" minimum grommets for cabling pass thru
 - Keyboard and mouse drawer
 - Reinforced shelves for document camera placement and laptops
 - Easy to operate and network connected control system
 - Microphone inputs with 48v phantom power
 - Cabling provided for connection to projector with available CAT5 solution
 - Back of podium is secured with a lock using OIT-ITS security key
 - "Portland State University" and logo on podium
 - Flexibility to add devices to support and accommodate instructor-owned devices

B. Classroom Technology Construction

Minimum pathway and connectivity requirements for all classroom media construction are as follows. The media conduit pathways will be local to the classroom.

- **Wall Box:** One wall box will be installed in the front corner of the room near the teaching station location. The placement will be a minimum of 5'-6" from each wall to allow for ADA requirements. See Appendix D for Approved Product Manufacturers.

- The wall box will require:
 - One (1) 1" conduit for low voltage video and audio cables
 - One (1) ¾" conduit for dedicated 20 amp 110v electrical cable
 - One (1) 1" conduit for six (6) network data cables
 - the six data ports are for the following:
 - Resident PC
 - Extron HDCP-scaling presentation switcher
 - Extron Global Viewer Enterprise (GVE) connectivity (remote management and controller connection)
 - Auxiliary input on the podium monument for client devices
 - OPTIONAL: Exton TouchPanel
 - OPTIONAL: additional data port for future proofing
- Projector power, data, and signal access location: The audio-visual project manager must confirm the throw distance, aspect ratio, and location for the ceiling box being installed during the design phase for each building with OIT's Instructional Technology Services (ITS).
 - location based on projector throw distance and screen size
 - will be centered with the screen
 - See Media Figure 7 below
- Connectivity between the wall box or floor box and the ceiling location will require one (1) conduit:
 - One (1) 1" conduit for low voltage video and audio cables
 - Conduits will utilize the shortest path within the classroom walls
 - No more than 270 degrees of bend will be accepted
 - See Media Figures 7 and 8 below
- Power: A dedicated 110v 20 amp breaker servicing both the ceiling and wall boxes will be required.
 - One (1) duplex 110v connection will be installed in the ceiling box enclosure
 - One (1) duplex 110v connection will be installed in the floor/wall box at the designated teaching station location
 - Multiple double duplex 110v connections to be installed in various locations for student power needs.
- Data: Four or Six data cables will be routed and terminated in the covered wall/floor box
- Projector Cabling: Media cable connecting the teaching station to the projector will be provided and installed by the contractor. Method of connectivity = cat 6.
- Speakers: Two or more ceiling or wall 8ohm speakers (based on room size and ceiling type) will be provided and installed by the contractor in all rooms. Speakers will be mounted at locations in consult with OIT-ITS in order to produce the best available sound with the elimination of feedback issues and sound reinforcement. A ¾ inch conduit will be installed to connect the speakers. See Appendix A for Preferred Component/Manufacturer Products.
- Screens: Screens will be provided and installed by the contractor, be a minimum of 8 feet wide, and wall mounted. The size of the screen will be determined by the design team with input from OIT-ITS. Viewing angles, screen surface material, and bracket placement should all be taken into consideration in the selection phase. At a minimum all screens will have a controlled screen

return (CSR) mechanism. Screens 10 feet wide or larger should be electric screens with wall controls. All screens must be 16:10 aspect ratio, regardless of size and product dimensions.

- **Physical Security:** All audio-visual equipment in the classroom technology installation must have some form of physical security in place that will ensure that that equipment will not be damaged, lost or stolen in the course of daily use of the classrooms. Security mounts, security screws, locking rack clamps, locking podiums, locking drawers, cabled remote controls are acceptable methods of item security.

DIGITAL DISPLAY TECHNOLOGY GUIDELINES

The size and location of Digital Display screens will be determined by the clients in consultations with OIT-ITS Services.

A. Power Requirements

A single duplex outlet is required to support electronic equipment. Location should be in close proximity to display in consultation with client and Facilities Capital Projects and Construction team.

B. Conduit and Data Outlet

Two Category 6 UTP horizontal cables will be installed from the serving IDF to 6" from power outlet.

C. Wall Support Backing

Wall support backing should be rated for a minimum of 100 lbs to support monitor and mounting bracket. Support backing may need to be increased for 50" or larger monitors. The locations of the power and data outlets need to be coordinated with OIT-ITS, Facilities and Telecom to insure that the screen mount does not conflict with the outlet locations.

D. Digital Display Equipment Selection

- Digital display equipment needs to be commercial grade equipment. Selection of display, mount, control system, media player and/or resident computer for installation must be done in consultation with OIT-ITS Personnel. See Appendix A for Approved Product Manufacturers.

VIDEOCONFERENCING/LECTURE CAPTURE GUIDELINES

PSU's guidelines for video conferencing devices, software, and operating systems must be able to support Google Hangouts or lecture capture hardware device incorporating it into our existing classroom technology podiums. Cameras, microphones and additional equipment needed for video conferencing must be securable.

APPENDIX A – Preferred Component/Manufacturer Products

The following product component/manufacturers meet or exceed the requirements set forth by Portland State University, OIT-ITS.

Component

Manufacturer(s)

Data projectors	Panasonic, Epson
Projector and display mounting hardware	BMS, Chief, Peerless
Fully integrated instructional podiums	Klasstech (Professional, Lectern, Custom built)
AV systems, touch panels, scalers, switchers, room amplification, equipment monitoring	Extron
Document cameras	AverMedia, Elmo, Lumens
Projection screens	Da-Lite
Flat screen displays	Panasonic, LG, Planar
Resident computing equipment	Dell
Speakers	TOA, JBL
Resident microphone technology	Sennheiser
AC power management	Tripp-Lite
Floor boxes	FSR
Ceiling boxes	FSR
Vendor installation	Klasstech, Cochrane, May Technologies, Compview
Projection whiteboards	Da-Lite
Video conferencing systems	AverMedia
Audio-visual equipment racks	Mid-Atlantic
Video production equipment	Panasonic, Vaddio
Lecture capture equipment	Winnov, Extron

APPENDIX B- PODIUM WIRING DIAGRAM

Digital Podium with IN 1608 & Amp

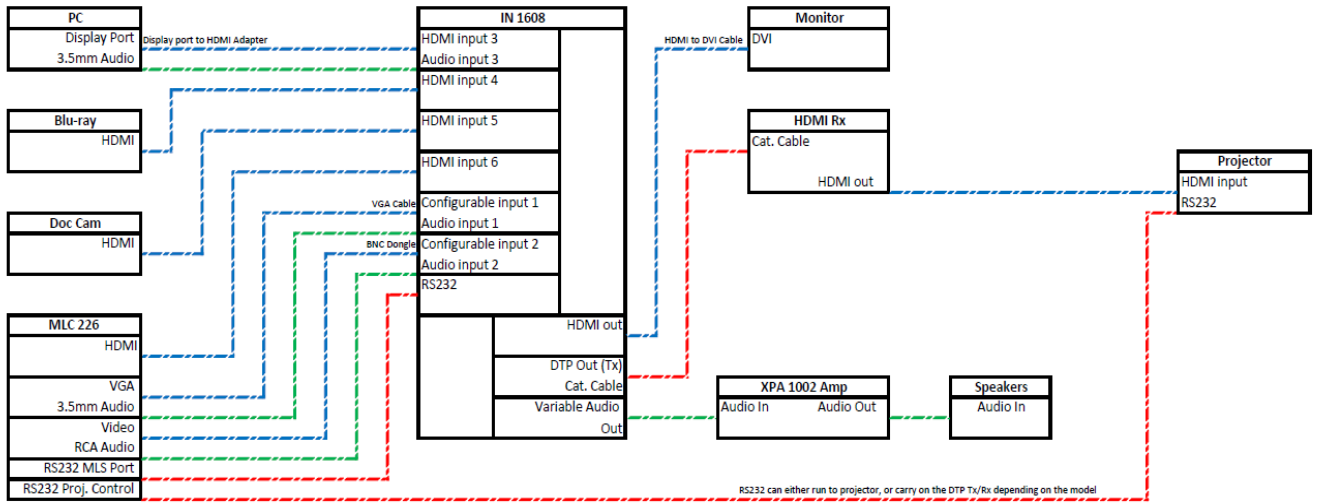

APPENDIX C - PODIUM PHOTOS





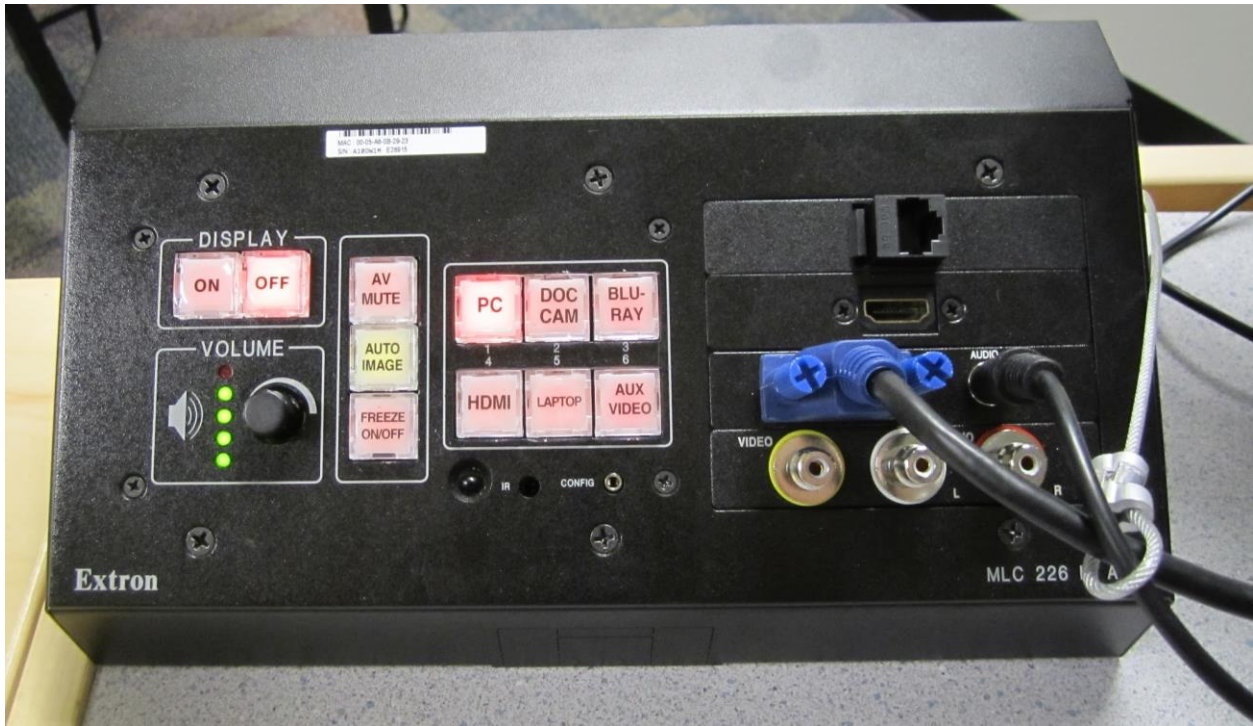







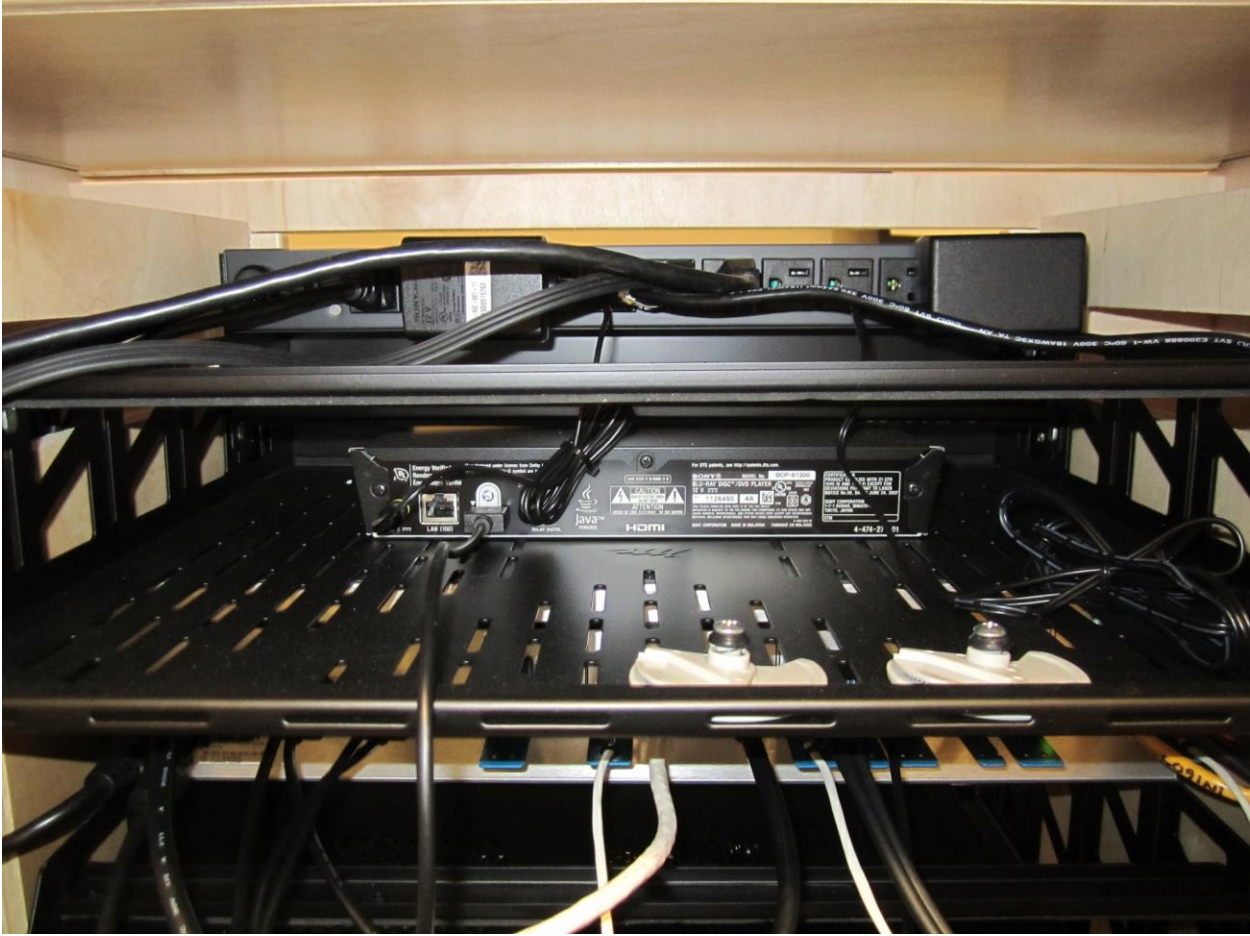



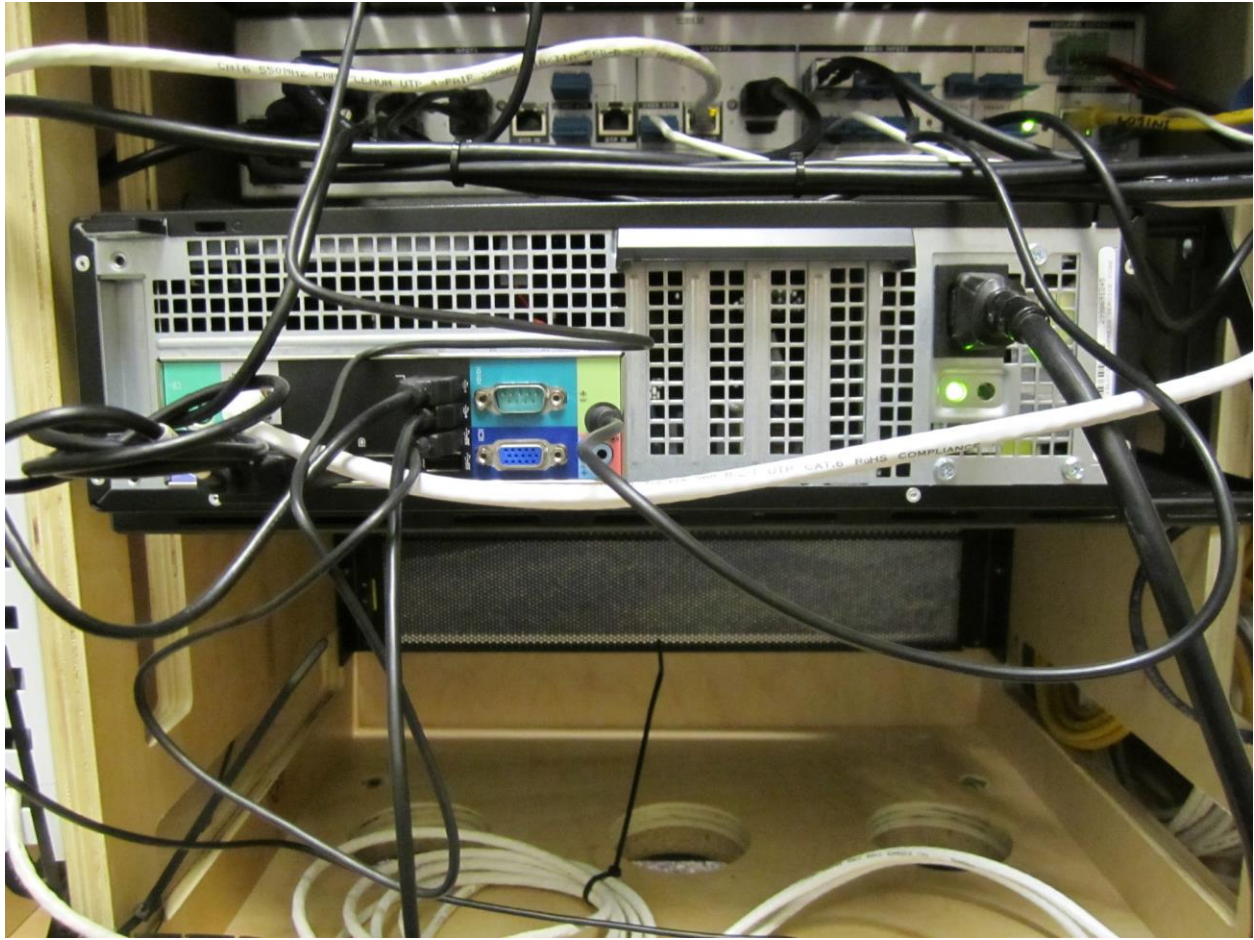

Appendix 28.1

Access Control

PORTLAND STATE UNIVERSITY
DESIGN AND CONSTRUCTION STANDARDS

APPENDIX 28.1 – **ACCESS CONTROL**

PART 1 GENERAL

1.1 STANDARDS OF PERFORMANCE

- A. Contractor to provide, install, and activate access control low voltage cabling and devices.
- B. For all work completed AutoCAD Drawings, Submittals, O&Ms, Warrantee certificates and a copy of any software programs shall be provided upon project closeout.
- C. Contractor to provide complete installation include conduit and boxes for card readers. Fire caulking, patching, and paint is to be provided by contractor to complete installations.
- D. The (6) major access control devices at doors are following:
 - 1. Magnetic swipe or proximity card reader
 - 2. Door contact
 - 3. REX (request to exit motion detector)
 - 4. Sounder
 - 5. Electric lock or electric exit device
 - 6. Power Transfer hinge.
- E. The (4) types of access doors
 - 1. Card Reader Door (items 1-6)
 - 2. Auto lock Door (items 1, 3-6)
 - 3. Exit only Door (items 2,3,4)
 - 4. Emergency Exit only Door (items 2,4)

1.2 RELATED SECTIONS

- A. 08 31 00 Access Doors and Panels

PART 2 PRODUCTS

2.1 CONTROL PANEL

- A. Manufacturer
 - 1. Lenel or approved equal to provide seamless integration with existing systems.
- B. Description
 - 1. Coordinate with PSU Project Manager to identify currently approved model numbers.
 - 2. Strike output relays shall be isolated from the electric locking devices they control.

2.2 LOW VOLTAGE CABELING

- A. Manufacturer
 - 1. Plenum or Approved Equal
- B. Description

PORTLAND STATE UNIVERSITY
DESIGN AND CONSTRUCTION STANDARDS

1. Provide and coordinate all low voltage cabling to all components for a complete working system.

2.3 ENCLOSURES

- A. Manufacturer
 1. Hoffman or approved equal.
- B. Description
 1. Primary central panel enclosures shall be per installation, with cabinet tamper switches.

2.4 CAMERAS

- C. Manufacturer
 1. Sony, Bosch or approved equal.
- D. Description
 1. POE where applicable.
 2. If exterior install, provide heater and blower as required.

2.5 POWER SUPPLIES

- A. Manufacturer
 1. Altronix or approved equal.
- B. Description
 1. None Specified

2.6 BATTERIES

- C. Manufacturer
 1. PSU Approved
- D. Description
 1. Calculations and run time to meet a minimum of 12 hours.

PART 3 EXECUTION

3.1 INSTALLATION

- A. Install per manufacturer's specifications and recommendations.
- B. Contractor to provide record document to include accurate as-built information per PSU requirements.

END OF SECTION