

Chapter 5: Green Infrastructure Practices

This Chapter presents planning and design of green infrastructure practices acceptable for runoff reduction. Green infrastructure planning includes measures for preservation of natural features of the site and reduction of proposed impervious cover. The green infrastructure techniques include practices that enable reductions in the calculated runoff from contributing areas and the required water quality volume.

Section 5.1 Planning for Green Infrastructure: Preservation of Natural Features and Conservation Design

The first step in planning for stormwater management using green infrastructure is to avoid or minimize land disturbance by preserving natural areas. Development should be strategically located based on the location of resource areas and physical conditions at a site. Also, in finalizing construction, soils must be restored to the original properties and according to the intended function of the proposed practices. Preservation of natural features includes techniques to foster the identification and preservation of natural areas that can be used in the protection of water, habitat and vegetative resources. Conservation design includes laying out the elements of a development project in such a way that the site design takes advantage of a site’s natural features, preserves the more sensitive areas and identifies any site constraints and opportunities to prevent or reduce negative effects of development. The techniques covered in this section are listed in Table 5.1.

| Table 5.1 Planning Practices for Preservation of Natural Features and Conservation | |
|---|---|
| Practice | Description |
| Preservation of Undisturbed Areas | Delineate and place into permanent conservation undisturbed forests, native vegetated areas, riparian corridors, wetlands, and natural terrain. |
| Preservation of Buffers | Define, delineate and preserve naturally vegetated buffers along perennial streams, rivers, shorelines and wetlands. |
| Reduction of Clearing and Grading | Limit clearing and grading to the minimum amount needed for roads, driveways, foundations, utilities and stormwater management facilities. |
| Locating Development in Less Sensitive Areas | Avoid sensitive resource areas such as floodplains, steep slopes, erodible soils, wetlands, mature forests and critical habitats by locating development to fit the terrain in areas that will create the least impact. |
| Open Space Design | Use clustering, conservation design or open space design to reduce impervious cover, preserve more open space and protect water resources. |
| Soil Restoration | Restore the original properties and porosity of the soil by deep till and amendment with compost to reduce the generation of runoff and enhance the runoff reduction performance of post construction practices. |

5.1.1 Preservation of Undisturbed Areas

Description: Important natural features and areas such as undisturbed forested and native vegetated areas, natural terrain, riparian corridors, wetlands and other important site features should be delineated and placed into permanent conservation areas.

Key Benefits

- Helps to preserve a site’s natural hydrology and water balance
- Can act as a non-structural stormwater feature to promote additional filtration and infiltration
- Can help to preserve a site’s natural character, habitat and aesthetic appeal
- Has been shown to increase property values for adjacent parcels
- Can reduce structural stormwater management storage requirement and may be used in runoff reduction calculations (see section 5.3)

Figure 5.1 Example of natural resource inventory plan (Source: Georgia Stormwater Manual, 2001)

Typical Perceived Obstacles and Realities

- Preserved conservation areas may limit the development potential of a site – With clustering and other development incentives, development yield can be maintained
- Preserved conservation areas may harbor nuisance wildlife, vegetation, and insects and may present safety hazards - Once established, natural conservation areas must be protected during construction and managed after occupancy by a responsible party able to maintain the areas in a natural state in perpetuity; proper

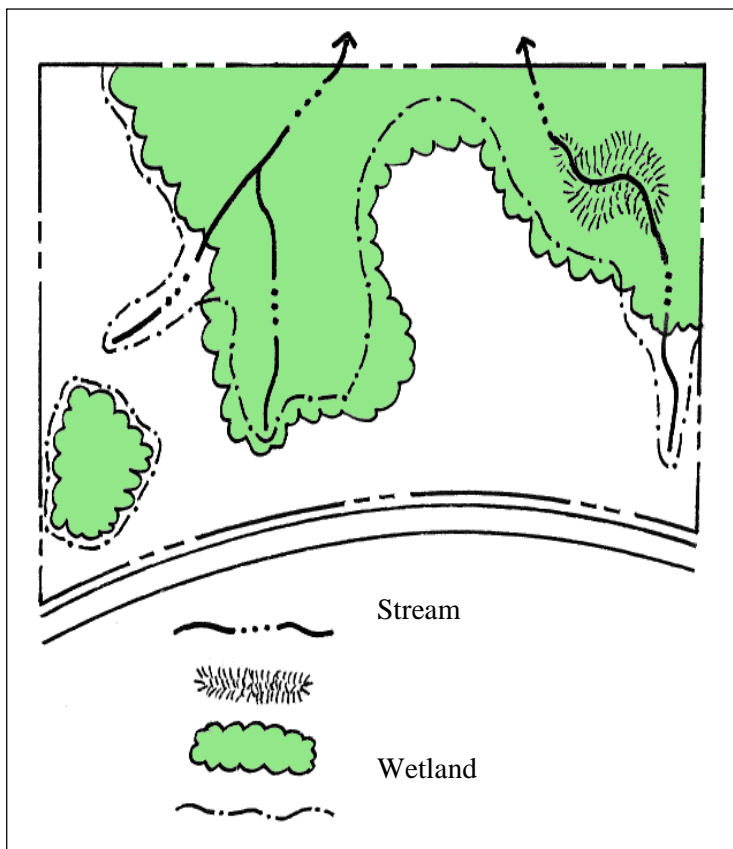

New York State Stormwater Management Design Manual

Chapter 5: Green Infrastructure Practices

Section 5.1 Planning for Green Infrastructure: Preservation of Natural Features and Conservation Design

management and maintenance will address nuisance and safety issues

Using this Practice

- Delineate and define natural conservation areas before performing site layout and design
- Ensure that conservation areas and native vegetation are protected in an undisturbed state through the design, construction and occupancy stages
- Check with the municipality to determine if there are local laws and ordinances that regulate wetlands, stream buffers, forests or habitat protection

Discussion

Conservation of natural areas such as undisturbed forested and native-vegetated areas, natural terrain, riparian corridors and wetlands on a development project can help to preserve pre-development hydrology of the site and aid in reducing stormwater runoff and pollutant load. Previously disturbed and/or managed forest areas may be considered for permanent conservation if they are judged to provide the benefits outlined in this section. Undisturbed vegetated areas also promote soil stabilization and provide for filtering and infiltration of runoff.

Figure 5.2 Aerial photograph of development project illustrating preservation of undisturbed natural areas (Source: Arendt, 1996)



Natural conservation areas are typically identified through a site-analysis stage using mapping and field-reconnaissance assessments. Areas proposed for protection should be delineated early in the planning stage, long before any site design, clearing or construction begins. When done before the concept-plan phase, the planned conservation areas can be used to guide the layout of a project. Figure 5.1 shows components of a natural resources inventory map with proposed conservation areas delineated.

Preservation areas should then be incorporated into site-development plans and clearly marked on all construction and grading plans to ensure that construction activities are kept out of these areas and that native

New York State Stormwater Management Design Manual

Chapter 5: Green Infrastructure Practices

Section 5.1 Planning for Green Infrastructure: Preservation of Natural Features and Conservation Design

vegetation is undisturbed. The boundaries of each conservation area should be mapped by carefully determining the limit which should not be crossed by construction activity.

Once established, natural conservation areas must be protected during construction and managed after occupancy by a responsible party able to maintain the areas in a natural state in perpetuity. Typically, conservation areas are protected by legally enforceable deed restrictions, conservation easements or a maintenance agreement. When one or more of these measures is applied, a permanently protected natural area can be used to reduce the area required for treatment by structural stormwater management measures (see Figure 5.2 for a representative project illustrating natural resource area protection).

5.1.2 Preservation of Buffers

Description: Naturally vegetated buffers should be defined, delineated and preserved along perennial streams, rivers, shorelines and wetlands.

Key Benefits

- Riparian buffers treat stormwater and improve water quality
- Can be used as nonstructural stormwater infiltration zones
- Can keep structures out of the floodplain and provide a right-of-way for large flood events
- Help to preserve riparian ecosystems and habitats
- Can serve as recreational areas
- May be used in runoff reduction calculations if the criteria in this section are met

Typical Perceived Obstacles and Realities

- Buffers may result in a potential loss of developable land – Regulatory tools or other incentives may be available to protect the interests of property owners
- Private landowners may be required to provide public access to privately held stream buffers – Effective buffers can be maintained in private ownership through deed restrictions and conservation easements
- Nuisance wildlife, vegetation, and insects will be present due to the natural buffer area – Once established, vegetated buffers must be protected during construction and managed after occupancy

New York State Stormwater Management Design Manual

Chapter 5: Green Infrastructure Practices

Section 5.1 Planning for Green Infrastructure: Preservation of Natural Features and Conservation Design

by a responsible party able to maintain the areas in a natural state in perpetuity; proper management and maintenance will address nuisance issues

Figure 5.3 Buffer around Rondout Creek, Accord, NY



Using this Practice

- Delineate and preserve naturally vegetated riparian buffers (as well as vegetated buffers along streams listed as intermittent by the Department)
- Define the width, identify the target vegetation, and designate methods to preserve the buffer indefinitely
- Ensure that buffers and native vegetation are protected throughout planning, design, construction and occupancy
- Consult local planning authority for local wetland and/or stream regulations or guidelines for more stringent minimum buffer width

Discussion

A riparian buffer is a special type of natural conservation area along a stream, wetland or shoreline where development is restricted or prohibited. The primary function of buffers is to protect and physically separate a stream, lake, coastal shoreline or wetland from polluted stormwater discharges from future disturbance or encroachment. If properly designed, a buffer can provide stormwater management functions, can act as a right-of-way during floods, and can sustain the integrity of water-resource ecosystems and habitats. An example of a riparian stream buffer is shown in Figure 5.3.

New York State Stormwater Management Design Manual

Chapter 5: Green Infrastructure Practices

Section 5.1 Planning for Green Infrastructure: Preservation of Natural Features and Conservation Design

Forested riparian buffers should be maintained and managed and reforestation should be encouraged where no wooded buffer exists. Proper restoration should include all layers of the forest plant community, including understory, shrubs and groundcover, not just trees. A riparian buffer can be of fixed or variable width but should be continuous and not interrupted by impervious areas that would allow stormwater to concentrate and flow into the stream without first flowing through the buffer.

Ideally, riparian buffers should be sized to include the 100-year floodplain as well as steep banks and freshwater wetlands. The buffer depth needed to perform properly will depend on the size of the stream and the surrounding conditions, but a minimum 25-foot undisturbed vegetative buffer is needed for even the smallest perennial streams, and a 50-foot or larger undisturbed buffer is ideal. Even with a 25-foot undisturbed buffer, additional zones can be added to extend the total buffer to at least 75 feet from the edge of the stream. The three distinct zones within the 75-foot depth are shown in Figure 5.4. The function, vegetative target and allowable uses vary by zone as described in Table 5.2.

These recommendations are minimum standards for most streams. Some streams and watersheds may benefit from additional measures to ensure adequate protection. In some areas, specific state laws or local ordinances already require stricter buffers than are described here. The buffer widths discussed are not intended to modify or supersede wider or more restrictive buffer requirements that are already in place.

As stated above, the streamside or inner zone should consist of a minimum of 25 feet of undisturbed mature forest. In addition to runoff protection, this zone provides bank stabilization as well as shading and protection for the stream. This zone should also include wetlands and any critical habitats, and its width should be

Figure 5. 4: Three-zone stream buffer system (Source: Adapted from Schueler, 1995)

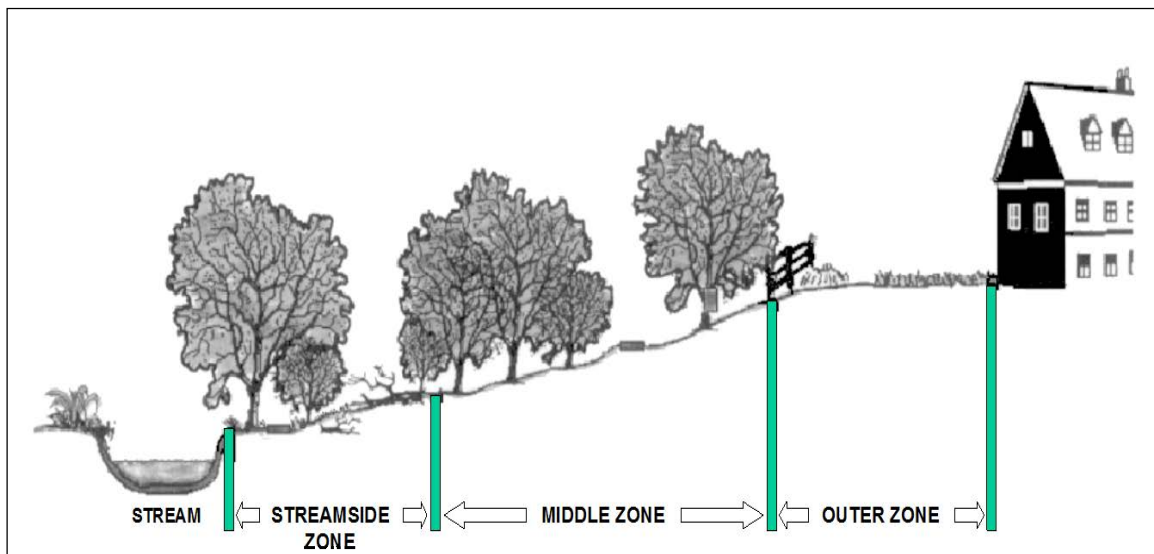

New York State Stormwater Management Design Manual

Chapter 5: Green Infrastructure Practices

Section 5.1 Planning for Green Infrastructure: Preservation of Natural Features and Conservation Design

adjusted accordingly. The middle zone provides a transition between upland development and the inner zone and should consist of managed woodland that allows for infiltration and filtration of runoff. An outer zone allows more clearing and acts as a further setback for impervious surfaces. It also functions to prevent encroachment and filter runoff. It is here that flow into the buffer should be transformed from concentrated flow into sheet flow to maximize ground contact with the runoff.

| | Streamside Zone | Middle Zone | Outer Zone |
|-------------------|--|---|--|
| Width | Minimum 25 feet plus wetlands and critical habitat | Variable, depending on stream order, slope, and 100-year floodplain (min. 25 ft.) | 25-foot minimum setback from structures |
| Vegetative Target | Perennial grasses on steep slopes, undisturbed mature forest. Reforest if necessary. | Managed forest, some clearing allowed | Forest encouraged, but usually turfgrass |
| Allowable Uses | Very restricted (e.g., flood control, utility easements, footpaths) | Restricted (e.g., some recreational uses, some stormwater controls, bike paths) | Unrestricted (e.g., non-structural residential uses, including lawn, garden, most stormwater controls) |

Development within the riparian buffer should be limited only to those structures and facilities that are absolutely necessary. Such limited development should be specifically identified in any codes or ordinances enabling the buffers. When construction activities do occur within the riparian corridor, specific mitigation measures should be required, such as deeper buffers or riparian buffer improvements.

Generally, the riparian buffer should remain in its natural state. However, some maintenance and management are periodically necessary, such as planting to minimize concentrated flow, removal of exotic plant species when these species are detrimental to the vegetated buffer and removal of diseased or damaged trees.

5.1.3 Reduction of Clearing and Grading

New York State Stormwater Management Design Manual

Chapter 5: Green Infrastructure Practices

Section 5.1 Planning for Green Infrastructure: Preservation of Natural Features and Conservation Design

Description: Clearing and grading of the site should be limited to the minimum amount needed for the development function, road access and infrastructure (e.g., utilities, wastewater disposal, stormwater management). Site foot-printing should be used to disturb the smallest possible land area on a site.

Key Benefits

- Preserves more undisturbed natural areas on a development site
- Areas of a site that are conserved in their natural state retain their natural hydrology and do not contribute to construction erosion
- Native trees, shrubs and grasses provide natural landscaping, reducing costs and contributing to the overall quality and viability of the environment.

Typical Perceived Obstacles and Realities

- Preserving trees during construction is expensive – *Minimizing clearing during construction can reduce earth movement and reduce erosion and sediment control costs*
- People prefer large lawns – *Lots with trees may have a higher value than those without*
- Preserved conservation areas may harbor nuisance wildlife, vegetation, and insects and may present safety hazards – *Once established, natural conservation areas must be protected during construction and managed after occupancy by a responsible party to maintain the areas in a natural state in perpetuity; proper management and maintenance will address nuisance and safety issues*

Using this Practice

- Restrict clearing to minimum reqd. for building footprints, construction access, and safety setbacks
- Establish limits of disturbance for all development activities
- Use site foot-printing to minimize clearing and land disturbance
- Avoid mass grading of a site – divide into smaller areas for phased grading
- Use conservation design, open-space or “cluster” developments
- Consult local planning authority for local clearing and grading regulations

Discussion

Minimal disturbance methods should be used to limit the amount of clearing and grading that takes place on a development site, preserving more of the undisturbed vegetation and natural hydrology of a site. A limit of disturbance (LOD) should be established based on the maximum disturbance zone. These maximum

New York State Stormwater Management Design Manual

Chapter 5: Green Infrastructure Practices

Section 5.1 Planning for Green Infrastructure: Preservation of Natural Features and Conservation Design

distances should reflect reasonable construction techniques and equipment needs, together with the physical situation of the development site, such as slopes or soils. LOD distances may vary by type of development, size of lot or site and by the specific development feature involved.

Site "foot-printing" should be used that maps all of the limits of disturbance to identify the smallest possible land area on a site which requires clearing or land disturbance. An example of site foot-printing is illustrated in Figure 5.5. Sites should be designed so that they fit the terrain (see Figure 5.6). During construction, special procedures and equipment that reduce land disturbance should be used. Alternative site designs should be considered to minimize limits of clearing, such as "cluster" developments (see section 5.1.5).

Figure 5.6 Example of site foot-printing (Source: Georgia Stormwater Manual, 2001)



Figure 5.6 Design plan showing limits of clearing (in dark shading) (Source: DDNREC, 1997)

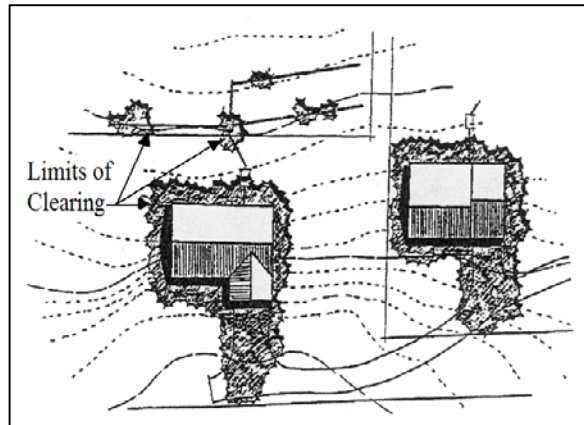

5.1.4 Locating Development in Less Sensitive Areas

Description: Development sites should be located to avoid sensitive resource areas such as floodplains, steep slopes, erodible soils, wetlands, mature forests and critical habitat areas. Buildings, roadways and parking areas should be located to fit the terrain and in areas that will create the least impact.

Key Benefits

- Preserving floodplains provides a natural right-of-way and temporary storage for large flood events; keeps people and structures out of harm's way and helps to preserve riparian ecosystems and habitats

New York State Stormwater Management Design Manual

Chapter 5: Green Infrastructure Practices

Section 5.1 Planning for Green Infrastructure: Preservation of Natural Features and Conservation Design

- Preserving steep slopes and building on flatter areas helps to prevent soil erosion and minimizes stormwater runoff; helps to stabilize hillsides and soils and reduces the need for cut-and-fill and grading
- Avoiding development on erodible soils can prevent sedimentation problems and water-quality degradation. Areas with highly permeable soils can be used as nonstructural stormwater infiltration zones
- Fitting the design to the terrain and in less sensitive areas helps to preserve the natural hydrology and drainageways of a site; reduces the need for grading and land disturbance, and provides a framework for site design and layout

Typical Perceived Obstacles and Realities

- Costs will be higher for developments due to increased planning and design, localized construction and less developable land – *Developments that protect sensitive areas may have higher market value, less liability for potential natural disasters, such as flooding or slope failures and lower construction costs for areas that require less earthwork or difficult terrain, such as steep slopes or wetland areas to work around*

Using this Practice

- Ensure all development activities do not encroach on, fill or alter designated floodplain and/or wetland areas
- Avoid development on steep slope areas and minimize grading and flattening of hills and ridges
- Leave wetlands, floodplains, and areas of porous or highly erodible soils as undisturbed conservation areas
- Develop roadway patterns to fit the site terrain, and locate buildings and impervious surfaces away from steep slopes, drainage ways and floodplains
- Locate sites in areas less sensitive to disturbance or have a lower value in terms of hydrologic function

Discussion

Development in floodplain areas can reduce the ability of the floodplain to convey stormwater, potentially causing safety problems or significant damage to the site in question, as well as to both upstream and downstream properties. The entire 100-year full-buildout floodplain should be avoided for clearing or building activities and should be preserved in a natural, undisturbed state. Where possible, the 500-year

New York State Stormwater Management Design Manual

Chapter 5: Green Infrastructure Practices

Section 5.1 Planning for Green Infrastructure: Preservation of Natural Features and Conservation Design

floodplain should also be preserved in a natural state and/or designated for parks, recreation or agriculture. Development on slopes with a grade of 15% or greater should be avoided, if possible, to limit soil loss, erosion, excessive stormwater runoff and the degradation of surface water. Excessive grading should be avoided on all slopes (Figure 5.7), as should the flattening of hills and ridges. Steep slopes should be kept in an undisturbed natural condition to help stabilize hillsides and soils. On slopes greater than 25%, no development, re-grading, or stripping of vegetation should be considered.

Figure 5.7 Cut and fill grading on steep slopes impacts larger areas than flatter slopes (Source: MPCA, 1989)

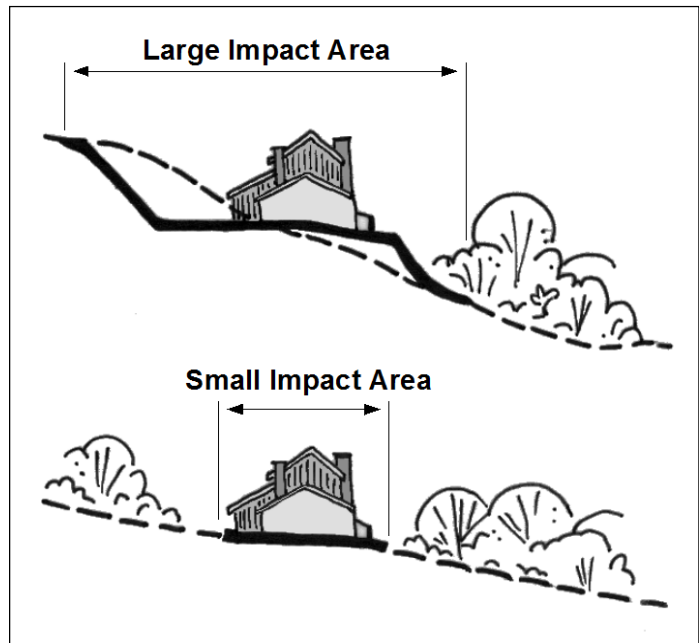

Areas of a site with hydrologic soil group A and B soils, (consult Natural Resources Conservation Service website for hydrological soil groups) such as sands and sandy loam soils, should be conserved as much as possible, and these areas should ideally be incorporated into undisturbed natural or open-space areas (Figure 5.8). Conversely, buildings and other impervious surfaces should be located on

Figure 5.8 Using soil mapping to guide development (Source: Georgia Stormwater Manual, 2001)

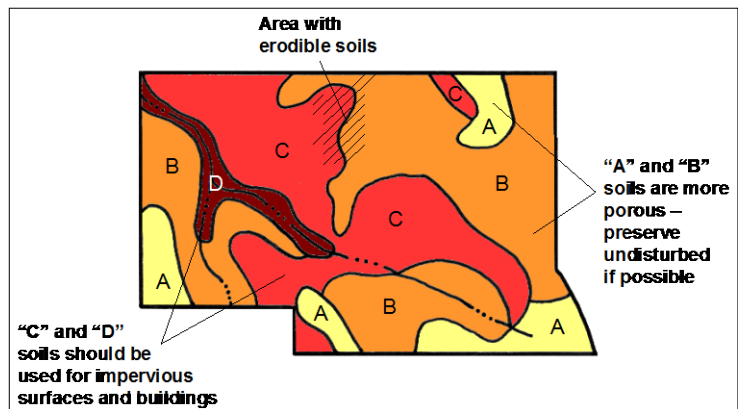

those portions of the site with the *least* permeable soils. Similarly, areas on a site with highly erodible or unstable soils should be avoided for land-disturbing activities and buildings to prevent erosion and sedimentation problems as well as potential structural problems. These areas should be left in an undisturbed and vegetated condition.

New York State Stormwater Management Design Manual

Chapter 5: Green Infrastructure Practices

Section 5.1 Planning for Green Infrastructure: Preservation of Natural Features and Conservation Design

Figure 5.9 Preserving the Natural topography of a Site (Source: Adapted from Prince George's County, 1999)

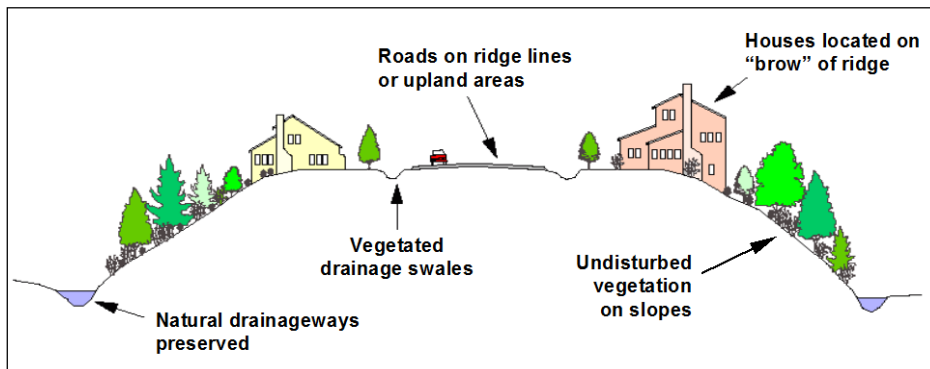

The layout of roadways and buildings on a site should generally conform to the landforms on a site (Figure 5.9). Natural drainage ways and stream buffer areas should be preserved by designing road layouts around them. Buildings should be sited to use the natural grading and drainage system and avoid the unnecessary disturbance of vegetation and soils.

Roadway patterns on a site should be chosen to provide access schemes which match the terrain. In rolling or hilly terrain, streets should be designed to follow natural contours to reduce clearing and grading. In flatter areas, a traditional grid pattern of streets or "fluid" grids which bend and may be interrupted by natural drainage ways may be more appropriate. In much the same way that a development should be designed to conform to the terrain of the site, layout should also be

Figure 5.10 Guiding development to less sensitive site areas (Source: Georgia Stormwater Manual, 2001)

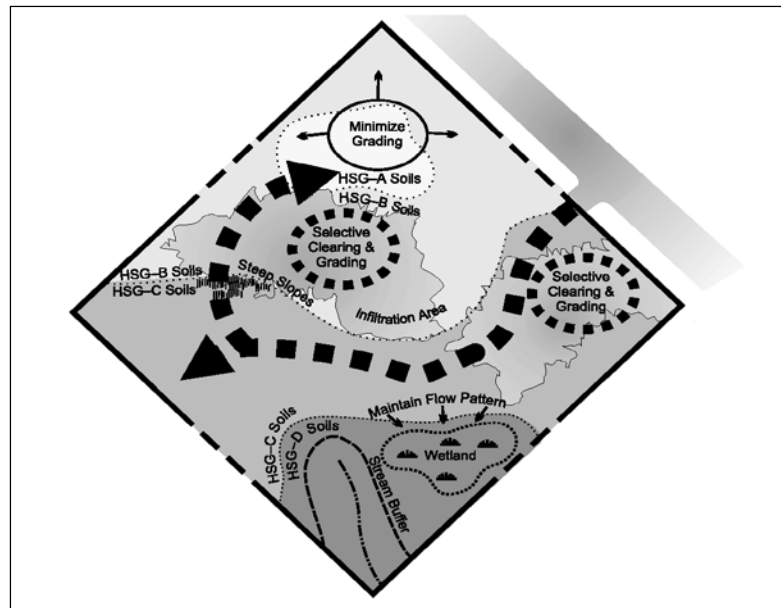

designed so that the areas of development are placed in the locations of the site that minimize the hydrologic impact of the project. This is accomplished by steering development to areas of the site that are less sensitive

New York State Stormwater Management Design Manual

Chapter 5: Green Infrastructure Practices

Section 5.1 Planning for Green Infrastructure: Preservation of Natural Features and Conservation Design

to land disturbance or have a lower value in terms of hydrologic function. Figure 5.10 shows a development site where the natural features have been mapped in order to delineate the hydrologically sensitive areas. Through careful site planning, sensitive areas can be set aside as natural open space areas. In many cases, such areas can be used as buffer spaces between land uses on or between adjacent sites.

5.1.5 Open Space Design

Description: Conservation development, clustering or open space design incorporates smaller lot sizes to reduce overall impervious cover while providing more undisturbed open space and protection of water resources.

Key Benefits

- Preserves conservation areas on a development site
- Can be used to preserve natural hydrology and drainageways
- Can be used to help protect natural conservation areas and other site features
- Reduces the need for grading and land disturbance
- Reduces infrastructure needs and overall development costs
- Allows flexibility to developers to implement creative site designs including better stormwater management practices

Typical Perceived Obstacles and Realities

- Smaller lot sizes and compact development may be perceived by developers as less marketable – *Open space designs can be highly desirable and have economic advantages such as cost savings and higher market appreciation*
- Lack of speed and certainty in the review process may be of concern – *Consult with the local review authority to review requirements; prospective homebuyers may be reluctant to purchase homes due to concerns regarding management of the community open space – Proper methods and implementation of maintenance agreements are available; natural open space reduces maintenance costs and can help keep association fees down*
- Cluster developments appear incompatible with adjacent land uses and are equated with increased noise and traffic – *Open space design allows preservation of natural areas, using less space for*

New York State Stormwater Management Design Manual

Chapter 5: Green Infrastructure Practices

Section 5.1 Planning for Green Infrastructure: Preservation of Natural Features and Conservation Design

streets, sidewalks, parking lots, and driveways; incorporating buffers into the design can help alleviate incompatibility with other competing land uses

Figure 5.11 Aerial view of an open space or “cluster” subdivision (Source: Georgia Stormwater Manual, 2001)



Using this Practice

- Use a site design which concentrates development and preserves open space and natural areas of the site
- Locate the developed portion of the cluster areas in the least sensitive areas of the site
- Consult with the municipality to find out whether there is a local law or ordinance for cluster development, open space design, conservation design or flexible subdivisions
- Where allowed by the municipality, utilize reduced setbacks and frontages, and narrower right-of-way widths to design non-traditional lot layouts within the cluster

Discussion

Conservation development, also known as “open space residential design” (OSRD), or clustering, is a green infrastructure planning technique that concentrates structures and impervious surfaces in a compact area in

Figure 5.12 Open space or “cluster” subdivision example (Source: Georgia Stormwater Manual, 2001)

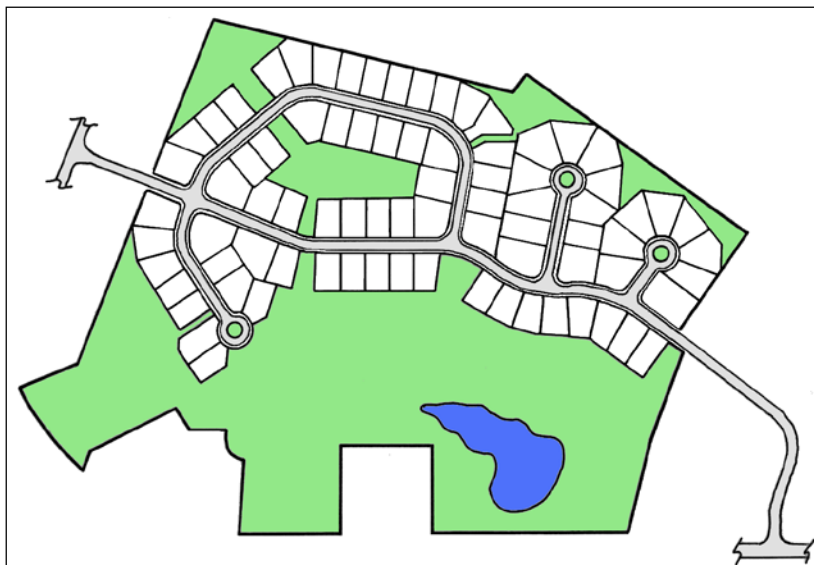

one portion of the development site in exchange for providing open space, natural areas or agricultural lands elsewhere on the site. Typically smaller lots and/or nontraditional lot designs are used to cluster development and create more conservation areas on the site.

Conservation development has many benefits compared with conventional development or residential subdivisions: this technique can reduce impervious

New York State Stormwater Management Design Manual

Chapter 5: Green Infrastructure Practices

Section 5.1 Planning for Green Infrastructure: Preservation of Natural Features and Conservation Design

Figure 5.12 Nontraditional lot design (Source: ULI, 1992)

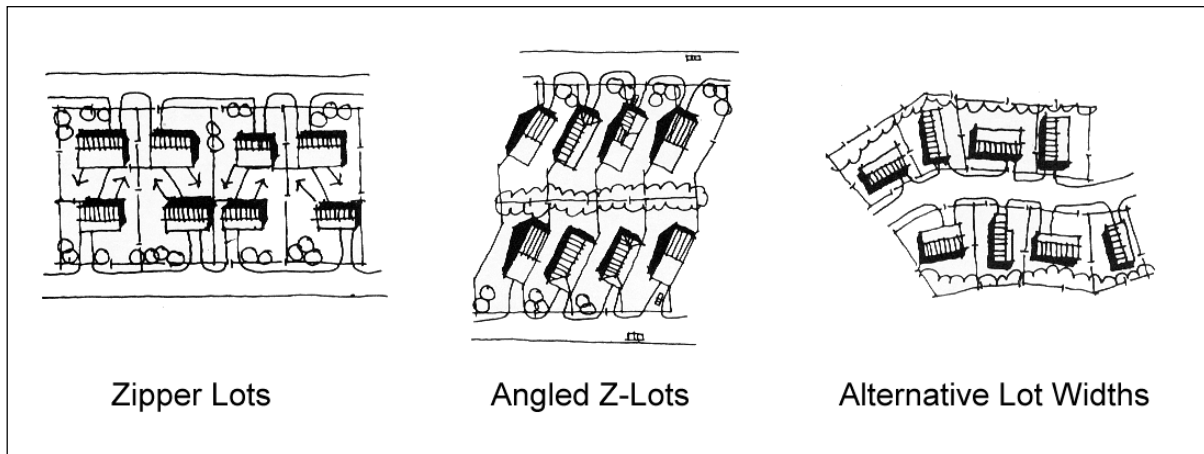

cover, stormwater pollution, construction costs, and the need for grading and landscaping, while providing for the conservation of natural areas. Figures 5.11 and 5.12 show examples of open space developments.

Along with reduced imperviousness, conservation design provides a host of other environmental benefits lacking in most conventional designs. These developments reduce potential pressure to encroach on conservation and buffer areas because enough open space is usually reserved to accommodate these protection areas. As less land is cleared during the construction process, alteration of the natural hydrology and the potential for soil erosion are also greatly diminished. Perhaps most importantly, open space design reserves 25 to 50 percent of the development site in conservation areas that would not otherwise be protected.

Conservation development can also be significantly less expensive to build than conventional projects. Most of the cost savings are due to reduced infrastructure cost for roads and stormwater management controls and conveyances. While conservation developments are frequently less expensive to build, developers find that these properties often command higher prices than those in more conventional developments. Several studies estimate that residential properties in developments with open space garner premiums that are higher than conventional subdivisions and moreover, sell or lease at increased rates. Once established, common open space and natural conservation areas must be managed by a responsible party able to maintain the areas in a natural state in perpetuity. Typically, the conservation areas are protected by legally enforceable deed restrictions, conservation easements, and maintenance agreements. Flexible lot shapes and setback and frontage distances allow site designers to create attractive and unique lots that provide homeowners with enough space while allowing for the preservation of natural areas in a residential subdivision. A narrower Right-of-Way will consume less land that may be better used for housing lots, and allow for a more compact site design. Figures 5.13 and 5.14 illustrate various nontraditional lot designs.

New York State Stormwater Management Design Manual

Chapter 5: Green Infrastructure Practices

Section 5.1 Planning for Green Infrastructure: Preservation of Natural Features and Conservation Design

Figure 5.13 Lots with reduced front and side setbacks



References/Further Resources

- Arendt, Randall. 1994. *Designing Open Space Subdivisions: A Practical Step-by-Step Approach*. Natural Lands Trust, Inc. Media, PA. Available from www.natlands.org or www.greenerprospects.com
- Center for Watershed Protection. 1998. *Better Site Design: A Handbook for Changing Development Rules in Your Community*. Available from www.cwp.org
- Center for Watershed Protection. 1998. *Nutrient Loading from Conventional and Innovative Site Development*. Prepared for: Chesapeake Research Consortium. Center for Watershed Protection, Ellicott City, MD.
- Center for Watershed Protection. 2000. *Maryland Stormwater Manual, 2000* Maryland Department of the Environment. Available from http://www.mde.state.md.us/Programs/WaterPrograms/SedimentandStormwater/stormwater_design/index.asp
- Center for Watershed Protection. 2002. *The Vermont Stormwater Management Manual, Volume I – Stormwater Treatment Standards*. Vermont Agency of Natural Resources. April 2002. Available from: http://www.vtwaterquality.org/stormwater/docs/sw_manual-vol1.pdf
- City of Portland, Oregon. 2004. *Stormwater Management Manual*. Bureau of Environmental Services, Portland, OR. Available from <http://www.portlandonline.com/bes/>
- Flinker, P., H. Dodson, S. la Cour, H. Blanchette, K. Wilson, R Claytor, and N. Kelly. 2005. *The Urban Environmental Design Manual*. Rhode Island Department of Environmental Management, Providence, Rhode Island. Available from <http://www.dem.state.ri.us/programs/bpoladm/suswshed/pubs.htm>
- Harrington, B. W. 1987. *Design Procedures for Stormwater Management Extended Detention Structures*. Maryland Department of the Environment.
- Prince George's County, MD. 1999. *Low-Impact Development Design Strategies: An Integrated Design Approach*. Prince George's County, Maryland, Department of Environmental Resources, Largo, Maryland. Available from www.epa.gov

5.1.6 Soil Restoration

Description

Soil Restoration is a required practice applied across areas of a development site where soils have been disturbed and will be vegetated in order to recover the original properties and porosity of the soil. Healthy soil is vital to a sustainable environment and landscape. A deep, well drained soil, rich in organic matter, absorbs rainwater, helps prevent flooding and soil erosion, filters out water pollutants, and promotes vigorous plant growth that requires less irrigation, pesticides, and fertilizer.

Soil Restoration is applied in the cleanup, restoration, and landscaping phase of construction followed by the permanent establishment of an appropriate, deep-rooted groundcover to help maintain the restored soil structure. Soil restoration includes mechanical decompaction, compost amendment, or both.

Many runoff reduction practices need Soil Restoration measures applied over and adjacent to the practice to achieve runoff reduction performance. (See typical compacted soil in Figure 5.15). Consult individual profile sheets for specific design criteria.

Figure 5.14 Shows typical compacted soils that nearly reach the bulk density of concrete (Schueler et al 2000)



Key Benefits

- More marketable buildings and landscapes
- Less stormwater runoff, better water quality
- Healthier, aesthetically pleasing landscapes
- Increased porosity on redevelopment sites where impervious cover is converted to pervious
- Achieves performance standards on runoff reduction practices
- Decreases runoff volume generated and lowers the demand on runoff control structures
- Enhances direct groundwater recharge
- Promotes successful long-term revegetation by restoring soil organic matter, permeability, drainage and water holding capacity for healthy root system development of trees, shrubs and deep-rooted ground covers, minimizing lawn chemical requirements, plant drowning during wet periods, and burnout during dry periods

Typical Perceived Obstacles and Realities

New York State Stormwater Management Design Manual

Chapter 5: Green Infrastructure Practices

Section 5.1 Planning for Green Infrastructure: Preservation of Natural Features and Conservation Design

- Higher cost due to soil restoration- *application of soil de-compaction and enhancement may have additional initial cost; however, they provide benefit in reducing the need for conveyance structures.*
- Space constraints and obstruction for use of equipment - *post construction space may limit the ability of some of the de-compaction equipment, however, alternative equipment and sensible planning help overcome this obstacle.*

Discussion

Tilling exposes compacted soil devoid of oxygen to air and recreates temporary air space. In addition, research has shown that the incorporation of organic compost, can greatly improve temporary water storage in the soil and subsequent runoff reduction through infiltration and evapotranspiration.

Soils that have a permanent high water table close to the surface (0-12 inches), either influenced by a clay or other highly impervious layer of material, may have bulk densities so naturally high that compaction has little added impact on infiltration (Lacey 2008). However, these soils will still benefit from the addition of compost. The water holding capacity, penetration, structural stability, and fertility of clay soils were improved with compost mixing (Avnimelech and Cohen 1988).

Table 5.3 describes various soil disturbance activities related to land development, soil types and the requirements for soil restoration for each activity. Soil Restoration or modification of curve numbers is a required practice. Restoration is applied across areas of a development site where soils have been compacted and will be vegetated according to the criteria defined in Table 5.3. If Soil Restoration is not applied according to these criteria, designers are required to:

- a) Increase the calculated WQv by factoring in the compacted areas that have not been kept as impervious cover (including areas of cut or fill, heavy traffic areas on site, or Impervious Cover reduction in redevelopment projects unless aeration or full soil restoration is applied, per Table 5.3).
- b) Change by one level the post-construction hydrologic soil group (HSG) to a less permeable group than the original condition. This is applied to all volumetric and discharge rate control computations.

New York State Stormwater Management Design Manual

Chapter 5: Green Infrastructure Practices

Section 5.1 Planning for Green Infrastructure: Preservation of Natural Features and Conservation Design

| Table 5.3 Soil Restoration Requirements | | | |
|---|--|---------------------------------------|---|
| Type of Soil Disturbance | Soil Restoration Requirement | | Comments/Examples |
| No soil disturbance | Restoration not permitted | | Preservation of Natural Features |
| Minimal soil disturbance | Restoration not required | | Clearing and grubbing |
| Areas where topsoil is stripped only - no change in grade | HSG A & B | HSG C&D | Protect area from any ongoing construction activities. |
| | apply 6 inches of topsoil | Aerate* and apply 6 inches of topsoil | |
| Areas of cut or fill | HSG A & B | HSG C & D | |
| | Aerate and apply 6 inches of topsoil | Apply full Soil Restoration ** | |
| Heavy traffic areas on site (especially in a zone 5-25 feet around buildings but not within a 5 foot perimeter around foundation walls) | Apply full Soil Restoration (de-compaction and compost enhancement) | | |
| Areas where Runoff Reduction and/or Infiltration practices are applied | Restoration not required, but may be applied to enhance the reduction specified for appropriate practices. | | Keep construction equipment from crossing these areas. To protect newly installed practice from any ongoing construction activities construct a single phase operation fence area |
| Redevelopment projects | Soil Restoration is required on redevelopment projects in areas where existing impervious area will be converted to pervious area. | | |

*Aeration includes the use of machines such as tractor-drawn implements with coulters making a narrow slit in the soil, a roller with many spikes making indentations in the soil, or prongs which function like a mini-subsoiler.

** Per “Deep Ripping and De-compaction, DEC 2008”.

Using this Practice

During periods of relatively low to moderate subsoil moisture, the disturbed subsoils are returned to rough grade and the following Soil Restoration steps applied:

- 1) Apply 3 inches of compost over subsoil

New York State Stormwater Management Design Manual

Chapter 5: Green Infrastructure Practices

Section 5.1 Planning for Green Infrastructure: Preservation of Natural Features and Conservation Design

- 2) Till compost into subsoil to a depth of at least 12 inches using a cat-mounted ripper, tractor-mounted disc, or tiller, mixing, and circulating air and compost into subsoils
- 3) Rock-pick until uplifted stone/rock materials of four inches and larger size are cleaned off the site
- 4) Apply topsoil to a depth of 6 inches
- 5) Vegetate as required by approved plan.

At the end of the project an inspector should be able to push a 3/8" metal bar 12 inches into the

soil just with body weight. Figures 5.16 and 5.17 show two attachments used for soil decompaction. Tilling (step 2 above) should not be performed within the drip line of any existing trees or over utility installations that are within 24 inches of the surface.

COMPOST SPECIFICATIONS

Compost shall be aged, from plant derived materials, free of viable weed seeds, have no visible free water or dust produced when handling, pass through a half inch screen and have a pH suitable to grow desired plants.

Maintenance

A simple maintenance agreement should identify where Soil Restoration is applied, where newly restored areas are/cannot be cleared, who the responsible parties are to ensure that routine vegetation improvements are made (i.e., thinning, invasive plant removal, etc.). Soil compost amendments within a filter strip or grass channel should be located in public right of way, or within a dedicated stormwater or drainage easement.

First year maintenance operations includes:

- Initial inspections for the first six months (once after each storm greater than half- inch)

Figure 5.15 Soil aerator implement



Figure 5.16 Soil aerator implement



New York State Stormwater Management Design Manual

Chapter 5: Green Infrastructure Practices

Section 5.1 Planning for Green Infrastructure: Preservation of Natural Features and Conservation Design

- Reseeding to repair bare or eroding areas to assure grass stabilization
- Water once every three days for first month, and then provide a half inch of water per week during first year. Irrigation plan may be adjusted according to the rain event.
- Fertilization may be needed in the fall after the first growing season to increase plant vigor
- Ongoing Maintenance:

Two points help ensure lasting results of decompaction:

- 1) Planting the appropriate ground cover with deep roots to maintain the soil structure
- 2) Keeping the site free of vehicular and foot traffic or other weight loads. Consider pedestrian footpaths. (Sometimes it may be necessary to de-thatch the turf every few years)

References/Further Resources

Avnimelech, Y. and M. Kochva, Y. Yotal, D. Shkedy. 1988. *THE USE OF COMPOST AS A SOIL AMENDMENT*

Balusek. 2003. Quantifying decreases in stormwater runoff from deep-tilling, chisel-planting and *compost amendments*. Dane County Land Conservation Department. Madison, Wisconsin.
<http://www.countyofdane.com/lwr/landconservation/papers/quantifyingdecreasesinswrunoff.pdf>

Chollak, T. and P. Rosenfeld. 1998. Guidelines for Landscaping with Compost-Amended Soils City of Redmond Public Works.
<http://www.ci.redmond.wa.us/insidecityhall/publicworks/environment/pdfs/compostamendedsoils.pdf>

City of Portland. 2008. Soil Specification for Vegetated Stormwater Facilities. Portland Stormwater Management Manual. Portland, Oregon

Composting Council (TCC). 1997. Development of a landscape architect specification for *compost utilization*. Alexandria, VA. <http://www.cwc.org/organics/org972rpt.pdf>

DRAFT VA DCR STORMWATER DESIGN SPECIFICATION No. 4, SOIL COMPOST AMENDMENT, VERSION 1.5 June 22, 2009

<http://www.chesapeakestormwater.net/storage/first-draft-baywide-design-specifications/BAYWIDE%20No%204%20SOIL%20AMENDMENT%20SPECIFICATION.pdf>

Holman-Dodds, L. 2004. Chapter 6. Assessing infiltration-based stormwater practices. PhD Dissertation. Department of Hydroscience and Engineering. University of Iowa. Iowa City, IA.

King County Department of Development & Environmental Services, *Achieving the Post-construction Soil Standard*, January 1, 2005. <http://www.metrokc.gov/DDES/forms/1s-inf-SoilPost-ConStd.pdf>

New York State Stormwater Management Design Manual

Chapter 5: Green Infrastructure Practices

Section 5.1 Planning for Green Infrastructure: Preservation of Natural Features and Conservation Design

Lacey, John. 2008. NYSDEC Deep-Ripping and Decompaction , *Guidelines for Infiltration and De-compaction*, New York State Department of Environmental Conservation.

Lenhart, J. 2007. Compost as a soil amendment for water quality treatment facilities. Proceedings 2007 LID Conference. Wilmington, NC

Low Impact Development Center. *Guideline for Soil Amendments*.
<http://www.lowimpactdevelopment.org/epa03/soilamend.htm>

NYS Dept. of Ag & Markets <http://www.agmkt.state.ny.us/AP/agsservices/constructG8.html>

Roa-Espinosa. 2006. An introduction to soil compaction and the subsoiling practice. technical note. Dane County Land Conservation Department. Madison, Wisconsin.

Schueler, T. 2000. “*The Compaction of Urban Soils*” *The Practice of Watershed Protection*. P. 210-214. Center for Watershed Protection

SERAIEG, Southern Extension and Research Activity Information Exchange Group, Interpreting Soil Organic Matter Tests, (2005). http://www.clemson.edu/agrsrvlb/sera6/SERA6-ORGANIC_doc.pdf

Soils for Salmon. 2003. Soil Restoration and compost amendments.
<http://www.soilsforsalmon.org/pdf/SoilsforSalmonLIDrev9-16-04.pdf>

US Composting Council, www.compostingcouncil.org

Section 5.2 Planning for Green Infrastructure: Reduction of Impervious Cover

Once sensitive resource areas and site constraints have been avoided, the next step is to minimize the impact of land alteration by reducing impervious areas. Reduction of impervious cover includes methods to reduce the amount of rooftops, parking lots, roadways, sidewalks and other surfaces that do not allow rainfall to infiltrate into the soil, in order to reduce the volume of stormwater runoff, increase groundwater recharge, and reduce pollutant loadings that are generated from a site. See Table 5.4 for a list of the impervious cover reduction techniques described in the detailed practice sheets in this section.

| Table 5.4 Planning Practices for Reduction of Impervious Cover | |
|---|---|
| Practice | Description |
| Roadway Reduction | Minimize roadway widths and lengths to reduce site impervious area |
| Sidewalk Reduction | Minimize sidewalk lengths and widths to reduce site impervious area |
| Driveway Reduction | Minimize driveway lengths and widths to reduce site impervious area |
| Cul-de-sac Reduction | Minimize the number of cul-de-sacs and incorporate landscaped areas to reduce their impervious cover. |
| Building Footprint Reduction | Reduce the impervious footprint of residences and commercial buildings by using alternate or taller buildings while maintaining the same floor to area ratio. |
| Parking Reduction | Reduce imperviousness on parking lots by eliminating unneeded spaces, providing compact car spaces and efficient parking lanes, minimizing stall dimensions, using porous pavement surfaces in overflow parking areas, and using multi-storied parking decks where appropriate. |

New York State Stormwater Management Design Manual

Chapter 5: Green Infrastructure Practices

Section 5.2 Planning for Green Infrastructure: Reduction of Impervious Cover

5.2.1 Roadway Reduction

Description: Roadway lengths and widths should be minimized on a development site where possible to reduce overall imperviousness.

Key Benefits

- Reduces the amount of impervious cover and associated runoff and pollutants generated
- Reduces the costs associated with road construction and maintenance

Typical Perceived Obstacles and Realities

- Local codes may not permit shorter or narrower roads – *Meet with local officials to discuss waivers for alternative designs that will address concerns of access, snow stockpiling, and parking*
- The public may view narrow roads as unsafe – *Narrower roads in fact reduce the speeds at which vehicles drive; many maintenance and emergency vehicles can in fact access narrow roads*
- Narrow and shorter roads do not have enough parking – *Provisions can be made in the design of a site to accommodate off-street parking*

Using this Practice

- Consider different site and road layouts that reduce overall street length
- Minimize street width by using narrower street designs that are a function of land use, density and traffic demand
- Use smaller side-yard setbacks to reduce total road length
- Consult with local highway and planning officials to determine if narrower roads and smaller setbacks are accepted or whether waivers or variances will be needed

Discussion

The use of alternative road layouts that reduce the total length of roadways can significantly reduce overall imperviousness of a development site. Site designers are encouraged to analyze different site and roadway layouts to see if they can reduce overall street length.

New York State Stormwater Management Design Manual

Chapter 5: Green Infrastructure Practices

Section 5.2 Planning for Green Infrastructure: Reduction of Impervious Cover

Figure 5.17 Potential design options for narrower roadway widths

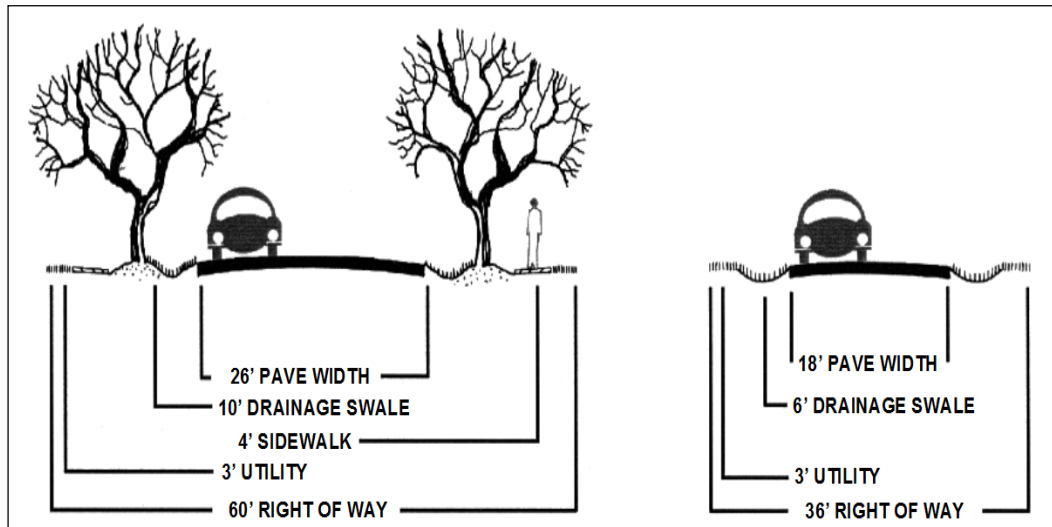

In addition, residential streets and private streets within commercial and other development should be designed for the minimum required pavement width needed to support travel lanes, on-street parking and emergency access. Figure 5.18 shows options for narrower street designs. In many instances, on-street parking can be reduced to one lane or eliminated on local access roads with less than 200 average daily trips (ADT) and on short cul-de-sacs street. One-way, single-lane, loop roads are another way to reduce the width of lower-traffic streets.

County public works and highway departments in New York State as well as the New York State Department of Transportation use the American Association of State Highway Transportation Officials (AASHTO) recommendations for road design. AASHTO recommends that for low volume local roads with less than 400 average daily trips and design speeds of 40 mph or less, the width of the traveled way can be as little as 18 feet. Adding two-foot shoulders on either side, the total would be 22 feet. For larger volume roads, widths would be increased accordingly. See Figure 5.18. Further, reducing side yard setbacks and using narrower frontages can reduce total street length, which is especially important in cluster and open-space designs.

New York State Stormwater Management Design Manual

Chapter 5: Green Infrastructure Practices

Section 5.2 Planning for Green Infrastructure: Reduction of Impervious Cover

Table 5.5 Minimum Width of Traveled Way (Feet) for Specified Design Volume

| Design speed (miles per hour) | Under 400 | 400 to 1500 | 1500 to 2000 | Over 2000 |
|--|-----------|------------------|-----------------|-----------------|
| 15 | 18 | 20 ¹ | 20 | 22 |
| 20 | 18 | 20 ¹ | 22 | 24 ³ |
| 25 | 18 | 20 ¹ | 22 | 24 ³ |
| 30 | 18 | 20 ¹ | 22 | 24 ³ |
| 40 | 18 | 20 ¹ | 22 | 24 ³ |
| 45 | 20 | 22 | 22 | 24 ³ |
| 50 | 20 | 22 | 22 | 24 ³ |
| 55 | 22 | 22 | 24 ³ | 24 ³ |
| 60 | 22 | 22 | 24 ³ | 24 ³ |
| Width of graded shoulder on each side of road (feet) | | | | |
| All speeds | 2 | 5 ^{1,2} | 6 | 8 |

¹ For roads in mountainous terrain with design volume of 400 to 600 vehicles/day, use 18-foot traveled way width and 2-foot shoulder width.

² May be adjusted to achieve a minimum roadway width of 30 feet for design speeds greater than 40 mph.

³ Where the width of the traveled way is shown as 24 feet, the width may remain at 22 feet on reconstructed highways where alignment and safety records are satisfactory.

From: A Policy on Geometric Design of Highways and Streets, (Exhibit 5-5. Minimum Width of Traveled Way and Shoulders) 2004, by the American Association of State Highway and Transportation Officials, Washington, D.C. Used by permission.

New York State Stormwater Management Design Manual

Chapter 5: Green Infrastructure Practices

Section 5.2 Planning for Green Infrastructure: Reduction of Impervious Cover

5.2.2 Sidewalk Reduction

Description: Sidewalk lengths and widths should be minimized on a development site where possible to reduce overall imperviousness.

Key Benefits

- Reduces the amount of impervious cover and associated runoff and pollutants generated
- Reduces the costs associated with construction and maintenance
- Reduces the individual homeowner's responsibility for maintenance, such as snow clearance

Typical Perceived Obstacles and Realities

- Sidewalks on only one side of the street may be perceived as unsafe – *Accident research shows sidewalks on one side are nearly as safe as sidewalks on both*
- Homebuyers are perceived to want sidewalks on both sides – *Some actually prefer not to have a sidewalk in front of their home, and there is no market difference between homes with and without sidewalks directly in front.*
- Local codes may not permit narrower, alternative, or the elimination of a sidewalk – *Meet with local officials to discuss waivers for alternative designs that will address concerns of accessibility and safety issues.*

Using this Practice

- Locate sidewalks on only one side of the street where applicable (may not apply in downtown and village areas where walkability is important)
- Provide common walkways linking pedestrian areas
- Use alternative sidewalk and walkway surfaces
- Shorten front setbacks to reduce walkway lengths
- Consult with local highway and planning officials to determine if alternative sidewalk designs and paving materials are allowed or whether waivers or variances will be needed

Discussion

Most local codes require that sidewalks be placed on both sides of residential streets (e.g., double sidewalks) and be constructed of impervious concrete or asphalt. For state and federally-funded projects, the standard width of a sidewalk is 5 feet. Many subdivision codes also require sidewalks to be 4 to 6 feet wide and 2 to 10 feet from the street. These codes are enforced to provide sidewalks as a safety measure.

New York State Stormwater Management Design Manual

Chapter 5: Green Infrastructure Practices

Section 5.2 Planning for Green Infrastructure: Reduction of Impervious Cover

Developers may wish to consider allowing sidewalks on only one side of the street or eliminating them where they don't make sense. Sidewalks should be designed with the goal of improving pedestrian movement and diverting it away from the street. Developers may also consider reducing sidewalk widths and placing them farther from the street. In addition, sidewalks should be graded to drain to front yards rather than the street, or planters could be used as filters placed between sidewalk and road.

Alternative surfaces for sidewalks and walkways should be considered to reduce impervious cover (Figure 5.19). In addition, building and home setbacks should be shortened to reduce the amount of impervious cover from entry walks.

Figure 5.18 Sidewalk with common walkways linking pedestrian areas (Source: MA EOE, 2005)



5.2.3 Driveway Reduction

Description: Driveway lengths and widths should be minimized on a development site where possible to reduce overall imperviousness.

Key Benefits

- Reduces the amount of impervious cover and associated runoff and pollutants generated

Typical Perceived Obstacles and Realities

- Alternative driveway surfaces make snow removal more difficult – *Careful site design, material selection and homeowner education can help alleviate the concern*
- Developers perceive alternative surfaces as less marketable – *“Green” development projects are increasingly being sought by consumer.*
- Homeowners have concerns regarding access with shared driveways – *Proper site design, shared driveway agreements¹ and homeowner education will alleviate access issues*
- Local codes may not permit shorter or narrower driveways or driveways with porous surfaces – *Meet with local officials to discuss waivers for alternative designs*

Figure 5.19 Reduced driveway lengths by using shared driveways (Source: MA EOE, 2005)



Using this Practice

- Use shared driveways that connect two or more homes
- Use alternative driveway surfaces

¹ For a model shared driveway agreement see, "Town of Clinton: Recommended Model Development Principles for Conservation of Natural Resources in the Hudson River Estuary Watershed; Appendix 2," 2006 at <http://www.townofclinton.com/pdf/ClintonBSDrev8.pdf>

New York State Stormwater Management Design Manual

Chapter 5: Green Infrastructure Practices

Section 5.2 Planning for Green Infrastructure: Reduction of Impervious Cover

- Use smaller lot front building setbacks to reduce total driveway length
- Use shared driveway agreements for maintenance
- Consult with local highway and planning officials to determine if alternative driveway designs and paving materials are allowed or whether waivers or variances will be needed

Figure 5.20 Permeable pavers as an alternative driveway surface



Discussion

Most local subdivision codes are not very explicit as to how driveways must be designed. Most simply require a standard apron to connect the street to the driveway but don't specify width or surface material. Typical residential driveways range from 12 feet wide for one-car driveways to 20 feet for two. While shared driveways are discouraged or prohibited by many communities, they can reduce impervious cover and should be encouraged with enforceable maintenance agreements and easements (Figure 5.20).

The typical 400-800 square feet of impervious cover per driveway can be minimized by using narrower driveway widths, reducing the length of driveways, or using alternative surfaces such as double-tracks, reinforced grass or permeable paving materials (Figure 5.21).

Building and home setbacks should be shortened to reduce the amount of impervious cover from driveways and entry walks. A setback of 20 feet is more than sufficient to allow a car to park in a driveway without encroaching into the public right of way and reduces driveway and walk pavement by more than 30 percent compared with a setback of 30 feet (see Figure 5.22).

Figure 5.21 Reduced driveway and walkway lengths by using reduced setbacks (Adapted from: MPCA, 1989)

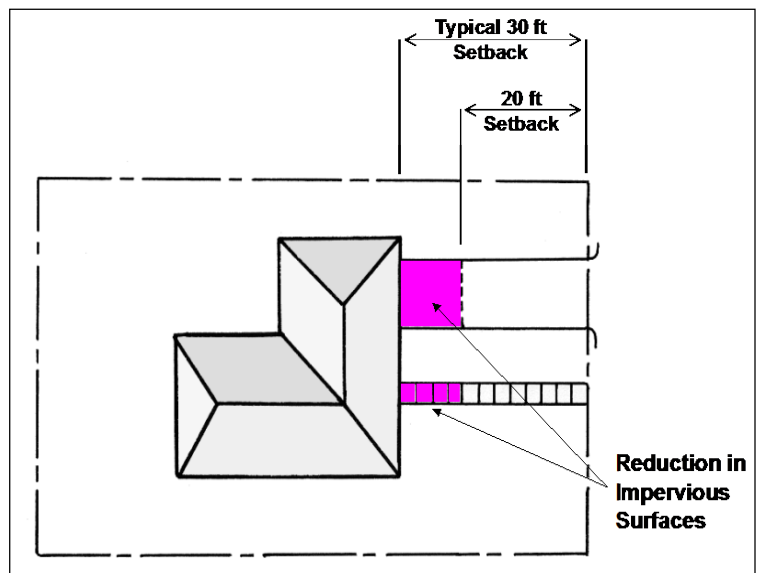

5.2.4 Cul-de-sac Reduction

Description: Minimize the number of cul-de-sacs and incorporate landscaped areas to reduce their impervious cover. The radius of a cul-de-sac should be the minimum required to accommodate emergency and maintenance vehicles. Alternative turnarounds should also be considered.

Key Benefits

- Reduces the amount of impervious cover, associated runoff and pollutants generated
- Increases aesthetics by allowing for natural or landscaped areas rather than pavement

Typical Perceived Obstacles and Realities

- Emergency and maintenance vehicles require a large turning radius – *Many newer vehicles are available with small turning radii*
- School buses require a large turning radius - *Verify school bus pick-up plans. Not every cul-de-sac will need to accommodate school bus turning radii*
- Homeowners like the “end of the road” appeal of cul-de-sacs – *This appeal can be accommodated using loop roads or lots that back onto open space areas*
- Local codes may not permit smaller or alternative cul-de-sac designs – *Meet with local officials to discuss waivers for alternative designs that will address concerns of access*

Using this Practice

- Reduce the radius of the turnaround bulb or consider alternative cul-de-sac design, such as “tee” turn-a-rounds or looping lanes
- Apply site design strategies that minimize dead-end streets
- Create a pervious island or a stormwater bioretention area in the cul-de-sac center to reduce impervious area
- Consult with local highway and planning officials to determine if alternative cul-de-sac designs are allowed or whether waivers or variances will be needed

Discussion

Alternative turnarounds are end of the street designs that replace fully-paved cul-de-sacs and reduce the amount of impervious cover created in developments. Cul-de-sacs are local access streets with a closed circular end that allows for vehicle turnarounds. Many of these cul-de-sacs can have a radius of more than 40 feet. From a stormwater perspective, cul-de-sacs create a huge bulb of impervious cover, increasing the

New York State Stormwater Management Design Manual

Chapter 5: Green Infrastructure Practices

Section 5.2 Planning for Green Infrastructure: Reduction of Impervious Cover

amount of runoff. For this reason, reducing the size of cul-de-sacs through the use of alternative turnarounds or eliminating them altogether can reduce the amount of impervious cover created at a site.

Numerous alternatives create less impervious cover than the traditional 40-foot cul-de-sac. These alternatives include reducing cul-de-sacs to a 30-foot radius and creating hammerheads, loop roads and pervious islands in the cul-de-sac center (see Figures 5.23, 5.24 and 5.25 below).

Sufficient turnaround area is a significant factor to consider in the design of cul-de-sacs. In particular, the types of vehicles entering the cul-de-sac should be considered. Fire trucks, service vehicles and school buses are often cited as needing large turning radii. However, some fire trucks are designed for smaller turning radii. In addition, many newer large service vehicles are designed with a tri-axle (requiring a smaller turning radius), and many school buses usually do not enter individual cul-de-sacs.

Figure 5.23 T-shaped turnaround option
(Source: Center for Watershed Protection, 2005)



Figure 5.23 Loop road option (Source: Center for Watershed Protection, 2005)



Another option for designing cul-de-sacs involves the placement of a pervious island in the center. Vehicles only travel along the outside of the cul-de-sac when turning, leaving an unused “island” of pavement in the center. These islands can be attractively landscaped and also designed as bioretention areas to treat stormwater (see section 6.4 of this Manual).

The most recent AASHTO guidelines should be used for cul-de-sac and alternative turnaround designs, and the design should create no more impervious surface than specified in the AASHTO guidelines.

New York State Stormwater Management Design Manual

Chapter 5: Green Infrastructure Practices

Section 5.2 Planning for Green Infrastructure: Reduction of Impervious Cover

Figure 5.24 Types of cul-de-sacs and dead-end streets

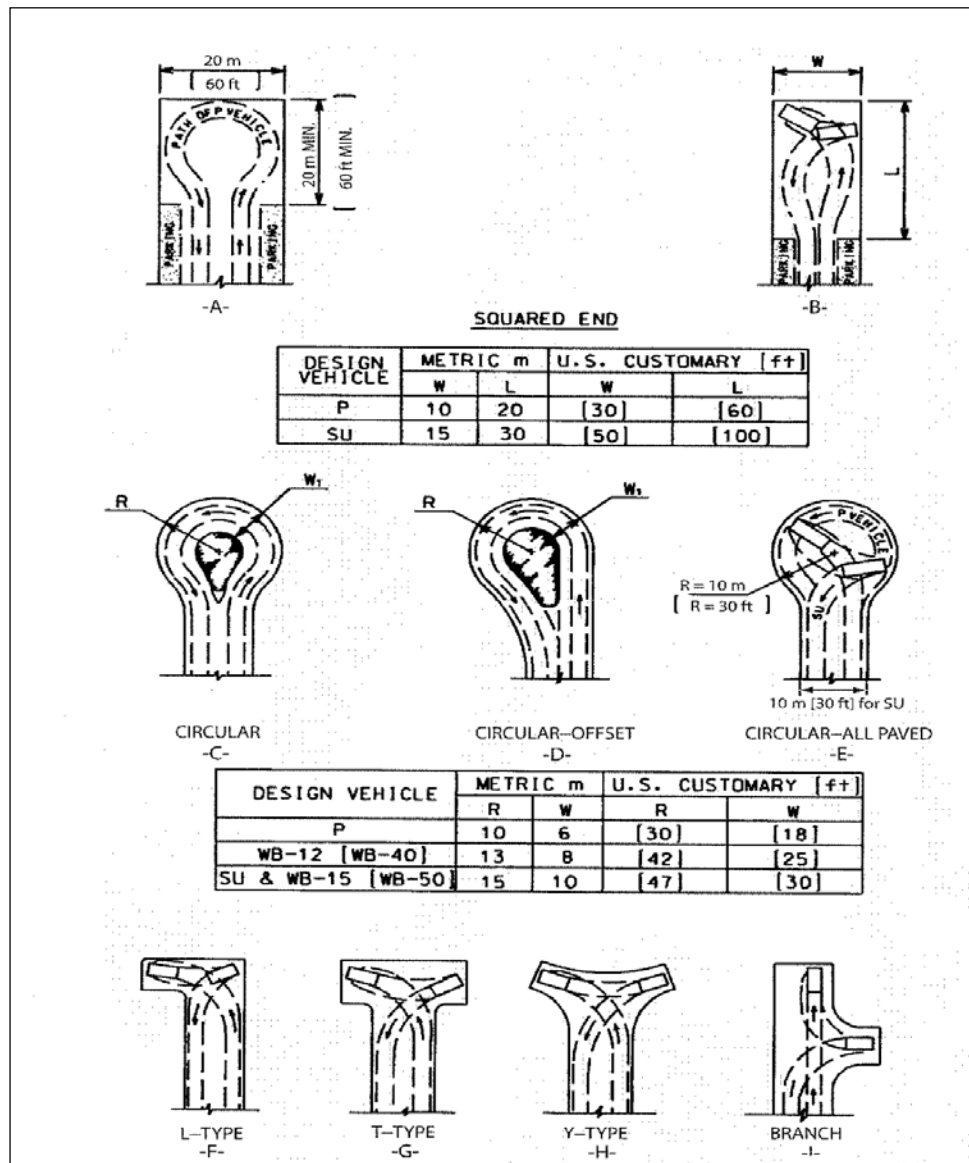

From: A Policy on Geometric Design of Highways and Streets, 2004, by the American Association of State Highway and Transportation Officials, Washington, D.C. Used by permission.

P = Passenger Car

SU = Single-Unit Truck

WB = Wheel Base - applies to semitrailer

New York State Stormwater Management Design Manual

Chapter 5: Green Infrastructure Practices

Section 5.2 Planning for Green Infrastructure: Reduction of Impervious Cover

5.2.5 Building Footprint Reduction

Description: The impervious footprint of residences and commercial buildings can be reduced by using alternate or taller buildings while maintaining the same floor-to-area ratio.

Key Benefits

- Reduces the amount of impervious cover and associated runoff and pollutants generated

Typical Perceived Obstacles and Realities

- Taller buildings are perceived to have higher construction and maintenance costs – *Costs for taller buildings and associated parking may be offset by reduced land and construction and maintenance costs*
- Local codes may not permit taller buildings – *Consider alternative locations that do allow taller buildings, or meet with local officials to discuss waivers for alternative designs*

Using this Practice

- Use alternate or taller building designs to reduce the impervious footprint of buildings.
- Consolidate functions and buildings or segment facilities to reduce footprints of structures.
- Reduce directly connected impervious areas.
- Consult with local planning officials to determine allowed building heights and whether variances will be needed for alternative designs.

Discussion

In order to reduce the imperviousness associated with the footprint and rooftops of buildings and other structures, alternative and/or vertical (taller) building designs should be considered. Consolidate functions and buildings, as required, or segment facilities to reduce the footprint of individual structures. Figure 5.26 shows the reduction in impervious footprint by using a taller building design, and Figures 5.27 and 5.28 show residential examples of reduced footprints.

New York State Stormwater Management Design Manual

Chapter 5: Green Infrastructure Practices

Section 5.2 Planning for Green Infrastructure: Reduction of Impervious Cover

Figure 5.25 Reduction of impervious cover by building up rather than out

(Source: Georgia Stormwater Manual, 2001)

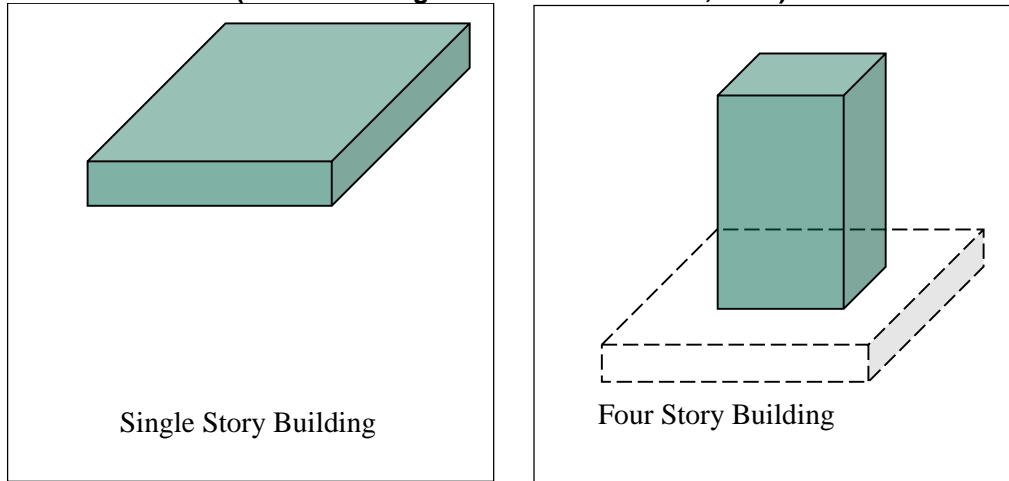

Figure 5.27 Taller houses create a smaller impervious footprint (Source: Center for Watershed Protection, 2005)



Figure 5.27 Taller apartments create a smaller impervious footprint (Source: City of Portland, OR, 2001)



5.2.6 Parking Area Reduction

Description: Reduce the overall imperviousness associated with parking lots by eliminating unneeded spaces, providing compact car spaces, minimizing stall dimensions, incorporating efficient parking lanes, using multi-storied parking decks and using porous paver surfaces or porous concrete in overflow parking areas where feasible.

Key Benefits

- Reduces the amount of impervious cover, associated runoff and pollutants generated
- Reduces construction costs, long-term operation and maintenance costs, and the need for larger stormwater facilities
- Improves aesthetics of an area by increasing vegetative surfaces and reducing the feeling of a large, paved urban area

Typical Perceived Obstacles and Realities

- Developers desire excess parking and fear losing customers during peaks – *Potential loss of customers due to reduced parking is unknown however, often times parking areas are not full during peak periods*
- Parking may spill over into residential or commercial areas when full – *Include preferential parking provisions for residents or parking enforcement with meters*
- Trend to larger vehicles such as SUVs – *Stall width requirements in most local parking codes are much larger than the widest SUVs*
- Structured parking is more expensive than surface lots – *Costs for structured parking may be offset by land costs or by constructing garages above or below an actual building*
- Porous pavement surfaces are more expensive to install and maintain – *Alternative surfaces may reduce the need for deicing treatments as well as alleviate the need for larger stormwater treatment elsewhere on the site*

Using this Practice

- Reduce the number of unnecessary parking spaces by examining minimum parking ratio requirements, and set a maximum number of spaces
- Reduce the number of un-needed parking spaces by examining the site's accessibility to mass transit
- Minimize individual parking stall dimensions, consulting local codes to determine if a waiver or variance is required

New York State Stormwater Management Design Manual

Chapter 5: Green Infrastructure Practices

Section 5.2 Planning for Green Infrastructure: Reduction of Impervious Cover

- Examine the traffic flow of the parking lot design to eliminate un-needed lanes / drive aisles
- Consider parking structures and shared parking arrangements between non-competing uses
- Use alternative porous surface for overflow areas or main parking areas if not a high-traffic parking lot
- Use landscaping or vegetated stormwater practices in parking lot islands
- Provide incentives for compact and hybrid cars

Discussion

Setting maximums for parking spaces, minimizing stall dimensions, using structured parking, encouraging shared parking, using alternative porous surfaces can all reduce parking footprint and site imperviousness. Some Planning Boards require that only a portion of the minimum parking spaces be constructed, and that space be provided to construct the remaining required spaces if needed.

Table 5.4: Conventional Minimum Parking Ratios
(Source: CWP, 1998; modified NYSDEC, 2010)

| Land Use | Parking Requirement | | | Actual Average Parking Demand |
|-----------------------|---|---------------|---|-----------------------------------|
| | Parking Ratio | Typical Range | New York Example* | |
| Single family homes | 2 spaces per dwelling unit | 1.5–2.5 | 2 spaces per dwelling unit, plus 1 per auxiliary unit | 1.11 spaces per dwelling unit |
| Shopping center | 5 spaces per 1000 ft ² GFA | 4.0–6.5 | 5.5 for > 2000 ft ² Net Floor Area | 3.97 per 1000 ft ² GFA |
| Convenience store | 3.3 spaces per 1000 ft ² GFA | 2.0–10.0 | 7 per for < 2000 ft ² Net Floor Area | -- |
| Industrial | 1 space per 1000 ft ² GFA | 0.5–2.0 | 1 space per employee | 1.48 per 1000 ft ² GFA |
| Medical/dental office | 5.7 spaces per 1000 ft ² GFA | 4.5–10.0 | 6.7 per 1000 ft ² of net floor area | 4.11 per 1000 ft ² GFA |

GFA = Gross floor area of a building without storage or utility spaces,

*Town of Amherst Zoning Ordinance, net floor area is 0.75 to 0.9 of GFA, allows

for alternate parking plans (<http://www.amherst.ny.us/pdf/planning/compplan/zcrc/p7.pdf>)

New York State Stormwater Management Design Manual

Chapter 5: Green Infrastructure Practices

Section 5.2 Planning for Green Infrastructure: Reduction of Impervious Cover

Many parking lot designs result in far more spaces than actually required. This problem is exacerbated by a common practice of setting parking ratios to accommodate the highest hourly parking during the peak season. By determining average parking demand instead, a lower maximum number of parking spaces can be set to accommodate most of the demand. Table 5.6 provides examples of conventional parking requirements and compares them to average parking demand. In addition, the number of parking spaces needed may be reduced by a site's accessibility to public transportation.

Figure 5.28 Structured parking at an office park
(Source: Georgia Stormwater Manual, 2001)



Another technique to reduce the parking footprint is to minimize the dimensions of the parking spaces. This can be accomplished by reducing both the length and width of the parking stall. Parking stall dimensions can be further reduced if compact spaces are provided. Another method to reduce the parking area is to incorporate efficient parking lanes such as using one-way drive aisles with angled parking rather than the traditional two-way aisles.

Structured parking decks are another method for significantly reducing the overall parking footprint by minimizing surface parking. Figure 5.29 shows a parking deck used for a commercial development.

Shared parking in mixed-use areas and structured parking are techniques that can further reduce the conversion of land to impervious cover. A shared parking arrangement could include usage of the same parking lot by an office space that experiences peak parking demand during the weekday with a church that experiences parking demands during the weekends and evenings. Provide a written agreement for the parties to sign that specifies usage and maintenance.

Using alternative surfaces such as porous pavers or porous concrete is an effective way to reduce the amount of runoff generated by parking lots. They can replace conventional asphalt or concrete in both new

New York State Stormwater Management Design Manual

Chapter 5: Green Infrastructure Practices

Section 5.2 Planning for Green Infrastructure: Reduction of Impervious Cover

developments and redevelopment projects. Figure 5.30 is an example of porous pavers used at an overflow lot. Alternative pavers can also capture and treat runoff from other areas on the site.

When possible, expanses of parking should be broken up with landscaped islands at or below the grade of the parking area, with islands could include (see Figure 5.31) or management “islands” swales and bioretention snow removal, should not include end 5.3.2, 5.3.4, 5.3.3, 6.4

Figure 5.30 Expanses of parking area “Broken-Up” with Landscape Features



curb cuts. These shade trees and shrubs landscaped stormwater such as filter strips, areas. To facilitate landscaped islands of Trees. (see sections and 6.5 of this Manual).

Figure 5.29 Grass pavers for parking (Source: Georgia Stormwater Manual, 2001)



New York State Stormwater Management Design Manual

Chapter 5: Green Infrastructure Practices

Section 5.3 Green Infrastructure Techniques

Section 5.3 Green Infrastructure Techniques

Runoff Reduction is best achieved through the reduction of the effective impervious surface area of the catchment and minimization of disturbed area. This is particularly the case where pre-development soils demonstrate significant infiltration capacity. This section presents a series of green infrastructure principles and practices that can be incorporated in the site design to allow for micro management of runoff, promote groundwater recharge, increase losses through evapotranspiration and emulate the preconstruction hydrology, resulting in reduced water-quality-treatment volume.

Green infrastructure techniques utilize the natural features of the site and promote runoff reduction. By using these principles, the techniques in this Chapter provide an opportunity for distributed runoff control from individual sources, flow routing, infiltration, treatment and reduction of total water quality volume. Acceptable green infrastructure techniques are explained in this section of this Manual. A profile sheet for each practice provides associated description, performance criteria, design detail, sizing criteria, application, benefits, and limitations. The profile sheets identify the Required Elements of the design. Deviation from these requirements must be documented and justified.

The computation runoff reduction fall under two general methods. The first group of practices includes site design techniques that a designer could factor in by subtracting conserved areas from the total site area, resulting in reduced WQv and CPv. The second group of green infrastructure practices provides runoff reduction by storage of volume runoff and are computed accordingly. The following basic principles must be applied to all green infrastructure design applications:

- Each green infrastructure technique must be appropriately sized for its contributing drainage area.
- Contributing drainage areas, depending on final grading, flow path, impervious cover disconnection, and varying levels of micro management of the flow, may require sub-catchment delineation.
- For all green infrastructure techniques that involve infiltration, soil infiltration testing is required. Testing must be performed at the proposed practice site and follow the requirements in Appendix D.
- For all green infrastructure techniques that involve infiltration, adequate separation distance from ground water table and a reasonable drawdown time must be met.
- Green infrastructure techniques with storage capacity that are sited downstream from the developed areas must be sized for contributing areas (pervious and impervious covers), or sized for rainfall by run on.

New York State Stormwater Management Design Manual

Chapter 5: Green Infrastructure Practices

Section 5.3 Green Infrastructure Techniques

- Green infrastructure techniques without storage capacity that are sited downstream from the developed areas must be sized for receiving runoff from a maximum contributing area (pervious and impervious covers).
- Areas of green infrastructure techniques that do not receive runoff from developed areas can be subtracted from the contributing area of the downstream SMP for WQ_v calculation. The R_v of the SMP is calculated based on the pervious and impervious cover of the remaining contributing areas.
- If any other calculation methods are utilized (e.g. TR-55), all the contributing areas and related practices must be modeled according to the requirements of the selected method.
- All green infrastructure practices must be designed for over flow and safe passage of storms greater than the design capacity of the system and conveyed to facilities designed for quantity controls.
- A drainage layer shall be incorporated in most practices to enhance structural integrity, storage, drainage, and infiltration and may not be neglected.

New York State Stormwater Management Design Manual

Chapter 5: Green Infrastructure Practices

Section 5.3 Green Infrastructure Techniques

•

Table 5.7 Green Infrastructure Techniques for Runoff Reduction

| Practice | Description |
|--|---|
| Conservation of Natural Areas | Retain the pre-development hydrologic and water quality characteristics of undisturbed natural areas, stream and wetland buffers by restoring and/or permanently conserving these areas on a site. |
| Sheetflow to Riparian Buffers or Filter Strips | Undisturbed natural areas such as forested conservation areas and stream buffers or vegetated filter strips and riparian buffers can be used to treat and control stormwater runoff from some areas of a development project. |
| Vegetated Swale | The natural drainage paths, or properly designed vegetated channels, can be used instead of constructing underground storm sewers or concrete open channels to increase time of concentration, reduce the peak discharge, and provide infiltration. |
| Tree Planting / Tree Pit | Plant or conserve trees to reduce stormwater runoff, increase nutrient uptake, and provide bank stabilization. Trees can be used for applications such as landscaping, stormwater management practice areas, conservation areas and erosion and sediment control. |
| Disconnection of Rooftop Runoff | Direct runoff from residential rooftop areas and upland overland runoff flow to designated pervious areas to reduce runoff volumes and rates. |
| Stream Daylighting | Stream Daylight previously-culverted/piped streams to restore natural habitats, better attenuate runoff by increasing the storage size, promoting infiltration, and help reduce pollutant loads. |
| Rain Gardens | Manage and treat small volumes of stormwater runoff using a conditioned planting soil bed and planting materials to filter runoff stored within a shallow depression. |
| Green Roofs | Capture runoff by a layer of vegetation and soil installed on top of a conventional flat or sloped roof. The rooftop vegetation allows evaporation and evapotranspiration processes to reduce volume and discharge rate of runoff entering conveyance system. |
| Stormwater Planters | Small landscaped stormwater treatment devices that can be designed as infiltration or filtering practices. Stormwater planters use soil infiltration and biogeochemical processes to decrease stormwater quantity and improve water quality. |
| Rain Barrels and /Cisterns | Capture and store stormwater runoff to be used for irrigation systems or filtered and reused for non-contact activities. |
| Porous Pavement | Pervious types of pavements that provide an alternative to conventional paved surfaces, designed to infiltrate rainfall through the surface, thereby reducing stormwater runoff from a site and providing some pollutant uptake in the underlying soils. When designed in accordance with the design elements in section 5.3.11, the WQv for the contributing drainage area is applied towards the runoff reduction |

5.3.1 Conservation of Natural Areas

The purpose of this runoff reduction method is to retain the pre-development hydrologic and water quality characteristics of undisturbed natural areas (e.g. forest areas, stream and wetland buffers) by permanently conserving these areas on a site. By using this practice, a stormwater designer would be able to subtract the area to be designated as a conservation area from total contributing drainage area when computing water quality volume requirements. An added benefit will be that the post-development peak discharges will be smaller, and hence water quantity control volumes (C_p , Q_p , and Q_f) will be reduced due to lower post-development curve numbers. It should be noted that reducing reduced curve number will result in smaller runoff rate and volume. For stream or wetland buffers, reduction may only be applied when the actual stream or wetland is located substantially within the property boundaries of the site; in other words the property owner must have sole control of the buffer.

Storms at and below the WQv precipitation frequency (i.e., the 90% event), will not generate significant stormwater runoff from pervious surfaces depending on the soil type and compaction. The design of the stream or wetland buffer treatment system must use appropriate methods for conveying flows above the annual recurrence (1-yr storm) event. No change in either area or runoff curve number (CN) would be allowed for Q_p or Q_f for this credit.

Recommended Application of Practice

- Examples of natural area conservation include:
- Forest retention areas (including reforestation areas)
- Stream and river corridors, wetlands, vernal pools and associated buffers, as well as other lands in protective easement (e.g., floodplains, undisturbed open space)

Benefits

- Reduces the runoff treatment volume and reduces SMP storage volume and size
- Saves cost and possible land consumption for SMPs
- Provides permanent protection of open space that appeals to many residents and can increase property value

New York State Stormwater Management Design Manual

Chapter 5: Green Infrastructure Practices

Section 5.3 Green Infrastructure Techniques

- Promotes protection of natural hydrologic balance that maintains pre-developed groundwater recharge characteristics

Feasibility/Limitation

- Requires delineation, permanent protection and enforcement of buffers and natural areas
- Requires establishment of a legal protective easement
- Some sites may be too steep to effectively implement natural conservation areas
- May be perceived to limit development potential
- Some residents may perceive natural areas as potential nuisance areas for vermin and pests

Sizing and Design Criteria

- Subtract conservation areas from total contributing drainage area when computing water quality volume. This practice is not applicable if the Sheetflow to Riparian Buffer, or another area based practice, is already being taken for the same area. The conservation area must be an onsite drainage area that contributes runoff to the WQv.
- Conservation area cannot be disturbed during project construction.
- These natural areas should be delineated to maximize contiguous land area and avoid fragmentation.

Required Elements

- All conservation areas:
 - Shall have a minimum contiguous area requirement of 10,000 ft²
 - Shall be protected by limits of disturbance clearly shown on all construction drawings and marked in the field/project development site with structural barriers
 - Shall be located within an acceptable conservation easement instrument that ensures perpetual protection of the proposed area. The easement must clearly specify how the natural area vegetation shall be managed and boundaries will be marked [Note: managed turf (e.g., playgrounds, regularly maintained open areas) is not an acceptable form of vegetation management]
- Conservation areas that receive runoff from other contributing areas must be designed according to Sheetflow to Riparian Buffer requirements.
- Conservation areas that drain to any design point can be subtracted from the contributing area for WQv calculation.

Design Example

New York State Stormwater Management Design Manual

Chapter 5: Green Infrastructure Practices

Section 5.3 Green Infrastructure Techniques

Figure 5.31 Schematic diagram of residential subdivision illustrating preservation of natural conservation areas. Areas with cross-hatching are removed from site area when calculating water quality volume.

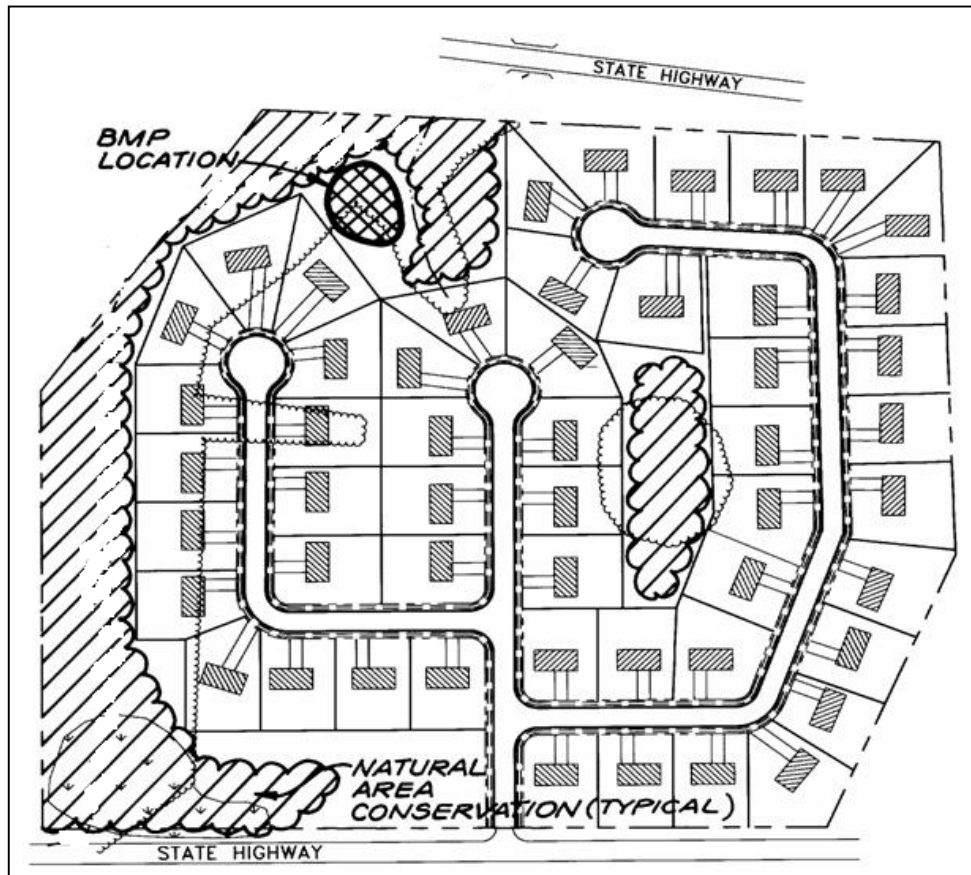

Base Data

Total contributing drainage area = 10 acres (Figure 5.32)

Proposed impervious area = 3 acres

90% Rainfall Event Number = 1.0 inch

Area to be protected as natural conservation area = 3.0 acres. In this scenario the conservation area is not receiving runoff and is subtracted from the contributing areas to a downstream SMP: $10-3=7$ acres

First, the volumetric runoff coefficient is computed:

For more information on the calculation of the volumetric runoff coefficient and other stormwater management design criteria, see Chapter 4 of this Design Manual.

Percentage of Impervious Cover: $3/7=0.43$

$$R_v = 0.05 + 0.009(43) = 0.44$$

New York State Stormwater Management Design Manual

Chapter 5: Green Infrastructure Practices

Section 5.3 Green Infrastructure Techniques

Next compute the required water quality volume:

$$WQV = (1.0 \text{ inch}) (0.44) (7 \text{ acres})/12 = 0.254 \text{ acre-feet.}$$

Under this runoff reduction practice, three acres of conservation are subtracted from total site area. Area changes from 10 to 7 acres. R_v is calculated accordingly. The reduction yields a smaller storage volume. If conservation area receives runoff from upstream areas, the Sheetflow to Riparian Buffer design and sizing requirement must be followed.

Note: It is acceptable for conservation areas to drain to proposed stormwater management treatment facilities (i.e., the SMP location in this example) and should be accounted for all other design storms.

5.3.2 Sheetflow to Riparian Buffers or Filter Strips

Description: Vegetated filter strips or undisturbed natural areas such as riparian buffers can be used to treat and control stormwater runoff from some areas of a development. Vegetated filter strips (a.k.a., grassed filter strips, filter strips, and grassed filters) are vegetated surfaces that are designed to treat sheet flow from adjacent surfaces and remove pollutants through filtration and infiltration. Riparian reforestation can be applied to existing impacted riparian area corridors.

Runoff can be directed towards riparian buffers and other undisturbed natural areas delineated in the initial stages of site planning to infiltrate runoff, reduce runoff velocity and remove pollutants. Natural depressions can be used to temporarily store (detain) and infiltrate water, particularly in areas with more permeable (hydrologic soil groups A and B) soils.

The objective in using natural areas for stormwater infiltration is to intercept runoff before it has become substantially concentrated and then distribute this flow evenly (as sheet flow) to the buffer or natural conservation area. This can typically be accomplished using a level spreader, as seen in Figure 5.33. A mechanism for the bypass of higher-flow events should be provided to reduce erosion or damage to a buffer or undisturbed natural area. Recommended buffer widths for various uses are indicated in Figure 5.34.

Carefully constructed berms can be placed around natural depressions and below undisturbed vegetated areas

Figure 5.32 Use of a level spreader with a riparian buffer

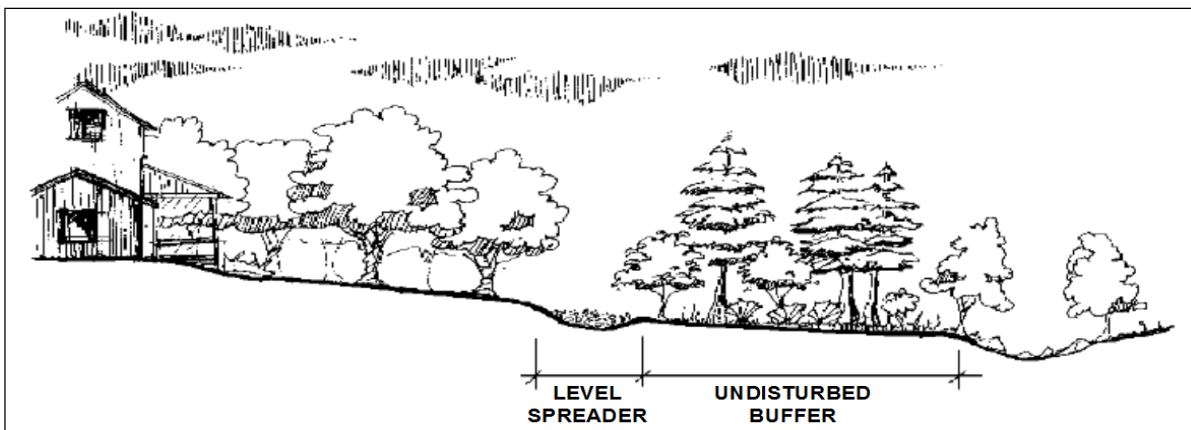

with porous soils to provide for additional runoff storage and/or infiltration of flows.

There are two design variants for sheet flow into filter strips and riparian buffers. The design, installation and management of these design variants are quite different, as shown in Table 5.8.

New York State Stormwater Management Design Manual

Chapter 5: Green Infrastructure Practices

Section 5.3 Green Infrastructure Techniques

Table 5.8 The Two Design Variations of the Filter Strip and Vegetative Buffer

| Design Issue | Sheetflow to Riparian Buffer | Sheetflow to Grass Filter Strip |
|---|--|--|
| Soil and Ground Cover | Undisturbed Soils and Native Vegetation | Amended Soils and Dense Turf Cover |
| Construction Stage | Located Outside the Limits of Disturbance and Protected by ESC controls | Prevent Soil Compaction by Heavy Equipment |
| Typical Application | Adjacent Drainage to Stream Buffer or Forest Conservation Area | Treat small areas of impervious cover (e.g., 5,000 sf) close to source |
| Compost Amendments | No | Yes |
| Boundary Spreader | GD at top of filter | GD at top of filter PB at toe of filter |
| Boundary Zone | 10 feet of level grass | At 25 feet of level grass |
| Concentrated Flow | ELS with 40 to 65 feet long level spreader* per one cfs of flow, depending on width of conservation area | ELS with length of level spreader per one cfs of flow |
| Maximum Slope, First Ten Feet of Filter | Less than 4% | Less than 2% |
| Maximum Overall Slope | 6% | 8% |
| GD: Gravel Diaphragm PB: Permeable Berm. ELS: Engineered Level Spreader, * See the NY Standards and Specifications for Erosion and Sediment Control for the design of level spreaders | | |

Recommended Application of Practice

- Direct runoff towards undisturbed riparian buffers or filter strips, using sheet flow or a level spreader to ensure sheet flow
- Use natural depressions for runoff storage
- Examine the slope, soils and vegetative cover of the buffer/filter strip
- Disconnect impervious areas to these areas
- Buffers may also be used as pretreatment

New York State Stormwater Management Design Manual

Chapter 5: Green Infrastructure Practices

Section 5.3 Green Infrastructure Techniques

Figure 5.33 Preservation of buffers for various environmental quality goals

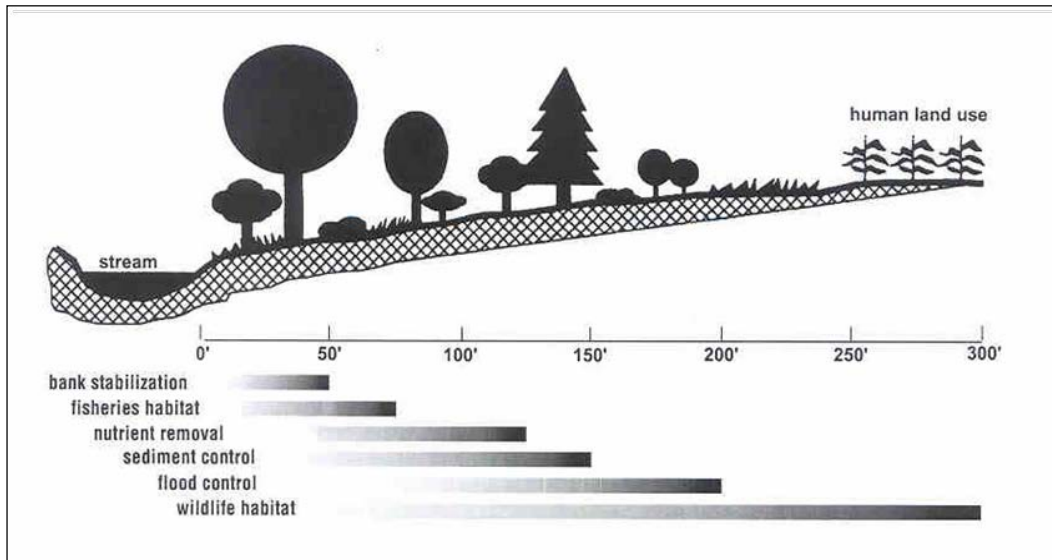

Benefits

- Riparian buffers and undisturbed vegetated areas can be used to filter and infiltrate stormwater runoff
- Natural depressions can provide inexpensive storage and detention of stormwater flows
- Can provide groundwater recharge
- Provides a valuable corridor for protection of stream or wetland and shoreline habitats
- Reduces the runoff volume that requires treatment and reduces SMP storage volume and size - See Figure 5.35
- Saves cost and possible land consumption for SMPs
- Promotes protection of natural hydrologic balance that maintains pre-developed groundwater recharge characteristics
- Reduces pollutant load delivery to receiving waters that will help meet water quality standard requirements

Feasibility /Limitations

- Require space – Use in areas where land is available and land costs are not significantly high
- Will not be available to sites without riparian areas or already forested riparian areas

Figure 5.34 Use of a vegetated filter



New York State Stormwater Management Design Manual

Chapter 5: Green Infrastructure Practices

Section 5.3 Green Infrastructure Techniques

- May be inappropriate in areas of higher pollutant loading due to direct infiltration of pollutants– Integrate with other practices to ensure adequate treatment prior to discharge
- Channelization and premature failure can occur. This can be alleviated with proper design, construction and maintenance
- Requires delineation, permanent protection of natural areas, and enforcement for buffer area protections to be effective
- Sheet flow to a buffer is difficult to maintain and enforce
- Some sites may be too steep to effectively implement these practices
- Some residents may perceive natural buffer areas as potential nuisance areas for vermin and pests
- May be difficult to maintain minimum buffer distances and contributing flow paths

Required Elements

Filter Strip and Riparian Buffers to stream and wetland:

- Maximum contributing length shall be 150 feet for pervious and 75 feet for impervious surfaces
- Runoff shall enter the buffer as overland sheet flow; a flow spreader can be supplied to ensure this, if average contributing slope criteria cannot be met (Note: a level spreader shall be used between buffer slopes ranging between 3% and 15%; for buffer slopes beyond 15% this practice cannot be applied)
- Minimum width of a vegetated filter strip or undisturbed riparian buffer shall be 50 feet for slopes of 0% to 8%, 75 feet for slopes of 8% to 12% and 100 feet for slopes of 12 % to 15 %.
- Buffers must be fully vegetated.
- Siting and sizing of this practice should address WQv and runoff reduction requirements and cannot result in overflow to undesignated areas.

Note: The NYS Freshwater Wetlands Act requires a 100-foot buffer for wetlands greater than 12.4 acres. Applicants required to meet other regulatory requirements are still eligible to meet the stream and wetland buffer credit provided the criteria cited above are also met.

Sizing and Design Criteria:

Subtract area draining by sheet flow to a riparian buffer or filter strip when computing the water quality volume. See Figure 5.36. If the area draining contains impervious surface, the Rv value is reduced as well. This practice is not applicable if the Disconnection of Rooftop Runoff or another area based practice is already being applied to this area.

New York State Stormwater Management Design Manual

Chapter 5: Green Infrastructure Practices

Section 5.3 Green Infrastructure Techniques

Figure 5.35 Illustration of stream buffer practice. Site areas draining to stream buffer that meet the specified criteria are removed from site area when calculating storage volumes for water quality.

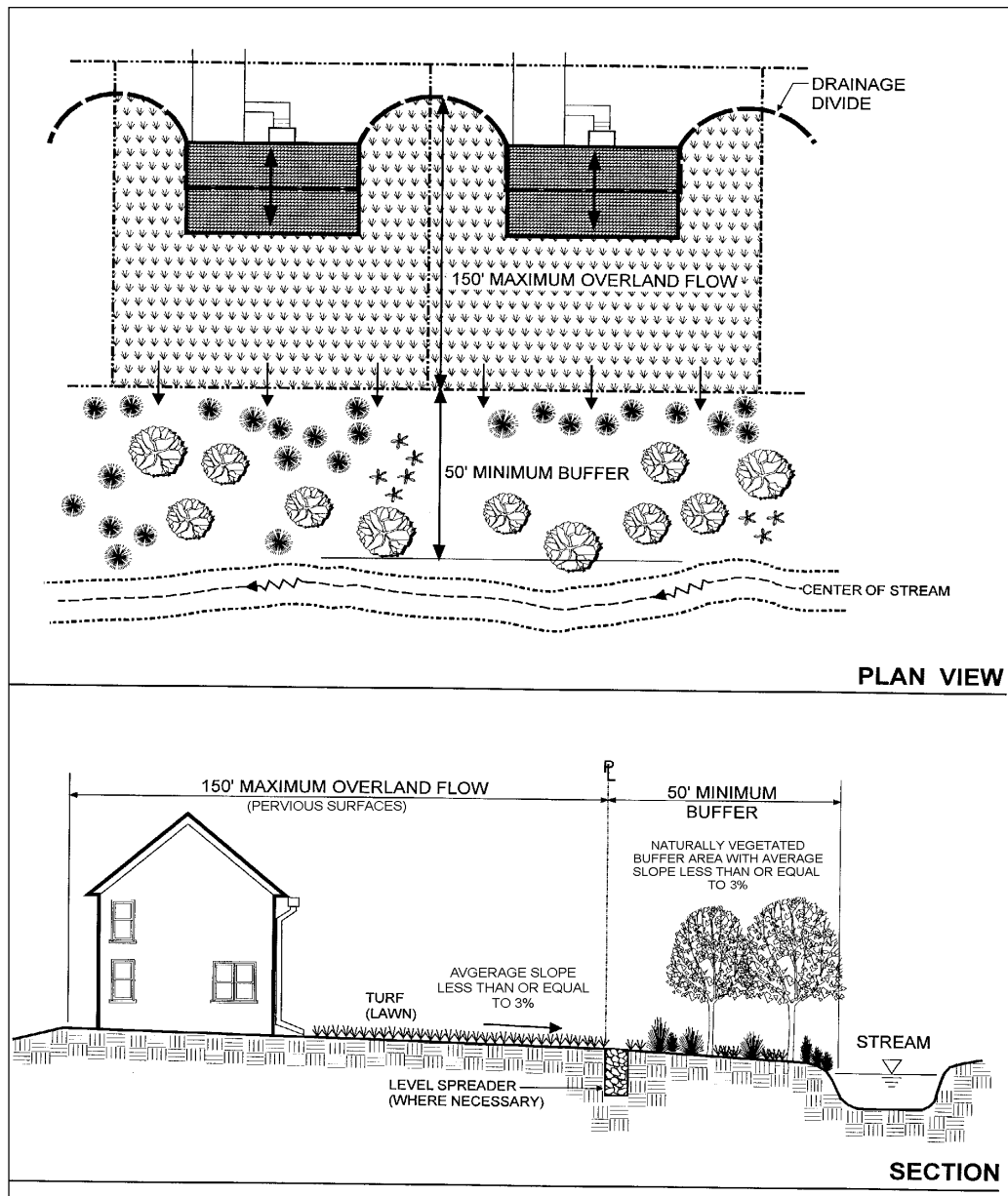

- Maximum contributing length shall be 150 feet for pervious surfaces and 75 feet for impervious cover
- In HSG C and D buffer length should be increased by 15%-20% respectively.
- For a combination of impervious cover (IC) and pervious cover (PC), use the following to determine the maximum length of each contributing area:
- $150 - IC =$ contributing length of PC (maximum IC = 75, maximum PC =150).

New York State Stormwater Management Design Manual

Chapter 5: Green Infrastructure Practices

Section 5.3 Green Infrastructure Techniques

- Example: $(75-IC)*2+IC$ = total of contributing length.
- The average contributing slope shall be 3% maximum unless a flow spreader is used
- Runoff shall enter the riparian corridor as overland sheet flow. A flow spreader can be supplied to ensure this, or if average contributing slope criteria cannot be met
- Not applicable if overland flow filtration/groundwater recharge is already credited for the same impervious cover
- Newly created riparian reforestation areas shall be maintained as a natural area

References/Further Resources

Center for Watershed Protection. 1998. *Better Site Design: A Handbook for Changing Development Rules in Your Community*. Available from www.cwp.org

City of Portland, Oregon. September 2004. *Stormwater Management Manual*. Bureau of Environmental Services, Portland, OR. Available from <http://www.portlandonline.com/bes/>

Prince George's County, MD. June 1999. *Low-Impact Development Design Strategies: An Integrated Design Approach*. Prince George's County, Maryland, Department of Environmental Resources, Largo, Maryland. Available from www.epa.gov

Virginia Department of Conservation and Recreation (VA DCR), Virginia DCR Stormwater Design Specification No.2, "Sheet Flow To A Filter Strip or Conserved Open Space", Version 1.6, Dated September 30, 2009.

5.3.3 Vegetated Swale

A vegetated swale is a maintained, turf-lined swale specifically designed to convey stormwater at a low velocity, promoting natural treatment and infiltration. A properly designed, constructed, and maintained channel (or, in some cases natural drainage path) can be used in both residential and non-residential areas as a runoff reduction practice. A vegetated swale can be an alternative to underground storm sewers or lined open channels. Where drainage area, topography, soils, slope and safety issues permit, vegetated swales can be used in the street right-of-way and on developed sites to convey and treat stormwater from roadways and other impervious surfaces.

When compared to underground pipes or hardened channels, vegetated swales increase the time-of-concentration (T_c), reduce the peak discharge and provide infiltration opportunities. A vegetated swale designed in accordance with the criteria in this section will provide modest (10-20%) runoff reduction for the water quality volume (WQv) for certain development conditions.

The vegetation height in a vegetated swale should be maintained at approximately 4 inches to 6 inches.

Note: Other types of swales are used for simple conveyance, diversion, conventional water quality treatment (wet and dry swales, Chapter 6) and pretreatment. Unique design and application criteria (different from vegetated swale) must be applied for each specific type of use.

Benefits

- Reduces the cost of road and stormwater conveyance construction
- Provides some runoff storage and infiltration, as well as treatment of stormwater
- If a vegetated swale is properly designed, a 10-20% reduction of WQv may be applied for sizing conventional treatment practices within the contributing DA
- The post-development peak discharges used to calculate “quantity” controls will likely be lower, due to a slightly longer T_c for the site
- Reduced maintenance costs

Feasibility/Limitations

- Local codes may not allow swales instead of curb and gutter or closed drainage pipes – *Meet with local officials to discuss waivers for alternative designs*

New York State Stormwater Management Design Manual

Chapter 5: Green Infrastructure Practices

Section 5.3 Green Infrastructure Techniques

- There is a perception that swales require more maintenance than curb and gutter or closed drainage pipes – *With the proper design and proper education of owners, swales require less maintenance and are less prone to failure*
- Lack of curbing may increase potential for failure of the pavement at the grass interface – *The potential for failure can be alleviated by hardening the interface by installing grass pavers, geosynthetics, or placing a compacted granular material strip along the pavement edge*
- Swales in residential neighborhoods are perceived to reduce property values and the “curb appeal” for re-sale, when compared to conventional curb and gutter street systems. – *Properly designed and maintained vegetated swale can be incorporated into landscaped lawn areas, with no impact to property value or neighborhood character*

Sizing Criteria

A vegetated swale can be used where the contributing DA is less than 5 acres, and when the WQv peak flow (Q_{WQV}) is less than 3cfs.

The WQv for a vegetated swale is computed in accordance with the uniform sizing criteria methods outlined in Chapter 4. Design flows are calculated using small storm hydrology (APPENDIX B), and conventional hydrology methods (Chapter 8) in conjunction with Manning’s equation for open channel flow.

For a properly designed vegetated swale, the following runoff reductions in the computed WQv may be applied to the water quality volume of the drainage area for which the swale is designed:

Hydrologic Group A and B soils – 20%

Hydrologic Group C and D soils – 10%

Modified* Hydrologic Group C and D soil – 15%-12%

**Modifications must be in accordance with Soil Restoration in Chapter 5 of this Manual.*

Required Elements

The vegetated swale design must:

- Receive peak water quality volume flow rates from the contributing drainage area that are no greater than 3 cfs
- Provide sufficient length (minimum 100 ft) to retain the computed treatment volume for 10 minutes in a swale that receives runoff as a point discharge at the inlet, or an average of 5 minutes of retention time for a swale receiving sheet drainage or multiple point discharges along its length

New York State Stormwater Management Design Manual

Chapter 5: Green Infrastructure Practices

Section 5.3 Green Infrastructure Techniques

- Convey the peak discharge for water volume flow (3 cfs or less):
 - a. at a velocity of ≤ 1.0 fps, and
 - b. at a flow depth of 4 inches or less
- Check Dam may be required to achieve the above criteria
- Have a trapezoidal or parabolic shape, with a bottom width minimum of 2' and no greater than 6'
- Have side slopes no steeper than 3 horizontal:1 vertical
- Have a slope between 0.5% and 4% (between 1.5- 2.5 percent recommended)
- Convey the 10-year storm with 6 inches of freeboard at a velocity ≤ 5 fps
- Use variable n values corresponding to flow depths (from .15 down to .03) (APPENDIX L)

Design Example

Design a vegetated swale to provide water quality runoff reduction treatment for a 4-acre section of a 30-acre residential development with eight ½-acre lots (25% impervious surfaces) on Hydrologic Soil Group B soils. This developed area will drain to a 625-foot long flow path on a natural gradient of 3.5%.

The following data has already been computed for the 4 acres:

$$WQ_v = 3,500 \text{ feet}^3 \text{ (90\% rule, Chapter 4)}$$

$$Q_{WQV} = 2.5 \text{ cfs (small storm hydrology, APPENDIX B)}$$

$$Q_{10} = 8.0 \text{ cfs (TR-55, Chapter 8)}$$

Try the following swale design:

A 2-foot deep trapezoidal channel with a bottom width of 4', with 1:3 side slopes, and a design slope of 3%.

Determine the Q_{WQV} flow depth and velocity (using Manning's equation iterations, computer programs or selected design charts):

$$Q = 1.49 / n \cdot A \cdot ((A/P)^{2/3}) \cdot S^{1/2}$$

$$\text{Area (for trapezoid)} = (\text{bottom width} + \text{top width})/2 \times \text{depth}$$

$$P \text{ (for trapezoid)} = \text{bottom width} + (\text{wetted side slope surface} \times 2)$$

$$S = \text{slope (ft/ft)}$$

$$n = \text{Manning's number}$$

New York State Stormwater Management Design Manual

Chapter 5: Green Infrastructure Practices

Section 5.3 Green Infrastructure Techniques

For a flow depth of 6”:

$$n = 0.12 \text{ (APPENDIX L, FIGURE L.1)}$$

$$S = 0.03 \text{ ft/ft}$$

$$A = [4' + (0.5' \times 3 \times 2) + 4'] / 2 \times 0.5$$

$$A = 2.75 \text{ ft}^2$$

$$P = 4 + [(0.5)^2 + (0.5 \times 3)^2]^{1/2} \times 2$$

$$P = 7.16 \text{ ft}$$

$$\text{Mannings: } Q = 1.49 / 0.12 \times 2.75 \times (2.75 / 7.16)^{2/3} \times (0.03)^{1/2}$$

$$Q = 3.1 \text{ cfs}$$

For $Q = 3.1$ cfs and flow depth of 6” (0.5’), velocity is 1.1 fps.

These conditions exceed the velocity limit.

Try a flatter 2.5% slope to reduce velocity and flow depth (using Manning’s equation iterations, computer programs or selected design charts):

For $Q = 2.5$ cfs, flow depth is 5.8” (0.48’) ($n = .125$), and velocity is 0.9 fps.

This swale design meets the depth and velocity criteria.

Determine the WQv flow retention time (at least 10 minutes) for the 625-foot long channel:

Flow length/velocity = detention time

$$625' / 0.9 \text{ fps} = 694 \text{ seconds} / 60 \text{ seconds} = 11.6 \text{ minutes}$$

The vegetated swale length provides sufficient retention of the WQv flow.

Determine the flow depth and velocity for Q_{10} (using Manning’s equation iterations, computer programs or selected design charts):

For $Q = 8.0$ cfs, flow depth = 8.5” (0.71’) ($n = .08$), and velocity is 1.8 fps ($is < 5$ fps).

The swale design meets the criteria for conveying a 10-year peak flow.

With a Q_{10} flow depth of 0.75’ and .5’ of freeboard, the design depth can be reduced from 2’ to 1.5’.

A 625-foot long, 1.5 foot deep trapezoidal channel with 1:3 side slopes and a 4-foot bottom width on a 2.5% slope on B soils will provide a 20% reduction in the water quality volume design requirement for the 8-lot section of development. New WQv = 3500 - 20% = 2800 feet³

Vegetative Requirements

- Strip vegetation, soil and debris from swale by hand where possible
- Amend soil as needed with fertilizer and lime

New York State Stormwater Management Design Manual

Chapter 5: Green Infrastructure Practices

Section 5.3 Green Infrastructure Techniques

- Provide 4 inches of topsoil
- Remove all stones and debris that may hinder flow and maintenance
- Apply recommended seed mixes (or sod) per Table 5.9

| Table 5.9 | | |
|------------------------------------|-----------------------------------|--|
| Mixtures | Rate per Acre (pounds) | Rate per 1,000 square feet (pounds) |
| A. Perennial ryegrass | 30 | 0.68 |
| Tall fescue or smooth bromegrass | 20 | 0.45 |
| Redtop | 2 | 0.05 |
| OR | | |
| B. Kentucky bluegrass ¹ | 25 | 0.60 |
| Creeping red fescue | 20 | 0.50 |
| Perennial ryegrass | 10 | 0.20 |

¹ Use this mixture in areas which are mowed frequently. Common white clover may be added if desired and seeded at 8 pounds/acre (0.2 pound/1,000 square feet).

- Roll or culti-pack seeds and mulch seed bed. Anchor mulching as needed.
- Water as needed

Maintenance Requirements

- Fertilize and lime as needed to maintain dense vegetation.
- Mow as required during the growing season to maintain grass heights at 4 inches to 6 inches.
- Remove any sediment or debris buildup by hand if possible in the bottom of the channel when the depth reaches 2 inches.
- Inspect for pools of standing water. Regrade to restore design grade and revegetate.
- Repair rills in channel bottom with compacted topsoil, anchored with mesh or filter fabric. Seed and mulch.
- Use of heavy equipment for mowing and removing plants/debris should be avoided to minimize soil compaction. Disturbed areas should be stabilized with seed and mulch, or revetment, as necessary.

New York State Stormwater Management Design Manual

Chapter 5: Green Infrastructure Practices

Section 5.3 Green Infrastructure Techniques

References/Further Resources

Center for Watershed Protection, 1996. *Design of Filtering Systems*. Available from www.cwp.org.

Center for Watershed Protection. 1998. *Better Site Design: A Handbook for Changing Development Rules in Your Community*. Available from www.cwp.org.

Center for Watershed Protection. August 2003. *New York State Stormwater Management Design Manual*. Prepared for New York State Department of Environmental Conservation, Albany, New York. <http://www.dec.state.ny.us/website/dow/toolbox/swmanual/#Downloads>.

City of Portland, Oregon. September 2004. *Stormwater Management Manual*. Bureau of Environmental Services, Portland, Oregon. Available from <http://www.portlandonline.com/bes/>.

[CSN](#) Technical Bulletin No. 4 Technical Support for the Bay-Wide Runoff Reduction Method Version 2.0. Available at www.chesapeakestormwater.net.

New York State Standards and Specifications for Erosion & Sediment Control. August 2005. Available from <http://www.dec.state.ny.us>.

Pennsylvania Stormwater Best Management Practices Manual. December 30, 2006. Available from [www.depweb.state.pa.us/watershed mgmt](http://www.depweb.state.pa.us/watershed_mgmt).

Prince George's County, MD. June 1999. *Low-Impact Development Design Strategies: An Integrated Design Approach*. Prince George's County, Maryland, Department of Environmental Resources, Largo, Maryland. Available from www.epa.gov.

5.3.4 Tree Planting/Tree Pit

Description:

Conserving existing trees or planting new trees at new or redevelopment sites can reduce stormwater runoff, promote evapotranspiration, increase nutrient uptake, provide shading and thermal reductions, and encourage wildlife habitat. The technique is similar to riparian restoration but is generally conducted on a smaller scale. It is uniquely suited to new and redevelopment in urban and suburban areas.

Tree planting generally refers to concentrated groupings of trees planted in landscaped areas while tree pits, also called tree boxes, generally refer to individually planted trees in contained areas such as sidewalk cut-outs or curbed islands.

Tree planting can be used for applications such as landscaping, stormwater management practice areas, conservation areas and erosion and sediment control. However, stormwater management practices listed in Chapter 6 and areas designated for other runoff reduction techniques cannot also be considered as runoff reduction areas for this technique.

Recommended Application of the Practice

- Conservation of existing trees is recommended where stands of existing trees are non-invasive, healthy and likely to continue to flourish in the proposed site conditions.
- Planting of new trees is recommended for areas that will remain or become pervious in the proposed condition and are large enough to sustain multiple trees.
- Planting of trees in tree pits is recommended in street rights-of-way or other small-scale pervious areas in highly impervious redevelopment sites that can support limited tree development. See Figure 5.37.

**Figure 5.36 Mature trees conserved during development
(Photo Sources: Randall Arendt and Ed Gilman)**



Benefits

- Tree planting can reduce stormwater volumes and velocities discharging from impervious areas through rainfall interception and evapotranspiration (ET).
- Planting trees can increase nutrient uptake, reduce runoff, aid infiltration, provide wildlife

New York State Stormwater Management Design Manual

Chapter 5: Green Infrastructure Practices

Section 5.3 Green Infrastructure Techniques

habitat, provide shading, discourage geese and reduce mowing costs.

- Trees contribute to the processes of air purification and oxygen regeneration.
- Mature trees can reduce urban heat island, decrease heating and cooling costs, block UV radiation.
- Mature trees buffer wind and noise.
- Tree planting can increase property values.

Feasibility/Limitations

- While tree planting can enhance stormwater management goals, it is not a “stand alone” treatment or management practice.
- Local codes may restrict trees in certain areas. Consult with local officials to discuss waivers for alternative designs.
- Overhead and underground utilities may limit the types of trees that can be planted and their location.
- Trees may not survive through construction or in certain urban environments unless proper tree selection, landscape design, protection and maintenance are incorporated in the technique. Inadequate soil rooting volumes and compacted soils are the largest factors in tree decline, and can lead to cracked and lifted pavements, curbs and retaining walls.
- Native vegetation may be perceived to harbor undesirable wildlife and insects. However, most people enjoy viewing wildlife, and native vegetation does not provide a food source for most vermin. Continued education is necessary to show that humans and wildlife can co-exist, even at the neighborhood level.

Sizing and Design Criteria

- For tree planting, runoff reduction may be determined using the same method as Riparian Buffer practice (Section 5.3.2). The area considered for runoff reduction is limited to the pervious area in which trees are planted. In an urban setting where trees are contained by impervious structures such as curbs and sidewalks, the area is calculated as follows: For up to a 16-foot diameter canopy of a mature tree, the area considered for reduction shall be ½ the area of the tree canopy. For larger trees, the area credited is 100 SF per tree. This can be considered the drainage area into the below grade tree pit.
- An alternative sizing for runoff reduction in urban setting may follow the bioretention or stormwater planters (with infiltration) design and sizing. In this case sizing of the practice relies on storage capacity of the soil voids in the cavity created for the root ball of the tree and the ponding area. The infiltration rate of the in-situ soil must be a minimum of 2 inches per hour.

Required Elements

New York State Stormwater Management Design Manual

Chapter 5: Green Infrastructure Practices

Section 5.3 Green Infrastructure Techniques

Conservation of existing native trees during the development process should be managed in a systematic manner using the following steps:

1. Inventory existing trees on-site.
2. Identify trees to be protected.
3. Design the development with conservation of these trees in mind.
4. Protect the trees and surrounding soils during construction by limiting clearing, grading and compaction.
5. Protect and maintain trees post construction.

Where conservation of existing trees is utilized:

- A directly connected impervious area reduction equal to one-half the canopy area is permitted and is only applied to the area adjacent to the tree.
- The tree species must be chosen from the approved list (see Landscape Guidance of this Manual or a consult local list of native species).
- Existing trees whose canopies are within 20 horizontal feet of directly connected ground level impervious areas can be used for runoff reduction.
- Existing trees must be at least 4-inch caliper to be eligible for the reduction.
- Applicable to trees within the subject drainage area

For planting of new trees, maximize the use of pervious areas on the site that are good locations for tree planting. For example: road rights-of-way, landscaped islands in cul-de-sacs or traffic circles, parking lots, and private lawns. These urban planting sites may have harsh soil and environmental conditions that must be addressed through appropriate species selection or proper site preparation prior to planting.

Where new trees are planted:

- The tree species must be chosen from the approved list (see Landscape Guidance of this Manual or a consult local list of native species).
- New trees planted must be planted within 10 feet of ground-level, directly connected impervious areas.
- New deciduous trees must be at least 2-inch caliper and new evergreen trees must be at least 6 feet tall to be eligible for the reduction.
- A 100 square-foot directly connected impervious area reduction is permitted for each new tree. This credit may only be applied to the impervious area adjacent to the tree.

New York State Stormwater Management Design Manual

Chapter 5: Green Infrastructure Practices

Section 5.3 Green Infrastructure Techniques

- Recommend minimum 1,000 cubic feet soil media available per tree.

For new trees, the average slope for the contributing area, including the area under the canopy must not be greater than 5%. The maximum slope can be increased where existing trees are being preserved. Slope specifications for filter strips and buffers should be followed as guidelines. The maximum reduction permitted, for both new and existing trees, is 25% of directly connected ground level impervious area.

Example

One example of tree planting is where single tree planting within impervious area is utilized. For such scenarios the stormwater planter example, as a storage or flow through system, should be used.

Another example is where a group of trees within a reasonably large pervious area is planted. In such scenarios, planting area can be used for impervious cover disconnection. Follow Rooftop Disconnection or Sheet Flow to Filter Strip example. If the tree planting area is connected to an SMP and discharges to a design point, the area reduction example for natural area conservation can be followed.

Environmental/Landscaping Elements

- Adequate space must be provided for each tree to grow.
- Trees should be selected for diversity and to promote native, non-invasive species.
- Soil quality and volume may be poor. Soil amendments and decompaction may be required prior to planting. Heavy equipment traffic should be limited in the vicinity of both existing and proposed tree planting areas.
- **Maintenance**
 - During the first three years, mulching, watering and protection of young trees may be necessary and should be included in the inspection list.
 - Inspections should be performed every three months and within one week of ice storms, within one week of high wind events that reach speeds of 20 mph until trees have reached maturity, and according to established tree inspection requirements as identified within this document.
 - As a minimum, the following items should be included in the regular inspection list:
 - Assess tree health
 - Determine survival rate; replace any dead trees.
 - 1) Inspect tree for evidence of insect and disease damage; treat as necessary
 - 2) Inspect tree for damages or dead limbs; prune as necessary

New York State Stormwater Management Design Manual

Chapter 5: Green Infrastructure Practices

Section 5.3 Green Infrastructure Techniques

References/Further Resources

American Forests website: www.americanforests.org

American National Standards Institute. 2004. ANSI Z60.1-2004. American Standards for Nursery Stock. 112 p.

Cappiella, K., T. Schueler, T. Wright. 2004. Urban Watershed Forestry Manual. Available from www.cwp.org

City of Toronto Tree Advocacy Planting Program website:
<http://www.city.toronto.on.ca/parks/treadvocacy.htm>

CSN Technical Bulletin No. 4, Technical Support for the Baywide Runoff Reduction Method, Version 2.0
<http://www.chesapeakestormwater.net/all-things-stormwater/technical-support-for-the-baywide-runoff-reduction-method.html>

International Society of Arboriculture website: <http://www.isa-arbor.com/publications>.

Stormwater Management Guidance Manual City of Philadelphia Version 2.0, Philadelphia Water Department Office of Watersheds,
<http://www.phillyriverinfo.org/WICLibrary/PSMGM%20V2.0.pdf>, last visited 10/28/09.

NYC Department of Design & Construction Office of Sustainable Design
http://www.nyc.gov/html/ddc/downloads/pdf/ddc_sd-sitedesignmanual.pdf

New York State Stormwater Management Design Manual

Chapter 5: Green Infrastructure Practices

Section 5.3 Green Infrastructure Techniques

5.3.5 Disconnection of Rooftop Runoff

Direct runoff from residential rooftop areas to designated pervious areas to reduce runoff volumes and rates. This practice may only be applied when “filtration/infiltration areas” are incorporated into the site design to receive runoff from rooftops. This can be achieved by grading the site to promote overland vegetative filtering or by providing infiltration areas (figure 5.38). If impervious areas are adequately disconnected, they can be treated as pervious area when computing the water quality volume requirements (resulting in a smaller R_v). Impervious areas are not deducted when calculating controls for larger storms but post-development peak discharges used to calculate “quantity” controls will likely be lower due to a longer time of concentration for the site.

Benefits

- Sending runoff to pervious areas and lower-impact practices increases overland flow time and reduces peak flows.
- Vegetated and pervious areas can filter and infiltrate runoff, thus increasing water quality.

Feasibility/Limitations

- Wet basements will result from re-directing rooftop runoff – *careful design and construction inspection will minimize this condition;*
- Re-directed rooftop runoff may increase a property owner’s maintenance burden;
- Alternative rooftop runoff mitigation may be costly – *Rain barrels in fact are inexpensive and will reduce water use costs; green roofs reduce heating and cooling costs and roof replacement costs.*
- Local law may prohibit or limit rooftop disconnection.

Figure 5.37 Disconnection of rooftop to designated vegetated areas. Otter Creek, NY, NYSDEC.



Sizing and Design Criteria

If impervious areas are adequately disconnected, they can be deducted from the site’s impervious total (R_v calculation) when computing WQ_v . Stormwater quantity and quality benefits can be achieved by routing runoff from rooftop areas to pervious areas such as lawns, landscaping, and depressed areas designated for infiltration. As with undisturbed buffers and natural areas, designated, revegetated areas such as lawns can act as biofilters for stormwater runoff and provide for infiltration in more permeable soils (hydrologic groups

New York State Stormwater Management Design Manual

Chapter 5: Green Infrastructure Practices

Section 5.3 Green Infrastructure Techniques

A and B). Areas designated to receive runoff from rooftop disconnection must be properly graded for infiltration and conveyance in a non-erosive manner within the site boundary.

Required Elements

- Runoff from disconnected rooftop must be directed to a designated area that is appropriately graded for storage and infiltration of the runoff, re-vegetated and protected from other uses, and designed for conveyance in a non-erosive manner within the site boundary (Figure 5.39). Use splash pads or level spreaders (See the NY Standards and Specifications for Erosion and Sediment Control for the design of level spreaders) as required to distribute runoff to designated areas with infiltration capacity
- Disconnections are encouraged on permeable soils (HSGs A and B);
- In less permeable soils (HSGs C and D), permeability as well as water table depth and shall be evaluated by a certified/licensed professional to determine if a soil enhancement and spreading device is needed to provide sheet flow over grass surfaces. In some cases, soil restoration by deep tilling, de-compaction, compost amendment are needed to compensate for a poor infiltration capability;
- Runoff shall not come from a designated hotspot as listed in Section 4.11 of this Manual;
- The maximum contributing flow path length from impervious areas shall be 75 feet;
- Downspouts shall be at least 10 feet away from the nearest impervious surface to discourage “re-connections”;
- The contributing area of rooftop to each disconnected discharge shall be 500 square feet or less; larger roof areas up to 2,000 square feet may be acceptable with a suitable flow dispersion technique such as a level spreader;
- The disconnected, contributing impervious area shall drain through a vegetated channel, swale, or filter strip (filtration/infiltration areas) for a distance equal to or greater than the disconnected, contributing impervious area length;
- The entire vegetative filtration/infiltration area shall have an average slope of less than five (5) percent;
- Siting and sizing of this practice should address WQv and runoff reduction requirements and cannot not result in overflow to undesigantated areas.

Figure 5.38 Rooftop disconnection for storage and infiltration, Guilderland, NY, NYSDEC



New York State Stormwater Management Design Manual

Chapter 5: Green Infrastructure Practices

Section 5.3 Green Infrastructure Techniques

- For those areas draining directly to a buffer, either the Disconnection of Rooftop Runoff or Sheetflow to Riparian Buffer runoff reduction method can be used, but not both;
- Use splash pads or level spreaders as required to distribute runoff to designated areas with infiltration capacity.

Example Calculation

Base Data

Site Data: 108 Single Family Residential Lots (~ ½ acre lots, Figure 5.40)

Assume site is in Saratoga Springs, NY, where 90% rainfall = 1.0 inch.

Site Area = 45.1 ac

Original Impervious Area = 12.0 ac; or $I = 12.0/45.1 = 26.6\%$

Original $R_v = 0.05 + 0.009(26.6) = 0.29$

Original $WQ_v = (1.0 \text{ inch}) (0.29) (45.1 \text{ acres})/12 = 1.09 \text{ acre-feet}$

Disconnection of Rooftop Runoff (see Figure 5.39)

42 houses disconnected to a designated, permanent, vegetated easement

Average house area = 2,000 ft²

Net impervious area reduction = $(42)(2,000 \text{ ft}^2) / (43,560 \text{ ft}^2/\text{ac}) = 1.93 \text{ acres}$

New impervious area = $12.0 - 1.93 = 10.1 \text{ acres}$; or $I = 10.1/45.1 = 22.4\%$

New $R_v = 0.05 + .009(22.4) = 0.25$

New $WQ_v = (P)(R_v)(A)/12 = (1.0 \text{ in})(0.25)(45.1)/12 = 0.95 \text{ acre-feet}$

Percent Reduction Using Disconnection of Rooftop Runoff:

$WQ_v = (1.09 - 0.95) / 1.09 = 13.3\%$

New York State Stormwater Management Design Manual

Chapter 5: Green Infrastructure Practices

Section 5.3 Green Infrastructure Techniques

Figure 5.39 Schematic of rooftop disconnection to Filtration/Infiltration Zones. Impervious rooftop areas are treated as pervious for the calculation of water quality volume.

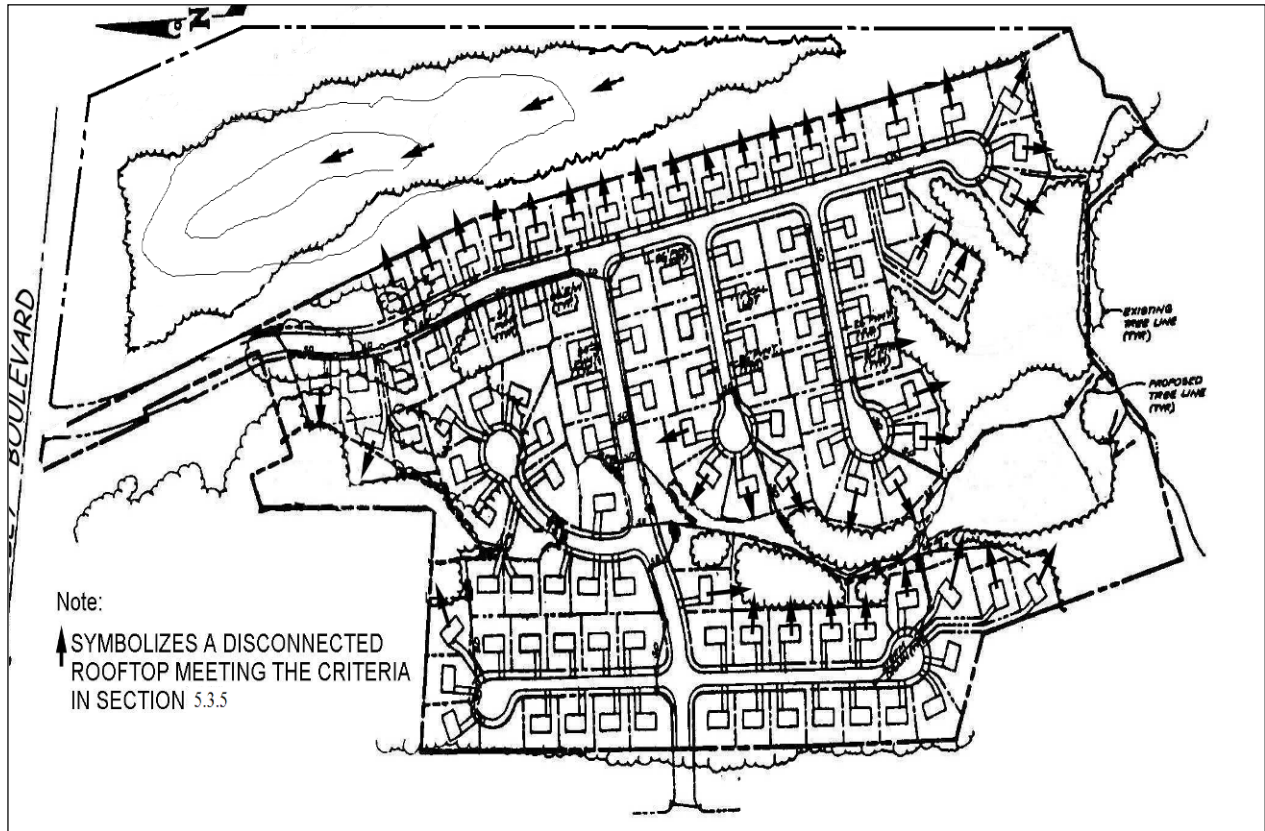

References/Further Resources

Virginia DCR Stormwater Design Specification No. 1, Rooftop (Impervious Surface) Disconnection, Version 1.7, 2010

<http://www.chesapeakestormwater.net/all-things-stormwater/rooftop-disconnection-design-specification.html>

Maryland Stormwater Design Manual, Volumes I & II, Chapter 5(Effective October 2000)

http://www.mde.state.md.us/programs/waterprograms/sedimentandstormwater/stormwater_design/index.asp

5.3.6 Stream Daylighting

Description: Stream Daylight previously-culverted/piped streams to restore natural habitats, better attenuate runoff by increasing the storage size, promoting infiltration, and help reduce pollutant loads where feasible and practical. Stream daylighting may be credited as an Impervious Area Reduction practice for redevelopment projects in accordance with Chapter 9.

Stream daylighting involves uncovering a stream or a section of a stream that had been artificially enclosed in the past to accommodate development. The original enclosure of rivers and streams often took place in urbanized areas through the use of large culvert operations that often integrated the storm sewer system and combined sanitary sewers. The daylighting operation, therefore, often requires overhauls or updating of storm-drain systems and re-establishing stream banks where culverts once existed. When the operation is complete, what was once a linear pipe of heavily polluted water can become a meandering stream with dramatic improvements to both aesthetics and water quality.

Applications

- Consider daylighting when a culvert replacement is scheduled
- Restore historic drainage patterns by removing closed drainage systems and constructing stabilized, vegetated streams, see Figure 5.41
- Carefully examine flooding potential, utility impacts and/or prior contaminated sites
- Consider runoff pretreatment and erosion potential of restored streams/rivers

Benefits

- Improves water quality
- Prevents flooding by increasing storage and reducing peak flows
- Increases habitat and wildlife value
- Increases pedestrian traffic and general public use
- Increases property values
- Aesthetic appeal of daylighted streams can be expected to add appeal to neighborhoods or urban areas

Limitations

New York State Stormwater Management Design Manual

Chapter 5: Green Infrastructure Practices

Section 5.3 Green Infrastructure Techniques

- Daylighting a stream can be expensive - *Costs for daylighting streams are often comparable to costs for replacing culverts*
- Maintenance of daylighted stream areas can be intensive during the first years the stream is established – *Once the banks are well established, regular maintenance is similar to that required in any public green space such as trash removal, mowing and general housekeeping*
- Finding the original stream channel may be difficult – *examine historic records, soils, and up and downstream channel characteristics.*
- Political backing and public support is more difficult for daylighting streams than for surface restoration because the culvert is not seen – *Provide proper public education and outreach about the benefits and how safety issues will be addressed.*

Figure 5.40 Before and after daylighting Blackberry Creek in Berkeley, CA (Source: Stormwater Magazine, Nov/Dec 2001)



Sizing and Design Criteria

Stream daylighting is applicable only to redevelopment projects as an impervious area reduction type practice in accordance with Chapter 9. The sizing of the stream channel must, at minimum, equal or exceed the existing drainage capacity of the piped drainage system.

The impervious area reduction credited under Chapter 9 would be equal to the area of imperviousness removed for streams buried and piped under impervious areas. For streams buried and piped under pervious areas, the impervious area reduction credited would be equal to the planar area of the bed and banks of the daylighted stream.

New York State Stormwater Management Design Manual

Chapter 5: Green Infrastructure Practices

Section 5.3 Green Infrastructure Techniques

Where combined sewer overflow (CSO) separation and other upgrades to storm-sewer systems are part of a daylighting project, significant water-quality improvements can be expected during wet-weather events. Also, as ultraviolet radiation is one of the most effective ways to eliminate pathogens in water, exposing these streams to sunlight could significantly decrease pathogen counts in the surface water.

Stream daylighting can play an integral role in neighborhood restoration and site redevelopment efforts. Aside from improvements to infrastructure, stream daylighting can restore floodplain and aquatic habitat areas, reduce runoff velocities and be integrated into pedestrian walkway or bike- path design.

Stream daylighting can generally be applied most successfully to sites with considerable open or otherwise vacant space. This space is required to: 1) Potentially reposition the stream in its natural stream bed; 2) Accommodate the meandering that will be required if a natural channel is being designed and 3) Provide adjacent floodplain area to store water in large storm-flow situations.

References/Further Resources

Blankinship, Donna Gordon. Jan/Feb 2005. *Creeks are Coming Back into the Light*. Article from Stormwater Magazine Vol. 6, No. 1. Forester Communications. Caledonia, MI. Available from www.stormh2o.com

Pinkham, Richard. Nov/Dec 2001. *Daylighting: New Life for Buried Streams*. Article from Stormwater Magazine Vol. 2, No. 6. Forester Communications. Caledonia, MI. Available from www.stormh2o.com

Rhode Island Department of Environmental Management. January 2005. *The Urban Environmental Design Manual*. Rhode Island Department of Environmental Management, Providence, Rhode Island. Available from <http://www.dem.state.ri.us/programs/bpoladm/suswshed/pubs.htm>

5.3.7 Rain Gardens

Description: The rain garden is a stormwater management practice intended to manage and treat small volumes of stormwater runoff from impervious surfaces using a conditioned planting soil bed and planting materials to filter runoff stored within a shallow depression. This practice is most commonly used in residential land use settings. The method is a variation on bioretention and combines physical filtering and adsorption with bio-geochemical processes to remove pollutants. Rain gardens are a simplified version of bioretention and are designed as a passive filter system without an underdrain connected to the storm drain system. A gravel drainage layer is typically used for dispersed infiltration. Rainwater is directed into the garden from residential roof drains, driveways and other hard surfaces. The runoff temporarily ponds in the garden and seeps into the soil over one to two days. The system consists of an inflow component, a shallow ponding area over a planted soil bed, mulch layer, gravel filter chamber, attractive shrubs, grasses and flowers, and an overflow mechanism to convey larger rain events to the storm drain system or receiving waters (see Figures 5.42 and 5.43).

Figure 5.41 Profile of a typical rain garden

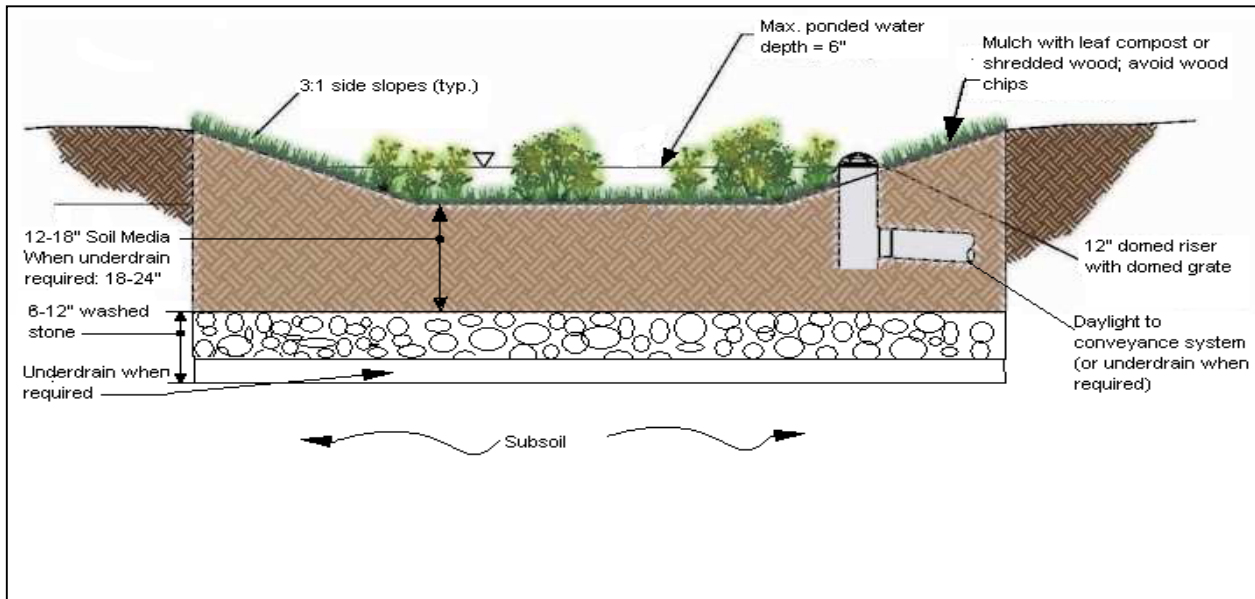
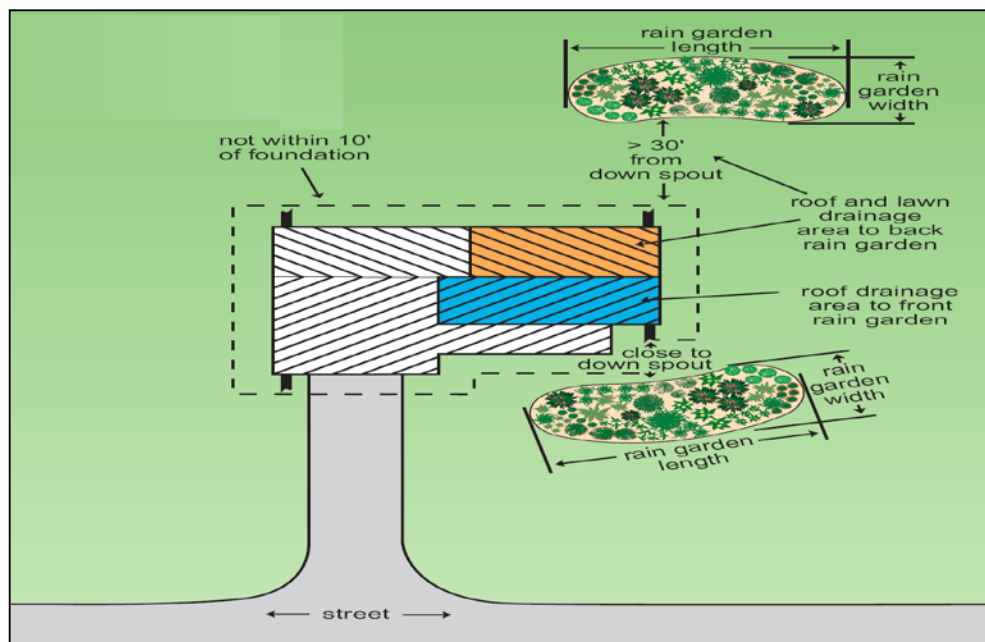

Figure 5.42 Layout of typical rain gardens



Recommended Application of the Practice

The rain garden is suitable for townhouse, single family residential, and in some institutional settings such as schoolyard projects, for treating small volumes of storm runoff from rooftops, driveways, and sidewalks. Since rain gardens do not need to be tied directly into the storm drain system, they can be used to treat areas that may be difficult to otherwise address due to inadequate head or other grading issues. Rain gardens are designed as an “exfilter,” allowing rainwater to slowly seep through the soil. They have a prepared soil mix and should be designed with a deeper gravel drainage layer chamber to improve treatment volume, and to compensate for clays and fines washing into the area. Rain garden size can range from 40 - 300 square feet for a residential area. Rain gardens can be integrated into a site with a high degree of flexibility and work well in combination with other structural management systems, including porous pavement, infiltration trenches, and swales.

Benefits

- Rain gardens can have many benefits when applied to redevelopment and infill projects in urban settings. The most notable include:
- Pollutant treatment for residential rooftops and driveways, (solids, metals, nutrients and hydrocarbons)
- Groundwater recharge augmentation
- Micro-scale habitat

New York State Stormwater Management Design Manual

Chapter 5: Green Infrastructure Practices

Section 5.3 Green Infrastructure Techniques

- Aesthetic improvement to turfgrass or otherwise hard urban surfaces (Figure 5.44)
- Ease of maintenance, coupling routine landscaping maintenance with effective stormwater management control and reduced turfgrass maintenance
- Promotion of watershed education and stewardship
- Rain gardens require a modest land area to effectively capture and treat residential runoff from storms up to approximately the 1-inch precipitation event.

Feasibility/Limitations

Rain gardens have some limitations, similar to bioretention, that restrict their application. The most notable of these include:

- Steep slopes - Rain gardens require relatively flat slopes to be able to accommodate runoff filtering through the system. Some design modifications can address this constraint through the use of berms and timber or block retaining walls on moderate slopes.

Figure 5.43 Rain gardens also have aesthetic value

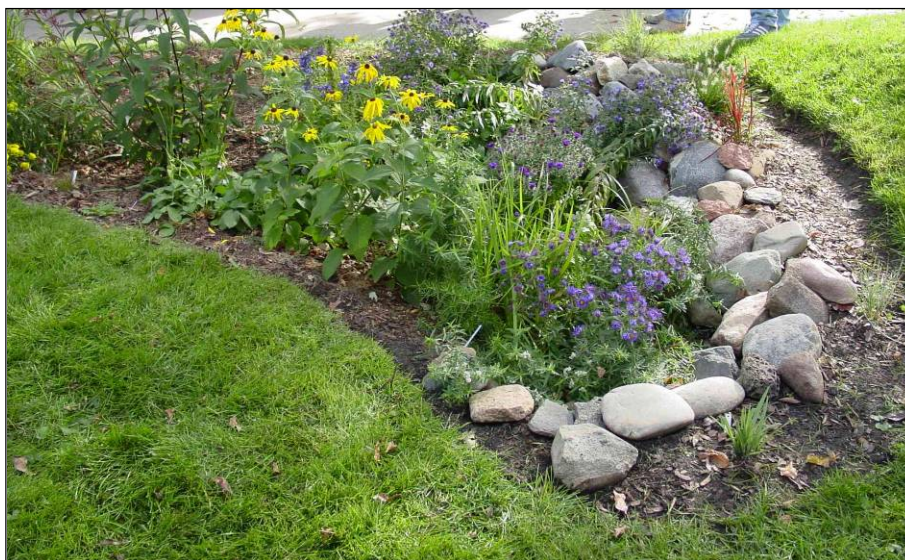

- Compacted and clay sub-soils - Sub-soils compacted by construction and heavy clay soils may need more augmentation by mechanical means (deep tine aeration or deep ripping) to provide appropriate infiltration or should be designed as a filter with under drains. A single rain garden system should be designed to receive sheet flow runoff or shallow concentrated flow from an impervious area or from a roof drain downspout with a total contributing drainage area equal to or less than 1,000 square feet. Treatment of larger drainage areas should incorporate the design elements of bioretention practices. Because the system works by filtration through a planting media, runoff must enter at the surface.
- The rain garden must be sited in a location that allows overflow from the contributing drainage area to sheet flow or be otherwise safely conveyed to the formal drainage system. Rain gardens should be located downgradient and at least 10 feet from basement foundations.
- Rain gardens should not be located in areas with heavy tree cover, as the root systems will make installation difficult and may be damaged by the excavation.

New York State Stormwater Management Design Manual

Chapter 5: Green Infrastructure Practices

Section 5.3 Green Infrastructure Techniques

- Rain gardens cannot be used to treat parking lot or roadway runoff. Treatment of these areas and other areas of increased pollutant loading should incorporate the design elements of a bioretention practice.

Sizing and Design Criteria

Stormwater quantity reduction in rain gardens occurs via evaporation, transpiration, and infiltration, though only the infiltration capacity of the soil and drainage system is considered for water quality sizing. The storage volume of a rain garden is achieved within the gravel drainage layer bed, soil medium and ponding area above the bed. The size should be determined using the water quality volume (WQv), calculated for the drainage area contributing to the rain garden. The storage volume in the rain garden must be equal to or greater than the water quality volume (WQv) in order to receive credit towards the runoff reduction volume. Rain gardens without underdrains in good soils can reduce the total WQv. Those constructed on poor soils cannot achieve runoff reduction more than 40% of total WQv. Instead of using an underdrain, it is recommended to increase the surface area of the rain garden. The available volume in the garden is determined by multiplying the volume of each layer by its porosity and adding the ponding volume. The following sizing criteria is followed to arrive at the minimum surface area of the rain garden, based on the required WQv:

$$WQV \leq V_{SM} + V_{DL} + (D_P \times A_{RG})$$

$$V_{SM} = A_{RG} \times D_{SM} \times n_{SM}$$

$$V_{DL} \text{ (optional)} = A_{RG} \times D_{DL} \times n_{DL}$$

where:

V_{SM} = volume of the soil media [cubic feet]

V_{DL} = volume of the gravel drainage layer [cubic feet]

A_{RG} = rain garden surface area [square feet]

D_{SM} = depth of the soil media, typically* 1.0 to 1.5 [feet]

D_{DL} = depth of the drainage layer, minimum 0.5 [feet]

D_P = depth of ponding above surface, maximum 0.5 feet [feet]

n_{SM} = porosity of the soil media ($\geq 20\%$)

n_{DL} = porosity of the drainage layer ($\geq 40\%$)

WQV = Water Quality Volume [cubic feet], as defined in Chapter 4

A simple example for sizing rain gardens based upon WQv is presented in Table 5.10.

*Maximum depth in soil types C and D is one foot.

New York State Stormwater Management Design Manual

Chapter 5: Green Infrastructure Practices

Section 5.3 Green Infrastructure Techniques

Required Elements

Siting: Rain gardens should be located as close as possible (without causing damage to structures) to the impervious areas that they are intended to treat. Although some vegetated areas will drain to the rain garden, they should be kept to a minimum to maximize the treatment of impervious areas. Rain gardens should be located within approximately 30 feet of the downspout or impervious area treated. Rooftop conveyance to the rain garden is through roof leaders directed to the area, with stone or splash blocks with dispersive stone spreaders placed at the point of discharge into the rain garden to prevent erosion. Runoff from driveways and other paved surfaces should be directed to the rain garden at a non-erosive rate through shallow swales, or allowed to sheet flow across short distances (Figure 5.44).

Sizing: The following considerations should be given to design of the rain garden (after PA Stormwater Design Manual, Bannerman 2003 and LID Center):

- Ponding depth above the rain garden bed should not exceed 6 inches. The recommended maximum ponding depth of 6 inches provides surface storage of stormwater runoff, but is not too deep to affect plant health, safety, or create an environment of stagnant conditions. On perfectly flat sites, this depth is achieved through excavation of the rain garden and backfilling to the appropriate level; on sloping sites, this depth can be achieved with the use of a berm on the downslope edge, and excavation/backfill to the required level.
- Surface area is dependent upon storage volume requirements but should not exceed a loading ratio of 5:1 (drainage area to infiltration area, where drainage area is assumed to be 100% impervious; to the extent that the drainage area is not 100% impervious, the loading ratio may be modified).
- A length to width ratio of 2:1 with long axis perpendicular to slope and flow path is recommended.

Soil: The composition of the soil media should consist of 50%-70% sand (less than 5% clay content), 50%-30% topsoil with an average of 5% organic material, such as compost or peat, free of stones, roots and woody debris and animal waste.. The depth of the amended soil should be approximately 4 inches below the bottom of the deepest root ball.

Table 5.10 Rain Garden Simple Sizing Example

Given a 1,000 square foot impervious drainage area (e.g., rooftop), a rain garden design has been proposed with a 200 square foot surface area, a soil layer depth of 12 inches, a drainage layer depth of 6 inches, and an allowable ponding depth of 3 inches. Evaluate if the proposed rain garden design satisfies site WQv requirements

Step 1: Calculate water quality volume using the following equation:

$$WQv = \frac{(P)(Rv)A}{12}$$

where:

P = 90% rainfall number = 0.9 in

Rv = 0.05+0.009 (I) = 0.05+0.009(100) = 0.95

I = Percentage impervious area draining to site = 100%

A = Area draining to practice (treatment area) = 1,000 ft²

$$WQv = \frac{(0.90)(0.95)1,000}{12} \quad WQv = 71.25 \text{ ft}^3$$

Step 2: Solve for drainage layer and soil media storage volume:

$$V_{SM} = A_{RG} \times D_{SM} \times P_{SM}$$

$$V_{DL} = A_{RG} \times D_{DL} \times P_{DL}$$

where:

A_{RG} = proposed rain garden surface area = 200 ft²

D_{SM} = depth soil media = 12 inches = 1.0 ft

D_{DL} = depth drainage layer = 6 inches = 0.5 ft

P_{SM} = porosity of soil media = 0.20

P_{DL} = porosity of drainage layer = 0.40

$$V_{SM} = 200 \text{ ft}^2 \times 1.0 \text{ ft} \times 0.20 = 40 \text{ ft}^3$$

$$V_{DL} = 200 \text{ ft}^2 \times 0.5 \text{ ft} \times 0.40 = 40 \text{ ft}^3$$

D_P = ponding depth = 3 inches = 0.25 ft

$$WQv \leq V_{SM} + V_{DL} + (D_P \times A_{RG}) = 40 \text{ ft}^3 + 40 \text{ ft}^3 + (0.25 \text{ ft} \times 200 \text{ ft}^2)$$

$$WQv = 71.25 \text{ ft}^3 \leq 130.0 \text{ ft}^3, \text{ OK}$$

Therefore, the proposed design for treating an area of 1,000 ft² exceeds the WQv requirements. Since this is a contained rain garden without underdrains, the full WQv for the contributing drainage area (71.25 ft³) is credited towards the runoff reduction volume (Step 3)

New York State Stormwater Management Design Manual

Chapter 5: Green Infrastructure Practices

Section 5.3 Green Infrastructure Techniques

Construction Rain gardens should initially be dug out to a 24” depth, then backfilled with a 6-12 inch layer of clean washed gravel (approximately 1.5-2.0 inch diameter rock), and filled back to the rain garden bed depth with the design soil mix. When an underdrain is used, excavate to 30-36” depth, backfill with 12” stone, fill with 18-24” design soil mix. Rain gardens should only be installed when surrounding landscapes are stabilized and not subject to erosion.

Environmental/Landscaping Elements

The rain garden system relies on a successful native plant community to stabilize the ponding area, promote infiltration, and uptake pollutants. To do that, plant species need to be selected that are adaptable to the wet/dry conditions that will be present. The goal of planting the rain garden is to establish an attractive planting bed with a mix of upland and wetland native shrubs, grasses and herbaceous plant material arranged in a natural configuration starting from the more upland species at the outermost zone of the system to more wetland species at the innermost zone. Plants shall be container-grown with a well-established root system, planted on one-foot centers. Table 5.11 provides a representative list of suggested plant selections. Rain gardens shall not be seeded as this takes too long to establish the desired root system, and seed may be floated out with rain events. The same limitation is true for plugs. Shredded hardwood mulch should be applied up to 2” to help keep soil in place.

New York State Stormwater Management Design Manual

Chapter 5: Green Infrastructure Practices

Section 5.3 Green Infrastructure Techniques

| Table 5.11 Suggested Rain Garden Plant List | |
|---|---|
| Shrubs | Herbaceous Plants |
| Witch Hazel <i>Hamamelis virginiana</i> | Cinnamon Fern <i>Osmunda cinnamomea</i> |
| Winterberry <i>Ilex verticillata</i> | Cutleaf Coneflower <i>Rudbeckia laciniata</i> |
| Arrowwood <i>Viburnum dentatum</i> | Woolgrass <i>Scirpus cyperinus</i> |
| Brook-side Alder <i>Alnus serrulata</i> | New England Aster <i>Aster novae-angliae</i> |
| Red-Osier Dogwood <i>Cornus stolonifera</i> | Fox Sedge <i>Carex vulpinoidea</i> |
| Sweet Pepperbush <i>Clethra alnifolia</i> | Spotted Joe-Pye Weed <i>Eupatorium maculatum</i> |
| | Switch Grass <i>Panicum virgatum</i> |
| | Great Blue Lobelia <i>Lobelia siphatica</i> |
| | Wild Bergamot <i>Monarda fistulosa</i> |
| | Red Milkweed <i>Asclepias incarnate</i> |
| Adapted from NYSDM Bioretention Specifications, Bannerman, Brooklyn Botanic Garden. | |

Maintenance

Rain gardens are intended to be relatively low maintenance. However, these practices may be subject to sedimentation and invasive plant species which could create maintenance problems. If the recharge ability is lost by accumulation of fine sediment, mosquito breeding may occur. Adequate arrangements for long-term maintenance of these systems and updated inventories of their location are essential for the long-term performance of these practices. Rain gardens should be treated as a component of the landscaping, with routine maintenance specified through a legally binding maintenance agreement. Routine maintenance may include the occasional replacement of plants, mulching, weeding and thinning to maintain the desired appearance. Weeding and watering are essential the first year, and can be minimized with the use of a weed-

New York State Stormwater Management Design Manual

Chapter 5: Green Infrastructure Practices

Section 5.3 Green Infrastructure Techniques

free mulch layer. Studies have found that rain gardens, especially when native plants are used, are well accepted if they appear orderly and well maintained. Homeowners and landscapers must be educated regarding the purpose and maintenance requirements of the rain garden, so the desirable aspects of ponded water are recognized and maintained.

Select lower growing species that stay upright. Keep plants pruned if they start to get “leggy” and floppy. Cut off old flower heads after a plant is done blooming. Keeping the garden weeded is one of the most important tasks, especially in the first couple of years while the native plants are establishing their root systems. Once the rain garden has matured, the garden area should be free of bare areas except where stepping stones are located.

Inspect for sediment accumulations or heavy organic matter where runoff enters the garden and remove as necessary. The top few inches of planting soil should be removed and replaced when water ponds for more than 48 hours. Blockages may cause diversion of flow around the garden. If the garden overflow device is an earthen berm or lip, check for erosion and repair as soon as possible. If this continues, a harder armoring of stone may be necessary. Make sure all appropriate elevations have been maintained, no settlement has occurred and no low spots have been created.

References/Further Resources

Bannerman, Roger. 2003. Rain Gardens, a How-to Manual for Homeowners. University of Wisconsin. PUB-WT-776.

Brooklyn Botanic Garden. 2004. Using Spectacular Wetland Plantings to Reduce Runoff.

Iowa Rain Garden Design and Installation Manual, 2008 www.iowastormwater.org

Low Impact Development Center, Inc. (LID) <http://www.lid-stormwater.net/intro/sitemap.htm#permpavers>

Pennsylvania Stormwater Best Management Practices Manual. Draft 2005.

Rain Gardens, A hoe-to manual for homeowners, Wisconsin department of Natural Resources DNR Publication PUB-WT-776 2003.

5.3.8 Green Roofs

Description: Green roofs consist of a layer of vegetation and soil installed on top of a conventional flat or sloped roof (Figure 5.45). The rooftop vegetation captures rainwater allowing evaporation and evapotranspiration processes to reduce the amount of runoff entering downstream systems, effectively reducing stormwater runoff volumes and attenuating peak flows. Green roof designs are characterized as *extensive* or *intensive*, depending on storage depth. *Extensive* green roofs have a thin soil layer and are lighter, less expensive and generally require low maintenance. *Intensive* green roofs often have pedestrian access and are characterized by a deeper soil layer with greater weight, higher capital cost, increased plant diversity and more maintenance requirements.

The general components of any green roof system include:

- a roof structure capable of supporting the weight of a green roof system
- a waterproofing barrier layer designed to protect the building and roof structure
- a drainage layer consisting of a porous media capable of water storage for plant uptake and storm buffering
- a geosynthetic layer to prevent fine soil media from clogging the porous media soil with appropriate characteristics to support selected green roof plants
- plants with appropriate tolerance for regional climate variation, harsh rooftop conditions and shallow rooting depths

Figure 5.44 Green roof installed on a sloped roof, Tupper Lake, NY



http://www.fcwc.org/WEArchive/010203_wbj/rain.htm

See Figure 5.46 for a schematic of the various layers included in a typical green roof system.

Recommended Application of Practice

Green roofs are suitable for retrofit or redevelopment projects as well as new buildings, and can be installed on small garages or larger industrial, commercial and municipal buildings. Green roofs present an above-ground management alternative when on-site space for stormwater practices is limited. Green roofs can be installed on flat roofs or on roofs with slopes up to 30% provided special strapping and erosion control

New York State Stormwater Management Design Manual

Chapter 5: Green Infrastructure Practices

Section 5.3 Green Infrastructure Techniques

devices are used (Peck and Kuhn, 2003).

Generally, extensive green roofs can be built on flat or sloped roofs; whereas intensive systems are built on flat or tiered roofs.

Green roofs are most effective in reducing runoff volume and rates for land uses with high percentages of rooftop coverage such as commercial, industrial and multifamily housing (Stephens *et al.*, 2002). Green roofs on lots with approximately 70% impervious area have been shown to retain as much as 80% of the total annual runoff in regions with low total annual rainfall and 30% in areas with high total annual rainfall (Stephens *et al.*, 2002), which encompasses the range of performance likely to be observed in New York State.

Benefits

Green roofs reduce runoff volumes and delay peak flows while providing a number of other benefits to the urban environment, private building owners, and the public. If roof runoff is at least partly controlled at the source, the size of other BMPs throughout the site can be reduced. The most notable include:

- Green roofs help achieve stormwater management goals by reducing total annual runoff volumes (Roofscapes, Inc., 2005).
- The layers of soil and vegetation on the rooftop moderate interior building temperatures and provide insulation from the heat and cold. This reduces the amount of energy required to heat and cool the building, providing energy savings to the owner. The increased insulation reduces HVAC infrastructure requirements and therefore building construction costs.
- The additional rooftop insulation protects rooftop materials from ultraviolet radiation and extreme temperature

Figure 5.45 Green roof layers

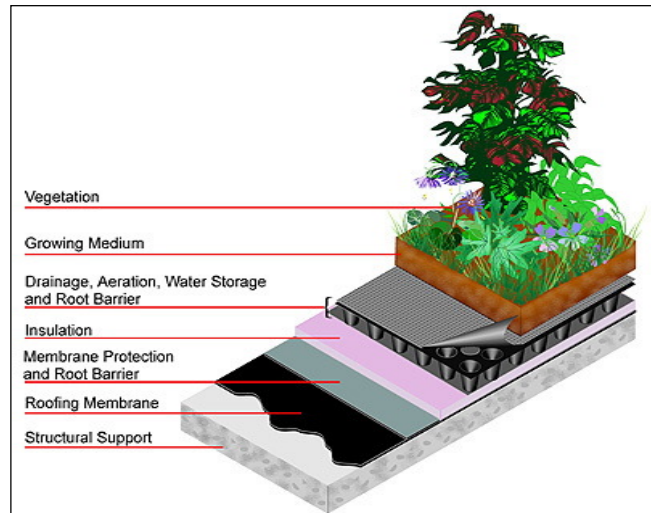

<http://www.uwm.edu/Dept/GLWI/ecoli/Greenroof/images/greenroofcom.jpg>

Figure 5.46 Green roof on a Manhattan apartment building along the Hudson River



Photo courtesy of César Pelli & Associates

New York State Stormwater Management Design Manual

Chapter 5: Green Infrastructure Practices

Section 5.3 Green Infrastructure Techniques

fluctuations, which deteriorates standard roofing materials. It is estimated that green roofs can extend the life of a standard roof by as long as 20 years (Velazquez, 2005).

- Green roofs can be designed to insulate the building interior from outside noise, and sound-absorbing properties of green roof infrastructure can make surrounding areas quieter.
- Fully saturated green roofs provide fire resistance and inhibit the spread of fire from adjacent buildings.
- Green roofs reduce the urban heat island effect by cooling and humidifying the surrounding air.
- Green roofs help filter and bind airborne dust and other particulates, improving air quality (Barr Engineering Company, 2003).
- The additional rooftop vegetation within an urban or suburban environment creates habitat for birds and butterflies.
- With thoughtful design, green roofs can be aesthetically pleasing and improve views from neighboring buildings as illustrated in Figure 5.47, a high-rise residential building in Manhattan.
- A benefit specific to intensive green roofs is pedestrian access to a scenic space within an urban environment, as illustrated in Figure 5.48.

Figure 5.47 Green roof: High Line Park, NYC

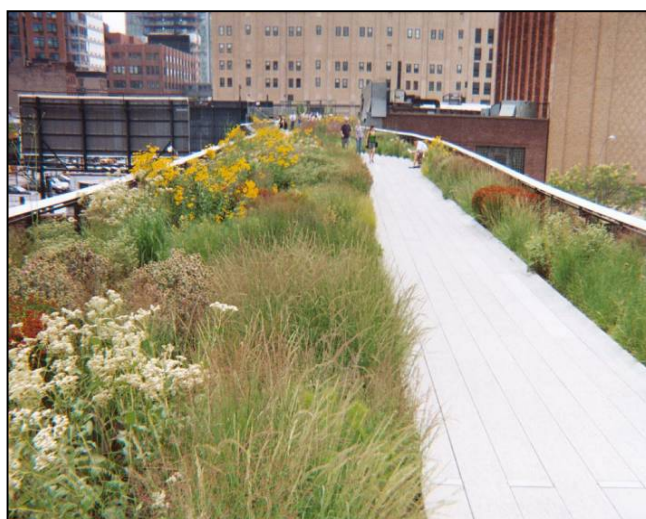

Feasibility/Limitations

The primary limitation to the implementation of green roofs is increased design and construction costs. Green roof designs need to include any structural requirements necessary to support the additional weight of soil, vegetation, and possibly pedestrians. For retrofit projects, a licensed structural engineer or architect must conduct a structural analysis for retrofit of the existing structures, which will dictate the type of green rooftop system and any necessary structural reinforcement. Other limitations include:

- Damage to or failure of waterproofing elements present a risk of causing water damage. However, as with traditional roof installations, a warranty can help guarantee that any damage to the water proofing system will be repaired.
- Extreme weather conditions can impact plant survival.
- Green roof maintenance is higher than that for traditional roofs.
- Safe access to the rooftop should be provided for construction and maintenance.

New York State Stormwater Management Design Manual

Chapter 5: Green Infrastructure Practices

Section 5.3 Green Infrastructure Techniques

- Supplemental irrigation during the first year may be necessary to establish vegetation, and a long-term supplemental irrigation system may be required for some intensive systems.
- In cold climates, snow loads need to be accounted for in determining the structural capacity required to install a green roof system.
- In many building designs it will likely be more feasible to incorporate an extensive green roof design versus an intensive system.

Sizing and Design Criteria

Stormwater treatment in green roofs occurs via evaporation, transpiration, and filtration. The green roof area is pervious and so can be applied towards meeting the total impervious cover reduction target to address water quality volume in redevelopment sites. The green roof area can be used as either an impervious area reduction or a volume reduction, but not both. For new development, the water quality volume for the green roof is applied towards the runoff reduction volume, provided that the storage provided within the roof structure is equal to or greater than the calculated WQv. Stormwater storage volume sizing calculations are outlined below. The storage media depth can be adjusted so the media storage is equivalent to the New York Unified Stormwater Sizing Criteria for water quality volume or the excess storage volume may be used to temporarily store all or some of the one year storm to meet the Channel Protection requirements.

$$\text{Storage Volume} = V_{SM} + V_{DL} + (D_P \times A_{GR})$$

$$V_{SM} = A_{GR} \times D_{SM} \times n_{SM}$$

$$V_{DL} = A_{GR} \times D_{DL} \times n_{DL}$$

where:

V_{SM} = volume of the soil media [cubic feet]

V_{DL} = volume of the drainage layer [cubic feet]

A_{GR} = green roof surface area [square feet]

D_{SM} = depth of the soil media [0.25 to 0.5 feet for extensive; 0.5 to 2.0 feet for intensive]

D_{DL} = depth of the drainage layer [feet]

D_P = depth of ponding above surface [feet]

n_{SM} = porosity of the soil media (~20%)

n_{DL} = porosity of the drainage layer (~25%)

WQv = Water Quality Volume [cubic feet], as defined in Chapter 4 of the NYSDM

A simple example for sizing green roofs based on WQv is presented in Table 5.12 below:

New York State Stormwater Management Design Manual

Chapter 5: Green Infrastructure Practices

Section 5.3 Green Infrastructure Techniques

Table 5.12 Simple Green Roof Sizing Example

A green roof has been designed for a 1,100 square foot rooftop. The proposed system has a 900 sq ft surface area, a 3 inch soil media layer, and a 2 inch drainage layer. Given the proposed design, evaluate if the proposed green roof design satisfies site WQv requirements:

Step 1: Calculate water quality volume using the following equation:

$$WQv = \frac{(P)(Rv)A}{12}$$

where:

P = 90% rainfall number = 0.9 in

Rv = 0.05+0.009 (I) = 0.05+0.009(100) = 0.95

I = the percentage of impervious area draining to site = 100%

A = area draining to practice = 1,100 ft²

$$WQv = \frac{(0.90)(0.95)1,100}{12}$$

$$WQv = 78.4 \text{ ft}^3$$

Step 2: Calculate the drainage layer and soil media storage volume:

$$V_{SM} = A_{GR} \times D_{SM} \times P_{SM}$$

$$V_{DL} = A_{GR} \times D_{DL} \times P_{DL}$$

where:

A_{GR} = green roof surface area = 900 ft²

D_{SM} = depth soil media = 3 inches = 0.25 ft

D_{DL} = depth drainage layer = 2 inches = 0.17 ft

P_{SM} = porosity of soil media = 0.20

P_{DL} = porosity of drainage layer = 0.25

V_{SM} = 900 ft² x 0.25 ft x 0.20 = 45.0 ft³

V_{DL} = 900 ft² x 0.17 ft x 0.25 = 38.25 ft³

D_P = ponding depth = 0.5 inches = 0.04 ft

Storage Volume = V_{SM}+V_{DL}+(D_P x A_{GR}) = 45.0 ft³ + 38.25 ft³ + (0.04 ft x 900 ft²)=119.25

$$WQv = 78.4 \text{ ft}^3 < 119.25 \text{ ft}^3$$

Therefore, the proposed design satisfies the WQv storage requirements. The extra storage volume provided within the green roof can be used to treat small impervious areas immediately adjacent to the roof (such as walkways, skylights, etc...) or for storage of the Channel Protection storm. The WQv of 78.4 ft³ is applied towards the runoff reduction volume.

Figure 5.49 Extensive cross-section

Required Elements

Each green roof project is unique, given the purpose of the building, its architecture and the preferences of its owner and end user. However, several key design features should be kept in mind during the design of any green rooftop systems.

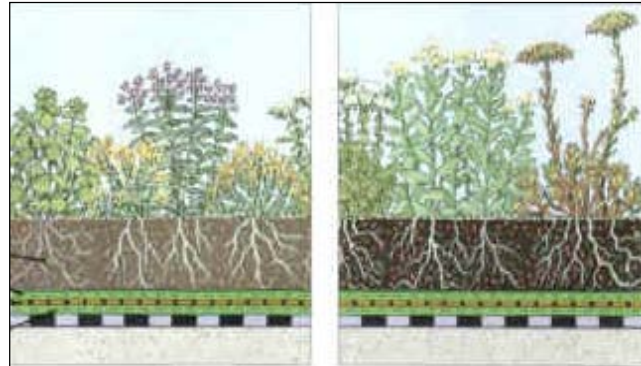

Extensive systems are characterized by low weight, lower capital cost, and minimal plant diversity (Figure 5.49). The growing medium is usually a mixture of sand, gravel, crushed brick, peat, or organic matter combined with soil. The soil media ranges between three and six inches in depth and increases the roof load by 16 to 50 pounds per square foot when fully saturated. Since the growing medium is shallow and the microclimate is harsh, plant species used in extensive systems should be low and hardy, which typically involves alpine, arid, or indigenous species.

Intensive systems have a deeper soil layer and a corresponding greater weight (Figure 5.50). The growing medium is often soil based and ranges in depth from six to 24 inches, with a saturated roof loading of between 50 and 200 pounds per square foot. Designers can use a diverse range of trees, shrubs and groundcover because the deeper growing medium allows longer root systems. This allows the designer to develop a more complex ecosystem. Both a structural engineer and an experienced installer are required for design and installation of intensive systems

Figure 5.48 Intensive cross-section

The five principal components of any green roof system are roof structure, waterproofing, drainage system, soil media and planting types. General design guidelines for each of these components are described below.

Roof Structure: The load bearing capacity of the roof structure is critical for the support of soil, plants, and any people who will be accessing the green roof (for either maintenance or recreation). Generally, green roofs weighing more than 17 pounds per square foot (saturated) require consultation with a structural engineer (Barr Engineering, 2003). As a fire resistance measure, non-vegetative materials, such as stone or pavers should be installed

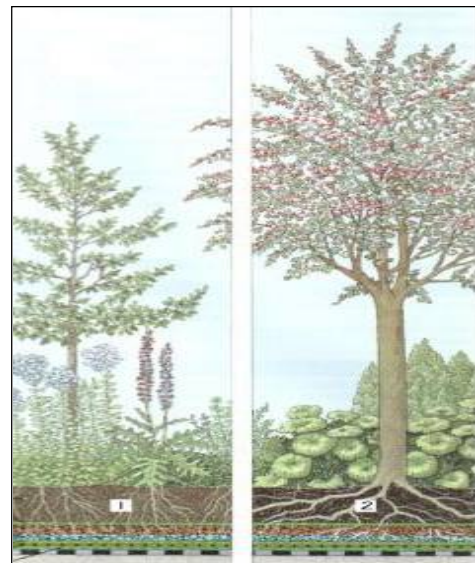

New York State Stormwater Management Design Manual

Chapter 5: Green Infrastructure Practices

Section 5.3 Green Infrastructure Techniques

around all rooftop openings and at the base of all walls that contain openings (Barr Engineering, 2003). On sloped roofs additional erosion control measures, such as cross-battens, may be necessary to stabilize drainage layers.

Waterproofing: In a green roof system the first layer above the roof surface is a waterproofing membrane. Two common waterproofing techniques used for the construction of green roofs are monolithic and thermoplastic sheet membranes. An additional protective layer is generally placed on top of either of these membranes followed by a physical or chemical root barrier. Once the waterproofing system has been installed it should be fully tested prior to construction of the drainage system.

Drainage System: The drainage system includes a porous drainage layer and a geosynthetic filter mat to prevent fine soil particles from clogging the porous media. The drainage layer can be made up of gravels or recycled-polyethylene materials that are capable of water retention and efficient drainage. The depth of the drainage layer depends on the load bearing capacity of the roof structure and the stormwater retention requirements. Once the porous media is saturated excess water should be directed to a traditional rooftop storm drain system. The porosity of the drainage system should be greater than or equal to 25% (Cahill Associates, 2005).

Soil: The soil layer above the drainage system is the growing media for the plants in a green roof system. Soils used in green roofs are generally lighter than standard soil mixes, and consist of 75% mineral and 25% organic material (Barr Engineering, 2003), and no clay size particles. The chemical characteristics of the soil (e.g., pH, nutrients, etc.) should be carefully selected in consideration with the planting plan. The porosity of the soil layer, measured as non-capillary pore space at field capacity, should be greater than or equal to 15% (Cahill Associates, 2005).

Planting Types

Plant selection for green rooftops is governed by local climate and design objectives. The range of plants suitable for roof landscapes is limited by the extremes of the rooftop microclimate including high wind, drought and low winter temperatures. A qualified botanist or landscape architect should be consulted when choosing plant material. For extensive systems, plant material should be confined to hardier or indigenous varieties of grass and sedum. Root size and depth should also be considered to ensure that the plants stabilize the shallow depth of soil media. Plant choices can be much more diverse for intensive systems. The height of the roof, its exposure to wind, snow loading potential, its orientation to the sun and shading by surrounding buildings all have an impact on the selection of appropriate vegetation. Several years are required for a green

New York State Stormwater Management Design Manual

Chapter 5: Green Infrastructure Practices

Section 5.3 Green Infrastructure Techniques

roof to reach its optimum performance (Cahill Associates, 2005 - Draft Pennsylvania Stormwater Management Manual). Plantings such as the following may be considered for New York State temperate zones:

- [Allium schoenoprasum](#)
- [Sedum acre 'Aureum'](#)
- [Sedum album](#)
- [Sedum album 'Murale'](#)
- [Sedum floriferum 'Weihenstephaner Gold'](#)
- [Sedum kamtschaticum](#)
- [Sedum reflexum](#)
- [Sedum sexangulare](#)
- [Sedum spurium 'Fuldaglut'](#)
- [Sedum spurium 'John Creech'](#)
- [Sedum spurium 'Roseum'](#)
- [Sedum spurium 'White Form'](#)
- [Talinum calycinum](#)

Maintenance

Green roof maintenance may include watering, fertilizing and weeding and is typically greatest in the first two years as plants become established. Roof drains should be cleared when soil substrate, vegetation or debris clog the drain inlet. Maintenance largely depends on the type of green roof system installed and the type of vegetation planted. Maintenance requirements in intensive systems are generally more costly and continuous, compared to extensive systems. The use of native vegetation is recommended to reduce plant maintenance in both extensive and intensive systems.

A green roof should be monitored after completion for plant establishment, leaks and other functional or structural concerns. Vegetation should be monitored for establishment and viability, particularly in the first two years. Irrigation and fertilization is typically only a consideration during the first year before plants are established. After the first year, maintenance consists of two visits per year for weeding of invasive species, and safety and membrane inspections (Magco, 2003).

New York State Stormwater Management Design Manual

Chapter 5: Green Infrastructure Practices

Section 5.3 Green Infrastructure Techniques

References/Further Resources

ASTM E2396 - 05 Standard Test Method for Saturated Water Permeability of Granular Drainage Media [Falling-Head Method] for Green Roof Systems

ASTM E2397 - 05 Standard Practice for Determination of Dead Loads and Live Loads associated with Green Roof Systems.

ASTM E2398 - 05 Standard Test Method for Water Capture and Media Retention of Geocomposite Drain Layers for Green Roof Systems

ASTM E2399 - 05 Standard Test Method for Maximum Media Density for Dead Load Analysis of Green Roof Systems (includes tests to measure moisture retention potential and saturated water permeability of media).

ASTM E2400 - 06 Standard Guide for Selection, Installation, and Maintenance of Plants for Green Roof

ASTM E631 - 06 Standard Terminology of Building Constructions

ASTM C29 / C29M - 07 Standard Test Method for Bulk Density ("Unit Weight") and Voids in Aggregate

ASTM E2114 - 08 Standard Terminology for Sustainability Relative to the Performance of Buildings

ASTM WK7319 - New Standard Guide for Use of Expanded Shale, Clay or Slate (ESCS) as a Mineral Component in Growing Media for Green Roof Systems (std. still in development as of June 2009).

Barr Engineering Company. 2003. Minnesota Urban Small Sites BMP Manual: Stormwater Best Management Practices for Cold Climates. Metropolitan Council Environmental Services. St. Paul, Minnesota. <http://www.metrocouncil.org/environment/Watershed/bmp/manual.htm>

Cahill Associates, Inc. January 2005. Draft Pennsylvania Stormwater Best Management Practices Manual, Department of Environmental Protection, Bureau of Stormwater Management, and Division of Waterways, Wetlands, and Erosion Control.

City of Chicago. Accessed 2005. *Guide to Rooftop Gardening*
http://egov.cityofchicago.org/webportal/COCWebPortal/COC_ATTACH/GuidetoRooftopGardening_v2.pdf

City of Portland. 2000. *Stormwater Management Manual*. City of Portland. Portland, Oregon.

Flinker, P., 2005. Rhode Island Urban Environmental Design Manual "Green Rooftop Systems" Narrative. Sustainable Watersheds Office Rhode Island Department of Environmental Management.
<http://www.dem.ri.gov/programs/bpoladm/suswshed/pubs.htm>

Liptan, T. and E. Strecker. 2003. *Ecoroofs – A More Sustainable Infrastructure*. Presented at Urban Stormwater: Enhancing Programs at the Local Level. February 17-20, 2003. Cosponsored by US EPA, Chicago Botanic Gardens and Conservation Technology Information Center. Chicago, Illinois.

New York State Stormwater Management Design Manual

Chapter 5: Green Infrastructure Practices

Section 5.3 Green Infrastructure Techniques

Magco, Inc. Accessed 2003. Intensive and Extensive Green Roofs.
http://www.magco.com/extensive_intensive.html

Maryland Department of the Environment. Green Roof - Fact Sheet. Maryland's Stormwater Management Manual. http://www.mde.state.md.us/assets/document/sedimentStormwater/SWM_greenroof.pdf

Peck, S. and M. Kuhn. Accessed 2003. *Design Guidelines for Green Roofs*. http://www.cmhc-schl.gc.ca/en/imquaf/himu/himu_002.cfm

Roofscapes, Inc. Accessed 2005. Green Technology for the Urban Environment. www.roofmeadow.com.

Snodgrass, E. Accessed 2003. <http://www.greenroofplants.com/>

Stephens, K. A., Graham, P. and D. Reid. 2002. *Stormwater Planning: A Guidebook for British Columbia*. British Columbia Ministry of Water, Land and Air Protection.

The Cardinal Group, Inc. Accessed 2002. www.greenroofs.ca.

Velazquez, L. S. 2005. *Greenroofs.com*. <http://www.greenroofs.com>

5.3.9 Stormwater Planters

Description: Stormwater planters are small landscaped stormwater treatment devices that can be placed above or below ground and can be designed as infiltration or filtering practices. Stormwater planters use soil infiltration and biogeochemical processes to decrease stormwater quantity and improve water quality, similar to rain gardens and green roofs. Three versions of stormwater planters include contained planters, infiltration planters, and flow-through planters.

A contained planter is essentially a potted plant placed above an impervious surface (Figure 5.51). Stormwater infiltrates through the soil media within the container, and overflows when the void space or infiltration capacity of the container is exceeded.

An infiltration planter is a contained planter with a pervious bottom that allows stormwater to infiltrate through the soil media within the planter and pass into the underlying soil matrix (Figure 5.52). A flow-through planter is a contained planter

Figure 5.50 Contained storm water planter

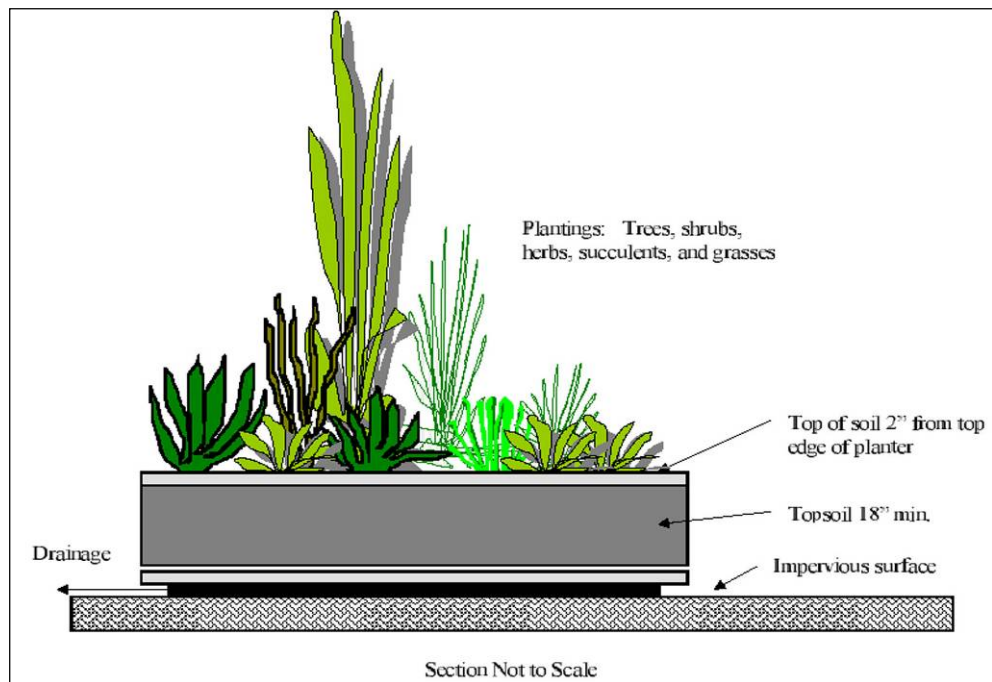

with an under drain system that conducts filtered stormwater to the storm drain system or downstream waterway (Figure 5.53).

All three types of stormwater planters include three common elements: planter “box” material (e.g., wood or concrete); growing medium consisting of organic soil media; and vegetation. Infiltration and flow-through planters may also include splash rock, filter fabric, gravel drainage layer, and perforated pipe.

Recommended Application of the Practice

Figure 5.51 Infiltration stormwater planter

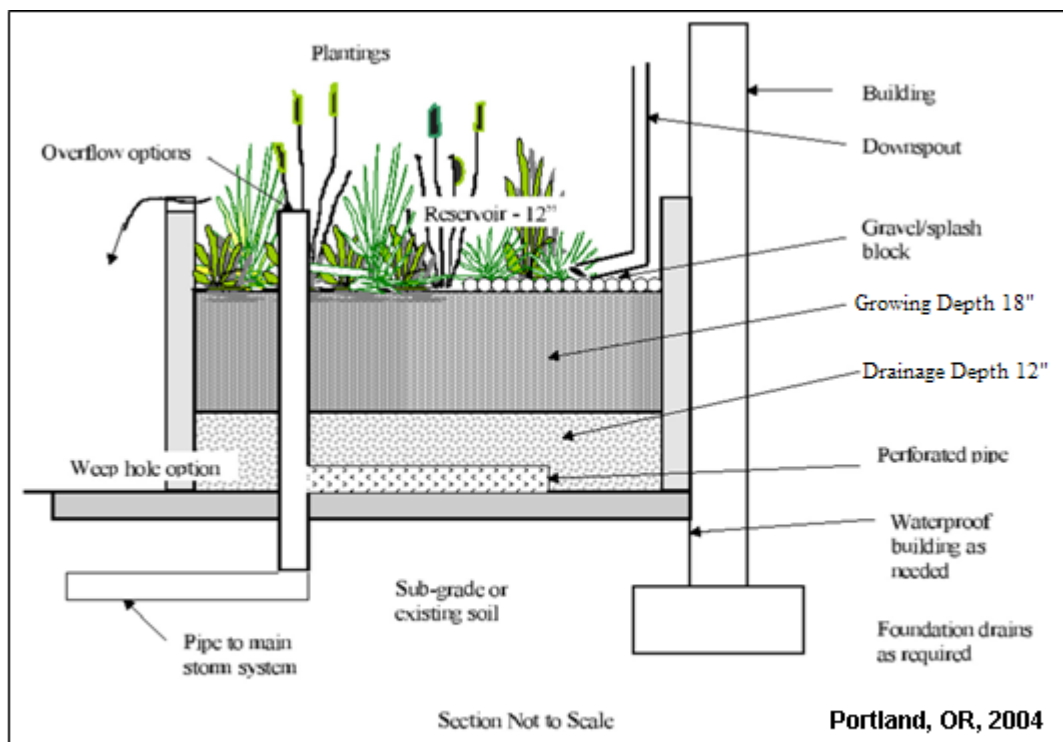

The versatility of stormwater planters makes them uniquely suited for urban redevelopment sites. Depending on the type, they can be placed adjacent to buildings, on terraces or rooftops. Building downspouts can be placed directly into infiltration or flow-through planters; whereas contained planters are designed to capture rainwater, essentially decreasing the site impervious area. The infiltration and adsorption properties of stormwater planters make them well suited to treat common pollutants found in rooftop runoff, such as nutrients, sediment and dust, and bacteria found in bird feces. Stormwater planters are most effective at treating small storm events because of their comparatively small individual treatment capacity.

Benefits

Stormwater planters provide many stormwater management benefits, among them:

- If on-site soils or a high seasonal groundwater table are not suitable for infiltration practices (e.g. rain garden or infiltration trench), flow-through or contained stormwater planters make filtration treatment possible.
- Stormwater planters can reduce stormwater volumes and velocities discharging from treated impervious areas.

Figure 5.52 Flow-through stormwater planter

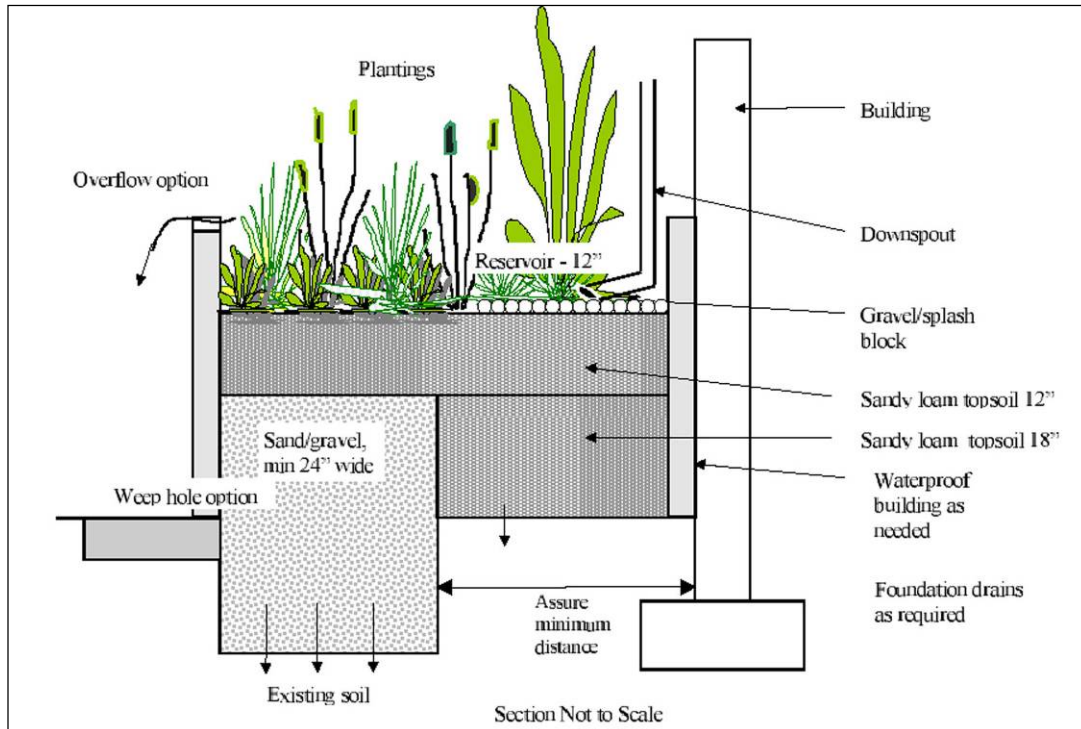

- Flow-through or contained planters do not require a setback from a building foundation, though appropriate waterproofing technology should be incorporated into the design.
- Planters create an aesthetic landscape element, as well as providing micro-habitat within an urban environment.

Feasibility/Limitations

The primary limitation to the use of stormwater planters is their size. They are by definition small-scale stormwater treatment cells that are not well suited to treat runoff from large storm events, or large surface areas. They can, however, be used in series or to augment other stormwater management practices. Other limitations include:

- Stormwater planters are not designed to treat runoff from roadways or parking lots but are ideally suited for treating rooftop or courtyard/plaza runoff.
- Flow-through and infiltration stormwater planters should not receive drainage from impervious areas greater than 15,000 square feet.
- For all three types of stormwater planters, if the infiltration capacity of the soil is exceeded, the planter will overflow. Excess stormwater needs to be directed to a secondary treatment system or released untreated to the storm drain system.

Sizing and Design Criteria

New York State Stormwater Management Design Manual

Chapter 5: Green Infrastructure Practices

Section 5.3 Green Infrastructure Techniques

Stormwater planters should initially be sized to satisfy the WQv requirements for the impervious surface area draining to the practice. This does not apply to contained planters because they are designed to decrease impervious area, not receive additional runoff from adjacent surfaces. The basis for the sizing guidance is the same as that for bioretention (see Chapter 6 of the New York Stormwater Management Design Manual) and relies on the principles of Darcy's Law, where water is passed through porous media with a given head, a given hydraulic conductivity, over a given timeframe (Flinker, 2005). The equation for sizing an infiltration or flow-through stormwater planter based upon the contributing area is as follows:

$$A_f = WQv \times (d_f) / [k \times (h_f + d_f)(t_f)]$$

where:

A_f = the required surface area [square feet]

WQv = water quality volume [cubic feet], as defined in Chapter 4 of this Design Manual

d_f = depth of the soil medium [feet]

k = the hydraulic conductivity [ft/day], usually set at 4 ft/day when soil is loosely placed in the planter, but can be varied depending on the properties of the soil media. Some other reported conductivity values are:

Sand: 3.5 ft/day (City of Austin 1988).

Peat: 2.0 ft/day (Galli 1990).

Leaf compost: 8.7 ft/day (Clayton and Schueler, 1996).

Bioretention Soil: 0.5 ft/day (Clayton and Schueler, 1996).

h_f = average height of water above the planter bed [≤ 6 inches for a maximum ponding depth of 12 inches]

t_f = the design time to filter the treatment volume through the filter media [usually set at 3 to 4 hours]

Required Elements

There are a number of sizing, siting, and material specification guidelines that should be consulted during stormwater planter design.

SITING

- Flow-through and infiltration stormwater planters should not receive drainage from impervious areas greater than 15,000 square feet.
- Infiltration planters should be located a minimum distance of ten feet from structures.
- To prevent erosion, splash rocks should be placed below downspouts or where stormwater enters the planter.

New York State Stormwater Management Design Manual

Chapter 5: Green Infrastructure Practices

Section 5.3 Green Infrastructure Techniques

SIZING

- Stormwater planters should be designed to pond water for less than 12 hours, with a maximum ponding depth of 12 inches.
- An overflow control should redirect high flows to the storm drain system or an alternative treatment facility.
- Generally, flow-through and infiltration planters should have a minimum width of 1.5 and 2.5 feet, respectively.

SOIL

- Soil specifications for the stormwater planter growing medium should allow an infiltration rate of 2 inches per hour, and 5 inches an hour for the drainage layer.
- Soil compaction must be no greater than 85% in the planter.
- The growing medium depth for all three stormwater planter types should be at least 18 inches. Growing media should be a uniform mixture of 70% sand (100% passing the 1-inch sieve and 5% passing the No. 200 sieve) and 30% topsoil with an average of 5% organic material, such as compost or peat, free of stones, roots and woody debris and animal waste.
- For infiltration and flow-through planters the drainage layer should have a minimum depth of 12 inches. Drainage layer should be clean sand with 100% passing the 1-inch sieve and 5% passing the No. 200 sieve.

SPECIFIC CONSIDERATIONS FOR THE DESIGN OF INFILTRATION PLANTERS

- The infiltration rate of the native soil should be a minimum of 2 inches per hour.
- A minimum infiltration depth of 3 feet should be provided between the bottom of the infiltration practice and any impermeable boundaries, such as the seasonal high groundwater level or rock.
- Infiltration planters should also be designed and constructed with no longitudinal or lateral slope.

Figure 5.53 Contained stormwater planters made of concrete



New York State Stormwater Management Design Manual

Chapter 5: Green Infrastructure Practices

Section 5.3 Green Infrastructure Techniques

CONSTRUCTION

Figure 5.54 This flow-through planter collects runoff from the rooftop of a parking garage and is incorporated into the structure

- Materials suitable for planter wall construction include stone, concrete, brick, clay, plastic, wood, or other durable material (Figure 5.54).
- Treated wood may leach toxic chemicals and contaminate stormwater, and should not be used.
- Flow-through planter walls can be incorporated into a building foundation, with detailed specifications for planter waterproofing (Figure 5.55).



<http://www.lcrep.org/fieldguide/examples/containedpl>

Example

A simple example for sizing a stormwater planter using WQ_v is presented below. The ultimate size of a stormwater planter is a function of either the impervious area or the infiltration capacity of the media.

Determine the required surface area of a stormwater planter that will be installed to treat stormwater runoff from an impervious area of 3,000 square feet, given the depth of the soil medium is 1.5 feet.

Step 1: Calculate the WQ_v

$$WQ_v = (P) (R_v) (A) / 12$$

where:

$$P = 90\% \text{ rainfall number} = 0.9 \text{ in}$$

$$R_v = 0.05 + 0.009 (I) = 0.05 + 0.009(100) = 0.95$$

$$I = \text{percentage impervious area draining to planter} = 100\%$$

$$A = \text{Area draining to practice} = 3,000 \text{ ft}^2$$

$$WQ_v = (0.9) (0.95) (3000) / 12$$

$$WQ_v = 213.75 \text{ ft}^3$$

Step 2: Calculate required surface area:

$$A_f = WQ_v * (d_f) / [k * (h_f + d_f) (t_f)]$$

New York State Stormwater Management Design Manual

Chapter 5: Green Infrastructure Practices

Section 5.3 Green Infrastructure Techniques

where:

$$WQ_v = 213.75 \text{ ft}^3$$

$$d_f = \text{depth of soil medium} = 1.5 \text{ ft}$$

$$k = \text{hydraulic conductivity} = 4 \text{ ft/day}$$

$$h_f = \text{Average height of water above planter bed} = 0.5 \text{ ft}$$

$$t_f = \text{filter time} = 0.17 \text{ days}$$

$$A_f = (213.75)(1.5) / [(4)(0.5+1.5)(0.17)]$$

$$A_f = 235.75 \text{ ft}^2$$

Therefore, a 240 square-foot stormwater planter with a soil medium depth of 1.5 feet will be needed to treat stormwater from a 3,000 square foot area. The calculated WQ_v of 213.75 ft^3 is added to the Runoff Reduction Volume for the site (if the site soils are suitable for infiltration). If the planter is designed as a flow-through planter on C soils, then 96 ft^3 (45% of the WQ_v for the area draining to the planter) is added to the Runoff Reduction Volume. 64 ft^3 (30% of the WQ_v) is added towards the Runoff Reduction Volume for a flow through planter on D soils.

Environmental/Landscaping

Vegetation selected for stormwater planters should be relatively self-sustaining and adaptable. Native plant species are recommended, and fertilizer and pesticide use should be avoided whenever possible. Tree planting is encouraged in and adjacent to infiltration and flow-through planters for the infiltration, habitat and interception benefits they can provide.

Maintenance

A regular and thorough inspection regime is vital to the proper and efficient function of stormwater planters. Debris and trash removal should be conducted on a weekly or monthly basis, depending on likelihood of accumulation. Following construction, planters should be inspected after each storm event greater than 0.5 inches, and at least twice in the first six months. Subsequently, inspections should be conducted seasonally and after storm events equal to or greater than the 1-year storm event. Routine maintenance activities include pruning and replacing dead or dying vegetation, plant thinning, and erosion repair. Since stormwater planters are not typically preceded by pre-treatment practices, the soil surface should be inspected for evidence of sediment build-up from the connected impervious surface and for surface ponding. Attention should be paid to additional seasonal maintenance needs as well as the first growing season.

New York State Stormwater Management Design Manual

Chapter 5: Green Infrastructure Practices

Section 5.3 Green Infrastructure Techniques

References/Further Resources

City of Portland, Oregon. Revised September 2004. Portland Stormwater Management Manual.
<http://www.portlandonline.com/bes/index.cfm?c=35122>

Flinker, P., 2005. Rhode Island Urban Environmental Design Manual “Green Rooftop Systems” Narrative.
Sustainable Watersheds Office Rhode Island Department of Environmental Management.
<http://www.dem.ri.gov/programs/bpoladm/suswshed/pubs.htm>

Low Impact Development Center, Inc. (LID). Accessed 2005. http://www.lid-stormwater.net/treebox/treeboxfilter_cost.htm

New York Floral Association: New York Floral Atlas website: <http://www.newyork.plantatlas.usf.edu/>

Portland Bureau of Environmental Services (PBES). December 2004. Liberty Centre Parking Garage.
<http://www.portlandonline.com/bes/index.cfm?c=38135>

USDA, Natural Resources Conservation Service PLANTS database: <http://plants.usda.gov/>

5.3.10 Rain Barrels and Cisterns

Description: Rain Barrels and Cisterns capture and store stormwater runoff to be used later for lawn and landscaping irrigation or filtered and used for nonpotable water activities such as car washing or filling swimming pools and other uses that have a routine demand for water when in service. Rain Barrels and Cisterns may be constructed of any water-retaining material; their size varies from hundreds of gallons for residential uses to tens of thousands of gallons for commercial and/or industrial uses. The storage systems may be located either above or below ground and may be constructed of on-site material or pre-manufactured. Rain barrels are rooftop catchment storage systems typically utilized in residential settings while cisterns are large-scale rain barrels used in commercial and industrial settings. The basic components of a rain barrel and cistern include: a watertight storage container, secure cover, a debris/mosquito screen, a coarse inlet filter with clean-out valve, an overflow pipe, a manhole or access hatch, a drain for cleaning, an extraction system (tap or pump). Additional features might include a water level indicator, a sediment trap or a connector pipe to an additional tank for extra storage volume. The storage containers are usually placed on riser blocks or a gravel pad to aid in gravity drainage of collected runoff and to prevent the accumulation of overflow water around the system.

Recommended Application of the Practice

Rain Barrels and Cisterns may be used in most areas (residential, commercial, and industrial; see Figure 5.56) due to their minimal site constraints relative to other stormwater management practices. They may be applied to manage almost every land use type from very dense urban to more rural residential areas. Storage volumes of the rain barrels and cisterns are directly proportional to their contributing rooftop drainage areas and the intended end use and demand for the collected rainwater.

Benefits

Rain Barrels and Cisterns provide many stormwater management benefits, including:

- Reduced stormwater runoff entering the drainage system, not only reduced volumes, but also delayed and/or reduced peak runoff flow rates during the water quality storm event.
- Reduced transport of pollutants associated with atmospheric deposition on rooftops into receiving waters, especially heavy metals and other airborne pollutants (USEPA, 2005).
- Reduced water consumption for nonpotable uses, which ultimately reduces the demand on municipal water systems. Water from rain barrels and cisterns, if managed correctly, may be used to water lawns and landscaping , wash automobiles, and top off pools (MEDP, 2009)

New York State Stormwater Management Design Manual

Chapter 5: Green Infrastructure Practices

Section 5.3 Green Infrastructure Techniques

- Use as retrofits in urban redevelopment scenarios to reduce runoff volumes in areas where there is a high percentage of impervious cover, soils are compacted, groundwater levels are high, and/or hot-spot conditions exist that preclude infiltration of runoff.

Figure 5.55 Cisterns can be designed for smaller residential uses (left) or for larger commercial and industrial business operations (right).



Feasibility/Limitations

The biggest limitation to the installation and use of rain barrels and cisterns for the capture and reuse of stormwater is the need for active management/maintenance and initial capital cost. Generally, the ease and efficiency of municipal water supply systems and the low cost of potable water prevent people from implementing on-site rainwater collection and reuse systems. Specific limitations include:

- Periodic maintenance and cleaning to ensure effective storage of stormwater while reducing the growth of algae and limiting the potential for mosquito breeding.
- A supplementary water source may be needed if captured water does not fulfill the intended water demand. Alternatively if captured water is not used as anticipated or excessive rainfall occurs, the extra water collected must be managed to prevent overtopping and erosion of areas below the rain barrel or cistern.
- To achieve significant community wide acceptance, an active community education program and/or a high profile demonstration project at a public facility will likely be necessary.
- Improper or infrequent use of the collection system by the property owner, such as the rain barrel never being emptied between storm events to allow for subsequent capture of rooftop runoff may result in unintended discharges.

New York State Stormwater Management Design Manual

Chapter 5: Green Infrastructure Practices

Section 5.3 Green Infrastructure Techniques

- In cold climates specific design or maintenance strategies will need to be considered to prevent freezing such as providing insulation or disconnecting the system during the winter months.
- Rooftop harvested rainwater has the potential for contamination and should not be used for drinking or watering food plants. Pipes or storage units should be clearly marked. Local health and plumbing codes need to be consulted.
- The conveyance system should keep reused stormwater or grey water from other potable water piping systems. Do not connect to domestic or commercial potable water systems.

Sizing and Design Criteria

The cistern/rain barrel sizing is based on the water demand for the intended use. The amount of water available for reuse is a function of the impervious area that drains to the device. Runoff reduction credit is applied if the water demand and system sizing is equal to or greater than the WQv. A supplementary water source may be needed to augment the cistern/rain barrel system. The basic equation for sizing a system based on the contributing area is as follows:

$$\text{Vol} = \text{WQv} * 7.5 \text{ gals/ ft}^3$$

where:

Vol = Volume of system [gallons]

WQv = Water Quality Volume [ft³], as defined in Chapter 4 of the NYS Stormwater Design Manual

7.5 = Conversion factor [gallons per ft³]

Siting the System

A rain barrel may be located beneath a single downspout or multiple rain barrels may be located such that they collect stormwater from several rooftop sources. Due to the size of rooftops and the amount of contributing impervious area, increased runoff volume and peak discharge rates for commercial and industrial sites may require large capacity cisterns. Rain barrels and Cisterns designed to capture small, frequent storm events must be either actively or passively drained to provide storage for subsequent storm events or located in an area where overflow runoff can be conveyed to a suitable area such as a buffer area, open yard, grass swale or a rain garden. See Figure 5.57.

CLIMATE

Climate is an important consideration and capture/reuse systems should be designed to account for the potential for freezing. In cold climates where cisterns are designed for use throughout the year, they will need to be protected from freezing. These systems may need to be located indoors or underground below

Figure 5. 56 Cross section of a residential rain barrel system with overflow

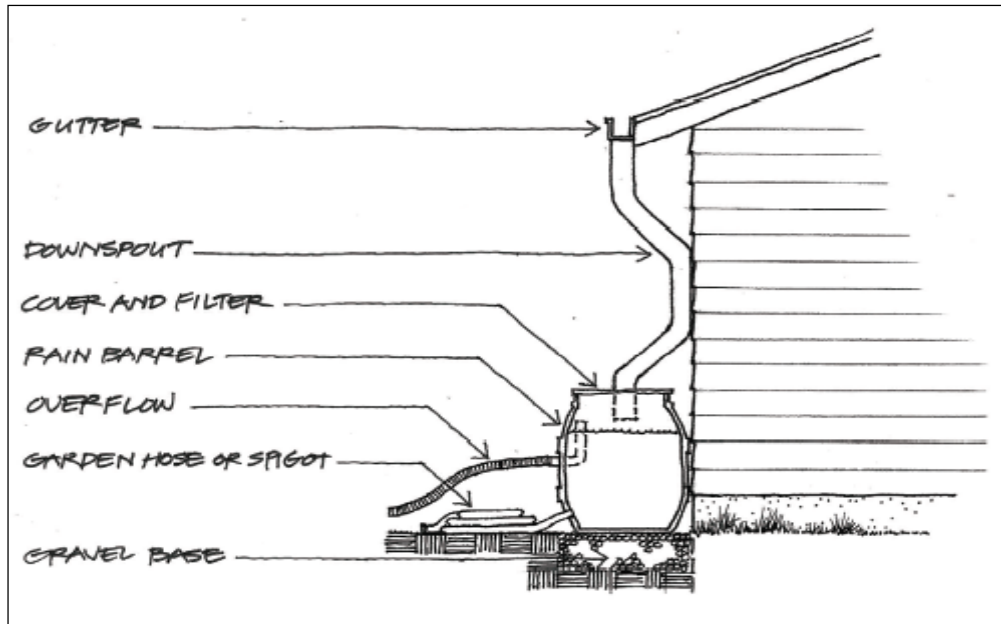

http://buildgreen.ufl.edu/Fact_%20sheet_Cisterns_Rain_Barrels.p

the frost line if freezing conditions are expected. Cisterns placed on the ground require extra insulation on the exposed surfaces (Stensrod, *et al.*, 1989). For cisterns placed on rock, the bottom surface will also need to be insulated. For underground systems it may be cost-prohibitive to place the cistern below the freezing depth, so alternatively, insulation may be placed below the surface and above the underground cistern to prevent freezing. Other methods to prevent freezing include lining the intake pipe and cistern with heat tape and closing the overflow valve (Stensrod, *et al.*, 1989). Water levels in the cistern must be lowered at the beginning of winter to prevent possible winter ice damage and provide the needed storage in the cistern for capturing rooftop runoff from the spring snow melt.

The year round use of rain barrels in cold climates is not recommended since these containers may burst due to ice formation and freezing temperatures (Metropolitan Council, 2001). It is recommended that the rain barrels be disconnected from the roof gutters and placed indoors during the winter months. Downspout piping must be reconnected and directed to a grassy area away from the structure to prevent winter snowmelt from damaging building foundations.

Design Example

A simple example for sizing cisterns using WQv is presented in Table 5.13.

New York State Stormwater Management Design Manual

Chapter 5: Green Infrastructure Practices

Section 5.3 Green Infrastructure Techniques

Though at a minimum the WQv must be stored in the rain barrel or cistern to earn runoff reduction credit for this practice, the amount of storage provided by the system determines the volume of water available for reuse. As a rule of thumb, a 1,000 S.F. roof will generate 625 gallons of rain during a 1” storm event.

Table 5.13 Simple Cistern Sizing Example

Given a 3,000 square foot impervious surface area draining to a cistern, calculate the water quality volume and required storage volume within the system.

Step 1: Calculate water quality volume using the following equation:

$$WQv = \frac{(P)(Rv)A}{12}$$

where:

P = 90% rainfall number = 0.9 in

Rv = 0.05+0.009 (I) = 0.05+0.009(100) = 0.95

I = the percentage of impervious area draining to site = 100%

A = the Area Draining to Practice = 3,000 ft²

$$WQv = \frac{(0.90)(0.95)3,000}{12} \quad WQv = 213.75 \text{ ft}^3$$

Step 2: Calculate storage volume using equation above: Vol = (WQv) (7.5 gals/ ft³)

Vol = WQv x 7.5 gals/ ft³ (1603 gal)

Therefore, to treat the water quality volume for the area draining to the practice, a 1,650-gallon cistern is required. This equation must be utilized for the contributing drainage area to each downspout for the adequate sizing of a rain barrel or cistern. The calculated WQv is applied towards the Runoff Reduction Volume

Required Elements

A minimum amount of information must be provided in the SWPPP to obtain runoff reduction credit if using this practice. On a site map and summary table:

- Identify the area of rooftop proposed for capture in a rain barrel or cistern collection system
- Provide calculations verifying the WQv sizing criteria from Table 1 are satisfied by the proposal
- Identify the material specifications or manufacturer/model for the selected rain barrel or cistern
- Provide a plan and profile view of the proposed rain barrel or cistern layout around the building

New York State Stormwater Management Design Manual

Chapter 5: Green Infrastructure Practices

Section 5.3 Green Infrastructure Techniques

- Identify installation techniques to ensure proper placement and to allow for runoff overflows
- Identify maintenance requirements and educational brochures for continued operation of the practices.
- Provide a water budget analysis.
- Identify how water will be used to ensure that the system will be available for subsequent runoff events.

Figure 5.57 Cisterns can be incorporated into the overall landscaping of the site.



Environmental/Landscaping

An effort should be made to meet property owners' preferences in providing attractive above-ground rain barrels and cisterns. The likelihood of continued use of these practices is increased if they are an attractive part of the exterior setting (Figure 5.58). Landscaping or fencing may be used to shade rain barrels and cisterns to reduce algae growth and to provide visual screening, if desired.

Maintenance

Privately owned practices shall have a maintenance plan and shall be protected by easement, deed restriction, ordinance, or other legal measures preventing its neglect, adverse alteration, and removal. Cisterns are considered to be a permanent feature of the design and should be labeled as such to prevent removal. Maintenance requirements for rain barrels and cisterns vary depending on the end use of the collected water. Depending on the design and use of the system, winterization maintenance may also be necessary. Generally, routine system inspections should be conducted to ensure the system is available for storage of subsequent rain events and the following components inspected and either repaired or replaced as needed:

- Inspect roof catchments to ensure that minimal amounts of particulate matter or other contaminants are entering the gutter and downspout.
- Inspect the gutters and downspouts to check for leaks or obstructions.
- Inspect diverts, cleanout plugs, screens, covers, and overflow pipes and repair or replace as needed.
- Inspect inflow and outflow pipes as well as any accessories, such as connectors to adjacent storage containers or a water pump.

New York State Stormwater Management Design Manual

Chapter 5: Green Infrastructure Practices

Section 5.3 Green Infrastructure Techniques

References/Further Resources

Kessner, K., 2000. How to Build a Rainwater Catchment Cistern. *The March Hare*, Summer 2000, Issue 25, <http://www.dancingrabbit.org/building/cistern.html>

Low Impact Development Center, Inc. (LID). Accessed 2009. http://www.lid-stormwater.net/raincist_specs.htm

Maryland Environmental Design Program (MEDP). Accessed 2009. <http://www.dnr.state.md.us/ed/rainbarrel.html>

Metropolitan Council, 2001. Minnesota Urban Small Sites Best Management Practices (BMP) Manual. http://www.metrocouncil.org/environment/watershed/BMP/CH3_STInfilOnLot.pdf

Stensrod, O. and Gosback, J. September 1978. Translated May 1989, Johansen, J. and Seifert R.. *Water Cistern Construction for Small Houses*. Alaska Building Research Series, HCM-01557.

Texas Water Development Board (TWDB). 2005. *The Texas Manual on Rainwater Harvesting 3rd Edition*. http://www.twdb.state.tx.us/publications/reports/RainwaterHarvestingManual_3rdedition.pdf

The Urban Garden Center (UGC) <http://www.urbangardencenter.com/products/rainbarrel/index.html>

United States Environmental Protection Agency (USEPA). 2005. *National Management Measures to Control Nonpoint Source Pollution from Urban Areas*, EPA Document - EPA-841-B-05-004.

5.3.11 Porous Pavement

Description: Permeable paving is a broadly defined group of pervious types of pavements used for roads, parking, sidewalks, and plaza surfaces. Permeable paving provides an alternative to conventional asphalt and concrete surfaces and are designed to convey rainfall through the surface into an underlying reservoir where it can infiltrate, thereby reducing stormwater runoff from a site. In addition, permeable paving reduces impacts of impervious cover by augmenting the recharge of groundwater through infiltration, and providing some pollutant uptake in the underlying soils. Due to the potential high risk of clogging the pavement voids and the underlying soils, permeable paving should be limited in its use and should require strict adherence to manufacturer's specifications for installation and maintenance.

Permeable paving has three main design components: surface, storage, and outflow. The surface types of paving can be broken into two basic design variations: porous pavement and permeable pavers. *Porous pavement* is a permeable asphalt or concrete surface that allows stormwater to quickly infiltrate to an underlying reservoir. Porous pavement looks similar to conventional pavement, but is formulated with larger aggregate and less fine particles, which leaves void spaces for infiltration. *Permeable pavers* include reinforced turf, interlocking concrete modules, and brick pavers (Figure 5.59). Often, these designs do not have an underground stone reservoir, but can provide some infiltration and surface detention of stormwater to reduce runoff velocities.

Figure 5.58 Asphalt, Permeable Pavers, Porous Concrete, Albany, NY



The storage component includes coarse aggregate laid beneath porous surfaces, designed to store stormwater prior to infiltration into soils as well as distributing mechanical loads. The aggregate is wrapped in a non-woven geotextile to prevent migration of soil into the storage bed and resultant clogging. The storage bed also has a choker course of smaller aggregate to separate the storage bed from the surface course. The storage bed can be designed to manage runoff from areas other than the porous surface above it, or can be designed with additional storage to meet the Channel Protection Volume.

The outflow results from runoff percolation directly into the underlying soil, which recharges groundwater and removes stormwater pollutants. Systems designed for runoff reduction must be designed according to the capacity of the underlying soil and required elements of infiltration systems. Runoff can also be drained

New York State Stormwater Management Design Manual

Chapter 5: Green Infrastructure Practices

Section 5.3 Green Infrastructure Techniques

out of the stone reservoir through an underdrain system connected to the storm drain system. A perforated pipe system can convey water from the storage bed to an outflow structure. The outflow structure can be designed to provide Channel Protection.

Recommended Application of Practice

Permeable paving provides the structural support of conventional pavement, while reducing stormwater runoff by draining directly into the underlying base and soils. It can be used to treat low traffic roads (i.e., a few houses or a small cul-de-sac), single-family residential driveways, overflow parking areas, sidewalks, plazas, tennis or basketball courts, and courtyard areas. Good opportunities can be found in larger parking lots, spillover parking areas, schools, municipal facilities, and urban hardscapes. Permeable paving is intended to capture, infiltrate and/or manage small frequent rainfall events (i.e. channel protection). The practice can be applied in both redevelopment and new development scenarios.

Benefits

Permeable paving can have many benefits when applied to redevelopment and infill projects in urban centers. The most notable benefits include:

- Groundwater recharge augmentation
- Runoff reduction to ease capacity constraints in storm drain networks
- Effective pollutant treatment for solids, metals, nutrients, and hydrocarbons (see pollutant removal performance, Table 5.14)
- Aesthetic improvement to otherwise hard urban surfaces (e.g., interlocking permeable pavers, lattice pavers, Figure 5.60)

Two long-term monitoring studies of porous pavement systems conducted in Rockville, MD, and Prince William, VA, indicated high removal efficiencies for sediments and nutrients (see Table 5.14). The Rockville study also reported high removals for zinc (99%), lead (98%), and chemical oxygen demand (82%) (Schueler, 1987). The University of New Hampshire Stormwater Center found typical performance efficiencies for TSS, total Zinc, and total phosphorus to exceed 95%, 97%, and 42% respectively. (UNCSC, 2009)

Figure 5.59 Walkway with permeable pavers -Scenic Hudson Park, Cold Spring, NY



(NYSDEC. 2009)

| Table 5.14 Estimated Pollutant Removal Performance of Porous Pavement (Porous Asphalt) (EPA, 1999) | |
|---|------------------|
| Pollutant Parameter | % Removal |
| Total Phosphorus | 65 |
| Total Nitrogen | 80 – 85 |
| Total Suspended Solids | 82 – 95 |

Feasibility/Limitations

Major limitations to this practice are suitability of the site grades, subsoils, drainage characteristics, and groundwater conditions. Proper site selection is an important criterion in reducing the failure rate of this practice. Areas with high amounts of sediment-laden runoff and high traffic volume are likely causes of system failure. High volume parking lots, particularly parking drive aisles, high dust areas, and areas with heavy equipment traffic, are not recommended for this practice. Ownership and maintenance responsibility should also be considered in determining the potential for success.

Soil: It is important to confirm that local soils are permeable and can support adequate infiltration, since past grading, filling, disturbance, and compaction can greatly alter the original infiltration qualities. Sandy and silty soils are critical to successful application of permeable pavements. The HSG should be A, B or C.

Cold Climate Considerations: Permeable paving practices can be used effectively in cold-climate areas, but should not be used where sand or other materials are applied for winter traction since they quickly clog the pavement. Care should be taken when applying salt to permeable pavement, since chlorides can easily migrate into the groundwater. Care should also be taken to select a surface material that can tolerate undulations from frost movements, or to protect pavements from frost damage (Ferguson, 2005).

Winter maintenance is usually less maintenance intensive than that required by standard pavement. By its very nature, a porous pavement system with subsurface aggregate bed has better snow and ice melting characteristics than standard pavement. Once snow and ice melt, they flow through the porous pavement rather than re-freezing. Therefore, ice and light snow accumulation are generally not as problematic. However, snow will accumulate during heavier storms. Abrasives such as sand or cinders shall not be applied on or adjacent to the porous pavement. Snow plowing is acceptable, provided it is done carefully (i.e. by setting the blade about one inch higher than usual) (PA Design Manual).

New York State Stormwater Management Design Manual

Chapter 5: Green Infrastructure Practices

Section 5.3 Green Infrastructure Techniques

For design variation in cold climate frost depth consult UNHSC design specification (65% frost depth from the top of pavement to the native ground). (UNHSC, 2009)

Land Use: Like any stormwater infiltration practice, there is a possibility of groundwater contamination. Therefore, permeable paving infiltration systems shall not be used to treat stormwater hotspots, areas where land uses or activities have the potential to generate highly contaminated runoff. These areas may include, but are not limited to: commercial nurseries, auto recycling and repair facilities, fleet washing facilities, fueling stations, high-use commercial parking lots, and marinas. Additionally, certain types of permeable pavers, such as block, grid pavers, and gravel, are not ideal for areas that require handicap accessibility.

Siting: Permeable pavements shall not be used in areas where there are risks for foundation damage, basement flooding, interference with subsurface sewage disposal systems, or detrimental impacts to other underground structures.

Setbacks: The bottom of the storage reservoir shall be located at least 3 feet above the seasonally high groundwater table. Permeable pavement systems shall be separated by at least 100 horizontal feet away from drinking water wells and 25 feet down gradient from structures and septic systems.

Hotspot Runoff: Permeable pavements shall not be used to treat hotspots that generate higher concentrations of hydrocarbons, trace metals, or toxicants than are found in typical stormwater runoff and may contaminate groundwater.

Sizing and Design Criteria

These standards are intended to address the stormwater management aspect of porous pavement applications. They do not cover the structural integrity or traffic load design requirements. For such design detail please consult the references listed at the end of this section. The following lists the required elements of the design for runoff reduction, treatment, flood control, and maintenance.

Required Elements

SITE EVALUATION

- The area proposed for a porous pavement system must be fully evaluated, addressing all the factors including but not limited to infiltration, geotechnical, hotspot conditions, topography, and setbacks.

DRAINAGE

New York State Stormwater Management Design Manual

Chapter 5: Green Infrastructure Practices

Section 5.3 Green Infrastructure Techniques

- Runoff shall flow through and exit permeable pavements in a safe and non-erosive manner.
- Permeable pavements should be designed off-line whenever possible. Runoff from adjacent areas should be diverted to a stable conveyance system. If bypassing these areas is impractical, then runoff should sheetflow onto permeable pavements.
- The contributing drainage area should be limited to small adjacent impervious areas (i.e. non-traffic side walk and rooftops)
- When designing porous pavement systems for treatment of adjacent areas, the subbase storage must be designed with extra capacity by adding to the filter course. Adjacent impervious surfaces can also be graded so that the runoff from the impervious area sheet flows over the porous pavement or may be connected to the underlying storage bed. Pretreatment of impervious areas connected directly to the bed is required to prevent particulate materials clogging the subbase of the porous pavement system.
- Systems shall be designed to ensure that the water surface elevations for the 10-year, 24-hour design storm do not rise into the pavement to prevent freeze/thaw damage. Depending on the intended use of the system, a perforated pipe system (set at an elevation above the design storm that is intended for infiltration) can convey water from the storage bed to an outflow structure. The storage bed and outflow structure can be designed to control the Channel Protection and/or Flood Control requirement. Inlets can be used to provide positive overflow for impervious areas that are connected to the underlying storage bed, if additional rate control is not necessary.
- As a back-up measure in case of clogging, permeable paving practices can be designed with a perimeter trench to provide some overflow treatment should the surface clog. Pavement systems should include an alternate mode, such as a trench for runoff to enter the subbase reservoir. In curbless designs, this could consist of a 2-foot wide stone edge drain. Raised inlets may be required in curbed applications (from MD Manual).

TREATMENT

- Applications that are intended for infiltration shall be designed as infiltration practices using the design methods for infiltration trenches outlined in Chapter 6 of this Manual.
- Applications on poor soil, karst geology, or brown fields that require a liner will not provide the full runoff reduction value. However, this type of practice may be designed as a filtering system, t applied as a storage detention system for channel protection.

SOILS

- The underlying parent soils should have a minimum infiltration rate of 0.5 inches per hour. Soil testing is required as set forth in Appendix D of this Design Manual. To maintain effective pollutant removal in the underlying soils, organic matter content in the subsoils is important.

SLOPES

- Runoff should sheetflow across permeable pavement. Slopes across the surface and bottom of the stone reservoir should not exceed 5 percent to prevent ponding of water on the surface and within

New York State Stormwater Management Design Manual

Chapter 5: Green Infrastructure Practices

Section 5.3 Green Infrastructure Techniques

the subbase. Ideally it should be completely flat so that the infiltrated runoff will be able to infiltrate through the entire surface. A terraced system may be used on slopes. Perforated pipes may be used to distribute runoff through the reservoir evenly.

STRUCTURE

- All permeable pavement shall be capable of bearing the anticipated vehicle and traffic loads. Pavement systems conforming to the specifications found in this manual should be structurally stable for typical (e.g. light duty) applications. (MD Design Manual)
- Subbase aggregates shall be clean and free of fines. All aggregates within infiltration storage beds shall meet the following criteria:
 - Maximum wash loss of 0.5%
 - Minimum Durability Index of 35
 - Maximum abrasion of 10% for 100 revolutions and maximum of 50% for 500 revolutions
- Depth of the stone base can be adjusted depending on the management objectives, total drainage area, traffic load, and in-situ soil characteristics.

Construction Guidelines

- Installation procedures are vital to the success of pervious pavement projects, particularly pervious asphalt and concrete pavement mixes. The subgrade cannot be overly compacted with the inclusion of fine particulates or the void ratio critical to providing storage for large storm events will be lost. Weather conditions at the time of installation can affect the final product. Extremely high or low temperatures should be avoided during construction of pervious asphalt and concrete pavements.
- Areas for porous pavement systems shall be clearly marked before any site work begins to avoid soil disturbance and compaction during construction.
- Pervious pavement and other infiltration practices should be installed toward the end of the construction period. Upstream construction shall be completed and stabilized before connection to porous pavement system. A dense and vigorous vegetative cover shall be established over any contributing pervious drainage areas before runoff can be accepted into the facility.
- Subsurface area should be excavated to proposed depth. Existing subgrade shall NOT be compacted or subject to excessive construction equipment prior to placement of geotextile and stone bed. Where erosion of subgrade has caused accumulation of fine materials and/or surface ponding, this material shall be removed with light equipment and the underlying soils scarified to a minimum depth of 6 inches with a York rake or equivalent and light tractor.
- The bottom of the infiltration bed shall be at a level grade.
- Place geotextile and recharge bed aggregate immediately after approval of subgrade preparation to prevent accumulation of debris or sediment. Prevent runoff and sediment from entering the storage bed during the placement of the geotextile and aggregate bed.

New York State Stormwater Management Design Manual

Chapter 5: Green Infrastructure Practices

Section 5.3 Green Infrastructure Techniques

- Place geotextile in accordance with manufacturer's standards and recommendations. Adjacent strips of filter fabric shall overlap a minimum of 16 inches. Fabric shall be secured at least 4 feet outside of bed. This edge strip should remain in place until all bare soils contiguous to beds are stabilized and vegetated.
- As the site is fully stabilized, excess geotextile can be cut back to the edge of the bed.

Install aggregate course in lifts of 6-8 inches. Keep equipment movement over storage bed subgrades to a minimum. Install aggregate to grades indicated on the drawings. The materials of construction should be in accordance with specifications provided in Table 5.15. The engineer is responsible for developing detailed specifications and Quality Assurance/Quality Control measures for individual design projects.

Sizing

The basic equation for sizing the required porous surface area is as follows:

$$A_p = V_w / (n \times d_t)$$

where:

A_p = the required porous pavement surface area [square feet]

V_w = the design volume [cubic feet]

n = porosity of gravel bed/reservoir (assume 0.4)

d_t = depth of gravel bed/reservoir (maximum of four feet, and separated by at least three feet from seasonally high groundwater) [feet]

Design volume V_w may include WQ_v and CP_v from contributing area. An example calculation for porous pavement is provided in Table 5.16.

New York State Stormwater Management Design Manual

Chapter 5: Green Infrastructure Practices

Section 5.3 Green Infrastructure Techniques

Table 5.15 Material Specifications for Porous Pavement

| Material | Specification | | | Notes |
|--------------------------|---|---|---|---|
| | Porous Asphalt | Porous Concrete | Permeable Paver | |
| Pavement | 3"-7" Bituminous mix ½" Nominal Maximum Aggregate Size ≥18% Air Voids (50 gyrations) Draindown ≤0.3% | 4"-8" Portland Cement Type I or II (ASTM C 150), No. 8 (ASTM 33), Agg.:Cement Ratio 4:1 to 4.5:1 Water/Cement Ratio 0.28-0.35 | Varied shapes and sizes, 8%-10% surface opening, manufacturer specification, flow rate 5 in/hr or no less than 10% void | |
| Choker course | 4"-8" depth AASHTO No. 57 | None | 2" AASHTO No. 8 stone over 4" of No. 57 | Should be double-washed and clean and free of all fines |
| Filter Layer | 8"-12" No. 2 stone | No. 2 stone | No. 2 stone | Depth based on structural, storage, and hydraulic requirements. Double-washed, clean, free of fines |
| Drainage Layer | The underlying native soils should be separated from the filter layer by a 3 inch layer pea gravel over a reservoir course with at min. a 4 inch layer of choker stone (AASHTO No. 3 or 5). For design variation of thickness, storage, underdrain measure, and cold climate frost depth consult UNHSC design specification for reservoir course (UNHSC, 2009) | | | Sand should be placed between stone reservoir and choker stone, on top of underlying native soils. |
| Underdrain | Where system as a whole needs to meet storage/release criteria and overflow piping to minimize chance of clogging. 4"-6" perforated PVC (AASHTO M 252) pipe, with 3/8-inch perforations at 6 inches on center, solid connectors; each pipe at minimum 0.5% slope, 20 feet apart. Extend cleanout pipes to the surface with vented caps at Ts & Ys. | | | |
| Filter Fabric (optional) | Needled, non-woven, polypropylene geotextile with grab tensile strength greater or equal to 120 lbs (ASTM D4632), Mullen Burst strength greater or equal to 225 lbs/sq in (ASTM D3786), Flow rate greater than 125 gpm/sf (ASTM D4491) and Apparent Opening Size US # 70 or # 80 sieve (ASTM D4751). Geotextile AOS selection is based on the percent passing the No. 200 sieve in "A" Soil subgrade, using FHWA or AASHTO selection criteria | | | |
| Impermeable Liner | Minimum thirty mil PVC geomembrane liner covered by 8 to 12 oz/yd ² non-woven geotextile. Required only for Karst region and brown field applications. | | | |
| Observation Well | Perforated 4-6 inch vertical PVC pipe (AASHTO M 252), with lockable cap installed flush with the surface with surface cap. | | | |

New York State Stormwater Management Design Manual

Chapter 5: Green Infrastructure Practices

Section 5.3 Green Infrastructure Techniques

Table 5.16 Porous Pavement Simple Sizing Example

A porous pavement area is being designed to treat a 20,000 square foot drainage area. Based on the water quality volume required to treat this area, an assumed gravel bed/reservoir porosity of 0.4, and a gravel bed/reservoir depth of one foot, the following calculations were completed to determine the required porous pavement surface area.

Step 1: Calculate the WQv

$$WQv = \frac{(P)(Rv)A}{12}$$

where:

P = 90% rainfall number = 0.9 in

Rv = 0.05+0.009 (I) = 0.05+0.009(100) = 0.95

I = percentage impervious area draining to site = 100%

A = Area Draining to Practice (i.e., treatment area) = 20,000 ft²

$$WQv = \frac{(0.90)(0.95)20,000}{12} \quad WQv = 1,425 \text{ ft}^3$$

Step 2: Calculate the available storage volume in the storage reservoir:

$$\text{Storage Volume} = A_p * n * d_t$$

where:

n = assumed porosity = 0.4

d_t = gravel bed/reservoir depth = 1 ft

Storage Volume = 20,000 sf * 0.4 * 1 ft

Storage Volume = 8,000 cf

Which is much higher than required for the 90th percentile storm event (1425 cf).

The storage reservoir could hold up to 5” of direct rainfall onto the pavement

Step 3: Determine storage available for treatment of additional impervious area (limited to rooftops, sidewalks and other non-vehicular surfaces), CPv or higher storms:

$$\text{Available Storage} = \text{Reservoir Storage Volume} - WQv$$

$$\text{Available Storage} = 8000 \text{ cf} - 1425 \text{ cf} = 6575 \text{ cf}$$

$$\text{Additional area} = \text{Volume (cf)} / P(\text{inches}) / Rv * 12 \text{ in/ft}$$

$$\text{Additional Impervious Area} = 6575 \text{ cf} / 0.9 \text{ inches} / 0.95 * 12 \text{ in/ft} = 92,280 \text{ sf}$$

New York State Stormwater Management Design Manual

Chapter 5: Green Infrastructure Practices

Section 5.3 Green Infrastructure Techniques

Step 4: Determine height WQ_v would reach within the storage chamber:

$d = 1425 \text{ cf}/20,000 \text{ sf}/0.4 = 2 \text{ inches}$ (10 inches is available for storage of higher storms.

In order to receive runoff reduction credit, the overflow device must be set at least 2 inches above the bottom.

Therefore, the 20,000 square feet of porous pavement with a 1 foot deep storage reservoir can provide treatment and storage for about 4.5" rainfall onto its' surface or runoff from immediate adjacent areas.

New York State Stormwater Management Design Manual

Chapter 5: Green Infrastructure Practices

Section 5.3 Green Infrastructure Techniques

Permeable paver (e.g., interlocking block, concrete grid pavers, etc.) areas that do not have a storage reservoir are most effective when designed to accommodate small rainfall depths (e.g., less than 1 inch) that fall directly on the paver areas. They are less effective and more prone to clogging when used to also receive runoff from other areas. Unless underlying soils are extremely permeable, larger storms will either sheet flow off the site, or if not graded properly, will pond on the site. To address these concerns, the following restrictions are placed on the use of permeable pavers installed without an underlying storage reservoir:

- The area of application is not subject to traffic (allowed for patios, walkways, small driveways)
- The area of application must overlay highly permeable soils (A or B).
- No additional area drains onto the paver area.

Provided that these criteria are met, the application area shall be treated as pervious. However no storage credit is applied. Pavers with a gravel reservoir are treated the same as porous concrete and asphalt (size the reservoir to store the WQv).

Environmental/Landscaping Considerations

Stringent sediment controls are required during the construction stage, and all adjacent land areas should be stabilized prior to installing permeable paving practices. Where feasible, a grass filter strip is recommended to pre-treat adjacent land areas that drain to porous pavement areas.

Maintenance

- Permeable pavements are highly susceptible to clogging and subject to owner neglect. Individual owners need to be educated to ensure that proper maintenance and winter operation activities will allow the system to function properly.
- The type of permeable paving and the location of the site dictate the required maintenance level and failure rate. Concrete grid pavers and plastic modular blocks require less maintenance because they are not clogged by sediment as easily as porous asphalt and concrete. Areas that receive high volumes of sediment will require frequent maintenance activities, and areas that experience high volumes of vehicular traffic will clog more readily due to soil compaction. Typical maintenance activities for permeable paving are summarized below (Table 5.17).

New York State Stormwater Management Design Manual

Chapter 5: Green Infrastructure Practices

Section 5.3 Green Infrastructure Techniques

Table 5.17 Typical Maintenance Activities for Permeable Paving (WMI, 1997)

| Activity | Schedule |
|---|-----------------------------------|
| Ensure that paving area is clean of debris | Monthly |
| Ensure that paving dewaterers between storms | Monthly and after storms >0.5 in. |
| Ensure that the area is clean of sediments | Monthly |
| Mow upland and adjacent areas, and seed bare areas | As needed |
| Vacuum sweep frequently to keep surface free of sediments | Typically 3 to 4 times a year |
| Inspect the surface for deterioration or spalling | Annual |

When maintenance of permeable paving areas is required, the cause of the maintenance should be understood prior to commencing repairs so unnecessary difficulties and recurring costs can be avoided (Ferguson, 2005). Generally, routine vacuum sweeping and high-pressure washing (with proper disposal of removed material and washwater) can maintain infiltration rates when clogged or crusted material is removed. Signs can also be posted visibly within a permeable paving area to prevent such activities as resurfacing, the use of abrasives, and to restrict truck parking.

References/Further Resources

Ferguson, B. 2005. *Porous Pavements*. CRC Press.

Low Impact Development Center, Inc. (LID) <http://www.lid-stormwater.net/intro/sitemap.htm#permpavers>

Schueler, T. 1987. *Controlling Urban Runoff: A Practical manual for Planning and Designing Urban BMPs*. Metropolitan Washington Council of Governments. Washington, DC

University of New Hampshire Stormwater Center, UNCSC Design Specifications for Porous Asphalt Pavement and Infiltration Beds. Oct. 2009.

United States Environmental Protection Agency (EPA), "Storm Water Technology Fact Sheet, Porous Pavement." September 1999.

Watershed Management Institute (WMI). 1997. *Operation, Maintenance, and Management of Stormwater Management Systems*. Prepared for: US EPA Office of Water. Washington, DC.