

Madison Manufacturing Company, Inc.

172 South Andrews Ave. | PO Box 187
Hot Springs, NC 28743-0187 | USA
Phone: 828-622-7500 | 1-800-613-4766
Fax: 828-622-3309

Web: www.peerlessblowers.com
Email: salesteam@peerlessblowers.com

PLENUM^{classic}

Plenum Fan

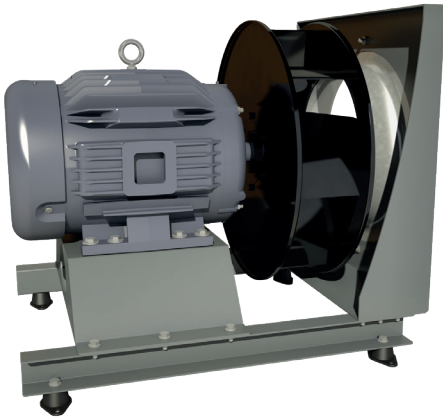

Standard Product Features:

The **PLENUM^{classic}** is a direct drive fan with a single inlet, high-efficiency radial diffuser fan wheel mounted on a NEMA Premium Efficiency motor. Motor speed can be controlled with a VFD. The radial fan wheel is made of powder coated steel with backward curved, welded blades. The aerodynamically coordinated galvanized steel inlet cone is equipped with a blind rivet nut for connecting a pressure tap. The fan frame is made from powder coated steel. The complete unit is statically and dynamically balanced.

Motors are NEMA Premium Efficiency | Motor enclosure: TEFC | Motor protection class: IP 54 | Motor insulation class: F | Direction of fan rotation: clockwise (suction side view)

MOTOR SHOWN FOR REFERENCE ONLY

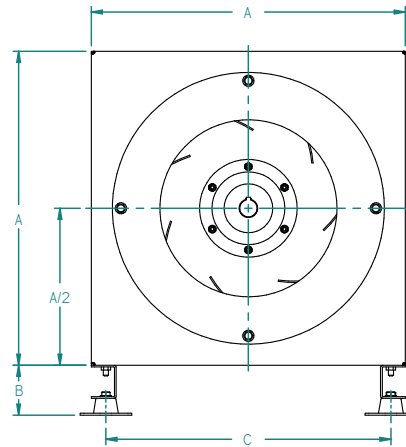
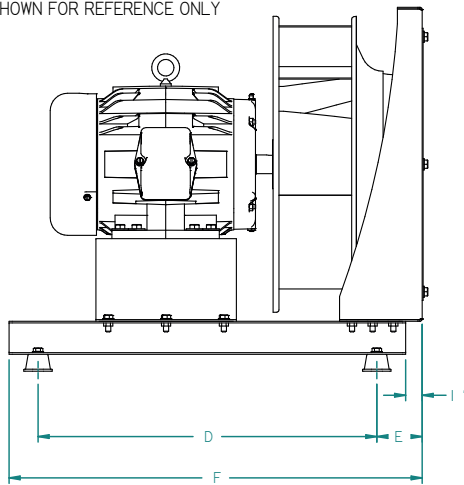

Model	Power (hp)	max. Speed (rpm)	Motor Frame Size	A (inch)	A/2 (inch)	B (inch)	C (inch)	D (inch)	E (inch)	F (inch)	Unit Weight* (lbs)
PLENUM^{classic} 350	7.3	3,990	215T	17	8 ½	3 ¼	15 ¼	20 ½	2 ¾	25	48
PLENUM^{classic} 400	9.0	3,520	215T	19	9 ½	3 ¼	17 ¼	20 ½	2 ¾	25	56
PLENUM^{classic} 450	11.2	3,100	254T	21	10 ½	3 ¼	19 ¼	22 ½	2 ¾	27	85
PLENUM^{classic} 500	13.9	2,780	256T	23	11 ½	3 ¼	21 ¼	24 ½	2 ¾	29	95
PLENUM^{classic} 560	17.3	2,450	284TS	29	14 ½	3 ¼	27 ¼	34 ½	2 ¾	29	125

*fan weight without motor

Performance Data

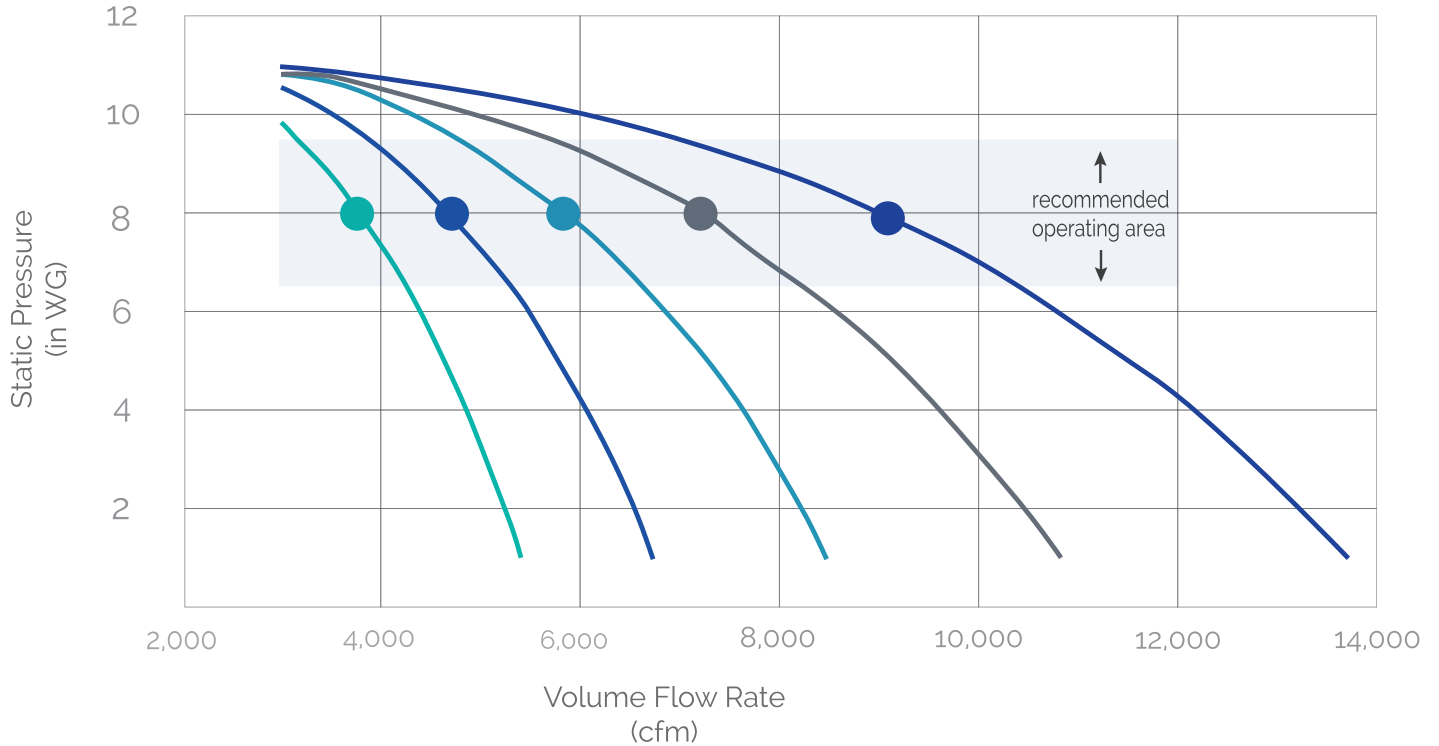

The characteristic curves shown are valid for measurements on a testing setup built in accordance with ISO 5801 (DIN 24163) and may vary depending on the mounting situation. In principle, it has to be taken into account that these characteristic values were recorded under laboratory conditions. The real data are to be evaluated in consideration of further marginal conditions.

Model	Best Efficiency Point	Volume Flow (cfm)	p_{sf} (in WG)	Lw6A [dB(A)]	System Efficiency Static (%)	P_e (hp)	n (rpm)
PLENUMclassic 355		3,740	8	98	59.0	7.9	3,990
PLENUMclassic 400		4,650	8	99	59.3	9.8	3,520
PLENUMclassic 450		5,800	8	100	60.0	12.1	3,100
PLENUMclassic 500		7,370	8	102	60.3	15.4	2,780
PLENUMclassic 560		8,930	8	103	60.6	18.6	2,450



Peerless Blowers | Madison Manufacturing Company, Inc.

172 South Andrews Ave. | PO Box 187
Hot Springs, NC 28743-0187 | USA
Phone: 828-622-7500 | 1-800-613-4766

Fax: 828-622-3309
Web: www.peerlessblowers.com
Email: salesteam@peerlessblowers.com