



willowlamp
CONDENSED

WELCOME

TO THE WORLD
OF WILLOWLAMP

SIMPLE IDEAS, BEAUTIFULLY EXECUTED

The willowlamp success story began with a single simple idea: the willowlamp notch system that allows curtains of ball-chain to flow elegantly from laser-cut steel frames. Today, our award-winning, cutting-edge designs bring life and light to large and small spaces all over the world.

Our original lighting designs are shaped by the principles of sacred geometry and built with world-class lighting technology, craftsmanship and superior materials to create timeless yet functional works of art.

When you invest in a willowlamp, it will be a true investment in style, creativity and individual expression.

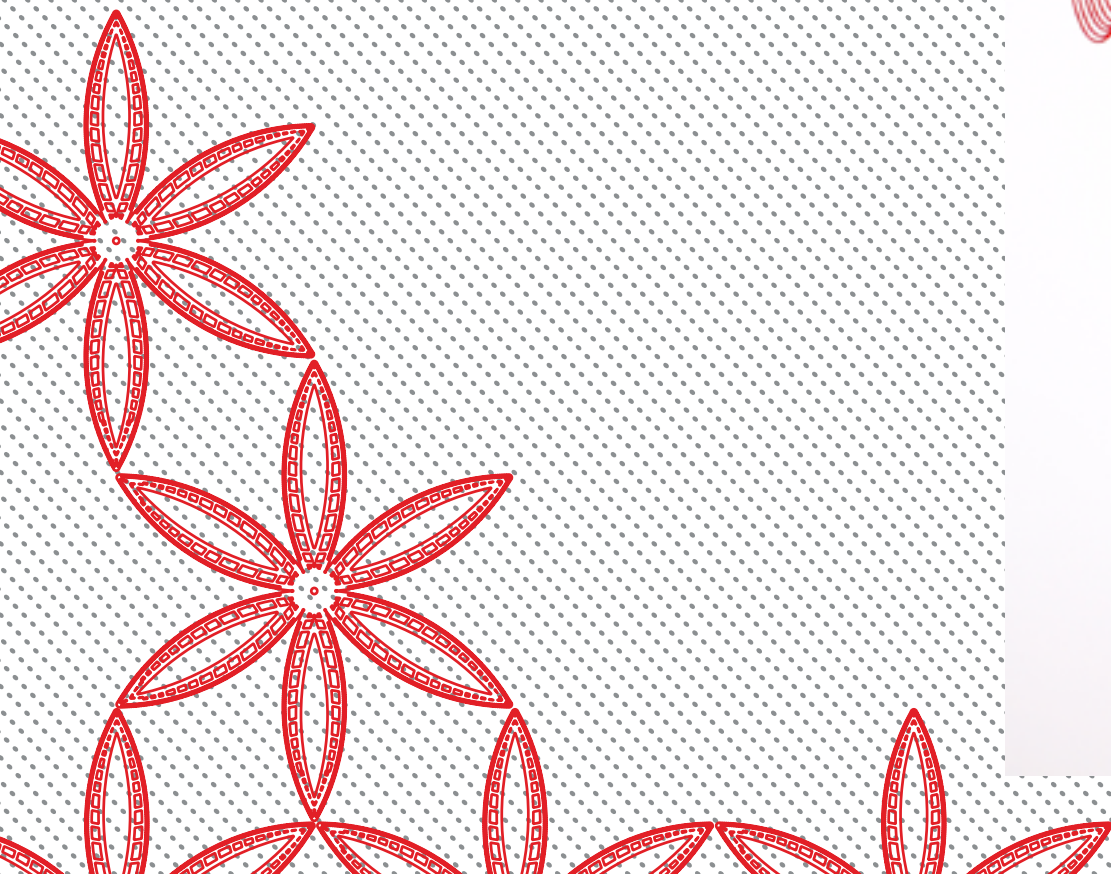



ADAM HOETS - FOUNDER AND CREATIVE DIRECTOR

Adam Hoets is the founder and creative director of willowlamp. He is inspired by nature's sculptural forms. His designs are imbued with the beauty he sees everywhere.

His obsessive understanding of each design results in beautiful products that combine aesthetics and technical detail with a consistent quality found in every willowlamp, from the most breath-taking chandelier to a table lamp that is perfectly subtle in its simplicity.

Adam graduated as an architect from the University of Cape Town in 2000 and later specialised in designing sustainable buildings that integrate harmoniously into their surroundings with sculptural forms. Adam lives and works on the slopes of Table Mountain in Cape Town.

willowlamp is the next chapter in his journey as an artist and designer.

The Southern Flame for Southern Guild 2018



CUSTOM DESIGN

CUSTOM-DESIGN YOUR OWN WILLOWLAMP

Unleash your creativity and let your imagination fly to create the perfect willowlamp that represents your individual style.

Our custom willowlamp design service is ideal for creating a beautiful and striking impact on any room. We have created bespoke installations for hotels and private homes all over the world. Custom-made willowlamps can be large installations, one-off creations or limited editions. willowlamp's patented notch system is so simple yet so versatile, giving us the flexibility to give form to your individual ideas. We are able to design a light that brings life to any space, regardless of height, volume or shape.

When you design your own willowlamp it will be a true one-off that does not exist anywhere else in the world. When you invest in a willowlamp, it will be a true investment in style, creativity and individual expression.

Visit willowlamp.com for specifications, ordering processes, safety information and terms and conditions.



A massive 1000kg elliptical shaped Mandala for the Marriott Hotel, Charlotte, Virginia, 2020

EXAMPLES OF CUSTOM-DESIGN



A massive 400kg 2.8m diameter 6.5m long Flower of Life chandelier for the Mena-House Hotel in Egypt



A 16 tier version of our Enchanted Faraway Tree, with a colour gradient of different metallics



Custom Flower of Life 27m dia. in Chrome | Mena House Hotel | Giza, Egypt



Mandala Cluster | Crown Perth Hotel | Perth, Australia

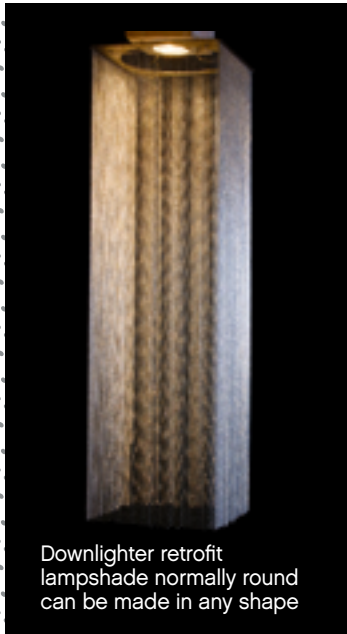

Downlighter retrofit lampshade normally round can be made in any shape



The Pod, normally long and slender has been modified in proportion into a wide 'basket-like' form

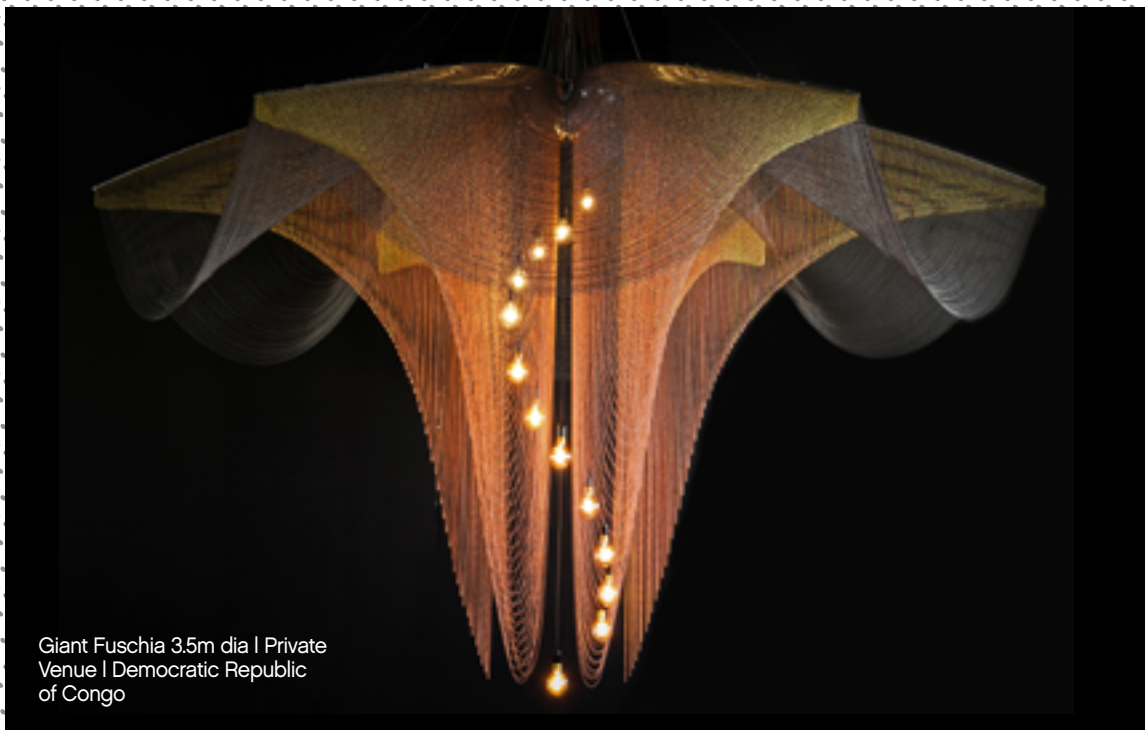

Giant Fuschia 3.5m dia | Private Venue | Democratic Republic of Congo

MODIFIED EXISTING WILLOWLAMP



Here we literally stacked our 'flower of life' design to create a single large multiple level chandelier.

ORIGINAL CUSTOM DESIGN



A massive extruded geometric Islamic star pattern in various metallic chain finishes.



An Enchanted Forest | Private residence | London



ART PIECES

CHANDELIERS



ART PIECES

CHANDELIERS

The nitrogen in our DNA, the calcium in our teeth, the iron in our blood, the carbon in our apple pies were made in the interiors of collapsing stars. We are made of starstuff. Carl Sagan,

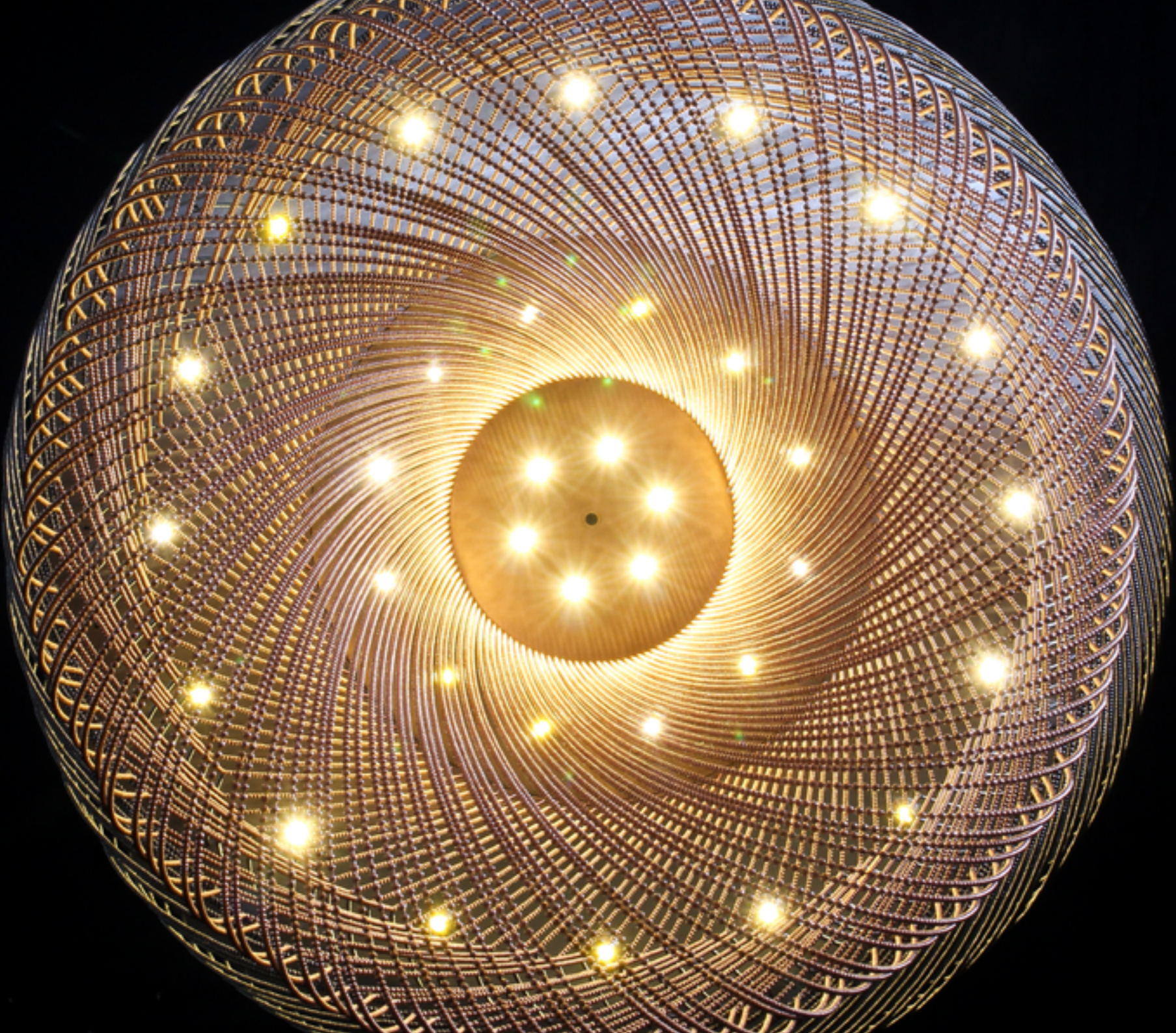

HELLO





HALO

DESCRIPTION
 A FUTURISTIC GHOSTLIKE SEMI TRANSPARENT FORM. THE SUCCESS OF THIS DESIGN RESULTS FROM AN INGENUOUS CLIP DEVICE WHICH HAS ENABLED US FOR THE FIRST TIME TO ATTACH THE BALL CHAIN TO ITSELF! THIS ALLOWS FOR DYNAMIC AND DISTORTED CURVES TO BE CREATED. THE IDEA IS INSPIRED BY ANTONI GAUDI WHO USED INVERTED CHAIN MODELS IN THE STRUCTURAL DESIGN FOR THE SAGRADA FAMILIA.



MODEL	SHADE SIZE	TOTAL HEIGHT
HALO - SUSPENDED - 1000	1000W X 1345H MM	1695MM
HALO - CEILING MOUNTED - 1000	1000W X 1070H MM	1090MM

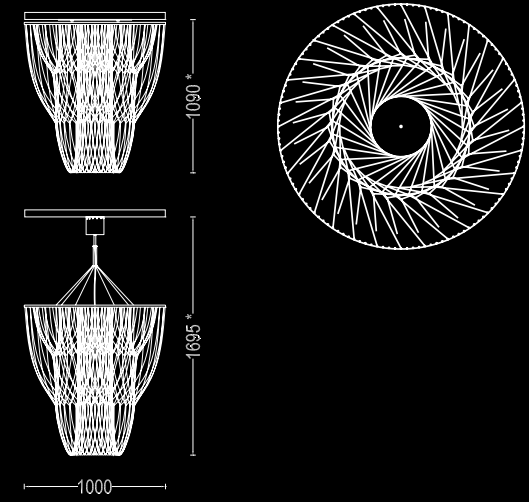

THE LINK



THE LINK

DESCRIPTION

A DRAMATIC, GEOMETRIC SCULPTURAL DESIGN RESEMBLING ABSTRACTED GIANT LINKS OF CHAIN. THE USE OF TWO CHAIN TONES ENHANCES THE THREE DIMENSIONALITY OF THE ARTWORK. THE DESIGN IS CUSTOMIZABLE IN THAT ADDITIONAL LINKS MAY BE ADDED TO CREATE AN EVEN LONGER CHAIN. ILLUMINATED BY AN ARRAY OF G4 UFO LED'S

MODEL	SHADE SIZE	TOTAL HEIGHT
THE LINK - SUSPENDED - 1000	700x700W X 1610H MM	1845MM

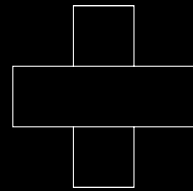

1-TIER

2-TIER

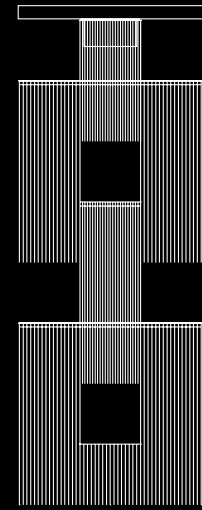

700

1845 *



GEOMETRIC STORM



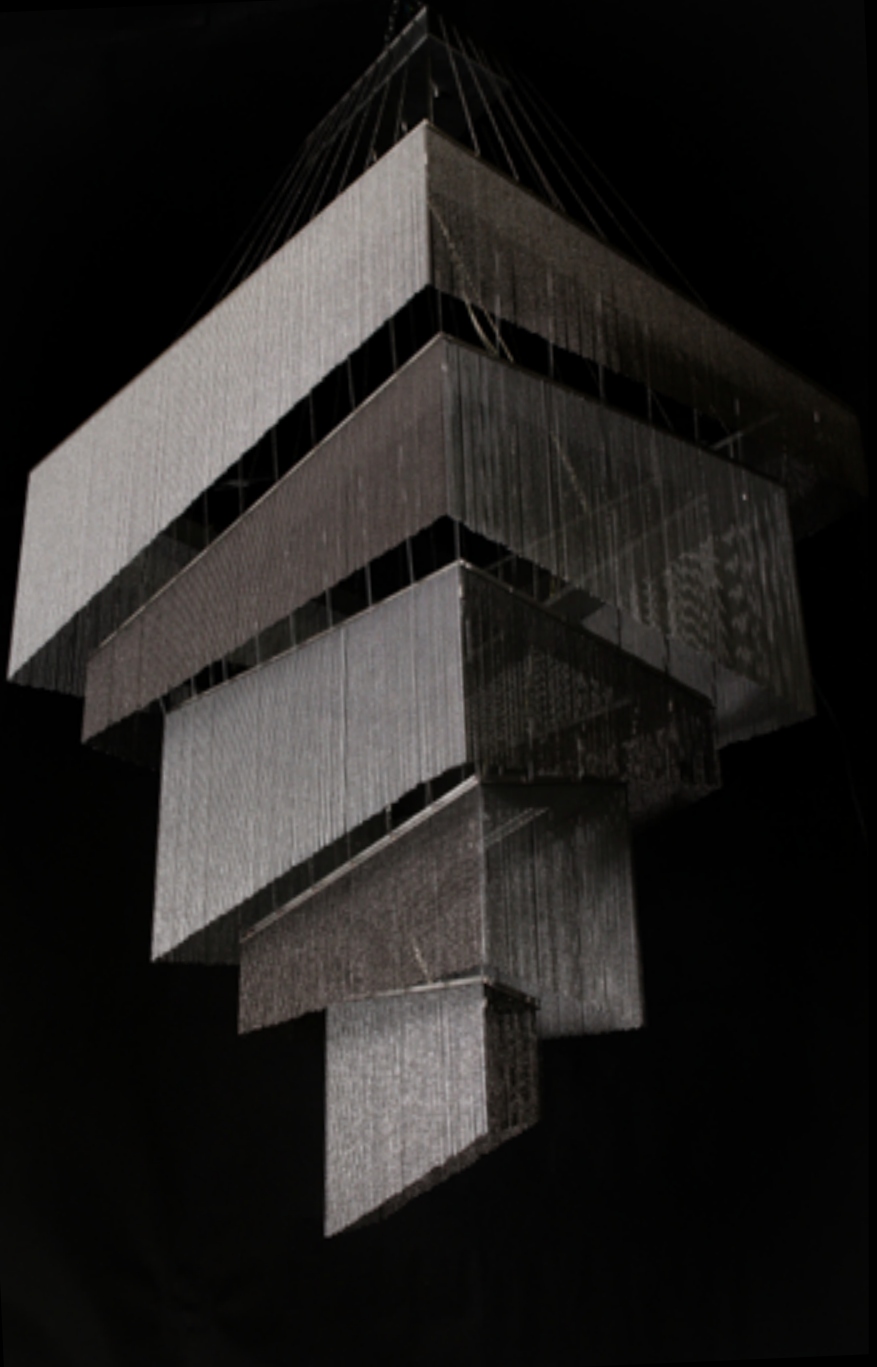

GEOMETRIC STORM

DESCRIPTION

THE GEOMETRIC STORM IS INSPIRED BY ABSTRACT ART MAINLY CUBISM AND LAYERED LANDSCAPES. IT EVOKES A HIGHLY GEOMETRICIZED LANDSCAPE FROM AN ALTERNATE ABSTRACT CUBIST REALITY. THIS VERSION IS A LIMITED EDITION OF 10 PIECES AND HAS A MIXTURE OF SMOKE AND SILVER CHAIN TO CREATE AN INTERPLAY OF SHADOW AND LIGHT. IT IS ILLUMINATED BY LED AND G4 HALOGEN/LED SYSTEMS

MODEL	SHADE SIZE	TOTAL HEIGHT
GEOMETRIC STORM - 1200X900	900X1200 X 1400H MM	2270MM

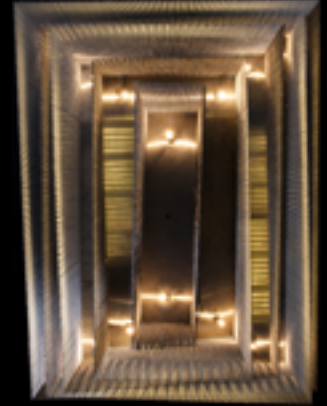
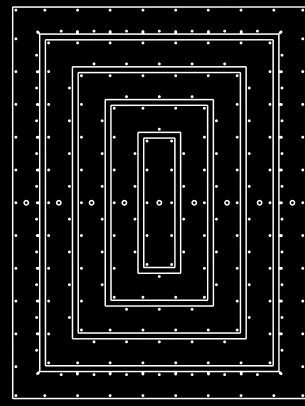
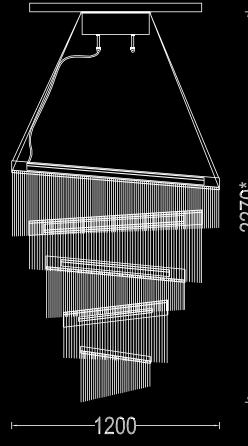

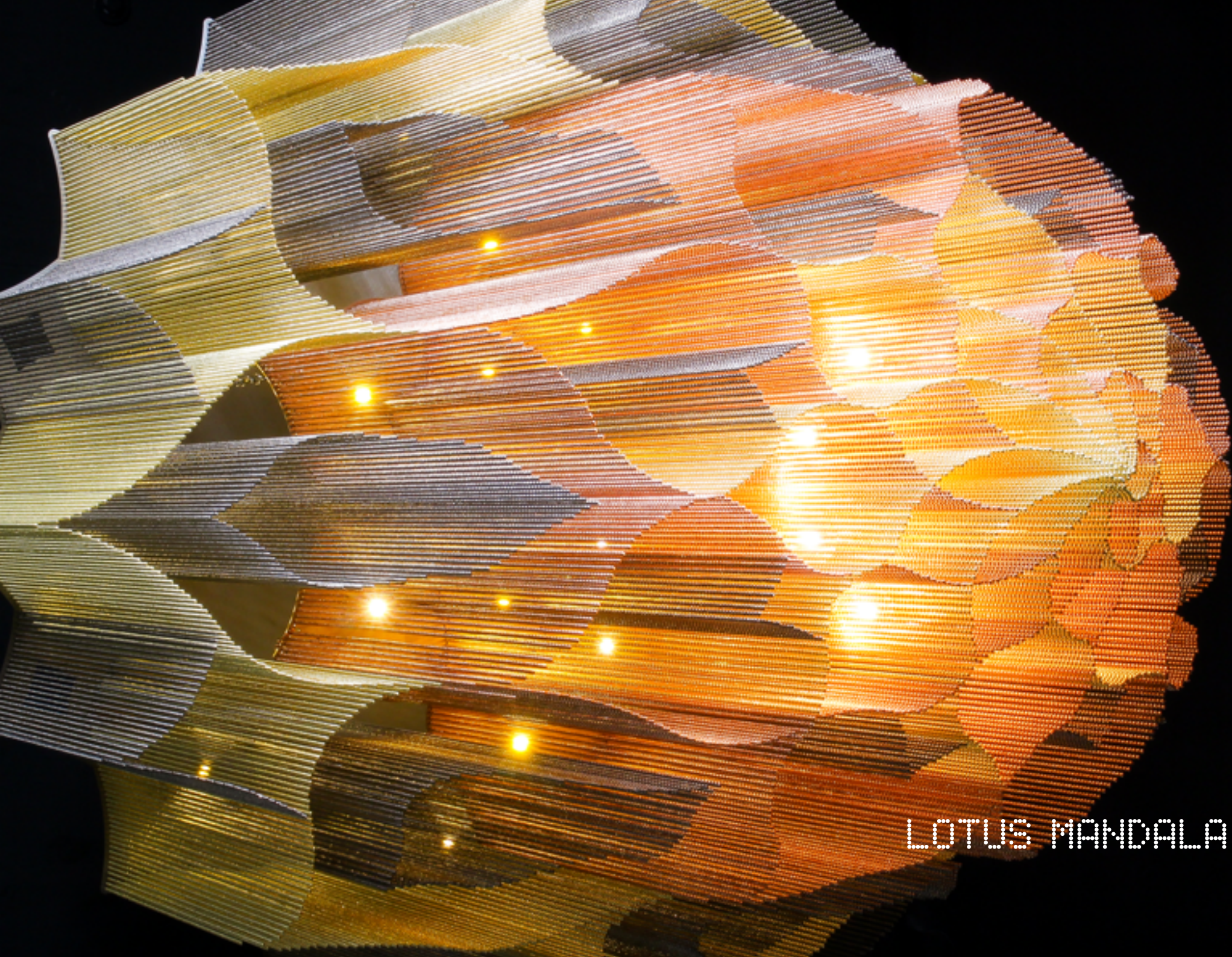

LOTUS MANDALA



LOTUS MANDALA

DESCRIPTION
 AN EXTREMELY BEAUTIFUL SACRED LOTUS FLOWER MANDALA. ILLUMINATED BY 40 SURFACE MOUNTED AND SUSPENDED LED LAMPS.
 OPTIONAL EXTRA: THE DESIGN FEATURES A MECHANISM THAT CAN CREATE A RIPPLING MOVEMENT IN THE CHAIN - ON SPECIAL REQUEST ONLY.

MODEL	SHADE SIZE	TOTAL HEIGHT
LOTUS MANADALA - SUSPENDED - 1000	1000W X 1085H MM	1590MM
LOTUS MANADALA - CEILING MOUNTED - 1000	1000W X 1080H MM	1100MM

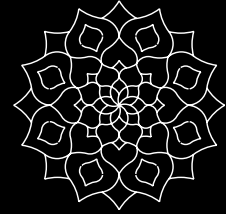
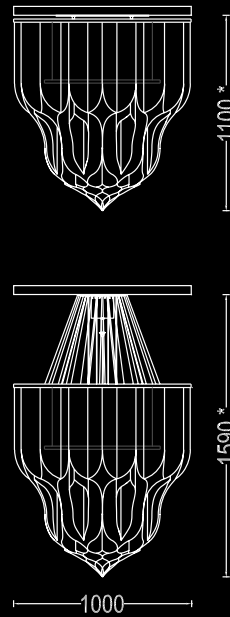



CRYSTAL MANDALA

CRYSTAL MANDALA

DESCRIPTION

A SLEEKER SIMPLIFIED CRYSTALLINE VERSION OF THE MANDALA NO.1. ILLUMINATED BY 42 SURFACE MOUNTED AND SUSPENDED LED LAMPS.
 OPTIONAL EXTRA: THE DESIGN FEATURES A MECHANISM THAT CAN CREATE A RIPPLING MOVEMENT IN THE CHAIN - ON SPECIAL REQUEST ONLY.

MODEL	SHADE SIZE	TOTAL HEIGHT
CRYSTAL MANDALA - SUSPENDED - 1000	1000W X 1225H MM	1725MM
CRYSTAL MANDALA - CEILING MOUNTED - 1000	1000W X 1220H MM	1240MM

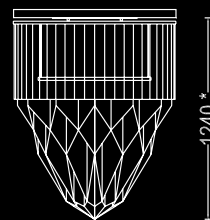

1240 *

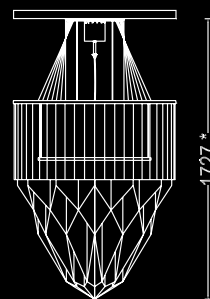
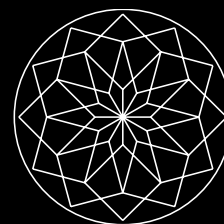

1727 *

1000



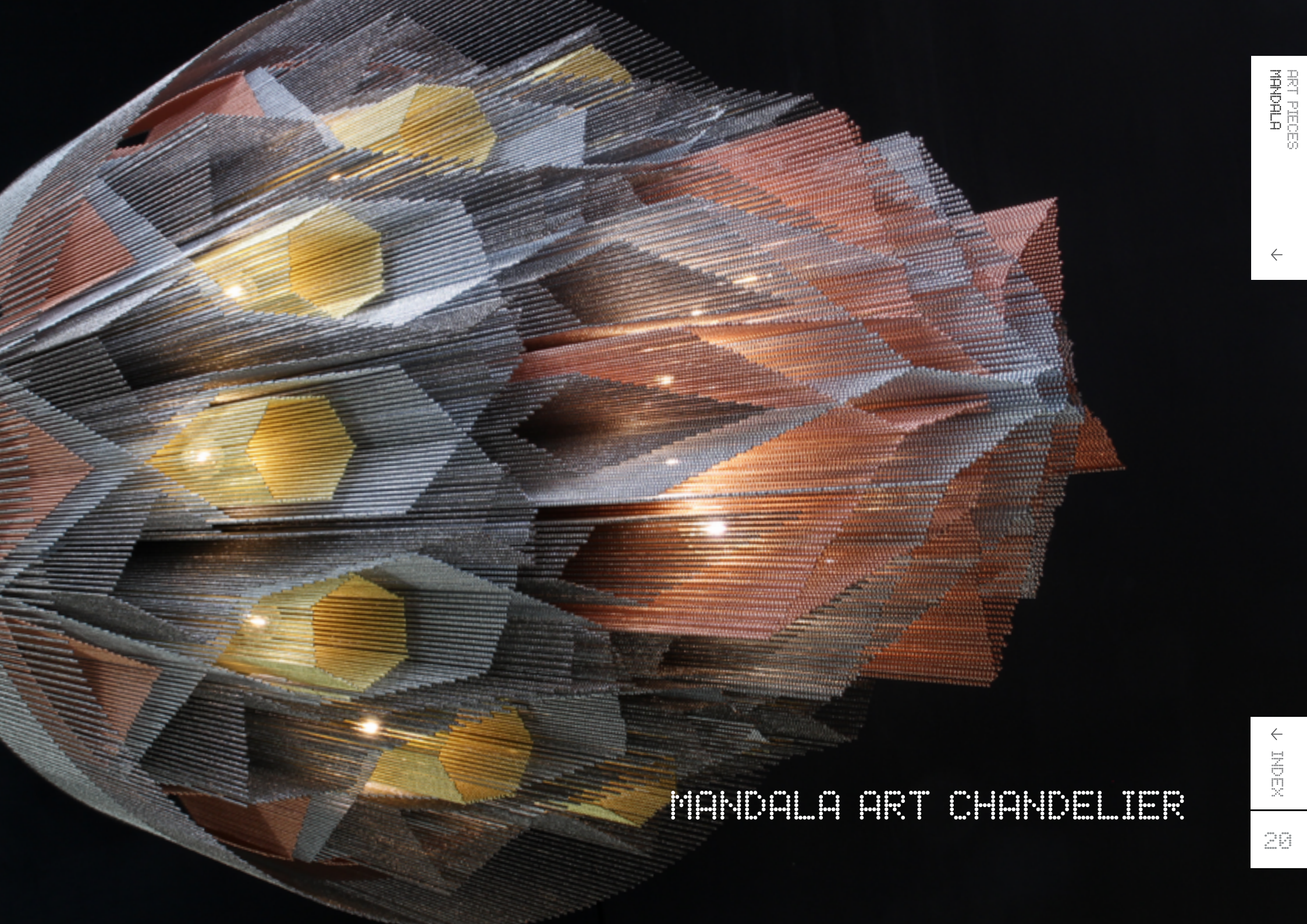

MANDALA ART CHANDELIER

MANDALA ART CHANDELIER

DESCRIPTION
A MASSIVE, INTENSE ILLUMINATED MANDALA SCULPTURE INSPIRED BY ISLAMIC PATTERNS WHICH HAVE BEEN TRANSLATED INTO THREE DIMENSIONS BY EXTRUDING THE COMPLEX INTERLOCKING GEOMETRY. MADE FROM LASER CUT STAINLESS STEEL FRAMES, CHROME PLATED OR LACQUERED SOLID BRASS COMPONENTS, BALLCHAIN IN SEVERAL OPTIONAL FINISHES. ILLUMINATED BY SUSPENDED G4 HALOGEN/LED LAMPS.

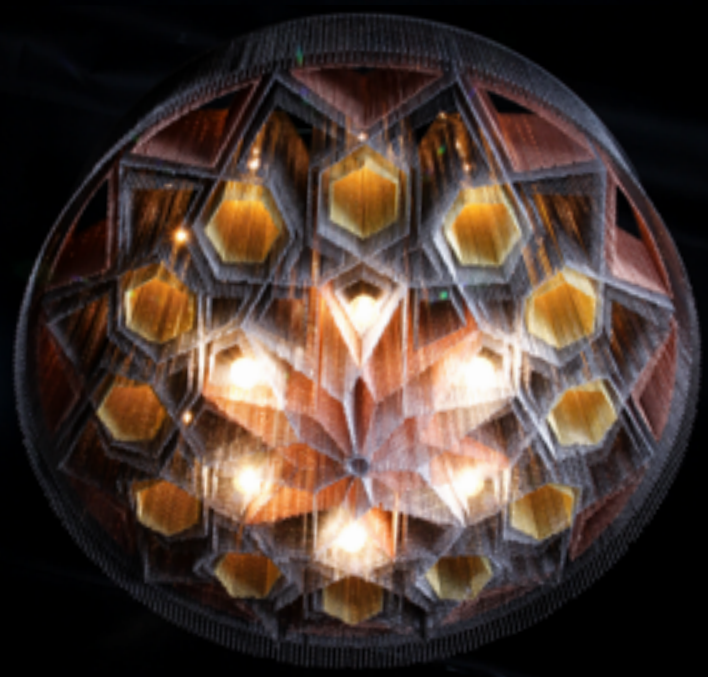

MODEL	SHADE SIZE	TOTAL HEIGHT
MANDALA NO.1 - 1000	1000W X 1920H MM	2200MM
MANDALA NO.2 - 1000MM DIA	1000W X 500H MM	1400MM

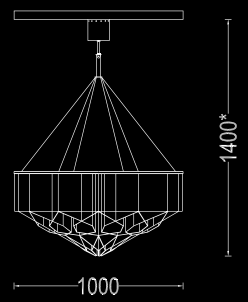
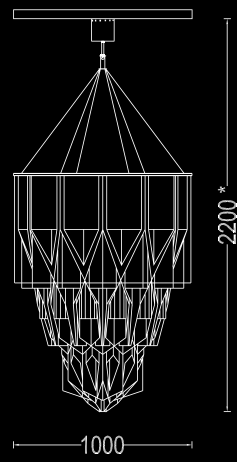
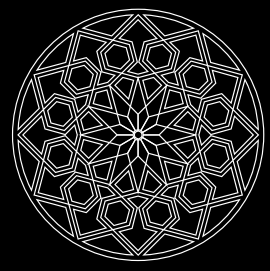



SPIRAL NEBULA





SPIRAL NEBULA

DESCRIPTION

A COLLECTION OF ILLUMINATED SCULPTURAL ART FORMS INSPIRED BY THE SPIRAL FORMS FOUND IN NATURE. THESE FORMS ARE MANIFEST IN THE MICRO AND MACRO COSMOS... FROM SEASHELLS TO SPIRAL NEBULA GALAXIES. THE DESIGNS ARE CHARACTERISED BY WINDING METAL SPIRALS THAT ARE WEIGHTED DOWN BY THE CHAIN AND ILLUMINATED BY A COMBINATION OF G4 HALOGEN AND LED LIGHTING SYSTEMS. THEY CAN BE TAILORED ON REQUEST AND CUSTOMISED TO THE SPECIFIC NEEDS OF THEIR ENVIRONMENT.

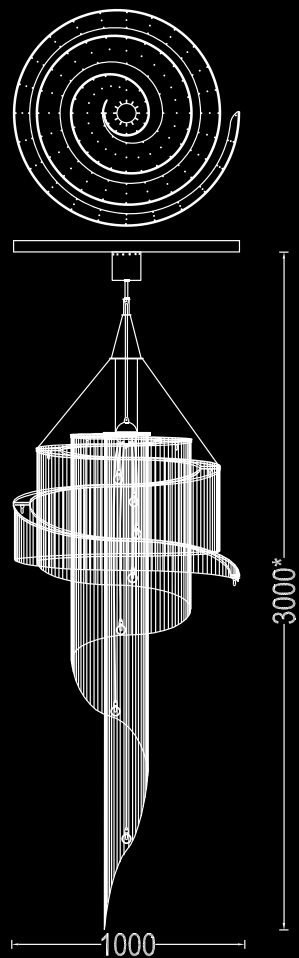

MODEL

SHADE SIZE

TOTAL HEIGHT

SPIRAL NEBULA - 1000

1000W X 2200H MM

3000MM



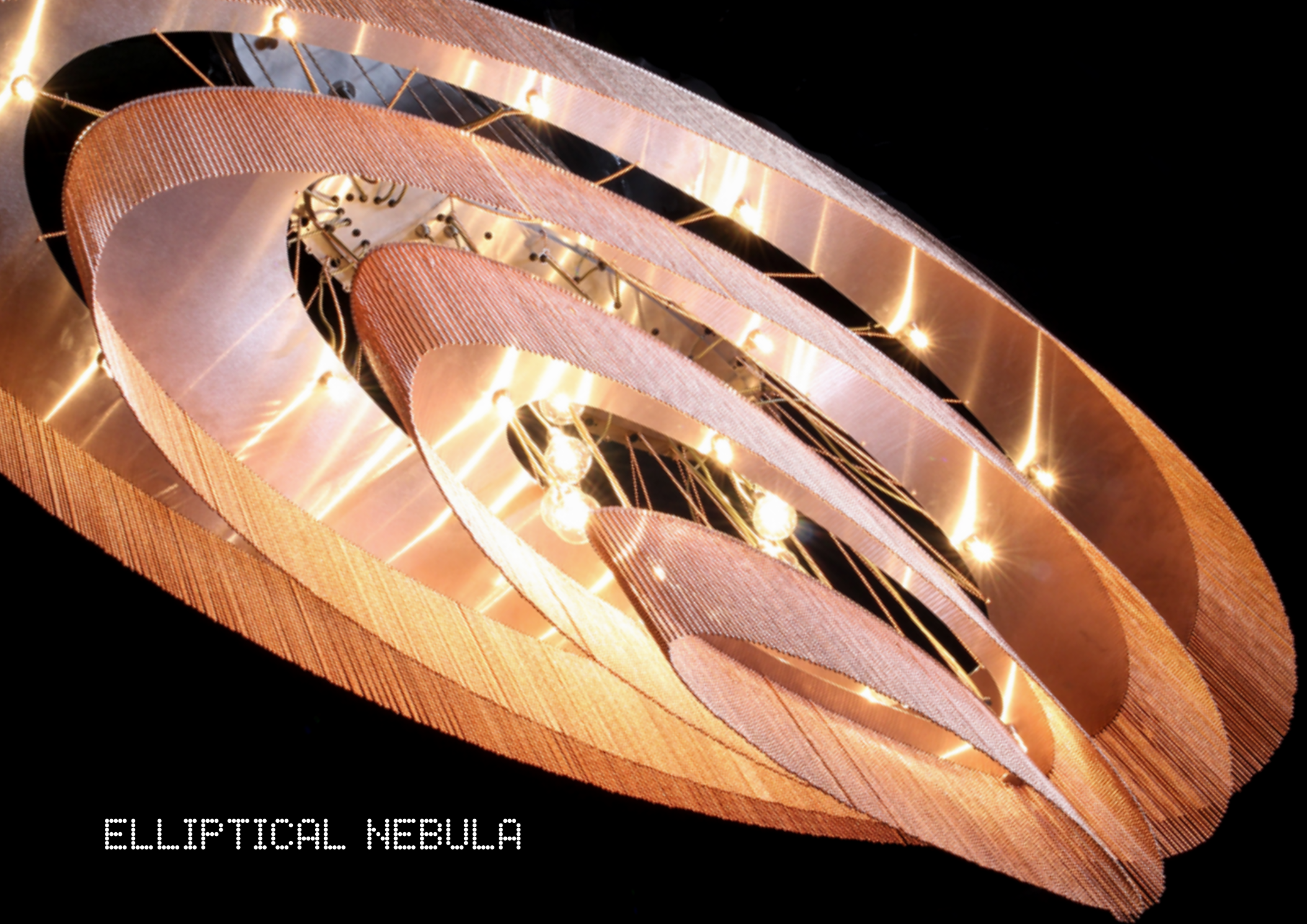

ELLIPTICAL NEBULA





ELLIPTICAL NEBULA



DESCRIPTION

A COLLECTION OF ILLUMINATED SCULPTURAL ART FORMS INSPIRED BY SPIRAL PREVALENT THROUGHOUT NATURE. THESE FORMS ARE MANIFEST IN THE MICRO AND MACRO COSMOS... FROM SEASHELLS TO SPIRAL NEBULA GALAXIES.

THE DESIGNS ARE CHARACTERIZED BY WINDING METAL SPIRALS THAT COLLAPSE UNDER THE WEIGHT OF THE CHAIN AND ILLUMINATED BY A COMBINATION OF G4 HALOGEN AND/OR LED LIGHTING SYSTEMS.

THEY CAN ON REQUEST, BE TAILORED AND CUSTOMISED TO THE SPECIFIC NEEDS OF THEIR ENVIRONMENT.

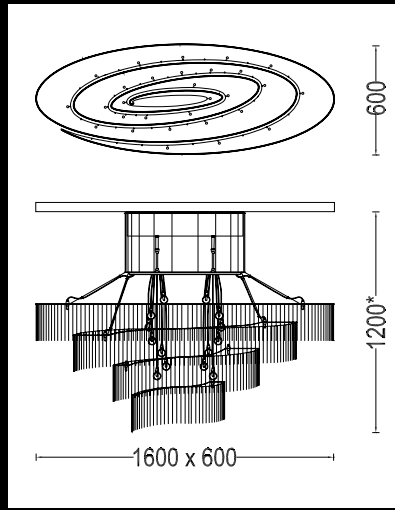

MODEL	SHADE SIZE	TOTAL HEIGHT
ELLIPTICAL NEBULA - 1600X600	1600X600W X 700H MM	1200MM





LEON



DROPLET

DESCRIPTION
 THIS HIGHLY ECLECTIC DESIGN IS INSPIRED BY A DRIPPING STALACTITE THAT IS CONNECTED WITH A LATTICEWORK OF CHAIN. THE INVERTED CONICAL FORM GIVES THE ART PIECE A WEIGHTLESS, FLOATING QUALITY. ILLUMINATED BY A SPIRALLING ARRANGEMENT OF GLASS BALLS CONTAINING G9 HALOGEN LAMPS. AVAILABLE IN TWO SIZES.

MODEL	SHADE SIZE	TOTAL HEIGHT
DROPLET - 1000	1000W X 2430 MM	2700MM
DROPLET - 700	700W X 1900H MM	2150MM

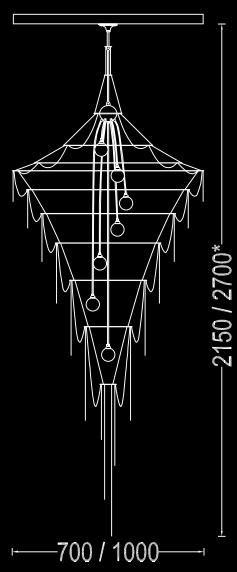



THE ENCHANTED FARAWAY TREE



THE ENCHANTED FARAWAY TREE

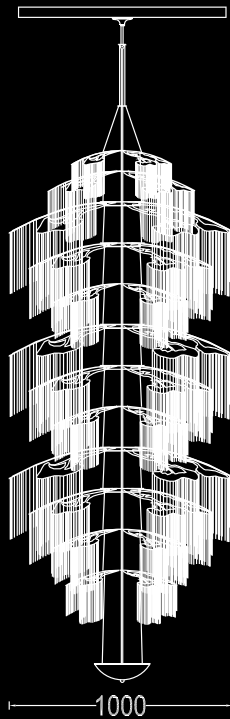

DESCRIPTION
 AN EVOLUTION OF THE AWARD-WINNING FARAWAY TREE WHICH HAS BEEN TRANSFORMED INTO A SUSPENDED SCULPTURAL MOBILE. THIS DESIGN IS DERIVED FROM A SERIES OF COUNTERBALANCING, BOWING BRANCHES ALL SUSPENDED FROM ONE ANOTHER AND FLOWING DOWN A CENTRAL 'TRUNK'. IT CAN BE ORDERED IN CLUSTERS OF FOUR BRANCHES E.G., 4 TIER, 8 TIER, 12 TIER OR MORE. IT COULD BE A MAGNIFICENT ADDITION TO A 10-15 STOREY VOID INSIDE A SPIRAL STAIRWAY.

4 TIER
 8 TIER
 12 TIER



MODEL	SHADE SIZE	TOTAL HEIGHT
ENCHANTED FARAWAY TREE - 12 TIER - 1000	1000W X 2800H MM	3250MM
ENCHANTED FARAWAY TREE - 8 TIER - 1000	1000W X 2000H MM	2450MM
ENCHANTED FARAWAY TREE - 4 TIER - 1000	1000W X 1300H MM	1600MM





ELONGATED
FARAWAY TREE
CHANDELIER





ELONGATED FARAWAY TREE CHANDELIER

DESCRIPTION

AN EVOLUTION OF OUR ORIGINAL 'ROUND SHAPED' FARAWAY TREE, AN ORGANIC 'TREE-SHAPED' CHANDELIER INSPIRED BY GRAPHIC REPRESENTATIONS OF TREES ON ARCHITECTURAL DRAWINGS. ILLUMINATED BY 3 CLUSTERS OF G4 HALOGEN/LED'S IN SUSPENDED GLASS BALLS.

MODEL	SHADE SIZE	TOTAL HEIGHT
FARAWAY TREE - ELONGATED - 1600X700	1600X700W X 530H MM	1000MM

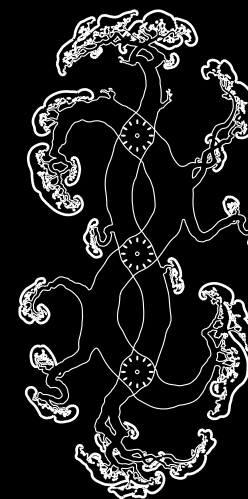
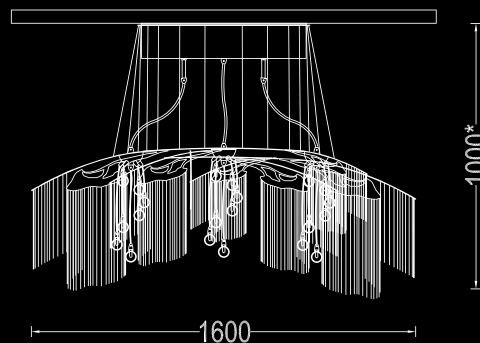

SPIRAL TREES





SPIRAL TREES

DESCRIPTION

A DESIGN WHICH IS BASED ON PART OF A MASSIVE TREE FOREST INSTALLATION IN A PRIVATE HOME IN LONDON. THIS IS AN EVOLUTION OF OUR ENCHANTED FARAWAY TREE WHICH FUSES ALL THE BRANCHES INTO A SINGLE ELEGANT SPIRALLING FRAME.



MODEL	SHADE SIZE	TOTAL HEIGHT
SINGLE SPIRAL TREE - SUSPENDED	1500W X 2200H MM	3200MM
DOUBLE SPIRAL TREE - SUSPENDED	1200X2000 X 1500H MM	2200MM

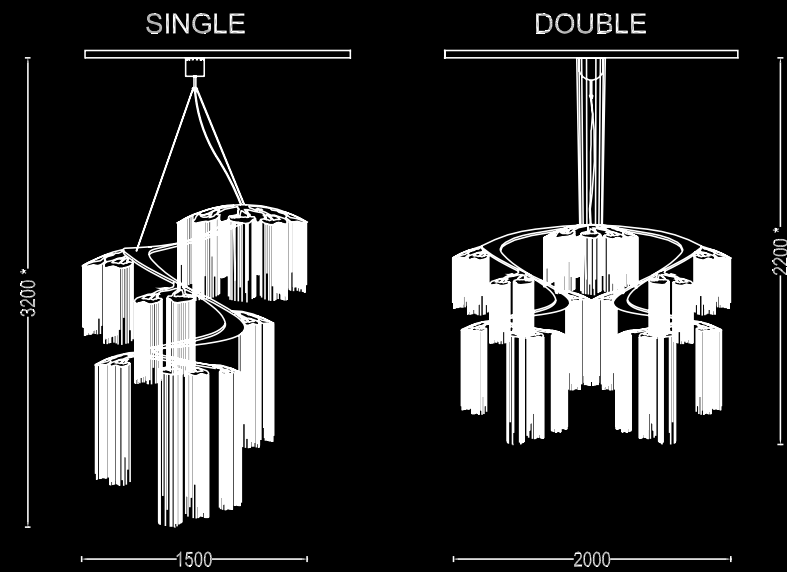

COMPLEX CLASSICS

CHANDELIERS AND WALL SCONCES



COMPLEX CLASSICS

CHANDELIERS AND WALL SCONCES

For the 99 percent of the time we've been on Earth, we were hunters and gatherers, our lives dependent on knowing the fine, small details of our world. Deep inside, we still have a longing to be reconnected with the nature that shaped our imagination, our language, our song and dance, our sense of the divine. Janine M. Benyus





COCOON





COCOON

DESCRIPTION

COCOON IS AN ELONGATED, SLEEK AND MINIMALLY STYLED 'POD SHAPED' CHANDELIER SUITABLE FOR A LINEAR SPACE OR OVER A TABLE / COUNTERTOP. ILLUMINATED BY 9X G9 HALOGEN OR LED LAMPS WITHIN HANDMADE CLEAR PYREX GLASS BALLS WITH OR BY 9X E27 VINTAGE STYLE LED BULBS.

MODEL	SHADE SIZE	TOTAL HEIGHT
COCOON - SUSPENDED - 1750X400	1750X400W X 400H MM	1000MM

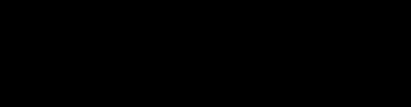
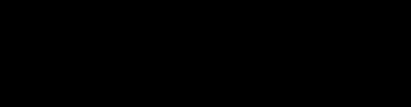
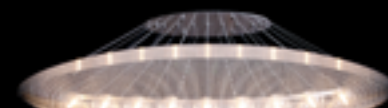
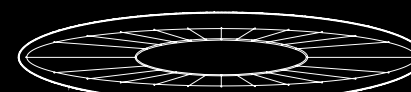



STREAMWAVE





STREAMWAVE

DESCRIPTION

STREAMWAVE IS A VERY UNUSUAL DYNAMIC PIECE THAT PLAYS WITH ONE'S PERCEPTION AS IT APPEARS TO TRANSFORM FROM DIFFERENT VIEWPOINTS IN SUBTLE WAYS. THE DESIGN IS COMPOSED OF STAGGERED WAVES WHICH EVOKE A SUBTLE FEELING OF RHYTHMIC MOVEMENT. ILLUMINATED BY 20X G4 LEDS.

MODEL

SHADE SIZE

TOTAL HEIGHT

STREAMWAVE - 1200MM - SUSPENDED

1200X400W X 220H MM

700MM

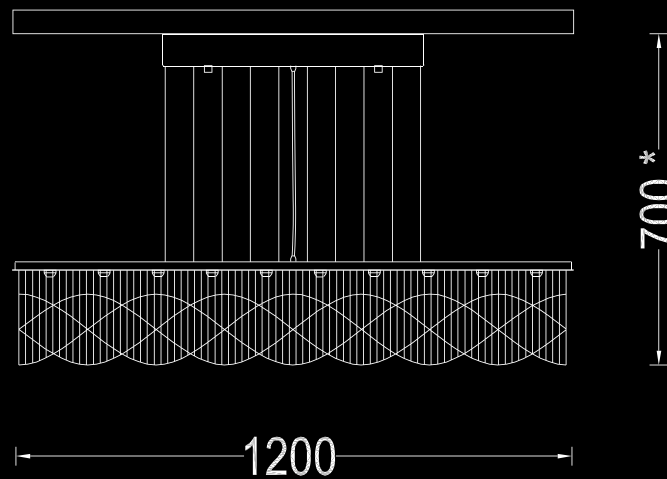



RADIAL





RADIAL

DESCRIPTION

RADIAL IS THE ULTIMATE RING SHAPED CHANDELIER AND IS ESSENTIALLY AN EXTENSION OF THE 'LINEAL RANGE' AS THE 'ROUND' VERSION. AS WITH THE LINEAL, THE CONCEPT IS A TEXTURED GRID WITH LAYERS OF DIFFERENT COLOURED METALLIC CHAINS FORMING A MODULAR MATRIX. THIS PIECE IS 1.2M DIAMETER AND IS ILLUMINATED BY 56X 1 OR 2W G4 LED'S. IT WILL SOON BE AVAILABLE AVAILABLE IN 2 SMALLER STANDARD SIZES.



MODEL	SHADE SIZE	TOTAL HEIGHT
RADIAL - 1200MMD - SUSPENDED	1200DIA X 90H MM	550MM

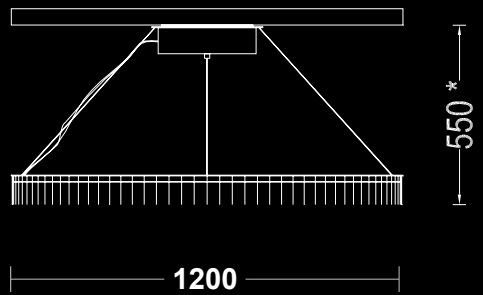
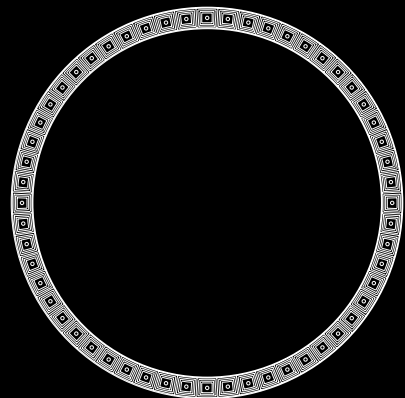

LINEAL



LINEAL

DESCRIPTION

A VERY SLEEK AND MINIMAL LAMP INTENDED FOR A FUNCTIONAL WORKING SPACE SUCH AS AN OFFICE OR ABOVE A POOL TABLE WHERE A LARGE POOL OF LIGHT IS REQUIRED TO PERFORM TASKS. FEATURES A DECORATIVE 'TEXTURE PLANE' THAT HAS A 'TEXTILE' QUALITY WITH A COMPACT MATRIX OF LED LAMPS. DESIGNED BY ADAM HOETS IN 2019.



No.1

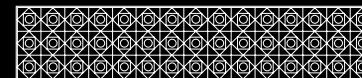

No.2

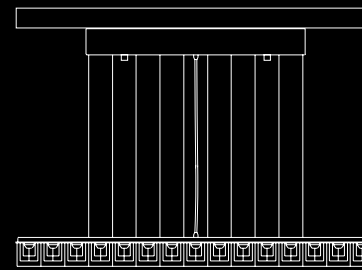
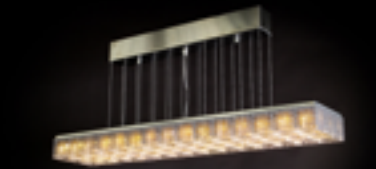

600*

900

MODEL	SHADE SIZE	TOTAL HEIGHT
LINEAL NO.1 - SUSPENDED - 900X180	900X200W X 180H MM	600MM
LINEAL NO.2 - SUSPENDED - 900X180	900X200W X 180H MM	600MM





WINDCHIME





WINDCHIME

DESCRIPTION
A POETIC INTERPRETATION OF TRADITIONAL BAMBOO WINDCHIME FORMS. THE DESIGN IS A CIRCULAR TIERED ARRANGEMENT OF REPEATED 'WINDCHIMES'. IT IS ILLUMINATED BY G4 LED'S IN EACH WINDCHIME AS WELL AS 6 LEDS ON TOP OF THE MAIN FRAME WHICH ILLUMINATE AND CAST DRAMATIC SHADOWS ONTO THE CEILING.

MODEL	SHADE SIZE	TOTAL HEIGHT
WINDCHIME - SUSPENDED - 700	700W X 1820 MM	2320MM

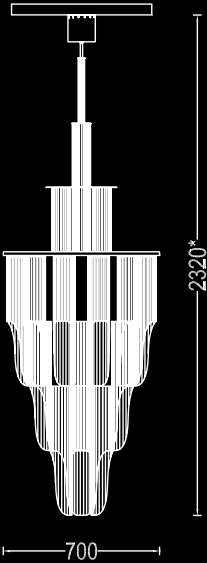
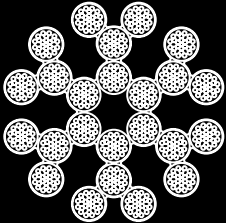

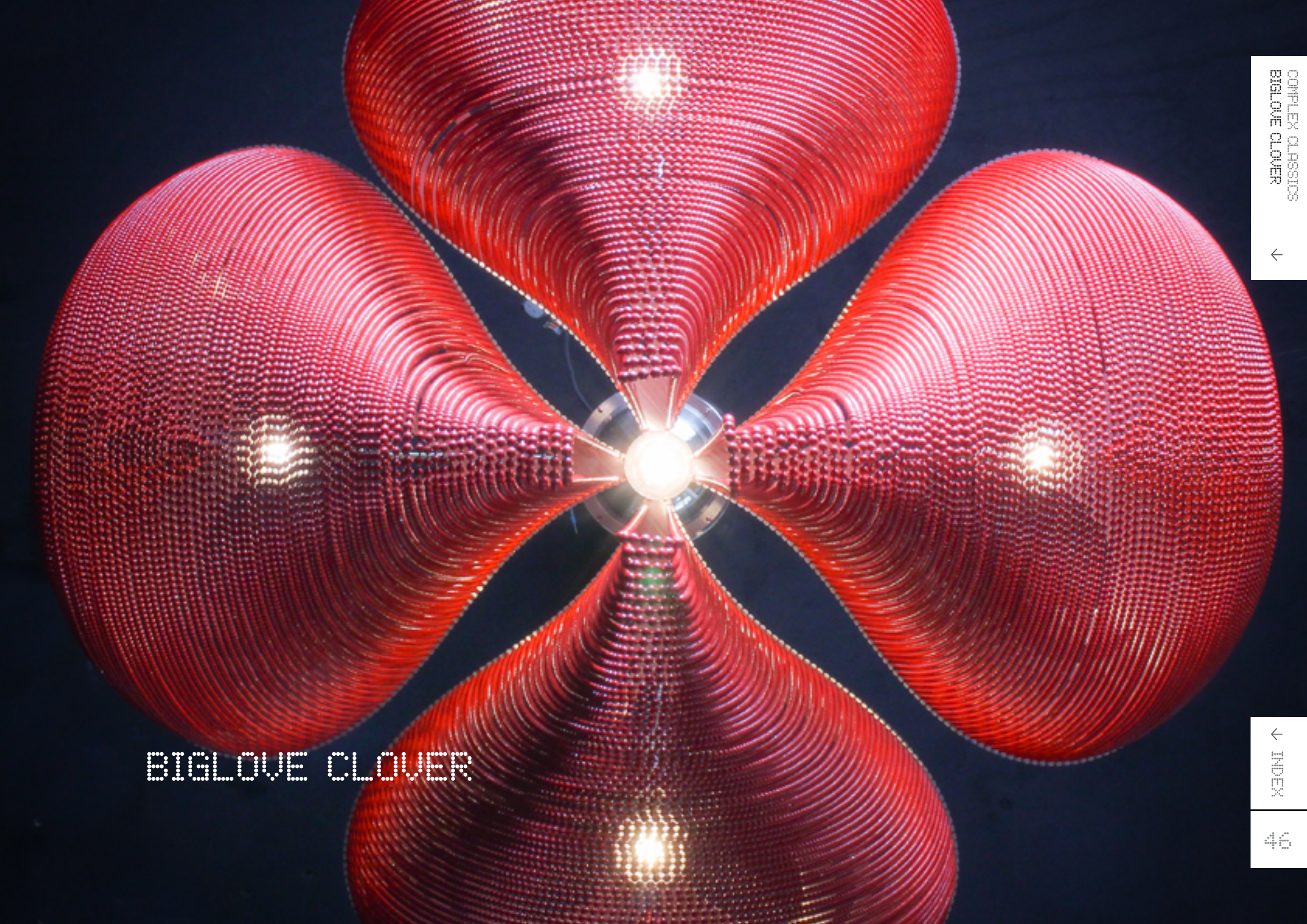

BIGLOVE CLOVER





BIGLOVE CLOVER

DESCRIPTION

A FOUR LEAF CLOVER DESIGN TRANSLATED INTO A VOLUPTUOUS AND SENSUAL HEART SHAPED CHANDELIER FORM. ILLUMINATED BY 5 G4 HALOGEN OR LED LAMPS IN SUSPENDED PYREX GLASS BALLS. ALSO AVAILABLE AS A WALL SCONCE.

MODEL	SHADE SIZE	TOTAL HEIGHT
BIGLOVE CLOVER - SUSPENDED - 700	700W x 900H MM	1700MM
BIGLOVE CLOVER - WALL SCONCE - 300	300 X 275W MM	650MM

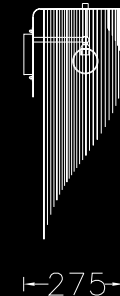
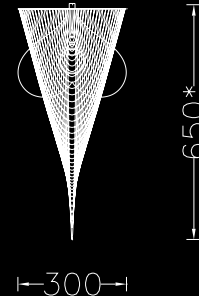
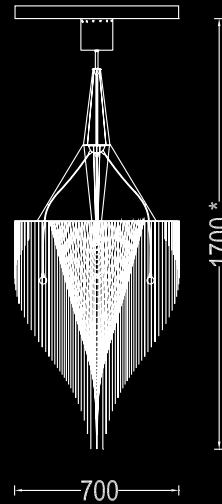
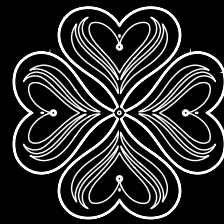



FARAWAY TREE





FARAWAY TREE

DESCRIPTION

AN ORGANIC 'TREE-SHAPED' CHANDELIER INSPIRED BY GRAPHIC REPRESENTATIONS OF TREES ON ARCHITECTURAL DRAWINGS. ILLUMINATED BY A CONCEALED LIGHT SOURCE WITHIN A SUSPENDED UP-LIGHTER DISH. AVAILABLE IN THREE SIZES AND AS A WALL SCONCE.

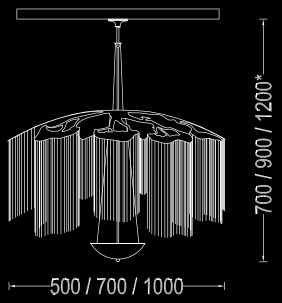
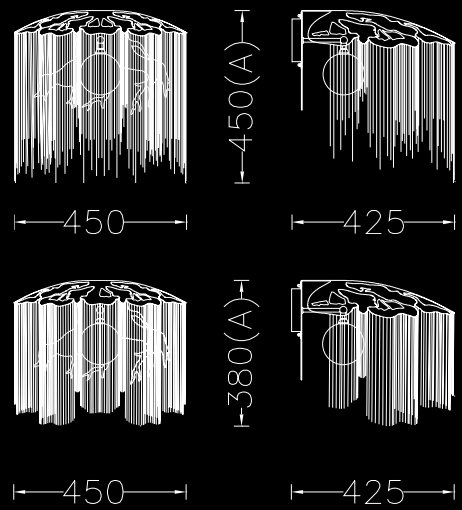

MODEL	SHADE SIZE	TOTAL HEIGHT	
FARAWAY TREE - 1000	1000W X 750H MM	1200MM	
FARAWAY TREE - 700	700W X 550H MM	900MM	
FARAWAY TREE - 500	500W X 400H MM	700MM	
FARAWAY TREE - 450 - WALL SCONCE	450 X 425W MM	380-450MM	





FLOWER OF LIFE

Sacred geometry is the expression of geometry related to the evolution of consciousness, mind, body, and spirit in geometric terms. True sacred geometry is not just static angular forms. It is organic and living - it is in constant evolution (transcendence) or devolution (materialisation), ascending or descending from one form to another.

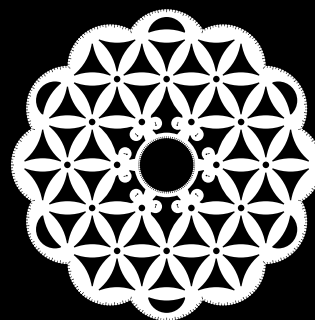



FLOWER OF LIFE

DESCRIPTION

THE ORIGINAL, ICONIC AWARD-WINNING WILLOWLAMP DESIGN, BASED ON THE SACRED GEOMETRY KNOWN AS THE 'FLOWER OF LIFE'. THIS IS AN ELEGANT AND INTRICATE MULTI-LEVELLED CHANDELIER THAT EVOKES A CLASSIC 1920S STYLE. THIS DESIGN HAS BEEN COVERED BY A ETL RATING FOR THE USA AND CANADA. IT IS AVAILABLE AS BOTH A CEILING MOUNTED OR SUSPENDED MODEL IN THREE SIZES AND AS A WALL SCONCE.

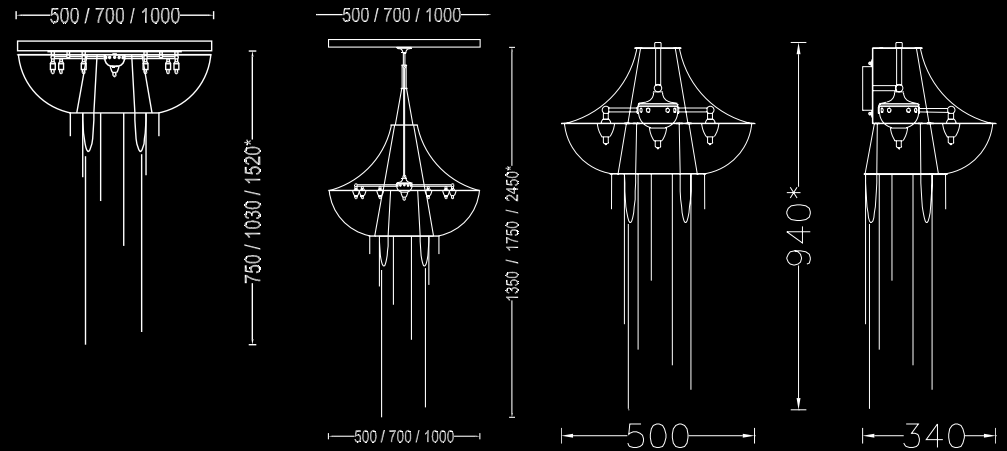
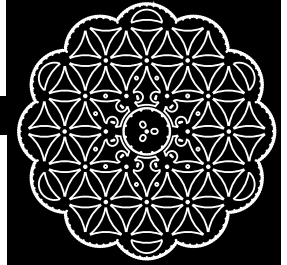

MODEL	SHADE SIZE	TOTAL HEIGHT	
FLOWER OF LIFE - 1000 - SUSPENDED	1000W X 1175H MM	2450MM	
FLOWER OF LIFE - 700 - SUSPENDED	700W X 825H MM	1750MM	
FLOWER OF LIFE - 500 - SUSPENDED	500W X 630H MM	1350MM	
FLOWER OF LIFE - 1000 - CEILING MOUNTED	1000W X 520H MM	1520MM	
FLOWER OF LIFE - 700 - CEILING MOUNTED	700W X 400H MM	1030MM	
FLOWER OF LIFE - 500 - CEILING MOUNTED	500W X 275H MM	750MM	
FLOWER OF LIFE - 500 - WALL SCONCE	500 X 340W MM	940MM	





PROTEA

PROTEA CHANDELIER & WALL SCONCE

DESCRIPTION

AN ICONIC CHANDELIER IN THE FORM OF THE PROTEA, SOUTH AFRICA'S NATIONAL FLOWER. DESIGNED USING SACRED GEOMETRY, THE CREATION IS CHARACTERISED BY MULTIPLE TIERS WITH THE CHAIN HUNG IN LAYERS OF LOOPEO 'PETALS'. THIS DESIGN HAS BEEN COVERED BY A ETL RATING FOR THE USA AND CANADA. IT IS AVAILABLE AS BOTH A CEILING MOUNTED OR SUSPENDED MODEL IN THREE SIZES.

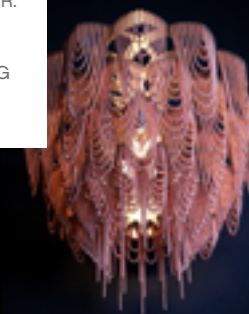
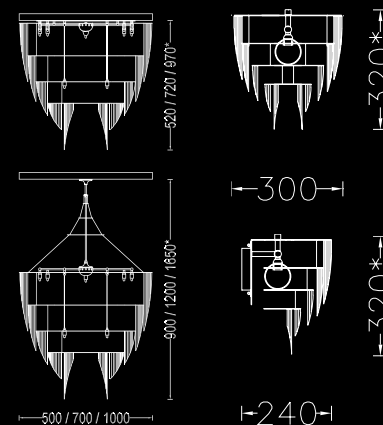
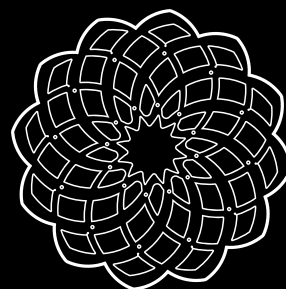

MODEL	SHADE SIZE	TOTAL HEIGHT	
PROTEA - 1000 - SUSPENDED	1000W X 950H MM	1650MM	
PROTEA - 700 - SUSPENDED	700W X 700H MM	1200MM	
PROTEA - 500 - SUSPENDED	500W X 500H MM	900MM	
PROTEA - 1000 - CEILING MOUNTED	1000W X 950H MM	970MM	
PROTEA - 700 - CEILING MOUNTED	700W X 700H MM	720MM	
PROTEA - 500 - CEILING MOUNTED	500W X 500H MM	520MM	
PROTEA - 300 - WALL SCONCE	300 X 320W MM	320MM	



FUSCHIA CHANDELIER

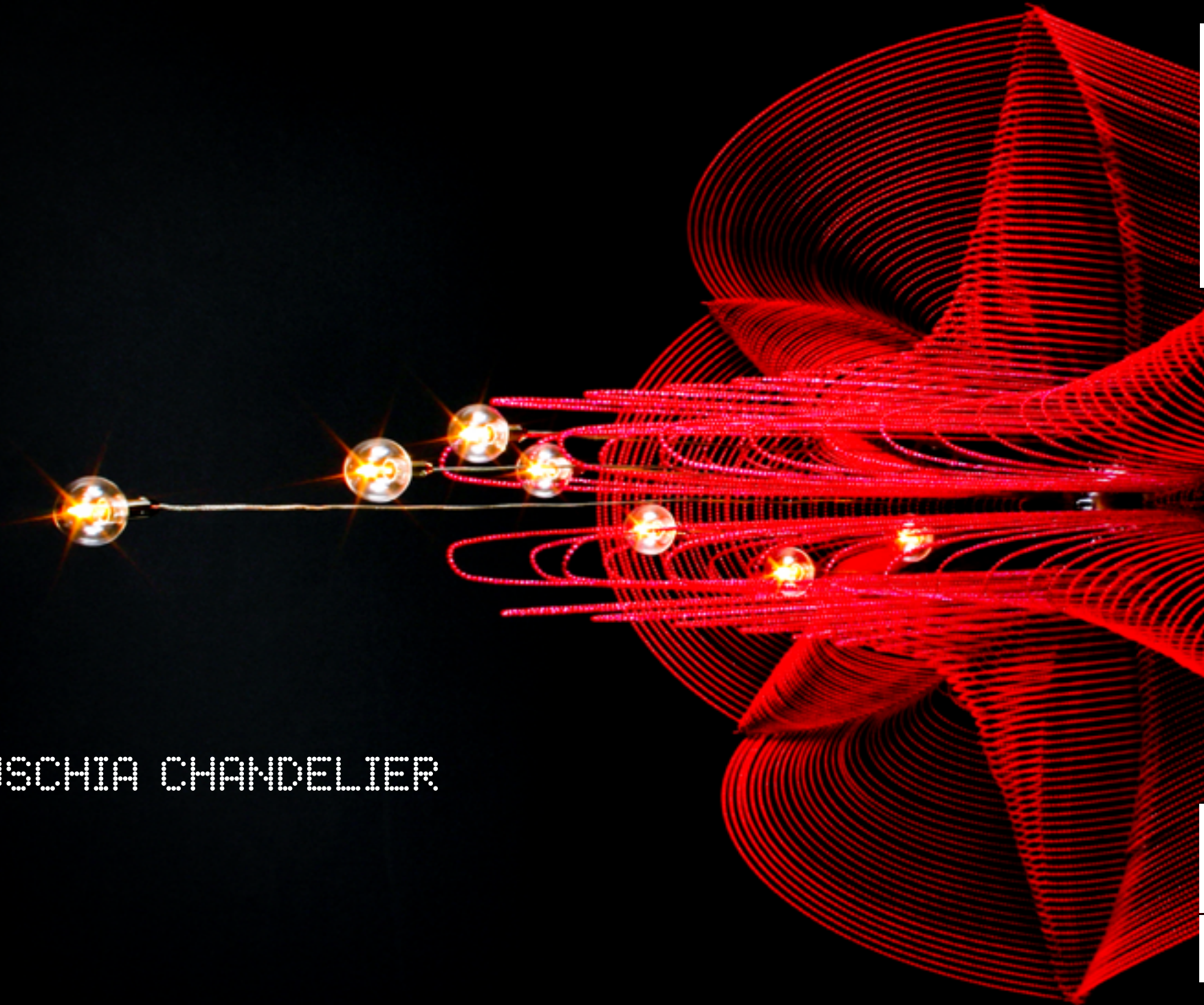



FUSCHIA CHANDELIER

DESCRIPTION

A CHANDELIER DESIGN BASED ON THE FORM OF DANGLING FUSCHIA FLOWERS WITH THE METAL 'PETALS' BOWING UNDER THE WEIGHT OF THE CHAIN. ILLUMINATED BY A SUSPENDED SPIRALLING ARRANGEMENT OF PYREX GLASS BALLS CONTAINING G4-HALOGEN 20 WATT 12V LAMPS. THIS DESIGN HAS AN ETL RATING FOR THE USA AND CANADA. AVAILABLE IN TWO SIZES.

MODEL	SHADE SIZE	TOTAL HEIGHT
FUSCHIA - 1000	1000W X 1000H MM	1500MM
FUSCHIA - 700	700W X 700H MM	1150MM

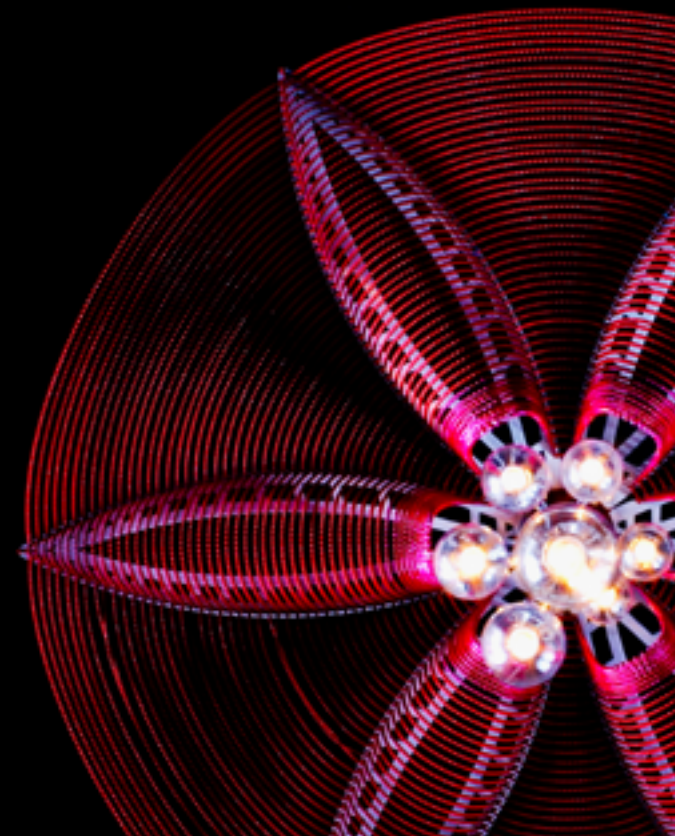
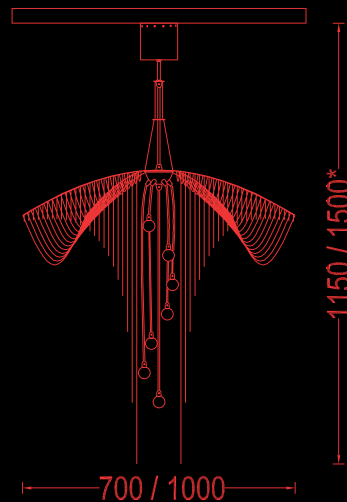
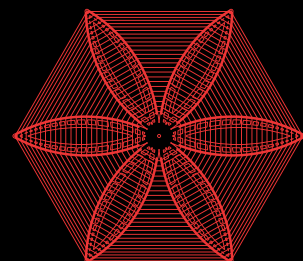

MOONFLOWER CHANDELIER

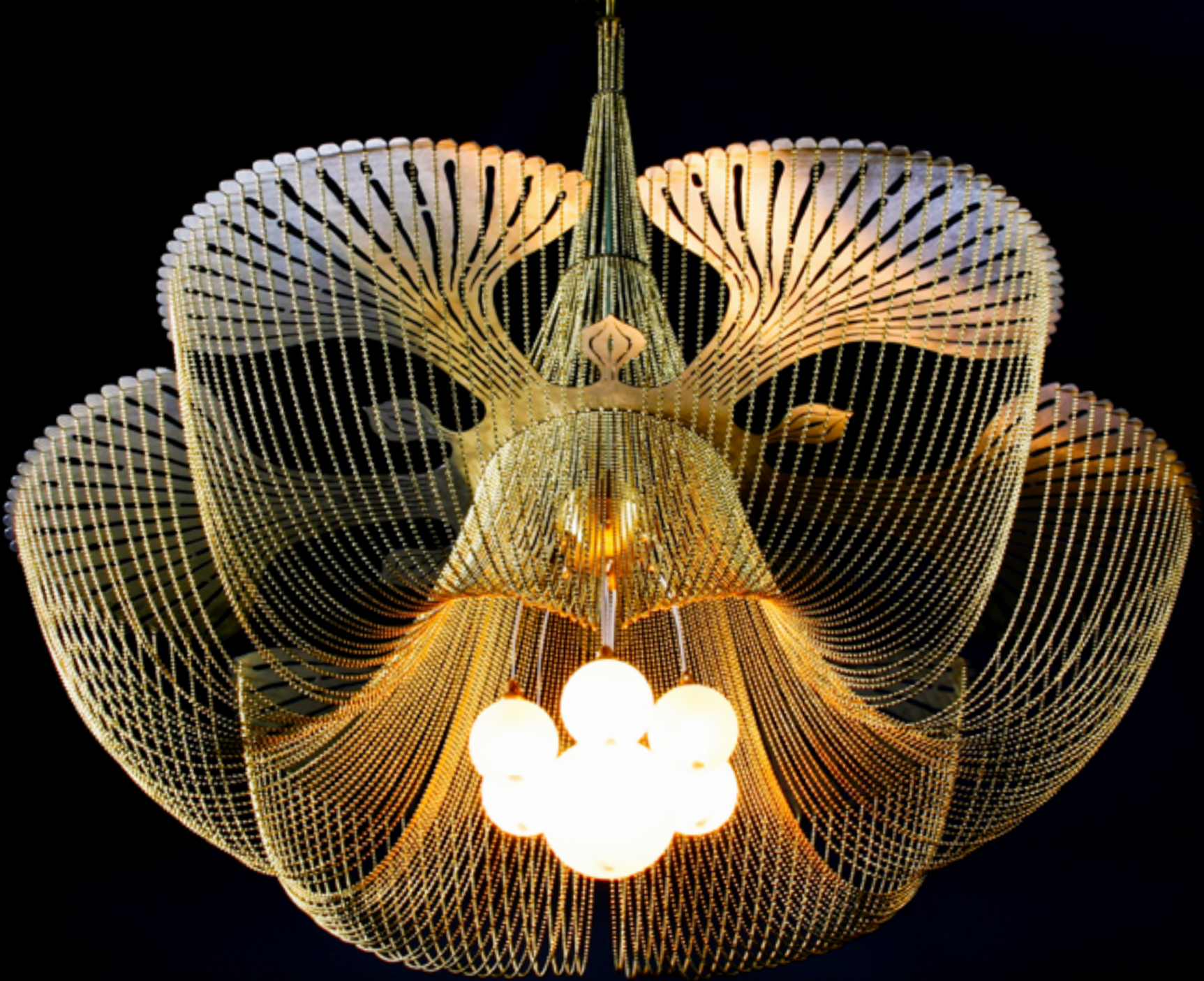



MOONFLOWER CHANDELIERS



DESCRIPTION

A WHIMSICAL CHANDELIER DESIGN BASED ON THE HANGING FLOWER FORM OF THE MOONFLOWER. THE 'PETALS' ARE DEFINED BY VOLUPTUOUS BALLCHAIN LOBES. ILLUMINATED BY A CLUSTER OF STAMEN-LIKE FROSTED PYREX GLASS VISORS CONTAINING G9 HALOGEN LAMPS. THIS DESIGN HAS BEEN COVERED BY AN ETL RATING FOR THE USA AND CANADA. AVAILABLE IN THREE SIZES.

MODEL	SHADE SIZE	TOTAL HEIGHT
MOONFLOWER - 1000	1000W X 830H MM	1150MM
MOONFLOWER - 700	700W X 580H MM	950MM
MOONFLOWER - 500	500W X 450H MM	800MM

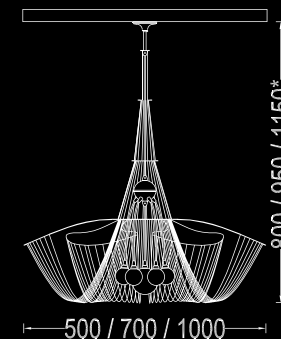
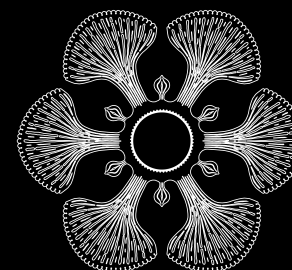
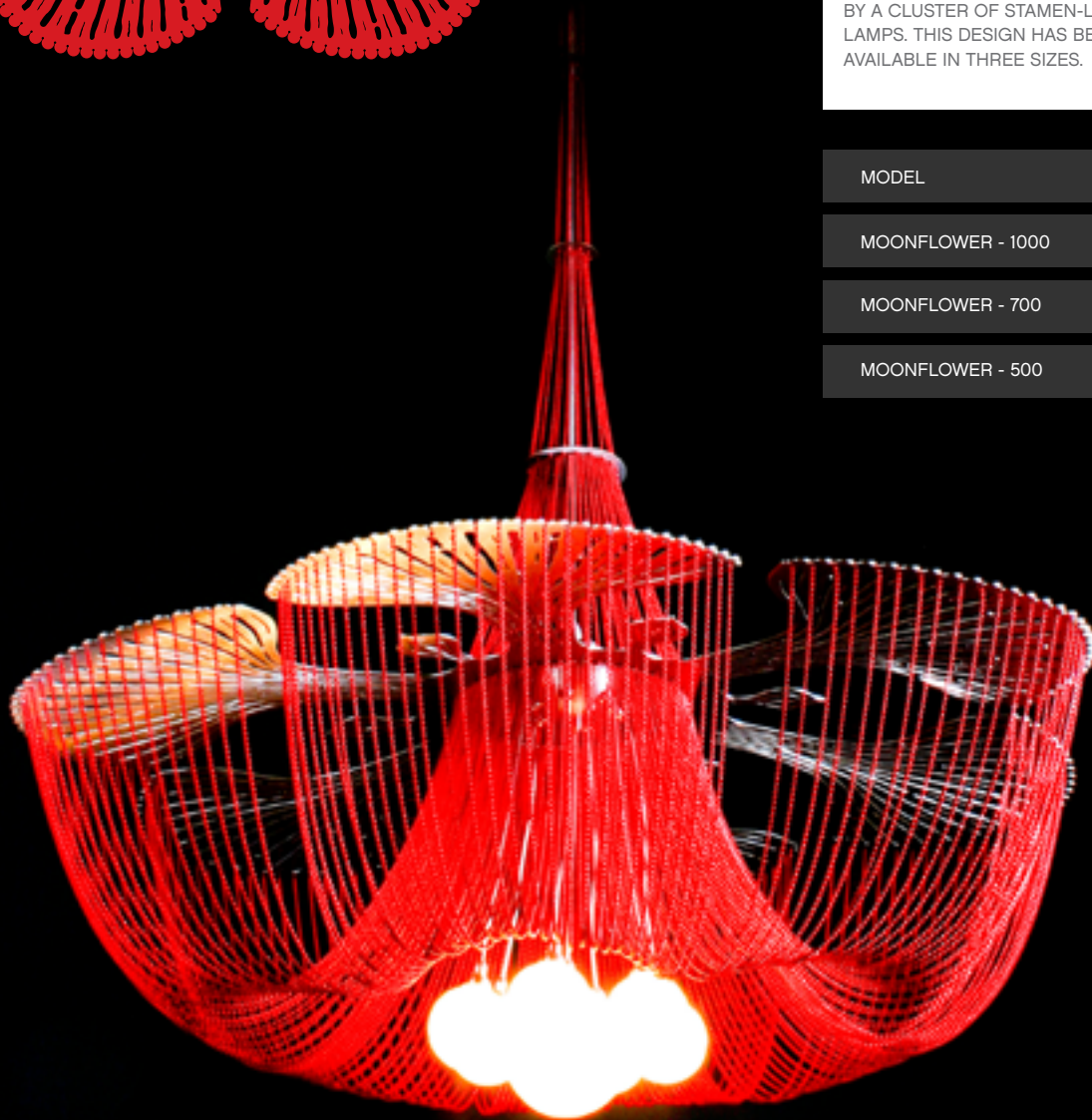



ROSE CHANDELIER





ROSE CHANDELIER

DESCRIPTION

A HI-TECH PLATE CHANDELIER WITH CHAIN CURTAINS AS 'PETALS' ARRANGED IN A LAYERED FORMATION IN THE SHAPE OF A ROSE. IT CAN BE ORDERED IN TWO STYLES: STRAIGHT OR LOOPED. IT IS AVAILABLE AS BOTH A CEILING MOUNTED OR SUSPENDED MODEL. CURRENTLY AVAILABLE IN G4-HALOGEN ONLY. A VERSION WITH INBUILT RECESSED LED LAMPS IS CURRENTLY IN DEVELOPMENT.

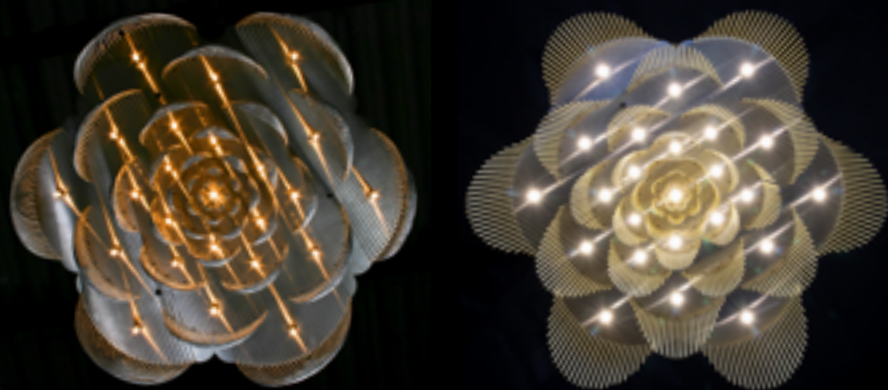
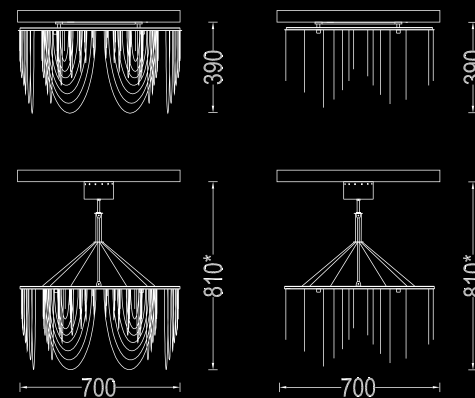
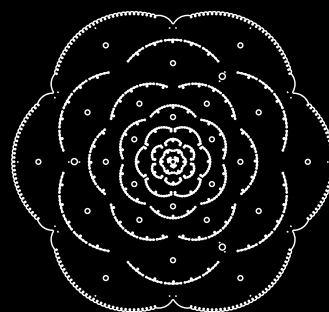

MODEL	SHADE SIZE	TOTAL HEIGHT	
ROSE - 700 - SUSPENDED - LOOPED	700W X 360H MM	810MM	
ROSE-700 - SUSPENDED - STRAIGHT	700W X 360H MM	810MM	
ROSE-700 - CEILING MOUNTED - LOOPED	700W X 370H MM	390MM	
ROSE - 700 - CEILING MOUNTED - STRAIGHT	700W X 370H MM	390MM	





NGOMA DRUM CHANDELIER





NGOMA DRUM CHANDELIER

DESCRIPTION

A CYLINDRICAL DRUM-SHAPED CHANDELIER WITH A SUPPORT FRAME INSPIRED BY VENETIAN WROUGHT IRON DESIGN. ILLUMINATED BY A SUSPENDED ARRANGEMENT OF PYREX GLASS BALLS CONTAINING G4-HALOGEN LAMPS. AVAILABLE IN TWO SIZES.

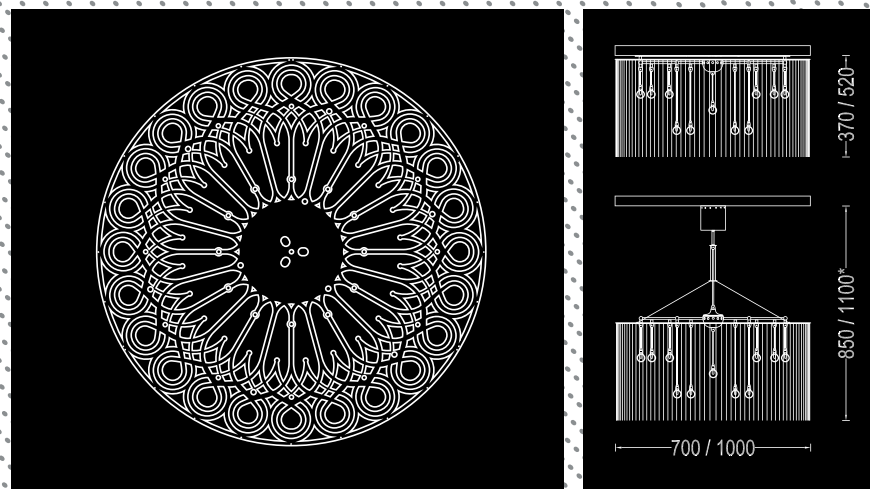

MODEL	SHADE SIZE	TOTAL HEIGHT	
NGOMA DRUM - 1000 - SUSPENDED	1000W X 500H MM	1100MM	
NGOMA DRUM - 700 - SUSPENDED	700W X 350H MM	850MM	
NGOMA DRUM - 1000 - CEILING MOUNTED	1000W X 500H MM	520MM	
NGOMA DRUM - 700 - CEILING MOUNT	700W X 350H MM	370MM	





THREE-TIERED CHANDELIER





THREE-TIERED CHANDELIER & WALL SCONCE

DESCRIPTION

OUR INTERPRETATION OF THIS CLASSIC MODERN CHANDELIER DESIGN. AN ARRANGEMENT OF THREE SEMI-TRANSPARENT CYLINDRICAL VOLUMES. ILLUMINATED BY G9-HALOGEN 25 WATT LAMPS. THIS DESIGN HAS BEEN COVERED BY A ETL RATING FOR THE USA AND CANADA. IT IS AVAILABLE AS BOTH A CEILING-MOUNTED OR SUSPENDED MODEL, IN THREE SIZES.

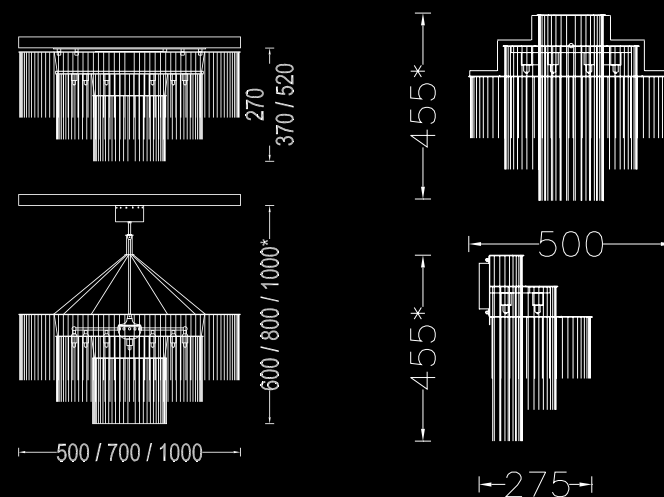
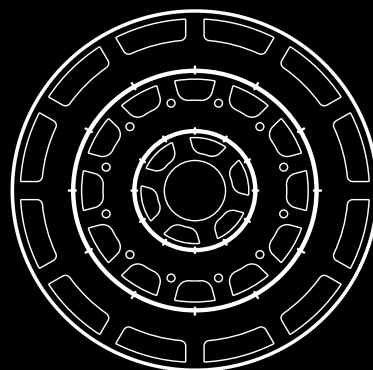
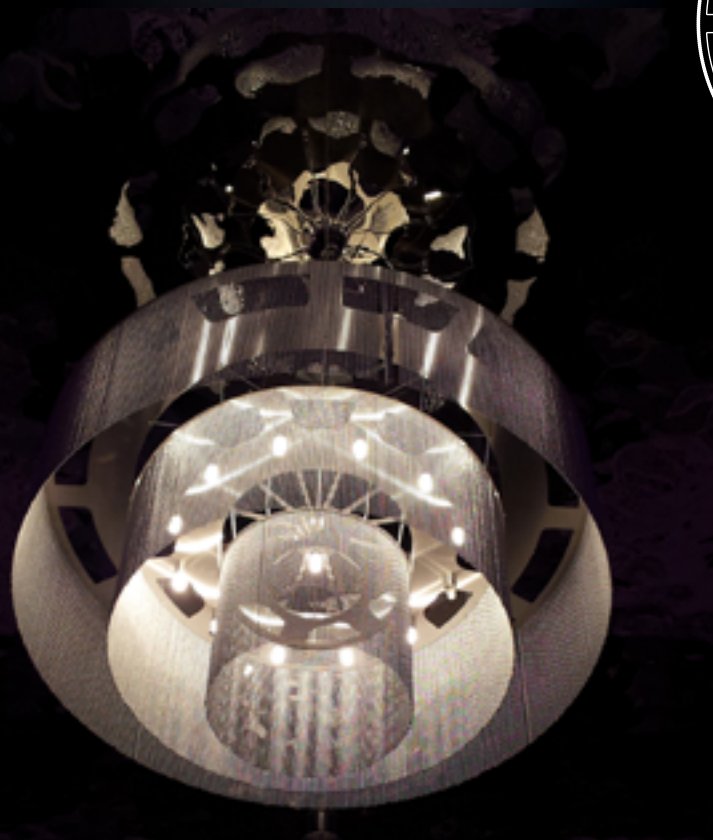

MODEL	SHADE SIZE	TOTAL HEIGHT	
3-TIER - 1000 - SUSPENDED	1000W X 500H MM	1000MM	
3-TIER - 700 - SUSPENDED	700W X 350H MM	800MM	
3-TIER - 500 - SUSPENDED	500W X 250H MM	600MM	
3-TIER - 1000 - CEILING MOUNTED	1000W X 500H MM	520MM	
3-TIER - 700 - CEILING MOUNTED	700W X 350H MM	370MM	
3-TIER - 500 - CEILING MOUNTED	500W X 250H MM	270MM	
3-TIER - 500 - WALL SCONCE	500 X 275W MM	455MM	







ELLIPTICAL
THREE-TIERED
CHANDELIER

ELLIPTICAL THREE-TIERED CHANDELIER

DESCRIPTION

A SUSPENDED OR CEILING-MOUNTED CHANDELIER BASED ON A MODERN CLASSIC CHANDELIER DESIGN WITH AN ARRANGEMENT OF THREE SEMI-TRANSPARENT ELLIPTICAL VOLUMES. MADE FROM LASER CUT STAINLESS STEEL FRAMES, CHROME PLATED OR LACQUERED, SOLID BRASS COMPONENTS AND BALLCHAIN IN SEVERAL OPTIONAL FINISHES. ILLUMINATED BY 12 SURFACE MOUNTED G9 HALOGEN OR LED LAMPS.

MODEL	SHADE SIZE	TOTAL HEIGHT	
ELLIPTICAL 3 TIER - 1600X600 - SUSPENDED	1600X600W X 500H MM	1000MM	
ELLIPTICAL 3 TIER - 1600X600 - CEILING MOUNTED	1600X600W X 500H MM	520MM	

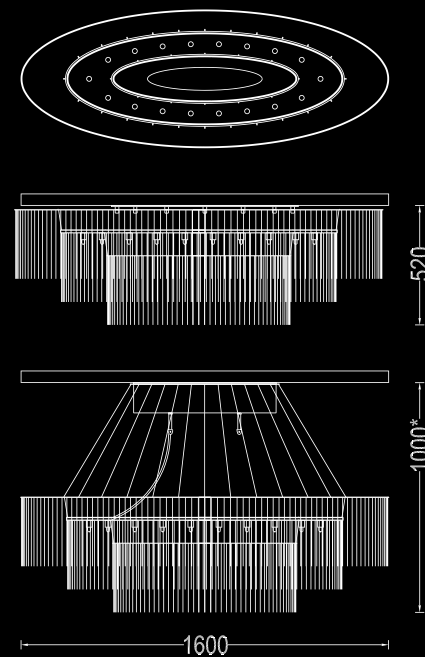

SIMPLE CLASSICS

PENDANTS AND WALL SCONCES



SIMPLE CLASSICS

FENDANTS AND WALL SCONCES

In all things of nature there is something of the marvelous. Aristotle





HALFPIPE

HALFPIPE WALL SCONCE

DESCRIPTION

AN ELEGANT WALL-SCONCE IN THE FORM A PARABOLIC CURVED HALF-PIPE. DECEPTIVELY SIMPLE BUT IN REALITY EVERY PIECE OF CHAIN HAS TO BE CUT TO THE PERFECT LENGTH TO SIMULATE THE EFFECT OF ITS PERFECT YET SIMPLE FLUID FORM.

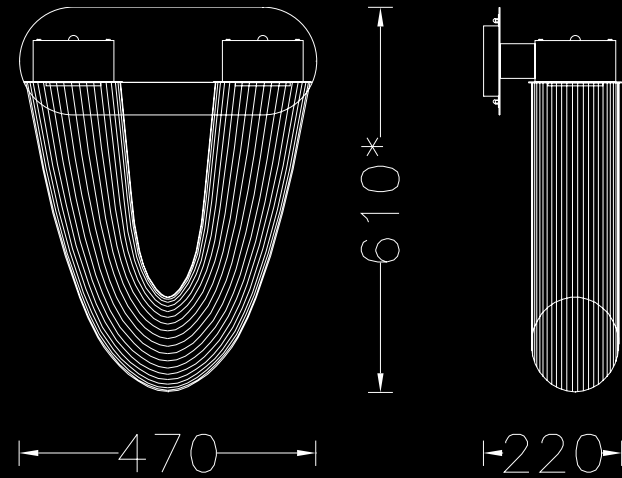

MODEL

SHADE SIZE

TOTAL HEIGHT

HALFPIPE - WALL SCONCE - 150

470 X 220W MM

610MM



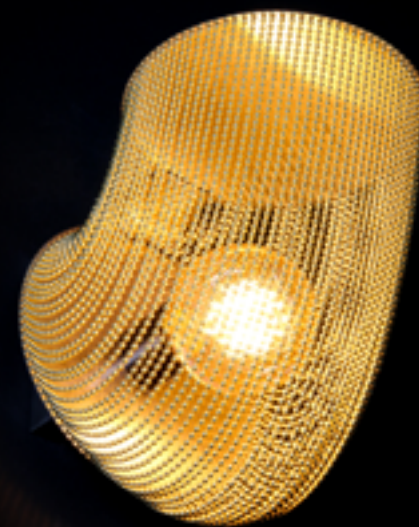

2 FOLDED
CIRCLES



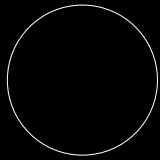

SOLID

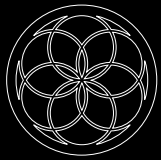

FLOWER OF LIFE

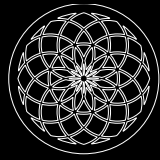

TORUS

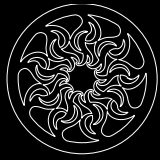

FLAME

2 FOLDED CIRCLES

DESCRIPTION

THE A COLLECTION OF WALL LAMPS THAT ARE BASED ENTIRELY ON JUST 2 SIMPLE CIRCLES FOLDED AT 90 DEGREES TO ONE ANOTHER. YET, THE RESULTING FORMS ARE SURPRISINGLY DIVERSE.

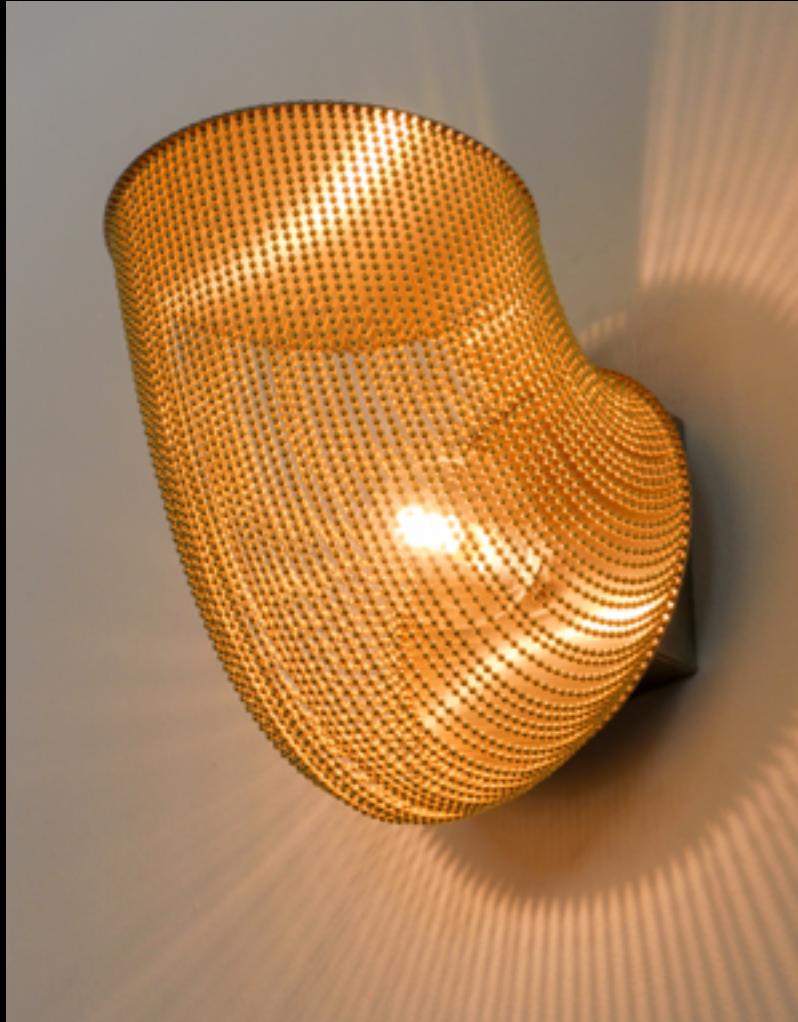

TOP FOLD

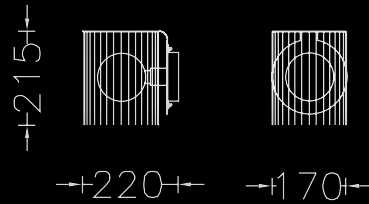

HALF PIPE

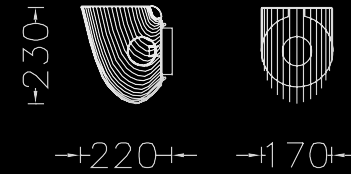

BOTTOM FOLD

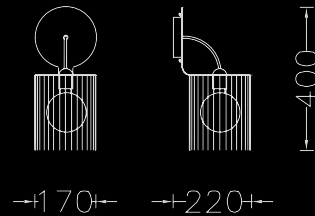

LANGARM

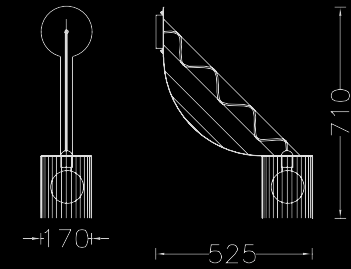

MODEL	SHADE SIZE	TOTAL HEIGHT	
QUARTERPIPE - WALL SCONCE - 170	170 X 220W MM	230MM	
TOPFOLD - WALL SCONCE - 170	170 X 220W MM	215MM	
BOTTOMFOLD - WALL SCONCE - 170	170 X 220W MM	400MM	
LANGARM - WALL SCONCE - 170	170 X 525W MM	710MM	



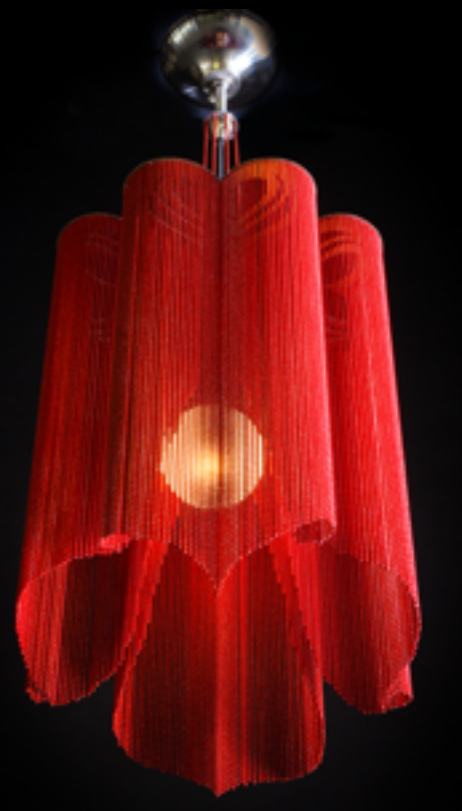

LOVE CLOWERS





LOVE CLOVERS

DESCRIPTION
 A FOUR LEAF CLOVER DESIGN TRANSLATED INTO A VOLUPTUOUS AND SENSUAL HEART SHAPED PENDANT LAMPS. ALSO AVAILABLE AS WALL LANTERNS.

MODEL	SHADE SIZE	TOTAL HEIGHT
BABYLOVE CLOVER- SUSPENDED - 250	250W X 300H MM	630MM
BABYLOVE CLOVER - WALL LANTERN - 250	250W X 300H MM	620MM
LUCKYLOVE CLOVER- SUSPENDED - 250	250W X 350H MM	680MM
SECRETLOVE CLOVER- SUSPENDED - 400	400W X 460H MM	840MM

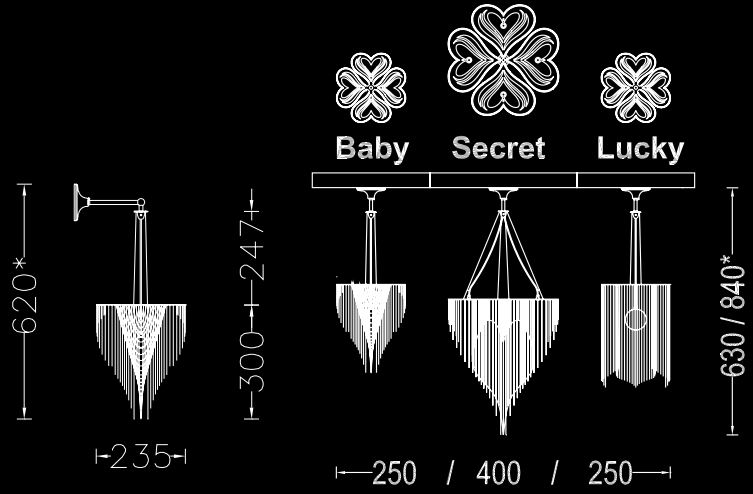



MOROCCAN VASES





MOROCCAN VASES

DESCRIPTION
 A COLLECTION OF PETITE LAMPS INSPIRED BY THE FORMS AND COLOURS OF MOROCCAN METAL VASES. ALSO AVAILABLE AS WALL LANTERNS.

MODEL	SHADE SIZE	TOTAL HEIGHT	
MOROCCAN VASE 1 - SUSPENDED - SML	330W X 660H MM	1000MM	
MOROCCAN VASE 1 - SUSPENDED - LRG	495W X 990H MM	1500MM	
MOROCCAN VASE 2 - SUSPENDED - SML	250W X 390H MM	730MM	
MOROCCAN VASE 2 - SUSPENDED - LRG	375W X 585H MM	1090MM	
MOROCCAN VASE 3 - SUSPENDED - SML	250W X 410H MM	750MM	
MOROCCAN VASE 3 - SUSPENDED - LRG	375W X 615H MM	1125MM	
MOROCCAN VASE 4 - SUSPENDED - SML	165W X 540H MM	880MM	
MOROCCAN VASE 4 - SUSPENDED - LRG	248W X 810H MM	1320MM	
MOROCCAN VASE 5 - SUSPENDED - SML	270W X 370H MM	710MM	
MOROCCAN VASE 5 - SUSPENDED - LRG	405W X 555H MM	1065MM	
MOROCCAN VASE 1 - WALL LANTERN - SML	330 X 350W MM	990MM	
MOROCCAN VASE 2 - WALL LANTERN - LRG	375 X 400W MM	1080MM	

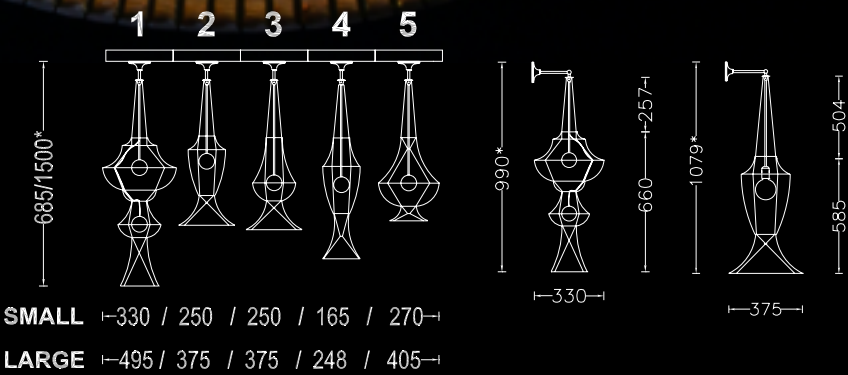



A-PEAL





A-PEAL

DESCRIPTION

A PLAYFUL RANGE OF LAMPS NAMED AFTER THE FACT THAT THE DESIGN IS DERIVED FROM THE OUTLINE OF A PEEL OF A CITRUS FRUIT.

MODEL	SHADE SIZE	TOTAL HEIGHT	
A-PEAL 1-TIER- SUSPENDED - 500	500W X 600H MM	950MM	
A-PEAL 2-TIER- SUSPENDED - 500	500W X 1600H MM	1950MM	

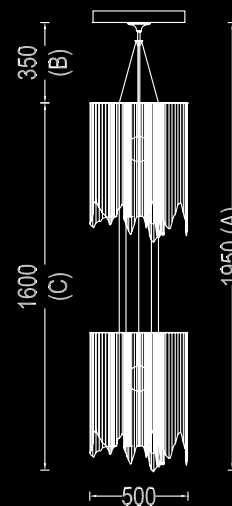
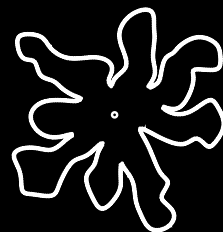
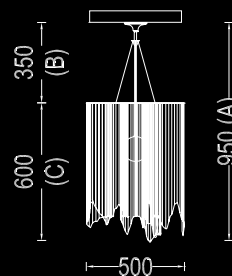

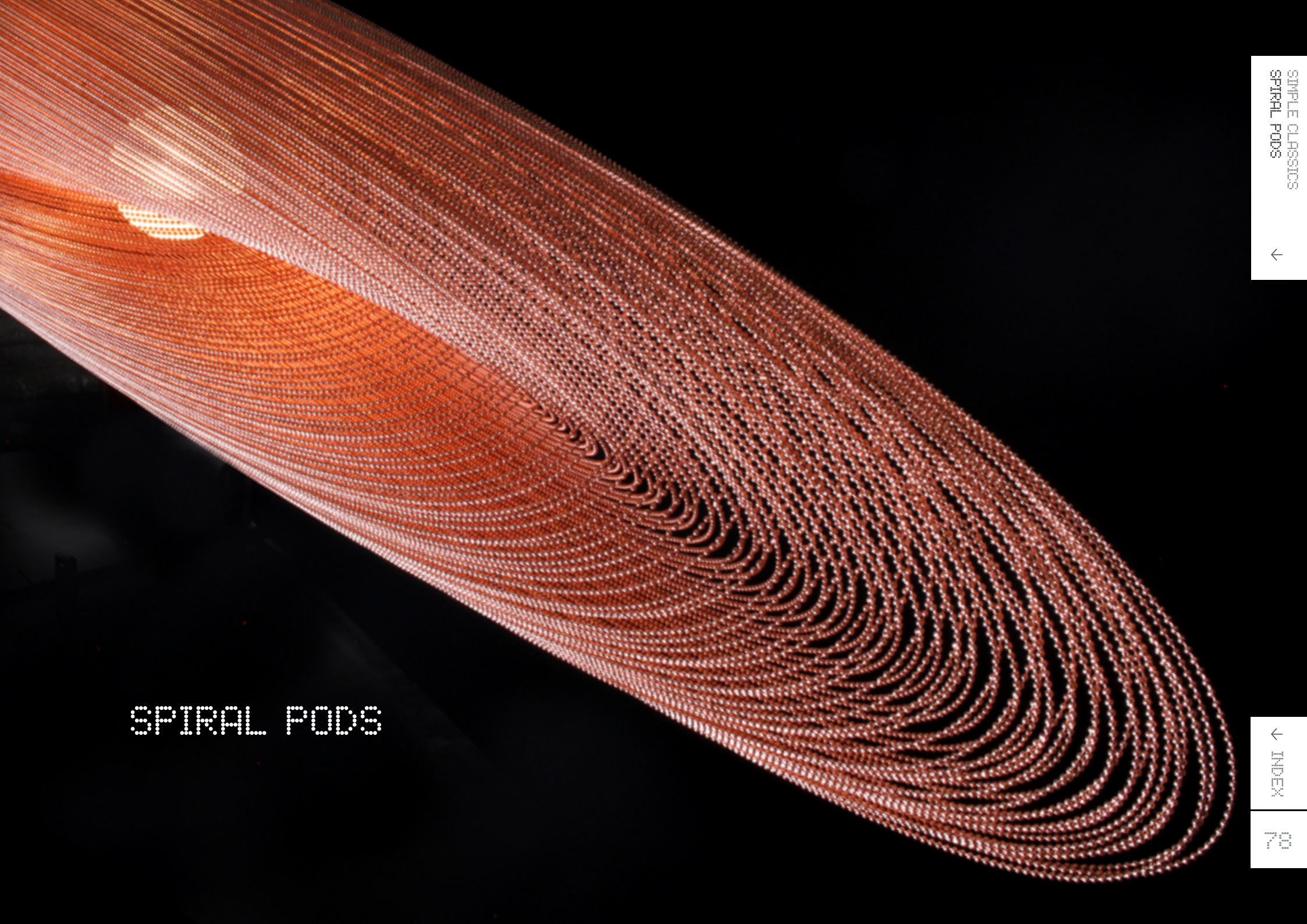

SPIRAL PODS





SPIRAL PODS

DESCRIPTION

A COLLECTION OF ELEGANT SPIRALING POD SHAPED LAMPS INSPIRED BY SPIRALING SHELLS. AVAILABLE AS A SINGLE OPEN SPIRAL OR A DOUBLE CLOSED SPIRAL WHICH WRAPS THROUGH ITSELF LIKE A 3D MOBIUS STRIP.

MODEL	SHADE SIZE	TOTAL HEIGHT	
SINGLE SPIRAL POD - SUSPENDED - 400	400W X 1400H MM	1900MM	
DOUBLE SPIRAL POD - SUSPENDED - 400	400W X 1400H MM	1900MM	

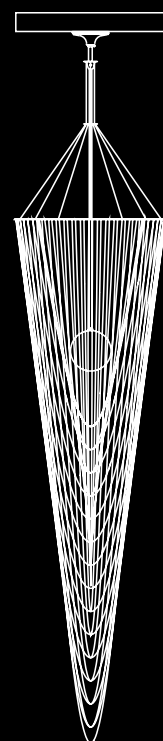

1900*

400



EXTRA LONG POD

SIMPLE CLASSICS
EXTRA LONG POD

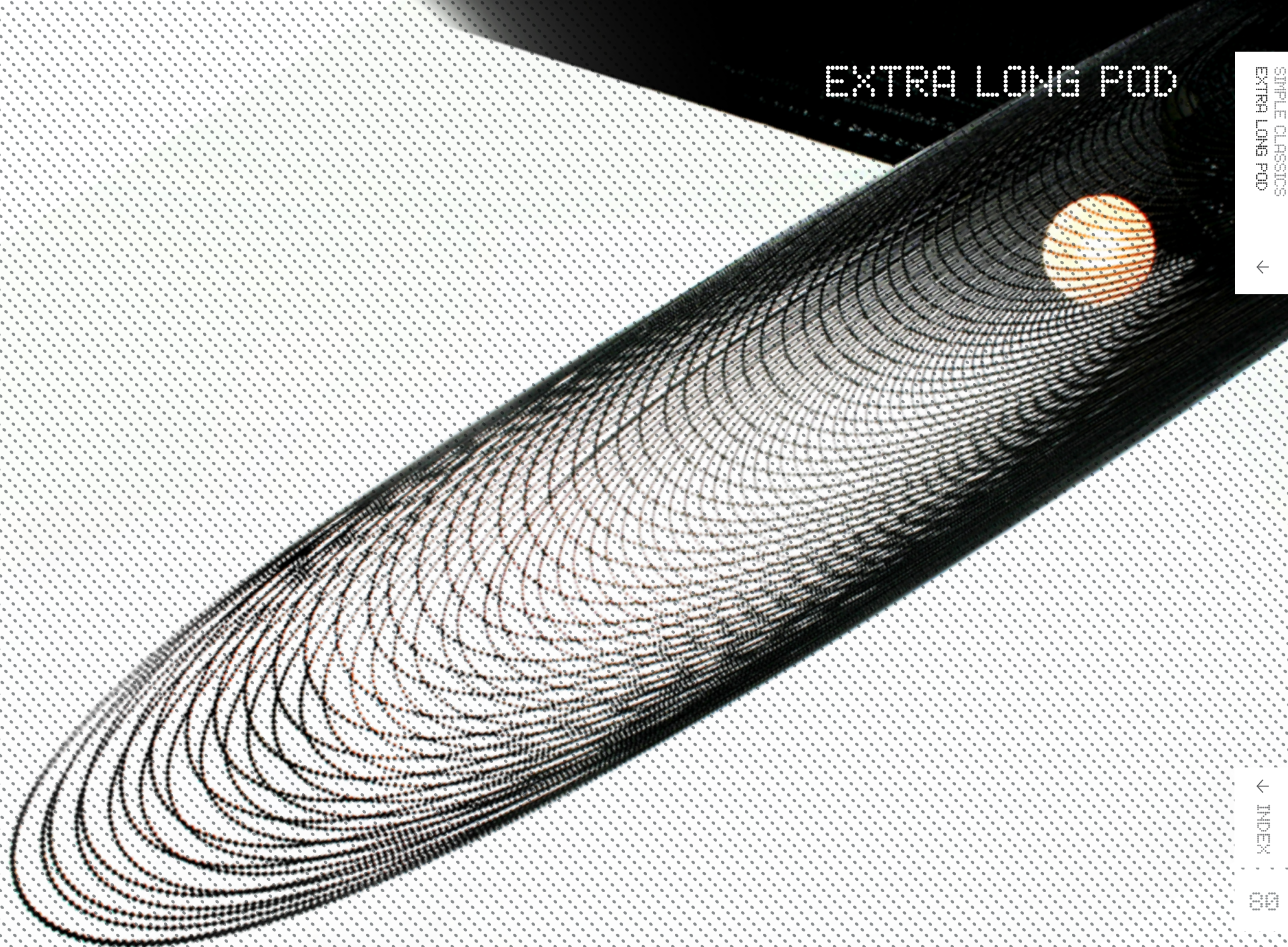

INDEX



00



EXTRA LONG POD

DESCRIPTION

A VERY LONG AND SLEEK POD-SHAPED PENDANT. ILLUMINATED BY A PYREX GLASS BALL CONTAINING A G9-HALOGEN LAMP.

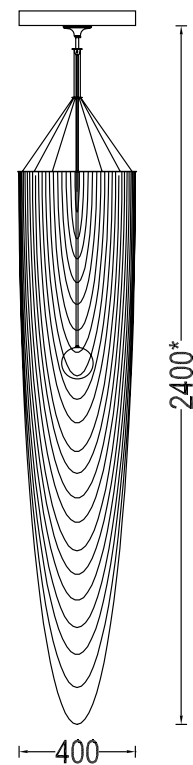
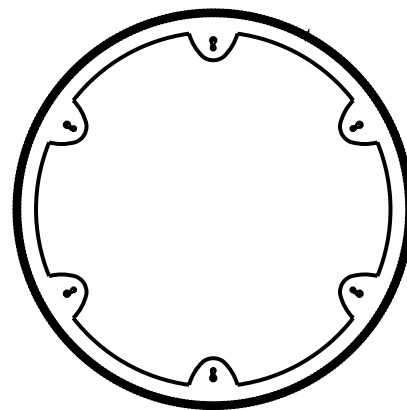

MODEL	SHADE SIZE	TOTAL HEIGHT
EXTRA LONG POD - 400	400W X 1900H MM	2400MM





LONG LANTERNS



LONG LANTERNS

DESCRIPTION

A SMALL FAMILY OF 150MM WIDE BY 1M LONG LANTERNS. THESE LAMPS ARE ESPECIALLY BEAUTIFUL BECAUSE THE LOW VOLTAGE DOWNLIGHTS CREATE THE EFFECT OF A SHAFT OF LIGHT AND THE LIGHT SOURCE DOES NOT DOMINATE. AVAILABLE IN THREE STYLE OPTIONS: CROPPED, WILLOWED OR POD.

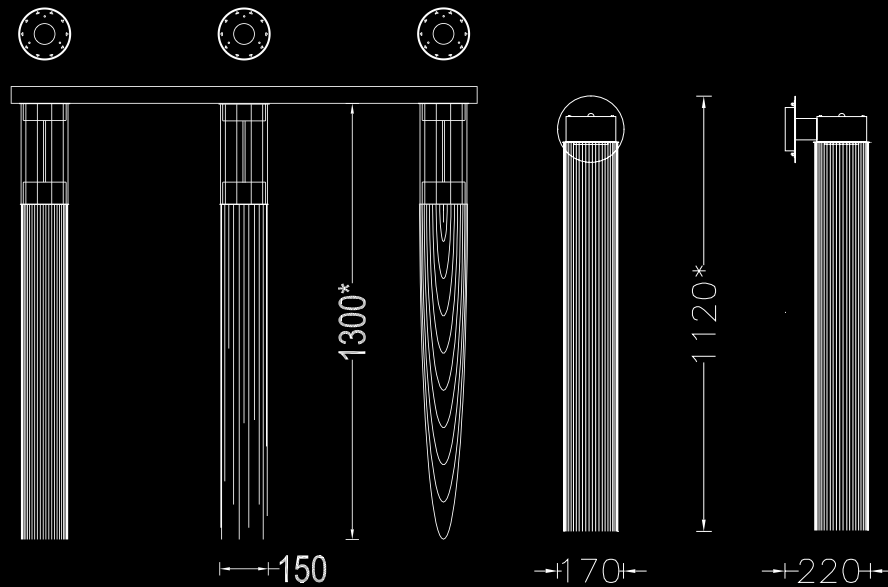

MODEL	SHADE SIZE	TOTAL HEIGHT
LONG LANTERN - 150	150W X 1000H MM	1300MM
LONG LANTERN - 150 - WALL SCONCE	150W X 1000H MM	170 X 220 X 1120 MM



SEEDS



Flowers always make people better, happier, and more helpful; they are sunshine, food and medicine for the soul.

Luther Burbank



CROCUS

DESCRIPTION

A 200MM WIDE PENDANT WITH LAYERED LOOPED CHAINS. INSPIRED BY FLOWER BUD FORMS. ILLUMINATED BY A PYREX GLASS BALL CONTAINING A G9-HALOGEN LAMP.

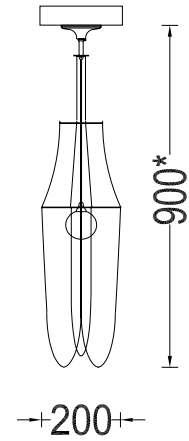
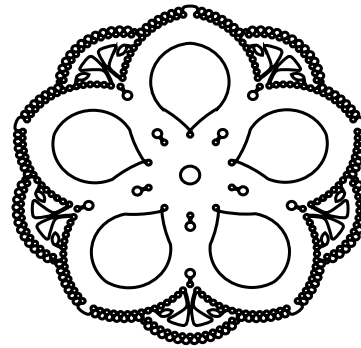

MODEL	SHADE SIZE	TOTAL HEIGHT
CROCUS - 200	200W X 650H MM	900MM





FRANZINI

FRANGIPANI

DESCRIPTION

A 400MM WIDE MINI-CHANDELIER PENDANT WITH OVERLAPPING LOOPEd CHAIN CURTAINS IN A 'GRENADE' PATTERN. INSPIRED BY THE SHAPE OF THE FRANGIPANI FLOWER. ILLUMINATED BY A PYREX GLASS BALL CONTAINING A G9-HALOGEN LAMP. THIS DESIGN HAS BEEN COVERED BY A ETL RATING FOR THE USA AND CANADA.

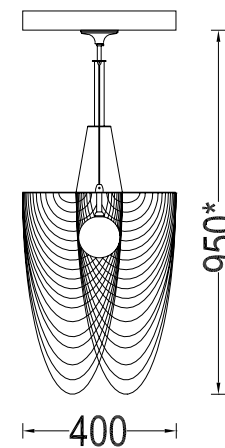
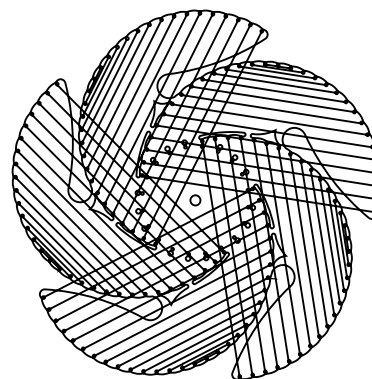
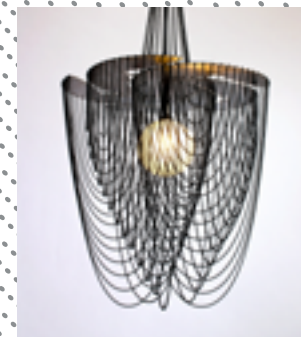

MODEL

SHADE SIZE

TOTAL HEIGHT

FRANGIPANI - 400

400W X 700H MM

950MM



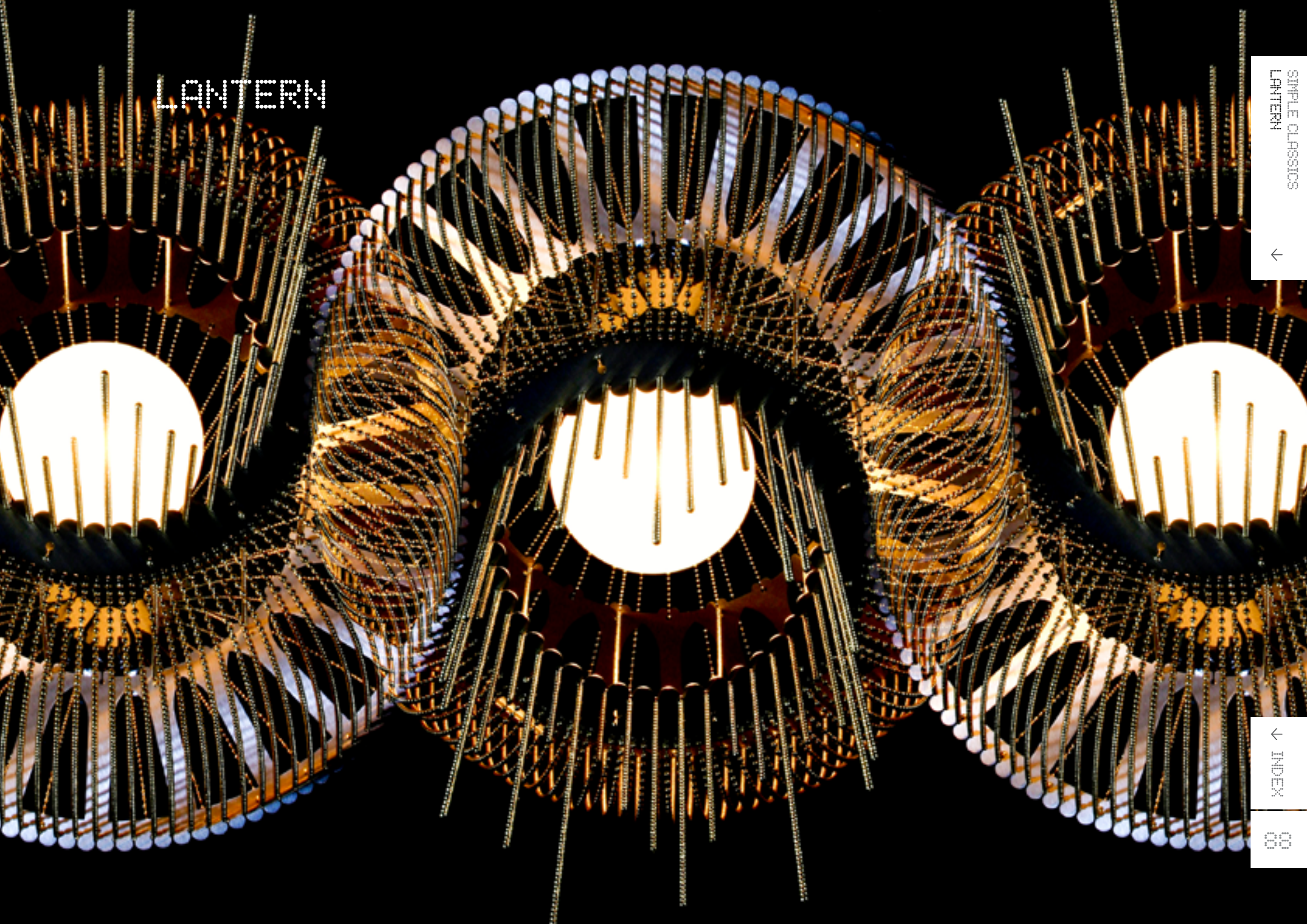

LANTERN



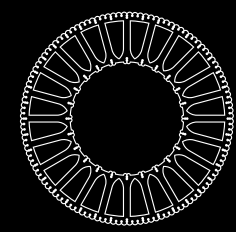

LANTERN

DESCRIPTION
A 400MM WIDE MINI-CHANDELIER PENDANT LANTERN REMINISCENT OF A CHINESE LANTERN. NOW ALSO AVAILABLE AS A WALL LANTERN AND WALL SCNCE.



PENDANT

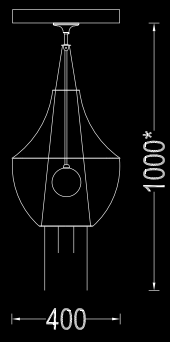

WALL LANTERN

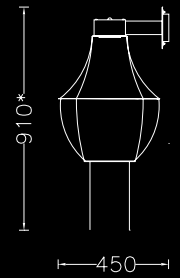

WALL SCNCE

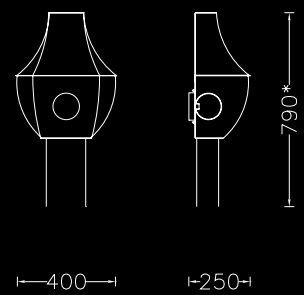

MODEL	SHADE SIZE	TOTAL HEIGHT	
LANTERN - 400	400W X 750H MM	1000MM	
LANTERN - 400 - WALL SCNCE	400 X 250W MM	790MM	
LANTERN - 400 - WALL LANTERN	400 X 450W MM	910MM	

SIMPLE LAMPS

PENDANTS, STANDING, TABLE
& WALL SCONCES



SIMPLE LAMPS

FENDANTS, STANDING, TABLE AND WALL SCONCES

To any artist, worthy of the name, all in nature is beautiful, because his eyes, fearlessly accepting all exterior truth, read there, as in an open book, all the inner truth. Auguste Rodin

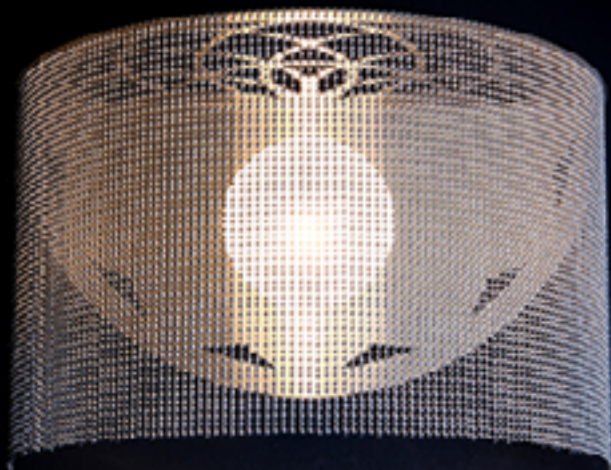

CIRCULAR
CROPPED



WALL LANTERN

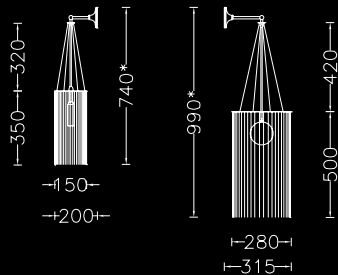

WALL SCONCE

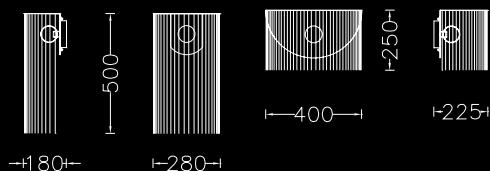

STANDING

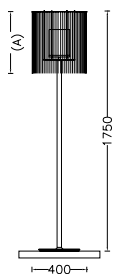

PENDANT

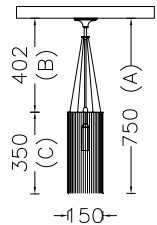

TABLE

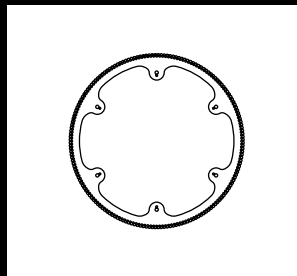
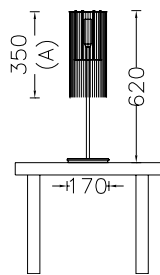

CIRCULAR CROPPED

DESCRIPTION

A FAMILY OF SIMPLE CLASSIC CIRCULAR CROPPED DRUM-SHAPED PENDANTS, TABLE LAMPS AND STANDING LAMPS. ILLUMINATED BY A PYREX GLASS DIFFUSER CONTAINING A G9-HALOGEN LAMP. AVAILABLE IN THREE DIAMETER SIZES: 150MM, 280MM AND 400MM.

MODEL	SHADE SIZE	TOTAL HEIGHT	
CIRCULAR CROPPED 150 PENDANT LAMP	150W X 350-520H MM	750MM	
CIRCULAR CROPPED 280 PENDANT LAMP	280W X 500-700H MM	1000MM	
CIRCULAR CROPPED 400 PENDANT LAMP	400W X 450-820H MM	900-1250MM	
CIRCULAR CROPPED 150 TABLE LAMP	150W X 350-520H MM	620MM	
CIRCULAR CROPPED 280 TABLE LAMP	280W X 500-700H MM	750MM	
CIRCULAR CROPPED 400 TABLE LAMP	400W X 450-700H MM	750MM	
CIRCULAR CROPPED 150 STANDING LAMP	150W X 350-520H MM	1500MM	
CIRCULAR CROPPED 280 STANDING LAMP	280W X 500-700H MM	1750MM	
CIRCULAR CROPPED 400 STANDING LAMP	400W X 450-700H MM	1750MM	
CIRCULAR CROPPED 280 WALL SCONCE	280 X 180W MM	500-700MM	
CIRCULAR CROPPED 400 WALL SCONCE	400 X 225W MM	200-450MM	
CIRCULAR CROPPED 150 WALL LANTERN	150X200W X 350-520MM	740MM	
CIRCULAR CROPPED 280 WALL LANTERN	280X315W X 500-700MM	990MM	



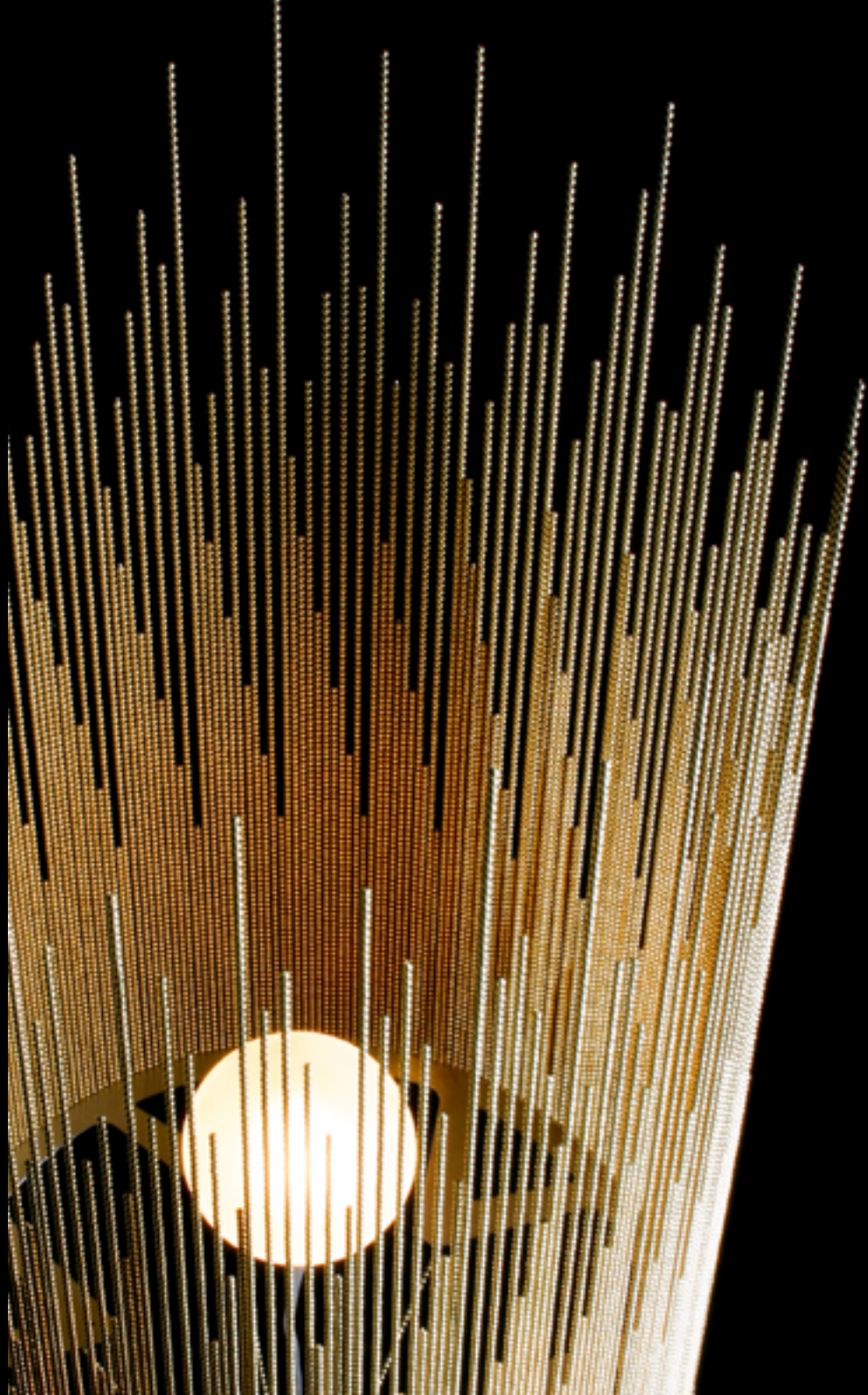

CIRCULAR WILLOW



CIRCULAR WILLOW

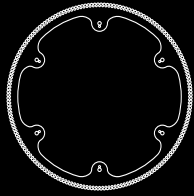

WALL SCONCE

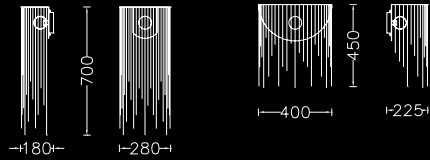

WALL LANTERN

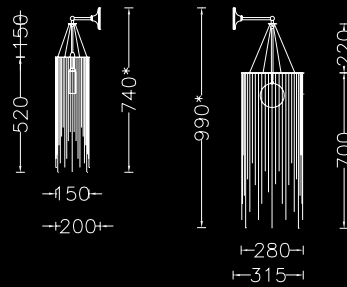

STANDING

PENDANT

TABLE

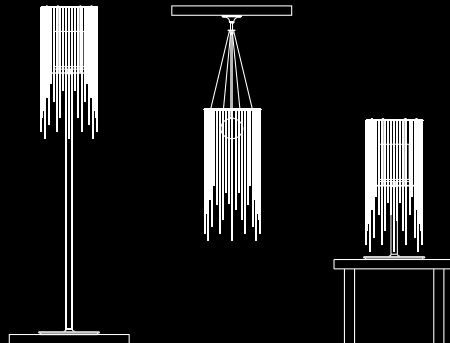

DESCRIPTION

A FAMILY OF SIMPLE CLASSIC CIRCULAR WILLOW PENDANTS, TABLE LAMPS AND STANDING LAMPS, WITH WILLOWLAMP'S DISTINCTIVE FEATHERED EDGE DETAIL WHICH WE CALL 'WILLOW'. ILLUMINATED BY A PYREX GLASS DIFFUSER CONTAINING A G9-HALOGEN LAMP. AVAILABLE IN THREE DIAMETER SIZES: 150MM, 280MM AND 400MM.

MODEL	SHADE SIZE	TOTAL HEIGHT	
CIRCULAR WILLOW 150 PENDANT LAMP	150W X 350-520H MM	750MM	
CIRCULAR WILLOW 280 PENDANT LAMP	280W X 500-700H MM	1000MM	
CIRCULAR WILLOW 400 PENDANT LAMP	400W X 450-820H MM	900-1250MM	
CIRCULAR WILLOW 150 TABLE LAMP	150W X 350-520H MM	620MM	
CIRCULAR WILLOW 280 TABLE LAMP	280W X 500-700H MM	750MM	
CIRCULAR WILLOW 400 TABLE LAMP	400W X 450-700H MM	750MM	
CIRCULAR WILLOW 150 STANDING LAMP	150W X 350-520H MM	1500MM	
CIRCULAR WILLOW 280 STANDING LAMP	280W X 500-700H MM	1750MM	
CIRCULAR WILLOW 400 STANDING LAMP	400W X 450-700H MM	1750MM	
CIRCULAR WILLOW - WALL SCONCE - 280	280 X 180W MM	500-700MM	
CIRCULAR WILLOW - WALL SCONCE - 400	400 X 225W MM	200-450MM	
CIRCULAR WILLOW - WALL LANTERN - 150	150 X 200W X 350-520MM	740MM	
CIRCULAR WILLOW - WALL LANTERN - 280	280 X 315W X 500-700MM	990MM	





CIRCULAR POD



CIRCULAR POD

WALL SCONCE

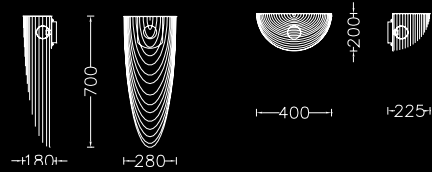

WALL LANTERN

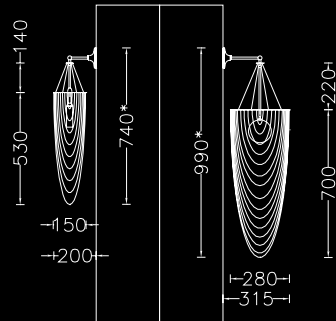

STANDING

PENDANT

TABLE

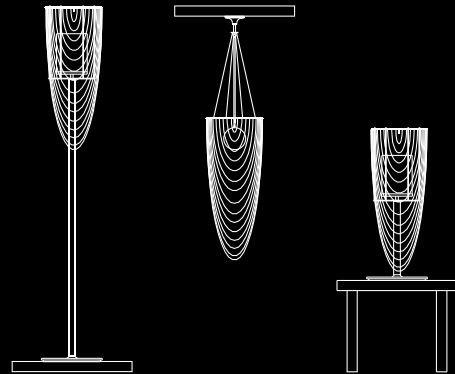

DESCRIPTION

A FAMILY OF SIMPLE CLASSIC CIRCULAR POD-SHAPED PENDANTS, TABLE LAMPS AND STANDING LAMPS. ILLUMINATED BY A PYREX GLASS DIFFUSER CONTAINING A G9-HALOGEN LAMP. AVAILABLE IN THREE DIAMETER SIZES: 150MM, 280MM AND 400MM.

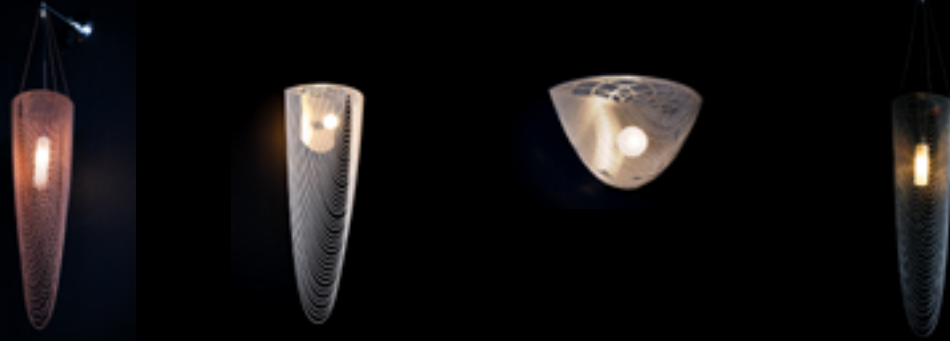

MODEL	SHADE SIZE	TOTAL HEIGHT	
CIRCULAR POD 150 PENDANT LAMP	150W X 350-520H MM	750MM	
CIRCULAR POD 280 PENDANT LAMP	280W X 500-700H MM	1000MM	
CIRCULAR POD 400 PENDANT LAMP	400W X 450-820H MM	900-1250MM	
CIRCULAR POD 150 TABLE LAMP	150W X 350-520H MM	620MM	
CIRCULAR POD 150 STANDING LAMP	150W X 350-520H MM	1500MM	
CIRCULAR POD 280 WALL SCONCE	280 X 180W MM	500-700MM	
CIRCULAR POD 400 WALL SCONCE	400 X 225W MM	200-450MM	
CIRCULAR POD 150 WALL LANTERN	150 X 200W X 350-520MM	740MM	
CIRCULAR POD 280 WALL LANTERN	280 X 315W X 500-700MM	990MM	



SCALLOPED CROPPED



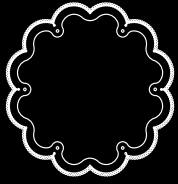

WALL SCONCE

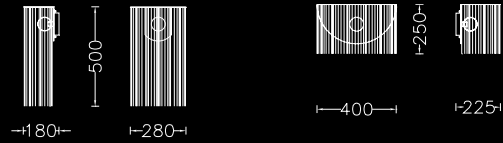

WALL LANTERN

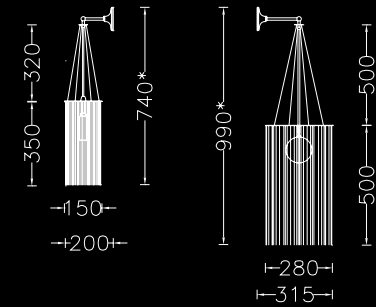

STANDING

PENDANT

TABLE

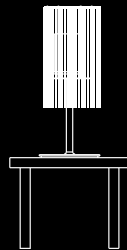
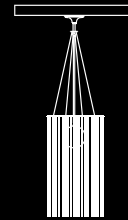
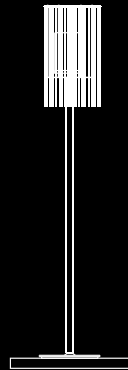

SCALLOPED CROPPED

DESCRIPTION

A FAMILY OF SIMPLE CLASSIC SCALLOPED CROPPED, DRUM-SHAPED PENDANTS, TABLE LAMPS AND STANDING LAMPS. ILLUMINATED BY A PYREX GLASS DIFFUSER CONTAINING A G9-HALOGEN LAMP. AVAILABLE IN THREE DIAMETER SIZES: 150MM, 280MM AND 400MM.



MODEL	SHADE SIZE	TOTAL HEIGHT	
SCALLOPED CROPPED 150 PENDANT LAMP	150W X 350-520H MM	750MM	
SCALLOPED CROPPED 280 PENDANT LAMP	280W X 500-700H MM	1000MM	
SCALLOPED CROPPED 400 PENDANT LAMP	400W X 450-820H MM	900-1250MM	
SCALLOPED CROPPED 150 TABLE LAMP	150W X 350-520H MM	620MM	
SCALLOPED CROPPED 280 TABLE LAMP	280W X 500-700H MM	750MM	
SCALLOPED CROPPED 400 TABLE LAMP	400W X 450-700H MM	750MM	
SCALLOPED CROPPED 150 STANDING LAMP	150W X 350-520H MM	1500MM	
SCALLOPED CROPPED 280 STANDING LAMP	280W X 500-700H MM	1750MM	
SCALLOPED CROPPED 400 STANDING LAMP	400W X 450-700H MM	1750MM	
SCALLOPED CROPPED 280 WALL SCONCE	280 X 180W MM	500-700MM	
SCALLOPED CROPPED 400 WALL SCONCE	400 X 225W MM	200-450MM	
SCALLOPED CROPPED 150 WALL LANTERN	150 X 200W X 350-520MM	740MM	
SCALLOPED CROPPED 280 WALL LANTERN	280 X 315W X 500-700MM	990MM	



SCALLOPED
WILLOW



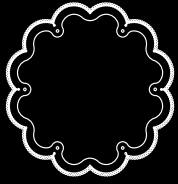

WALL SCNCE

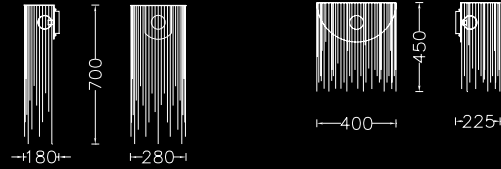

WALL LANTERN

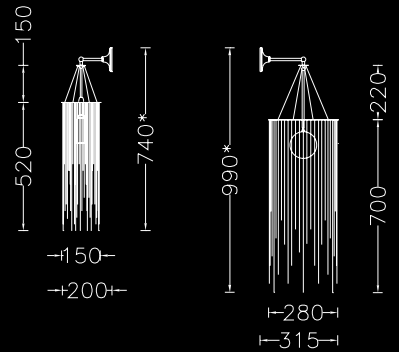

STANDING

PENDANT

TABLE

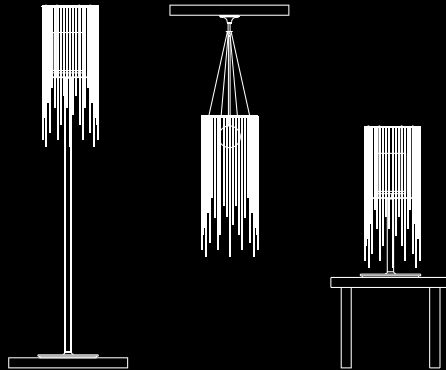

SCALLOPED WILLOW

DESCRIPTION

A FAMILY OF SIMPLE CLASSIC SCALLOPED WILLOW PENDANTS, TABLE LAMPS AND STANDING LAMPS, WITH WILLOWLAMP'S DISTINCTIVE FEATHERED EDGE DETAIL, WHICH WE CALL 'WILLOW'. ILLUMINATED BY A PYREX GLASS DIFFUSER CONTAINING A G9-HALOGEN LAMP. AVAILABLE IN THREE DIAMETER SIZES: 150MM, 280MM AND 400MM.

MODEL	SHADE SIZE	TOTAL HEIGHT	
SCALLOPED WILLOW 150 PENDANT LAMP	150W X 350-520H MM	750MM	
SCALLOPED WILLOW 280 PENDANT LAMP	280W X 500-700H MM	1000MM	
SCALLOPED WILLOW 400 PENDANT LAMP	400W X 450-820H MM	900-1250MM	
SCALLOPED WILLOW 150 TABLE LAMP	150W X 350-520H MM	620MM	
SCALLOPED WILLOW 280 TABLE LAMP	280W X 500-700H MM	750MM	
SCALLOPED WILLOW 400 TABLE LAMP	400W X 450-700H MM	750MM	
SCALLOPED WILLOW 150 STANDING LAMP	150W X 350-520H MM	1500MM	
SCALLOPED WILLOW 280 STANDING LAMP	280W X 500-700H MM	1750MM	
SCALLOPED WILLOW 400 STANDING LAMP	400W X 450-700H MM	1750MM	
SCALLOPED WILLOW 280 WALL SCNCE	280 X 180W MM	500-700MM	
SCALLOPED WILLOW 400 WALL SCNCE	400 X 225W MM	200-450MM	
SCALLOPED WILLOW 150 WALL LANTERN	150 X 200W X 350-520MM	740MM	
SCALLOPED WILLOW 280 WALL LANTERN	280 X 315W X 500-700MM	990MM	





SCALLOPED LOOPED



SCALLOPED LOOPED

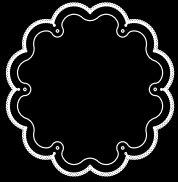

WALL SCONCE

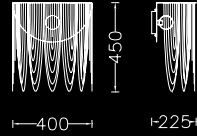
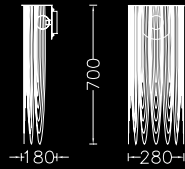

WALL LANTERN

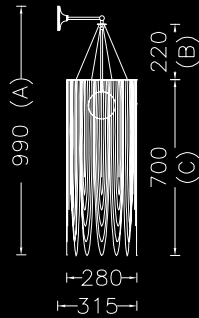
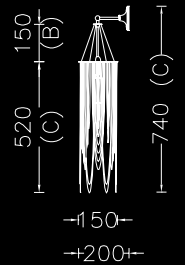

STANDING

PENDANT

TABLE

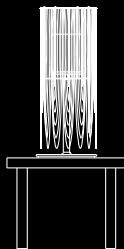
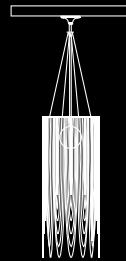
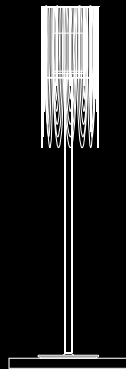

DESCRIPTION

A FAMILY OF SIMPLE CLASSIC SCALLOPED LOOPED-SHAPED PENDANTS, TABLE LAMPS AND STANDING LAMPS. ILLUMINATED BY A PYREX GLASS DIFFUSER CONTAINING A G9-HALOGEN LAMP. AVAILABLE IN THREE DIAMETER SIZES: 150MM, 280MM AND 400MM.

MODEL	SHADE SIZE	TOTAL HEIGHT	
SCALLOPED LOOPED 150 PENDANT LAMP	150W X 350-520H MM	750MM	
SCALLOPED LOOPED 280 PENDANT LAMP	280W X 500-700H MM	1000MM	
SCALLOPED LOOPED 400 PENDANT LAMP	400W X 450-820H MM	900-1250MM	
SCALLOPED LOOPED 150 TABLE LAMP	150W X 350-520H MM	620MM	
SCALLOPED LOOPED 280 TABLE LAMP	280W X 500-700H MM	750MM	
SCALLOPED LOOPED 400 TABLE LAMP	400W X 450-700H MM	750MM	
SCALLOPED LOOPED 150 STANDING LAMP	150W X 350-520H MM	1500MM	
SCALLOPED LOOPED 280 STANDING LAMP	280W X 500-700H MM	1750MM	
SCALLOPED LOOPED 400 STANDING LAMP	400W X 450-700H MM	1750MM	
SCALLOPED LOOPED 280 WALL SCONCE	280 X 180W MM	500-700MM	
SCALLOPED LOOPED 400 WALL SCONCE	400 X 225W MM	200-450MM	
SCALLOPED LOOPED 150 WALL LANTERN	150 X 200W X 350-520MM	740MM	
SCALLOPED LOOPED 280 WALL LANTERN	280 X 315W X 500-700MM	990MM	





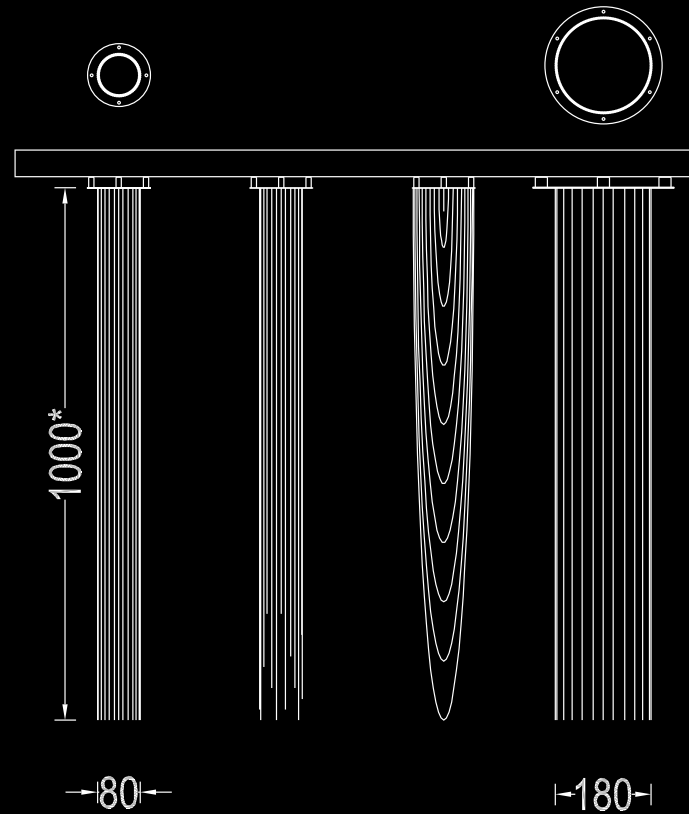

DOWNLIGHTER
'RETRO-FITS'

DOWNLIGHTER 'RETRO-FITS'



DESCRIPTION

A FAMILY OF SIMPLE CLASSIC LAMPSHADES, SOLD AS 'SHADE-ONLY' TO BE RETROFITTED AROUND HALOGEN CEILING DOWNLIGHTS. THE LENGTH AND EDGE TYPE MAY BE SPECIFIED AND TAILORED TO SPECIFIC CUSTOMER REQUIREMENTS. PRICED PER METER. AVAILABLE IN THREE STYLES: CIRCULAR CROPPED, CIRCULAR WILLOW AND CIRCULAR POD, AND IN TWO DIAMETER SIZES: 80MM OR 180MM.

MODEL	SHADE SIZE	TOTAL HEIGHT	
DOWNLIGHTER RETROFIT 80	80W X 1000H MM	PRICED PER METER	
DOWNLIGHTER RETROFIT 180	180W X 1000H MM	PRICED PER METER	

CHOOSE THE PERFECT WILLOWLAMP TO SUIT YOUR LIFESTYLE

Commission us to **custom design** your own willowlamp to suit your individual taste and lifestyle or choose from our **standard collection**.

Our standard collection is divided into four main groupings: Lamps, Pendants, Chandeliers and Art Forms.

Each willowlamp is available in different finishes, and we can tailor the height and length of the pendants and chandeliers to suit your space. See our colour bar or willowlamp.com for more detail.

'Flat-Pack' Benefits: Every willowlamp is flat-packed and shipped in special, environmentally-friendly packing crates. Flat-pack shipping significantly reduces costs. It is an experience in itself to see the beautiful piece unfolding out of its packaging

Support, Service and Logistics: We aim to deliver customer service that is as outstanding as our designs. The willowlamp mark means not only attention to detail, but personal attention, too.

Standard Finishes & Colours:

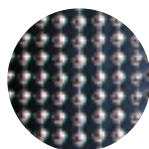

SILVER (CHROME)

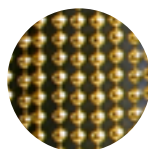

BRASS

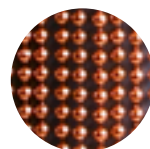

COPPER

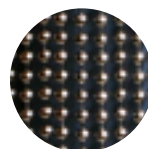

SMOKE

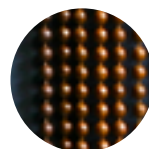

RUST

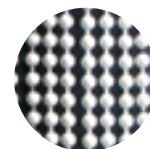

WHITE

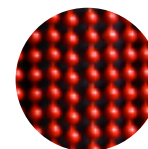

RED

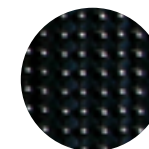

BLACK

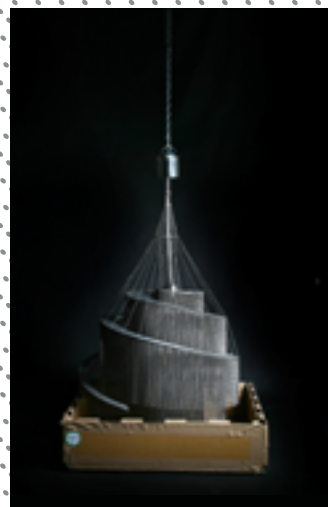
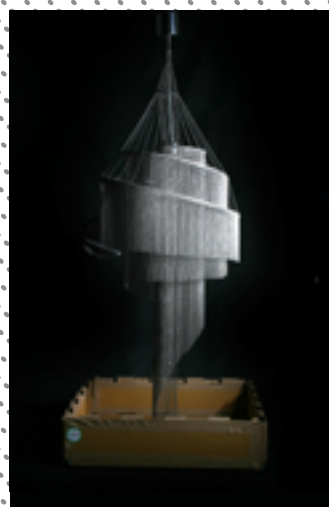
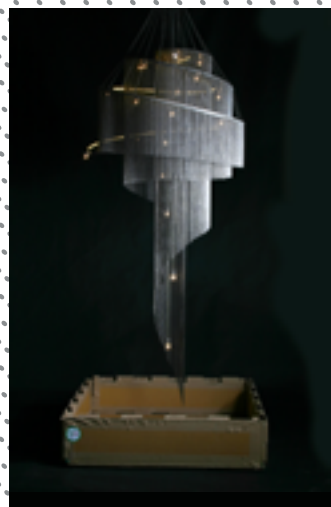

OUR AGENTS AND SALES PARTNERS

We are represented around the world by a network of willowlamp agents and trading partners. Contact the agent in your region or our head office listed, for more information about willowlamp. We are always seeking new agents and trading partners to help us expand into new markets. This is a part of our sustainable business growth strategy. If you have an in-depth understanding of your market and have the skills and experience to help expand our customer base, please contact us to discuss how we can work together.



UNITED KINGDOM

Cameron Peters Fine Lighting Ltd
Home Farm, Ardington, Wantage, OX12 8PD, England
tel +4 4 (0)1235 835000 | fax +44(0)1235 835005
contact@cameronpeters.co.uk | www.cameronpeters.co.uk

AUSTRALIA

Emily Ziz Style Studio
38B Gurner Street, Paddington, NSW, 2021
tel 02 9380 4180 | fax 02 8587 0009
info@emilyziz.com | www.emilyziz.com

GERMANY - AUSTRIA - SWITZERLAND

african avantgarde
Cathrin Hennicke
Sebastianstr. 38, 53115 Bonn
tel: +49 228 240 22974
ch@african-avantgarde.de | www.african-avantgarde.de

SOUTH AFRICA

willowlamp Head Office Factory and Sales:
6 Spencer Square, 6 Spencer Street, Salt River, Cape Town
tel +27 (0)21 447 8529 | fax +27 (0)86 512 9930
info@willowlamp.com | www.willowlamp.com

Johannesburg Showroom:
Glo Lighting And Living
27 6th St, Parkhurst, 2193, Johannesburg
tel +27 (0)11 447 3667 | fax +27 86 574 2214

Durban Showroom:
Light And living
Unit 5, Beacon Rock,
21 Lighthouse Rd, Umhlanga 4320
+27 (0)31 561 1408 or +27 (0)82 856 3404

Agent details are correct at the time of going to print and may change.
Visit willowlamp.com for an updated contact list of agents in your area.

THE TEAM THAT BRINGS WILLOWLAMP TO LIFE

The willowlamp notch was patented in 2007. Since then, we have built a reliable team of trading partners, specialist industrial suppliers and in-house professionals whose work and skill are vital to willowlamp's success.

Our industrial partners deliver precision laser-cut, machined and finished components. This enables our factory team to hand-assemble each willowlamp with meticulous attention to detail in our immaculate, highly organised and creative space. We also have a broad network of internationally connected, active marketing and sales specialists whose role is to embed willowlamp firmly on the global design stage.

Our professional in-house support team ensures that willowlamp is shipped with care to our clients all over the world.



AWARDS AND COLLABORATIONS

AWARDS:

- 2019: LIT Awards: 'Designer and Custom Lighting' for the Southern Flame - winner
- 2019: LIT Awards: 'Chandeliers' for Giant Fuschia - winner
- 2019: D'Ark Award 'KIT for the Halo 3rd place
- 2019: D'Ark Award 'Bespoke Installation' for Giant Fuschia 3rd place
- 2017: Guild Foundation Award 'Object that moves' category
- 2016: D'Ark Award 'Hospitality' 2nd place
- 2014: 100% Design Johannesburg best lighting award
- 2009: SABS design excellence award
- 2008: Elle Décor overall designer of the year award
- 2007: Elle Décor lighting designer of the year
- 2006: Elle Décor lighting designer of the year

RETROSPECTIVE EXHIBITIONS:

- 2019: 15 year Retrospective Exhibition – Willowlamp factory, Cape Town
- 2011: Arts on Main collaboration, Johannesburg
- 2010: 'Global Africa Project' Museum of Arts & Design, New York **

We have had the privilege of participating in some of the leading design exhibitions that celebrate outstanding creativity in product design. We have also won globally prestigious design awards.

INVITATIONS AND PARTICIPATION:

- 2019: EuroLuce, Salon de Mobile, Milan Italy – willowlamp solo exhibition
- 2018: Design Days Dubai, willowlamp in collaboration with 'Brandkonnnect' & 'Indigenus'
- 2018: Launch of 2018 collection, Youngblood Gallery Cape Town
- 2018: Salon of Art & Design – Invited by Southern Guild* showcased 'Southern Flame'
- 2018: 'Extra-Ordinary' – Invited by Southern Guild* showcased 'Southern Flame'
- 2017: 100% Design Johannesburg – willowlamp and Meyer Von Weilligh
- 2015: 100% Design Johannesburg – willowlamp and Meyer Von Weilligh
- 2014: Light Junction, London
- 2014: 100% Design London – invited by Cape Craft and Design Institute
- 2014: 100% Design Johannesburg – willowlamp and John Vogel
- 2013: Art Basel – invited by Southern Guild*
- 2012: Design days, Dubai – invited by Southern Guild*
- 2011: The Johannesburg Art Fair, Johannesburg – invited by Southern Guild*
- 2011: Invited to exhibit in the Salon Privé at Design Indaba, Cape Town
- 2010: ICFF, New York - invited by the Amaridian Gallery
- 2009: The Johannesburg Art Fair, Johannesburg – invited by Southern Guild*
- 2009: Ambiente, Frankfurt – invited by the South African Dept. of Trade and Industry
- 2008: Maison and Objet, Paris – invited by the Rosita Gallery
- 2007: ICFF, New York – invited by the Amaridian Gallery



* Southern Guild is an exhibition of South African artists, designers and crafts people that travels to art and design shows across the globe.

** The 'Global Africa Project' was a travelling exhibition that started its life at the Museum of Arts and Design in New York. This significant exhibition showcased design originating from Africa with the aim of correcting stereotypes about the level of art, craft and design from the continent.



