



SURFACE COLLECTION / 2020
CEMENT TILES & ZELLIGES





BRAND STORY /

'The aim of art is not to represent the outward appearance of things, but their inward significance.' - Aristotle

Opia is a supplier of handmade, concrete and zellige tiles in South Africa. Our products are designed by internationally renowned creators and handmade by artisans in Morocco.

At Opia, we consider our homes to be the beginning of our stories; we thrive to offer interiors rich of our customer's identity; sustainable and respectful of the people and the resources involved.

We genuinely believe that products are not only defined by their quality but also by the feelings they evoke and the unique print they bring to an interior. In this simple approach, we work with prominent companies who specialise in hand-made tiles. With our suppliers, we aim to offer a product that goes back to essential values, far from fast consumption and a limited life-span. To each interior, we bring an ancestral tradition where durability, timelessness and elegance are both proven and shared across cultures.

We consider that luxury can only be achieved when people, materials and processes are respected and celebrated. Through Opia, we aim to continue the exploration of the cultural and permanent redefinition of this heritage.





BEHIND THE BRAND /

Born and raised in Belgium, the two founders always went back to Morocco, where they enjoyed its old treasures and flourishing artisanal culture. From their different backgrounds, they kept the best and created a space where tradition and modernity are continuously reinvented. The common language of multiculturalism in South Africa make them feel at home and naturally lead them to share their passion for design and interior architecture.

GHIZLAINE MENECHI / FOUNDER

In a previous life, Ghizlaine was a dedicated humanitarian worker; travelling in Africa and the Middle-East covering major human-made or natural crisis. From these experiences, she was shaped to believe that authenticity and protection of our resources are fundamental values. Discovering the world is at the centre of Ghizlaine's philosophy; without a respectful and fair sharing of principles with others, our human potential would remain unseen. Morocco, Italy, Syria, Turkey, France are a few of the outstanding countries that inspired her interior design style and the co-creation of Opia Design.

LAILA YASSINI / FOUNDER

Laila is a modern nomad with substantial experience in social economy. She worked with artisans in West and North Africa to protect their skills, encouraging and supporting local cooperatives to continue to develop. For Laila, progress can only be achieved when the human is placed at the centre of trade, respected and valued correctly. From South-East and Central Asia to Africa, her curiosity and thrive for different models and perspectives made the projects where she was involved successful and sustainable. With the same willingness to continue on this path, she has developed Opia Design's strategy to offer fair, handmade and sustainable products while her interest for timeless and elegant style allows her to direct Opia's choices.

In line with their values and backgrounds, Ghizlaine and Laila choose to partner with Popham Design and Ateliers Zelij to strengthen their vision of durability and design.



BRAND VALUES/

While focusing on trends and being at the front line of interior design redefinition, we pride ourselves on maintaining an ethical approach towards the production and supply of our products...

DESIGN

All our suppliers have in common a deep respect and understanding of the heritage and the processes of production. Following the mastering of these methods, they're re-imagined the future, let themselves be inspired by trends, culture and art to bring new perspectives to these ancestral legacies. Today, our partners are at the frontline of Design and interior architecture, offering unique creations to customers.

SUSTAINABILITY

The materials and processes used to create both our concrete tiles and zellige are environmentally friendly. Our suppliers aim to follow a manufacturing process that adds as little stress on to the environment as possible, sourcing locally, using recycled packaging, grey water wherever possible and solar-powered heating.



FAIR-TRADE

Our suppliers are engaged to guarantee a fair salary and social protection to all their employees. We consider that protecting artisans is what keeps a culture alive. Both Popham Design and Ateliers Zelij practice fair labour by providing their employees with a safe and healthy workplace in the form of paid holidays, health care benefits and an environmentally friendly production system. Opia and our suppliers are dedicated to maintaining an open, honest and respectful relationship with our customers.

QUALITY

We don't sacrifice quality. Working exclusively with companies that have developed a strong knowledge in their area. Our suppliers are capable of meeting high standards and delivery systems to allow a timely distribution all over the world. That's why more and more professional designers and consumers like to use them as a guarantee of high quality, uniquely decorative and long-lasting solutions, impossible to reproduce at an industrial level.





CONCRETE TILES/

The cement tiles have entered interiors in the 19th century and have since imposed their uniqueness across cultures.

The history of cement tiles started in France around 1850 where the outstanding durability and aesthetics of this floor covering led to rapid development all over Europe and the rest of the world. In Morocco, the close relationship with France and their shared passion for architectural design lead to unique creations around the concrete tile.

Thanks to a hydraulic-press technique that dates from 150 years ago, very little energy goes into the production of these tiles, consuming almost no power to manufacture.

Our suppliers Popham Design and Ateliers Zelij were chosen based on Opia's strict criteria of Design, Quality, Ethics and Sustainability.





POPHAM DESIGN/

Hidden in an olive grove in Marrakech, every Popham Design tile is lovingly and meticulously hand-made by skilled artisans.

The idea of designing and manufacturing concrete tiles was born in 2007 following the renovation of a 250 years-old house in the medina of Marrakech. Since then, Popham develops and produces handmade concrete tiles embellishing interiors all around the world - from San Francisco to Sydney.

Over the years, Popham has improved the process, making the tiles thinner, stronger and less permeable. The sand, commonly used as a cheaper aggregate, has been replaced by marble powder creating a solid tile, magnifying the pigments.

Popham Design takes great care in ensuring that their products contain no lead or harmful toxins. Therefore, the concrete tiles are ideally suited, safe to both residential and commercial applications and perform very well when partnered with radiant heat or moisture.

Ninety percent of the materials used to create the concrete tiles are sourced in Marrakech and air dried naturally to save energy. Reclaimed water is used in the cement mixture and wherever possible, greywater is used to run the factory.

The company is an inspiring example of rewarding employment where people and products are treated with respect. Incredibly generous and close to their team, the couple is on hand daily at the workshop to ensure the quality of their tiles and sustain this astounding workplace.

Looking at one tile and the imperfections seem unacceptable. Looking at a tiled wall or floor and we soon realise the handmade quality with subtle colour variations are what give the installation depth, movement and charm. Popham Design doesn't try to erase the hand of the artisan; they celebrate it.

Opia Design is the proud distributor of Popham Design in South Africa. For their full range visit their website: pophamdesign.com

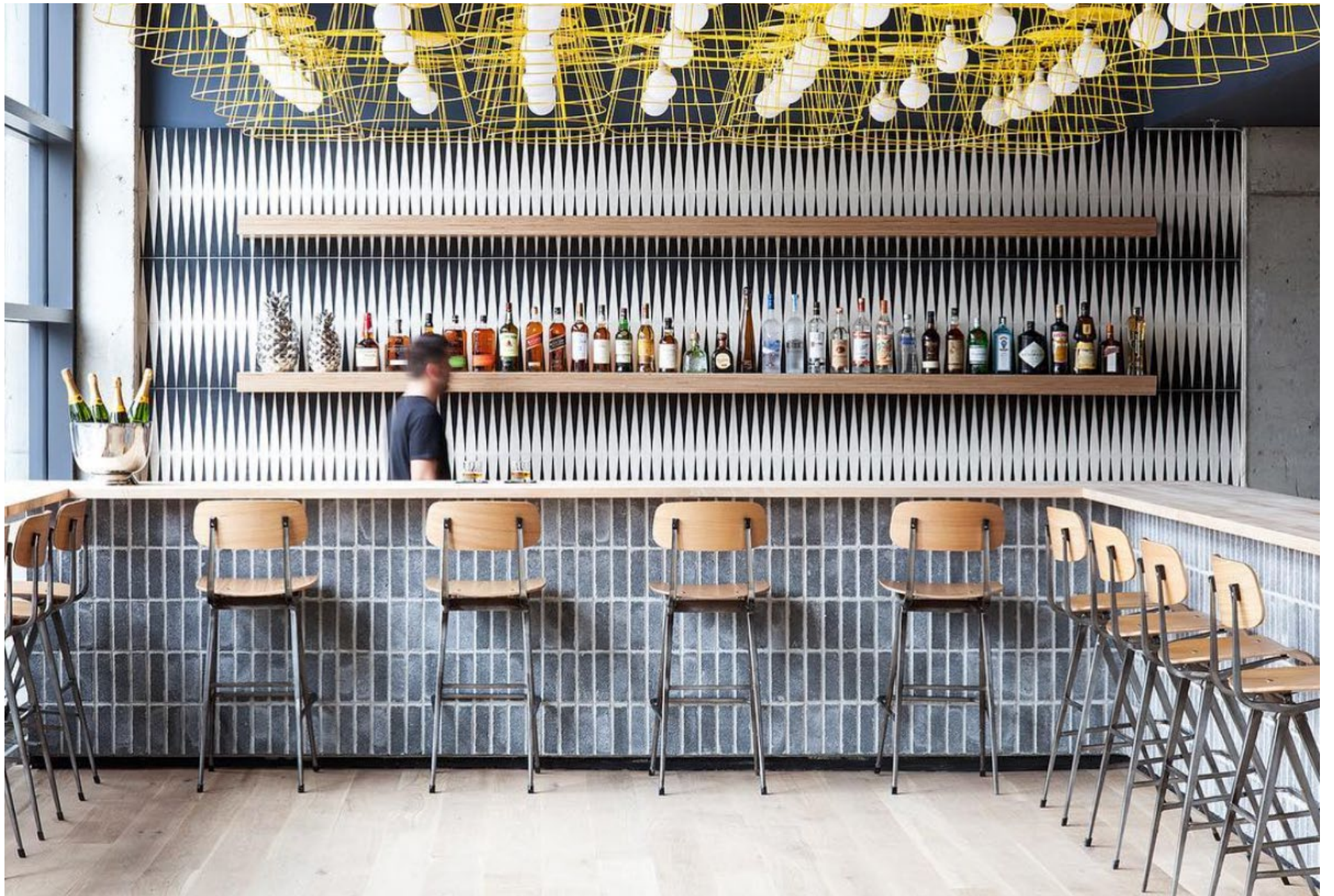

ANDO / MARINE & MILK

20 cm x 20cm x 1.2cm (thick), R800/box, excl VAT
Each box includes 18 tiles, covering an area of 0.72 sqm

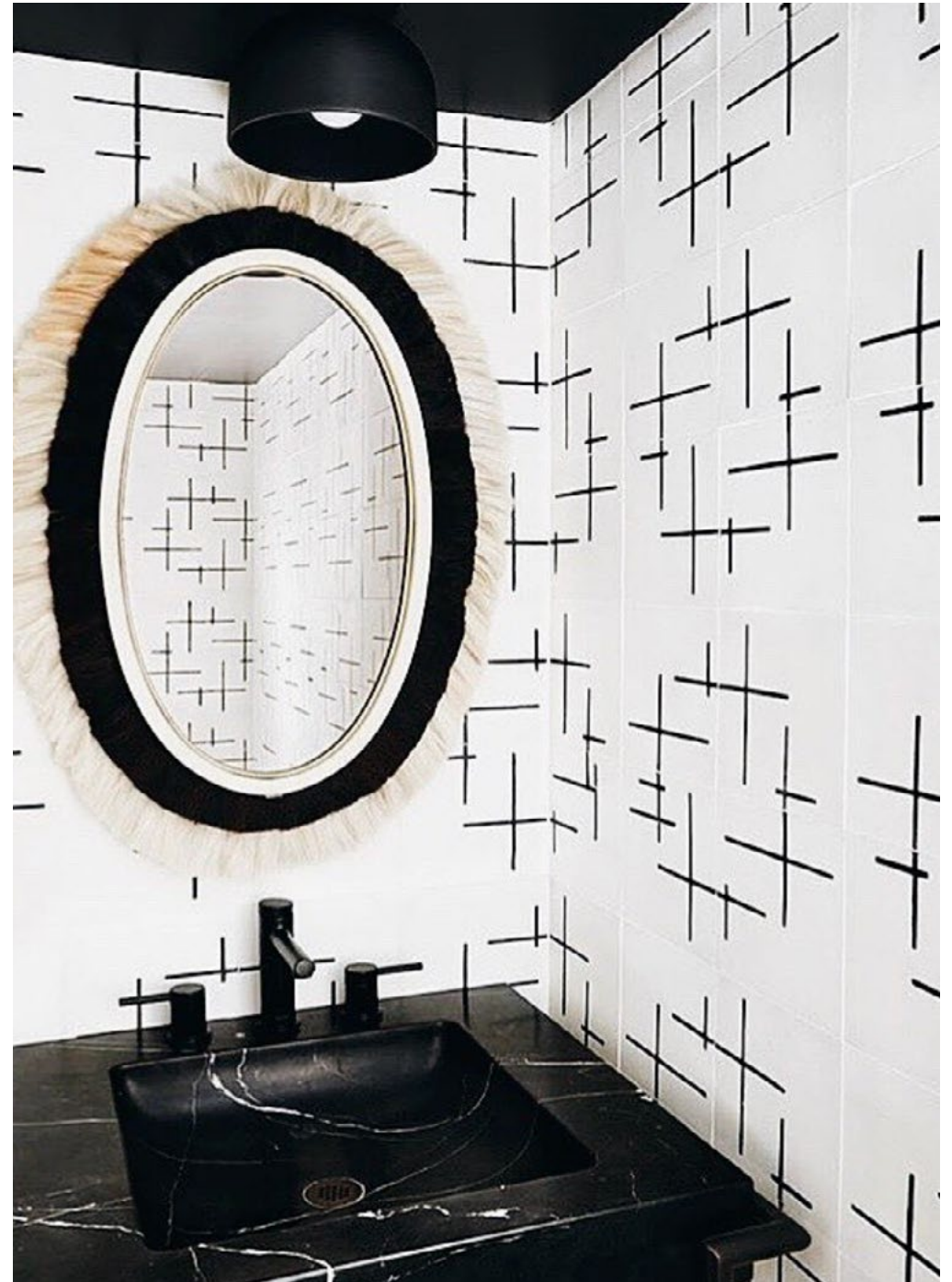
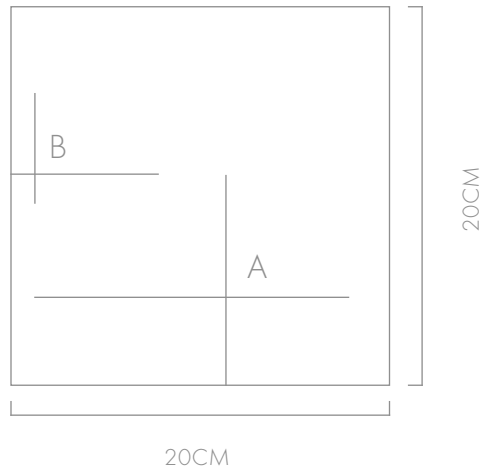
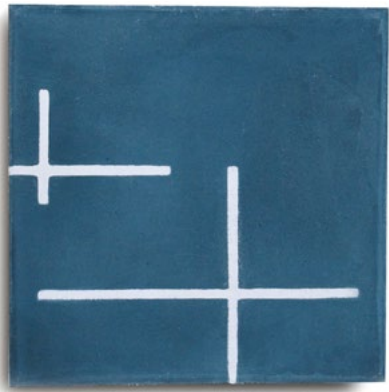

BACKGAMMON / CHARCOAL & MILK

30.5 cm x 20 cm x 1.2cm (thick), R1385/box, excl VAT
Each box includes 14 tiles, covering an area of 0.87 sqm

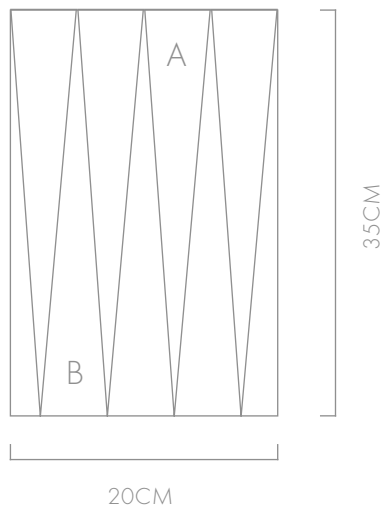

HEX ARROW / MIDNIGHT & BONE

23 cm x 20cm x 1.2cm (thick), R1050/box, excl VAT
Each box includes 18 tiles, covering an area of 0.62 sqm

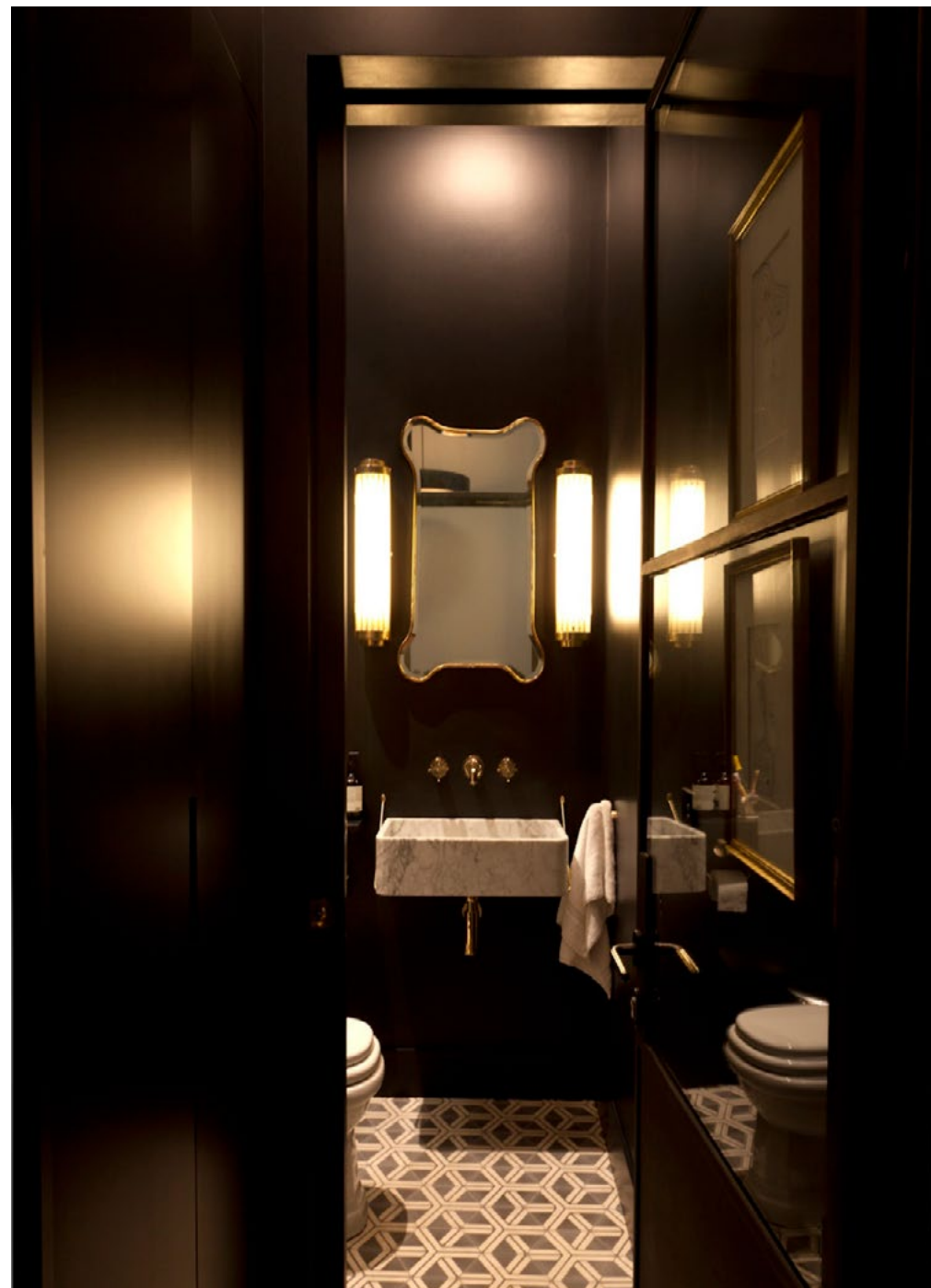
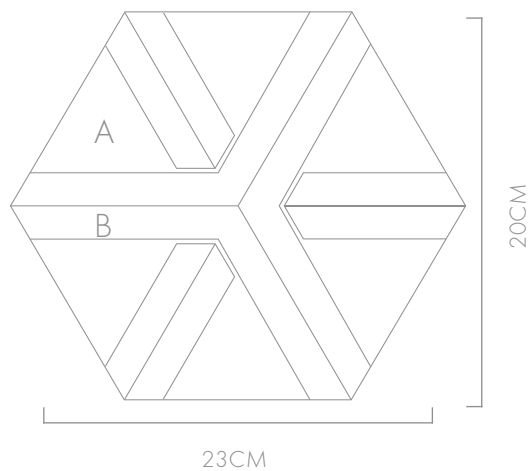

ENVELOPE / OYSTER & MILK

20 cm x 20cm x 1.2cm (thick), R1150/box, excl VAT
Each box includes 18 tiles, covering an area of 0.72 sqm

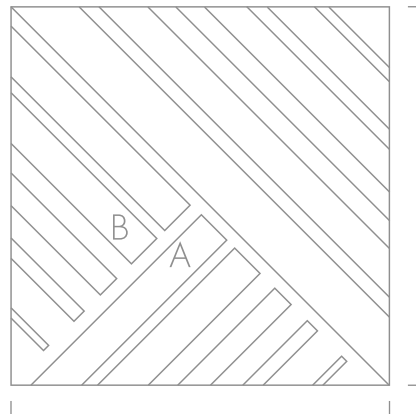

20CM

20CM



ENVELOPE / EMERALD & MILK

20 cm x 20cm x 1.2cm (thick), R1150/box, excl VAT
Each box includes 18 tiles, covering an area of 0.72 sqm

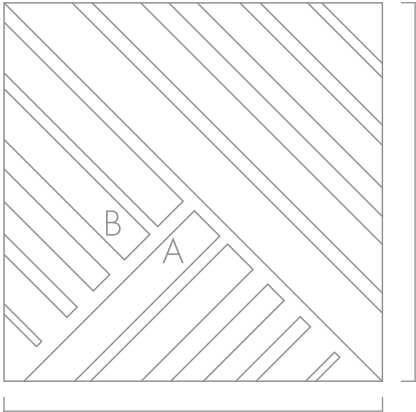

20CM

20CM



ENVELOPE / MARINE & MILK

20 cm x 20cm x 1.2cm (thick), R1150/box, excl VAT
Each box includes 18 tiles, covering an area of 0.72 sqm

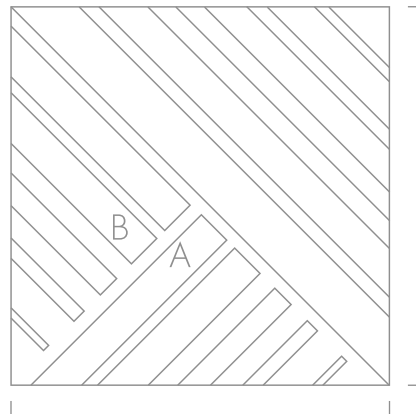

20CM

20CM

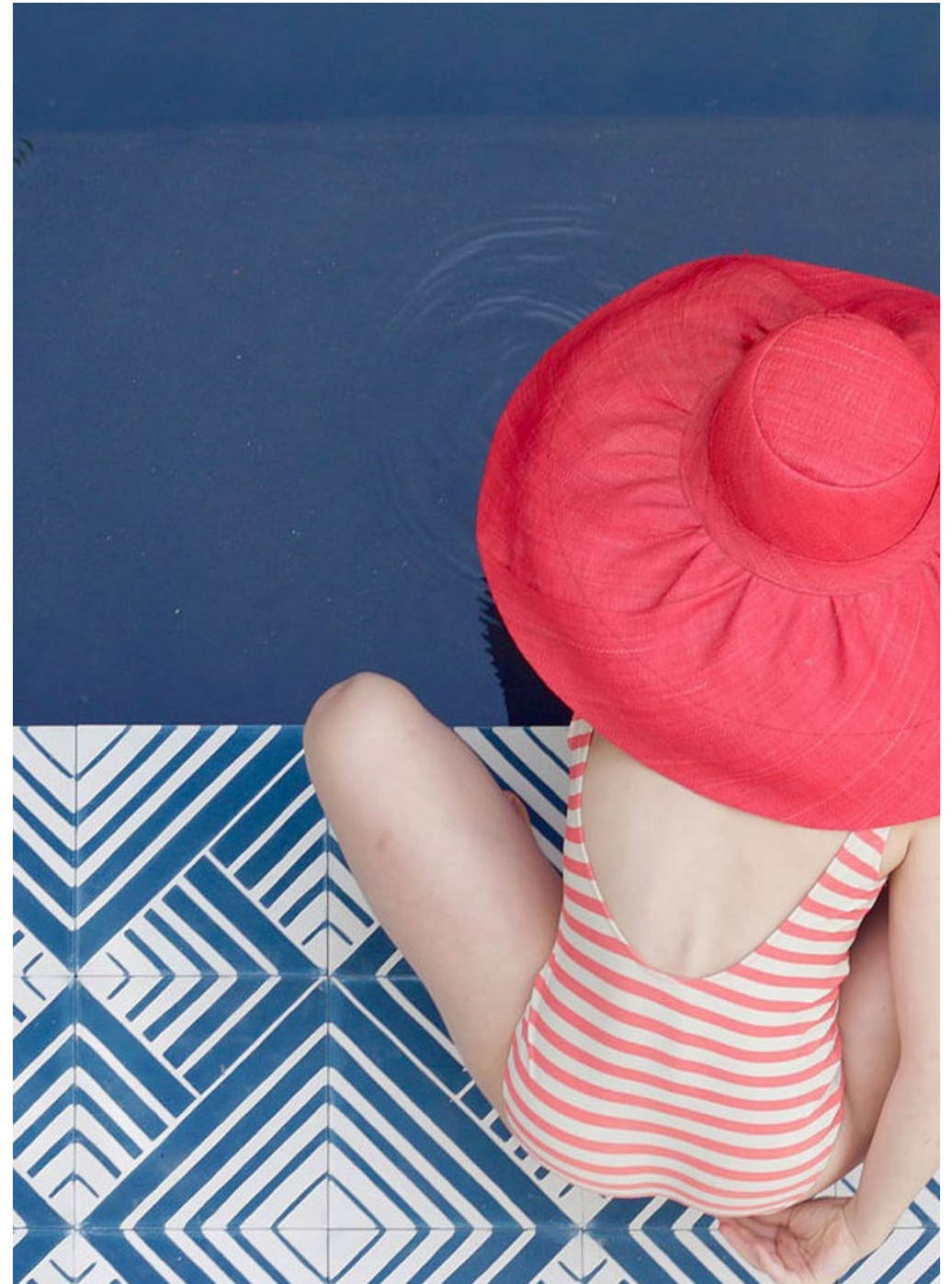

NOOR / BLACK & CHARCOAL

20 cm x 20cm x 1.2cm (thick), R800/box, excl VAT
Each box includes 18 tiles, covering an area of 0.72 sqm

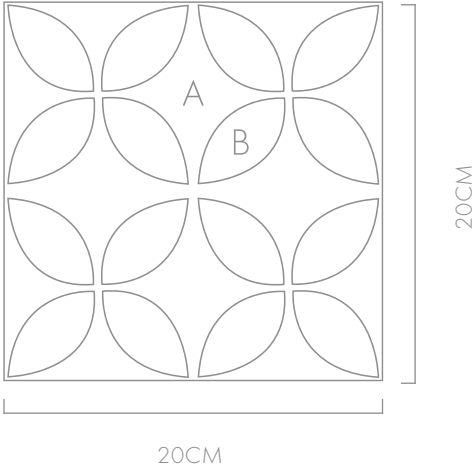
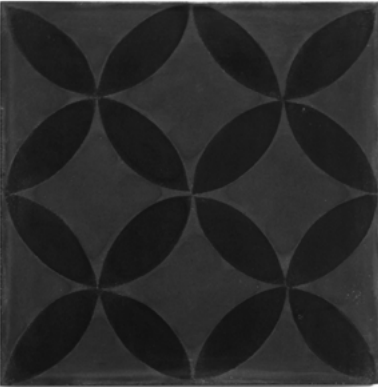

ATELIERS ZELIJ CEMENT COLLECTION HEX 4 / BLUE GREY

20 cm x 23cm x 1.2cm (thick), R1270/m2, excl VAT
Each box includes 12 tiles, covering an area of 0.42 sqm

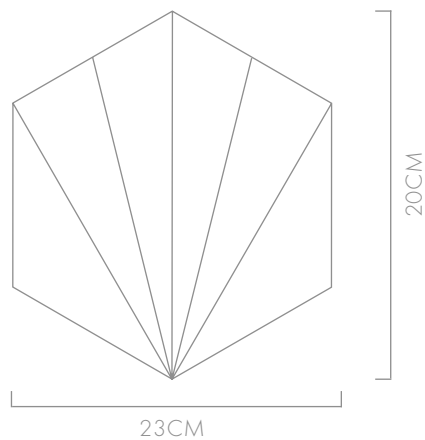
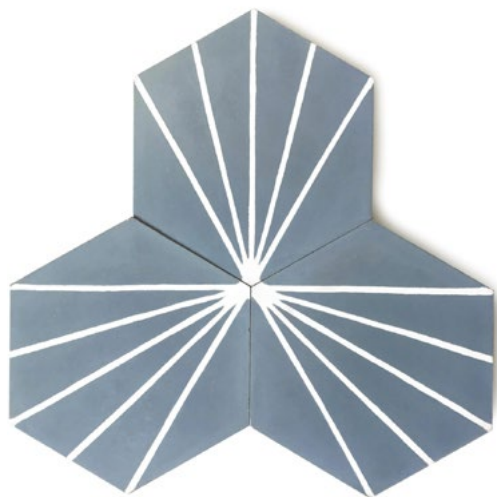

HEX 4 / BLUE

20 cm x 23cm x 1.2cm (thick), R1270/m2, excl VAT
Each box includes 12 tiles, covering an area of 0.42 sqm

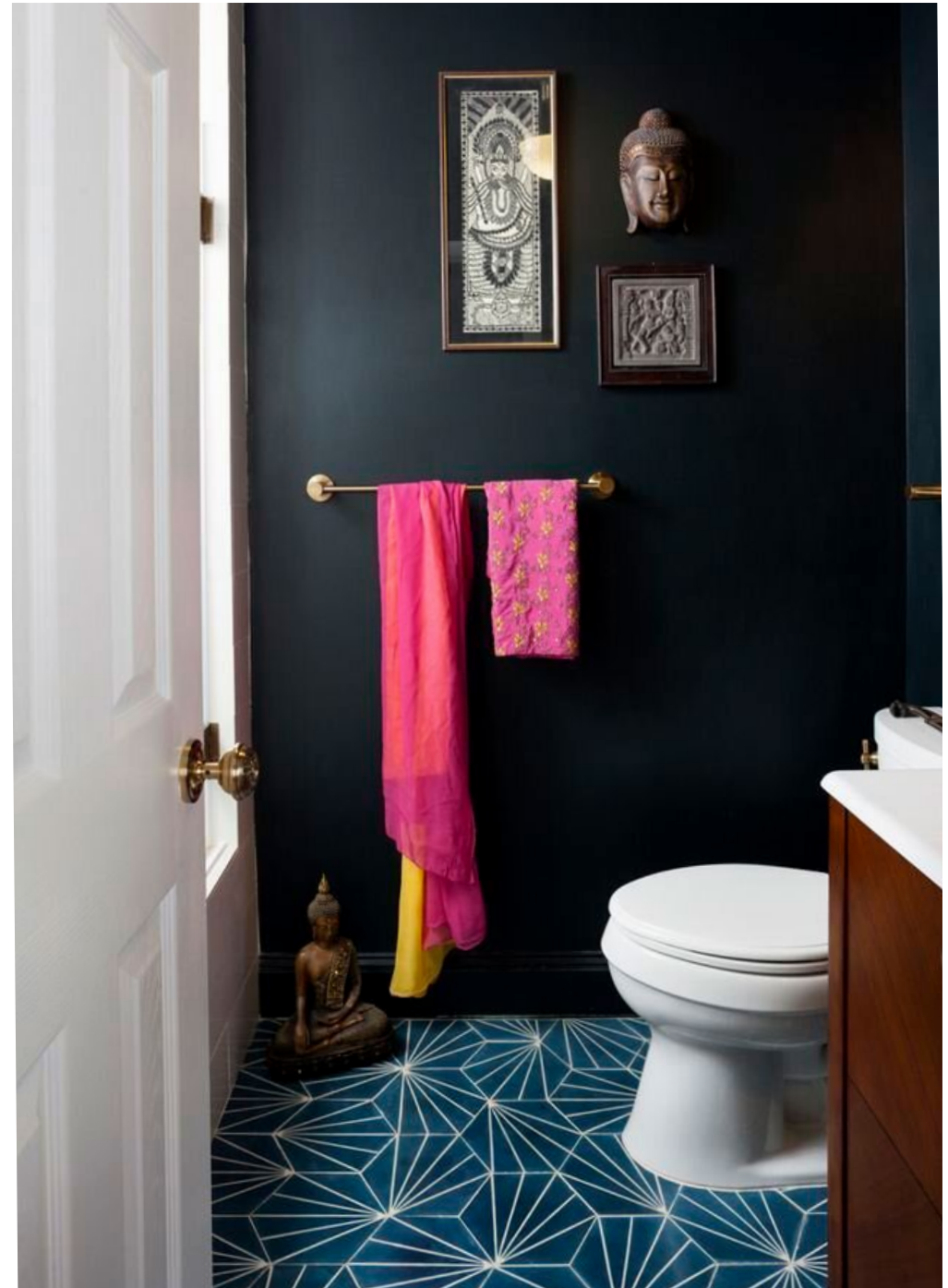
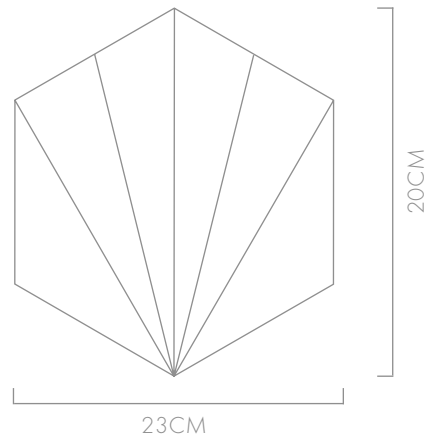
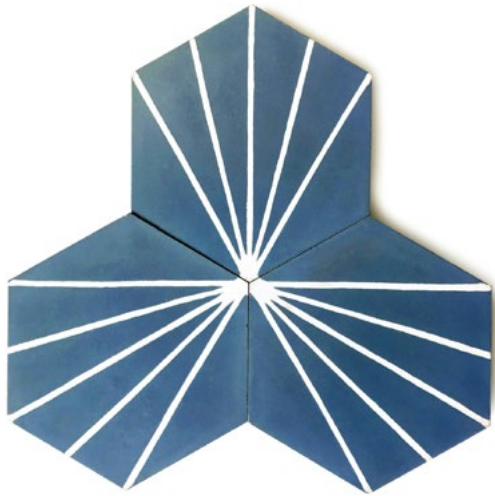

HEX 4 / GREEN

20 cm x 23cm x 1.2cm (thick), R1270/m2, excl VAT
Each box includes 12 tiles, covering an area of 0.42 sqm

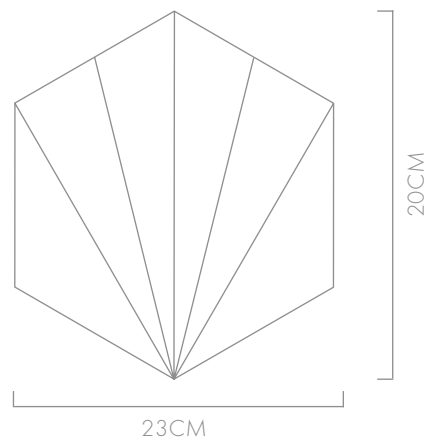

HEX 5 / MILK & SOFT GREY

23 cm x 20cm x 1.2cm (thick), R1270/m², excl VAT
Each box includes 12 tiles, covering an area of 0.48 sqm

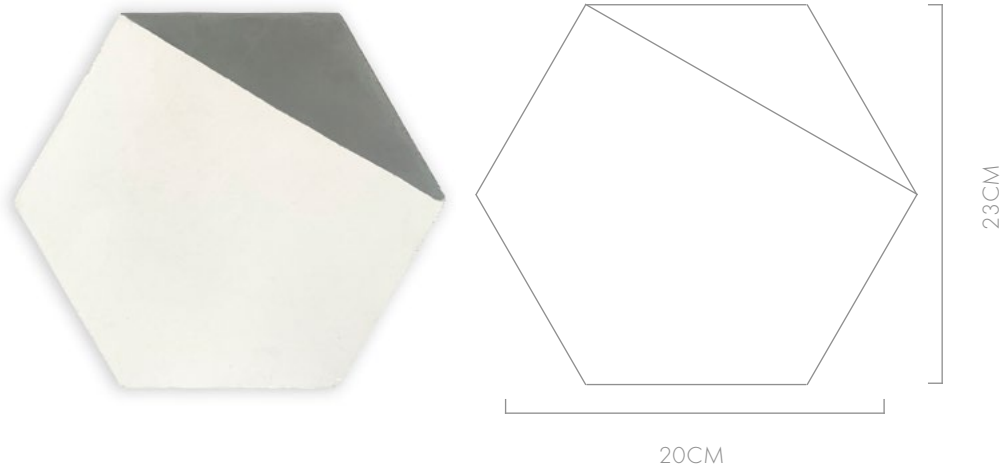

SQUARE 243 /

20 cm x 23cm x 1.2cm (thick), R1150/box, excl VAT
Each box includes 12 tiles, covering an area of 0.48 sqm

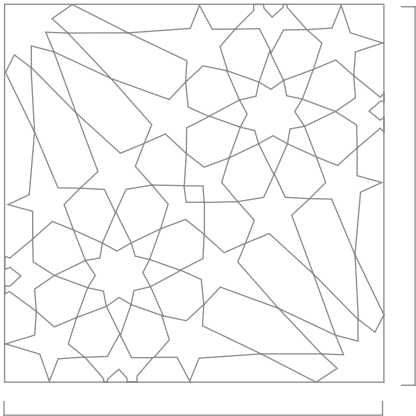
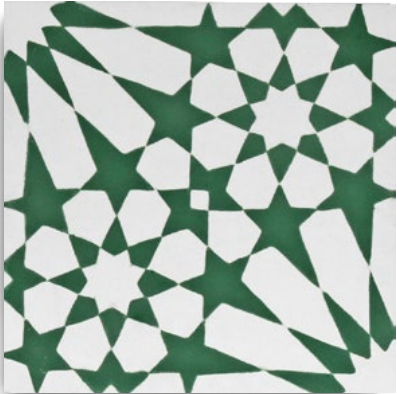

20CM

20CM



SQUARE 282 / SOFT GREY

20 cm x 20cm x 1.2cm (thick), R1150/sqm, excl VAT
Each box includes 12 tiles, covering an area of 0.48 sqm

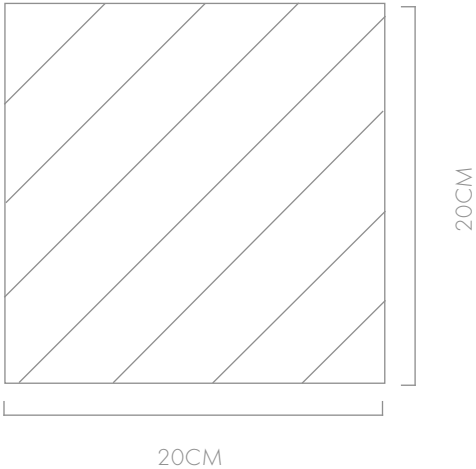

CONCRETE TILES / CARE GUIDE

Popham designs bi-encaustic cement tiles are handcrafted in Marrakech. The beauty of the hand-made process results in subtle colour variations. A chalky residue appears on the raw, uninstalled tiles and is the product of the time-honoured production process. Some light shadowing will remain after installation and cleaning, and is an inherent part of the tile. Tiles retain moisture from the manufacturing process and will dry to their correct colour a few days after installation. The final installed patina differs from the raw state of the tiles, and it is important to follow the steps below to ensure this result is achieved. Exterior applications may experience some fading over time due to UV exposure and this is more obvious in the blue and green colours.

INSTALLATION

Before installing the tiles, batch mix them from multiple boxes since nuanced colour variations are inherent in the manufacturing of the tiles.

Laying tiles on a wooden floor:

This must be carried out by an experienced professional. Laying tiles on wooden floors always entails a substantial risk, for several reasons: A wooden floor may be subject to bending movements or deformations, particularly in the case of overloading due to laying tiles. Wood is sensitive to moisture, whether it is the humidity in the air, or that in the high-bond mortar used, and swells, moves or becomes deformed by it. Floors and wood have many joints between planks and panels that need to be neutralized to avoid shearing or cracks. Nevertheless, an experienced professional can, under the right conditions, lay the tiles in an acceptable way, by fixing, loosening, waterproofing, leveling and filling the joints on the substrate in accordance with good trade practice, and laying the tiles with a sufficiently thick layer of very flexible high-bond mortar to absorb the movement and the unevenness of the substrate.

Cleaning and Sealing:

It is essential that the surface of the tile is level, clean, and perfectly dry. Wash the tiles using a mild soap and water and a Scotch-Brite pad or a fine-grained (400+ grit) sandpaper. This will give the tiles a wonderful, smooth surface texture and will remove any surface dirt or irregularities, including small chips on the edges of the tiles. Allow the tiles to dry thoroughly (approx. 24 hours) before proceeding.

It is essential that each and every tile is carefully sealed before installation.

Laying the Tiles:

Work in small areas of just half a square meter at a time so that the tiles can be cleaned properly as they are installed. Patterns look best with small grout joints (about 1 mm). Cement tiles should be installed with thin-set mortar, using a double-adhesive process, whereby the mortar is applied to a clean, level substrate and to the back of the tile using a trowel or wire brush. If setting the tiles on a concrete slab

on grade, provide a moisture barrier, and if not on grade, be certain the concrete substrate is fully cured to prevent white efflorescence spots from showing on the tile after installation. Submerge the tiles in clean water before they are laid to remove any dust from the back of the tile. During installation, tiles should be gently pressed into place by hand; never strike the tiles with a hammer (even a rubber hammer) as this will cause cracking.

Grouting the Tiles:

Tiles should be allowed to set for 24 hours before applying grout to the joints with a trowel or sponge.

Non-pigmented, flexible, un-sanded cementitious grout is recommended. Care must be given to wipe down the surface of the tile immediately following placement to keep the mortar or grout from setting in the tiles' porous surface. If any cement residue remains on the face of the tile, a Scotch-Brite pad or fine-grained sandpaper can be used to gently remove the residue. Much care should be taken if doing this as it is easy to damage the seal on the tiles and actual surface of the tile. If the tiles are being cleaned properly as you work you should not have this issue.

Sealing and Cleaning the Tiles:

Once the tiles have been grouted and properly cleaned, it is important to leave them to dry completely. This can take between 12-24 hours. Apply another layer of sealant, and allow to dry again. Please make sure you contact the manufacturer as they can give you full directions on the best way to apply their products and dilution levels for encaustic tiles. Once the tiles have dried, they should be washed with water and a mild soap to remove any chalky residue, which may appear as the tiles dry. Never use bleach or other acidic products on the tiles. Leave the clean tiles to fully dry for about a week.

MAINTENANCE

One of the attributes of cement tiles is that they improve with age and wear and cleaning. The tiles should be regularly washed with mild soap and water. Again, never use bleach or acidic products to clean the tiles. Depending on the level of luster you desire, additional coats of sealant can be applied as the tiles' finish become duller. When the sealants are rubbed into the tiles and polished, a lovely lustrous patina can be achieved. The type of sealant, as well as the number of coats, will impact the look of the tiles, which naturally have a matte finish. Depending on the traffic on the floor, the chemical sealant should be re-applied every few months for optimum effect.

RESOURCES:

www.tfc.co.za





ZELLIGE/

Zellige are the beads of the tile world and probably among the most iconic representation of Morocco.

Today, as the famous little glazed terracotta square continues its journey, it has adapted to modern interiors, imparting its luminosity on every wall or floor.

The traditions used to acquire the irreplaceable colouring from a rich terracotta have not varied since they appeared in the Moresque architecture a millienium ago.

Fez and Meknes in Morocco are still the production centres for zellige tiles due to the Miocene grey clay, primarily composed of Kaolinite present in that region. Zellige making is considered an art in itself and transmitted from generation to generation by maâlems (master craftsmen). An extensive training starts at childhood to implant the required skills.

Assiduous attention to detail is needed when creating zellige. The small shaped (cut according to a precise radius gauge), painted and enamel covered pieces are then assembled in a geometrical structure as in a puzzle to form the completed mosaic. The process has not varied for a millennium.

The subtle interplay of various colours is created by the different shapes and shades from one square to the other. Each piece is never quite the same, nor entirely different from its neighbour. The singularity of each of these items is best expressed in its simplest version, where there is nothing to distract from the subtle interplay of variations of colour.

The Zellige is the delicate reminder that differences make us richer...



ATELIERS ZELIJ/

Their unique creations are a mix of influences and an appreciation for the art of zellige: a bridge between two cultures.

Born from the meeting of two designers Samir Mazer & Delphine Laporte, Ateliers Zelij is undoubtedly one of the best mirrors of Moroccan art.

Attached to the Moroccan cultural richness, Les Ateliers are passionate about the fusion of design & craftsmanship. Through their journey, they break the form, play with contrasts & shades and thus project the zellige in the new world. Their unique creations are a mix of influences and a great respect for the art of zellige: a bridge between two cultures.

Ateliers Zelij was founded with a vision to create an open and united creative industry that promotes social and environmental progress. With a responsible design approach of combining traditional technique with a contemporary pattern, these designers have reintroduced Zellige back on to the front page of surface trends.

What sets Ateliers Zelij apart in the industry of zellige is their ability to develop pieces of art dedicated to urban projects where mobility is at the heart of its concept. Today, these designers are a reference for the creation and the production of zelliges, recognised by leading architects agencies and international brands. Their competence in the manufacture of antic models, as well as their ability to create contemporary surfaces, position them as surface experts.

Opia Design is the proud distributor of Ateliers Zelij in South Africa. For their full range visit their website: [zelij.com](https://www.zelij.com)

THE CLASSIC / ZITI

10 cm x 10cm, R1705/m2, excl VAT
Each box covers an area of 1 sqm



THE CLASSIC / BURGUNDY

10 cm x 10cm, R1705/m2, excl VAT
Each box covers an area of 1 sqm



THE CLASSIC / PETROL BLUE

10 cm x 10cm, R1705/m2, excl VAT
Each box covers an area of 1 sqm

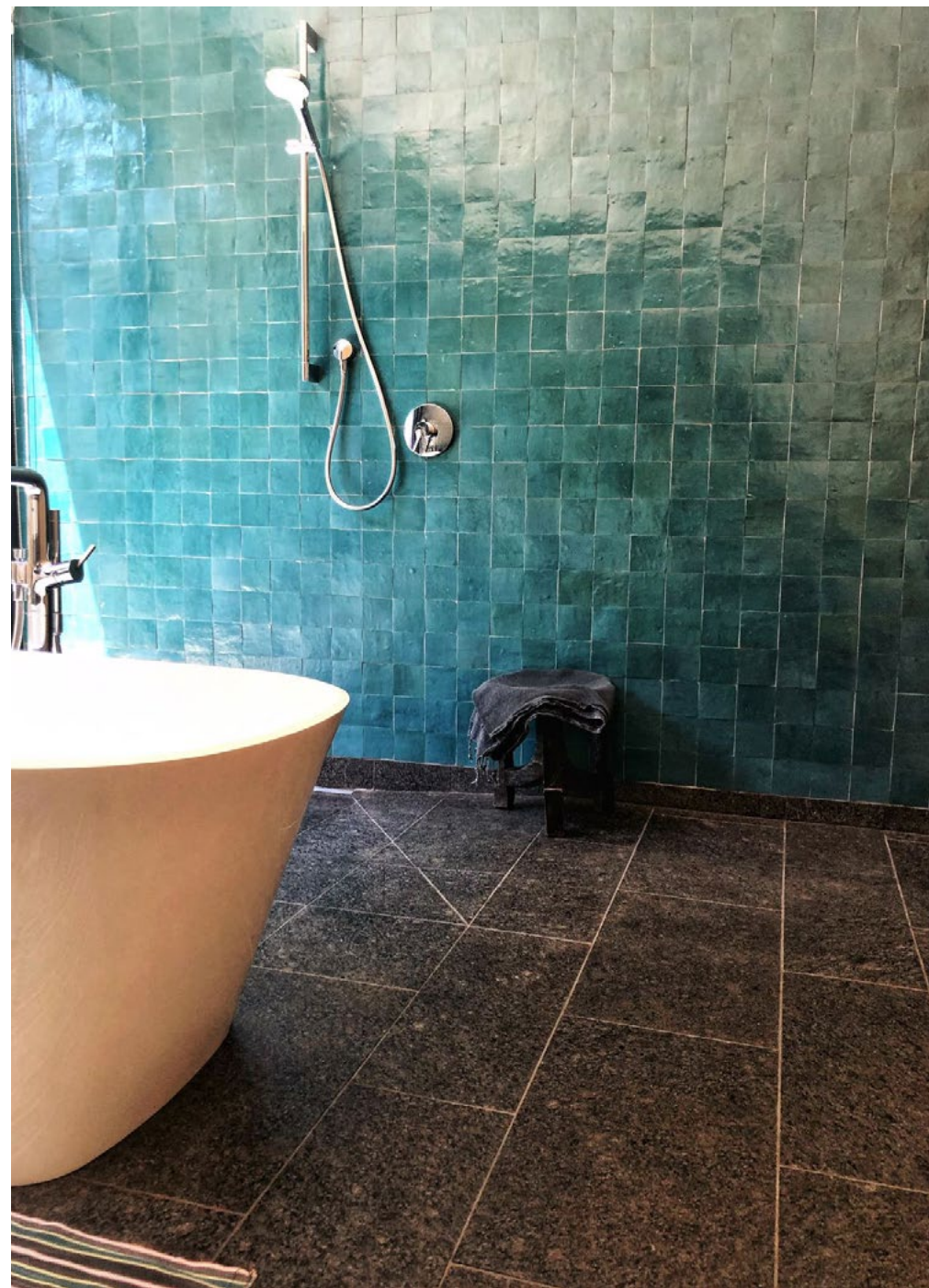

THE CLASSIC / HONEY

10 cm x 10cm, R1705/m2, excl VAT
Each box covers an area of 1 sqm

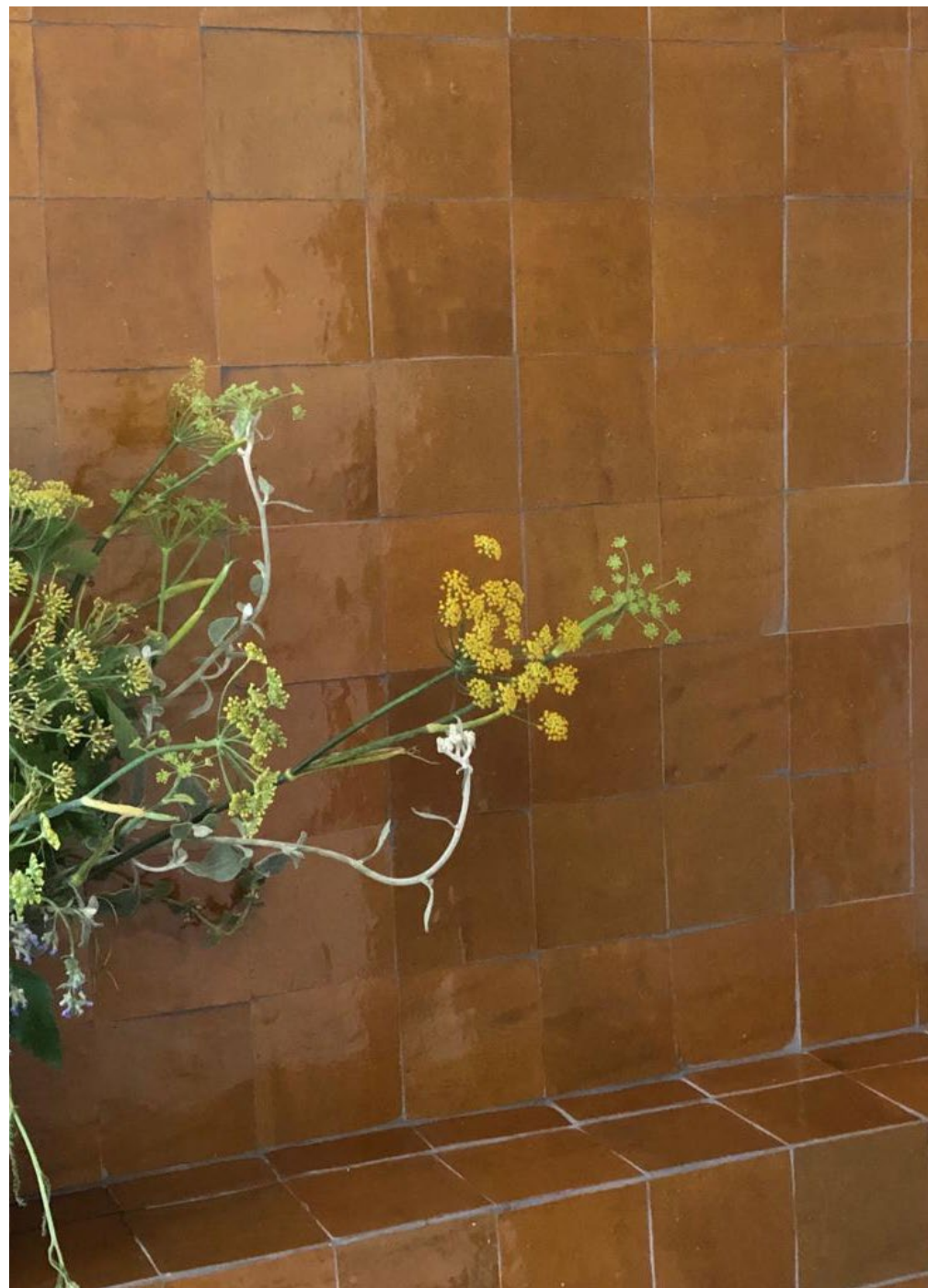
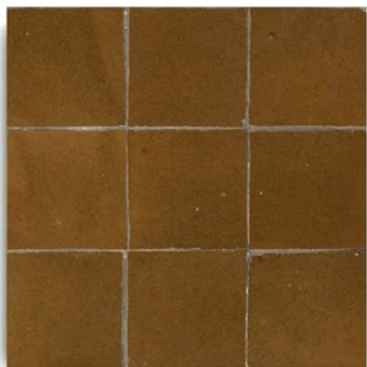

THE CLASSIC / BLUE-GREY

10 cm x 10cm, R1705/m2, excl VAT
Each box covers an area of 1 sqm



THE CLASSIC / BLACK

10 cm x 10cm, R1705/m2, excl VAT
Each box covers an area of 1 sqm



THE CLASSIC / OFF-WHITE

10 cm x 10cm, R1705/m2, excl VAT
Each box covers an area of 1 sqm



THE CLASSIC / ROSE POUDRÉ

10 cm x 10cm, R1705/m2, excl VAT
Each box covers an area of 1 sqm



THE CLASSIC / CELADON

10 cm x 10cm, R1705/m², excl VAT
Each box covers an area of 1 sqm

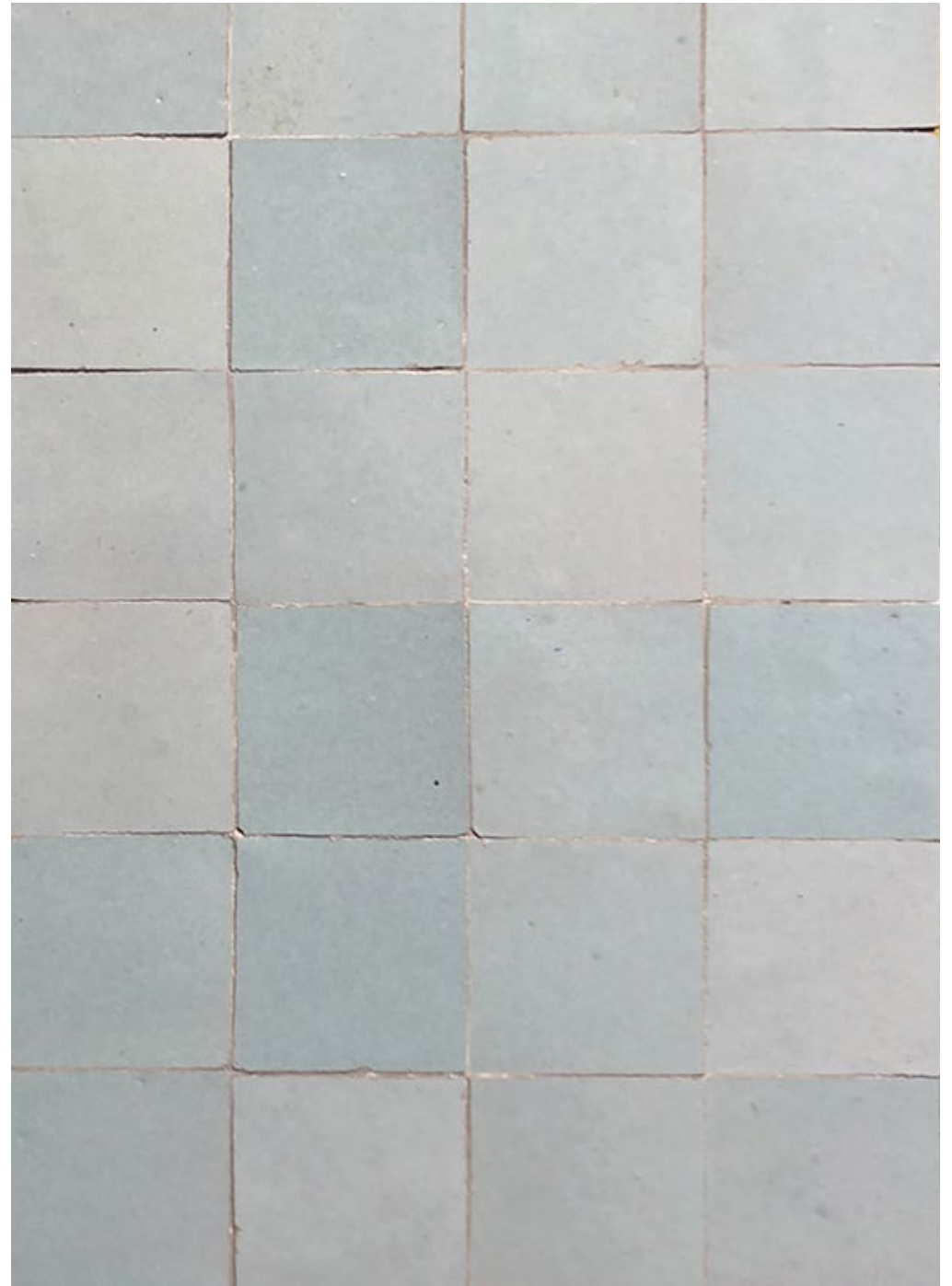

THE BEJMAT / EMERALD GLAZED

15 cm x 5 cm, R1610/box or R2146/m², excl VAT
Each box covers an area of 0,75 sqm



THE BEJMAT / NATURAL

14,5 x 4,5cm, R740/box or R1480/m2, excl VAT
Each box covers an area of 0,5 sqm



4.5 CM

14,5 CM



TRC9-3 / OFF-WHITE

Pre-assembled 30x30 cm R3395/m2, excl VAT
Each box covers an area of 1 sqm

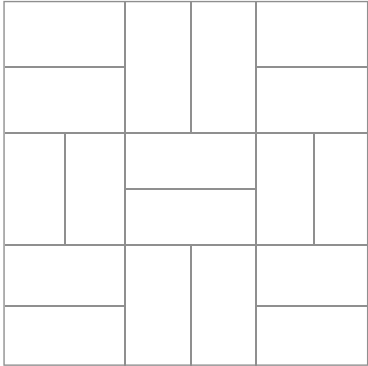

CREATIVE COLLECTION / TRC7

Pre-assembled 30x30 cm R4700/m², excl VAT
Each box covers an area of 1 sqm

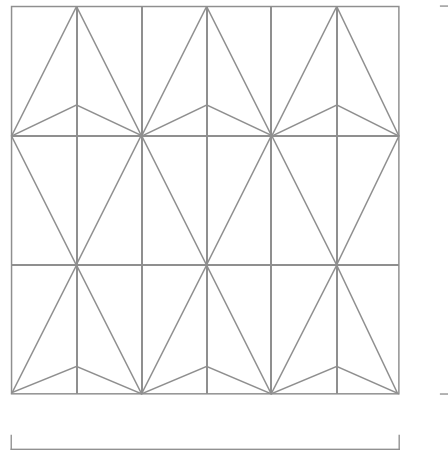

30 CM

30 CM





ZELLIGE / CARE GUIDE

Moroccan zellige tiles are known for the movement and shine that comes from all their irregularities and the wildly asymmetrical shade variations of their inimitable glaze.

There will always be minor defects which, taken in isolation, may seem unacceptable, but which contribute to the subtle overall appearance. So, there is no reason to sort the zelliges so as only to use "perfect" tiles. Our zelliges are already subject to very strict selection during manufacture, and it should be borne in mind that there is an inherent contradiction in wanting tiles that are traditional in character, at the same time as wanting total uniformity. Zellige installation is simple, but different from the usual tiles installation. Enamelled or glazed zellige are suitable for wall and floors exposed to moderate traffic. Nowadays, tilers are used to laying tiles with a wide joint. It would be a real pity to lay zelliges in this particular way, because they were not designed for that, and the presence of a wider joint detracts from the rhythm and the natural curves offered by the zelliges. A tiler who is used to handling sometimes perfectly sized industrial tiles will initially be disturbed by the irregularities of the zelliges, but will not have any particular difficulties with laying them.

INSTALLATION

Planning the Layout:

Before installing the tiles, batch mix them from multiple boxes since nuanced color variations are inherent in the manufacturing of the tiles. Always verify the conformity of the tiles before laying, Verify the beginning of the work and its evolution. Showers, baths: all Zelliges are appropriate for showers, hammams, spas, basins, swimming pools etc.

Laying the Tiles:

It is necessary to make a double spread forming a coat of at least 3 mm after laying to have the whole tiling stick to the wall area. This is meant to absorb the thickness disparities inherent in the handcrafted features of the product. A special tile grade glue-cement will be the best.

Make sure that the whole surface of the zellige is in contact with the high-bond mortar (otherwise an overhanging tile may crack in the corners).

The laying of the slabs or tiles must be carried out « edge to edge » tile against tile, with less space as possible. Once the grouting is done, the whole pattern appears with its specificities.

The irregular character of zelliges means that in certain places, it must be accepted that the joint will be slightly wider. There can be differences in thickness between zelliges of approximately 1.5 mm and they are never perfectly flat. Adjust the zelliges alongside a taut string and in relation to each other so that the edges touch as far as possible, so as not to leave any sharp edge exposed.

Laying tiles on a wooden floor: must be carried out by an experienced professional. Laying tiles on wooden floors always entails a substantial risk, for several reasons: A wooden floor may be subject to bending movements or deformations, particularly in the case of overloading due to laying tiles. Wood is sensitive to moisture, whether it is the humidity in the air, or that in the high-bond mortar used, and swells, moves or becomes deformed by it.

Special treatment of natural unglazed zellige

In the case of 'natural' unglazed zelliges, use a grout containing few additives. We recommend a water-resistant grout for thin joints. Unglazed zelliges are matt terracotta and are highly porous. They absorb stains very easily. Therefore it is essential to fill the surface.

Just before grouting, wet the joints until they do not absorb any more water. This is essential for filling thin joints and to prevent the jointing product from penetrating into the slightly porous surface and thus forming a veil of cement, which is invisible while wet, but tarnishes the appearance of the surface when it dries.

Use a very liquid grout, never a pasty one. Grout very quickly, working on small areas at a time, and clean with water to which a household detergent has been added, immediately after grouting. This way of working should avoid the forming of a cement veil on the surface of the 'natural' zelliges.

Clean the tiles thoroughly with water to which a household detergent has been added before surface filling (any grout stain or veil which is not removed at this stage is liable to remain on the tiles until the next thorough cleaning). Use a stiff brush or a scouring sponge (Scotch-Brite).

Grouting of glazed zelliges:

Brush the voids of the tiles under clear water with a brush which needs to be a little rough to lighten the joints to the maximum before grouting. We recommend using a beige or terracotta-color non-sanded grout. Both joints and defects will thus become homogeneous. Use a very liquid grout, never a pasty type. This is essential for filling thin joints. Let it dry completely.

MAINTENANCE

One of the attributes of zellige is that they require very little maintenance. The tiles should be regularly washed with mild soap and water. Again, never use bleach or acidic products to clean the tiles. For "natural" unglazed zelliges, use a fatty soap for natural stone or terracotta floors. Possible regular waxing. Polish to produce a shine. Wash after waxing to obtain a satin finish.



CONTACT /

Visit opiadesign.co.za and join our mailing list to be the first to know about new product launches and order deadlines.

Our operating hours are Monday to Friday from 10am-6pm.

If you are interested in purchasing our products, please get in touch with our sales team:
info@opiadesign.co.za

For all media inquiries and requests, please get in touch with our creative team:
media@opiadesign.co.za

For urgent enquiries contact us on 072 903 5979

