



CONCEALED HINGES

CLIP - ON HINGES

A premium worldwide brand associated with Roco Fittings for over 25 years.
FGV is built on quality & reliability.

CLICK HINGE INTEGRA WITHOUT DAMPER - FGV				
CODE	IMAGE	FIXING TYPE	TECHNICAL DRAWING	OPENING ANGLE
R515SH50500C500 0mm 110 Deg - Screw Fixing				
R515SH60500S500 0mm 110 Deg Dowel Fixing				
R515SH50508C500 8mm 110 Deg Screw Fixing				
R515SH60508S500 8mm 110 Deg Dowel Fixing				
R515SH50515C500 15mm 110 Deg Screw Fixing				
R515SH60515S500 15mm 110 Deg Dowel Fixing				
R515H850545C500 45 Deg Screw Fixing				
R51AH860545S500 45 Deg Dowel Fixing				
R515WH50500C500 0mm 175 Deg Screw Fixing				
R515WH60500S500 0mm 175 Deg - Dowel Fixing				
R515H850590C500 90 Deg Blind Cnr Screw Fixing				
R51AH860530S500 30 Deg Screw Fixing				

CLICK HINGE INTEGRA WITH DAMPER - FGV

CODE	IMAGE		FIXING TYPE	TECHNICAL DRAWING	OPENING ANGLE
R51ASH50500C500 0mm 110 Deg Screw Fixing					
R51ASH60500S500 0mm 110 Deg Dowel Fixing					
R51ASH50508C500 8mm 110 Deg Screw Fixing					
R51ASH60508S500 8mm 110 Deg Dowel Fixing					
R51ASH50515C500 15mm 110 Deg Screw Fixing					
R51ASH60515S500 15mm 110 Deg Dowel Fixing					
R51AH850545C500 45 Deg Screw Fixing					
R51AWH50500C500 0mm 175 Deg Screw Fixing					
R51AWH60500S500 0mm 175 Deg Dowel Fixing					
R51AH850590C500 90 Deg Blind Cnr					

INTEGRA CLICK MOUNTING PLATE - SCREW FIXING

R525A01M5020000	2mm Screw Fixing	
R525A01M5040000	4mm Screw Fixing	

INTEGRA CLICK PLATE - X-PANDO DOWEL

R525AN5M5020000	2mm With X-Pando Dowels 5mm X 9.8mm	
-----------------	--	--

OMM V SHAPED

R525A42M50000	With CAM adjustment - Screw Fixing	
R525A33M50000	Screw Fixing	

INTEGRA CLICK PLATE - CAM ADJUSTABLE WITH EUROSREW

Code	Description	
R52RA47L502A500	2mm With Cam Adjustment & 14mm Euroscrews	
2MM CAM ADJUSTMENT WITH SELF TAPPER SCREWS		
R52RA44L50205000	2mm with Cam Adjustment & Stp Screws	

HINGES - FGV

GLASS DOOR HINGES

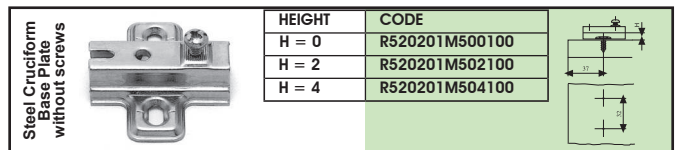
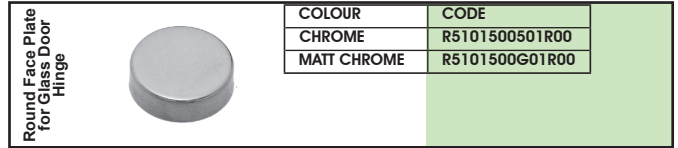

SHORT ARM HINGE / FRAME HINGE



ANTI-SLAM DEVICE & BRACKET

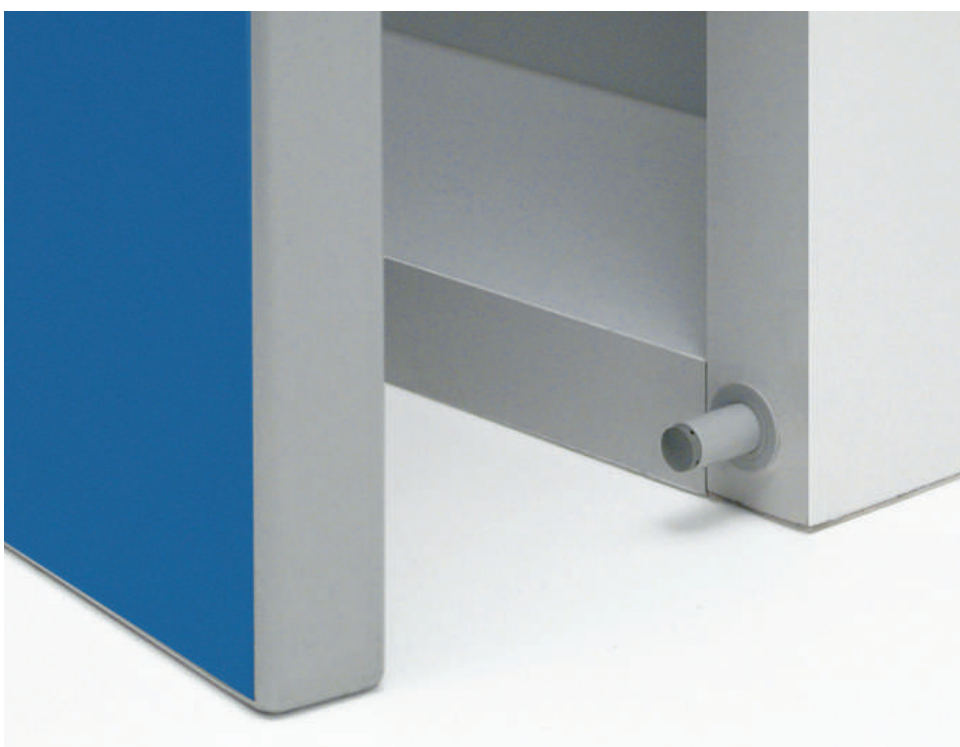

FGV ANTI-SLAM PISTON	
RFG595300	Anti Slam Device
FGV ANTI-SLAM & PUSH TO OPEN BRACKET	
RFG590337	Mounting Bracket



PUSH TO OPEN HINGES & MECHANISMS

R594200P610F00
**PUSH TO OPEN DEVICE WITH MAGNET +
 ADHESIVE PLATE**



RFG590337
**FGV ANTI-SLAM & PUSH TOP OPEN
 MOUNTING BRACKET**



IDEAL ASSEMBLY:

The One Touch device for door without handles has to be mounted in the corresponding area of the handle.

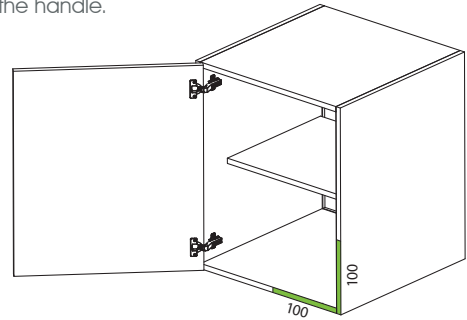

Installation without mounting bracket

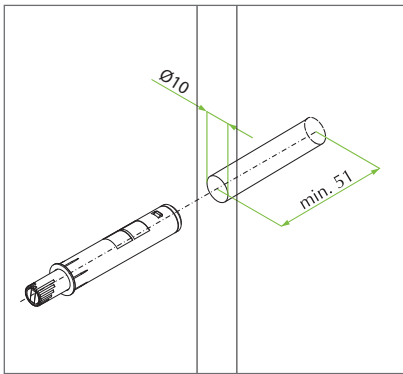



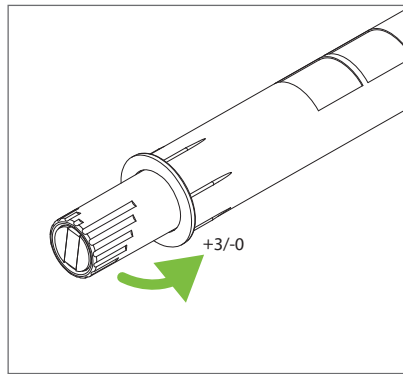



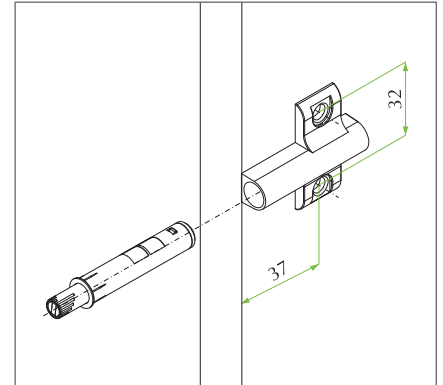

Adjustment

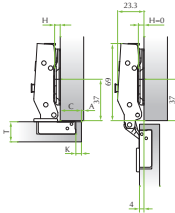

Installation with mounting bracket

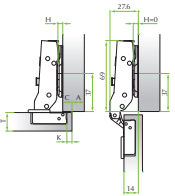

PUSH TO OPEN HINGES	FIXING TYPE	TECHNICAL DRAWING	OPENING ANGLE
R51MS15P5000000 0mm 110 Deg - Screw Fixing	 		 
R51MS15P5080000 SLIDE ON HINGE PTO 9mm - Screw Fixing FGV	 		 

Steel Cruciform Base Plate without screws

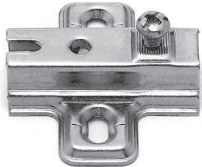

HEIGHT	CODE
H = 0	R520201M500100
H = 2	R520201M502100
H = 4	R520201M504100

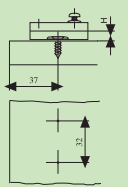

LEVA WALL HANGING BRACKET

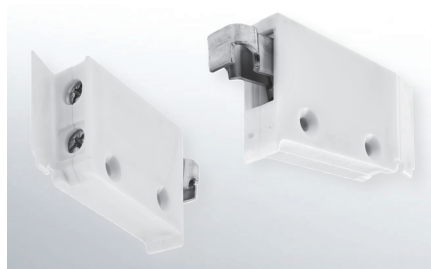
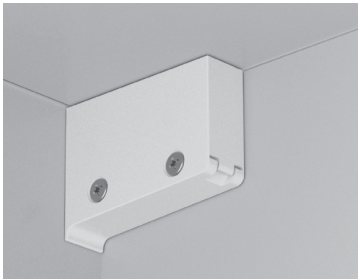

WALL HANGING BRACKET

R535753A100000 LEVA WHITE

- Fixing with wood/chip screws
- Symmetrical hook
- Front adjustment easy to access
- Adjustment screws to avoid accidental dismounting
- Flap for screws covering

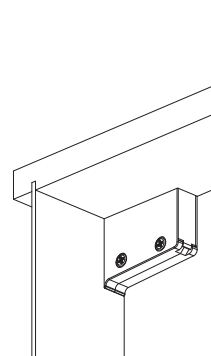
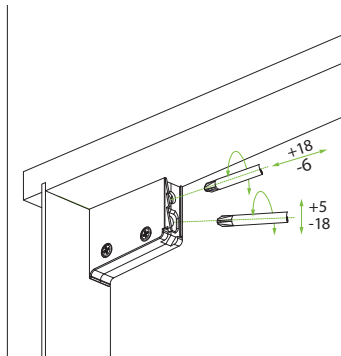
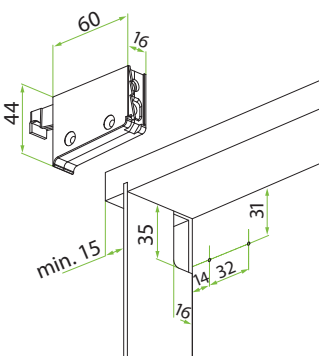

WALL HANGING PLATE

R22002707005CF 41X50mm

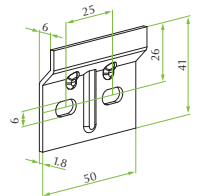
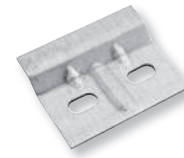

AEROWING LIFT MECHANISM



AERO WING LIFT STAY MECHANISM - FGV 37mm

R590VW0050000

Technical specifications:

- The three in one lifter solution:
 - self holding in all positions
 - self lifting and SlowMotion
 - flap with brake
- 32mm standard cabinet drilling
- Covers 75°, 90° and 105° angles
- Can be combined with slowmotion hinges

UP SOLUTION APPLICATION

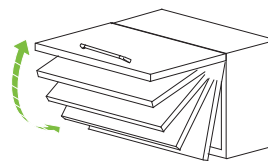

DOWN SOLUTION APPLICATION

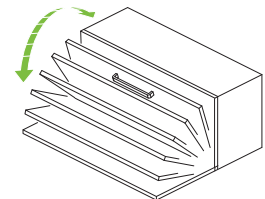

UP SOLUTION APPLICATION

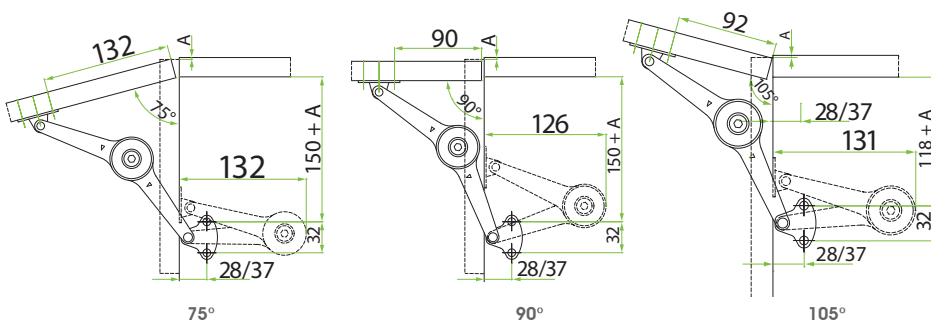

DOWN SOLUTION APPLICATION

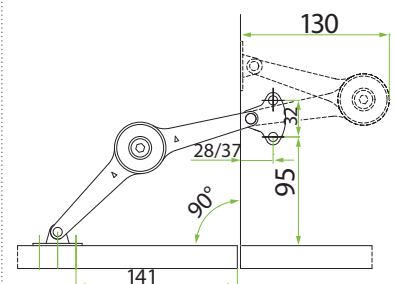

AEROPLUS LIFT MECHANISM

AEROPLUS LIFT MECHANISM - FGV
R590VPL05000000

- Upwards operation
- Symmetrical mechanism for a smart assembly
- Adjustable for doors up to 20kg weight
- Perfect stay in every position
- 32mm standard cabinet drilling
- Combined with SlowMotion hinges, it confers a perfect movement to the door

Door weight adjustment (kg)

Door height	F1	F2	F3	F4
300	1-2-3	4-5-6	7-8-9	10-11-12
400	3~5	5~10	9~15,5	11~20
500	2~4	3,5~7,5	6,5~11,5	8,5~15
600	1,5~3	3~6	5,5~9,5	7~12
600	1,5~2,5	2,5-5	4,5~7,5	6~10

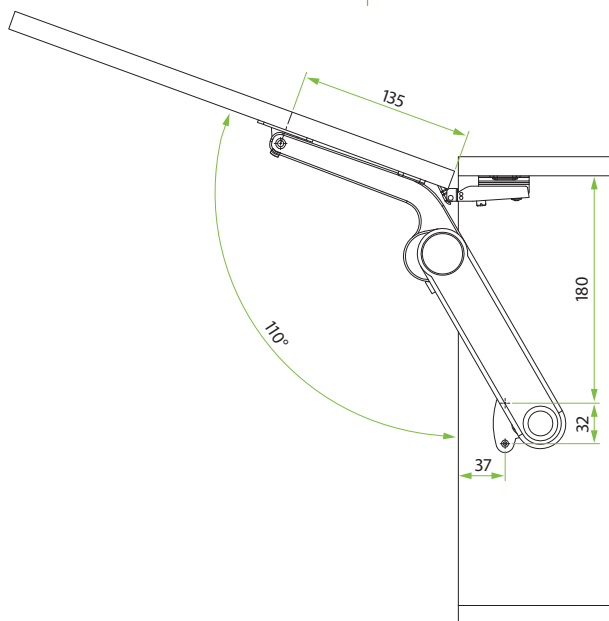
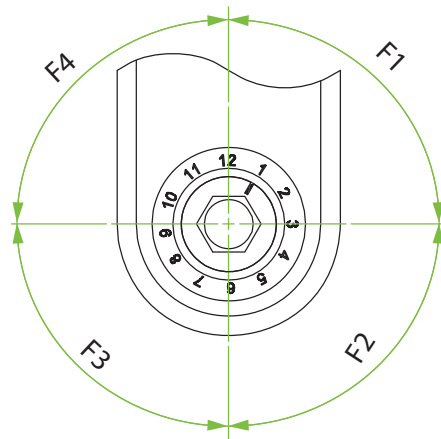
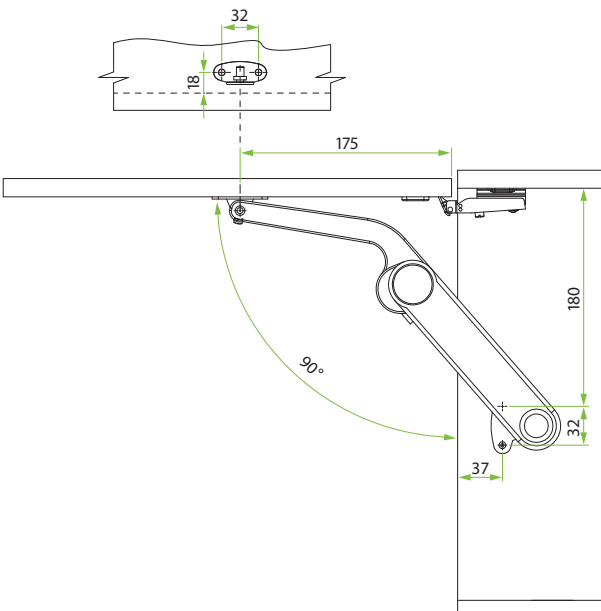
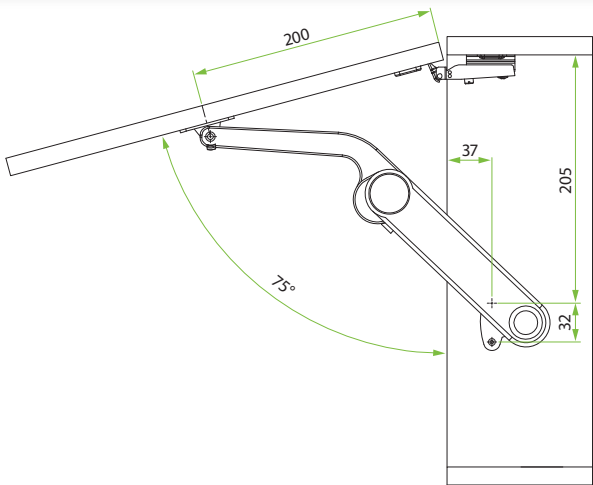

Values given in mm

AEROBUS LIFT MECHANISM



AEROBUS LIFT MECHANISM - FGV R590VBSA9D400

D40 - 2.4-5.5KG DOOR

Technical specifications:

- Upwards operation
- Easy and rapid assembly with click-on door fixing
- No hinges required
- No stabilization bar required
- Door and weight adjustments
- SlowMotion technology for controlled and silent closing

APPLICATION

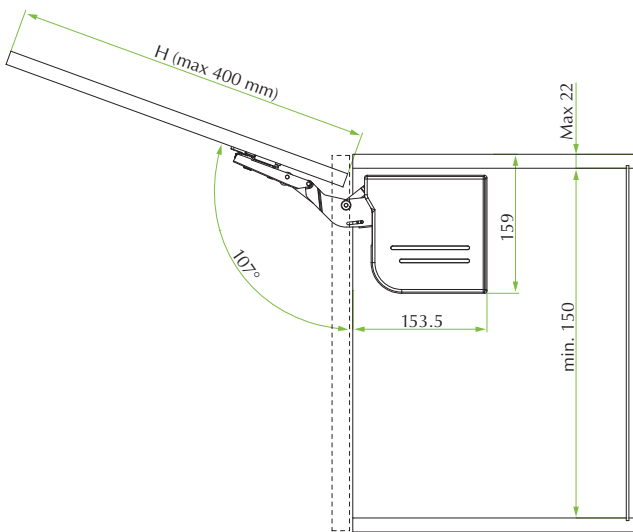
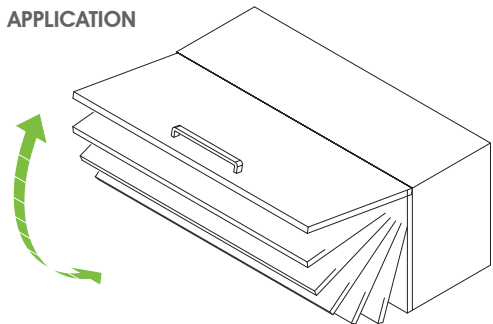

Cabinet fixing

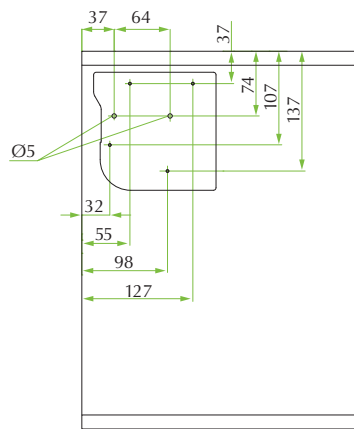

Door fixing

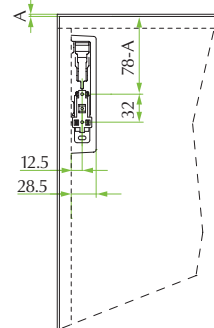

Adjustments:

Door adjustment

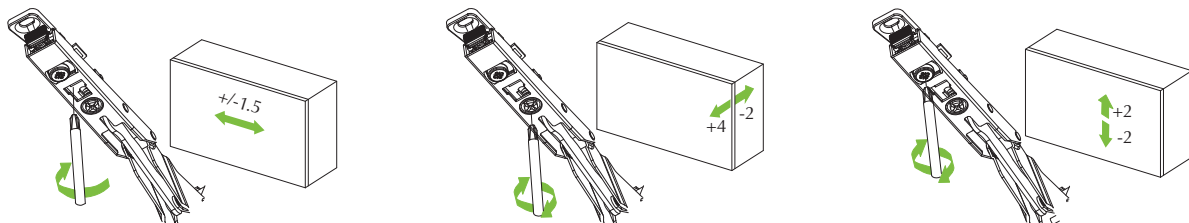

Weight adjustment

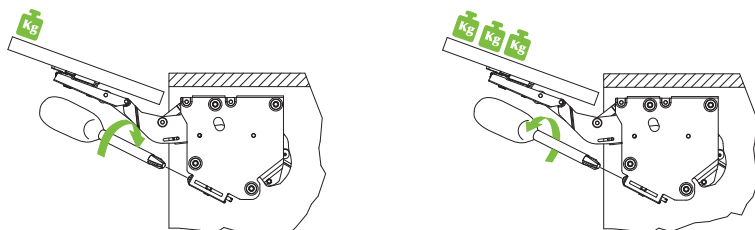

DOMINO W - FOLDING DOOR SYSTEM



TECHNICAL SPECIFICATIONS:

- Sliding system for folding hinged doors
- Max door width of 1000mm (500+500), max door thickness of 25mm
- Mechanism max load capacity of 50kg
- Door weight applied to the upper bar
- Application also without lower truck and lower bar

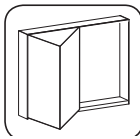

DOMINO W FOLDING DOOR KIT - FGV

R590DW0030000 | Folding Door Kit (Excluding Rails)

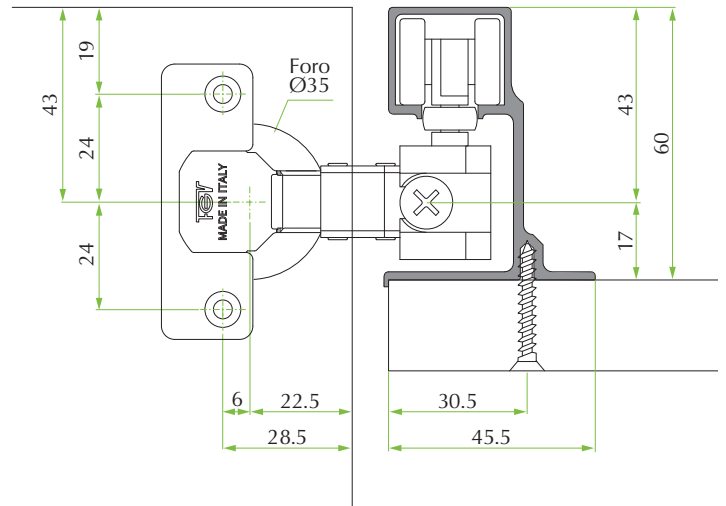
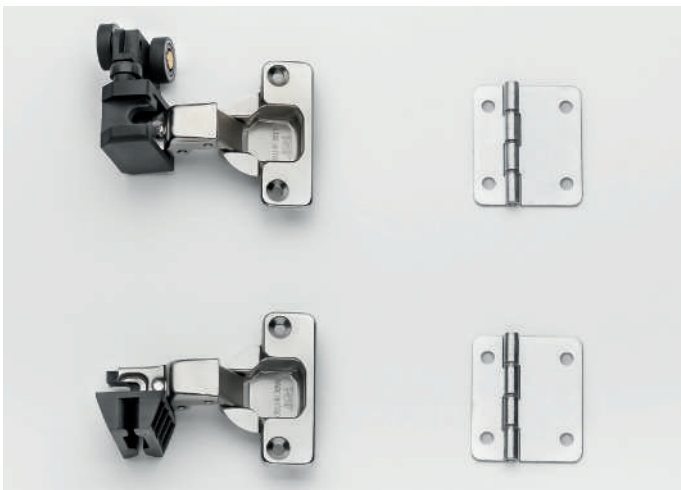

DOMINO W UPPER RAIL - FGV

R590DWB0ASI2000U | 2m Aluminium

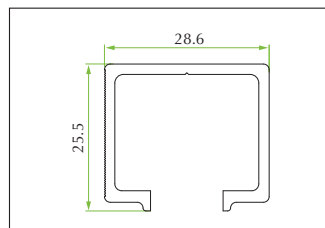

DOMINO W LOWER RAIL - FGV

R590DWB0AI02000L | 2m Aluminium

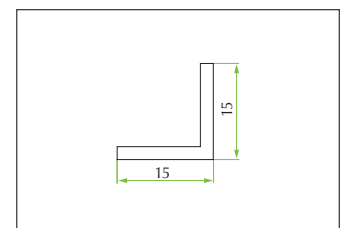







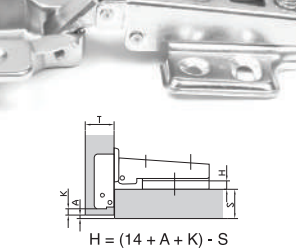

CABX SLIDE ON HINGE WITH MOUNTING PLATE

Economically sourced & priced ranges of hardware for the kitchen & Furniture industries

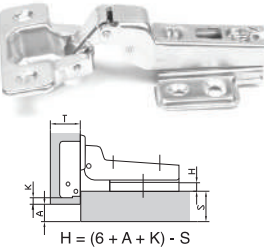
HINGE	DRAWING	SINGLE FORM	SINGLE WITH DOWELS	PREPACKED IN PAIRS
	 $H = (14 + A + K) - S$	AFTS145W34 110° STRAIGHT ALL METAL HINGE WITHOUT DOWELS Includes 4 Hole Mounting Plate Tested To 50 000 Cycles	AFTS145WD 110° STRAIGHT OMM ALL METAL HINGE WITH DOWELS Includes 4 Hole Mounting Plate	AFTS145W34P 110° STRAIGHT OMM ALL METAL HINGE without dowels Includes 4 Hole Base Plate 2 per pack
	 $H = (6 + A + K) - S$	AFTS245WI 110° 9MM OFFSET ALL METAL Hinge Without Dowels Includes 4 Hole Mounting Plate Tested To 50 000 Cycles	AFTS245WD 110° 9MM OFFSET ALL METAL HINGE WITH DOWELS Includes 4 Hole Mounting Plate	AFTS245W34P 110° OFFSET 9MM ALL METAL HINGE WITHOUT DOWELS Includes 4 Hole Mounting Plate 2 per pack
	 $H = A + K - 1$	AFTS345WI 110° INSET ALL METAL HINGE WITHOUT DOWELS Includes 4 Hole Mounting Plate Tested To 50 000 Cycles	AFTS345WD 110° INSET ALL METAL HINGE WITH DOWELS Includes 4 Hole Mounting Plate	
		AFQS145WI 45° HINGE ALL METAL WITHOUT DOWELS Includes 4 hole Mounting Plate Tested To 50 000 Cycles	AFQS145WD 45° HINGE ALL METAL WITH DOWELS Includes 4 Hole Mounting Plate	
	 $H = (14 + A + K) - S$	AFMS148WI 165° STRAIGHT CORNER HINGE ALL METAL WITHOUT DOWELS Includes 4 hole Mounting Plate Tested To 50 000 Cycles	AFMS148WD 165° STRAIGHT CORNER HINGE WITH DOWELS Includes 4 hole Mounting Plate Tested To 50 000 Cycles	

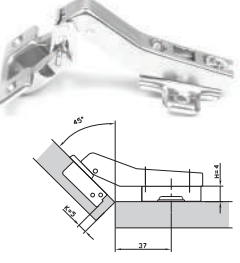
CABX SOFT CLOSING CLIP ON HINGE

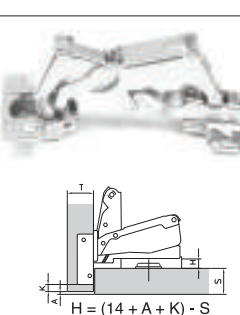
WITH INTEGRATED SOFT CLOSING DAMPER AND MOUNTING PLATE

SINGLE FORM	
 <p>AFTS6190 110° STRAIGHT OMM ALL METAL HINGE WITH INTEGRATED SOFT CLOSING DAMPER Includes 4 Hole Mounting Plate Tested To 50 000 Cycles</p> <p>$H = (14 + A + K) - S$</p> 	
 <p>AFTS6199 110° OFFSET ALL METAL HINGE WITH INTEGRATED SOFT CLOSING DAMPER 9MM Includes 4 Hole Mounting Plate Tested To 50 000 Cycles</p> <p>$H = (6 + A + K) - S$</p> 	
 <p>AFTST45 45° HINGE ALL METAL WITH INTEGRATED SOFT CLOSING DAMPER Includes 4 hole Mounting Plate Tested To 50 000 Cycles</p> 	
 <p>AFTS6195 165° CORNER HINGE ALL METAL WITH INTEGRATED SOFT CLOSING DAMPER Includes 4 hole Mounting Plate Tested To 50 000 Cycles</p> <p>$H = (14 + A + K) - S$</p> 	

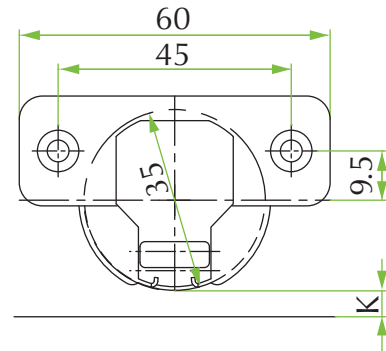

HINGE FIXING PLATE	
White	
RHINGEFIX	<ul style="list-style-type: none"> The Hinge Fxing Plate can be used to secure the cup or the mounting plate to the door and carcass.

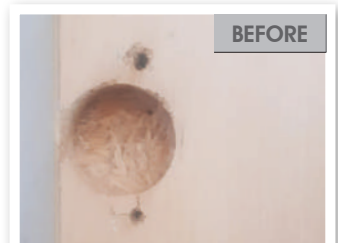

SALICE

BI-FOLD LIFT SYSTEM



SALICE BI-FOLD LIFT SYSTEM		MINIMUM			MAXIMUM		
		WIDTH	HEIGHT	KG	WIDTH	HEIGHT	KG
FLMF72XDSN9	720MM 150N+	400	691	3.50	1000	750	9.5
FLMF72XFSN9	720MM 400N+	1000	691	8.50	1500	750	14.5
FLMF91XDSN9	900MM 150N+	400	880	4.50	600	940	7
FLMF91XFSN9	900MM 400N+	600	880	6.50	900	940	10.5



WEIGHT OF THE TWO DOORS (KG)

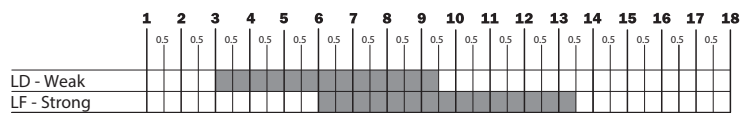

Total height of the two doors from 570 mm to 630 mm

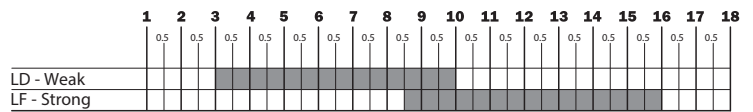

Total height of the two doors from 631 mm to 690 mm

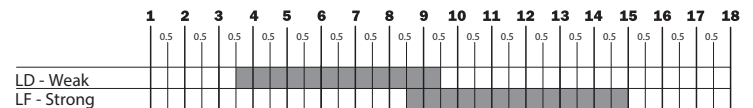

Total height of the two doors from 691 mm to 750 mm

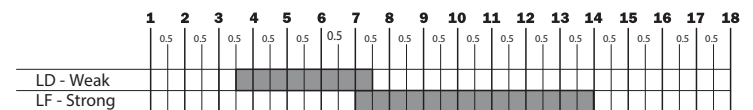

Total height of the two doors from 751 mm to 810 mm

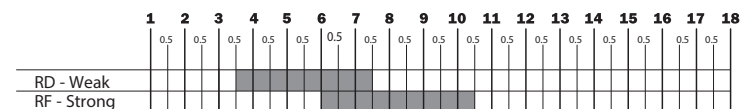

Total height of the two doors from 880 mm to 940 mm

SALICE

STANDARD LIFT SYSTEM



SALICE STANDARD LIFT SYSTEM		MINIMUM			MAXIMUM		
		WIDTH	HEIGHT	KG	WIDTH	HEIGHT	KG
FRMFXXDSN9D	RHD 150N+	600	320	2.50	1200	400	6
FRMFXXFSN9D	RHD 400N+	900	400	4.50	1000	600	7.5

DOOR WEIGHT (KG)

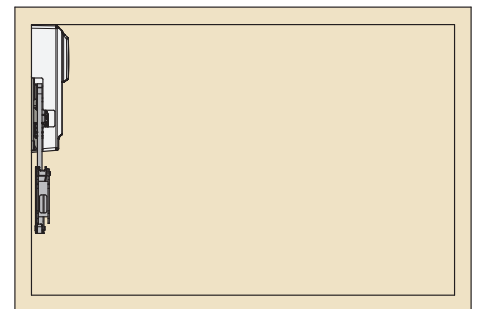
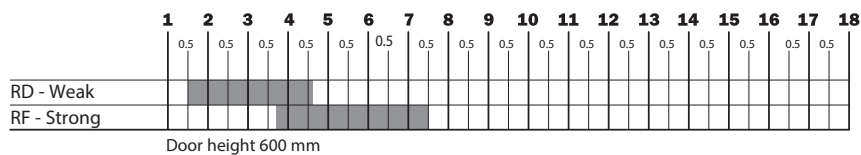
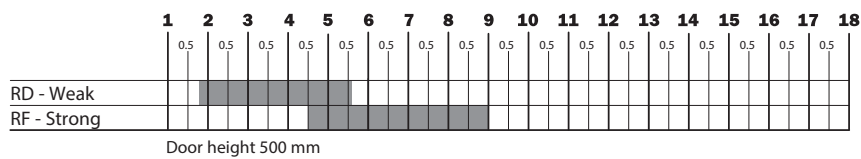
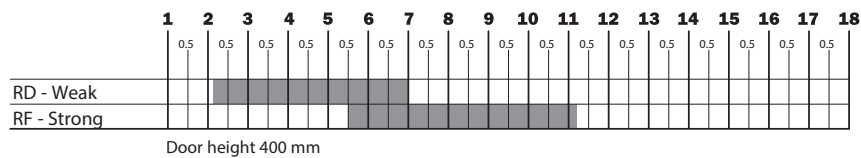
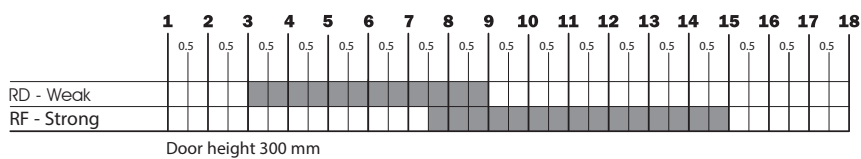

SALICE

PARALLEL LIFT SYSTEM



SALICE PARALEL LIFT SYSTEM		MINIMUM			MAXIMUM		
		WIDTH	HEIGHT	KG	WIDTH	HEIGHT	KG
FPMFLXXDSN9	440-600MM 150N+	500	440	2.50	800	600	6
FPMFLXXFSN9	440-600MM 400N+	900	440	5.00	1200	600	9
ADD SALICE TORSION BAR							
FPMF59QX739	900MM						
FPMF59Q1039	1200MM						

CHART TO SELECT THE EXACT SYSTEM SUITABLE FOR THE DIMENSIONS AND WEIGHT OF THE DOOR.

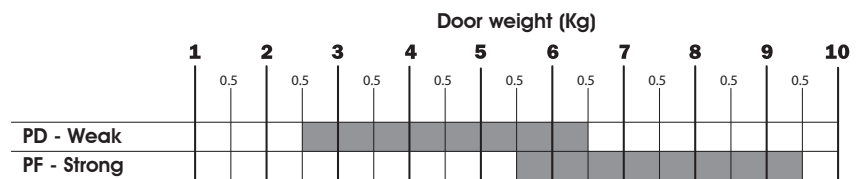

Door height from 360 mm to 600 mm



HINGES - OTHER

ECONOMICALLY SOURCED & PRICED RANGE OF HINGES FOR THE KITCHEN & FURNITURE INDUSTRIES

SELF CLOSING HINGES 5 KNUCKLE PER PAIR

RSCBB	Bright Brass
RSCBMA	Antique Copper
RSCGB	Georgian Brass
RSCCP	Chrome
RSCWH	White

SELF CLOSING HINGE 3 KNUCKLE

ASCH3AB	Antique Brass
ASCH3NP	Nickel Plated

PIANO HINGE

APHEB32COILS	32mm Electro Brass 30m Coils
APHSS32COILS	32mm Stainless Steel 30m Coils

FLUSH HINGES

AFH50EB	50mm Electro Brass
AFH50NP	50mm Nickel Plated
AFH50YP	50mm Yellow Passivated

BUTT HINGE

ABH50BR	50mm Brass
---------	------------

