

C A T A L O G U E

- █ LIGHTWEIGHT
- █ CONCRETE
- █ TILES

FLOAT

Natural aesthetic of concrete
embraces the imperfect
look and feel of
handmade raw finishes.

Our focus is on creating
relaxed surroundings
as an antidote to
the fast pace of modern life.

Welcome
to our
playground.

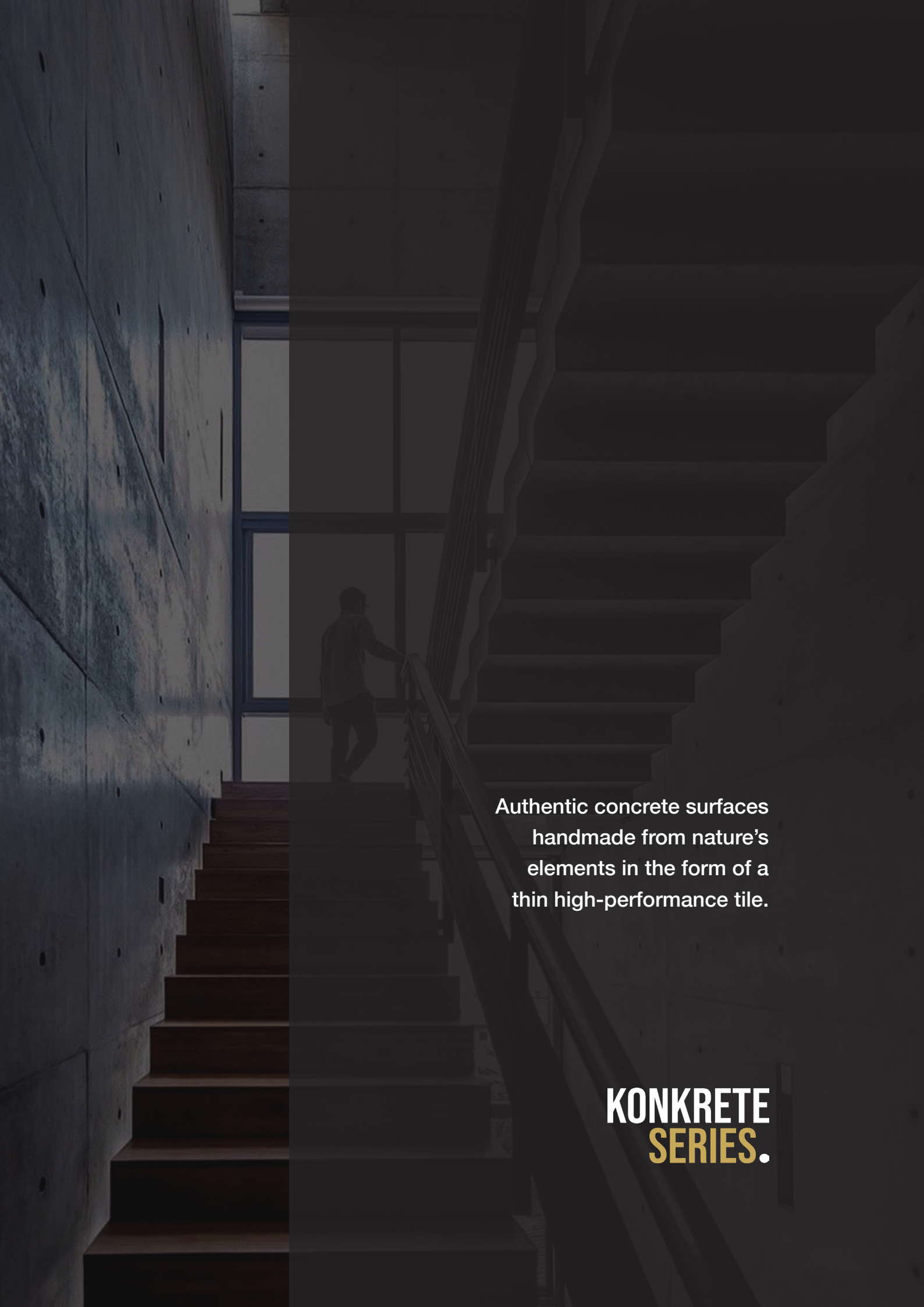

Authentic concrete surfaces
handmade from nature's
elements in the form of a
thin high-performance tile.

KONKRETE
SERIES.





“ A innovative concrete product that removes the risk of traditional in-situ casted concrete and simultaneously makes it more cost effective. “

- Brad Webber, Envirocon Group





**Architectural concrete without
the mess, cost and time.**



What makes our authentic concrete tiles a revolution in modern architecture?

- 1 Removes the risk of in-situ concrete casting
- 2 Cost effective vs traditional in-situ casting
- 3 Authentic concrete walls on re-modelling projects
- 4 CrystalX waterproofing technology
- 5 Can be installed by any qualified tiling professional
- 6 Lightweight and easy to handle
- 7 Reduces on-site construction time

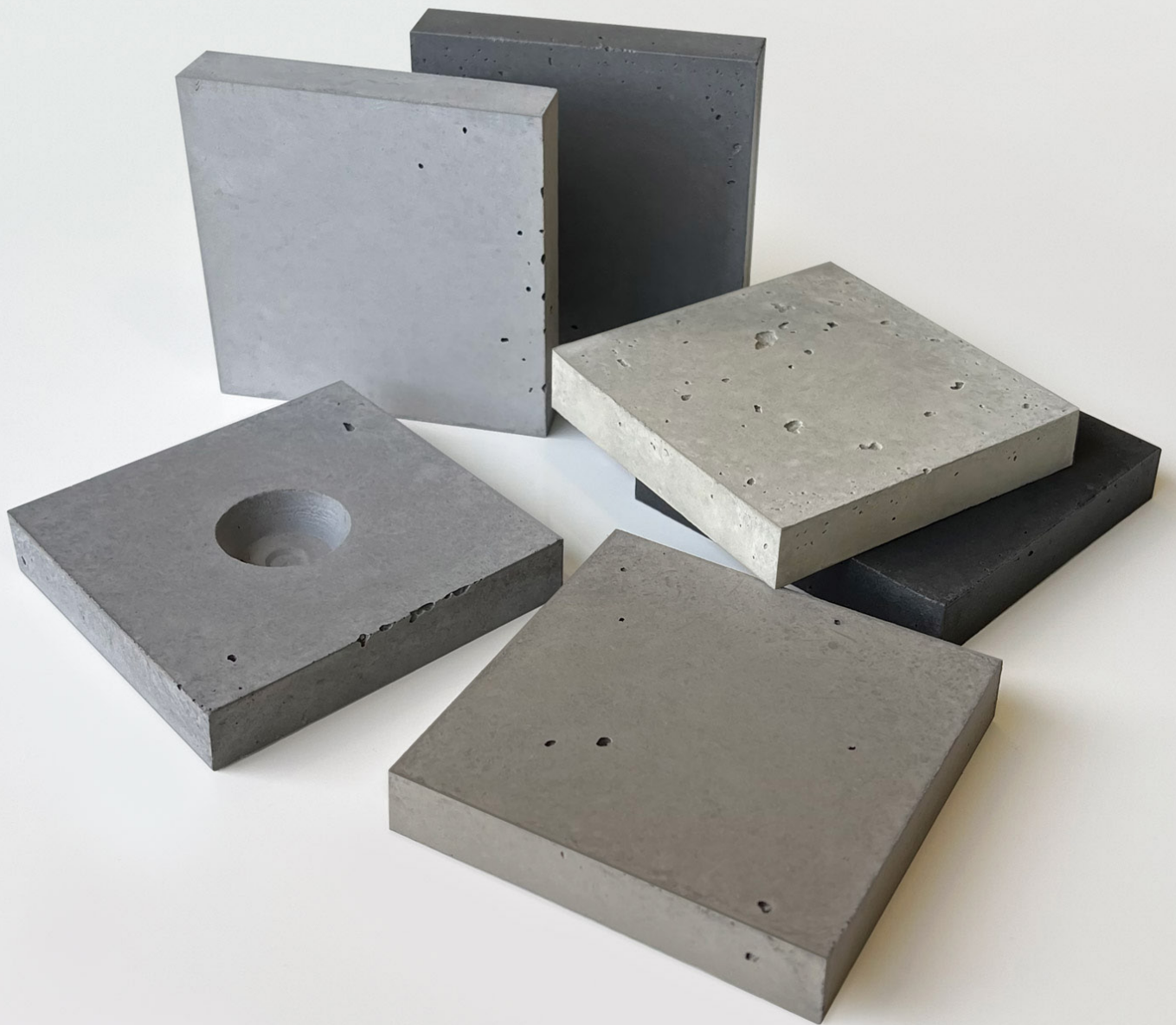

KONKRETE4

Size / 1200x600mm

Weight / 20kg

Orientation /
horizontal or vertical

Thickness / 14mm

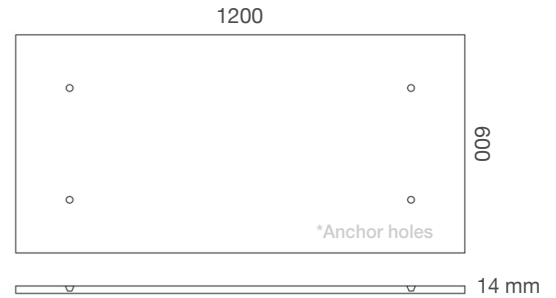

KONKRETE3

Size / 1300x530mm

Weight / 19kg

Orientation / Vertical

Thickness / 14mm

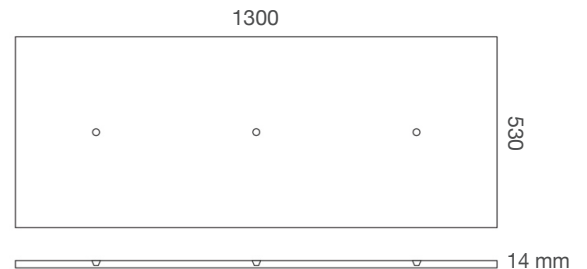
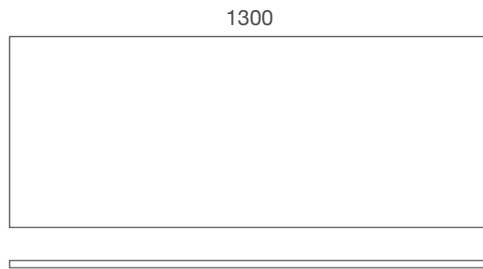

KONKRETE2

Size / 1200x600mm

Weight / 20kg

Orientation /
horizontal or vertical

Thickness / 14mm

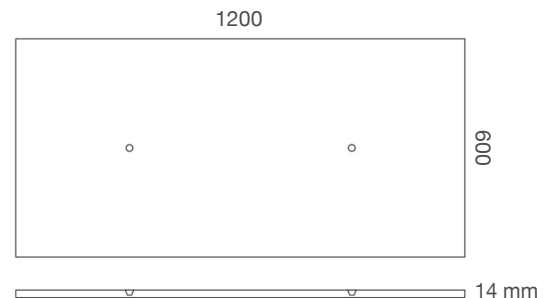
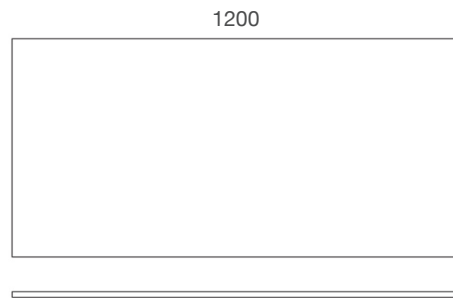

KONKRETE2 SMALL

Size / 1000x500mm

Weight / 14kg

Orientation /
horizontal or vertical

Thickness / 14mm

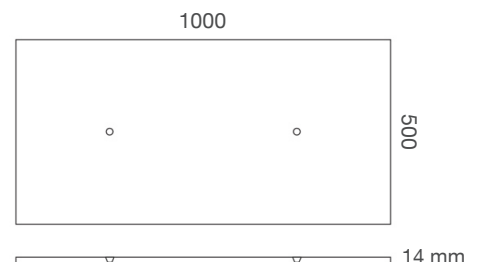
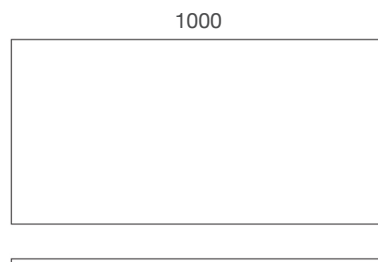

KONKRETESQUARE

Size / 600x600mm

Weight / 10kg

Can be used individually or
in conjunction with the other
concrete tiles as an end piece.

Size / 900x900mm

Weight / 21kg

Thickness / 14mm

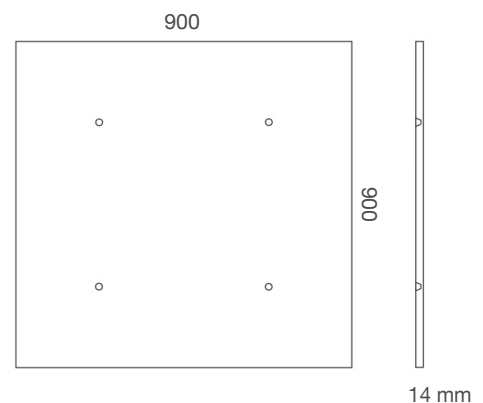
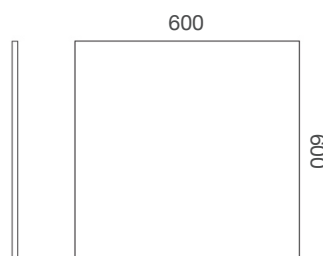



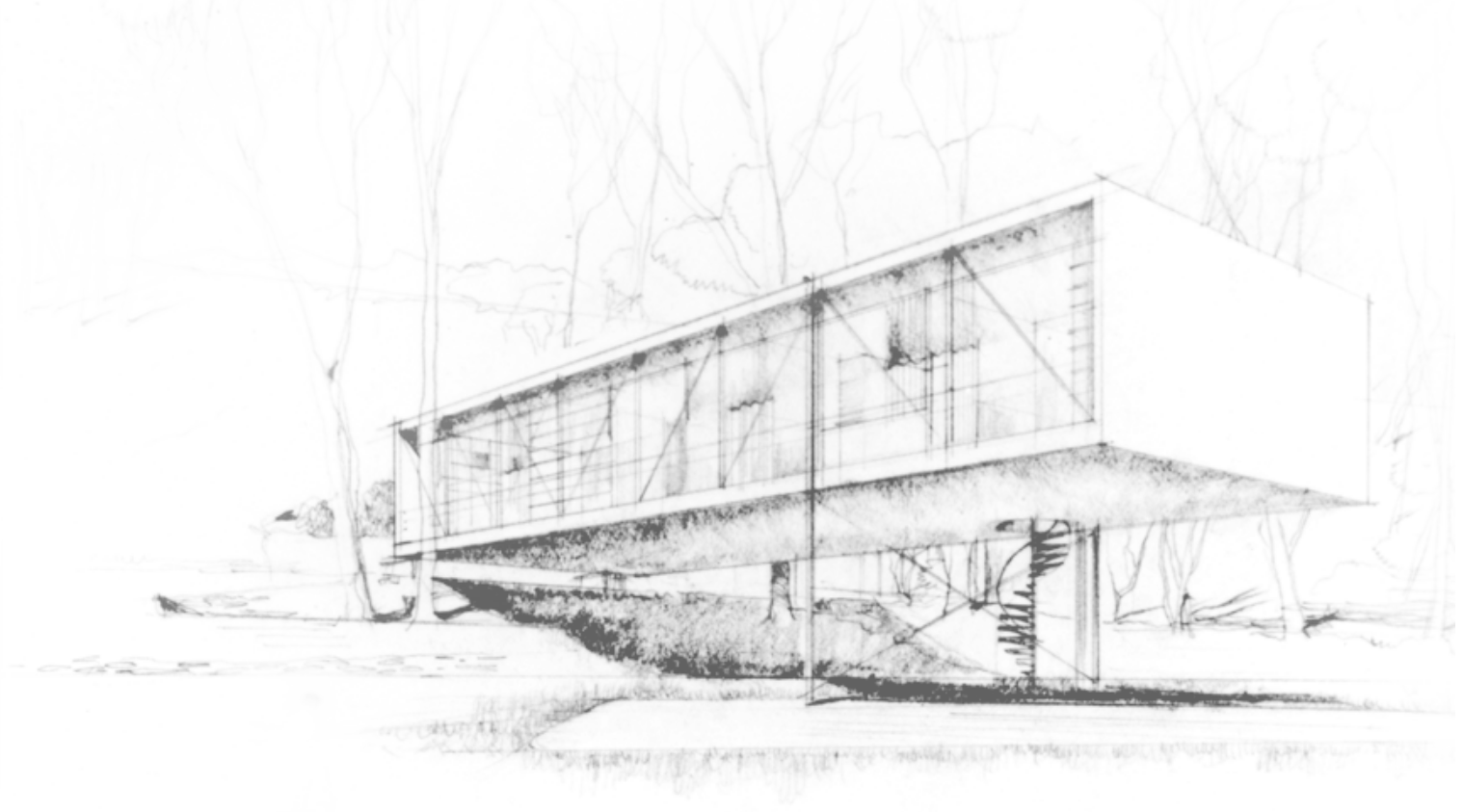

Concrete
doesn't need
to make a
statement,
it settles into
a space
**and allow
the other
features to sing.**



Product

Concrete

Concrete is one of the most influential, flexible and dynamic materials in modern architecture. The natural imperfect texture of its surface radiates a calming and organic feel to contemporary spaces and creates a unique atmosphere with a element of emotion. Being a breathing material moisture is naturally absorbed and released as the surrounding humidity changes making this a hygroscopic living material. All the materials used are sourced from nature and also cleaning up our precious environment at the same time. The authentic appearance of our concrete is a trademark and is not compromised to adapt to the protective and durability function of the product. Our mission of preserving this authenticity and character is well reflected in all our concrete products, essentially bringing concrete surfaces to life. Glassfibre reinforced concrete has led to a revolution in architecture as a durable and lightweight sustainable solution.

Material DNA

- 01** FLOAT tiles are produced with a well mastered manufacturing process that combines intelligent technologies with the finishing touch of human hands. This wonder material is made from **Ultra high-performance concrete [UHPC]** using a unique formula made up from minerals provided by nature. Advantages of UHPC offers durability, corrosion resistance and excellent thermal and sound insulation. Due to its extremely long lifespan, low maintenance and high level fire safety, it can be equally used for facades, cladding systems, indoor and outdoor decorative surfaces.
- 02** While preserving originality and natural character, FLOAT tiles reinterpret the typical robustness that is unique to concrete into a thin, high-quality product with pure surface aesthetics. Colour and texture variations are a completely harmless feature of our natural product. The aging of the concrete is a natural and aesthetically pleasing attribute that influences its appearance in a graceful manner.
- 03** Our glassfibre reinforced concrete mainly consists of various aggregates and cement. Glassfibers, colour pigments and concrete additives make up around 10% of the mix design. This combination makes our tiles extremely robust, durable and slim in thickness while still being able to withstand significant pressure. FLOAT tiles also meet the requirements of fire protection class A1 “non-combustible“ and is environmentally neutral as no additional treatment or chemical coatings are necessary for fire protection.





CONCRETE GREY

SMOKE

GUNMETAL

GRAPHITE

SAND DOLLAR

DESERT DUNE

Complexion

FLOAT tiles are coloured with natural iron oxide pigments and integrates well with surrounding elements while blending in with nature. Our tiles have consistent colouring throughout the entire product, the iron oxide is added during the production phase when blending all the raw materials, these oxides are UV stable and will not fade. Over time environmental factors like weather, air moisture and dirt will naturally age concrete.

Slight variations in raw materials can lead to colour differences between individual tiles or between different production batches. To avoid colour discrepancies we recommend ordering the total amount of tiles needed instead of part orders, attic stock tiles are always added to the initial order.

Note: Due to technical reasons digital/printed colours may differ from the actual natural shade. Custom colours can be produced upon request at an additional charge.

Surface

Our tiles are produced to naturally have imperfections and is not always uniform. Any cloudy or slightly spotty surface with hollows and texture should be seen as a natural characteristic of the concrete and not a defect. If a client or project specifically needs the tiles to be smooth with minimal texture, we can produce it on request.

We use innovative self-healing waterproofing technology and a water repellent sealer after the tiles are cured to prevent moisture entering the concrete which prevents hairline cracks on the surface.





Forged
from
the
past.
Shaped
by
the
future.

KONKRETE
SERIES.

Innovation

We specialize in the production of solution-orientated and environmentally friendly concrete tiles designed to imitate traditional off-shutter casted concrete. Inspired by the growing need to be more economical without compromising aesthetics and quality our product has become a great choice for architects and designers. Contractors are amazed with this product as it saves significant time during construction due to the ease of installation and no curing time involved. FLOAT tiles can be applied to any solid surface and can be used for new projects, remodeling projects, interior/exterior projects.

Waterproofing Technology

Our lightweight concrete tiles are produced with leading edge **CrystalX waterproofing technology**. The concrete has self-healing properties when in contact with moisture/water, this makes our product perfect for any weather conditions and application. CrystalX technology forms a waterproofing barrier in the pores and seals the concrete when in contact with moisture.

CrystalX is added during the manufacturing process and what makes this self-healing process so revolutionary is that it uses moisture to transform and expand the crystals it into the surface pores. This will also prevent hairline cracks from opening or expanding. FLOAT tiles require very little maintenance and can be sprayed with a invisible water repellent for extra protection. As additional protection against environmental influences our tiles are sealed with a invisible silicone coating.



Our **concrete** is made of **38% waste by-product** and recycled materials.

Green concrete

The world needs concrete! so it's up to us as concrete producers to do what we can where we can to minimize our impact.

The industry already repurposes industrial byproducts that would otherwise be considered waste (fly ash, slag, and silica fume). When these materials were introduced a few decades ago, they were met with healthy skepticism but over time we came to realize that we could use these materials to save money, reduce emissions, and make better concrete. As an industry we always need to embrace innovation to create a stronger product and reduce our impact on the environment. It's the right thing to do and it makes sense, that's the type of logic that drives our industry.

01 Zero waste green concrete

Our concrete is designed to be better for the environment and your budget while also improving the performance characteristics of our product. The concrete mixture uses a high percentage of recycled materials.

FLOAT aims to reduce or avoid consumer waste by replacing certain raw materials with recycled glassfibre reinforced concrete. Currently around 38% of our product consists of recycled material and waste by-products. The biggest impetus for continuous development is the demand to create more than just sustainable concrete products in order to make an active contribution to the energy revolution.

02 Sustainability

The ecological idea behind concrete is consistently implemented in the manufacturing of our tiles. The production of FLOAT tiles require a low amount of primary energy, which in turn minimizes CO2 emissions and the greenhouse effect. Our product consists of purely mineral raw materials and is therefore completely recyclable. FLOAT pursues a holistic approach that covers the entire range of sustainability and meets the high demands of ambitious modern architecture.





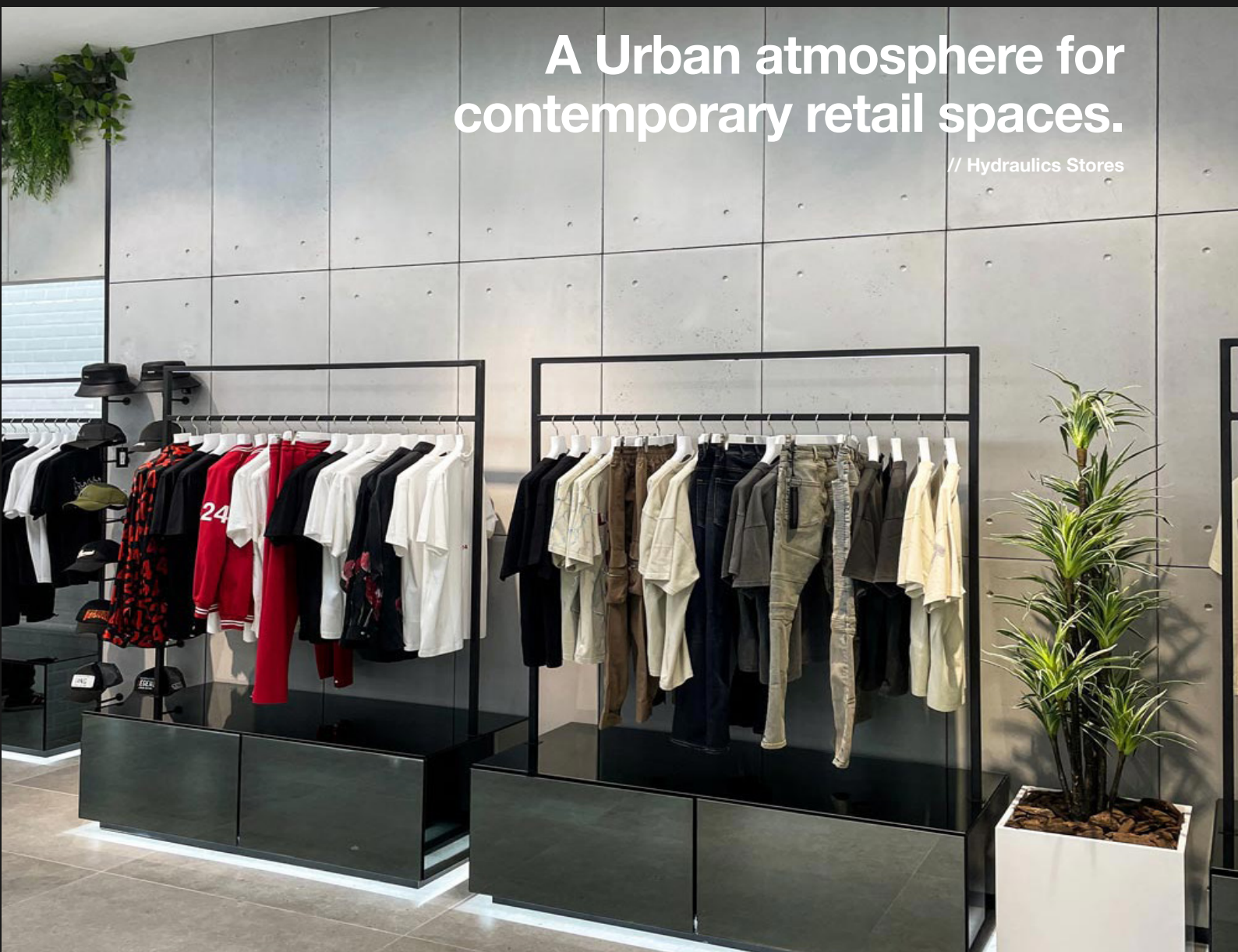

A Urban atmosphere for
contemporary retail spaces.

// Hydraulics Stores

Corner Solutions

Butt joint // Widely used corner detail due to simplicity, ease of installation and saves time on site. Generally the joints are on the side walls or walls facing away from the main view.

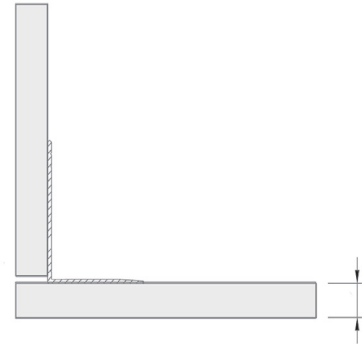

Mitre joint // This joint gives the corners a neat and pleasing detailed finish. The 45 degree angle can be cut with a diamond blade mitre saw. For best results cut approx 3mm from the corner to avoid chipping on sharp edge. First do a test piece to confirm desired guide line.

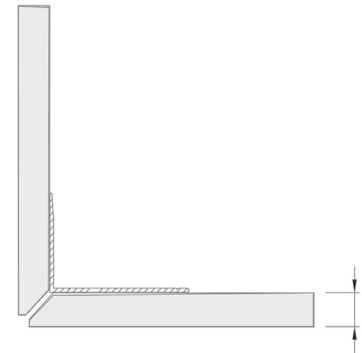

Square corner profile // This corner detail is most common when corners are visible and in traffic areas. First install the corner profile in place and fit tiles to fit. There are various types and finishes on the market. The colour of the tile can be matched or it can be used as a feature

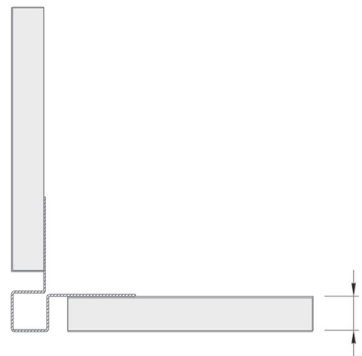

Handling + Maintenance

FLOAT tiles must be handled with love and care. Tiles must not rub or scratch against one another. When handling the tiles, never put it face down. Always place tiles on foam or styrene to prevent edges from chipping and damage.

Our tiles requires minimal maintenance with its long-term stability. On exterior applications It is advisable to spray tiles with a good-quality invisible water repellent every 4-5 years. There are various options on the market.



Installation

Fastening methods

There are various fastening methods - tile cement, polyurethane/polymer glues as well as mechanical fixing with some anchor hole models. We recommend always using good quality glues and tile adhesives with slightly faster drying times. Here is a few invisible and exposed fastening options. You can refer to our install guide or contact us.

01 Cementitious adhesive fixing

This method is widely used and also most cost effective. The same principles here applies for any other professional tiling project and can be installed by any qualified tiling professional. We recommend using good quality products and tile cement with slightly faster drying times is a advantage.

For more in-depth information please contact us for our **installation guide**. All the info supplied in this guide should be standard practice for most tiling projects.

During manufacturing FLOAT tiles are made with a textured, coarse silica layer added to the rear surface to ensure beter adhesion and grip to the tile adhesive. Always ensure the surface is clear of any loose particles before installation.

02 Substrate screw fixing (Anchor hole tiles)

We recommend using this method at heights and verticals where there is foot traffic. Double sided tape can be used as spacers where the plugs are, this will also waterproof the area. For exterior applications where health and safety is a concern you can add fischer plugs and screws to fasten the tiles to the masonry substrate. We recommend using a 5/6 x 60-80mm plugs with matching screws. Drill a hole in the centre of the anchor hole and fasten until level. We can supply plastic screw cover caps for a more aesthetically pleasing look. This is easy to apply and a cost effective safety solution.

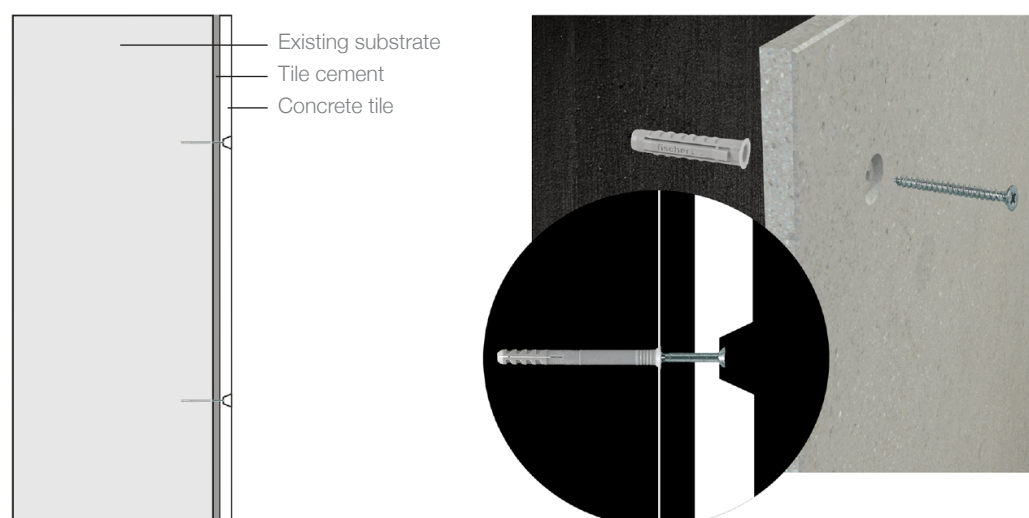

03 Subframe + riveting

The tiles can be fastened with rivets on a metal substructure. The substructure will consist preferably of vertical profiles, fitted using wall bracket holders to the wall. The substructure must be adjustable to balance out any building tolerances and facilitate smooth fitting. The substructure can also be custom made with mostly vertical sleeves and anchors made from various metals. FLOAT supplies the tiles only, entire subframe system and rivets must be supplied by preferred supplier.

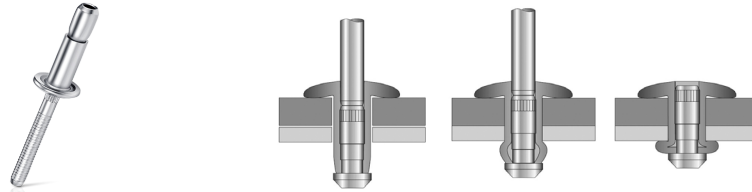

Tile Subframing system that offers visible rivet fixing for concrete tiles. The rivet attachment guarantees high pull-out values and ease of installation. Engineered to address deadload, windload, seismic concerns, thermal requirements and material deflection for either steel stud or concrete back-up conditions. Rivet holes on the tiles can be drilled using a drill jig. Hole size dependent on rivet size. Holes in the substructure must be drilled using a centre sleeve to ensure the bore hole is

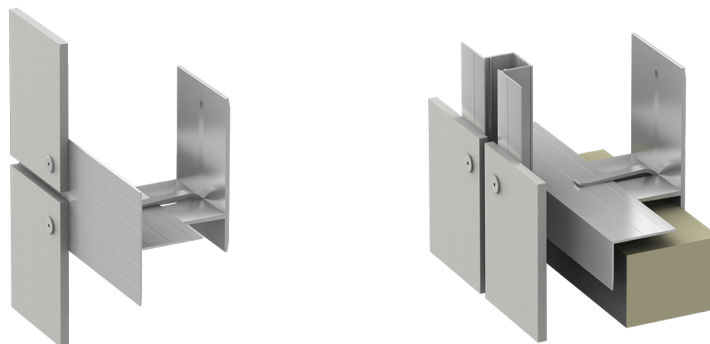
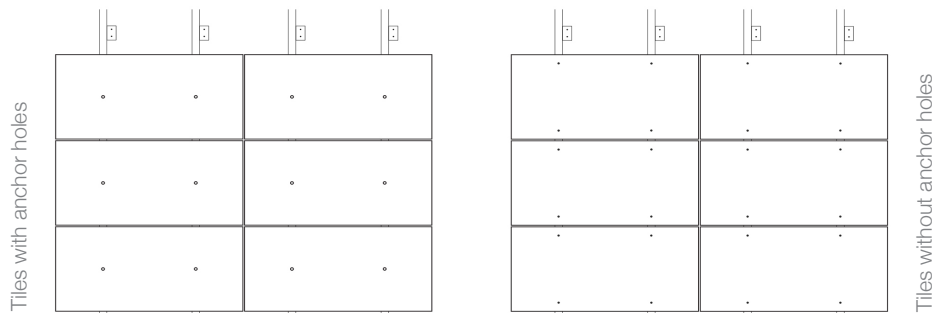

Recommended rivets with special colours matching FLOAT surfaces are available from different fastener manufacturers. Indicate the standard FLOAT colour used and the manufacturer will give you a matching recommendation for the rivet colour.

04 Subframe + concealed anchor

Panel Subframing system that offers fixing using concealed undercut anchors for FLOAT concrete tiles using a edge to edge wall bracket. The back of each tile is pre-drilled using an undercut drill bit to receive the hanger clip and expanding bolt anchor. Engineered to address dead load, wind load, seismic concerns, thermal requirements and material deflection for either steel stud or concrete back-up conditions. FLOAT supplies the tiles only, entire subframe system and rivets must be supplied by preferred supplier. Contact us if you need more information.

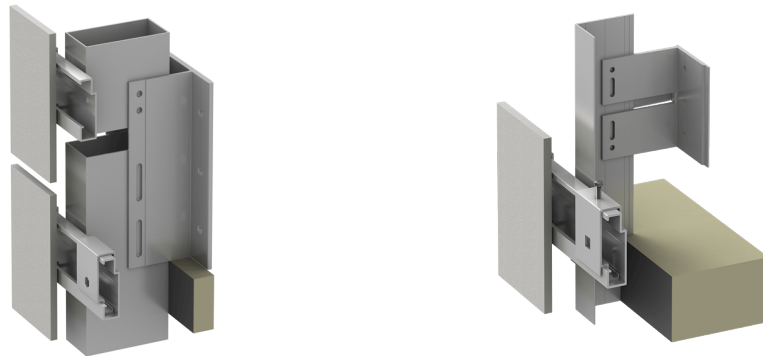

Tiles with a thickness of 14 mm can be fitted invisible on the back with metal clips and special dowels. For this purpose, each panel has on the top row of clips adjusting screws and a fixed point fastening (screw or clip), with the result that it can be aligned and no displacement occurs.

With undercut anchors and clips suspended in horizontal aluminium carrier profiles. Fasteners recommended in the system approval: Keil anchor with the marking Hs=8.5 mm or equivalent. Each tile must be attached with no technical force necessary, with at least four anchors in a rectangular arrangement via single brackets or double brackets. The dead load of the panels is removed with the top bracket line.

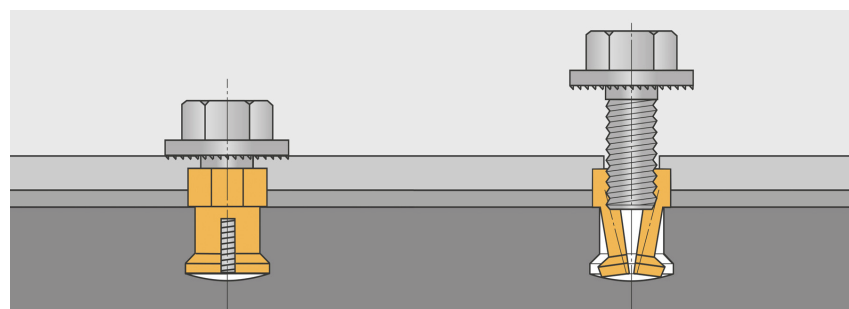

Note:

The information listed above is not part of the performance of FLOAT concrete. FLOAT produces KonkreteSeries tiles only and no fastening agents or substructures. Any liability for the substructure is excluded. The instructions given by the manufacturer of the substructure must be included in the detailed planning of the substructure. The possible types of fastening will vary depending on the particular construction project and the particular manufacturer is responsible for the fastening systems.



Become a reseller

With more than 18 years experience in the concrete manufacturing industry we expanded into many markets, however there are many white spots on the map worldwide and we know that our products are wanted everywhere. That's why we are looking for new partners all over the globe that can distribute our product in their country.

If you are interested to become our partner, **please refer to our Trade Loyalty Program for all details and information.**

Together for better architecture.

Architects + Designers

FLOAT has been working closely with numerous architects and designers over many years to make concrete a reality at economical prices while speeding up construction times. If you have any questions or need any info on our products for a project you are working on don't hesitate to get in touch with us to discuss.

Render to reality

The designers at FLOAT can support architects, planners and designers in the early planning phase of their projects. Architects, planners and designers are welcome to contact us for 3D models of our tiles. info@floatconcrete.com

Custom made

Depending on quantities needed custom tile sizes and special colours can be developed and manufactured on request. Contact us with your requirements to obtain pricing and details.

Shipping

Shipping rates vary depending on quantities and the desired destination. Contact us with your requirements to obtain up to date shipping rates.



Trade Loyalty Program

Our professionals trade program provides members of the design industry with exclusive discounts and special offers. This program rewards interior designers, architects, resellers and developers by offering a trade discount on our concrete products.

Join.
Collaborate.
Save.

Applying is effortless

To become our partner, send us the following information:

- Full Name
- Business Name
- Email
- Business website and instagram
- Business card
- Trade profession

Send all documentation to collab@floatconcrete.com and our team will get in touch with you to process your application.

Eligibility

All applicants who are accredited professionals will be eligible for participation in this Trade Loyalty Program upon approval by the our company FLOAT concrete Pty(Ltd)

Trade benefits

Once the Trade Account is approved our partner will receive a personalised discount code to be used for all purchases to qualify for the appropriate discount.
Our product sample pack will be available to our approved partners.

FLOAT
CONCRETE

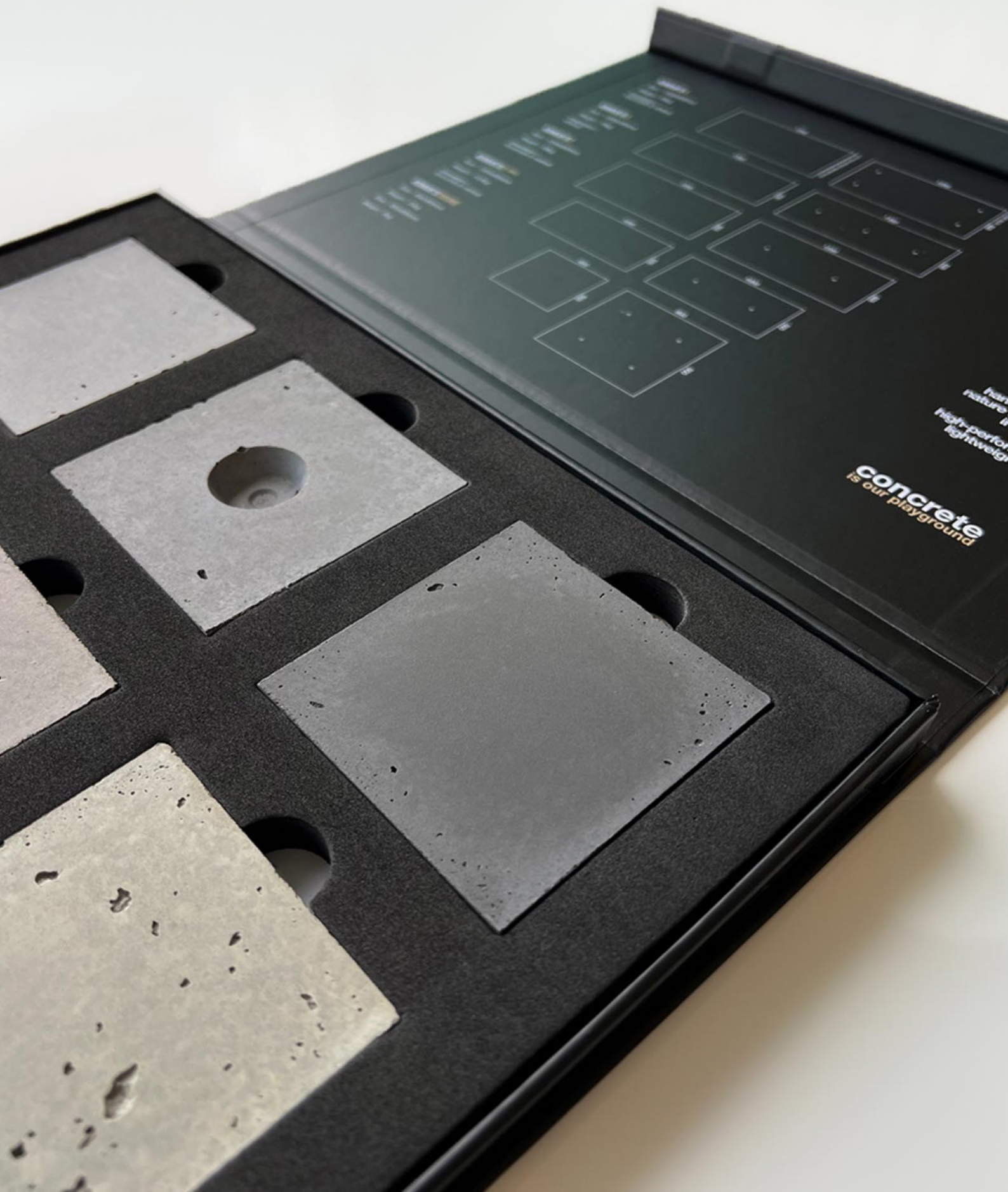

High-performance
lightweight

concrete
is our playground



Concrete is our playground.

Get in touch.

www.floatconcrete.com 

info@floatconcrete.com 

[float__concrete](#) 

[float design](#) 



FLOAT

