

MAGIS

Trave by BrogliatoTraverso



Brogliato Traverso



Profile:

After graduating in Architecture from Venice University, Italy and various experiences – from learning how to blow glass in Murano to working traditional ceramics in Japan – Alberto Brogliato and Federico Traverso founded BrogliatoTraverso design studio in 2014. Their approach to design is called 'NO TIME, NO SPACE' and refers to their will to make objects with a timeless design that fits any context.

BrogliatoTraverso work by subtracting, creating a detailed sign, but almost invisible. With these finely hinted forms,

their creations establish deep intimate empathy with the users and their surroundings, respecting both of them. Their fine simplification process delivers projects addressing the needs of consumers and made for various companies, including Magis, Cappellini, Guzzini, Infiniti, Il Fanale/Torremato and more.

These partnerships have won the studio many international awards, including ADI Index, the Red Dot Design Award, German Design Award, iF Design Award and Good Design Award.



Design and

A new perspective on the chair, a complexity resolved with simple and distinctive style. Trave, the new chair designed by Alberto Brogliato and Federico Traverso, is a response to the challenge set out by Magis: a new take on the concept of solid wood.

What BrogliatoTraverso came up with is all about subtraction: a simple bar of solid ash which becomes the focus of the entire design. The steam-bent bar is the only element to which the legs and the two fabric cushions, which serve as seat and backrest, are attached. This innovative structural solution reduces the components to a minimum, while increasing comfort by allowing large padded surfaces.

“No time, no space” is the slogan of the BrogliatoTraverso design approach, almost imperceptible in its sophistication, with an inconspicuous elegance and a poetic and inviting allure. Just like Trave, a chair suitable for any setting, whether domestic or contract: almost archetypal, yet graceful and timeless. Effortless furniture which is unconstrained by trends and which reflects the multi-faceted nature of modern living.

The frame is available in three colours, natural ash, black ash, and oak finish, while the cushions are available in a variety of fabrics suitable for both home and contract settings.



Engineering



“Trave presents a new perspective on the structure of a solid wood chair, a



complexity resolved with simple and distinctive style”.

Brogliato Traverso



Information



Product

Steam-bent bar and legs in solid ash, natural, stained black or oak finish.
Upholstered seat and back covered in removable fabric.



Seat and legs in solid ash /	Cushions /
Natural or stained black	Fabric cat.1
Oak finish	Fabric cat.1
Natural or stained black	Fabric cat.2
Oak finish	Fabric cat.2
Natural or stained black	Fabric cat.3
Oak finish	Fabric cat.3

Materials /

Legs in solid ash /

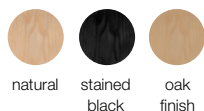

natural stained black oak finish

Fabric cat.1 /

Fidivi Torino

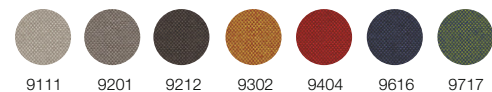

Fabric cat.2 /

Kvadrat Reflect

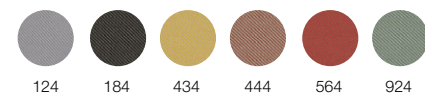

Fabric cat.3 /

Torri Lana Parallel

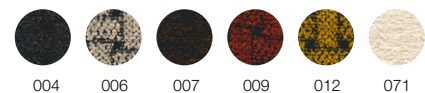

Rubelli Spritz

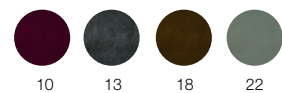

Rubelli Fabthirty

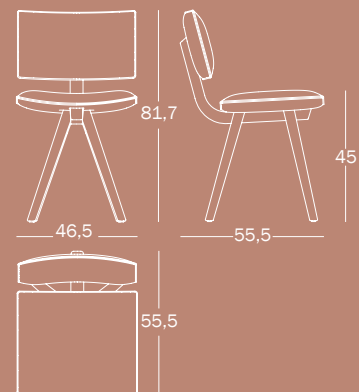
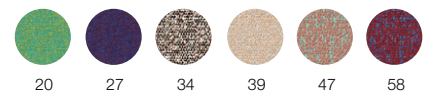

PRODUCT CARE

We recommend using a soft, either dry or wet, rag. When needed, use ph-balanced liquid soap especially formulated for wood, diluted in water. Do not use abrasive sponges as they may leave scratches. Avoid using acidic products, solvents, and products containing ammonia. Daily care and immediate stain removal for the fabric will ensure that your upholstery will keep looking good. It is normally sufficient to regularly vacuum and air upholstered cushion. We suggest cleaning the fabric occasionally. Use a specific fabric cleaning soap and follow the instructions carefully. Take care never to saturate the fabric. Never use undiluted cleaning agents, bleaching agents, ammonia or soap intended for hard surfaces. As a general rule, many types of stains can be removed using lukewarm water. For greasy stains, use a dry stain remover. For more insoluble stains (chewing gum, candle wax, etc.), use a plastic bag filled with ice to rub the stain until the substance has become friable. Use a clean flat blunt blade to delicately remove the substance. Be careful when using solvents because these could dissolve the upholstery material beneath. Avoid exposure to sunlight. Periodic and correct maintenance allows the product to keep its original aspect and lengthen the duration of its performance.

WARNING

Do not use different cleaning products from the ones mentioned above. Do not use the product in an improper way. Do not place hot objects on it, sit on the back, stand on it or use the product as a ladder. Once disused, please make sure that this product is disposed in an environment-friendly way.



