



materia infinita[®]

LAYING INSTRUCTIONS

REV_09/23



CLADDING WITH NOVOWOOD SYSTEM

LIST OF MATERIALS TO BE USED



SKIN PRESTIGE 145 STAVES

145x22x2200 mm
 (~ 5 1/16 in x 7/8 in x 7 ft 2 5/8 in)
 cod. 145H22

AVERAGE USE 3,15 pcs/m2 (~0,29 pcs/sq ft)



SKIN PRESTIGE 197 STAVES

197x22x2200 mm
 (~ 7 3/4 in x 7/8 in x 7 ft 2 5/8 in)
 cod. 197H22

AVERAGE USE 2,30 pcs/m2 (~0,21 pcs/sq ft)

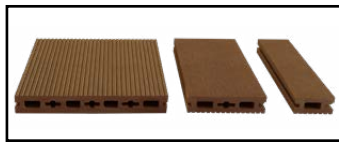

SKIN PRO STAVES

197/97/47x22x2900 mm
 cod. 197H22P

(~ 7 3/4 in / 3 13/16 in / x 1 7/8 in x 7/8 in x 9 ft)
 AVERAGE USE 2,30 pcs/m2 (0,21 pcs/sqft) (profile 197)



SKIN MAX STAVES

250x20x2900 mm
 (~ 9 13/16 in x 1 1/16 in x 9 ft 6 3/16 in)
 cod. 250H20

AVERAGE USE 1,38 pcs/m2 (~ 0,13 pcs / sq ft)



SKIN STAVES

127x15x2000/4000 mm
 (~ 5 in x 5/8 in x 9 ft / 13 ft 1 1/2 in)
 cod. 127H15

AVERAGE USE 3,93 pcs/m2 (L=2000)

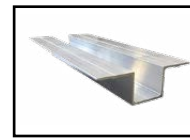

OMEGA WALL PROFILE

cod. 90H25
 AVERAGE USE 3,00 m/m2
 (~ 11 in / sq ft)



STEEL CLIPS + SCREW

cod. CLIPS-V-5.5
 cod. CLIPSHP9
 cod. CLIPS-A-5



SKIN CLIPS + SCREW

cod. CLIPSHP7



STARTER CLIPS + SCREW

(OPTIONAL)
 cod. IF



NOVOSTRIP



FIXINGS

IMPORTANT NOTES

CORRECT USE OF THE MATERIAL

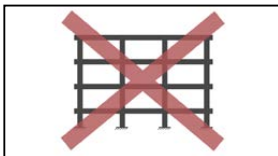

Novowood products are covering materials that, despite their mechanical strength characteristics, must always be laid on a supporting substructure of a suitable size.

THERMAL EXPANSION

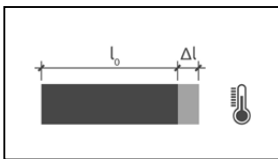

Wood plastic composite is subject to slight thermal expansion due to the presence of a small amount of HDPE plastic in its mix. The expansion index defined in the data sheet is equal to **0.04 mm/m/°C**. It is therefore recommended to calculate the grouting between the staves heads according to external temperatures during laying and to the annual thermal variation forecast.

VENTILATION AND AIRSPACE

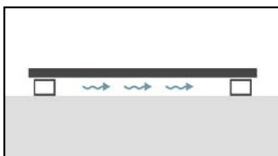

It is essential to ALWAYS leave an airspace between the slats and the supporting surface to allow ventilation. This is usually done by using subconstruction framework joists.

FIXINGS

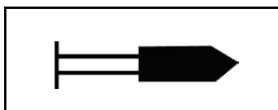

It is necessary to evaluate the fixing system which is more suitable according to the typology of substrate and the loads.

HUE VARIATIONS OF DIFFERENT LOTS

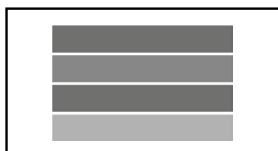

Novowood is a wood plastic composite produced by extrusion, therefore it is possible to have little hue variations between different lots produced. It is advisable to lay the material picking up staves from different pallets.

STEP BY STEP CLADDING INSTALLATION GUIDE

1 SUBCONSTRUCTION FRAMEWORK JOISTS

Subconstruction framework aluminium joists must be laid respecting all the distances necessary to support the whole covering system.

Make sure to reduce any irregularities on the wall in order to obtain a flat surface.

The section sizing of the subconstruction framework joists must be verified by a qualified technician on the basis of the specific project.

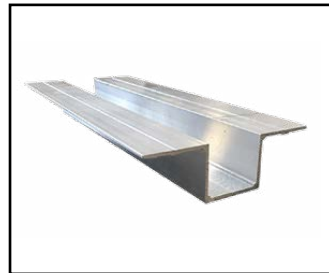

Subconstruction framework aluminium joists

1.1 Laying the joists

1 HOLES ON JOISTS

Drill the aluminium bars indicatively every 1000 / 1500 mm (~ 3 ft 3 3/8 in / 4 ft 11 in).

It is necessary to practise the holes evaluating the possible thermal expansion of aluminium.



The right distance must still be verified by a qualified technician depending on the load to be maintained and the type of bearing wall.

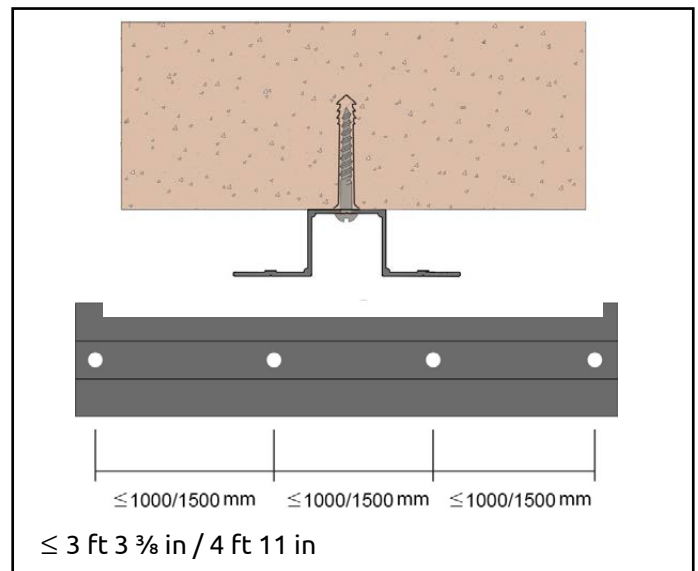

2 POSITIONING JOISTS ON A WALL

Fix the joists to the wall while maintaining a maximum distance of 500 mm (~ 1 ft 7 1/16 in).

Place the joists in correspondence with the heads of the staves as indicated in step 7 of the third chapter (staves).



The right distance will still be verified by a qualified technician depending on the load to be maintained and the typology of bearing wall.

In case of installation of the staves vertically, in order to obtain linear grouts, it is recommended to insert an angular profile on the inferior level of the façade and of the openings (doors/windows), of a dimension which does not obstruct the holes of the Novowood profiles.

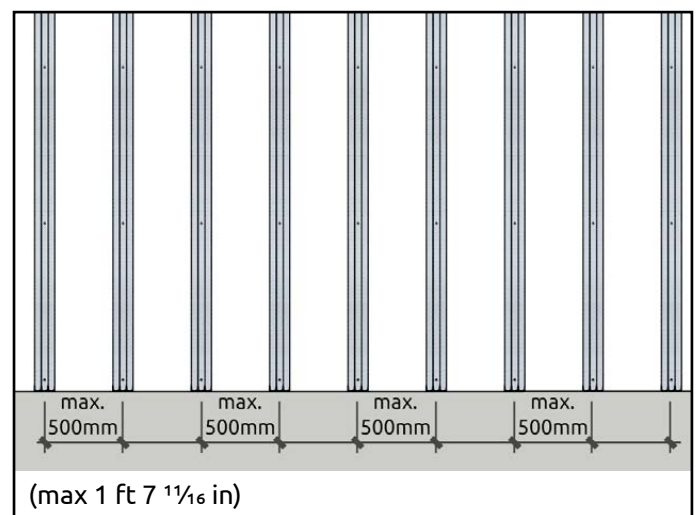

3 POSITIONING JOISTS NEXT TO THE EDGE OF THE WALL

Make sure to do NOT leave a space bigger than 50 mm (~ 2 in) when you are going to lay the joists near the edge of the wall.

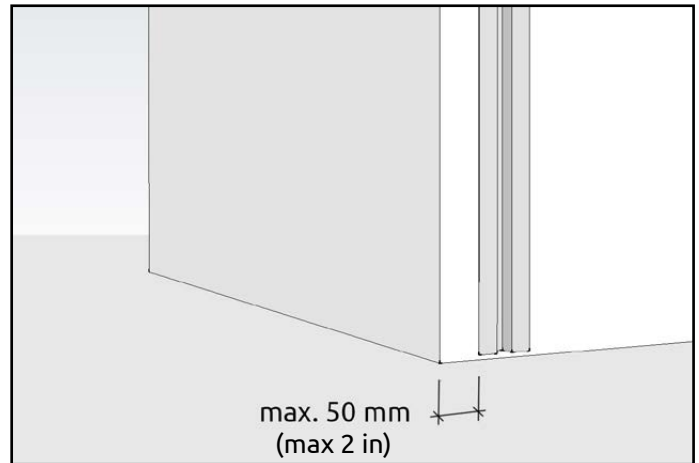

4 JOISTS POSITIONING IN CASE OF DOORS AND WINDOWS

If there are any doors and / or windows on a wall, fix the currents beside them, as shown in the figure, leaving a maximum space of 50 mm (~ 2 in) from the edge.

For the closure of intrados and openings it is advisable to use tinsmithery, to be laid after the cladding.

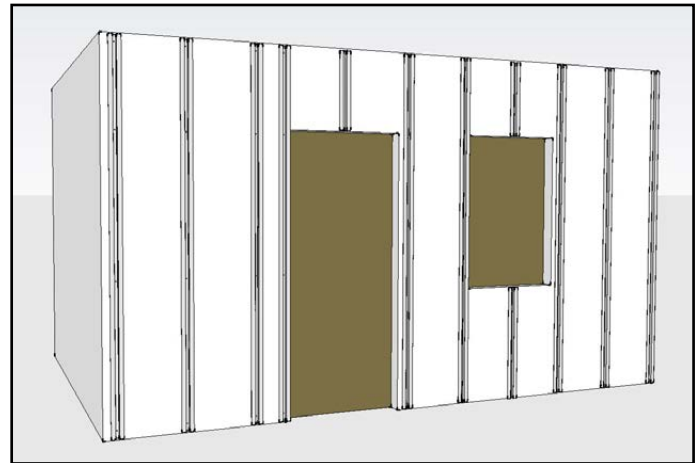

2 NOVOSTRIP

Novostrip is a special butyl tape to be applied between the joist and the stave to reduce their longitudinal slippage. It is installed by applying a 10 cm (~ 3 15/16 in) strip on the joist closest to the middle section of the stave, as shown in the picture.

Remember that it must be applied on every stave in the cladding.

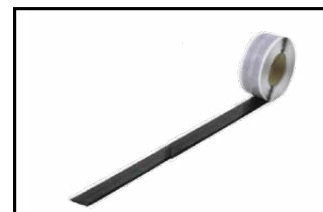

Novostrip

-  NOVOSTRIP tape
-  Highlighted staves

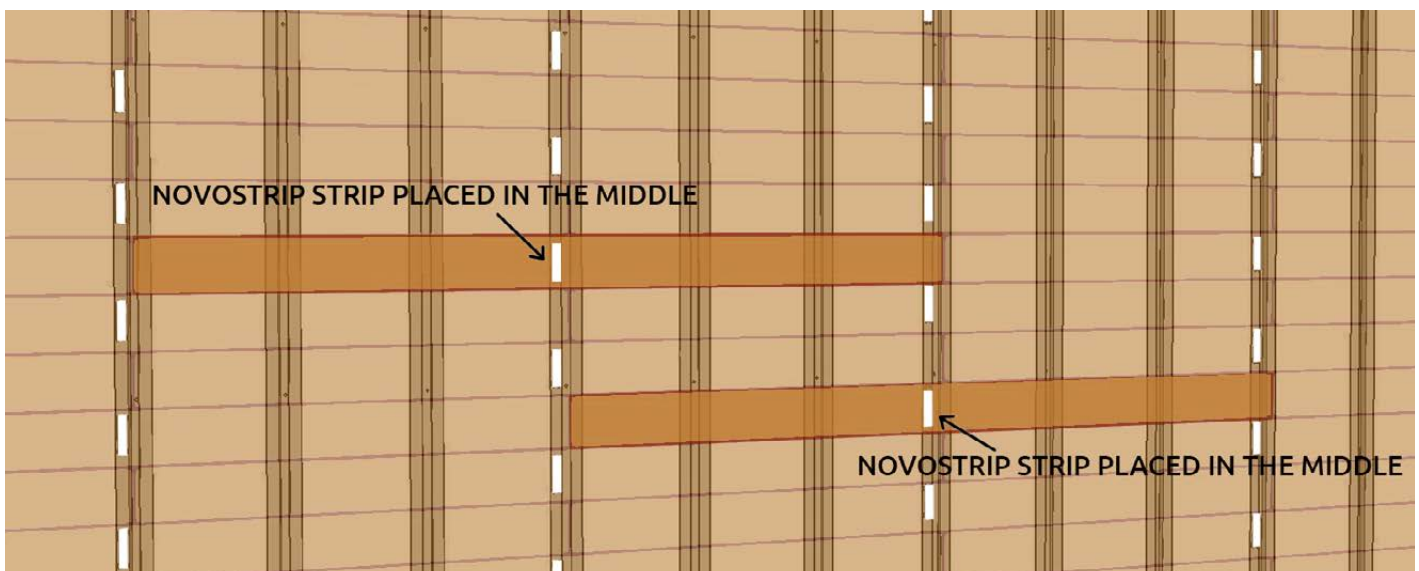

3.a LAYING THE SKIN PRESTIGE 145 145x22 mm AND SKIN PRESTIGE 197 197X22 mm STAVES

Skin Prestige staves can be laid on either side, depending on the design choice.



CAUTION

Wood plastic composite is subject to slight thermal expansion (0.04 mm/m/°C). Ensure that recommended distances are observed.

SUITABLE CLIPS:



Steel clips
3/4 mm
(~ 1/8 in)

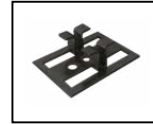

Steel clips
5 mm
(~ 3/16 in)



Steel clips
7/8 mm
(~ 5/16 in)



Starter clips

1 STAVE DISTANCE FROM THE GROUND

(STAVES 145X22 AND 197X22)

It is necessary to leave a space between the first stave and the ground of **at least 10 mm (~ 7/16 in)**, to allow the material ventilation.

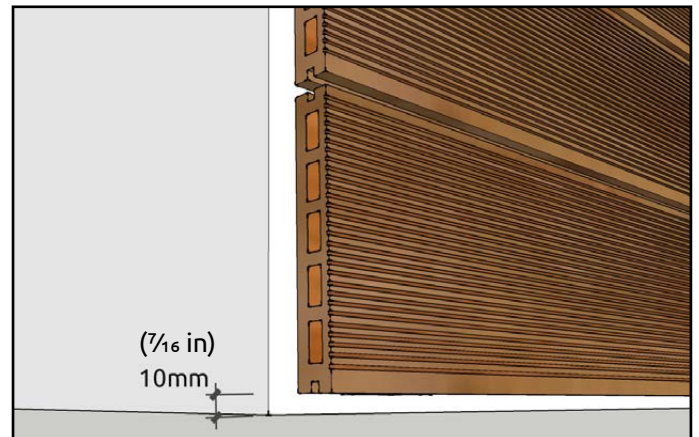

2 STARTER CLIPS POSITIONING

Place the starter clips on the joists and screw them.



CAUTION

Check the squaring by positioning a stave before final clip fixing.

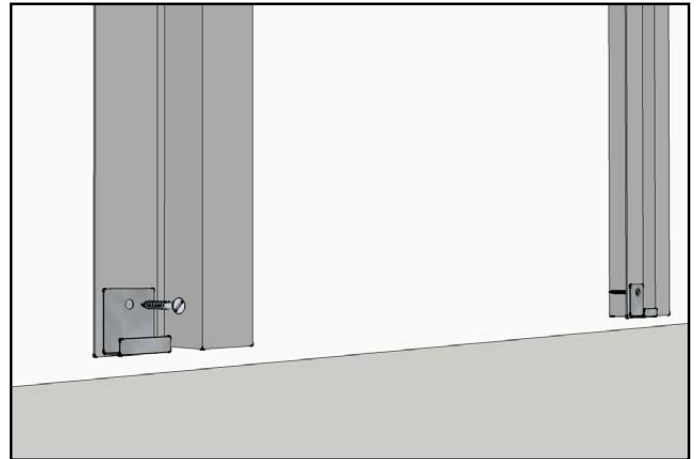

3 FIRST STAVE POSITIONING

Position the first stave and insert it into the screwed in clips.



CAUTION

Pay particular attention to the orientation of this stave as all the subsequent ones will follow the same direction.



4 CLIP POSITIONING

Position the entire row of clips, screwing them into the joists, as shown in picture.

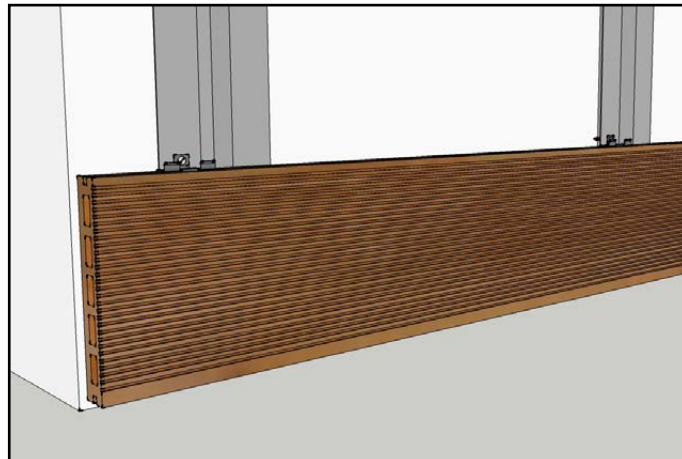

5 SECOND STAVE POSITIONING

Position the second stave, placing it onto the row of clips which have just been installed, and then block it applying a new row of clips above.

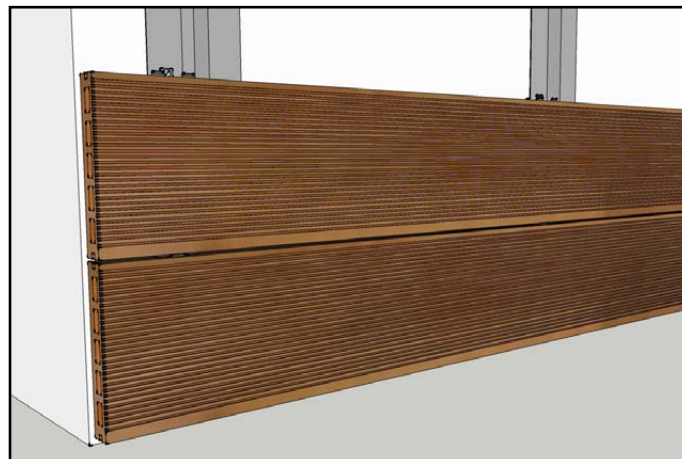

6 COMPLETING INSTALLATION

Repeat steps 4 and 5 until the area to be covered is complete.



7 POSITIONING ADJACENT STAVES

Leave a space of about **3 mm (~ 1/18 in)** between two adjacent staves to allow the natural thermal expansion of the wood plastic composite. The distance must be evaluated depending on the temperature at moment of the installation and annual climate variations, considering that the solar radiation sensibly modifies the temperature of the material.

- Laying at **10°C (50 °F)**= distance **4 mm (~ 3/16 in)** for staves with a length of 2,200 mm (~ 7ft 2 5/8 in).
- Laying at **20°C (68 °F)** = distance **2 mm (~ 1/16 in)** for staves with a length of 2,200 mm (~ 7ft 2 5/8 in).
- Laying at **t_{max}** = distance **0 mm (~ 0 in)** for staves with a length of 2,200 mm (~ 7ft 2 5/8 in).



CAUTION

The 2 adjacent staves will stick to the same omega joist with 2 clips.

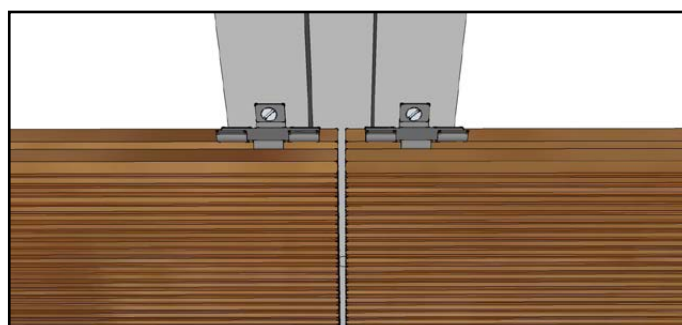
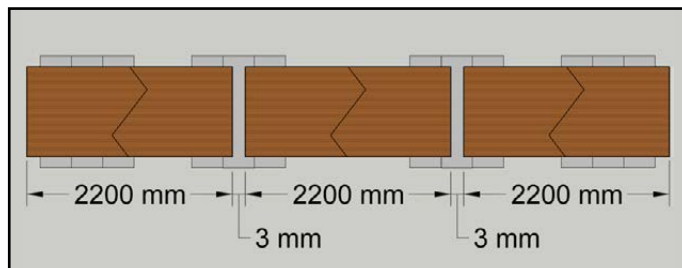

8 POSITIONING STAVES NEXT TO THE EDGE OF THE WALL

Lay the staves in the corner of a wall as shown in the figure. A stave will have a greater boss, up to the outside thread of the perpendicular stave.

To cover the hollow we recommend using a L-shaped profile or using a special aluminium profile.

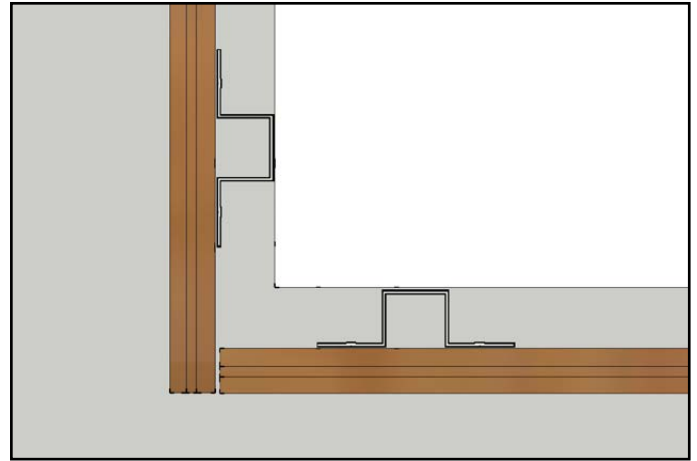

9 STAVES POSITIONING ON THE UPPER EDGE

9.1 Wall with fixed height

Cut a stave close to a hole, creating a smooth finish.

Create a hole on the stave larger than the diameter of the screw of 3 mm (~1/8 in); this passage is essential to allow the natural expansion of the material.

It is recommended to cover everything with a Corner Novowood composite wood profile or metallic skirt.

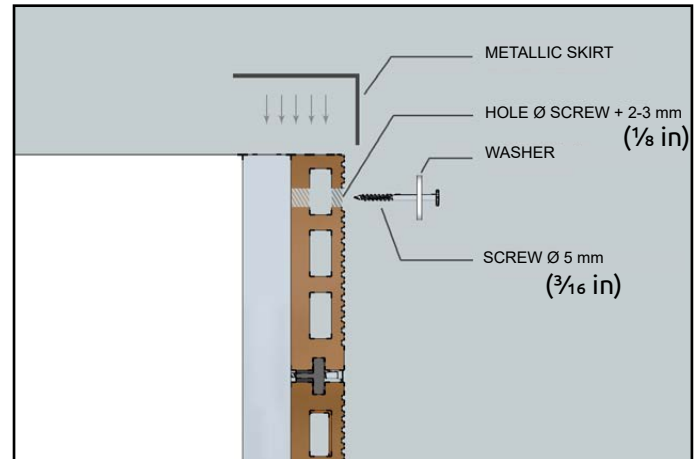

3.b LAYING THE SKIN PRO STAVES 197/97/47x22 mm

Skin Pro staves can be laid on either side, depending on the design choice.



CAUTION

Wood plastic composite is subject to slight thermal expansion (0.04 mm/m/°C). Ensure that recommended distances are observed.

SUITABLE CLIPS:



Steel clips
5 mm
(~ 3/16 in)



Steel clips
7/8 mm
(~ 5/16 in)



Starter clips

1 STAVE DISTANCE FROM THE GROUND (STAVES 197/97/47X22)

It is necessary to leave a space between the first stave and the ground of **at least 10 mm (~ 7/16 in)**, to allow the material ventilation.

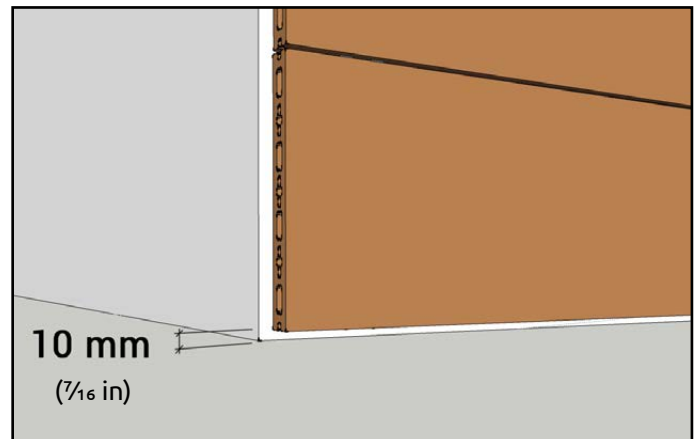

2 STARTER CLIPS POSITIONING

Place the starter clips on the joists and screw them.



CAUTION

Check the squaring by positioning a stave before final clip fixing.

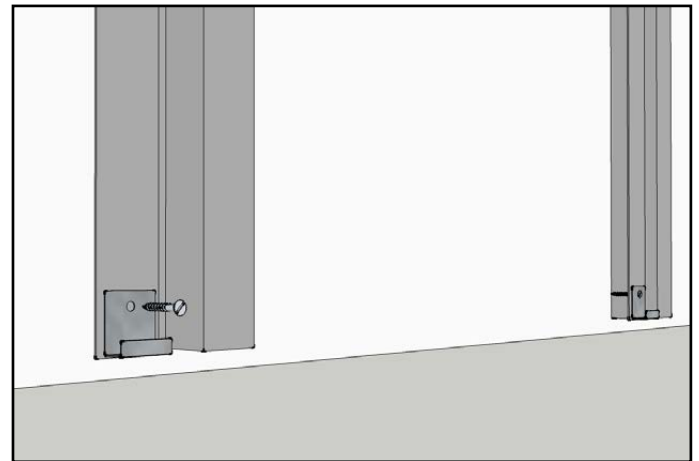

3 FIRST STAVE POSITIONING

Position the first stave and insert it into the screwed in clips.



CAUTION

Pay particular attention to the orientation of this stave as all the subsequent ones will follow the same direction.

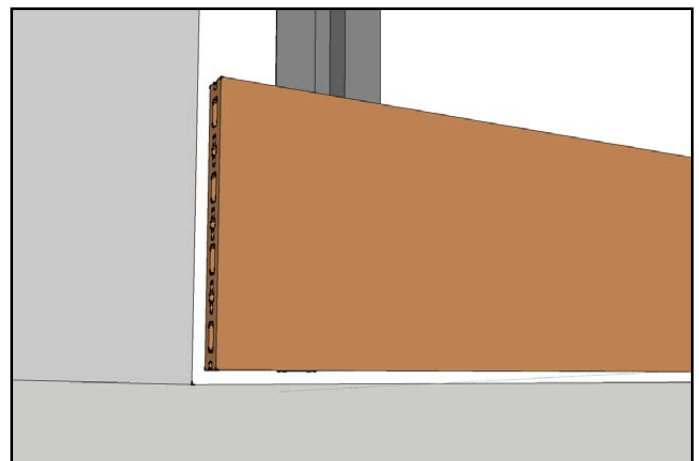

4 CLIP POSITIONING

Position the entire row of clips, screwing them into the joists, as shown in picture.

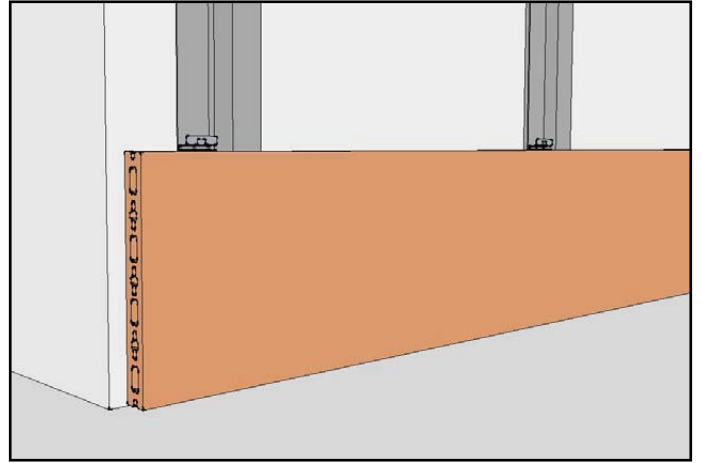

5 SECOND STAVE POSITIONING

Position the second stave, placing it onto the row of clips which have just been installed, and then block it applying a new row of clips above.

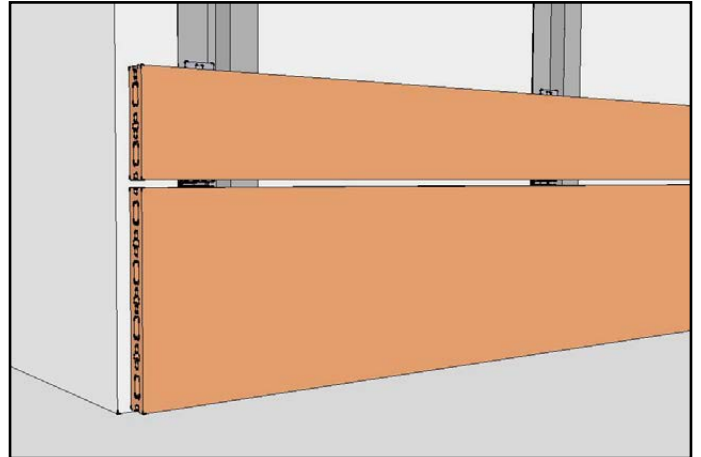

6 COMPLETING INSTALLATION

Repeat steps 4 and 5 until the area to be covered is complete.



7 POSITIONING ADJACENT STAVES

Leave a space of about **5 mm (~ 2 in)** between two adjacent staves to allow the natural thermal expansion of the wood plastic composite. The distance must be evaluated depending on the temperature at moment of the installation and annual climate variations, considering that the solar radiation sensibly modifies the temperature of the material.

- Laying at **10°C (50°F)** = distance **6 mm (~ ¼ in)** for staves with a length of 2,900 mm (~9 ft 6 ¾ in).
- Laying at **20°C (68°F)** = distance **3 mm (~ ⅛ in)** for staves with a length of 2,900 mm (~9 ft 6 ¾ in).
- Laying at **t_{max}** = distance **0 mm (~ 0 in)** for staves with a length of 2,900 mm (~9 ft 6 ¾ in).

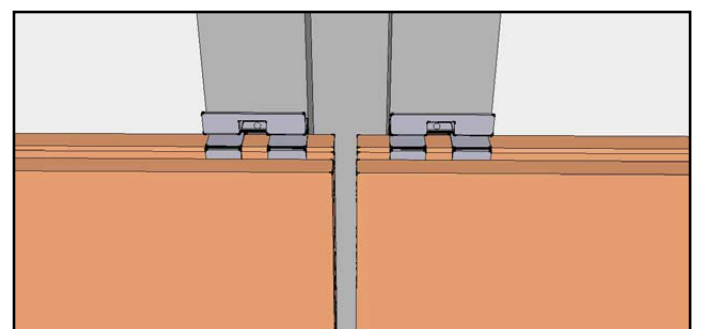
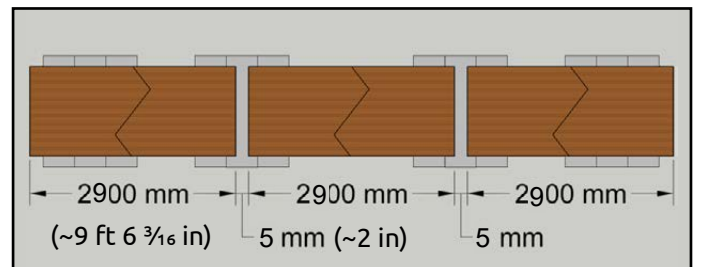

CAUTION

The 2 adjacent staves will stick to the same omega joist with 2 clips.

8 POSITIONING STAVES NEXT TO THE EDGE OF THE WALL

Lay the staves in the corner of a wall as shown in the figure. A stave will have a greater boss, up to the outside thread of the perpendicular stave.

To cover the hollow we recommend using a L-shaped profile or using a special aluminium profile.

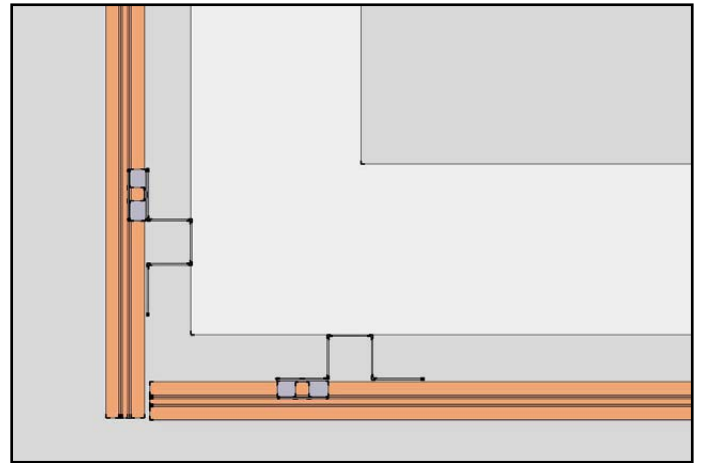

9 STAVES POSITIONING ON THE UPPER EDGE

9.1 Wall with fixed height

Cut a stave close to a hole, creating a smooth finish.

Create a hole on the stave larger than the diameter of the screw of 3 mm (~1/8 in); this passage is essential to allow the natural expansion of the material.

It is recommended to cover everything with a Corner Novowood composite wood profile or metallic skirt.

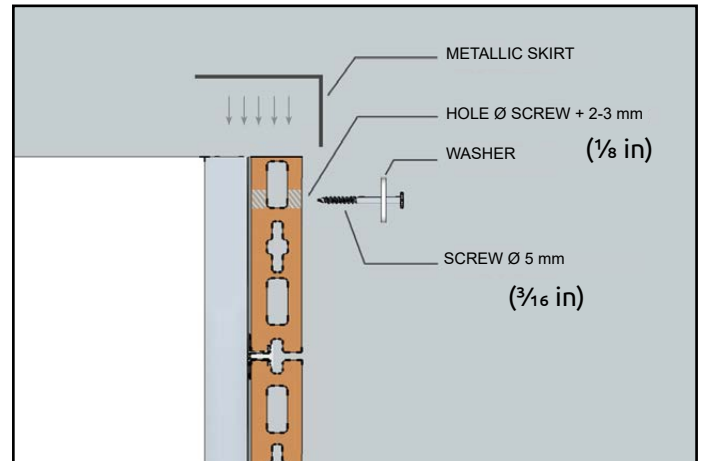

3.c LAYING THE SKIN MAX STAVES 250x20 mm (~ 9 13/16 in x 13/16 in)

Skin Max staves can be laid on either side, depending on the design choice.



CAUTION

Wood plastic composite is subject to slight thermal expansion (0.04 mm/m/°C). Ensure that recommended distances are observed.

SUITABLE CLIPS:

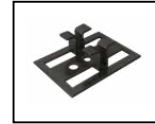

Steel clips
5 mm
(~3/16 in)



Starter Clips

1 STAVE DISTANCE FROM THE GROUND (STAVES 250X20)

It is necessary to leave a space between the first stave and the ground of **at least 10 mm** (~ 7/16 in), to allow the material ventilation.

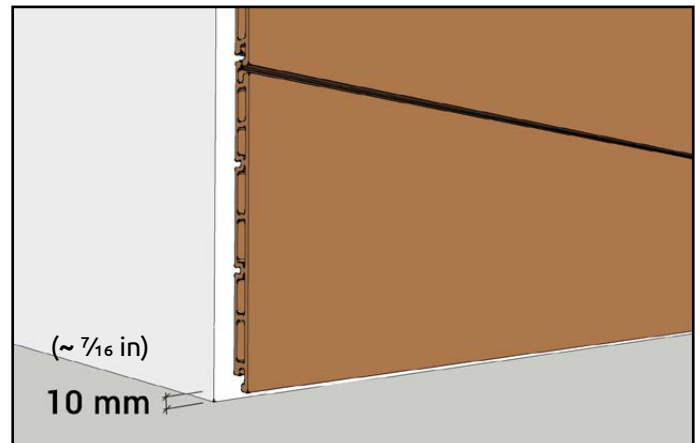

2 STARTER CLIPS POSITIONING

Place the starter clips on the joists and screw them.



CAUTION

Check the squaring by positioning a stave before final clip fixing.

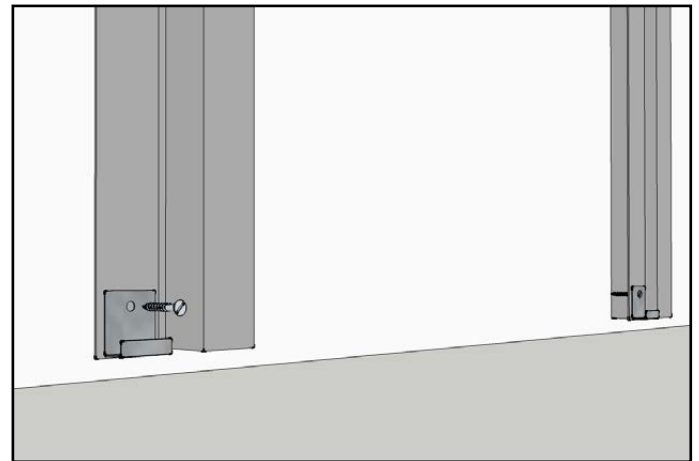

3 FIRST STAVE POSITIONING

Position the first stave and insert it into the screwed in clips.



CAUTION

Pay particular attention to the orientation of this stave as all the subsequent ones will follow the same direction.

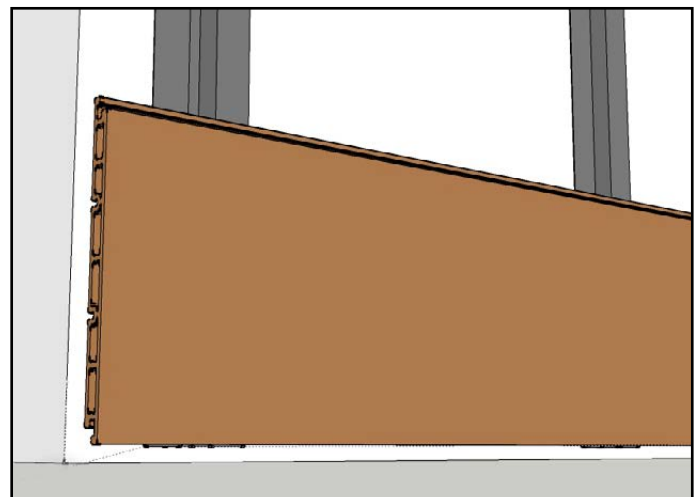

4 CLIP POSITIONING

Position the entire row of clips, screwing them into the joists, as shown in picture.

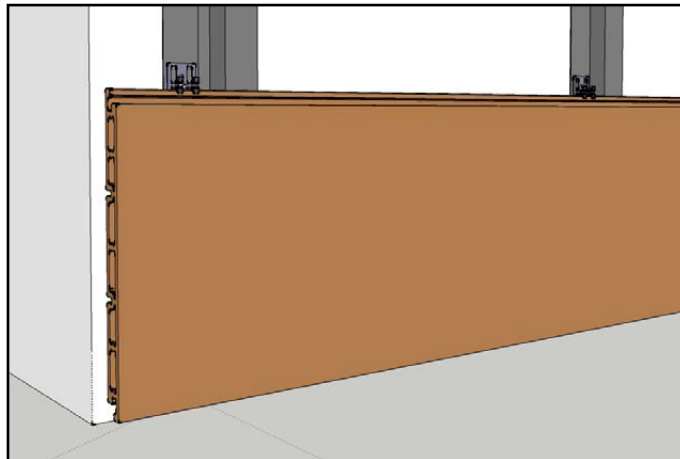

5 SECOND STAVE POSITIONING

Position the second stave, placing it onto the row of clips which have just been installed, and then block it applying a new row of clips above.

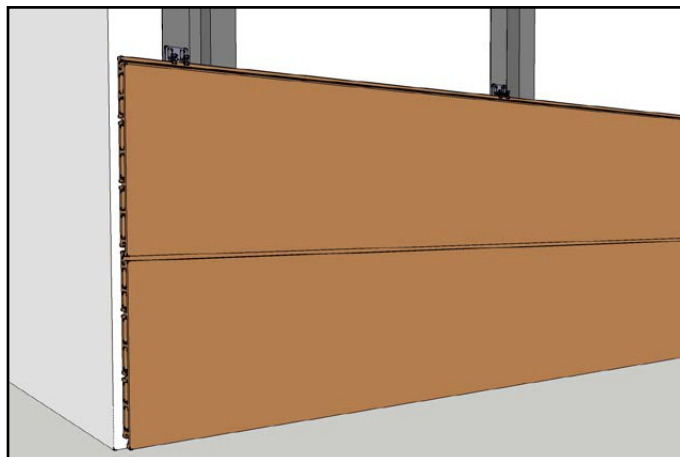

6 COMPLETING INSTALLATION

Repeat steps 4 and 5 until the area to be covered is complete.

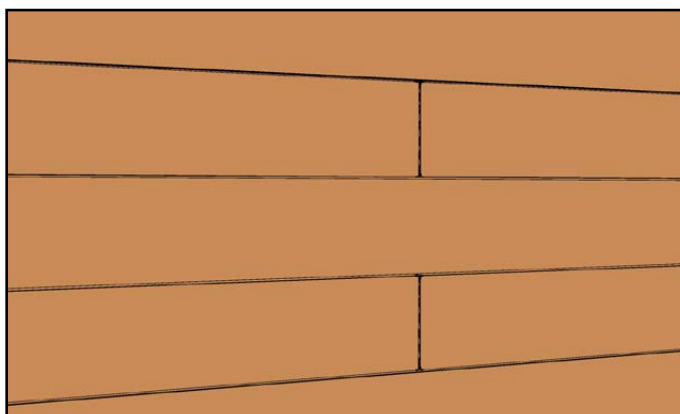

7 POSITIONING ADJACENT STAVES

Leave a space of about **5 mm (~ 2 in)** between two adjacent staves to allow the natural thermal expansion of the wood plastic composite. The distance must be evaluated depending on the temperature at moment of the installation and annual climate variations, considering that the solar radiation sensibly modifies the temperature of the material.

- Laying at **10°C (50°F)** = distance **6 mm (~ ¼ in)** for staves with a length of 2,900 mm (~9 ft 6 ¾ in).

- Laying at **20°C (68°F)** = distance **3 mm (~ ⅛ in)** for staves with a length of 2,900 mm (~9 ft 6 ¾ in).

- Laying at **t_{max}** = distance **0 mm (~ 0 in)** for staves with a length of 2,900 mm (~9 ft 6 ¾ in).



CAUTION

The 2 adjacent staves will stick to the same omega joist with 2 clips.

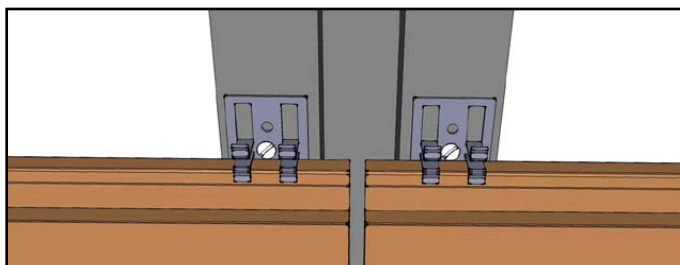
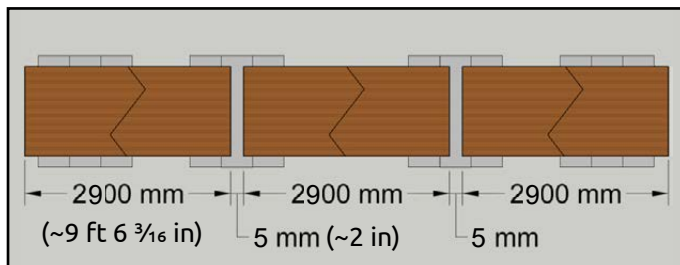

8 POSITIONING STAVES NEXT TO THE EDGE OF THE WALL

Lay the staves in the corner of a wall as shown in the figure. A stave will have a greater boss, up to the outside thread of the perpendicular stave.

To cover the hollow we recommend using a L-shaped profile or using a special aluminium profile.

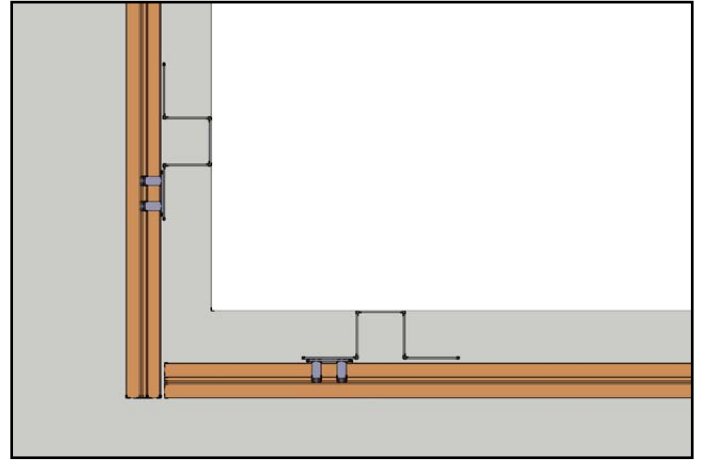

9 STAVES POSITIONING ON THE UPPER EDGE

9.1 Wall with fixed height

Cut a stave close to a hole, creating a smooth finish.

Create a hole on the stave larger than the diameter of the screw of 3 mm (~ 1/8 in) ; this passage is essential to allow the natural expansion of the material.

It is recommended to cover everything with a Corner Novowood composite wood profile or metallic skirt.

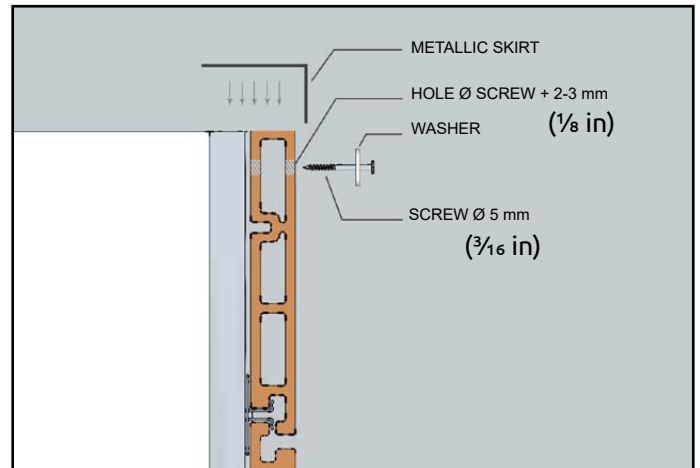

3.d LAYING THE SKIN STAVES 127x15 mm



SUITABLE CLIPS:



Clips
SIN



CAUTION

Wood plastic composite is subject to slight thermal expansion (0.04 mm/m/°C). Ensure that recommended distances are observed.

1 STAVE DISTANCE FROM THE GROUND (STAVES 127x15)

It is necessary to leave a space between the first stave and the ground of **at least 10 mm** (~ 7/16 in), to allow the material ventilation.

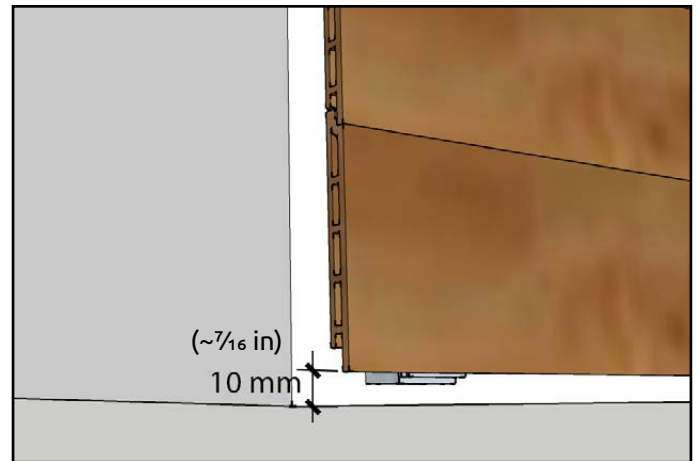

2 POSITIONING THE FIRST ROW OF CLIPS

Position the clips on the joists, as shown in the picture.

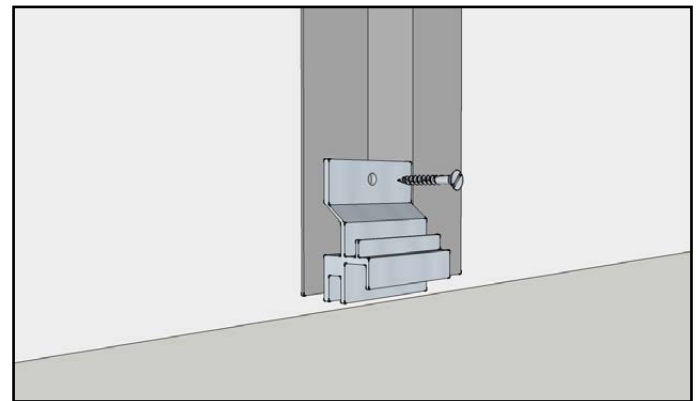

CAUTION

Check the squaring by positioning a stave before final clip fixing.

3 FIRST STAVE POSITIONING

Position the first stave and insert it into the screwed in clips.



CAUTION

Pay particular attention to the orientation of this stave as all the subsequent ones will follow the same direction.

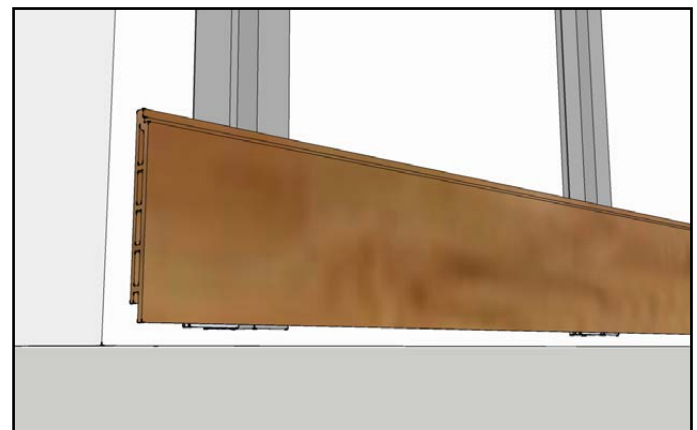

4 CLIP POSITIONING

Position the entire row of clips, screwing them into the joists, as shown in picture.

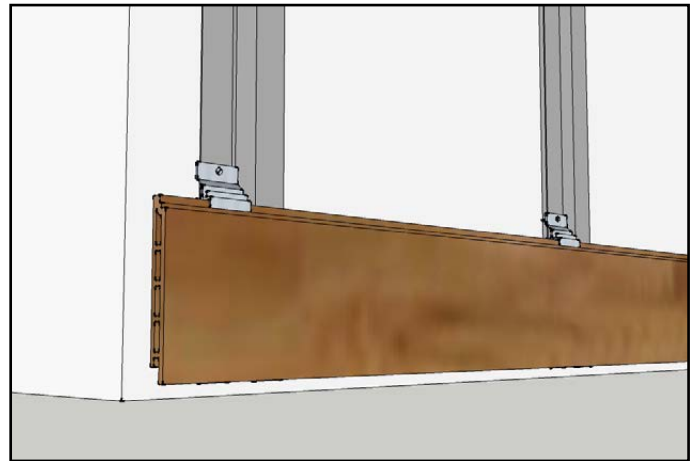

5 SECOND STAVE POSITIONING

Position the second stave, placing it onto the row of clips which have just been installed, and then block it applying a new row of clips above.

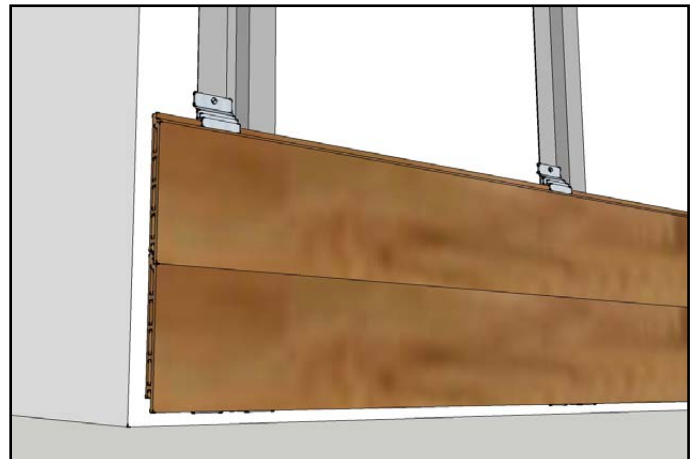

6 COMPLETING INSTALLATION

Repeat steps 4 and 5 until the area to be covered is complete.



7 POSITIONING ADJACENT STAVES

Leave a space of about **3 mm (~1/8 in)** between two adjacent staves to allow the natural thermal expansion of the wood plastic composite. The distance must be evaluated depending on the temperature at moment of the installation and annual climate variations, considering that the solar radiation sensibly modifies the temperature of the material.

- Laying at **10°C (50°F)**= distance **4 mm (~3/16 in)** for staves with a length of 2000 mm (6 ft 6 3/4 in).
- Laying at **20°C (68°F)**= distance **2 mm (~1/16 in)** for staves with a length of 2000 mm (6 ft 6 3/4 in).
- Laying at t_{max} = distance **0 mm (~0 in)** for staves with a length of 2000 mm (6 ft 6 3/4 in).



CAUTION

The 2 adjacent staves will stick to the same omega joist with 2 clips.

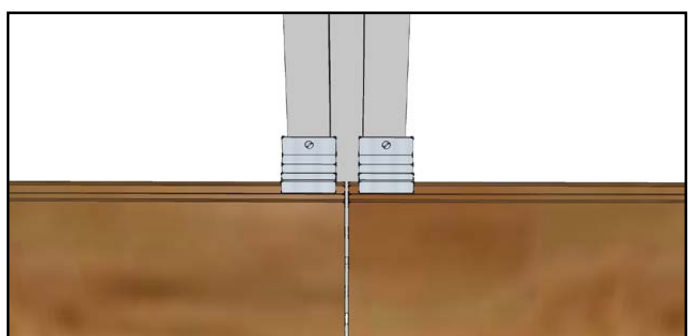
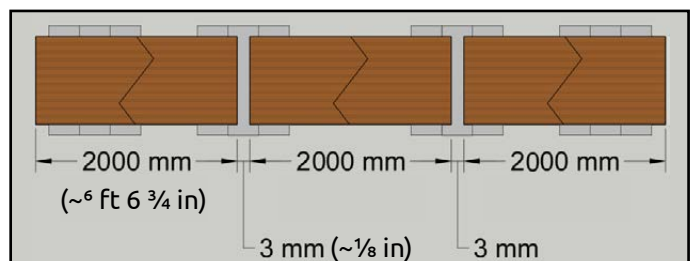

8 POSITIONING STAVES NEXT TO THE EDGE OF THE WALL

Lay the staves in the corner of a wall as shown in the figure. A stave will have a greater boss, up to the outside thread of the perpendicular stave.

To cover the hollow we recommend using a L-shaped profile or using a special aluminium profile.

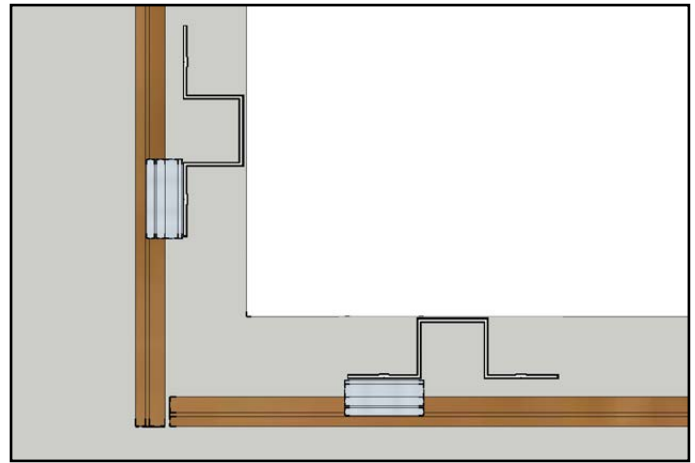

9 STAVES POSITIONING ON THE UPPER EDGE

9.1 Closure with metallic skirt

Calculate the height of the joists multiplying the number of staves necessary to cover the wall and do the cut.

Apply the metallic skirt on the upper edge covering the steel clips.

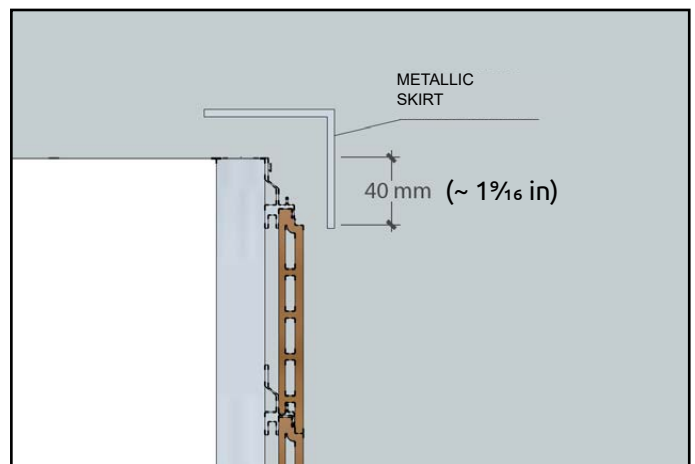

9.2 Closure with corner trim

Create a hole in the stave until you reach the hollow, the hole must have a bigger dimension than the washer;

create a second hole of bigger dimensions than the screw so that you allow the natural thermal expansion of the material.

The second hole must not have bigger dimensions than the washer, in order to avoid not being able to fix the stave to the joist.

The measurements in the image are only for illustrative purposes.

Fix the pierced stave to the joist using a shim; cover everything with a NOVOWOOD corner trim or a metallic skirt.

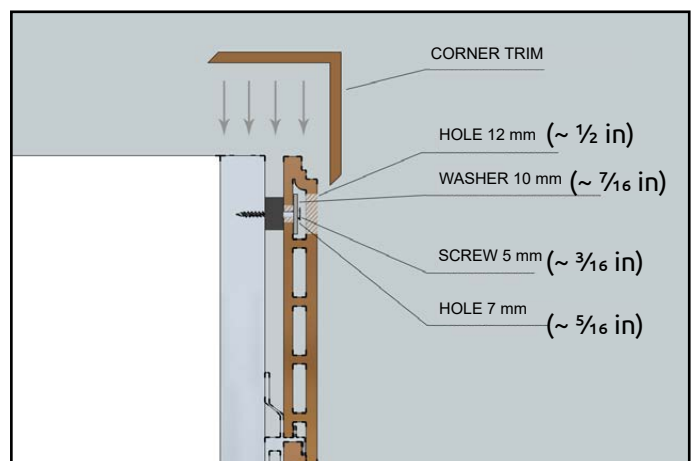
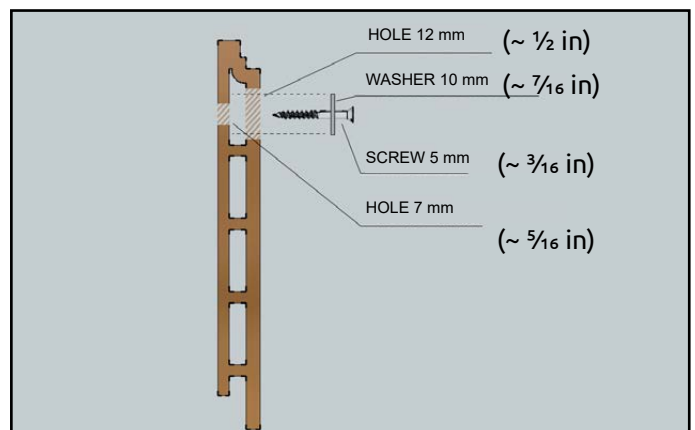

4 WASTAGE

Wastage varies depending on the geometry of the project. A regular shape, for example a square or a rectangle, will produce less waste, while a complex shape with a high number of joints, angles or irregular shapes, will produce more waste. In general, it is estimated to be between 5-10%.

5 MAINTENANCE AND CLEANING

Novowood wood plastic composite does not require special maintenance and it is easy to clean thanks to the studied combination of fibres, polymers and additives. In order to reduce the accumulation of residues on the surface it is advised to monthly wash the Wood Plastic Composite with cleaning products (supplied on request) and in order to maintain the warranty it is necessary to provide at least one annual cleaning with "WPC Cleaner" (supplied on request). If you use the pressure washer, keep the nozzle at a distance of 30 cm (~ 11 ¹³/₁₆ in) from the floor.

The accumulation of organic material on the surface, with the passage of time, may form localised moulds which can be removed using hot water and "WPC Cleaner". If moulds, algae and fungi have settled for a long time, often the material needs further treatment.

However, the inconvenience can be reduced by keeping the decking clean, dry and ensuring good ventilation.

In order to remove localized stains it is advisable to use a special spray "WPC stains remover" (supplied upon request) which may produce a slight hue change in the intervention area.

INFORMATION ON NOVOWOOD'S LIABILITY

The distances to be observed and the method of installation will be evaluated according to the needs of the client and the contractor during laying. The company does not assume any liability for negligence in the installation of NOVOWOOD products.

Please check possible updates of the manuals on the website www.novowood.it in the download section.



NOVOWOOD
HEADQUARTER
Via E. da Rotterdam, 29
44122 Ferrara (FE)

+39 0532 732737
info@novowood.it

www.novowood.it