

## 19" EINTEILIGER WANDVERTEILERSCHRANK, PRO 2nd GENERATION

WCAB PS2 600X450 (B)

### BESCHREIBUNG

- Wirewin® 19" einteiliger Wandverteilerschrank
- Glastür, versperrbar
- abnehmbare Seitenteile mit speziellen verdeckten Feder-Stiftsystem
- 2 Paar 19" Schienen
- die vorderen Schienen sind verstellbar, die hinteren Schienen sind fest
- 600 mm Breite
- 450 mm Tiefe, 600 mm verfügbar
- 4HE / 6HE / 9HE / 12HE / 15HE / 18HE / 21HE Höhre
- getestet bis 100 kg Belastung



### Spezifikationen:

- Material:**
- Hauptkörper (Struktur):  
DIN EN 10130-DC-01-6112 CRS, 0,8 mm
  - Glastüre:  
EN 12150-1 gehärtetes Sicherheitsglas, 4,0 mm
  - 19" Gerätemontageschienen:  
DIN EN 10130-DC-01-6112 CRS, 1,2 mm
  - Hinterer Gehäuserahmen:  
DIN EN 10130-DC-01-6112 CRS, 1,0 mm
  - Seitenteile:  
DIN EN 10130-DC-01-6112 CRS, 0,8 mm

- Farbe:**
- RAL7035, Hellgrau oder RAL9005 Schwarz

- max. Belastung:**
- 100 kg Belastung getestet

- Verpackung:**
- einzeln, Kartonverpackung, montiert

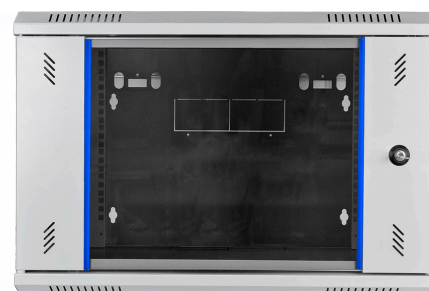

### FARBE: RAL7035, HELLGRAU

HE	ARTIKELNUMMER	BREITE	TIEFE	HÖHE	GEWICHT	EAN NUMMER	V-GEWICHT	VERSANDGRÖSSE
4HE	WCAB PS2 600X450X4U	600	450	278	11,4 kg	9120072487286	13,4 kg	645 x 515 x 292
6HE	WCAB PS2 600X450X6U	600	450	367	13,0 kg	9120072487293	15,0 kg	645 x 515 x 382
9HE	WCAB PS2 600X450X9U	600	450	500	15,8 kg	9120072487309	17,8 kg	645 x 515 x 514
12HE	WCAB PS2 600X450X12U	600	450	633	18,8 kg	9120072487316	21,1 kg	645 x 515 x 677
15HE	WCAB PS2 600X450X15U	600	450	767	21,6 kg	9120072487323	24,1 kg	645 x 515 x 791
18HE	WCAB PS2 600X450X18U	600	450	900	24,2 kg	9120072487330	26,7 kg	645 x 515 x 914
21HE	WCAB PS2 600X450X21U	600	450	1033	26,8 kg	9120072487347	29,8 kg	645 x 515 x 1047

### FARBE: RAL9005, SCHWARZ

HE	ARTIKELNUMMER	BREITE	TIEFE	HÖHE	GEWICHT	EAN NUMMER	V-GEWICHT	VERSANDGRÖSSE
4HE	WCAB PS2 600X450X4U B	600	450	278	11,4 kg	9120072487378	13,4 kg	645 x 515 x 292
6HE	WCAB PS2 600X450X6U B	600	450	367	13,0 kg	9120072487392	15,0 kg	645 x 515 x 382
9HE	WCAB PS2 600X450X9U B	600	450	500	15,8 kg	9120072487415	17,8 kg	645 x 515 x 514
12HE	WCAB PS2 600X450X12U B	600	450	633	18,8 kg	9120072487439	21,1 kg	645 x 515 x 677
15HE	WCAB PS2 600X450X15U B	600	450	767	21,6 kg	9120072487453	24,1 kg	645 x 515 x 791
18HE	WCAB PS2 600X450X18U B	600	450	900	24,2 kg	9120072487477	26,7 kg	645 x 515 x 914
21HE	WCAB PS2 600X450X21U B	600	450	1033	26,8 kg	9120072487491	29,8 kg	645 x 515 x 1047

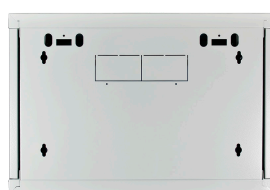
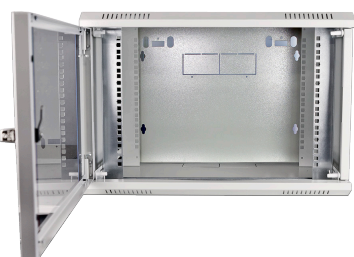

## 19" EINTEILIGER WANDVERTEILERSCHRANK, PRO 2nd GENERATION

WCAB PS2 600X450 (B)

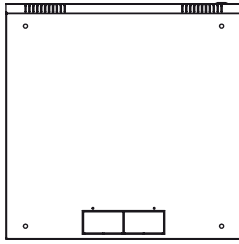

BOTTOM VIEW

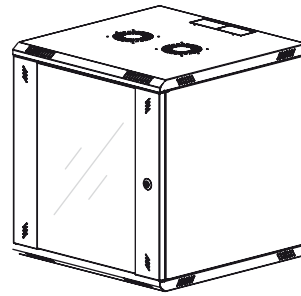

ISOMETRIC VIEW

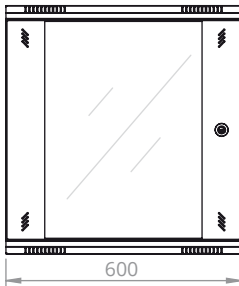

FRONT VIEW

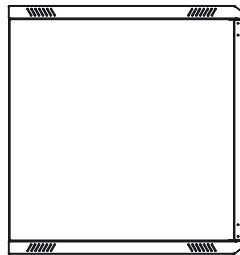

SIDE VIEW

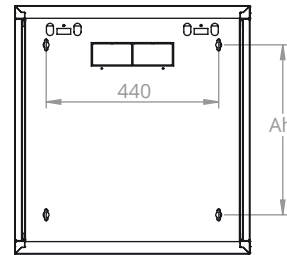

REAR VIEW

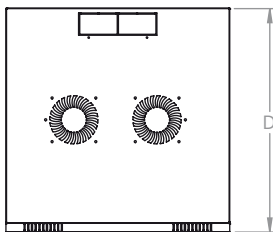

TOP VIEW

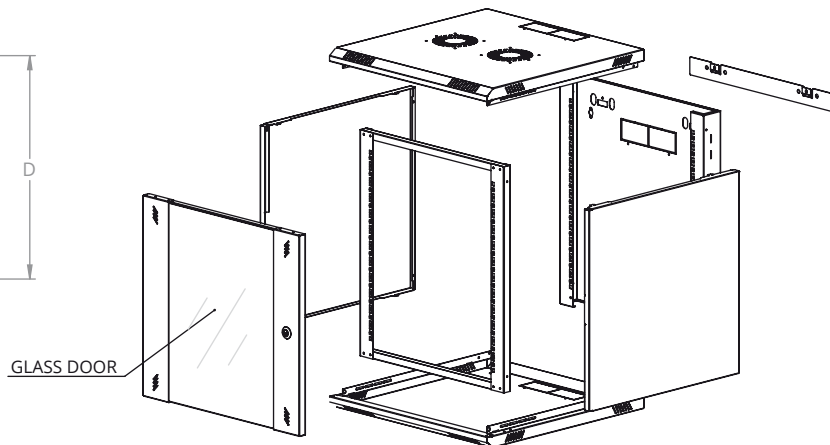

EXPLODED VIEW

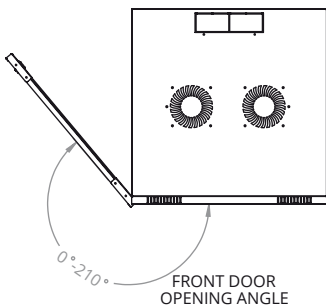

FRONT DOOR  
OPENING ANGLE

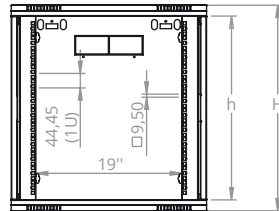

DIMENSIS IN  
WIDTH AND HEIGHT

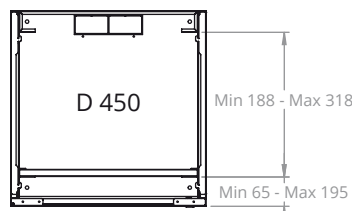

MAX/ MIN EQUIPMENT  
MOUNTING DISTANCE  
(450)

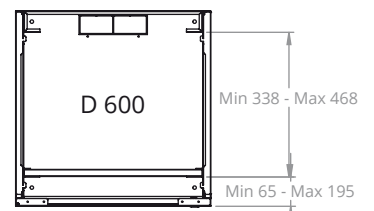

MAX/ MIN EQUIPMENT  
MOUNTING DISTANCE  
(600)

HE	Ah	h	H	D
4HE	78	210	278	600 / 450
6HE	167	299	367	600 / 450
9HE	301	432	500	600 / 450
12HE	434	565	633	600 / 450
15HE	567	698	766	600 / 450
18HE	700	832	900	600 / 450
21HE	834	934	1033	600 / 450