

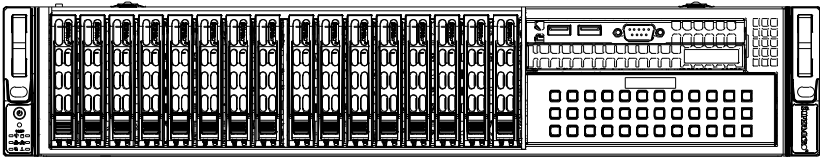

## SC213 CHASSIS SERIES



SC213AC-R1K23LPB

SC213AC-R1K23WB

SC213AC-R920LPB

SC213AC-R920WB

SC213A-R740LPB

SC213A-R740WB

SC213A-R720LPB

SC213A-R720UB

SC213A-R900LPB

SC213A-R900UB

SC213BAC8-R1K23WB

SC213BAC8-R1K23LPB

## USER'S MANUAL

---

The information in this User's Manual has been carefully reviewed and is believed to be accurate. The vendor assumes no responsibility for any inaccuracies that may be contained in this document, makes no commitment to update or to keep current the information in this manual, or to notify any person or organization of the updates. **Please Note: For the most up-to-date version of this manual, please see our web site at [www.supermicro.com](http://www.supermicro.com).**

Super Micro Computer, Inc. ("Supermicro") reserves the right to make changes to the product described in this manual at any time and without notice. This product, including software and documentation, is the property of Supermicro and/or its licensors, and is supplied only under a license. Any use or reproduction of this product is not allowed, except as expressly permitted by the terms of said license.

IN NO EVENT WILL SUPERMICRO BE LIABLE FOR DIRECT, INDIRECT, SPECIAL, INCIDENTAL, SPECULATIVE OR CONSEQUENTIAL DAMAGES ARISING FROM THE USE OR INABILITY TO USE THIS PRODUCT OR DOCUMENTATION, EVEN IF ADVISED OF THE POSSIBILITY OF SUCH DAMAGES. IN PARTICULAR, SUPERMICRO SHALL NOT HAVE LIABILITY FOR ANY HARDWARE, SOFTWARE, OR DATA STORED OR USED WITH THE PRODUCT, INCLUDING THE COSTS OF REPAIRING, REPLACING, INTEGRATING, INSTALLING OR RECOVERING SUCH HARDWARE, SOFTWARE, OR DATA.

Any disputes arising between manufacturer and customer shall be governed by the laws of Santa Clara County in the State of California, USA. The State of California, County of Santa Clara shall be the exclusive venue for the resolution of any such disputes. Super Micro's total liability for all claims will not exceed the price paid for the hardware product.

California Best Management Practices Regulations for Perchlorate Materials: This Perchlorate warning applies only to products containing CR (Manganese Dioxide) Lithium coin cells. "Perchlorate Material-special handling may apply. See [www.dtsc.ca.gov/hazardouswaste/perchlorate](http://www.dtsc.ca.gov/hazardouswaste/perchlorate)"

---

**WARNING: Handling of lead solder materials used in this product may expose you to lead, a chemical known to the State of California to cause birth defects and other reproductive harm.**

---

Manual Revision 1.1  
Release Date: July 06, 2022

Unless you request and receive written permission from Super Micro Computer, Inc., you may not copy any part of this document.

Information in this document is subject to change without notice. Other products and companies referred to herein are trademarks or registered trademarks of their respective companies or mark holders.

Copyright © 2022 by Super Micro Computer, Inc.  
All rights reserved.

**Printed in the United States of America**

# Preface

## About this Manual

This manual is written for professional system integrators and PC technicians. It provides information for the installation and use of the chassis. Installation and maintenance should be performed by experienced technicians only.

This document lists compatible parts available when this document was published. Refer to the Supermicro web site for updates on supported parts and configurations.

## Warnings

Special attention should be given to the following symbols used in this manual.



**Warning!** Indicates important information given to prevent equipment/property damage or personal injury.



**Warning!** Indicates high voltage may be encountered when performing a procedure.

# Contents

Contacting Supermicro .....vii

## **Chapter 1 Introduction**

1-1 Overview ..... 1-1

1-2 Shipping List..... 1-2

1-3 Chassis Features ..... 1-2

    Motherboard Support ..... 1-2

    Drives ..... 1-2

    PCI Expansion Slots ..... 1-2

    Cooling ..... 1-2

    Control Panel ..... 1-2

    Cables ..... 1-2

1-4 Returning Merchandise for Service..... 1-3

1-5 Where to Get Replacement Components ..... 1-3

## **Chapter 2 Rack Installation**

2-1 Unpacking the System ..... 2-1

2-2 Preparing for Setup ..... 2-1

    Choosing a Setup Location ..... 2-1

2-3 Warnings and Precautions ..... 2-2

    Rack Precautions ..... 2-2

    General Server Precautions..... 2-2

    Rack Mounting Considerations ..... 2-3

        Ambient Operating Temperature ..... 2-3

        Sufficient Airflow ..... 2-3

        Circuit Overloading ..... 2-3

        Reliable Ground ..... 2-3

2-4 Installing the System into a Rack ..... 2-4

    Identifying the Sections of the Rack Rails ..... 2-4

    Releasing the Inner Rail ..... 2-5

    Installing the Inner Rails on the Chassis ..... 2-6

    Installing the Outer Rails onto the Rack ..... 2-7

    Sliding the Chassis onto the Rack Rails..... 2-8

## **Chapter 3 System Interface**

3-1 Overview ..... 3-1

3-2 Control Panel Buttons ..... 3-2

    Power ..... 3-2



	Reset .....	3-2
3-3	Control Panel LEDs .....	3-2
	Power .....	3-2
	HDD .....	3-2
	NIC2 .....	3-3
	NIC1 .....	3-3
	Information LED .....	3-3
	Power Fail .....	3-3
	Overheating .....	3-4
	Overheat Temperature Setting .....	3-4
	Responses .....	3-4
3-4	Drive Carrier LEDs .....	3-4
3-5	Power Supply LEDs .....	3-5

#### **Chapter 4 Chassis Setup and Maintenance**

4-1	Overview .....	4-1
4-2	Removing Power from the System .....	4-2
4-3	Removing the Chassis Cover .....	4-3
4-4	Installing Hard Drives .....	4-4
	Installing the Rear 2.5" Hard Drive Cage .....	4-6
	Installing the Rear Drives into Carriers .....	4-8
4-5	Installing Expansion Cards .....	4-9
	Expansion Cards for an LP Model Chassis .....	4-9
	Expansion Cards for a W or U Model Chassis .....	4-9
4-6	Installing the Air Shroud .....	4-12
4-7	Power Supply .....	4-14
4-8	Installing the Power Distributor .....	4-15
4-9	Removing the Backplane .....	4-16

#### **Appendix A SC213 Power Supply Specifications**

#### **Appendix C BPN-SAS-213A Backplane Specifications**

C-1	ESD Safety Guidelines .....	C-1
C-2	General Safety Guidelines .....	C-1
C-3	Version Information .....	C-2
C-4	Rear Connectors and Jumpers .....	C-3
C-5	Rear Connector and Pin Definitions .....	C-4
C-6	Rear Jumper Locations and Pin Definitions .....	C-6
	Explanation of Jumpers .....	C-6
	I <sup>2</sup> C and SGPIO Modes and Jumper Settings .....	C-7

Rear LED Indicators.....	C-8
C-7 Front Components, Connectors and LED Indicators.....	C-9

**Appendix D BPN-SAS3-213A Backplane Specifications**

D-1 ESD Safety Guidelines .....	D-1
D-2 General Safety Guidelines .....	D-1
D-3 Version Information .....	D-2
D-4 Rear Connectors .....	D-3
Front Connectors .....	D-3
D-5 Rear Connector and Pin Definitions .....	D-4
D-6 Rear Jumper Locations and Pin Definitions .....	D-5
Explanation of Jumpers .....	D-5
D-7 Front Connectors and LED Indicators .....	D-6

**Appendix E BPN-SAS3-213A-N8 Backplane Specifications**

E-1 ESD Safety Guidelines .....	E-1
E-2 General Safety Guidelines .....	E-1
E-3 A Note to Users.....	E-1
E-4 Introduction to the BPN-SAS3-213A-N8 Backplane .....	E-2
E-5 Front Connectors .....	E-3
Front Connectors .....	E-3
E-6 Front Connector and Pin Definitions.....	E-4
E-7 Front Jumpers .....	E-5
Explanation of Jumpers .....	E-5
E-8 Rear Components, Connectors, and LED Indicators .....	E-7

## Contacting Supermicro

### Headquarters

Address: Super Micro Computer, Inc.  
980 Rock Ave.  
San Jose, CA 95131 U.S.A.

Tel: +1 (408) 503-8000

Fax: +1 (408) 503-8008

Email: [marketing@supermicro.com](mailto:marketing@supermicro.com) (General Information)  
[support@supermicro.com](mailto:support@supermicro.com) (Technical Support)

Web Site: [www.supermicro.com](http://www.supermicro.com)

### Europe

Address: Super Micro Computer B.V.  
Het Sterrenbeeld 28, 5215 ML  
's-Hertogenbosch, The Netherlands

Tel: +31 (0) 73-6400390

Fax: +31 (0) 73-6416525

Email: [sales@supermicro.nl](mailto:sales@supermicro.nl) (General Information)  
[support@supermicro.nl](mailto:support@supermicro.nl) (Technical Support)  
[rma@supermicro.nl](mailto:rma@supermicro.nl) (Customer Support)

Web Site: [www.supermicro.nl](http://www.supermicro.nl)

### Asia-Pacific

Address: Super Micro Computer, Inc.  
3F, No. 150, Jian 1st Rd.  
Zhonghe Dist., New Taipei City 235  
Taiwan (R.O.C)

Tel: +886-(2) 8226-3990

Fax: +886-(2) 8226-3992

Email: [support@supermicro.com.tw](mailto:support@supermicro.com.tw)

Web Site: [www.supermicro.com.tw](http://www.supermicro.com.tw)

# Chapter 1

## Introduction

### 1-1 Overview

The Supermicro SC213 chassis features a direct-attached SAS3 backplane supporting sixteen 2.5" SAS/SATA hard disk drives. It has dual highly efficient redundant power supplies, an optional DVD drive, two USB ports, three 80mm fans, and room for seven PCI Express expansion cards.

SC213 Chassis Series			
Model	HDD	PCI Slots	Power Supply
SC213AC-R1K23LPB	16x 2.5" hot-swap SAS/SATA	7x LP	1200W (Redundant, Titanium)
SC213AC-R1K23WB	16x 2.5" hot-swap SAS/SATA	4x FH & 3x LP	1200W (Redundant, Titanium)
SC213BAC8-R1K23WB	16x 2.5" hot-swap SAS/SATA	4x FH & 3x LP	1200W (Redundant, Titanium)
SC213BAC8-R1K23LPB	16x 2.5" hot-swap SAS/SATA	7x LP	1200W (Redundant, Titanium)
SC213AC-R920LPB	16x 2.5" hot-swap SAS/SATA	7x LP	920W (Redundant, Platinum)
SC213AC-R920WB	16x 2.5" hot-swap SAS/SATA	4x FH & 3x LP	920W (Redundant, Platinum)
SC213A-R740LPB	16x 2.5" hot-swap SAS/SATA	7x LP	740W (Redundant, Platinum)
SC213A-R740WB	16x 2.5" hot-swap SAS/SATA	4x FH & 3x LP	740W (Redundant, Platinum)
SC213A-R720LPB	16x 2.5" hot-swap SAS/SATA	7x LP	720W (Redundant, Gold)
SC213A-R720UB	16x 2.5" hot-swap SAS/SATA	4x FH & 3x LP	720W (Redundant, Gold)
SC213A-R900LPB	16x 2.5" hot-swap SAS/SATA	7x LP	900W (Redundant)
SC213A-R900UB	16x 2.5" hot-swap SAS/SATA	4x FH & 3x LP	900W (Redundant)

## 1-2 Shipping List

Visit the Supermicro web site for the latest shipping lists and part numbers for your particular chassis model at [www.supermicro.com](http://www.supermicro.com).

## 1-3 Chassis Features

The SC213 3U high-performance chassis includes the following features:

### **Motherboard Support**

The chassis supports motherboard sizes of 13.68" x 13.0", E-ATX, ATX form factors. It supports dual and single Intel and AMD processors.

### **Drives**

The chassis supports up to sixteen 2.5" hot-swap SAS or SATA drives with SES2. With RAID, these drives may be replaced without powering down the server. It also supports one slim DVD drive (optional).

### **PCI Expansion Slots**

Each version of the chassis includes seven slots with sizes depending on the model.

### **Cooling**

Three hot-plug 80mm fans provide cooling, aided by an air shroud. The 4-pin fans are controlled through IPMI.

### **Control Panel**

The front control panel includes system status LED indicators and power switches.

### **Cables**

To determine what cables are needed for your system, check the connector type of your system backplane and motherboard. Then consult the Supermicro website. [https://www.supermicro.com/ResourceApps/Cable\\_Matrix.aspx](https://www.supermicro.com/ResourceApps/Cable_Matrix.aspx)

## 1-4 Returning Merchandise for Service

A receipt or copy of your invoice marked with the date of purchase is required before any warranty service will be rendered. You can obtain service by calling your vendor for a Returned Merchandise Authorization (RMA) number. When returning to the manufacturer, the RMA number should be prominently displayed on the outside of the shipping carton, and mailed prepaid or hand-carried. Shipping and handling charges will be applied for all orders that must be mailed when service is complete.

For faster service, RMA authorizations may be requested online (<http://www.supermicro.com/support/rma/>).

Whenever possible, repack the chassis in the original Supermicro carton, using the original packaging material. If these are no longer available, be sure to pack the chassis securely, using packaging material to surround the chassis so that it does not shift within the carton and become damaged during shipping.

This warranty only covers normal consumer use and does not cover damages incurred in shipping or from failure due to the alteration, misuse, abuse or improper maintenance of products.

During the warranty period, contact your distributor first for any product problems.

## 1-5 Where to Get Replacement Components

Although not frequently, you may need replacement parts for your system. To ensure the highest level of professional service and technical support, we strongly recommend purchasing exclusively from our Supermicro Authorized Distributors/System Integrators/Resellers. A list of Supermicro Authorized Distributors/System Integrators/Resellers can be found at: [www.supermicro.com](http://www.supermicro.com). Click the Where to Buy link

# Notes

# Chapter 2

## Rack Installation

This chapter provides instructions for preparing and mounting your chassis in a rack.

### 2-1 Unpacking the System

You should inspect the box the chassis was shipped in and note if it was damaged in any way. If the chassis itself shows damage, file a damage claim with the carrier who delivered it.

### 2-2 Preparing for Setup

Decide on a suitable location for the rack unit that will hold your chassis. It should be a clean, dust-free area that is well ventilated. Avoid areas where heat, electrical noise and electromagnetic fields are generated. A nearby grounded power outlet is required.

The box your chassis was shipped in should include two sets of rail assemblies, two rail mounting brackets and the mounting screws to mount the system into the rack. Please read this chapter in its entirety before beginning the installation procedure.

#### Choosing a Setup Location

- Leave at least 25 inches clearance in front of the rack to open the front door completely.
- Leave approximately 30 inches of clearance in the back of the rack to allow for sufficient airflow and access for servicing.
- It should be a restricted access location, such as a dedicated equipment room or a service closet.



## 2-3 Warnings and Precautions

### Rack Precautions

- Ensure that the leveling jacks on the bottom of the rack are fully extended to the floor with the full weight of the rack resting on them.
- In single rack installations, stabilizers should be attached to the rack.
- In multiple rack installations, the racks should be coupled together.
- Always make sure that the rack is stable before extending a component from the rack.
- Only one chassis should be extended from the rack at a time. Extending two or more chassis simultaneously may cause the rack to become unstable.

### General Server Precautions

- Review the electrical and general safety precautions that came with the components you are adding to your chassis.
- Determine the placement of each component in the rack *before* you install the rails.
- Install the heaviest server components on the bottom of the rack first, and then work upward.
- Use a regulating uninterruptible power supply (UPS) to protect the server from power surges, voltage spikes and to keep your system operating in case of a power failure.
- Allow the hot-swappable hard drives and power supply modules to cool before touching them.
- Always keep the rack's front door and all panels and components on the servers closed when not servicing to maintain proper cooling.

## Rack Mounting Considerations

### ***Ambient Operating Temperature***

If installed in a closed or multi-unit rack assembly, the ambient operating temperature of the rack environment may be greater than the ambient temperature of the room. Therefore, consideration should be given to installing the equipment in an environment compatible with the manufacturer's maximum rated ambient temperature (TMRA).

### ***Sufficient Airflow***

Equipment should be mounted into a rack so that the amount of airflow required for safe operation is not compromised.

### ***Circuit Overloading***

Consideration should be given to the connection of the equipment to the power supply circuitry and the effect that any possible overloading of circuits might have on overcurrent protection and power supply wiring. Appropriate consideration of equipment nameplate ratings should be used when addressing this concern.

### ***Reliable Ground***

A reliable ground must be maintained at all times. To ensure this, the rack itself should be grounded. Particular attention should be given to power supply connections other than the direct connections to the branch circuit (i.e. the use of power strips, etc.).



**Warning:** To prevent bodily injury when mounting or servicing this unit in a rack, you must take special precautions to ensure that the system remains stable. The following guidelines are provided to ensure your safety:

- This unit should be mounted at the bottom of the rack if it is the only unit in the rack.
- When mounting this unit in a partially filled rack, load the rack from the bottom to the top with the heaviest component at the bottom of the rack.
- If the rack is provided with stabilizing devices, install the stabilizers before mounting or servicing the unit in the rack.
- Slide rail mounted equipment is not to be used as a shelf or a work space.

## 2-4 Installing the System into a Rack

This section provides information on installing the server into a rack unit with the rack rails provided. There are a variety of rack units on the market, so the assembly procedure may differ slightly. Refer to the installation instructions that came with your rack. **Note:** This rail will fit a rack between 26.5" and 36.4" deep.

### Identifying the Sections of the Rack Rails

The chassis package includes two rail assemblies. Each assembly consists of three sections: An inner rail that secures directly to the chassis, an outer rail that secures to the rack, and a middle rail which extends from the outer rail. These assemblies are specifically designed for the left and right side of the chassis.

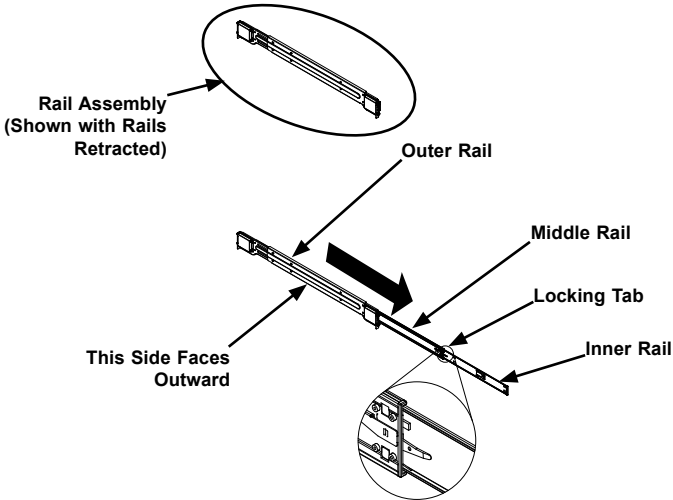

**Figure 2-1. Identifying the Outer Rail, Middle Rail and Inner Rail**  
(Left Rail Assembly Shown)

## Releasing the Inner Rail

Each inner rail has a locking latch. This latch prevents the server from coming completely out of the rack when the chassis is pulled out for servicing.

To mount the rail onto the chassis, first release the inner rail from the outer rails.

### *Releasing Inner Rail from the Outer Rails*

1. Pull the inner rail out of the outer rail until it is fully extended as illustrated below.
2. Press the locking tab down to release the inner rail.
3. Pull the inner rail all the way out.
4. Repeat for the other outer rail.

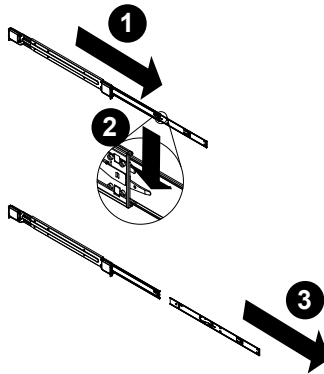

**Figure 2-2. Extending and Releasing the Inner Rail**

## Installing the Inner Rails on the Chassis

### *Installing the Inner Rails*

1. Identify the left and right inner rails. They are labeled.
2. Place the inner rail firmly against the side of the chassis, aligning the hooks on the side of the chassis with the holes in the inner rail.
3. Slide the inner rail forward toward the front of the chassis until the quick release bracket snaps into place, securing the rail to the chassis.
4. Optionally, you can further secure the inner rail to the chassis with a screw.
5. Repeat for the other inner rail.

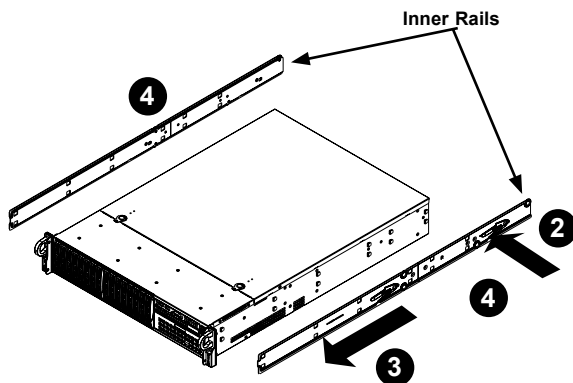

Figure 2-3. Installing the Inner Rails

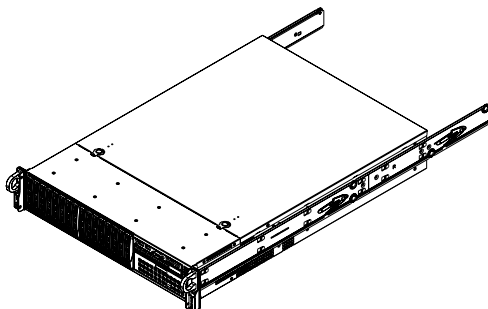
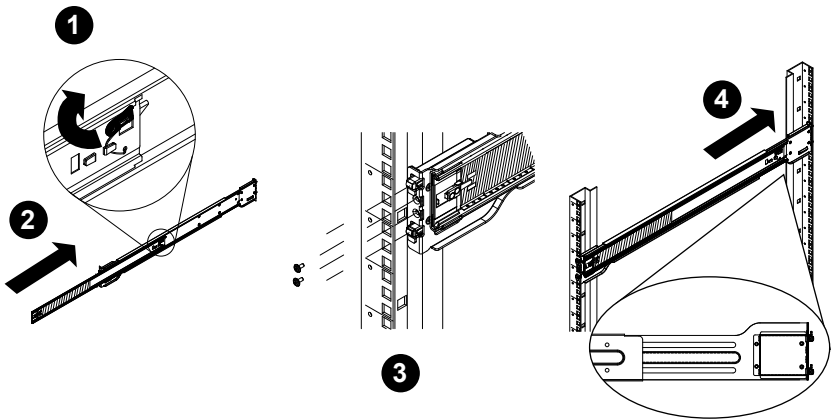

Figure 2-4. Inner Rails Installed on the Chassis

## Installing the Outer Rails onto the Rack

### *Installing the Outer Rails*

1. Press upward on the locking tab at the rear end of the middle rail.
2. Push the middle rail back into the outer rail.
3. Hang the hooks on the front of the outer rail onto the square holes on the front of the rack. If desired, use screws to secure the outer rails to the rack.
4. Pull out the rear of the outer rail, adjusting the length until it just fits within the posts of the rack.
5. Hang the hooks of the rear section of the outer rail onto the square holes on the rear of the rack. Take care that the proper holes are used so the rails are level. If desired, use screws to secure the rear of the outer rail to the rear of the rack.



**Figure 2-5. Extending and Mounting the Outer Rails**



**Stability hazard.** The rack stabilizing mechanism must be in place, or the rack must be bolted to the floor before you slide the unit out for servicing. Failure to stabilize the rack can cause the rack to tip over.

Do not use a two post "telco" type rack.

## Sliding the Chassis onto the Rack Rails



**Warning:** Mounting the system into the rack requires at least two people to support the chassis during installation. Please follow safety recommendations printed on the rails.

### *Installing the Chassis into a Rack*

1. Extend the outer rails as illustrated above.
2. Align the inner rails of the chassis with the outer rails on the rack.
3. Slide the inner rails into the outer rails, keeping the pressure even on both sides. When the chassis has been pushed completely into the rack, it should click into the locked position.
4. Optional screws may be used to hold the front of the chassis to the rack.

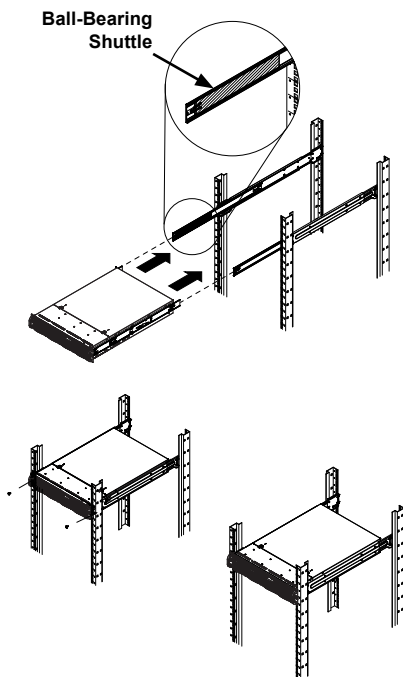

**Figure 2-6. Installing into a Rack**

**Note:** The figure above is for illustrative purposes only. Always install servers to the bottom of the rack first.



**Caution:** Do not pick up the server with the front handles. They are designed to pull the system from a rack only.

## Chapter 3

# System Interface

### 3-1 Overview

The server includes a control panel on the front that houses power buttons and status monitoring lights. The externally accessible hard drives display status lights. The power supply displays status lights visible from the back of the chassis.

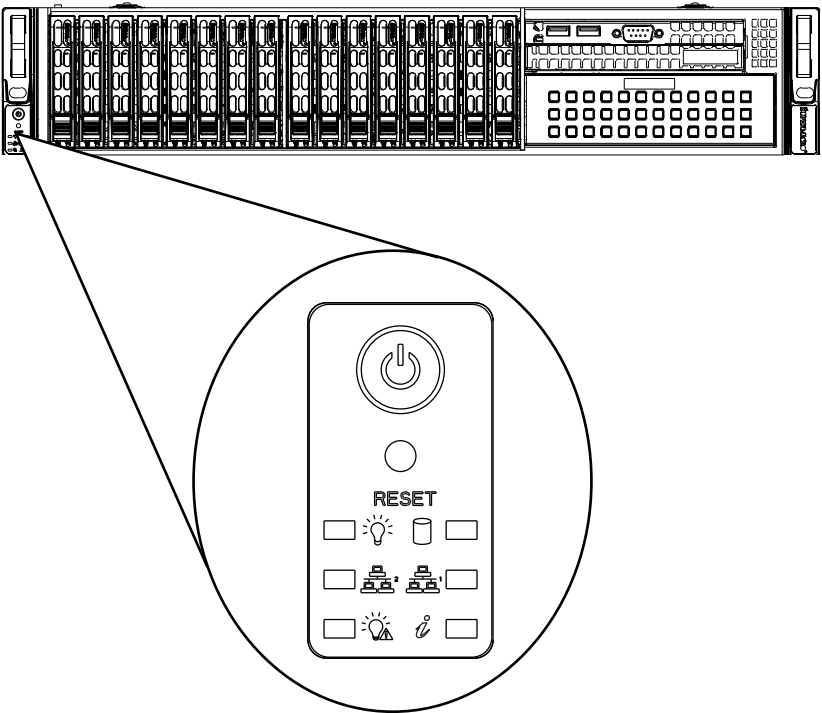

Figure 3-1. Front Control Panel



## 3-2 Control Panel Buttons

The chassis includes two push-buttons that control power to the system.



### Power

The main power switch applies or removes primary power from the power supply to the server but maintains standby power. To perform most maintenance tasks, unplug the system to remove all power..



RESET

### Reset

The reset button is used to reboot the system.

## 3-3 Control Panel LEDs

There are six LEDs that provide status information about the system.



### Power

Indicates power is being supplied to the system power supply units. This LED is illuminated when the system is operating normally.



### HDD

Indicates activity on the hard disk drive when flashing.



## NIC2

Indicates network activity on GLAN2 when flashing.



## NIC1

Indicates network activity on GLAN1 when flashing.



## Information LED

Alerts operator to several states, as noted in the table below.

Information LED	
Status	Description
Continuously on and red	An overheat condition has occurred. (This may be caused by cable congestion.)
Blinking red (1Hz)	Fan failure, check for an inoperative fan.
Blinking red (0.25Hz)	Power failure, check for a non-operational power supply.
Solid blue	Local UID has been activated. Use this function to locate the server in a rack mount environment.
Blinking blue	Remote UID is on. Use this function to identify the server from a remote location.



## Power Fail

Indicates a power supply module has failed.

## Overheating

There are several possible responses if the system overheats.

### ***Overheat Temperature Setting***

Some backplanes allow the overheat temperature to be set at 45, 50, or 55 by changing a jumper setting. For more information, consult the backplane user manual at [www.supermicro.com](http://www.supermicro.com). (Click Support, then the Manuals link.)

### ***Responses***

#### ***If the server overheats:***

1. Use the LEDs to determine the nature of the overheating condition.
2. Confirm that the chassis covers are installed properly.
3. Check the routing of the cables and make sure all fans are present and operating normally.
4. Verify that the heatsinks are installed properly.

## 3-4 Drive Carrier LEDs

The chassis includes externally accessible SAS/SATA drives. Each drive carrier displays two status LEDs on the front of the carrier.

	LED Color	Blinking Pattern	Behavior for Device
<b>Activity LED</b>	Blue	Solid On	SAS drive installed
	Blue	Blinking	I/O activity
<b>Status LED</b>	Red	Solid On	Failed drive for SAS/SATA/NVMe with RSTe support
	Red	Blinking at 1 Hz	Rebuild drive for SAS/SATA with RSTe support
	Red	Blinking with two blinks and one stop at 1 Hz	Hot spare for SAS/SATA with RSTe support
	Red	On for five seconds, then off	Power on for SAS/SATA with RSTe support
	Red	Blinking at 4 Hz	Identify drive for SAS/SATA with RSTe support

## 3-5 Power Supply LEDs

On the rear of the power supply module, an LED displays the status.

- **Solid Green:** When illuminated, indicates that the power supply is on.
- **Solid Amber:** When illuminated, indicates the power supply is plugged in and turned off, or the system is off but in an abnormal state.
- **Blinking Amber:** When blinking, this system power supply temperature has reached 63C. The system will automatically power-down when the power supply temperature reaches 70C and restart when the power supply temperature goes below 60C.

## Notes

## Chapter 4

# Chassis Setup and Maintenance

### 4-1 Overview

This chapter covers the steps required to install components and perform maintenance on the chassis. The only tool required is a Phillips screwdriver.

Review the warnings and precautions listed in the manual before setting up or servicing this chassis. These include information in Chapter 2: System Safety and the warning/precautions listed in the setup instructions.

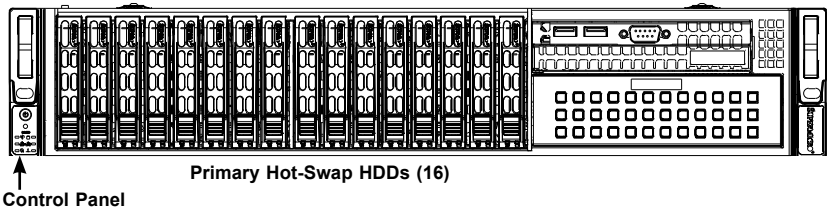

Figure 4-1. Front View

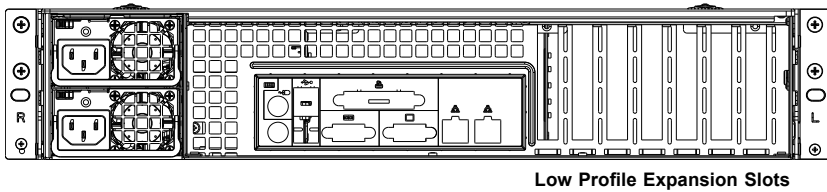

Figure 4-2. Rear View LP Models

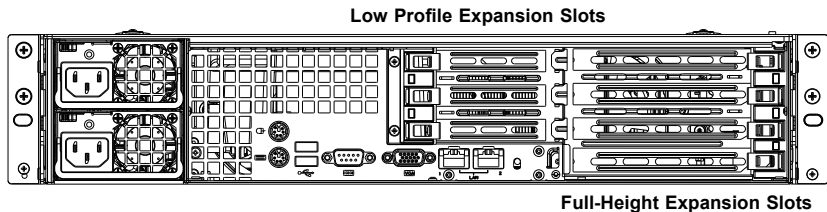

Figure 4-3. Rear View W and U Models

## 4-2 Removing Power from the System

Before performing some setup or maintenance tasks, use the following procedure to ensure that power has been removed from the system.

1. Use the operating system to power down the node, following the on-screen prompts.
2. After the system has completely shut-down, carefully grasp the head of the power cord and gently pull it out of the back of the power supply. If your system has dual power supplies, remove the cords from both power supplies.
3. Disconnect the cord from the power strip or wall outlet.

### 4-3 Removing the Chassis Cover

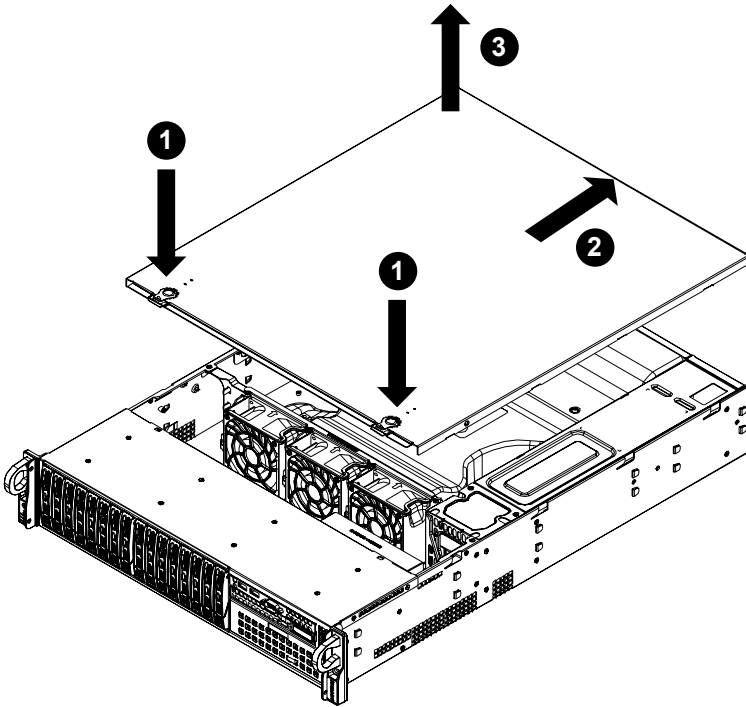

Figure 4-4. Removing the Chassis Cover

#### *Removing the Chassis Cover*

1. Press both release tabs at the same time to release the cover from the locked position.
2. Once the top cover has been released, slide the cover backwards, toward the rear of the chassis.
3. Lift the cover up and off the chassis.

**Caution:** Except for short periods of time, do not operate the server without the cover in place. The chassis cover must be in place to allow proper airflow and prevent overheating.



## 4-4 Installing Hard Drives

The chassis supports sixteen hot-swap hard drives. Only SAS or enterprise SATA HDDs are recommended. The drives are mounted in drive carriers to simplify their installation and removal from the chassis. These carriers also help promote proper airflow for the drive bays.

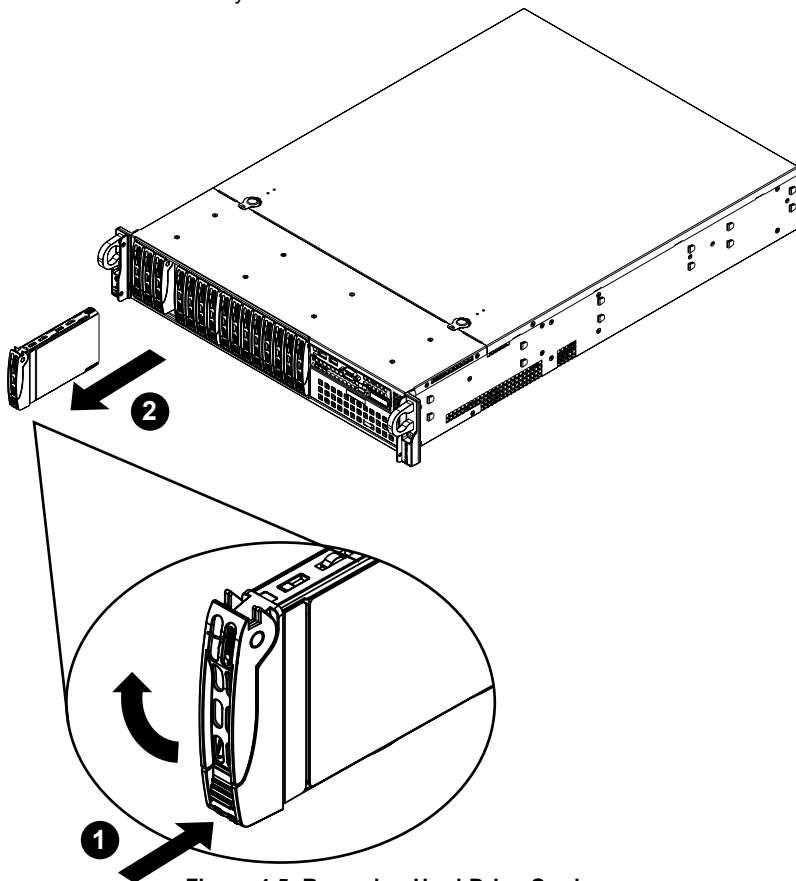
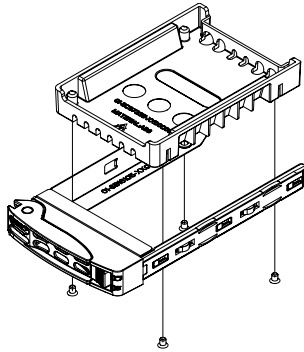

Figure 4-5. Removing Hard Drive Carrier

### *Removing a Hard Drive Carrier from the Bay*

1. Press the release button on the drive carrier. This extends the drive carrier handle.
2. Hold the handle to pull the tray out of the chassis.



**Figure 4-6. Chassis Drive Carrier**

### ***Installing a Hard Drive into a Drive Carrier***

1. Insert a drive into the carrier with the PCB side facing down and the connector end toward the rear of the carrier.
2. Align the drive in the carrier so that the mounting holes of both are aligned. Note that there are holes in the carrier marked "SAS" or "SATA" to aid in correct installation.
3. Secure the drive to the carrier with four screws as illustrated above. Use the four M3 flat-head screws included in the HDD bag of your accessory box. Note that the screws used to secure the dummy drive to the tray cannot be used to secure the hard drive.
4. Insert the hard drive and drive carrier into its bay vertically, keeping the carrier oriented so that the release button is on the bottom. When the carrier reaches the rear of the bay, the release handle will retract.
5. Using the thumb, push against the upper part of the hard drive handle. Push the hard drive into the hard drive bay as illustrated below, until the hard drive clicks into the locked position.

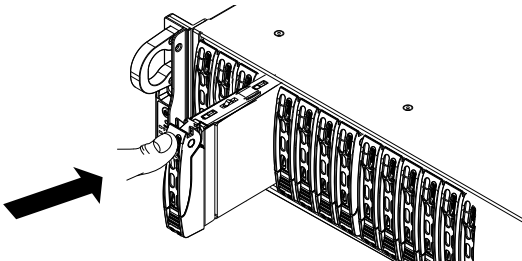

**Figure 4-7. Installing the Hard Drive and Carrier into the Bay**

## Installing the Rear 2.5" Hard Drive Cage (SC213B)

The SC213B model chassis supports an optional hard drive cage for two additional 2.5" hot-swappable hard drives. The hard drive cage installs in the rear of the chassis next to the power supply. Once the hard drive cage has been installed, the 2.5" hard drives may be removed without powering down the server.

### *Installing the 2.5" Rear Hard Drive Cage*

1. Power down as described in section 4-2, lay the chassis on a flat, stable surface and remove the chassis cover.
2. Remove the three screws connecting the bezel and lift the bezel off.
3. Remove the two standoffs.

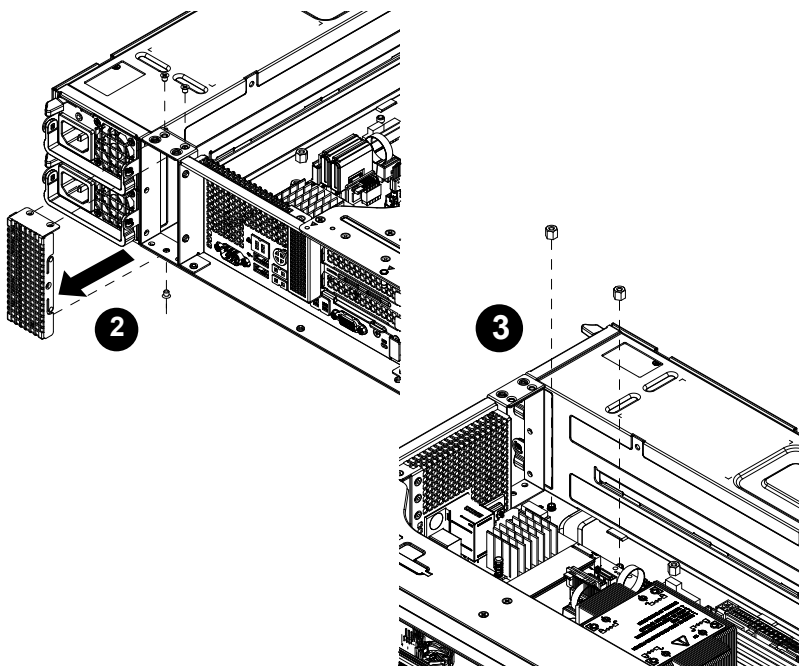

**Figure 4-8. Installing the Rear 2.5" Hard Drive Cage**

**Note:** Keep these two removable standoffs after installing the rear hard drive cage. If you want to remove the rear hard drive cage in the future, these two removable standoffs will need to be placed back to the chassis to ensure there are no opening holes on the chassis base.

4. Loosen the two screws outside and one screw inside the opening of the hard drive cage as illustrated.
5. Orient the 2.5" rear hard drive cage as shown, aligning the opening at the end of the cage with the opening at the back of the chassis. Place the hard drive cage into the chassis.

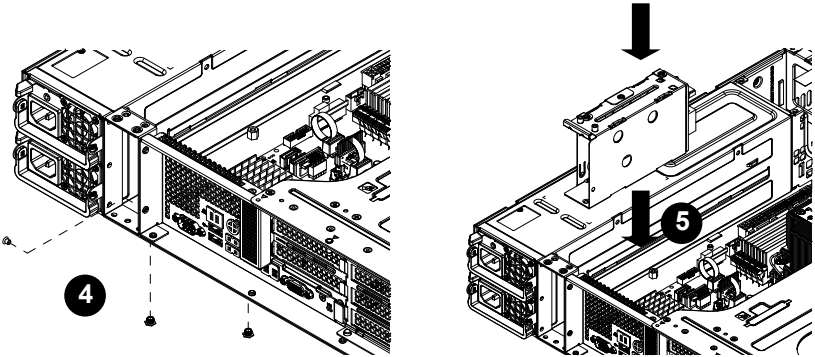

6. Secure the front of the hard drive cage to the chassis by fastening one screw inside the opening of the hard drive cage as illustrated. Secure the top of the hard drive cage to the chassis frame with two screws, fastened at the upper edge of the hard drive cage above the opening of the hard drive cage.
7. Secure the back of the hard drive cage to the chassis with one screw as shown above.
8. Replace the power cords and power up the server.

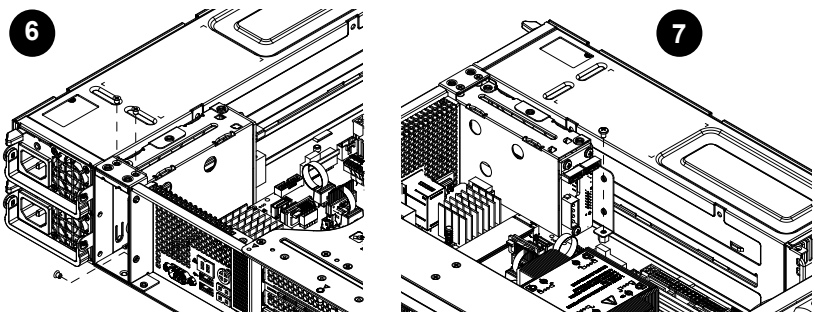

Figure 4-9. Securing the Rear Hard Drive Cage to the Chassis

## Installing the Rear Drives into Carriers (SC213B)

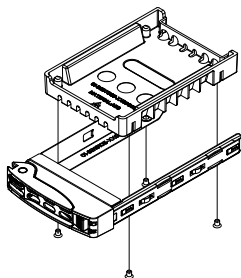

Figure 4-10. Removing the Dummy Drive from the Drive Carrier

### *Installing a Hard Drive into a 2.5" Rear Drive Carrier*

1. Insert a hard drive into the carrier with the PCB side facing down and the connector end toward the rear of the carrier.
2. Align the drive in the carrier so that the mounting holes of both are aligned. Note that there are holes in the carrier marked "SAS" or "SATA" to aid in correct installation.
3. Secure the drive to the carrier with four screws. Use the four M3 flat-head screws included in the HDD bag of your accessory box. Note that the screws used to secure the dummy drive to the tray cannot be used to secure the hard drive.
4. Insert the drive and carrier into its bay vertically, keeping the carrier oriented so that the release button is on the bottom. When the carrier reaches the rear of the bay, the release handle will retract.
5. Using the thumb, push against the upper part of the drive handle. Push the drive and carrier into the bay as illustrated below, until the carrier clicks into the locked position.

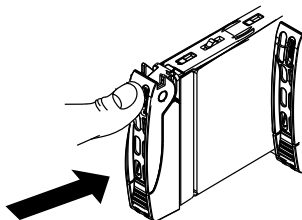

Figure 4-11. Installation of the Hard Drive into the Rear Cage Bay

## 4-5 Installing Expansion Cards

For the LP models, such as SC213AC-R920LPB, the chassis slots are vertical and allow the addition of low profile expansion cards. For the W models such as SC213AC-R920WB, and the U models such as SC213A-R720UB the chassis slots are horizontal. The U models allow a Supermicro universal I/O (UIO) card in addition to expansion cards.

The serverboard must be installed before expansion cards.

### Expansion Cards for an LP Model Chassis

The LP model chassis includes seven slots for low profile expansion cards.

#### *Installing an Expansion Card for an LP Model Chassis*

1. Power down the system as described in Section 4-2 and remove the cover.

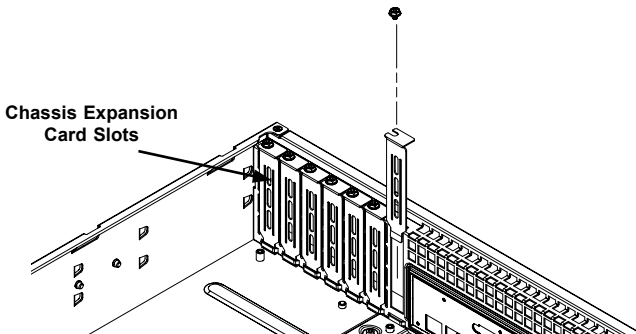

**Figure 4-12. Remove an LP Expansion Card Slot Shield**

2. In the rear of the chassis, remove the blank PCI shield that is pre-installed covering the expansion slot.
3. Slide the expansion card into the expansion slot on the serverboard while aligning it with the chassis slot in the rear of the chassis.
4. Secure the expansion card shield onto the rear of the chassis with a screw.

### Expansion Cards for a W or U Model Chassis

The W or U model chassis accommodates expansion cards using riser cards. If your serverboard supports a Supermicro universal I/O (UIO) card, the U model chassis

supports an additional three full-height expansion cards and three low profile expansion cards. If the serverboard does not support a UIO, then the W model chassis supports four full-height expansion cards and three low profile expansion cards.

### ***Installing a UIO Card***

1. Power down the system as described in Section 4-2 and remove the cover.
2. Release the clamp that secures all four full-height PCI shields (Figure 4-9). Looking at the rear of the chassis, this clamp is in the right corner. Unscrew the single screw that secures the clamp and rotate the clamp away from the shields. Remove the blank PCI shield covering the expansion slot in the chassis.
3. Place the UIO card horizontally in the rear left area of the chassis bottom and insert it into the UIO slot in the serverboard, while aligning it with slot in the rear of the chassis.
4. Secure the shield to the rear of the chassis with the lever.

### ***Installing an Expansion Card for a W or U Model Chassis***

1. If this is the first expansion card, start by locating the *riser card bracket* in your chassis accessory bag, and one or two riser cards, which are purchased separately. One riser card accommodates the full-height expansion cards and another riser card accommodates the three low profile expansion cards.
2. Power down the system as described in Section 4-2 and remove the cover.

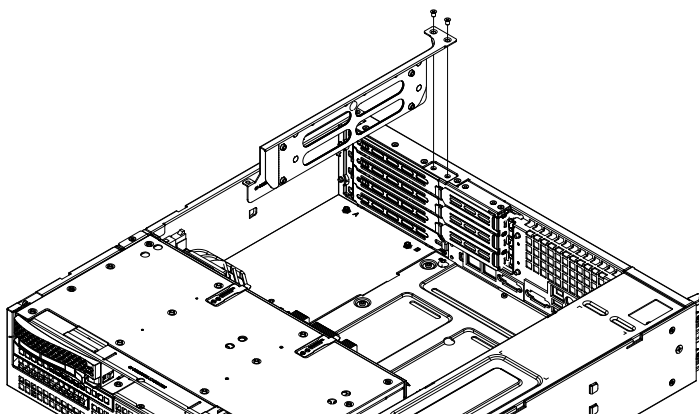

**Figure 4-13. Riser Card Bracket**

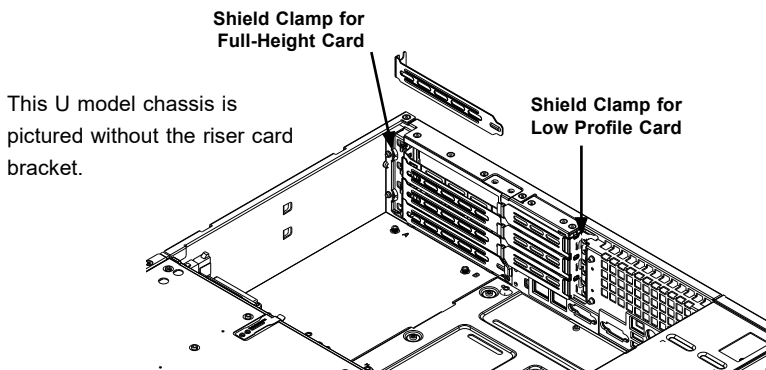

**Figure 4-14. Remove an Expansion Card Slot Shield**

3. Attach the riser card(s) to the riser card bracket using screws. Note that there are different cards for the right and left side of the bracket.
4. Insert the riser card(s) into the serverboard expansion slot(s) while aligning the riser card bracket with the rear of the chassis. Secure the bracket with screws (Figure 4-9).
5. For a **full-height** extension card, release the clamp that secures all four PCI shields. Looking at the rear of the chassis, this clamp is in the right corner. Unscrew the single screw that secures the clamp and rotate the clamp away from the shields.

For a **low profile** extension card, release the box-shaped clamp that secures all three PCI shields. Looking at the rear of the chassis, this clamp is near the middle, just left of the low profile PCI slots. Unscrew the single screw that secures the clamp and slide the clamp to the left away from the shields.

6. Insert the expansion card into a slot on the riser card while aligning the expansion card backplate with the open slot in the rear of the chassis. Repeat for other expansion cards if you are installing more than one.
7. Secure the card backplates to the chassis by returning the clamp to the closed position and installing the locking screw.
8. Replace the chassis cover and power up.



## 4-6 Installing the Air Shroud

Air shrouds concentrate airflow to maximize fan efficiency. It does not require screws for installation. UIO models require an additional air shroud that must be installed before the main shroud..

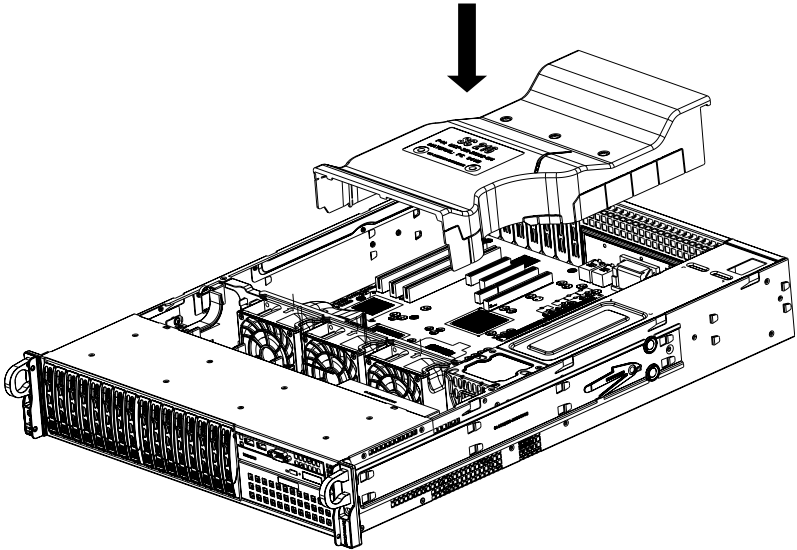

**Figure 4-15. Installing the Main Air Shroud**

### ***Installing the Main Air Shroud***

1. Lay the chassis on a flat, stable surface and remove the chassis cover.
2. If necessary, move any cables that interfere with the air shroud placement.
3. Place the air shroud in the chassis. The air shroud fits just behind the three fans in the fan rack. Slide the air shroud into the grooves just behind the fan rack. Note that some serverboards may require the air shroud to be modified to fit over the serverboard. The SC213 air shroud is designed with break-away pieces that may be removed to accommodate differing styles of serverboards.

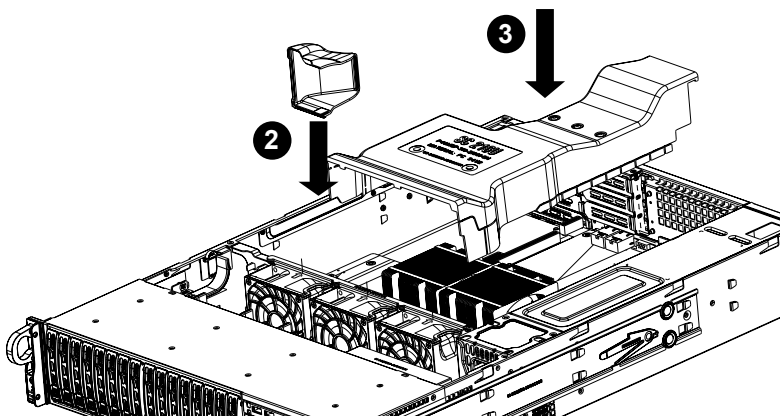

**Figure 4-16. Installing the UIO Model Air Shroud**

An additional air shroud is required for high-powered CPUs, to provide extra cooling. Install the additional air shroud if necessary.

#### ***Installing the UIO Air Shroud***

1. Remove the left side break-away piece of the main air shroud.
2. Slide the additional air shroud into the chassis before installing the main air shroud.
3. Install the main air shroud as directed on the previous page.

## 4-7 Power Supply

The chassis has a redundant power supply. Redundant power supplies are hot-swappable, and can be changed without powering down the system. New units can be ordered directly from Supermicro. Replace a failed power module with the same model.

This power supply is auto-switching capable. This enables it to automatically sense and operate at a 100v to 240v input voltage. An amber light will be illuminated on the power supply when the power is off. An illuminated green light indicates that the power supply is operating.

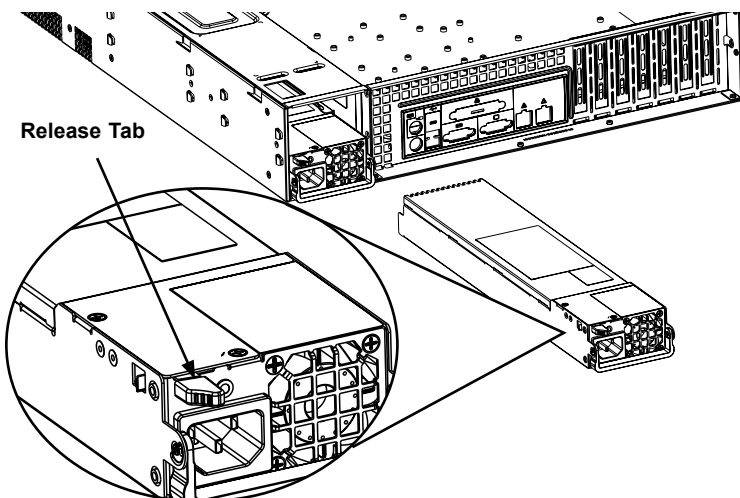

Figure 4-17. Removing the Power Supply

### *Changing the Power Supply*

1. Push the release tab on the back of the power supply module.
2. While holding down the release tab, pull the power supply out using the handle.
3. Push the new power supply module into the power bay until the tab clicks into the locked position.
4. Plug the AC power cord back into the module and the replacement power module will automatically power-up.

## 4-8 Installing the Power Distributor

The power distributor provides failover and power supply redundancy and is pre-installed in the chassis. In the rare event that you have to replace the power distributor, follow the steps below.

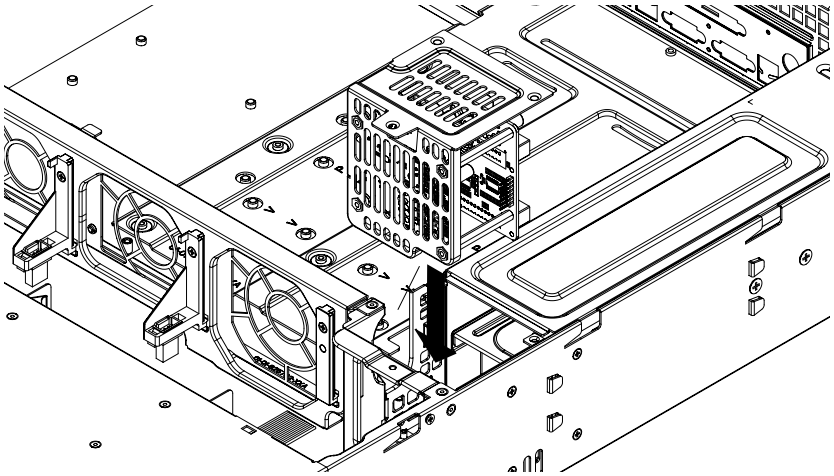

Figure 4-18. Installing the Power Distributor

### *Changing the Power Distributor*

1. Power down the server as describe is Section 4-2.
2. Remove all cable connections to the power supply from the serverboard, backplane, and other components. Also, remove both power supply modules.
3. Remove the screws securing the power distributor.
4. Gently pull the power distributor from the chassis. Gently guide all the cables through the power distributor housing.
5. Slide the new power distributor module into the power distributor housing. Make that you slide the cables through the bottom of the housing.
6. Reconnect all the power cables, replace the power supply, and insert the plug into the wall.

## 4-9 Removing the Backplane

The backplane is located behind the hard drives and in front of the front system fans. In order to change jumper settings on the backplane, it may be necessary to remove the backplane from the chassis.

### *Removing the Backplane from the Chassis*

1. Power down the server as describe is Section 4-2 and remove the chassis cover.
2. Disconnect the cabling to the backplane.
3. Remove all of the hard drives from the drive bays in the front of the chassis
4. Remove the three upper screws at the top of the backplane, indicated by the arrows below.

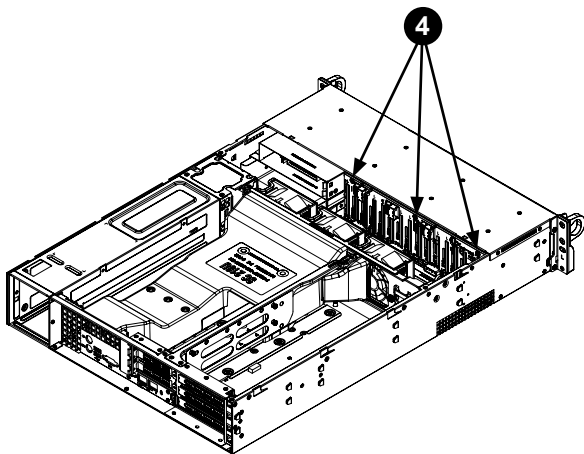

**Figure 4-19. Removing the Screws at the Top of the Backplane**

5. Loosen but do not remove the three screws in the spring bar, located on the floor of the chassis, indicated by the arrows below.

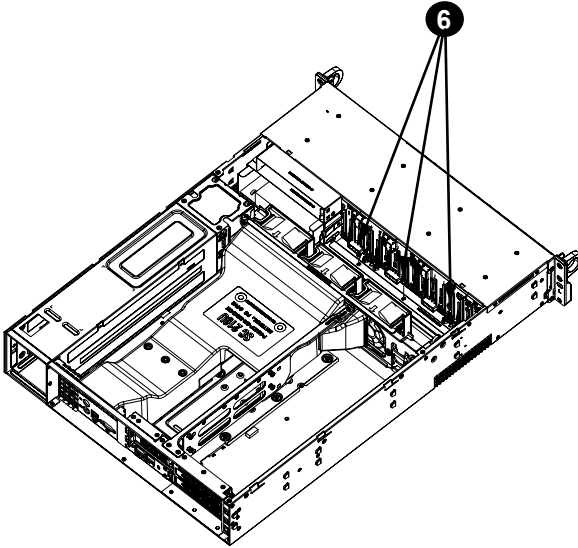

**Figure 4-20. Loosening the Spring Bar Screws in the Floor of the Chassis**

6. Gently ease the backplane up and out of the chassis.

#### ***Installing the Backplane into the Chassis***

1. Ensure that all of the hard drive trays have been removed from the bays in the front of the chassis and that the spring bar has been loosened as directed in the previous section.
2. Slide the backplane into the chassis at a slight angle, pushing it up against the side of the chassis.
3. Ease the backplane forward, against the front of the chassis. This will aid in the alignment of the mounting holes.
4. Align the mounting holes in the backplane with the holes in the chassis. Replace the three screws at the top of the backplane and the three screws in the floor of the chassis.
5. Reconnect all cables and return the hard drive trays to their bays in the front of the chassis.

## Appendix A

### SC213 Power Supply Specifications

This appendix lists power supply specifications for your chassis system.

<b>920W (Redundant)</b>	
<b>MFR Part #</b>	PWS-920P-1R
<b>AC Input</b>	100-240 V, 50-60 Hz, 11-4.5 Amp
<b>DC Output</b>	4 Amp @ +5V standby 75 Amp @ +12V



<b>740W (Redundant)</b>	
<b>MFR Part #</b>	PWS-741P-1R
<b>AC Input</b>	100-240 V, 50-60 Hz, 9-3.5 Amp
<b>DC Output</b>	4 Amp @ +5V standby 61.7 Amp @ +12V
<b>DC Output with PDB</b>	+5V: 45 Amp +3.3V: 24 Amp -12V: 0.6 Amp



<b>720W (Redundant)</b>	
<b>MFR Part #</b>	PWS-721P-1R
<b>AC Input</b>	100-240 V, 50-60 Hz, 4-9 Amp
<b>DC Output</b>	3 Amp @ +5V standby 59 Amp @ +12V
<b>DC Output with PDB</b>	+12V/75A; +5Vsb/4A



<b>900W (Redundant)</b>	
<b>MFR Part #</b>	PWS-902-1R
<b>AC Input</b>	100 - 240V, 60-50Hz, 11-4.5 Amp
<b>DC Output</b>	+5V standby 4 Amp +12V 75 Amp
<b>DC Output with PDB</b>	+5V: 45 Amp +3.3V: 24 Amp -12V: 0.6 AmpVsb/4A

<b>1200W (Redundant)</b>	
<b>MFR Part #</b>	PWS-1K23A-1R
<b>AC Input</b>	100 - 127V, 60-50Hz, 15-12 Amps 200 - 240V, 60-50Hz, 8.5-7 Amps
<b>DC Output</b>	1000 W, +12V, 83 Amps (input 100-127 Vac) 1200 W, +12V, 100 Amps (input 200-240 Vac) +5V standby 4 Amp





## Appendix B

# Standardized Warning Statements for AC Systems

### About Standardized Warning Statements

The following statements are industry standard warnings, provided to warn the user of situations which have the potential for bodily injury. Should you have questions or experience difficulty, contact Supermicro's Technical Support department for assistance. Only certified technicians should attempt to install or configure components.

Read this appendix in its entirety before installing or configuring components in the Supermicro chassis.

These warnings may also be found on our website at [http://www.supermicro.com/about/policies/safety\\_information.cfm](http://www.supermicro.com/about/policies/safety_information.cfm).

### Warning Definition



**Warning!** This warning symbol means danger. You are in a situation that could cause bodily injury. Before you work on any equipment, be aware of the hazards involved with electrical circuitry and be familiar with standard practices for preventing accidents.

#### 警告の定義

この警告サインは危険を意味します。

人身事故につながる可能性がありますので、いずれの機器でも動作させる前に、電気回路に含まれる危険性に注意して、標準的な事故防止策に精通して下さい。

此警告符号代表危 。

您正处于可能受到 重 害的工作环境中。在您使用 始工作之前，必 充分意 到触 的危 ，并熟 掌握防止事故 生的 准工作程序。 根据每 警告 尾的声明号 找到此 的安全性警告 明的翻 文本。

此警告符號代表危險。

您目前所處的工作環境可能讓您受傷。的工作環境中。在您使用任何設備之前，請注意觸電的危險，並且要熟悉預防事故發生的標準工作程序。請依照每一注意事項後的號碼找到相關的翻譯說明內容。

## Warnung

## WICHTIGE SICHERHEITSHINWEISE

Dieses Warnsymbol bedeutet Gefahr. Sie befinden sich in einer Situation, die zu Verletzungen führen kann. Machen Sie sich vor der Arbeit mit Geräten mit den Gefahren elektrischer Schaltungen und den üblichen Verfahren zur Vorbeugung vor Unfällen vertraut. Suchen Sie mit der am Ende jeder Warnung angegebenen Anweisungsnummer nach der jeweiligen Übersetzung in den übersetzten Sicherheitshinweisen, die zusammen mit diesem Gerät ausgeliefert wurden.

BEWAHREN SIE DIESE HINWEISE GUT AUF.

## INSTRUCCIONES IMPORTANTES DE SEGURIDAD

Este símbolo de aviso indica peligro. Existe riesgo para su integridad física. Antes de manipular cualquier equipo, considere los riesgos de la corriente eléctrica y familiarícese con los procedimientos estándar de prevención de accidentes. Al final de cada advertencia encontrará el número que le ayudará a encontrar el texto traducido en el apartado de traducciones que acompaña a este dispositivo.

GUARDE ESTAS INSTRUCCIONES.

## IMPORTANTES INFORMATIONS DE SÉCURITÉ

Ce symbole d'avertissement indique un danger. Vous vous trouvez dans une situation pouvant entraîner des blessures ou des dommages corporels. Avant de travailler sur un équipement, soyez conscient des dangers liés aux circuits électriques et familiarisez-vous avec les procédures couramment utilisées pour éviter les accidents. Pour prendre connaissance des traductions des avertissements figurant dans les consignes de sécurité traduites qui accompagnent cet appareil, référez-vous au numéro de l'instruction situé à la fin de chaque avertissement.

CONSERVEZ CES INFORMATIONS.

**תקנון הזהרות אזהרה**

הזהרות הבאות הן אזהרות על פי תקני התעשייה, על מנת להזהיר את המשתמש מפני חבלה פיזית אפשרית. במידה ויש שאלות או היתקלות בבעיה כלשהי, יש ליצור קשר עם מחלקת תמיכה טכנית של סופרמיקרו. טכנאים מוסמכים בלבד רשאים להתקין או להגדיר את הרכיבים.

יש לקרוא את הנספח במלואו לפני התקנת או הגדרת הרכיבים במארזי סופרמיקרו.

تحذير! هذا الرمز يعني خطر انك في حالة يمكن أن تتسبب في اصابة جسدية .  
 قبل أن تعمل على أي معدات، كن على علم بالمخاطر الناجمة عن الدوائر  
 الكهربائية  
 وكن على دراية بالممارسات الوقائية لمنع وقوع أي حوادث  
 استخدم رقم البيان المنصوص في نهاية كل تحذير للعثور ترجمتها

안전을 위한 주의사항

경고!

이 경고 기호는 위험이 있음을 알려 줍니다. 작업자의 신체에 부상을 야기 할 수 있는  
 상태에 있게 됩니다. 모든 장비에 대한 작업을 수행하기 전에 전기회로와 관련된  
 위험요소들을 확인하시고 사전에 사고를 방지할 수 있도록 표준 작업절차를 준수해 주시기  
 바랍니다.

해당 번역문을 찾기 위해 각 경고의 마지막 부분에 제공된 경고문 번호를 참조하십시오

## BELANGRIJKE VEILIGHEIDSINSTRUCTIES

Dit waarschuwings symbool betekent gevaar. U verkeert in een situatie die lichamelijk letsel kan veroorzaken. Voordat u aan enige apparatuur gaat werken, dient u zich bewust te zijn van de bij een elektrische installatie betrokken risico's en dient u op de hoogte te zijn van de standaard procedures om ongelukken te voorkomen. Gebruik de nummers aan het eind van elke waarschuwing om deze te herleiden naar de desbetreffende locatie.

BEWAAR DEZE INSTRUCTIES

## Installation Instructions



**Warning!** Read the installation instructions before connecting the system to the power source.

### 設置手順書

システムを電源に接続する前に、設置手順書をお読み下さい。

### 警告

将此系 接 源前，先 安 明。

### 警告

將系統與電源連接前，請先閱讀安裝說明。

Warnung

Vor dem Anschließen des Systems an die Stromquelle die Installationsanweisungen lesen.

¡Advertencia!

Lea las instrucciones de instalación antes de conectar el sistema a la red de alimentación.

Attention

Avant de brancher le système sur la source d'alimentation, consulter les directives d'installation.

יש לקרוא את הוראות התקנה לפני חיבור המערכת למקור מתח.

اقر إرشادات التركيب قبل توصيل النظام إلى مصدر للطاقة

시스템을 전원에 연결하기 전에 설치 안내를 읽어주십시오.

Waarschuwing

Raadpleeg de installatie-instructies voordat u het systeem op de voedingsbron aansluit.

### Circuit Breaker



**Warning!** This product relies on the building's installation for short-circuit (overcurrent) protection. Ensure that the protective device is rated not greater than: 250 V, 20 A.

サーキット・ブレーカー

この製品は、短絡(過電流)保護装置がある建物での設置を前提としています。

保護装置の定格が250 V、20 Aを超えないことを確認下さい。

警告

此产品的短路(过流)保护由建筑物的供电系统提供,确保短路保护的额定电流不大于250V,20A。

警告

此产品的短路(过载电流)保护由建筑物的供电系统提供,确保短路保护设备的额定电流不大于250V,20A。

### Warnung

Dieses Produkt ist darauf angewiesen, dass im Gebäude ein Kurzschluss- bzw. Überstromschutz installiert ist. Stellen Sie sicher, dass der Nennwert der Schutzvorrichtung nicht mehr als: 250 V, 20 A beträgt.

### ¡Advertencia!

Este equipo utiliza el sistema de protección contra cortocircuitos (o sobrecorrientes) del edificio. Asegúrese de que el dispositivo de protección no sea superior a: 250 V, 20 A.

### Attention

Pour ce qui est de la protection contre les courts-circuits (surtension), ce produit dépend de l'installation électrique du local. Vérifiez que le courant nominal du dispositif de protection n'est pas supérieur à :250 V, 20 A.

מוצר זה מסתמך על הגנה המותקנת במבנים למניעת קצר חשמלי. יש לוודא כי המכשיר המגן מפני הקצר החשמלי הוא לא יותר מ-250 V, 20 A

المنتج يعتمد على معدات الحماية من الدوائر القصيرة التي تم تثبيتها في  
بنى  
أكبر من أن تقبل الحماية المقابلة. ليس أكثر من 250V 20A

### 경고!

이 제품은 전원의 단락(과전류)방지에 대해서 전적으로 건물의 관련 설비에 의존합니다. 보호장치의 정격이 반드시 250V(볼트), 20A(암페어)를 초과하지 않도록 해야 합니다.

### Waarschuwing

Dit product is afhankelijk van de kortsluitbeveiliging (overspanning) van uw elektrische installatie. Controleer of het beveiligde apparaat niet groter gedimensioneerd is dan 250V, 20A.

## Power Disconnection Warning



**Warning!** The system must be disconnected from all sources of power and the power cord removed from the power supply module(s) before accessing the chassis interior to install or remove system components.

### 電源切斷の警告

システムコンポーネントの取り付けまたは取り外しのために、シャーシ内部にアクセスするには、システムの電源はすべてのソースから切斷され、電源コードは電源モジュールから取り外す必要があります。

### 警告

在你打 机箱并安 或移除内部器件前,必 将系 完全断 ,并移除 源 。

### 警告

在您打開機殼安裝或移除內部元件前，必須將系統完全斷電，並移除電源線。

### Warnung

Das System muss von allen Quellen der Energie und vom Netzanschlusskabel getrennt sein, das von den Spg.Versorgungsteilmodulen entfernt wird, bevor es auf den Chassisinnenraum zurückgreift, um Systemsbestandteile anzubringen oder zu entfernen.

### ¡Advertencia!

El sistema debe ser disconnected de todas las fuentes de energía y del cable eléctrico quitado de los módulos de fuente de alimentación antes de tener acceso el interior del chasis para instalar o para quitar componentes de sistema.

### Attention

Le système doit être débranché de toutes les sources de puissance ainsi que de son cordon d'alimentation secteur avant d'accéder à l'intérieur du chasis pour installer ou enlever des composants de système.

## אזהרה מפני ניתוק חשמלי

### אזהרה!

יש לנתק את המערכת מכל מקורות החשמל ויש להסיר את כבל החשמלי מהספק לפני גישה לחלק הפנימי של המארז לצורך התקנת או הסרת רכיבים.

يجب فصل النظام من جميع مصادر الطاقة وإزالة سلك الكهرباء من وحدة امداد  
الطاقة قبل  
الوصول إلى المناطق الداخلية للهيكل لتثبيت أو إزالة مكونات الجهاز

경고!

시스템에 부품들을 장착하거나 제거하기 위해서는 새시 내부에 접근하기 전에 반드시 전원 공급장치로부터 연결되어있는 모든 전원과 전기코드를 분리해주어야 합니다.

Waarschuwing

Voordat u toegang neemt tot het binnenwerk van de behuizing voor het installeren of verwijderen van systeem onderdelen, dient u alle spanningsbronnen en alle stroomkabels aangesloten op de voeding(en) van de behuizing te verwijderen

## Equipment Installation



**Warning!** Only trained and qualified personnel should be allowed to install, replace, or service this equipment.

機器の設置

トレーニングを受け認定された人だけがこの装置の設置、交換、またはサービスを許可されてい  
ます。

警告

只有 过培 且具有 格的人 才能 行此 的安 、更 和 修。

警告

只有經過受訓且具資格人員才可安裝、更換與維修此設備。

Warnung

Das Installieren, Ersetzen oder Bedienen dieser Ausrüstung sollte nur geschultem, qualifiziertem Personal gestattet werden.

¡Advertencia!

Solamente el personal calificado debe instalar, reemplazar o utilizar este equipo.

**Attention**

Il est vivement recommandé de confier l'installation, le remplacement et la maintenance de ces équipements à des personnels qualifiés et expérimentés.

**אזהרה!**  
צוות מוסמך בלבד רשאי להתקין, להחליף את הציוד או לתת שירות עבור הציוד.

يجب أن يسمح فقط للموظفين المؤهلين والمدربين لتركيب واستبدال أو خدمة هذا الجهاز

경고!

훈련을 받고 공인된 기술자만이 이 장비의 설치, 교체 또는 서비스를 수행할 수 있습니다.

**Waarschuwing**

Deze apparatuur mag alleen worden geïnstalleerd, vervangen of hersteld door geschoold en gekwalificeerd personeel.

**Restricted Area**

**Warning!** This unit is intended for installation in restricted access areas. A restricted access area can be accessed only through the use of a special tool, lock and key, or other means of security. (This warning does not apply to workstations).

**アクセス制限区域**

このユニットは、アクセス制限区域に設置されることを想定しています。

アクセス制限区域は、特別なツール、鍵と錠前、その他のセキュリティの手段を用いてのみ出入りが可能です。

警告

此部件 安 在限制 出的 所，限制 出的 所指只能通过使用特殊工具、和 匙或其它安全手段 出的 所。

警告

此裝置僅限安裝於進出管制區域，進出管制區域係指僅能以特殊工具、鎖頭及鑰匙或其他安全方式才能進入的區域。



### Warnung

Diese Einheit ist zur Installation in Bereichen mit beschränktem Zutritt vorgesehen. Der Zutritt zu derartigen Bereichen ist nur mit einem Spezialwerkzeug, Schloss und Schlüssel oder einer sonstigen Sicherheitsvorkehrung möglich.

### ¡Advertencia!

Esta unidad ha sido diseñada para instalación en áreas de acceso restringido. Sólo puede obtenerse acceso a una de estas áreas mediante la utilización de una herramienta especial, cerradura con llave u otro medio de seguridad.

### Attention

Cet appareil doit être installée dans des zones d'accès réservés. L'accès à une zone d'accès réservé n'est possible qu'en utilisant un outil spécial, un mécanisme de verrouillage et une clé, ou tout autre moyen de sécurité.

### אזור עם גישה מוגבלת

#### אזהרה!

יש להתקין את היחידה באזורים שיש בהם הגבלת גישה. הגישה ניתנת בעזרת כלי אבטחה בלבד (מפתח, מנעול וכד').

تم تخصيص هذه الوحدة لت تركيبها في مناطق محظورة .  
يمكن الوصول إلى منطقة محظورة فقط من خلال استخدام أداة خاصة،  
قفل ومفتاح أو أي وسيلة أخرى للأمان

### 경고!

이 장치는 접근이 제한된 구역에 설치하도록 되어있습니다. 특수도구, 잠금 장치 및 키, 또는 기타 보안 수단을 통해서만 접근 제한 구역에 들어갈 수 있습니다.

### Waarschuwing

Dit apparaat is bedoeld voor installatie in gebieden met een beperkte toegang. Toegang tot dergelijke gebieden kunnen alleen verkregen worden door gebruik te maken van speciaal gereedschap, slot en sleutel of andere veiligheidsmaatregelen.

## Battery Handling



**Warning!** There is the danger of explosion if the battery is replaced incorrectly. Replace the battery only with the same or equivalent type recommended by the manufacturer. Dispose of used batteries according to the manufacturer's instructions

### 電池の取り扱い

電池交換が正しく行われなかった場合、破裂の危険性があります。交換する電池はメーカーが推奨する型、または同等のものを使用下さい。使用済電池は製造元の指示に従って処分して下さい。

### 警告

池更 不当会有爆炸危 。 只使用同类 池或制造商推荐的功能相当的 池更 原有池 。 按制造商的 明处理 旧 池 。

### 警告

電池更換不當會有爆炸危險。請使用製造商建議之相同或功能相當的電池更換原有電池。請按照製造商的說明指示處理廢棄舊電池。

### Warnung

Bei Einsetzen einer falschen Batterie besteht Explosionsgefahr. Ersetzen Sie die Batterie nur durch den gleichen oder vom Hersteller empfohlenen Batterietyp. Entsorgen Sie die benutzten Batterien nach den Anweisungen des Herstellers.

### Attention

Danger d'explosion si la pile n'est pas remplacée correctement. Ne la remplacer que par une pile de type semblable ou équivalent, recommandée par le fabricant. Jeter les piles usagées conformément aux instructions du fabricant.

### ¡Advertencia!

Existe peligro de explosión si la batería se reemplaza de manera incorrecta. Reemplazar la batería exclusivamente con el mismo tipo o el equivalente recomendado por el fabricante. Desechar las baterías gastadas según las instrucciones del fabricante.

### אזהרה!

קיימת סכנת פיצוץ של הסוללה במידה והוחלפה בדרך לא תקינה. יש להחליף את הסוללה בסוג התואם מחברת יצרן מומלצת.

סילוק הסוללות המשומשות יש לבצע לפי הוראות היצרן.

هناك خطر من انفجار في حالة استبدال البطارية بطريقة غير صحيحة فعليك  
استبدال البطارية  
فقط بنفس النوع أو ما يعادلها كما أوصت به الشركة المصنعة  
تخلص من البطاريات المستعملة وفقا لتعليمات الشركة الصانعة

경고!

배터리가 올바르게 교체되지 않으면 폭발의 위험이 있습니다. 기존 배터리와 동일하거나 제조사에서 권장하는 동등한 종류의 배터리로만 교체해야 합니다. 제조사의 안내에 따라 사용된 배터리를 처리하여 주십시오.

Waarschuwing

Er is ontplofingsgevaar indien de batterij verkeerd vervangen wordt. Vervang de batterij slechts met hetzelfde of een equivalent type die door de fabrikant aanbevolen wordt. Gebruikte batterijen dienen overeenkomstig fabrieksvoorschriften afgevoerd te worden.

## Redundant Power Supplies



**Warning!** This unit might have more than one power supply connection. All connections must be removed to de-energize the unit.

冗長電源装置

このユニットは複数の電源装置が接続されている場合があります。

ユニットの電源を切るためには、すべての接続を取り外さなければなりません。

警告

此部件 接的 源可能不止一个，必 将所有 源断 才能停止 部件供 。

警告

此裝置連接的電源可能不只一個，必須切斷所有電源才能停止對該裝置的供電。

Warnung

Dieses Gerät kann mehr als eine Stromzufuhr haben. Um sicherzustellen, dass der Einheit kein Strom zugeführt wird, müssen alle Verbindungen entfernt werden.

¡Advertencia!

Puede que esta unidad tenga más de una conexión para fuentes de alimentación. Para cortar por completo el suministro de energía, deben desconectarse todas las conexiones.

Attention

Cette unité peut avoir plus d'une connexion d'alimentation. Pour supprimer toute tension et tout courant électrique de l'unité, toutes les connexions d'alimentation doivent être débranchées.

**אם קיים יותר מספק אחד**

**אזהרה !**

ליחידה יש יותר מחיבור אחד של ספק. יש להסיר את כל החיבורים על מנת לרוקן את היחידה.

قد يكون لهذا الجهاز عدة اتصالات بوحدات امداد الطاقة.  
يجب إزالة كافة الاتصالات لعزل الوحدة عن الكهرباء.

경고!

이 장치에는 한 개 이상의 전원 공급 단자가 연결되어 있을 수 있습니다. 이 장치에 전원을 차단하기 위해서는 모든 연결 단자를 제거해야만 합니다.

Waarschuwing

Deze eenheid kan meer dan één stroomtoevoeraansluiting bevatten. Alle aansluitingen dienen verwijderd te worden om het apparaat stroomloos te maken.

## Backplane Voltage



**Warning!** Hazardous voltage or energy is present on the backplane when the system is operating. Use caution when servicing.

### バックプレーンの電圧

システムの稼働中は危険な電圧または電力が、バックプレーン上にかかっています。

修理する際には注意ください。

### 警告

当系 正在 行时，背板上有很危 的 压或能量， 行 修时 必小心。

### 警告

當系統正在進行時，背板上有很危險的電壓或能量，進行維修時務必小心。

### Warnung

Wenn das System in Betrieb ist, treten auf der Rückwandplatine gefährliche Spannungen oder Energien auf. Vorsicht bei der Wartung.

### ¡Advertencia!

Cuando el sistema está en funcionamiento, el voltaje del plano trasero es peligroso. Tenga cuidado cuando lo revise.

### Attention

Lorsque le système est en fonctionnement, des tensions électriques circulent sur le fond de panier. Prendre des précautions lors de la maintenance.

## מתח בפנל האחורי

אזהרה!  
קיימת סכנת מתח בפנל האחורי בזמן תפעול המערכת. יש להיזהר במהלך העבודה.

هناك خطر من التيار الكهربائي أو الطاقة الموجودة على اللوحة  
عندما يكون النظام يعمل كن حذرا عند خدمة هذا الجهاز

경고!

시스템이 동작 중일 때 후면판 (Backplane)에는 위험한 전압이나 에너지가 발생 합니다.  
서비스 작업 시 주의하십시오.

Waarschuwing

Een gevaarlijke spanning of energie is aanwezig op de backplane wanneer het systeem in gebruik is. Voorzichtigheid is geboden tijdens het onderhoud.

## Comply with Local and National Electrical Codes



**Warning!** Installation of the equipment must comply with local and national electrical codes.

地方および国の電気規格に準拠

機器の取り付けはその地方および国の電気規格に準拠する必要があります。

警告

安 必 符合本地与本国 气法 。

警告

設備安裝必須符合本地與本國電氣法規。

Warnung

Die Installation der Geräte muss den Sicherheitsstandards entsprechen.

¡Advertencia!

La instalacion del equipo debe cumplir con las normas de electricidad locales y nacionales.

Attention

L'équipement doit être installé conformément aux normes électriques nationales et locales.

## תיאום חוקי החשמל הארצי

אזהרה!  
התקנת הציוד חייבת להיות תואמת לחוקי החשמל המקומיים והארציים.

تركيب المعدات الكهربائية يجب أن يمتثل للقوانين المحلية والوطنية المتعلقة  
بالكهرباء

경고!

현 지역 및 국가의 전기 규정에 따라 장비를 설치해야 합니다.

Waarschuwing

Bij installatie van de apparatuur moet worden voldaan aan de lokale en nationale elektriciteitsvoorschriften.

## Product Disposal



**Warning!** Ultimate disposal of this product should be handled according to all national laws and regulations.

製品の廃棄

この製品を廃棄処分する場合、国の関係する全ての法律・条例に従い処理する必要があります。

警告

本产品的弃处理 根据所有国家的法律和 章 行。

警告

本產品的廢棄處理應根據所有國家的法律和規章進行。

Warnung

Die Entsorgung dieses Produkts sollte gemäß allen Bestimmungen und Gesetzen des Landes erfolgen.

¡Advertencia!

Al deshacerse por completo de este producto debe seguir todas las leyes y reglamentos nacionales.

## Attention

La mise au rebut ou le recyclage de ce produit sont généralement soumis à des lois et/ou directives de respect de l'environnement. Renseignez-vous auprès de l'organisme compétent.

## סילוק המוצר

אזהרה!

סילוק סופי של מוצר זה חייב להיות בהתאם להנחיות וחוקי המדינה.

عند التخلص النهائي من هذا المنتج ينبغي التعامل معه وفقا لجميع القوانين واللوائح الوطنية

## 경고!

이 제품은 해당 국가의 관련 법규 및 규정에 따라 폐기되어야 합니다.

## Waarschuwing

De uiteindelijke verwijdering van dit product dient te geschieden in overeenstemming met alle nationale wetten en reglementen.

## Hot Swap Fan Warning



**Warning!** Hazardous moving parts. Keep away from moving fan blades. The fans might still be turning when you remove the fan assembly from the chassis. Keep fingers, screwdrivers, and other objects away from the openings in the fan assembly's housing.

## ファン・ホットスワップの警告

警告!回転部品に注意。運転中は回転部(羽根)に触れないでください。シャーシから冷却ファン装置を取り外した際、ファンがまだ回転している可能性があります。ファンの開口部に、指、ドライバー、およびその他のものを近づけないで下さい。

## 警告!

警告! 危 的可移动性零件。 必与 动的 扇叶片保持距离。 当您从机架移除 扇 置, 扇可能仍在 动。小心不要将手指、螺 起子和其他物品太靠近 扇

## 警告

危險的可移動性零件。請務必與轉動的風扇葉片保持距離。 當您從機架移除風扇裝置, 風扇可能仍在轉動。小心不要將手指、螺絲起子和其他物品太靠近風扇。



**Warnung**

Gefährlich Bewegende Teile. Von den bewegenden Lüfterblätter fern halten. Die Lüfter drehen sich u. U. noch, wenn die Lüfterbaugruppe aus dem Chassis genommen wird. Halten Sie Finger, Schraubendreher und andere Gegenstände von den Öffnungen des Lüftergehäuses entfernt.

**¡Advertencia!**

Riesgo de piezas móviles. Mantener alejado de las aspas del ventilador. Los ventiladores podran dar vuelta cuando usted quite el montaje del ventilador del chasis. Mantenga los dedos, los destornilladores y todos los objetos lejos de las aberturas del ventilador

**Attention**

Pieces mobiles dangereuses. Se tenir a l'écart des lames du ventilateur Il est possible que les ventilateurs soient toujours en rotation lorsque vous retirerez le bloc ventilateur du châssis. Prenez garde à ce que doigts, tournevis et autres objets soient éloignés du logement du bloc ventilateur.

**אזהרה!**

כאשר מסירים את חלקי המאוורר מהמארז, יתכן והמאווררים עדיין עובדים. יש להרחיק למרחק בטוח את האצבעות וכלי עבודה שונים מהפתחים בתוך המאוורר

من الممكن أن المراوح لا تزال تدور عند إزالة كتلة المروحة من الهيكل يجب إبقاء الأصابع ومفكات البراغي  
بعيداً عن الأشياء بعداً عن الفتحات من كتلة المروحة

**경고!**

움직이는 위험한 부품. 회전하는 송풍 날개에 접근하지 마세요. 새시로부터 팬 조립품을 제거할 때 팬은 여전히 회전하고 있을 수 있습니다. 팬 조립품 외관의 열려있는 부분들로부터 손가락 및 스크류드라이버, 다른 물체들이 가까이 하지 않도록 배치해 주십시오.

**Waarschuwing**

Gevaarlijk bewegende onderdelen. Houd voldoende afstand tot de bewegende ventilatorbladen. Het is mogelijk dat de ventilator nog draait tijdens het verwijderen van het ventilatorsamenstel uit het chassis. Houd uw vingers, schroevendraaiers en eventuele andere voorwerpen uit de buurt van de openingen in de ventilatorbehuizing.

## Power Cable and AC Adapter



**Warning!** When installing the product, use the provided or designated connection or procure cables, power cables and AC adaptors complying with local codes and safety requirements including proper cord size and plug. Using any other cables and adaptors could cause a malfunction or a fire. Electrical Appliance and Material Safety Law prohibits the use of UL or CSA -certified cables (that have UL/CSA shown on the code) for any other electrical devices than products designated by Supermicro only.

### 電源コードとACアダプター

製品を設置する場合、提供または指定および購入された接続ケーブル、電源コードとACアダプターを該当する地域の条例や安全基準に適合するコードサイズやプラグと共に使用下さい。他のケーブルやアダプタを使用すると故障や火災の原因になることがあります。

電気用品安全法は、ULまたはCSA認定のケーブル(UL/CSEマークがコードに表記)を Supermicro が指定する製品以外に使用することを禁止しています。

### 警告

安此品時、使用本身提供的或指定的或采的接、源和源适配器、包含遵照当地法和安全要求的合的源尺寸和插头.使用其它材或适配器可能会引起故障或火灾。除了Supermicro所指定的品、气用品和材料安全法律定禁止使用未UL或CSA的材。(材上会示UL/CSA符号)。

### 警告

安裝此產品時，請使用本身提供的或指定的或採購的連接線，電源線和電源適配器，包含遵照當地法規和安全要求的合規的電源線尺寸和插頭.使用其它線材或適配器可能會引起故障或火災。除了Supermicro所指定的產品，電氣用品和材料安全法律規定禁止使用未經UL或CSA認證的線材。(線材上會顯示UL/CSA符號)。

### Warnung

Nutzen Sie beim Installieren des Produkts ausschließlich die von uns zur Verfügung gestellten Verbindungskabeln, Stromkabeln und/oder Adapter, die Ihre örtlichen Sicherheitsstandards einhalten. Der Gebrauch von anderen Kabeln und Adapter können Fehlfunktionen oder Feuer verursachen. Die Richtlinien untersagen das Nutzen von UL oder CAS zertifizierten Kabeln (mit UL/CSA gekennzeichnet), an Geräten oder Produkten die nicht mit Supermicro gekennzeichnet sind.

### ¡Advertencia!

Cuando instale el producto, utilice la conexión provista o designada o procure cables, Cables de alimentación y adaptadores de CA que cumplan con los códigos locales y los requisitos de seguridad, incluyendo el tamaño adecuado del cable y el enchufe. El uso de otros cables y adaptadores podría causar un mal funcionamiento o un incendio. La Ley de Seguridad de Aparatos Eléctricos y de Materiales prohíbe El uso de cables certificados por UL o CSA (que tienen el certificado UL / CSA en el código) para cualquier otros dispositivos eléctricos que los productos designados únicamente por Supermicro.

### Attention

Lors de l'installation du produit, utilisez les cables de connection fournis ou désigné ou achetez des cables, cables de puissance et adaptateurs respectant les normes locales et les conditions de securite y compris les tailles de cables et les prises electriques appropries. L'utilisation d'autres cables et adaptateurs peut provoquer un dysfonctionnement ou un incendie. Appareils électroménagers et la Loi sur la Sécurité Matériel interdit l'utilisation de câbles certifiés- UL ou CSA (qui ont UL ou CSA indiqué sur le code) pour tous les autres appareils électriques sauf les produits désignés par Supermicro seulement.

AC ימאתמו מיילמשח מילבכ

!הרהזא

ךרוצל ומאתוה וא ושכרנ רשא AC מימאתמו מיקפס, מילבכב שמתשהל שי, רצומה תא מיניקתמ רשאכ לכב שומיש . עקתהו לבכה לש הנוכח הדימ ללוכ, תוימוקמה תוחיטבה תושירדל ומאתוה רשאו, הנקתהה למשחה ירישכמב שומישה יקוחל מאתהב. ילמשח רצק וא הלקתל מורגל לולע, רחא גוסמ מאתמ וא לבכ לש דוק מהילע עיפומ רשאכ) UL-ב או CSA-ב -ב מיכמומה מילבכב שמתשהל רוסיא מייק, תוחיטבה יקוחו דבלב Supermicro י"ע מאתוה רשא רצומב קר אלא, רחא ילמשח רצומ לכ רובע (UL/CSA)

תאלבאלא אארשב מץ וא אדדחמלא וא ארפוטמלא תאליטוטלא מאדחטסאב מץ, אגתנמלא בייקרת דנע לכלז יפ אמב אילחמלא אלאסלא תאבלטתמו נינאווקב מאזתלאלא אמ דדרתמלא ראיטלא תאלוחמו אילברמלא קיירח וא לטע יפ בבסטטי דץ ירשא תאלוחמו תאלבאלא יא מאדחטסא. מילסלא סבאלאו ולסומלא מץ ח CSA וא UL לביק נמ אדמתמלא תאלבאלא מאדחטסא תאדעמלא אילברמלא אזהאלל אלאסלא נונאק רזחיי Supermicro לביק נמ אדדחמלא אילברמלא תאגתנמלא רייג ירשא תאדעמ יא אמ (UL/CSA) אלאע למחתיטלאו

### 전원 케이블 및 AC 어댑터

경고! 제품을 설치할 때 현지 코드 및 적절한 굵기의 코드와 플러그를 포함한 안전 요구 사항을 준수하여 제공되거나 지정된 연결 혹은 구매 케이블, 전원 케이블 및 AC 어댑터를 사용하십시오.

다른 케이블이나 어댑터를 사용하면 오작동이나 화재가 발생할 수 있습니다. 전기 용품 안전법은 UL 또는 CSA 인증 케이블 (코드에 UL / CSA가 표시된 케이블)을 Supermicro가 지정한 제품 이외의 전기 장치에 사용하는 것을 금지합니다.

### Stroomkabel en AC-Adapter

Waarschuwing! Bij het aansluiten van het Product uitsluitend gebruik maken van de geleverde Kabels of een andere geschikte aan te schaffen Aansluitmethode, deze moet altijd voldoen aan de lokale voorschriften en veiligheidsnormen, inclusief de juiste kabeldikte en stekker. Het gebruik van niet geschikte Kabels en/of Adapters kan een storing of brand veroorzaken. Wetgeving voor Elektrische apparatuur en Materiaalveiligheid verbied het gebruik van UL of CSA -gecertificeerde Kabels (met UL/CSA in de code) voor elke andere toepassing dan de door Supermicro hiervoor beoogde Producten.

## Appendix C

### BPN-SAS-213A Backplane Specifications

To avoid personal injury and property damage, carefully follow all the safety steps listed below when accessing your system or handling the components.

#### C-1 ESD Safety Guidelines

Electrostatic Discharge (ESD) can damage electronic components. To prevent damage to your system, it is important to handle it very carefully. The following measures are generally sufficient to protect your equipment from ESD.

- Use a grounded wrist strap designed to prevent static discharge.
- Touch a grounded metal object before removing a component from the antistatic bag.
- Handle the backplane by its edges only; do not touch its components, peripheral chips, memory modules or gold contacts.
- When handling chips or modules, avoid touching their pins.
- Put the card and peripherals back into their antistatic bags when not in use.

#### C-2 General Safety Guidelines

- Always disconnect power cables before installing or removing any components from the computer, including the backplane.
- Disconnect the power cable before installing or removing any cables from the backplane.
- Make sure that the backplane is securely and properly installed on the motherboard to prevent damage to the system due to power shortage.

## **C-3 Version Information**

The BPN-SAS-213A backplane has been designed to utilize the most up-to-date technology available, providing your system with reliable, high-quality performance.

This manual reflects BPN-SAS-213A Revision 1.00, the most current release available at the time of publication. Always refer to the Supermicro Web site at [www.supermicro.com](http://www.supermicro.com) for the latest updates, compatible parts and supported configurations.

## C-4 Rear Connectors and Jumpers

The following connectors are on the side of the backplane that faces the rear of the chassis. They are marked by silkscreen labels.

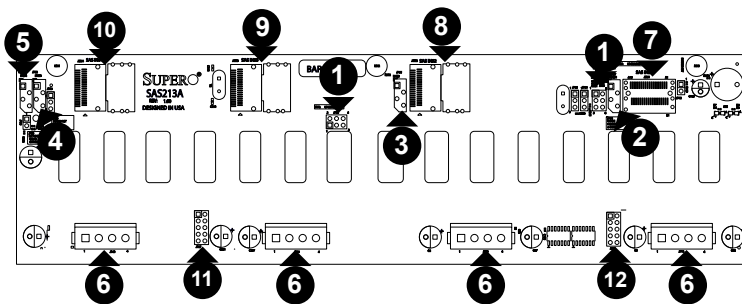

Figure C-1. Rear Connectors and Jumpers

### Rear Connectors

- |   |                          |
|---|--------------------------|
| 1. Upgrade Connectors JP69 and JP78                 | 7. SAS IN#1 JSM1         |
| 2. I <sup>2</sup> C Connector #1 (JP37)             | 8. SAS IN#2 JSM2         |
| 3. I <sup>2</sup> C Connector #2 (JP95)             | 9. SAS IN#3 JSM3         |
| 4. I <sup>2</sup> C Connector #3 (JP52)             | 10. SAS IN#4 JSM4        |
| 5. I <sup>2</sup> C Connector #4 (JP96)             | 11. JP27 Activity LED #2 |
| 6. Power Connectors (4-pin): JP10, JP13, JP46, JP48 | 12. JP26 Activity LED #1 |

## C-5 Rear Connector and Pin Definitions

### 1. Upgrade Connectors

The upgrade connectors are designated JP69, and JP78 are used for manufacturer's diagnostic purposes only.

### 2. - 5. I<sup>2</sup>C Connectors

The I<sup>2</sup>C Connectors, designated JP37, JP95, JP52 and JP96 are used to monitor HDD activity and status. See the table on the right for pin definitions.

I <sup>2</sup> C Connector Pin Definitions	
Pin# Definition	
1	Data
2	Ground
3	Clock
4	No Connection

### 6. Backplane Main Power Connectors

The 4-pin connectors, designated JP10, JP13, JP46 and JP48 provide power to the backplane. See the table on the right for pin definitions.

Backplane Main Power 4-Pin Connector)	
Pin# Definition	
1	+12V
2 and 3	Ground
4	+5V

### 7. - 10. SAS IN Ports (Sideband included)

The SAS ports are used to connect the SAS drive cables. The four SAS IN ports are designated #JSM1 - #JSM4. Each port is also compatible with SATA drives.

Sideband Definitions			
Pin # Definition		Pin # Definition	
A11	<b>SGPIO:</b> SDIN  <b>FC:</b> Backplane Addressing (SB5)	B11	Controller ID (SB6)
A12	<b>SGPIO:</b> SDOUT  <b>FC:</b> Reset (SB4)	B10	GND (SB2)
A9	GND (SB3)	B9	<b>SGPIO:</b> SLOAD  <b>FC:</b> SDA (SB1)
A8	Backplane ID (SB7)	B8	<b>SGPIO:</b> SCLOCK  <b>FC:</b> SCL (SB0)



**11. - 12. ACT\_IN:**

The activity LED connectors, designated JP26, and JP27 are used to indicate the activity status of each SAS drive. The activity LED connector is located on the front panel. For the activity LED connector to work properly, connect using a 10-pin LED cable. This is only used when the activity LED is not supported by the hard drive.

SAS Activity LED Header Pin Definitions			
Pin#	Definition	Pin#	Definition
1	ACT IN#0	6	ACT IN#4
2	ACT IN#1	7	ACT IN#5
3	ACT IN#2	8	ACT IN#6
4	ACT IN#3	9	ACT IN#7
5	Ground	X	Empty

SAS Activity LED Header Pin Definitions			
Pin#	Definition	Pin#	Definition
1	ACT IN#8	6	ACT IN#12
2	ACT IN#9	7	ACT IN#13
3	ACT IN#10	8	ACT IN#14
4	ACT IN#11	9	ACT IN#15
5	Ground	X	Empty

## C-6 Rear Jumper Locations and Pin Definitions

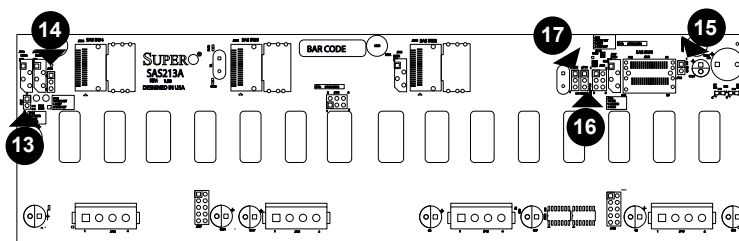
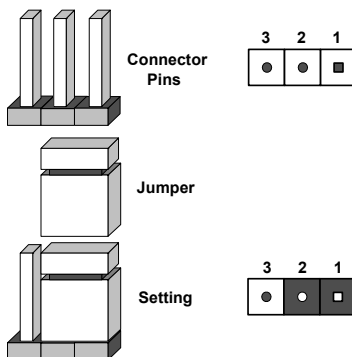

Figure C-2. Rear Jumpers

13. JP80 I<sup>2</sup>C Addr On C0, Off C2 (Not populated)
14. Chip Reset JP36 1-2 Reset, 2-3 No Reset (Not populated)
15. Buzzer Reset\* JP18
16. JP84 1-2 SGPIO, 2-3 I<sup>2</sup>C
17. Chip Reset JP35 1-2 Reset, 2-3 No Reset (Not populated)

### Explanation of Jumpers

To modify the operation of the backplane, jumpers can be used to choose between optional settings. Jumpers create shorts between two pins to change the function of the connector. Pin 1 is identified with a square solder pad on the printed circuit board. Note: On two pin jumpers, "Closed" means the jumper is on and "Open" means the jumper is off the pins.



\*The buzzer sound indicates that a condition requiring immediate attention has occurred.

### ***The buzzer alarm is triggered by the following conditions:***

1. Hard drive failure
2. Fan failure
3. System temperature over 45° Celsius.

## I<sup>2</sup>C and SGPIO Modes and Jumper Settings

This backplane can utilize I<sup>2</sup>C or SGPIO. SGPIO is the default mode and can be used without making changes to your jumper. The following information details which jumper must be configured to use SGPIO mode or restore your backplane to I<sup>2</sup>C mode.

SGPIO Setting (Default)		
Jumper	Jumper Setting	Note
JP84	1-2	SGPIO Mode Setting

I <sup>2</sup> C Setting		
Jumper	Jumper Setting	Note
JP84	2-3	I <sup>2</sup> C Setting

## Rear LED Indicators

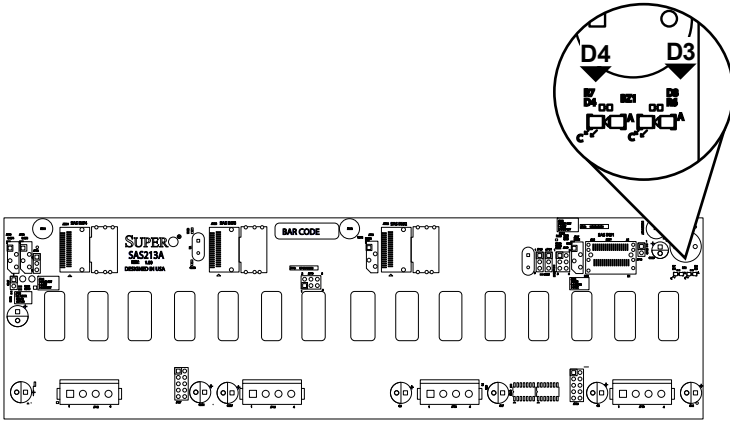

Figure C-3. Rear LEDs

Rear Panel LEDs		
LED	State	Specification
D3	ON	Alarm #1
D4	ON	Alarm #2

## C-7 Front Components, Connectors and LED Indicators

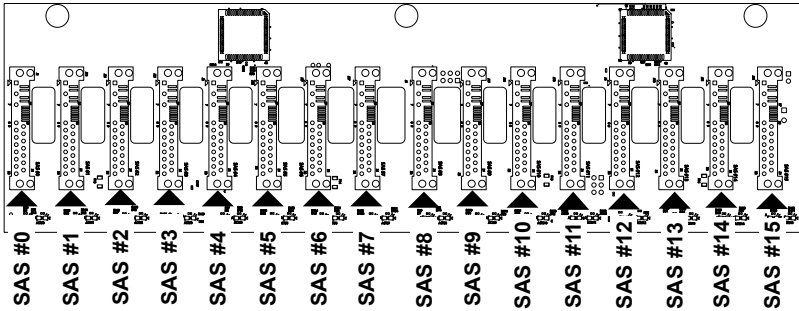

Figure C-4. Front Connectors

SAS/SATA Connectors	
Front Connector	SAS Drive Number
SAS #0	SAS/SATA HDD #0
SAS #1	SAS/SATA HDD #1
SAS #2	SAS/SATA HDD #2
SAS #3	SAS/SATA HDD #3
SAS #4	SAS/SATA HDD #4
SAS #5	SAS/SATA HDD #5
SAS #6	SAS/SATA HDD #6
SAS #7	SAS/SATA HDD #7
SAS #8	SAS/SATA HDD #8
SAS #9	SAS/SATA HDD #9
SAS #10	SAS/SATA HDD #10
SAS #11	SAS/SATA HDD #11
SAS #12	SAS/SATA HDD #12
SAS #13	SAS/SATA HDD #13
SAS #14	SAS/SATA HDD #14
SAS #15	SAS/SATA HDD #15

<b>Front LED Indicators</b>		
<b>LED</b>	<b>Hard Drive Activity</b>	<b>Failure LED</b>
SAS #0	D12	D5
SAS #1	D22	D23
SAS #2	D40	D37
SAS #3	D102	D107
SAS #4	D13	D6
SAS #5	D24	D29
SAS #6	D41	D38
SAS #7	D104	D108
SAS #8	D14	D7
SAS #9	D25	D30
SAS #10	D42	D39
SAS #11	D106	D109
SAS #12	D15	D8
SAS #13	D26	D31
SAS #14	D87	D88
SAS #15	D111	D110

## Appendix D

### BPN-SAS3-213A Backplane Specifications

This manual covers BPN-SAS3-213A connectors, jumpers and indicators.

#### D-1 ESD Safety Guidelines

Electrostatic Discharge (ESD) can damage electronic components. To prevent damage to your system, it is important to handle it very carefully. The following measures are generally sufficient to protect your equipment from ESD.

- Use a grounded wrist strap designed to prevent static discharge.
- Touch a grounded metal object before removing a component from the antistatic bag.
- Handle the backplane by its edges only; do not touch its components, peripheral chips, memory modules or gold contacts.
- When handling chips or modules, avoid touching their pins.
- Put the card and peripherals back into their antistatic bags when not in use.

#### D-2 General Safety Guidelines

- Always disconnect power cables before installing or removing any components from the computer, including the backplane.
- Disconnect the power cable before installing or removing any cables from the backplane.
- Make sure that the backplane is securely and properly installed on the motherboard to prevent damage to the system due to power shortage.

## **D-3 Version Information**

The BPN-SAS3-213A backplane has been designed to utilize the most up-to-date technology available, providing your system with reliable, high-quality performance.

This manual reflects BPN-SAS3-213A Revision 1.00, the most current release available at the time of publication. Always refer to the Supermicro Web site at [www.supermicro.com](http://www.supermicro.com) for the latest updates, compatible parts and supported configurations.



## D-4 Rear Connectors

The following connectors are on the side of the backplane that faces the rear of the chassis. They are marked by silkscreen labels.

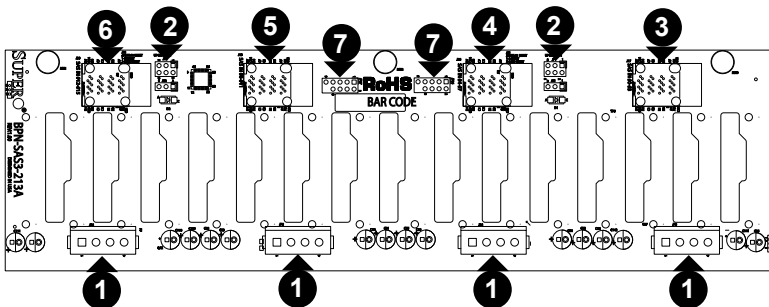

Figure D-1. Rear Connectors

### Front Connectors

1. Power Connectors (4-pin): JP3, JP4, JP5, and JP6
2. Upgrade Connectors: JP1 and JP2
3. SAS IN #0-#3: J17
4. SAS IN #4-#7: J18
5. SAS IN #8-#11: J19
6. SAS IN #12-#15: J20
7. For manufacturer's use only: JP26 and JP27

## D-5 Rear Connector and Pin Definitions

### 1. Backplane Main Power Connectors

The 4-pin connectors, designated JP3, JP4, JP5 and JP6 provide power to the backplane. See the table on the right for pin definitions.

Backplane Main Power 4-Pin Connector	
Pin#	Definition
1	+12V
2 and 3	Ground
4	+5V

### 2. Upgrade Connectors

The upgrade connectors, JP1 and JP2, are used for manufacturer purposes only.

### 3-6. SAS IN Ports (Sideband included)

The SAS ports are used to connect the SAS drive cables. The four SAS IN ports are designated J17, J18, J19 and J20. Each port is also compatible with SATA drives.

Sideband Definitions (J17-J20)			
Pin #	Definition	Pin #	Definition
A0	SB0	C1	SB4
B2	SB1	D1	SB5
C2	SB2	D2	SB6
B1	SB3	A1	SB7

## D-6 Rear Jumper Locations and Pin Definitions

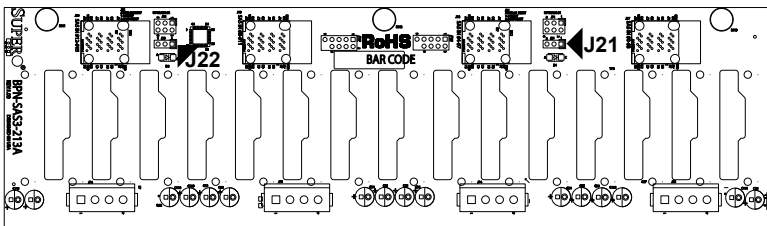
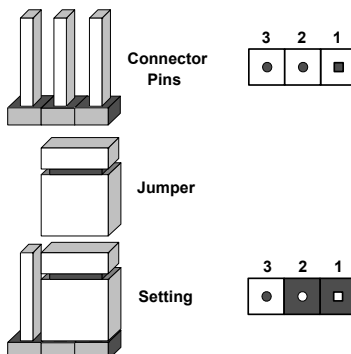

Figure D-2. Rear Jumpers

Jumper Settings	
Jumper	Description
J21	Chip reset, for manufacturing use only. Pins 1-2: Reset, red LED is always on Pins 2-3: No reset, LED operates normally (default)
J22	Chip reset, for manufacturing use only. Pins 1-2: Reset, red LED is always on Pins 2-3: No reset, LED operates normally (default)

### Explanation of Jumpers

To modify the operation of the backplane, jumpers can be used to choose between optional settings. Jumpers create shorts between two pins to change the function of the connector. Pin 1 is identified with a square solder pad on the printed circuit board. Note: On two pin jumpers, "Closed" means the jumper is on and "Open" means the jumper is off the pins.



## D-7 Front Connectors and LED Indicators

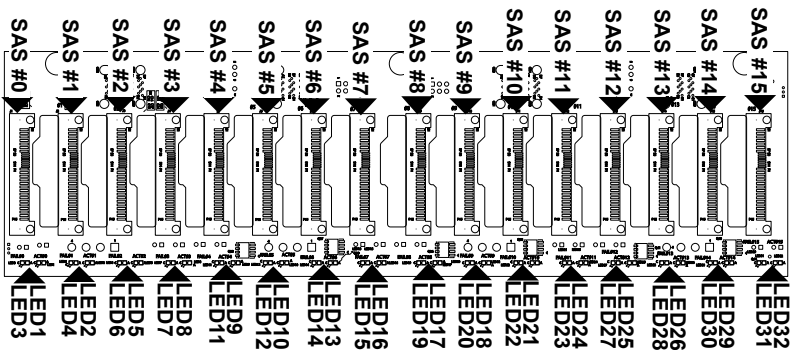

Figure D-3. SAS/SATA Connectors and LED Indicators

Connector	SAS Drive Number	Failure LED	Activity LED
SAS #0	SAS/SATA HDD #0	LED3	LED1
SAS #1	SAS/SATA HDD #1	LED4	LED2
SAS #2	SAS/SATA HDD #2	LED6	LED5
SAS #3	SAS/SATA HDD #3	LED7	LED8
SAS #4	SAS/SATA HDD #4	LED11	LED9
SAS #5	SAS/SATA HDD #5	LED12	LED10
SAS #6	SAS/SATA HDD #6	LED14	LED13
SAS #7	SAS/SATA HDD #7	LED15	LED16
SAS #8	SAS/SATA HDD #8	LED19	LED17
SAS #9	SAS/SATA HDD #9	LED20	LED18
SAS #10	SAS/SATA HDD #10	LED22	LED21
SAS #11	SAS/SATA HDD #11	LED23	LED24
SAS #12	SAS/SATA HDD #12	LED27	LED25
SAS #13	SAS/SATA HDD #13	LED28	LED26
SAS #14	SAS/SATA HDD #14	LED30	LED29
SAS #15	SAS/SATA HDD #15	LED31	LED32

## Notes

Disclaimer (cont.)

The products sold by Supermicro are not intended for and will not be used in life support systems, medical equipment, nuclear facilities or systems, aircraft, aircraft devices, aircraft/emergency communication devices or other critical systems whose failure to perform be reasonably expected to result in significant injury or loss of life or catastrophic property damage. Accordingly, Supermicro disclaims any and all liability, and should buyer use or sell such products for use in such ultra-hazardous applications, it does so entirely at its own risk. Furthermore, buyer agrees to fully indemnify, defend and hold Supermicro harmless for and against any and all claims, demands, actions, litigation, and proceedings of any kind arising out of or related to such ultra-hazardous use or sale.

## Appendix E

### BPN-SAS3-213A-N8 Backplane Specifications

#### E-1 ESD Safety Guidelines

Electrostatic Discharge (ESD) can damage electronic components. To prevent damage to your system, it is important to handle it very carefully. The following measures are generally sufficient to protect your equipment from ESD.

- Use a grounded wrist strap designed to prevent static discharge.
- Touch a grounded metal object before removing a component from the antistatic bag.
- Handle the backplane by its edges only; do not touch its components, peripheral chips, memory modules or gold contacts.
- When handling chips or modules, avoid touching their pins.
- Put the card and peripherals back into their antistatic bags when not in use.

#### E-2 General Safety Guidelines

- Always disconnect power cables before installing or removing any components from the computer, including the backplane.
- Disconnect the power cable before installing or removing any cables from the backplane.
- Make sure that the backplane is securely and properly installed on the motherboard to prevent damage to the system due to power shortage.

#### E-3 A Note to Users

All images and layouts in this user's guide are based upon the latest PCB revision available at the time of publishing. The card you have received may not look exactly the same as the graphics in this manual.

## **E-4 Introduction to the BPN-SAS3-213A-N8 Backplane**

The BPN-SAS3-213A-N8 backplane has been designed to utilize the most up-to-date technology available, providing your system with reliable, high-quality performance.

Always refer to the Supermicro web site at [www.supermicro.com](http://www.supermicro.com) for the latest updates, compatible parts, and supported configurations.



## E-5 Front Connectors

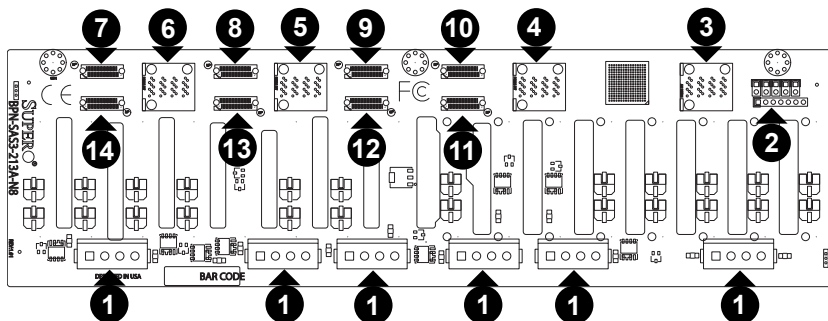

Figure 2-1. Front Connectors

### Front Connectors

- |  |                      |
|--|----------------------|
| 1. Power Connectors (4-pin): JPW3, JPW2, JPW1, JPW6, JPW5, and JPW4. | 7. NVMe IN #15: CN8  |
| 2. Upgrade Connector: JP1  | 8. NVMe IN #13: CN4  |
| 3. SAS IN #0-#3: JSM1  | 9. NVMe IN #11: CN7  |
| 4. SAS IN #4-#7: JSM3  | 10. NVMe IN #9: CN3  |
| 5. SAS IN #8-#11: JSM2   | 11. NVMe IN #8: CN1  |
| 6. SAS IN #12-#15: JSM4  | 12. NVMe IN #10: CN5 |
|  | 13. NVMe IN #12: CN2 |
|  | 14. NVMe IN #14: CN6 |

## E-6 Front Connector and Pin Definitions

### 1. Backplane Main Power Connectors

The 4-pin connectors, designated JPW3, JPW2, JPW1, JPW6, JPW5, and JPW4, provide power to the backplane. See the table on the right for pin definitions.

Backplane Main Power 4-Pin Connector	
Pin#	Definition
1	+12V
2 and 3	Ground
4	+5V

### 2. Upgrade Connector

The upgrade connector is used for manufacturer diagnostic purposes only.

### 3. - 6. SAS IN Ports (Sideband included)

The SAS ports are used to connect the SAS3 drive cables. The four SAS IN ports are designated JSM1, JSM3, JSM2, and JSM4. Each port is also compatible with SATA drives. However, mixing SAS3 and SATA drives is not recommended.

Sideband Definitions (JSM1 - JSM4)			
Pin #	Definition	Pin #	Definition
A0	SB0	C1	SB4
B2	SB1	D1	SB5
C2	SB2	D2	SB6
B1	SB3	A1	SB7

### 7. - 10. NVMe IN Ports

The NVMe ports are used to connect the NVMe drive cables. OcuLink cable CBL-SAST-0820 should be used to connect these ports to the corresponding ports on add-on card AOC-SLG3-4E2P. The add-on card in slot 1 of the motherboard should have its ports CN1, CN2, CN3, and CN4 connected to the backplane's ports CN1, CN3, CN5, and CN7, respectively. The add-on card in slot 2 of the motherboard should have its ports CN1, CN2, CN3, and CN4 connected to CN2, CN4, CN6, and CN8, respectively.

## E-7 Front Jumpers

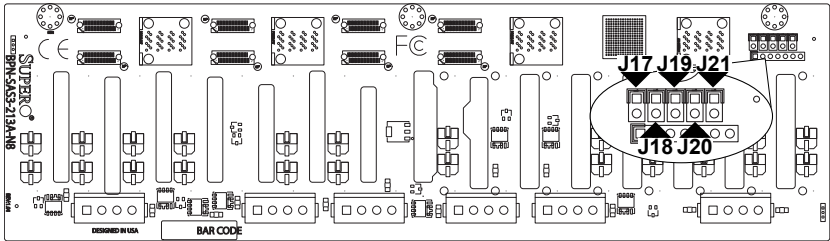
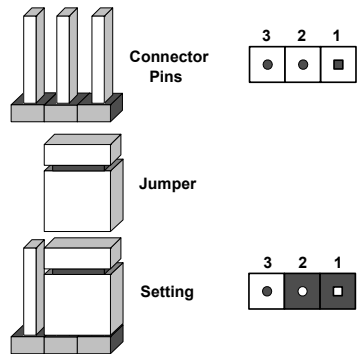

Figure 2-2. Front Jumpers

### Explanation of Jumpers

To modify the operation of the backplane, jumpers can be used to choose between optional settings. Jumpers create shorts between two pins to change the function of the connector. Pin 1 is identified with a square solder pad on the printed circuit board. Note: On two pin jumpers, "Closed" means the jumper is on and "Open" means the jumper is off the pins.



<b>Jumper Settings</b>					
<b>Jumper</b>					<b>Description</b>
J17 CPU_SEL0	J18 CPU_SEL1	J19 CPU_SEL2	J20 I2C_SEL0	J21 I2C_SEL1	
0	0				NVMe drive connection 8+0
0	1				NVMe drive connection 4+4 (default for two 4-NVMe AOC interface)
1	0				NVMe drive connection 2+6
1	1				NVMe drive connection 6+2
		0			Reserved for future use. Open by default.
			0	0	BMC I2C address is 66h (default)
			0	1	BMC I2C address is 76h
			1	0	BMC I2C address is 6Eh
			1	1	BMC I2C address is 7Eh

## E-8 Rear Components, Connectors, and LED Indicators

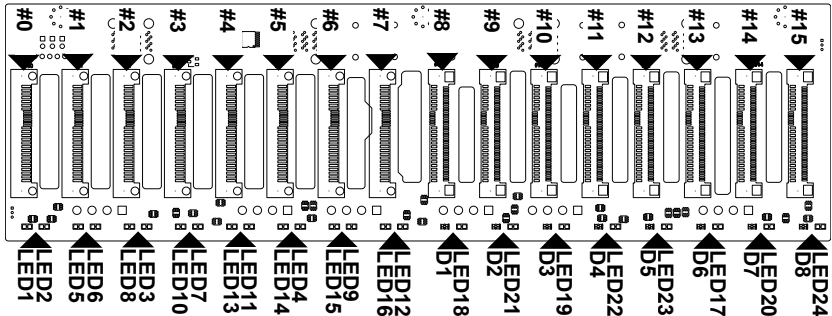

Figure 2-3. Rear SAS/SATA Connectors and LED Indicators

SAS/SATA/NVMe Connectors and LED Indicators			
Rear Connector	SAS Drive Number	Failure LED	Activity LED
#0	SAS3/SATA HDD #0	LED1	LED2
#1	SAS3/SATA HDD #1	LED5	LED6
#2	SAS3/SATA HDD #2	LED8	LED3
#3	SAS3/SATA HDD #3	LED10	LED7
#4	SAS3/SATA HDD #4	LED13	LED11
#5	SAS3/SATA HDD #5	LED14	LED4
#6	SAS3/SATA HDD #6	LED15	LED9
#7	SAS3/SATA HDD #7	LED16	LED12
#8	SAS3/SATA/NVMe HDD #8	D1	LED18
#9	SAS3/SATA/NVMe HDD #9	D2	LED21
#10	SAS3/SATA/NVMe HDD #10	D3	LED19
#11	SAS3/SATA/NVMe HDD #11	D4	LED22
#12	SAS3/SATA/NVMe HDD #12	D5	LED23
#13	SAS3/SATA/NVMe HDD #13	D6	LED17
#14	SAS3/SATA/NVMe HDD #14	D7	LED20
#15	SAS3/SATA/NVMe HDD #15	D8	LED24

Disclaimer (cont.)

The products sold by Supermicro are not intended for and will not be used in life support systems, medical equipment, nuclear facilities or systems, aircraft, aircraft devices, aircraft/emergency communication devices, or other critical systems whose failure to perform be reasonably expected to result in significant injury or loss of life or catastrophic property damage. Accordingly, Supermicro disclaims any and all liability, and should buyer use or sell such products for use in such ultra-hazardous applications, it does so entirely at its own risk. Furthermore, buyer agrees to fully indemnify, defend and hold Supermicro harmless for and against any and all claims, demands, actions, litigation, and proceedings of any kind arising out of or related to such ultra-hazardous use or sale.