

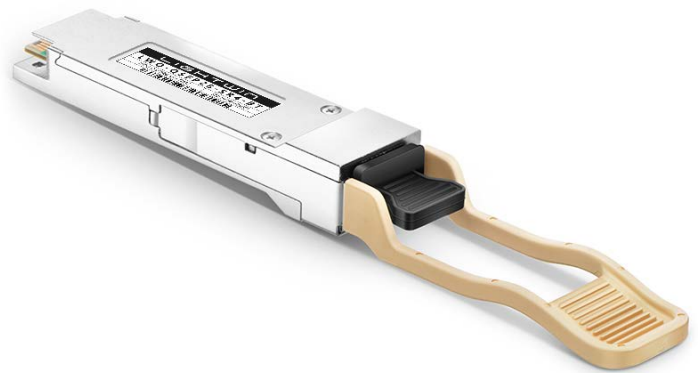

# 100Gb/s QSFP28 SR4 850nm 100m Optical Transceiver

## LWO-QSFP28-SR4-BT

### Product Specification



### Features

- MPO/MTP optical interface (Max:2.5W)
- Up to 100m OM4 MMF Distance
- Single +3.3V power supply
- Hot-pluggable QSFP28 MSA form factor
- 4x25G Electrical Serial Interface
- Transmitter: 4x25Gb/s 850nm VCSEL
- Receiver: 4x25Gb/s PIN
- Low power dissipation
- Built in digital diagnostic function
- Operating case temperature range: 0°C to 70°C
- Compliant with 100GBASE-SR4
- I2C Communication Interface

### Applications

- 100GBASE-SR4
- InfiniBand QDR and DDR interconnects
- 100G Datacom connections

## ■ Functional Description

The QSFP28 100G SR4 optical transmitter portion of the transceiver incorporates a 4-channel 850nm VCSEL (Vertical Cavity Surface Emitting Laser) array, a 4-channel input buffer and laser driver, diagnostic monitors, control and bias blocks. For module control, the control interface incorporates a 2-wire serial interface of clock and data signals. Diagnostic monitors for VCSEL bias, module temperature, transmitted optical power, received optical power and supply voltage are implemented and results are available through the 2-wire serial interface. Alarm and warning thresholds are established for the monitored attributes. Flags are set and interrupts generated when the attributes are outside the thresholds. Flags are also set and interrupts generated for loss of input signal (LOS) and transmitter fault conditions. All flags are latched and will remain set even if the condition initiating the latch clears and operation resumes. All interrupts can be masked and flags are reset by reading the appropriate flag register. The optical output will squelch for loss of input signal unless squelch is disabled. Fault detection or channel deactivation through the 2-wire serial interface will disable the channel. Status, alarm/warning and fault information are available via the 2-wire serial interface.

## ■ Transceiver Block Diagram

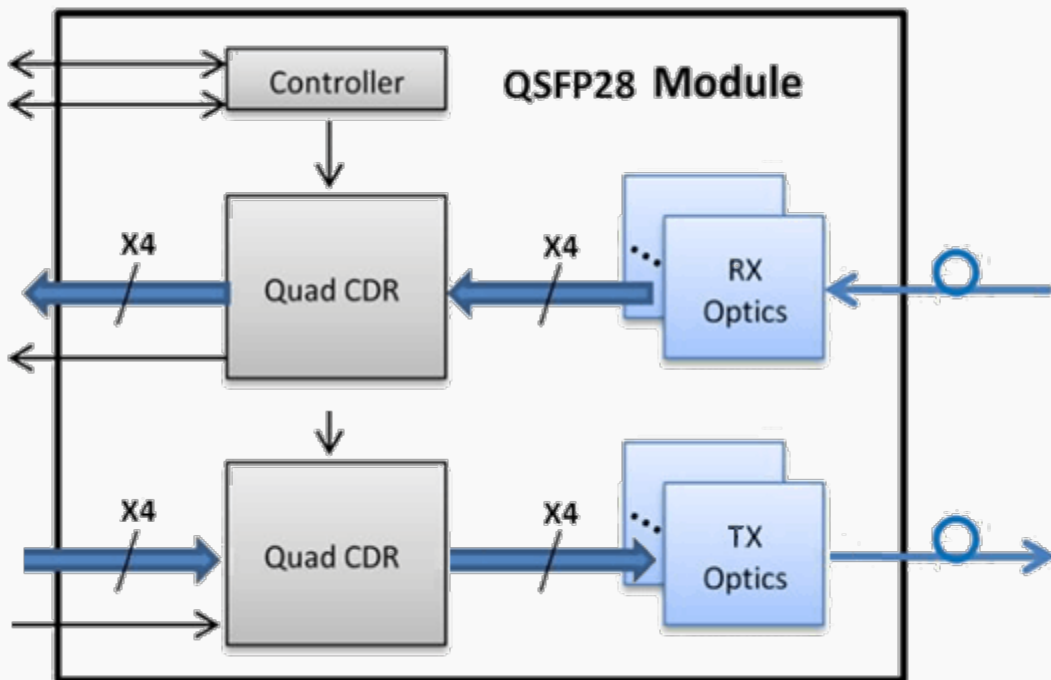

Figure 1. Transceiver Block Diagram

## Pin Assignment and Description

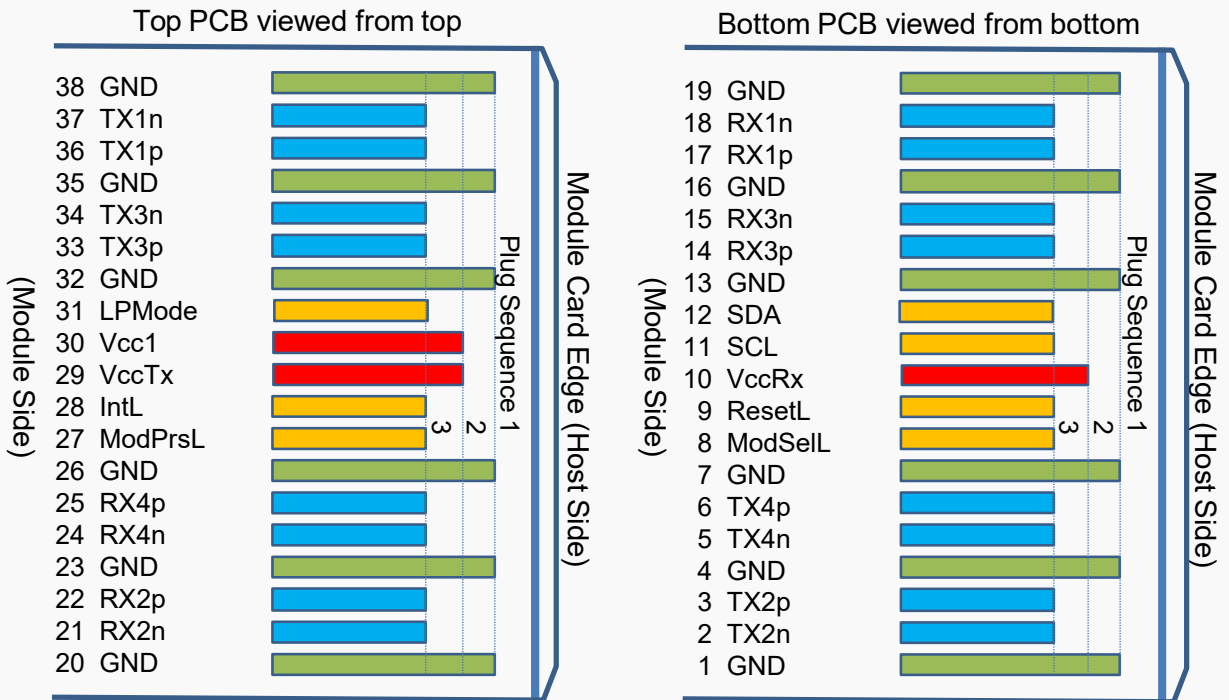

Figure 2. MSA Compliant Connector

### Pin Definition

PIN	Logic	Symbol	Name/Description	Notes
1		GND	Ground	1
2	CML-I	Tx2n	Transmitter Inverted Data Input	
3	CML-I	Tx2p	Transmitter Non-Inverted Data output	
4		GND	Ground	1
5	CML-I	Tx4n	Transmitter Inverted Data Input	
6	CML-I	Tx4p	Transmitter Non-Inverted Data output	
7		GND	Ground	1
8	LVTLL-I	ModSelL	Module Select	
9	LVTLL-I	ResetL	Module Reset	
10		VccRx	+3.3V Power Supply Receiver	2
11	LVC MOS-I/O	SCL	2-Wire Serial Interface Clock	
12	LVC MOS-I/O	SDA	2-Wire Serial Interface Data	
13		GND	Ground	
14	CML-O	Rx3p	Receiver Non-Inverted Data Output	
15	CML-O	Rx3n	Receiver Inverted Data Output	
16		GND	Ground	1
17	CML-O	Rx1p	Receiver Non-Inverted Data Output	
18	CML-O	Rx1n	Receiver Inverted Data Output	
19		GND	Ground	1

PIN	Logic	Symbol	Name/Description	Notes
20		GND	Ground	1
21	CML-O	Rx2n	Receiver Inverted Data Output	
22	CML-O	Rx2p	Receiver Non-Inverted Data Output	
23		GND	Ground	1
24	CML-O	Rx4n	Receiver Inverted Data Output	1
25	CML-O	Rx4p	Receiver Non-Inverted Data Output	
26		GND	Ground	1
27	LVTTL-O	ModPrsL	Module Present	
28	LVTTL-O	IntL	Interrupt	
29		VccTx	+3.3 V Power Supply transmitter	2
30		Vcc1	+3.3 V Power Supply	2
31	LVTTL-I	LPMode	Low Power Mode	
32		GND	Ground	1
33	CML-I	Tx3p	Transmitter Non-Inverted Data Input	
34	CML-I	Tx3n	Transmitter Inverted Data Output	
35		GND	Ground	1
36	CML-I	Tx1p	Transmitter Non-Inverted Data Input	
37	CML-I	Tx1n	Transmitter Inverted Data Output	
38		GND	Ground	1

Notes:

1. GND is the symbol for signal and supply (power) common for the QSFP28 module. All are common within the module and all module voltages are referenced to this potential unless otherwise noted. Connect these directly to the host board signal common ground plane.
2. VccRx, Vcc1 and VccTx are the receiving and transmission power suppliers and shall be applied concurrently. Recommended host board power supply filtering is shown in Figure 3 below. Vcc Rx, Vcc1 and Vcc Tx may be internally connected within the module in any combination. The connector pins are each rated for a maximum current of 1000mA.

### ■ Optical Interface Lanes and Assignment

Figure 3 shows the orientation of the multi-mode fiber facets of the optical connector. Table 1 provides the lane assignment.

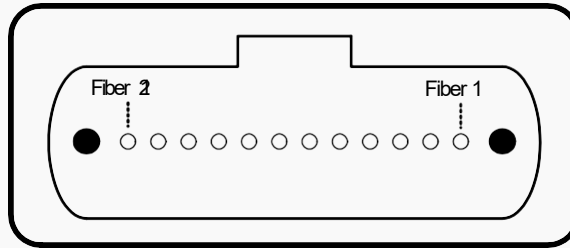

Figure 3. Outside View of the QSFP28 Module MPO Receptacle

**Table 1: Lane Assignment**

Fiber #	Lane Assignment	Fiber #	Lane Assignment	Fiber #	Lane Assignment
1	RX0	5,6,7,8	Not used	9	TX3
2	RX1			10	TX2
3	RX2			11	TX1
4	RX3			12	TX0

### ■ Recommended Power Supply Filter

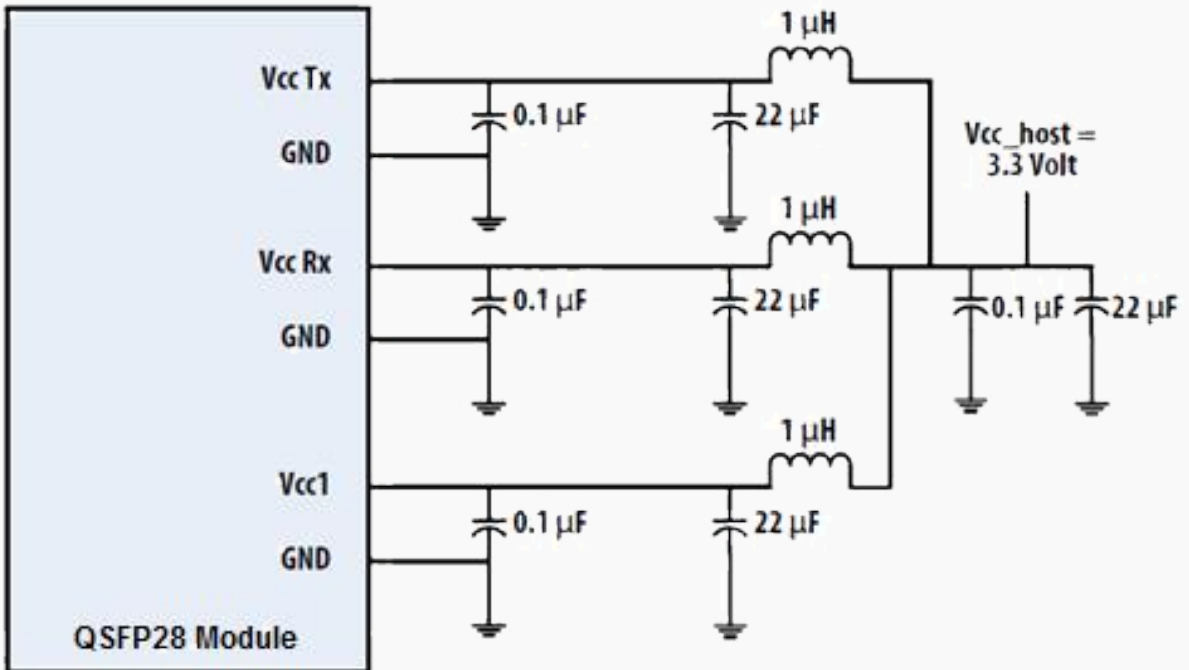

Figure 4. Recommended Power Supply Filter

## ■ Optical Characteristics (Top=0~70°C, Vcc=3.14~3.47V)

Parameter	Symbol	Min	Typ	Max	Unit	Notes
Transmitter						
Transmit Rate for Each Lane	DR <sub>PL</sub>		25.78		Gb/s	1
Center Wavelength	$\lambda$	840	850	860	nm	
RMS Spectral Width	RSW			0.6	nm	
Average launch power, each lane	P <sub>avg</sub>	-8.4	-	2.4	dBm	
Optical modulation amplitude, each lane (OMA)	OMA	-6.4	-	3	dBm	
Extinction Ratio	ER	2	-	-	dB	
Average Launch Power of OFF Transmitter, per Lane	R <sub>in</sub>	-	-	-30	dBm	
Optical return loss tolerance		-	-	12	dB	
Transmitter eye mask {X1,X2,X3,Y1,Y2,Y3}		{0.3,0.38,0.45,0.35,0.41,0.5}				2
Receiver						
Receive Rate for Each Lane	DR <sub>PL</sub>		25.78		Gb/s	3
Four Lane Wavelength Range	$\lambda$	840	850	860	nm	
Overload Input Optical Power	P <sub>max</sub>	3.4	-	-	dBm	
Average Receive Power for Each	P <sub>in</sub>	-10.3		2.4	dBm	4
Receiver sensitivity , each lane	P <sub>sens</sub>		-	-7	dBm	5
Receive Reflectance	REFL <sub>r</sub>	-	-	-12	dB	
Los De-Assert	P <sub>d</sub>	-	-	-13	dBm	
Los Assert	P <sub>a</sub>	-30	-	-	dBm	
Loss Hysteresis	P <sub>d</sub> -P <sub>a</sub>	0.5			dBm	

### Note:

1. Transmitter consists of 4 lasers operating at a maximum speed of 25.78125Gb/s  $\pm$ 100ppm each.
2. Hit Ratio  $1.5 \times 10^{-3}$  hits/sample.
3. Receiver consists of 4 photodetectors operating at a maximum speed of 25.78125Gb/s  $\pm$ 100ppm each.
4. Minimum value is informative only and not the principal indicator of signal strength.
5. BER  $1 \times 10^{-12}$

## ■ Absolute Maximum Ratings

It has to be noted that the operation in excess of any individual absolute maximum ratings might cause permanent damage to this module.

Parameter	Symbol	Min	Max	Units	Note
Storage Temperature	T <sub>S</sub>	-40	85	degC	
Operating Case Temperature	T <sub>OP</sub>	0	70	degC	
Power Supply Voltage	V <sub>CC</sub>	-0.5	3.6	V	
Relative Humidity (non- condensation)	RH	0	85	%	
Damage Threshold, each Lane	TH <sub>d</sub>	3.4		dBm	

## ■ Recommended Operating Conditions and Power Supply Requirements

Parameter	Symbol	Min	Typical	Max	Units
Operating Case Temperature	T <sub>OP</sub>	0		70	degC
Power Supply Voltage	V <sub>CC</sub>	3.135	3.3	3.465	V
Data Rate, each Lane			25.78125		Gb/s
Power Consumption				2.5	W
Link Distance (OM3 MMF)	D1			70	m
Link Distance (OM4 MMF)	D2			100	m

## ■ Digital Diagnostic Functions

The following digital diagnostic characteristics are defined over the Recommended Operating Environment unless otherwise specified. It is compliant to SFF-8436.

Parameter	Symbol	Min	Max	Units	Notes
Temperature monitor absolute error	DMI_Temp	-3	3	degC	Over operating temperature range
Supply voltage monitor absolute error	DMI_VCC	-0.15	0.15	V	Over full operating range
Channel RX power monitor absolute error	DMI_RX_Ch	-2	2	dB	1
Channel Bias current monitor	DMI_Ibias_Ch	-10%	10%	mA	Ch1~Ch4
Channel TX power monitor absolute error	DMI_TX_Ch	-2	2	dB	1

Notes:

1. Due to measurement accuracy of different single mode fibers, there could be an additional +/- 1 dB fluctuation, or a +/- 3 dB total accuracy.

## ■ Mechanical Dimensions

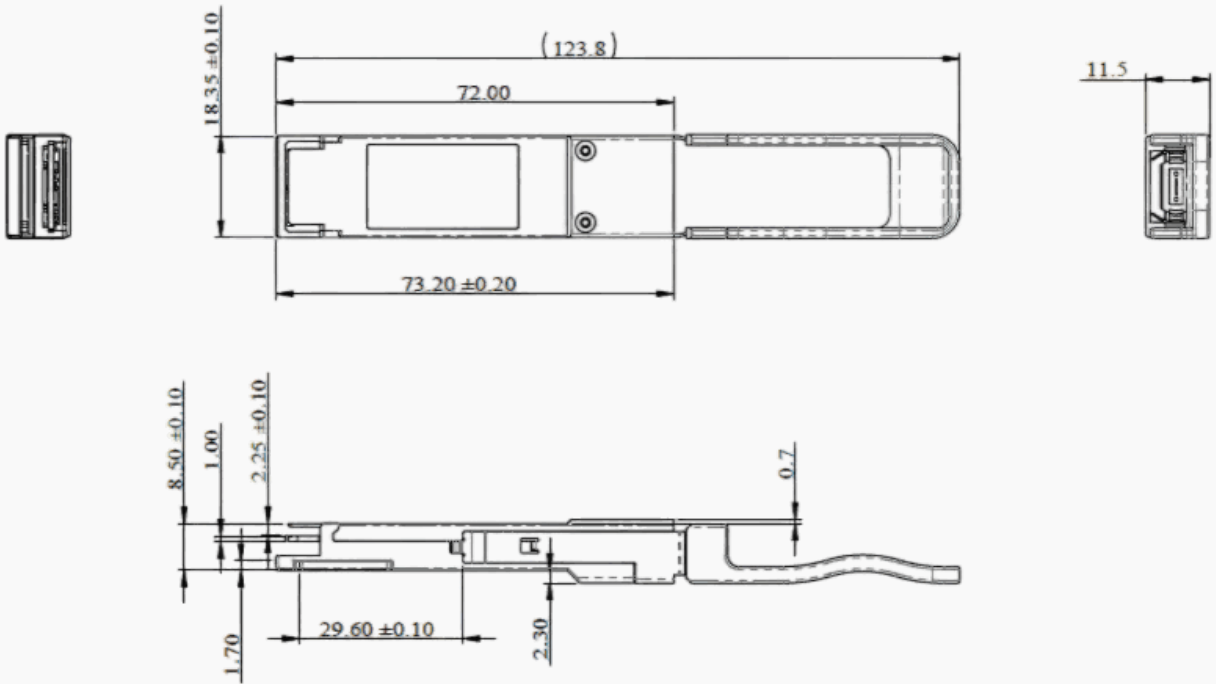

Figure 5. Mechanical Outline

## ■ ESD

This transceiver is specified as ESD threshold 1kV for high speed data pins and 2kV for all other electrical input pins, tested per MIL-STD-883, Method 3015.4 /JESD22- A114-A (HBM). However, normal ESD precautions are still required during the handling of this module. This transceiver is shipped in ESD protective packaging. It should be removed from the packaging and handled only in an ESD protected environment.

## ■ Laser Safety

This is a Class 1 Laser Product according to EN 60825-1:2014. This product complies with 21 CFR 1040.10 and 1040.11 except for deviations pursuant to Laser Notice No. 50, dated (June 24, 2007).

Caution: Use of controls or adjustments or performance of procedures other than those specified herein may result in hazardous radiation exposure.

## Part Number Ordering Information

LWO-QSFP28-SR4-BT	QSFP28 SR4 850nm 100m optical transceiver with full real-time digital diagnostic monitoring and pull tab
-------------------	--