

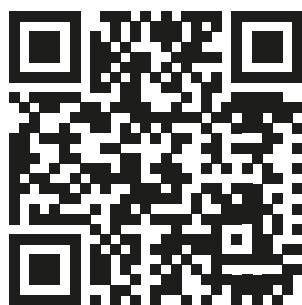

*Supreme Style*  
by Trisa Electronics

Dieses Booklet ist in weiteren Sprachen digital erhältlich:  
Ce livret est disponible en version numérique dans d'autres langues :  
Questo opuscolo è disponibile in formato digitale in altre lingue:  
This booklet is available digitally in additional languages:  
Este folleto está disponible en formato digital en otros idiomas:



[www.trisaelectronics.ch/supremestyle](http://www.trisaelectronics.ch/supremestyle)

## *Dear Customer*

With your purchase of the “Supreme Style” Multistyler, you’re not just holding a multifunctional tool; you’re embracing an experience. Every strand, every curl, every look you can imagine is now within your reach. This isn’t just a device – it’s your ticket to a realm of boundless creativity and self-expression.

Imagine waking up each morning with the freedom to choose a new style that perfectly aligns with your mood. A style that reflects your personality, your uniqueness, and your vision. With the “Supreme Style” this is now a reality.

In this Style Guide, you’ll find more than just instructions for using the accessories. We’ve included inspirations, tips, and secrets to help you make the most of every styling opportunity.

Join us on a journey where you’re the star, and the “Supreme Style” is your faithful companion.

Ready to conquer the world with your style? Let’s get started!

*Your team of Trisa Electronics*



<b>The Supreme Style Overview</b>	.....	<b>6</b>
<b>The incredible Curls Hair curler</b>	.....	<b>8</b>
	Step by step	<b>10</b>
<b>Luxurious Waves</b>	Oval and round brush	<b>12</b>
	Step by step	<b>13</b>
<b>The Sleek-Look</b>	Drying accessory and nozzle	<b>16</b>
	Step by step	<b>17</b>
<b>Voluminous Mane</b>	Diffuser	<b>18</b>
	Step by step	<b>19</b>
<b>Styling Secrets</b>	.....	<b>20</b>
<b>Hair Care Supreme</b>	.....	<b>22</b>
<b>Contact</b>	.....	<b>23</b>

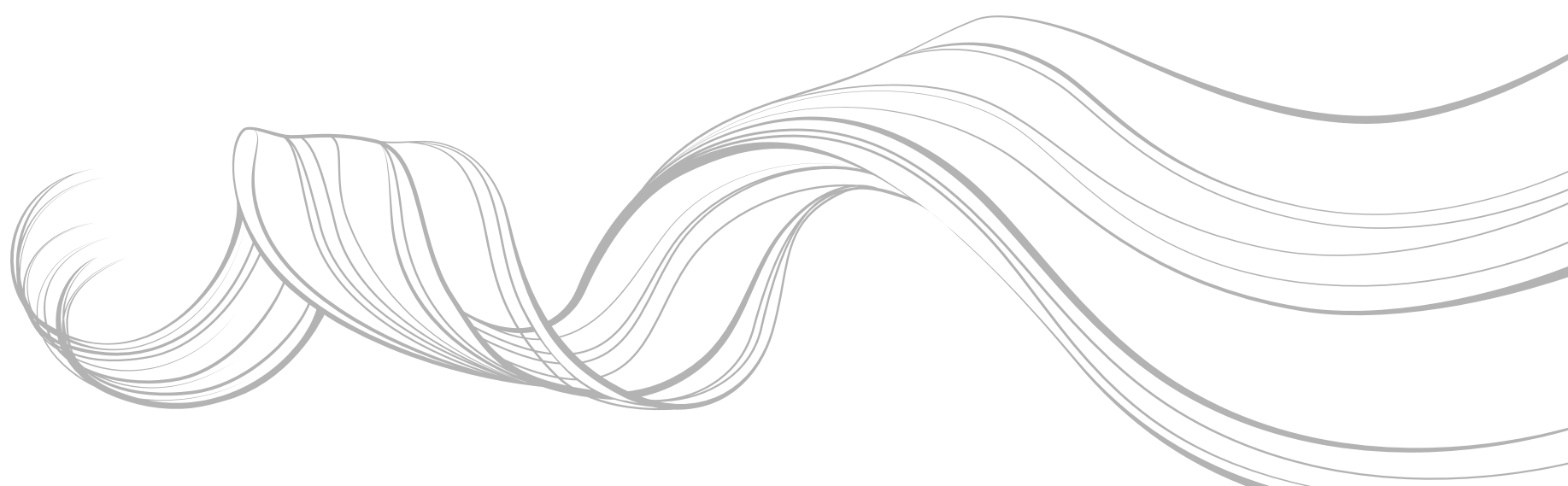

# The Supreme Style

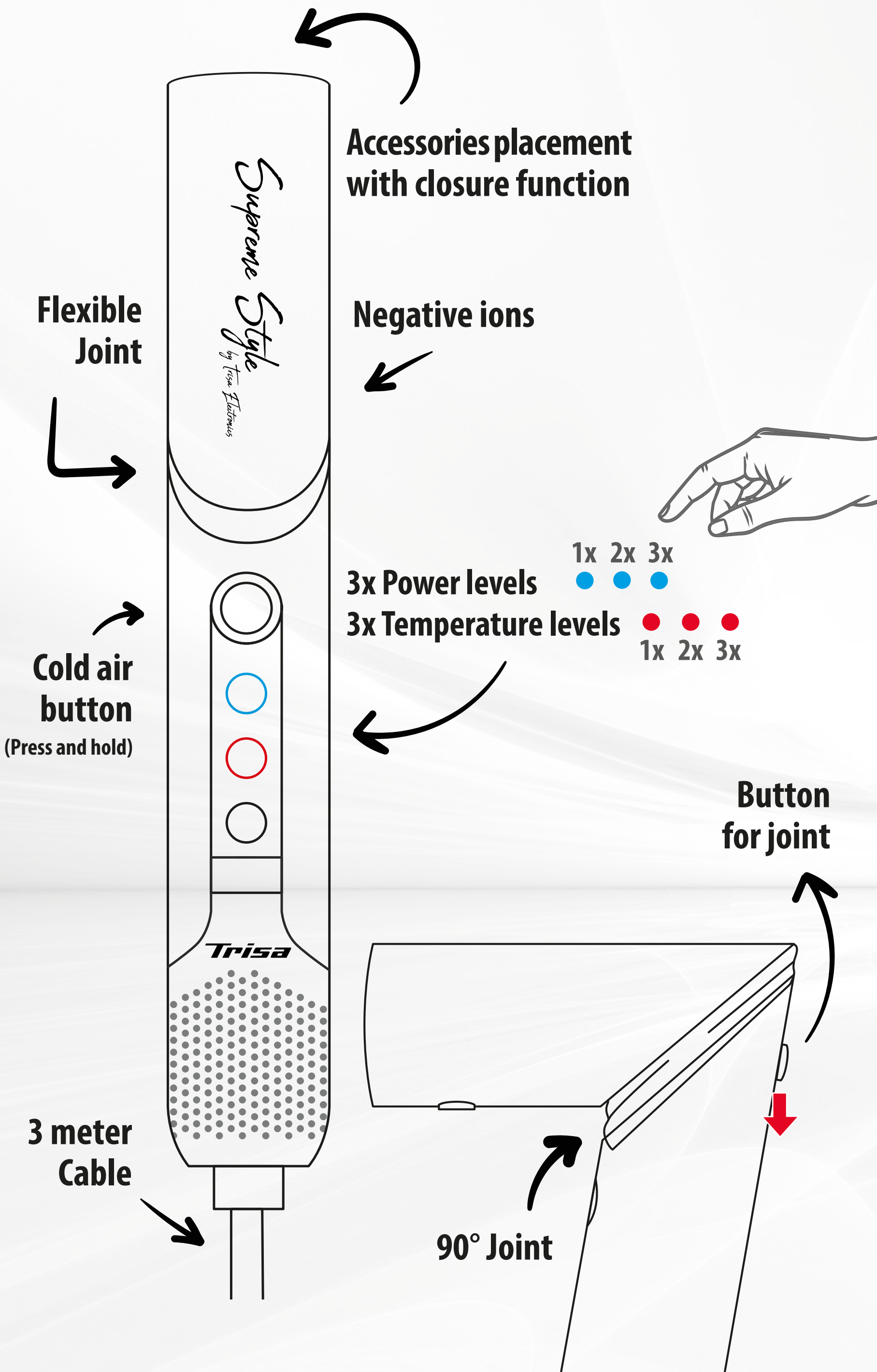

# Accessories

## 30 mm Hair curler

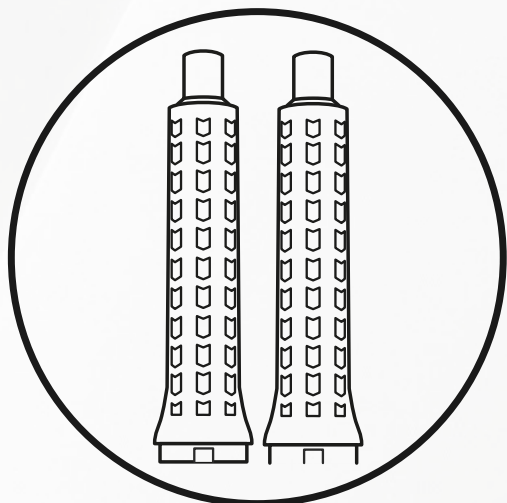

## 38 mm Hair curler

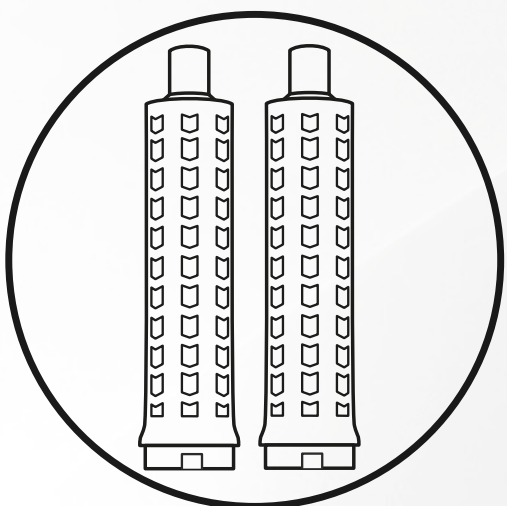

## Drying accessory

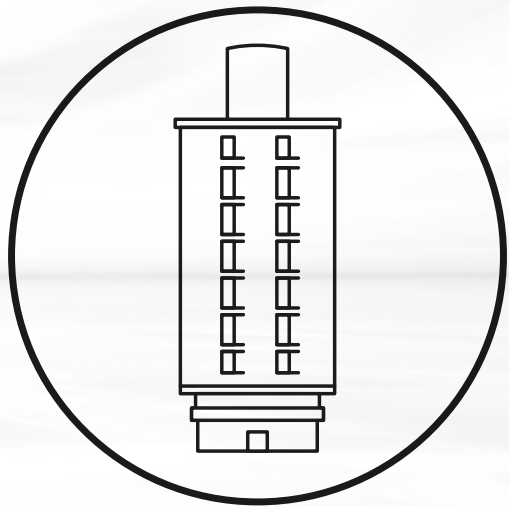

## Diffuser

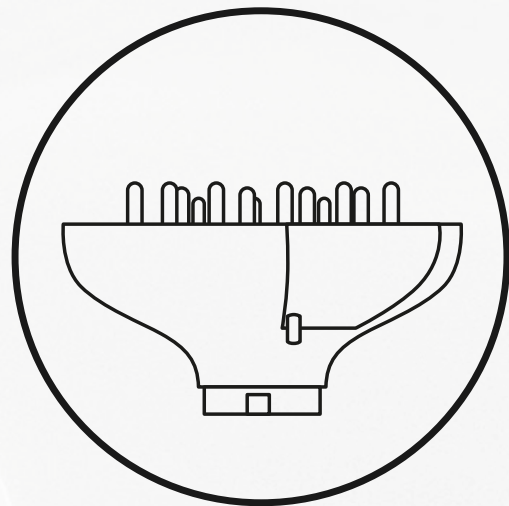

## Round brush

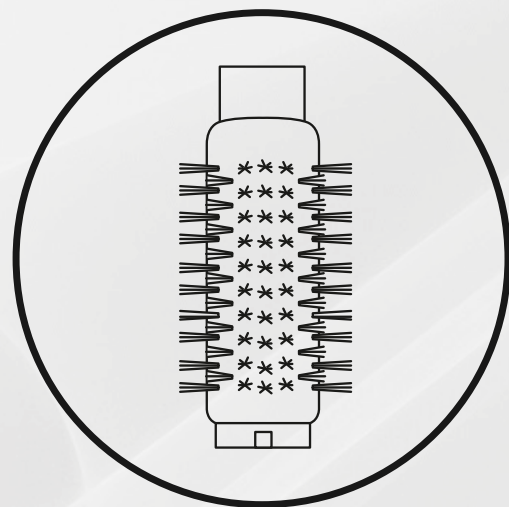

## Oval brush

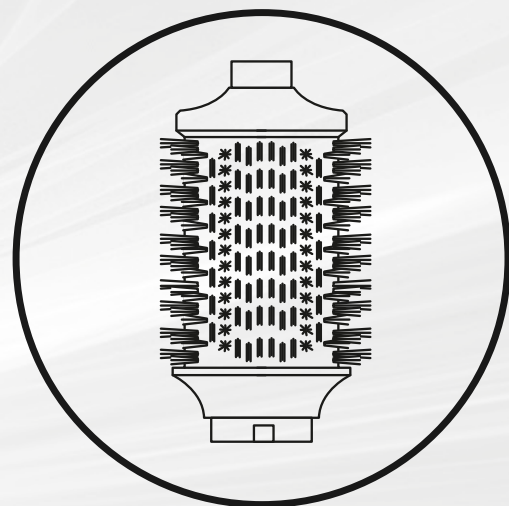

## Styling nozzle

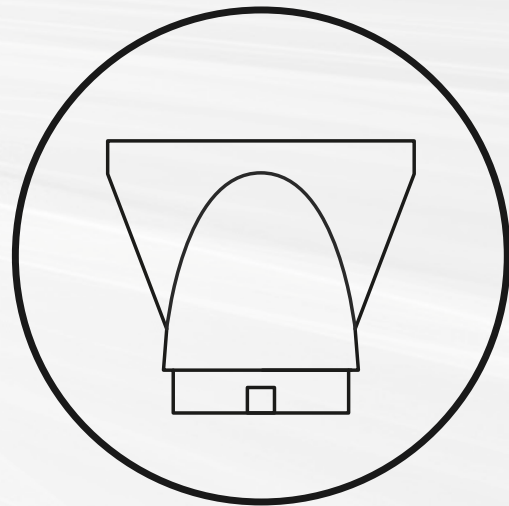



# The incredible Curls

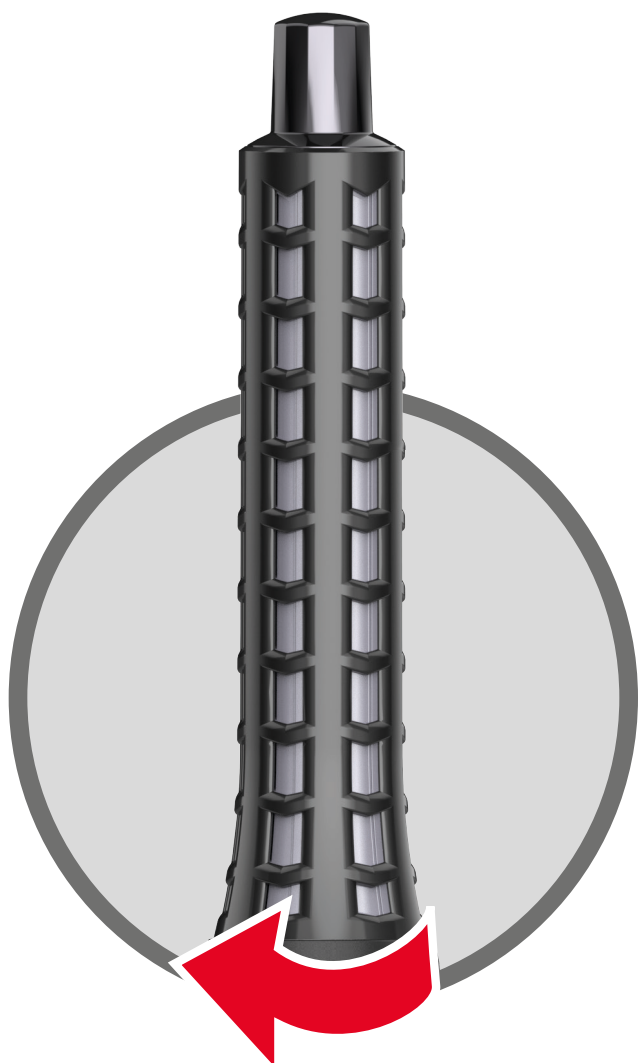

**30 mm Hair curler  
for smaller curls  
clockwise**



Recommended setting

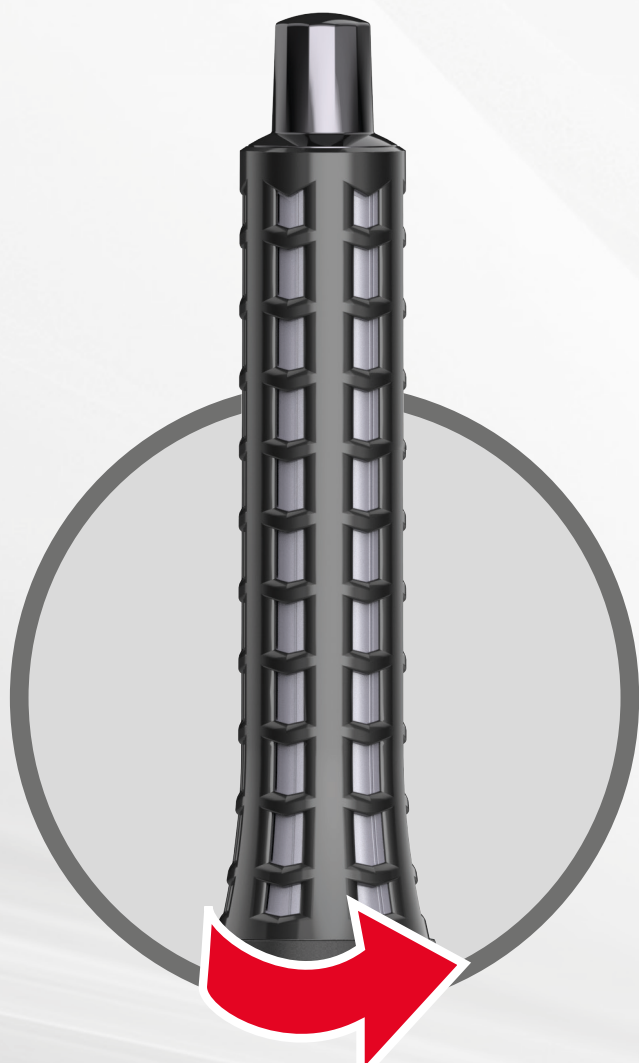
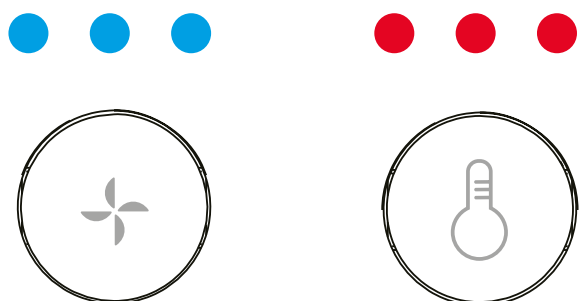

**30 mm Hair curler  
for smaller curls  
counterclockwise**

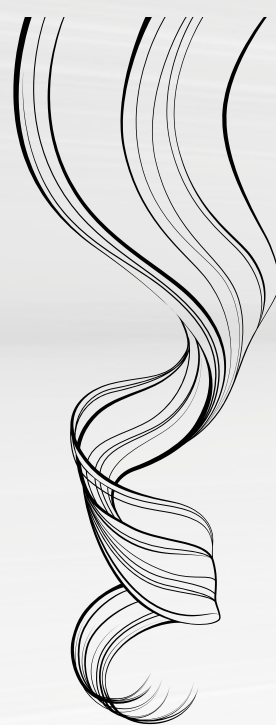

Recommended setting

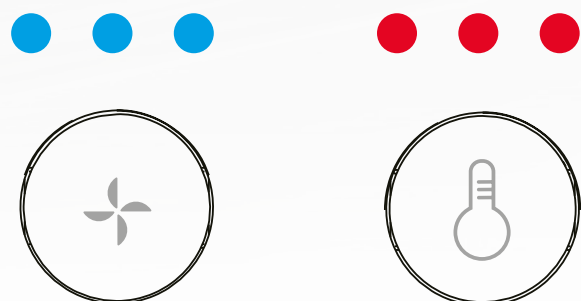



# The incredible Curls

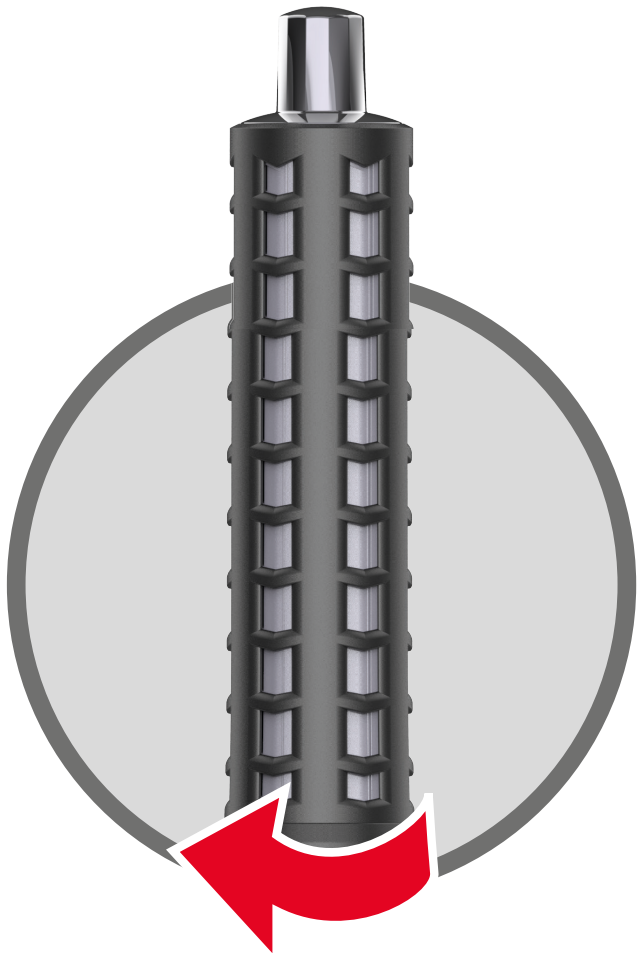

**38 mm Hair curler  
for bigger curls  
clockwise**



Recommended setting

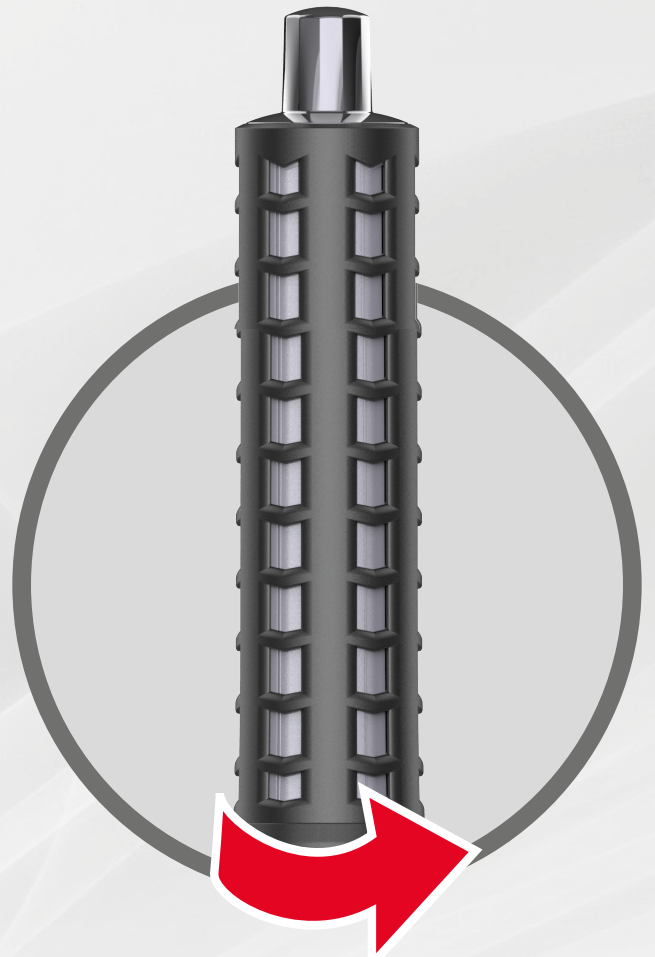
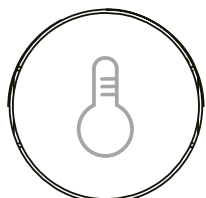
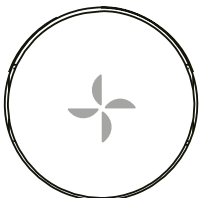

**38 mm Hair curler  
for bigger curls  
counterclockwise**

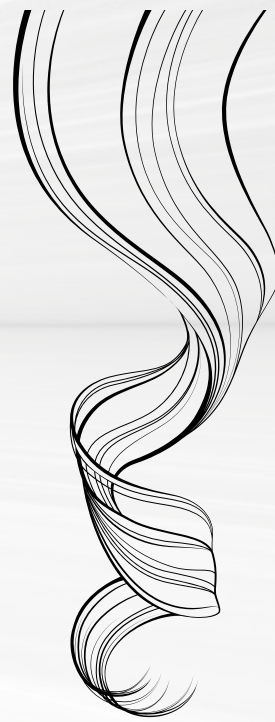

Recommended setting

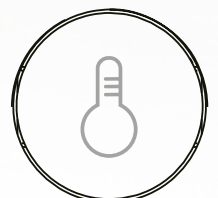
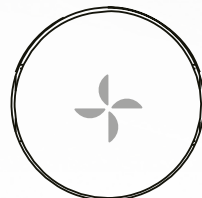



## Step by step

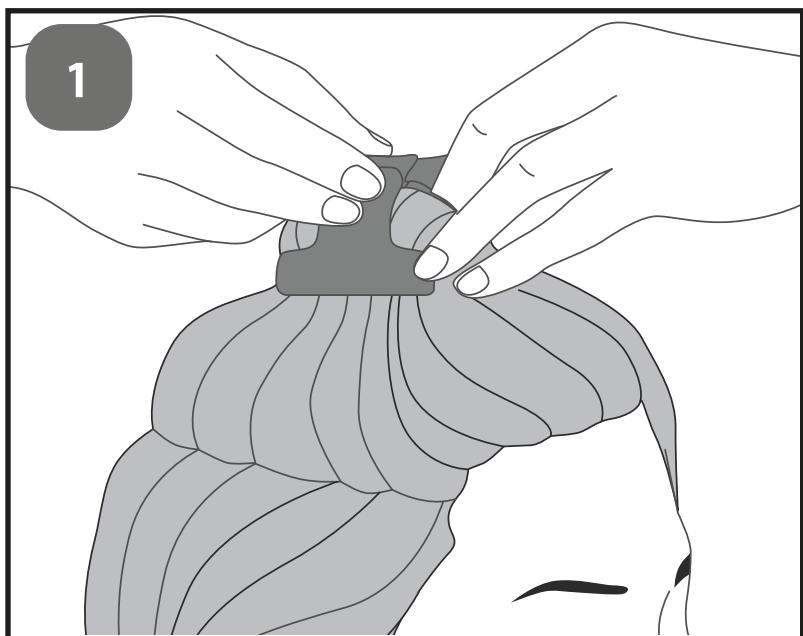

**It is best to work with slightly damp hair. Separate the top section of hair with a hair clip.**

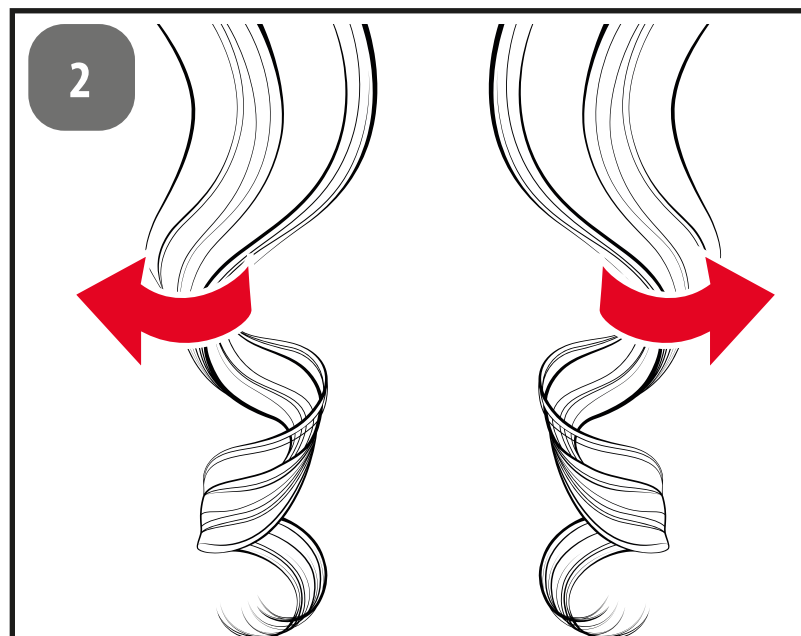

**Use the anti-clockwise hair curler for the left-hand side. For the right-hand side, select the one for clockwise curls.**

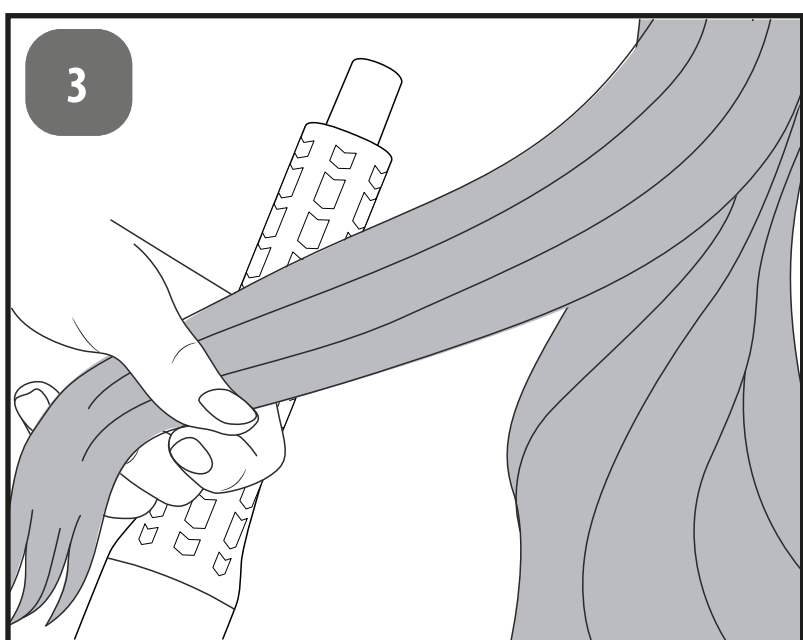

**Start with the first strand of hair of approximately the same length. Ideally with a width of around 1.5 - 2.5 cm. Hold the strand a little further up and let the ends hang down.**

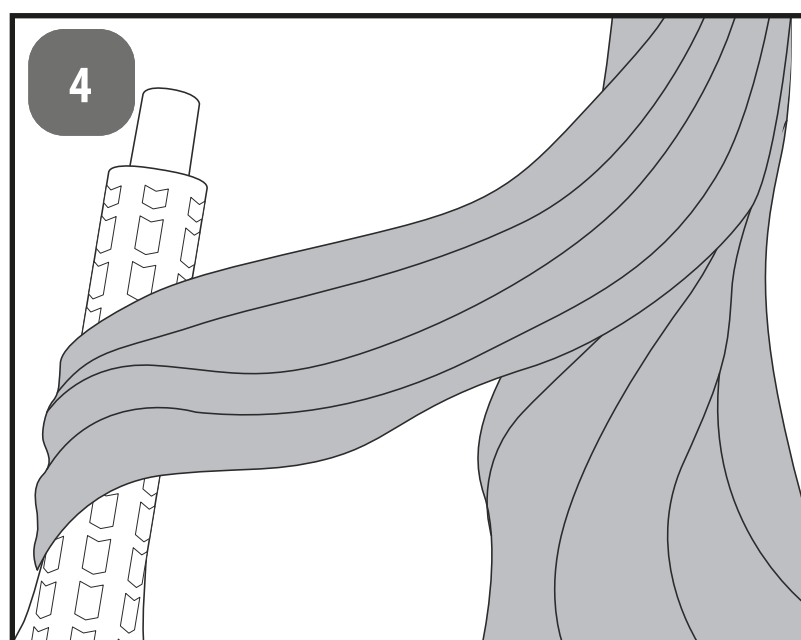

**Now turn on the "Supreme Style" and select the correct hair curler, along with your desired heat and strength settings. Hold the curler at the ends of the strand you wish to curl. The hair will automatically wrap around it.**

## Step by step

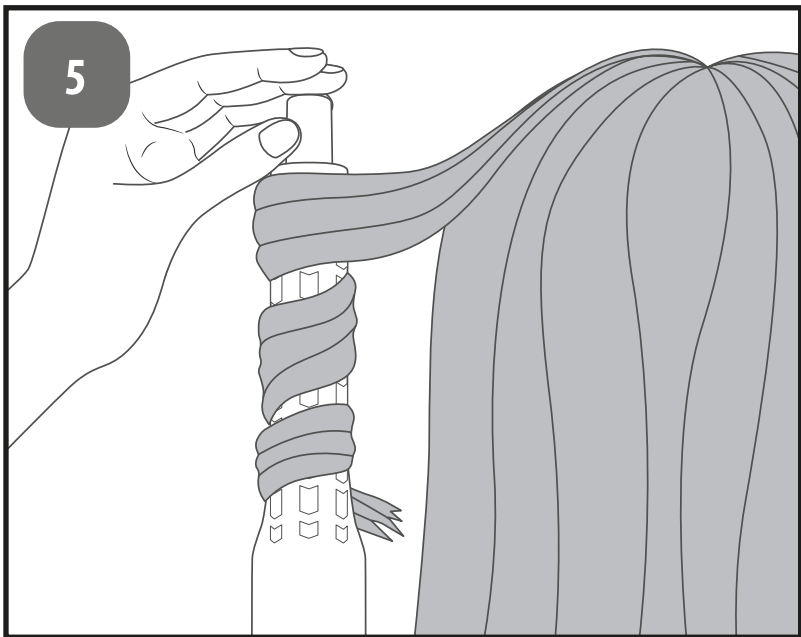

Once the ends have wrapped around the curler, release the strand and slowly move the curler towards the roots of your hair. The hair should naturally wrap around the curler as you do this; there's no need to twist it manually. Hold the curler in position for about 10 seconds at the end.

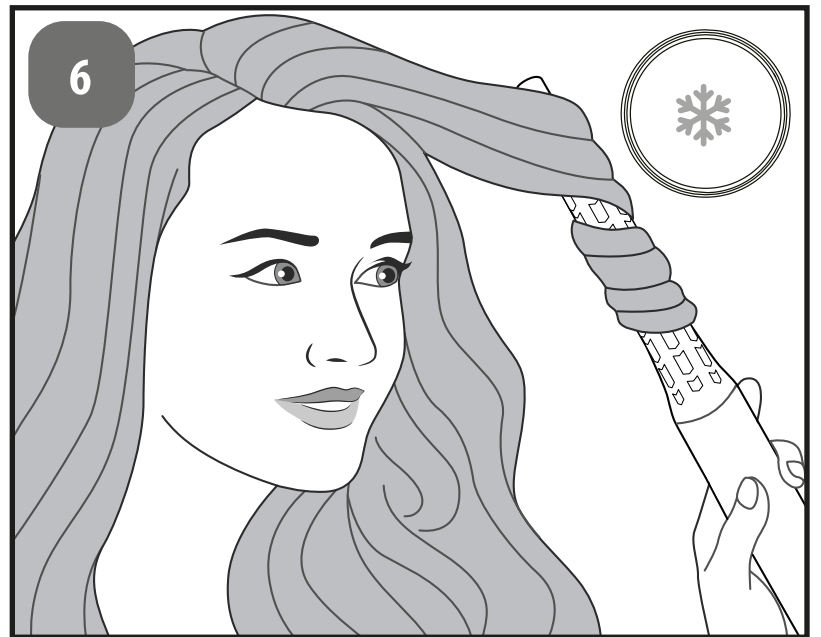

Next, activate the cool air function. Wait for another 10 seconds. Repeat the process until your hair is dry. Once done, turn off the device and gently pull it downwards. Use hairspray for a longer-lasting hold.

### Styling Tips

- If you encounter difficulties wrapping strands around the curler, try using smaller sections and make sure your hair isn't too wet.
- Use hair clips to keep hair you don't want to curl out of the way.
- Experiment with different levels of moisture to find what works best with your hair type.
- For curly or frizzy hair, straighten it first using the brush accessory before creating curls.





## Luxurious Waves

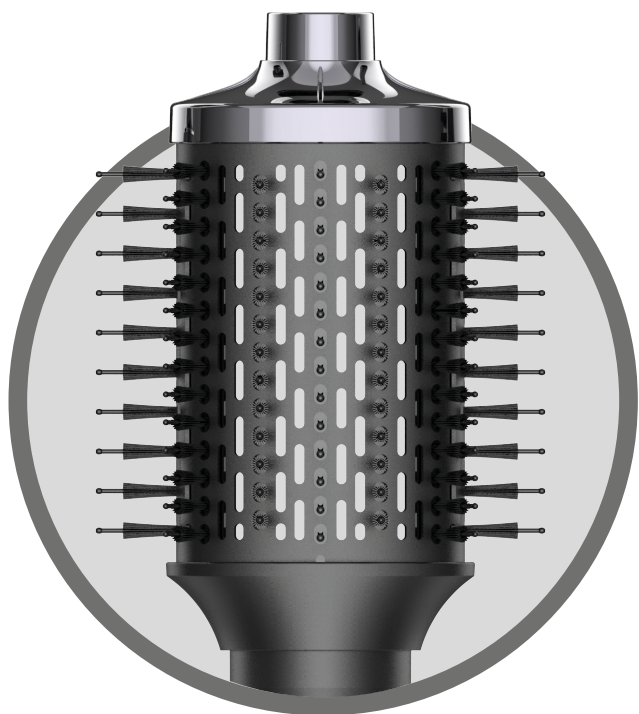

**Oval Brush**  
for voluminous curls

Recommended setting

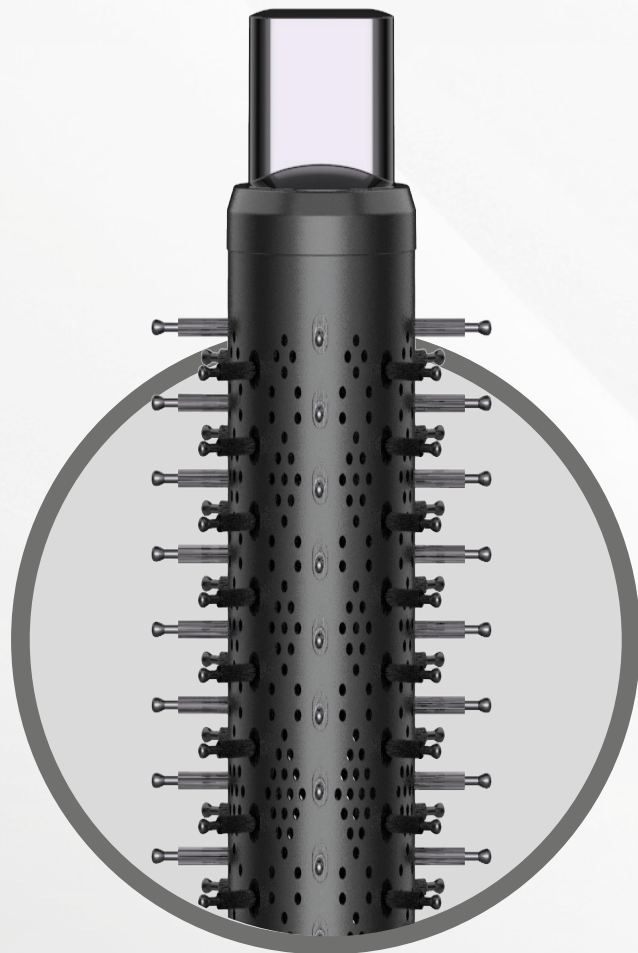
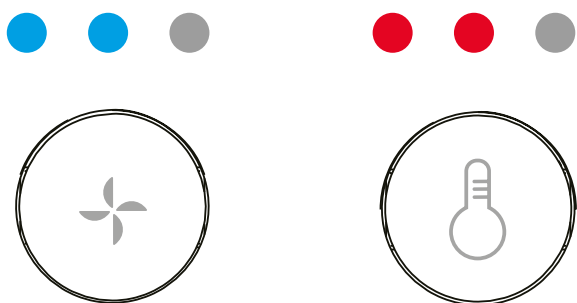

**Round Brush**  
for soft, smooth hair

Recommended setting

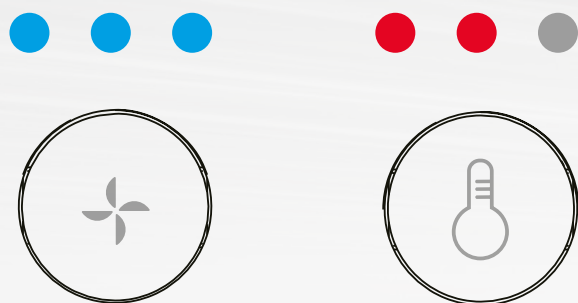

## Styling Tips

- For thin, fine hair, reduce the air strength.
- For thicker hair, increase the heat setting and try working with thinner strands.
- For stubborn, frizzy hair, increase the heat setting and, if necessary, repeat the process more often to achieve a smoother effect.
- To add more volume, hold the curler near the scalp under the hair and brush in circular motions upwards.

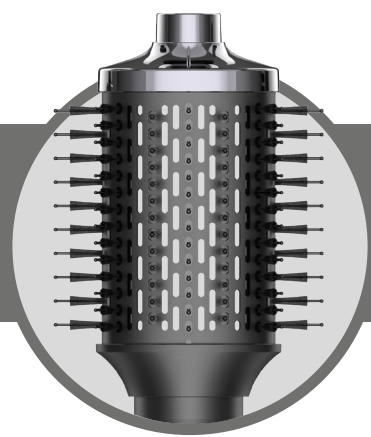

## Step by step

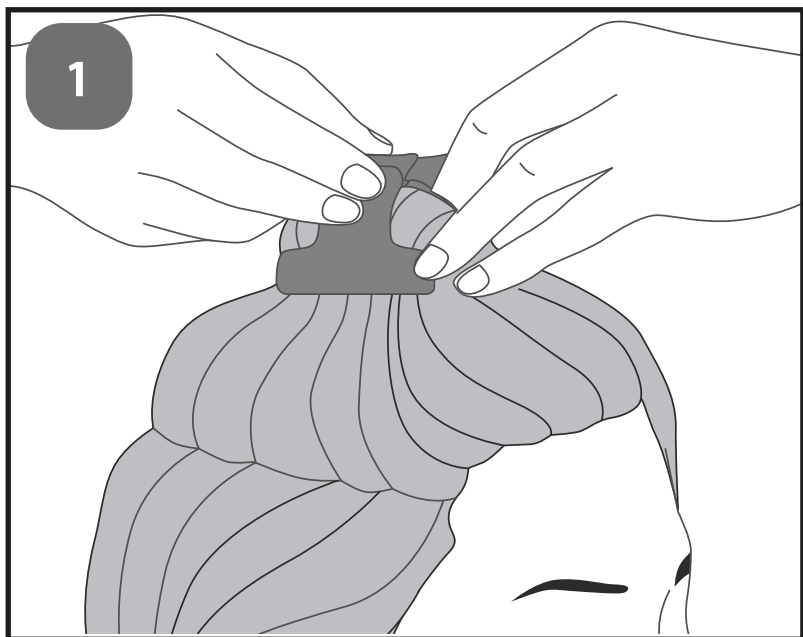

**1** Make sure your hair is towel-dried and pin sections if necessary. Start with the top, front-section and work your way back.

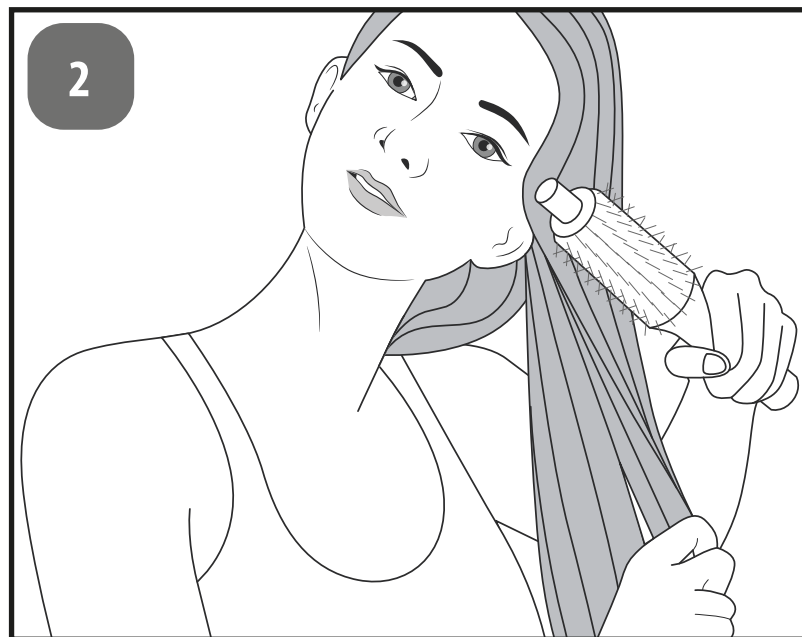

**2** For a voluminous blowout effect, hold the brush underneath the strand of hair close to the scalp. Start the appliance and hold it in place for about 3 seconds.



**3** Slowly pull the brush through the hair while turning it upwards. Repeat the process until all the hair has achieved the desired look.

Don't forget to use the cold air button at the end to calm the hair and prevent frizz.

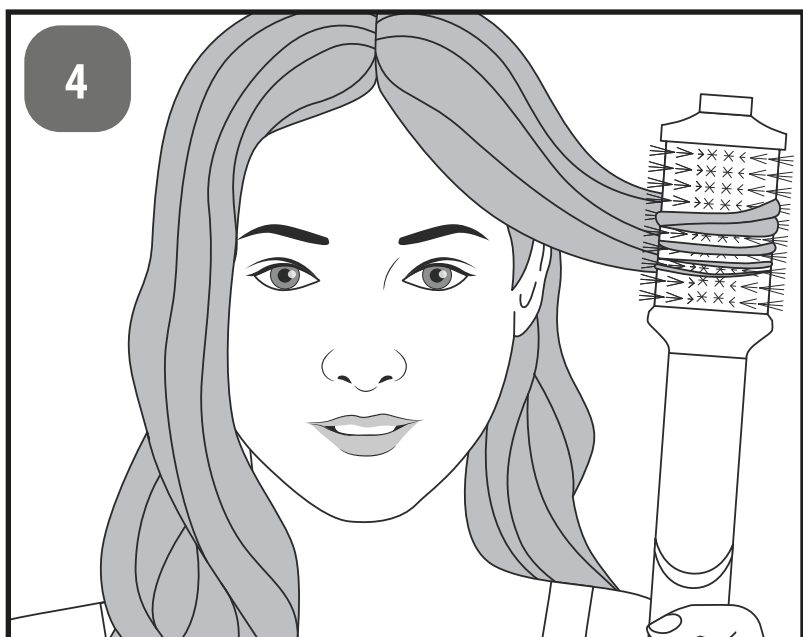

**4** For an additional curled effect, hold the brush below the end of the strand and wind it up to the roots. Then roll the brush carefully.

## Step by step

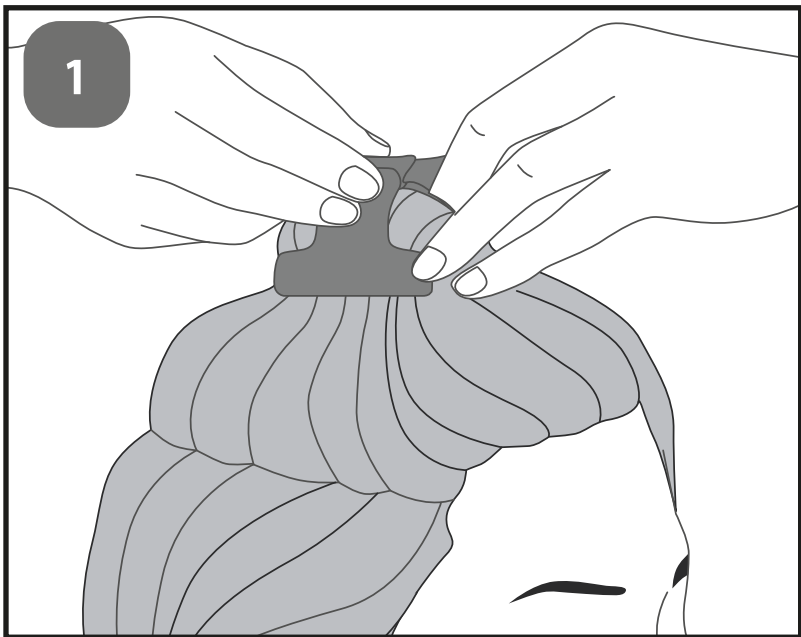
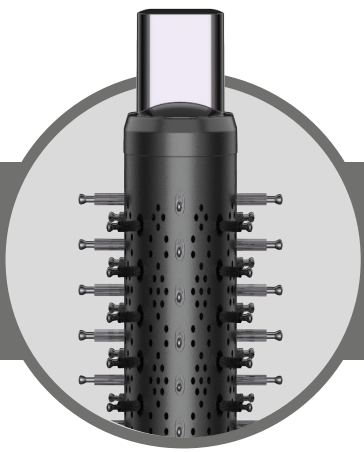

**1** Make sure your hair is towel-dried and pin sections if necessary. Start with the top, front section and work your way back.

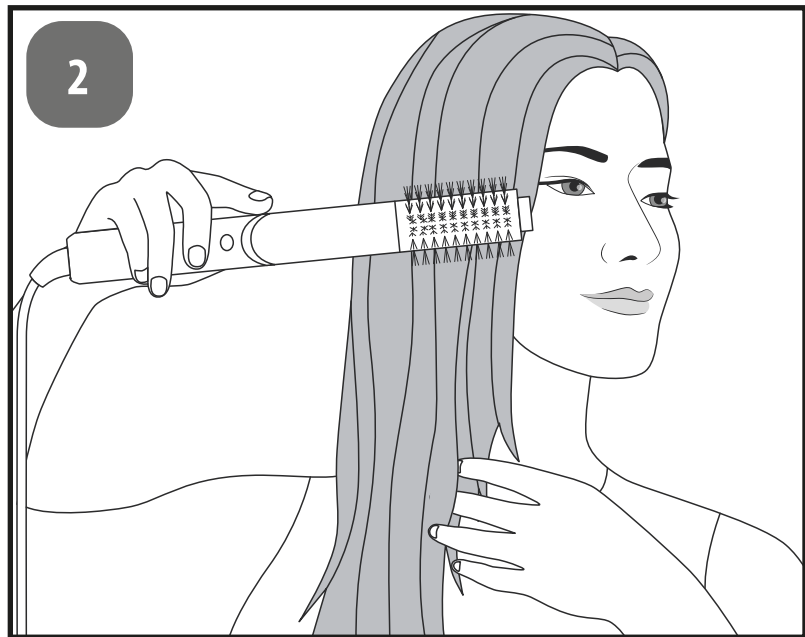

**2** Hold the round brush close to the scalp so that the bristles touch it. Switch the appliance on.

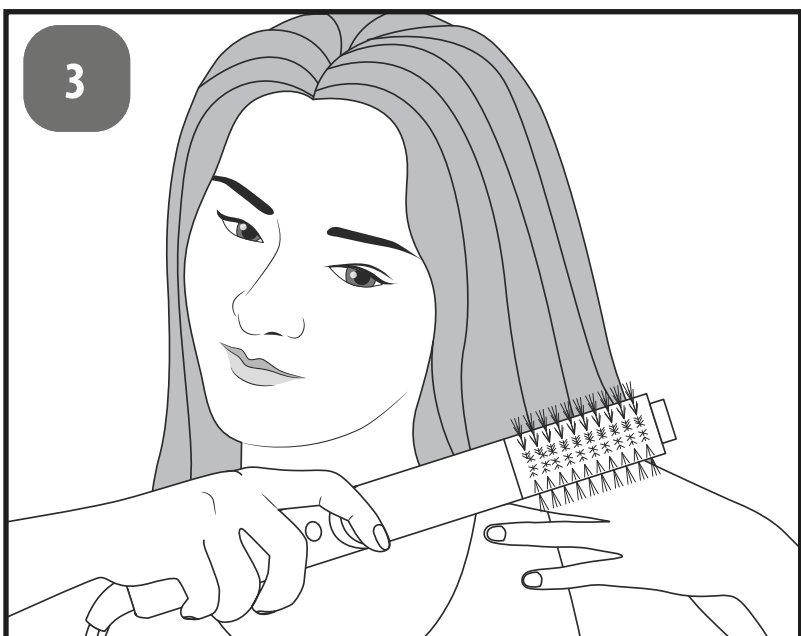

**3** Hold a strand at the ends with your middle and index finger and pull the round brush down through the hair. For a beautiful wavy mane, you can also twist the hair from the bottom upwards to create a slight wave shape.

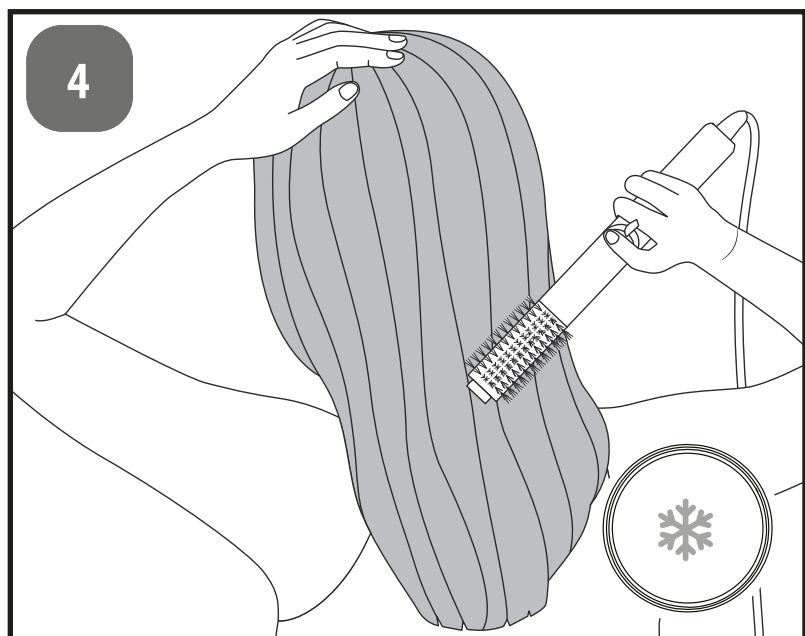

**4** Repeat the process until all the hair has achieved the desired look.

Don't forget to use the cold air button at the end to calm the hair and prevent frizz.

*Supreme in every way.*





## The Sleek-Look



**Drying accessory**  
for smooth, sleek hair

Recommended setting

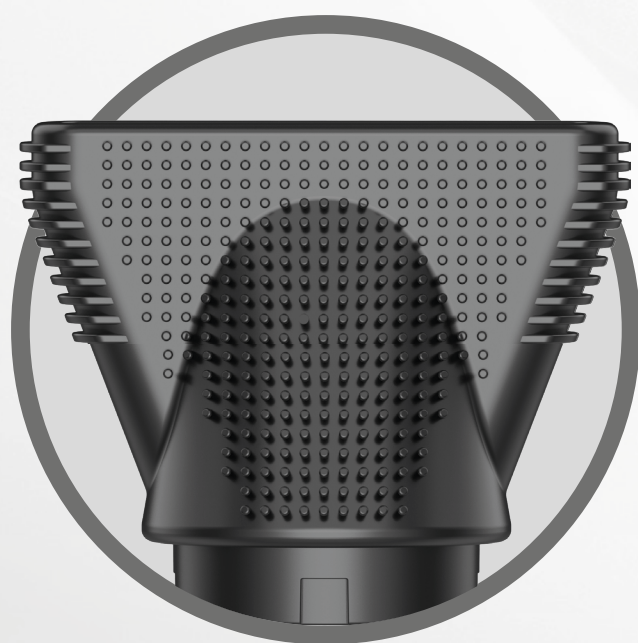
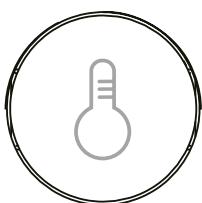
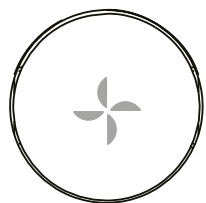

**Styling nozzle**  
for precise, smooth styling

Recommended setting

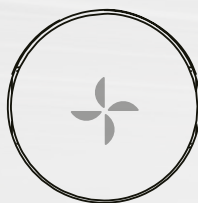

## Styling Tips

- Hold the strands at their ends and gently pull them to achieve a smoother effect.
- Additionally, use a comb between the steps.



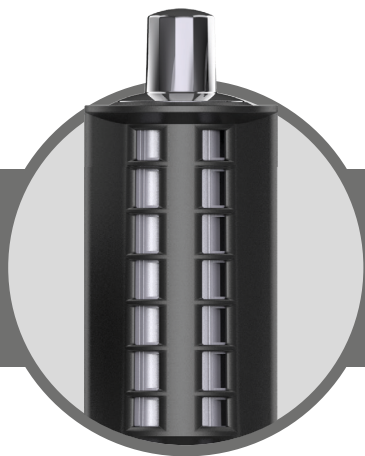

## Step by step

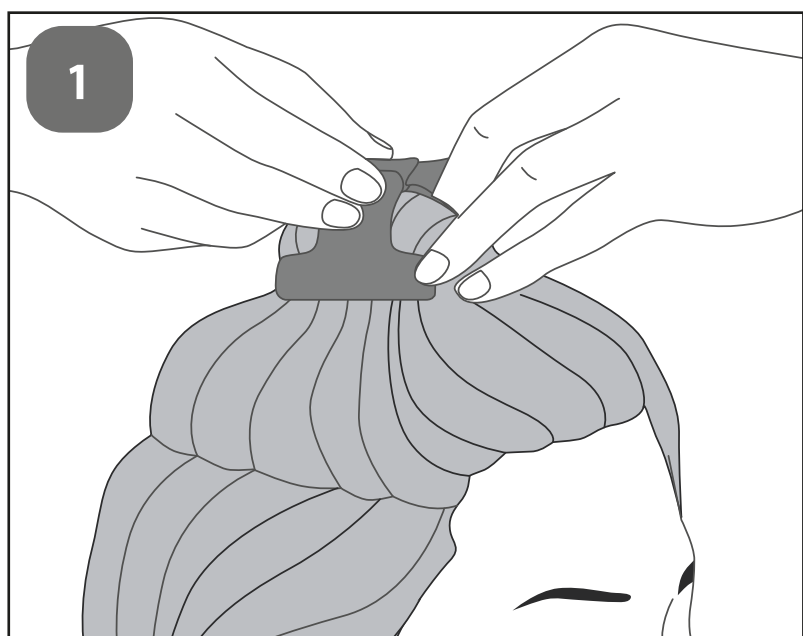
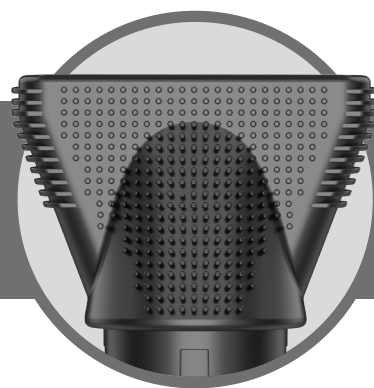

**It is best to work with slightly damp hair. Separate the top section of hair.**



**For a sleek look, first use the styling nozzle and make use of the flexible joint.**

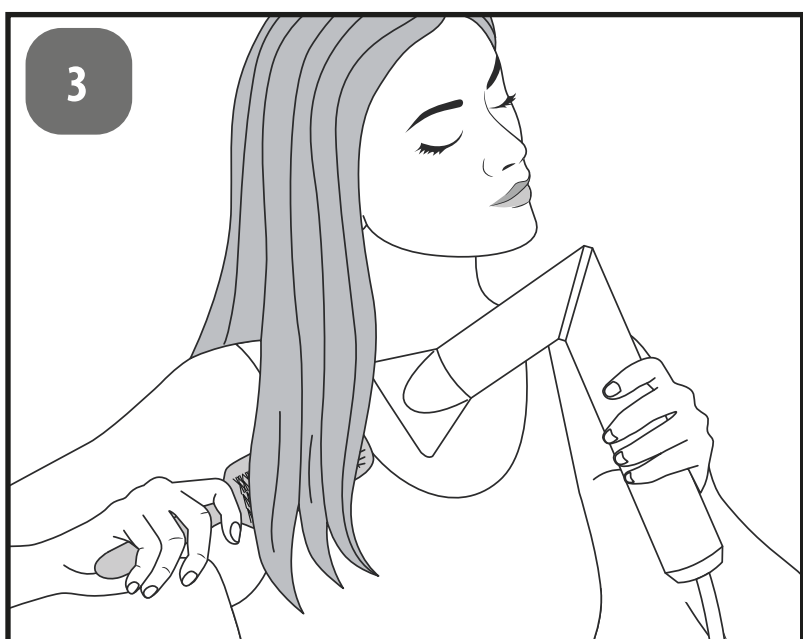

**Begin by working on individual sections of hair from top to bottom with the hairdryer.**

**For a wavy look, you can also wrap your hair around a round brush and dry it with the nozzle.**

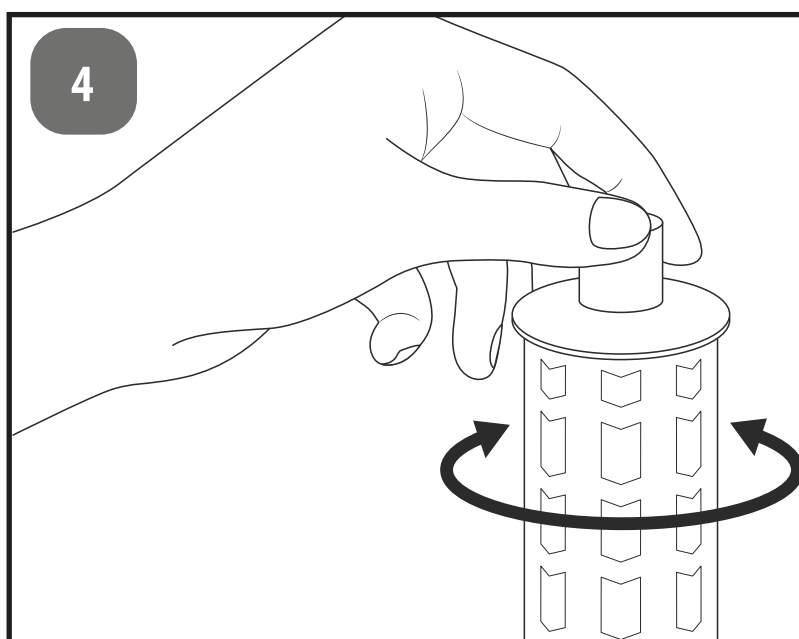

**Select the wind direction of the drying accessory. Ensure that the hair is completely dry. Hold the accessory close to the hair and slowly pull the device from top to bottom. Repeat the process if necessary.**

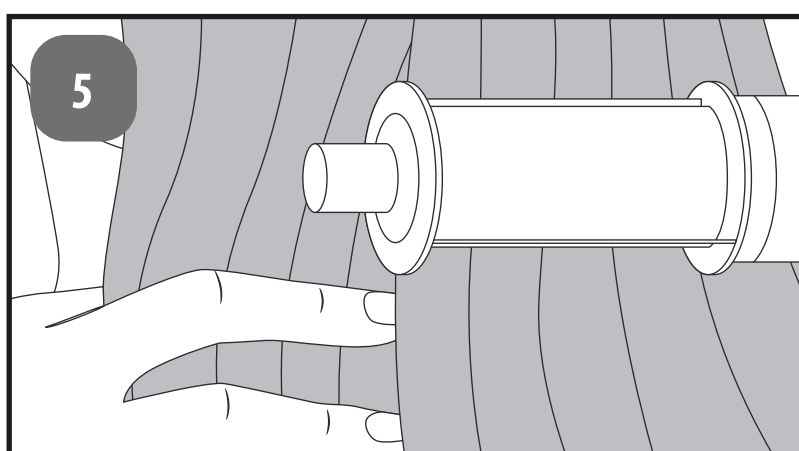



*Voluminous mane*



### Diffuser for natural volume

#### Recommended setting

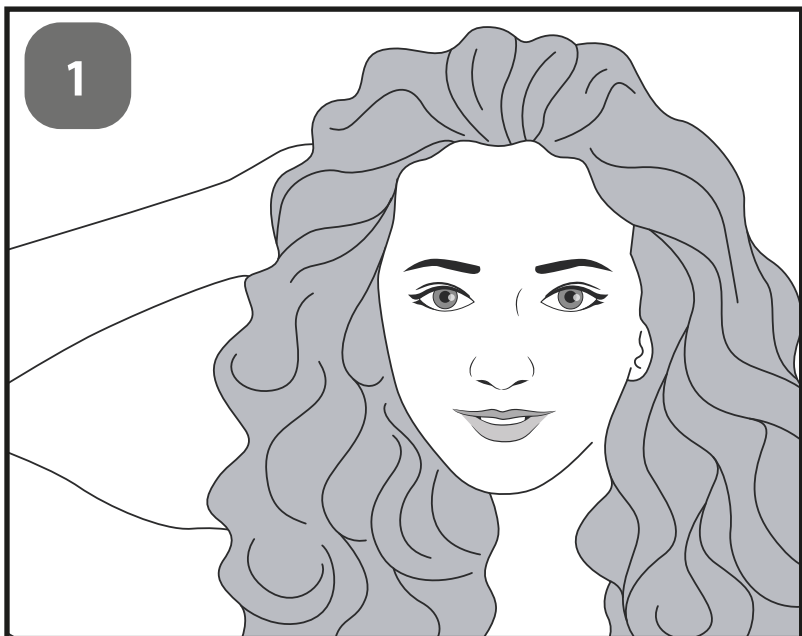
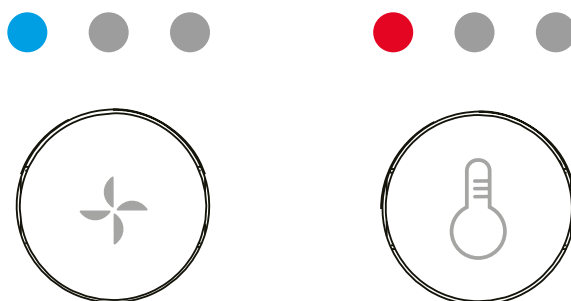

**Begin with towel-dried, loose hair, or hair that is already curled.**

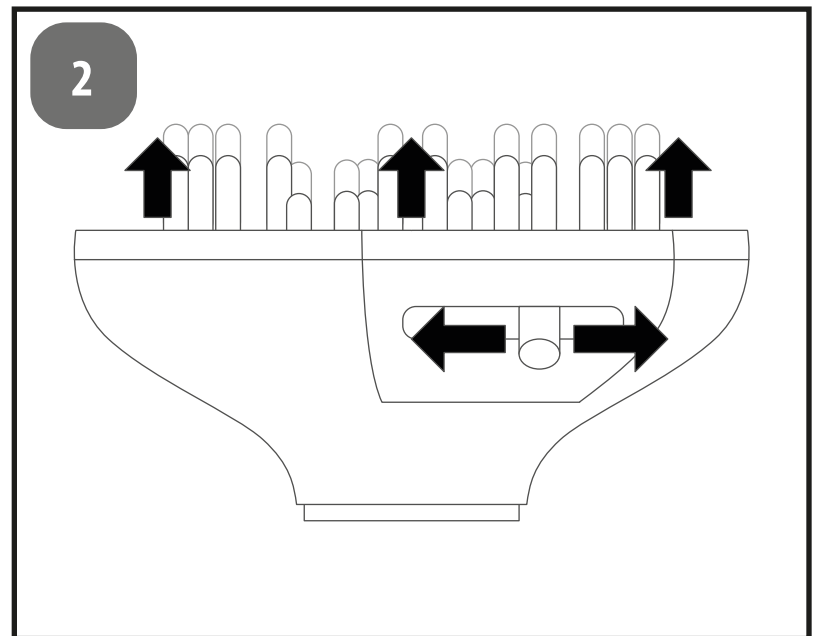

**You can adjust the length of the diffuser fingers by sliding the regulator left or right.**



## Step by step

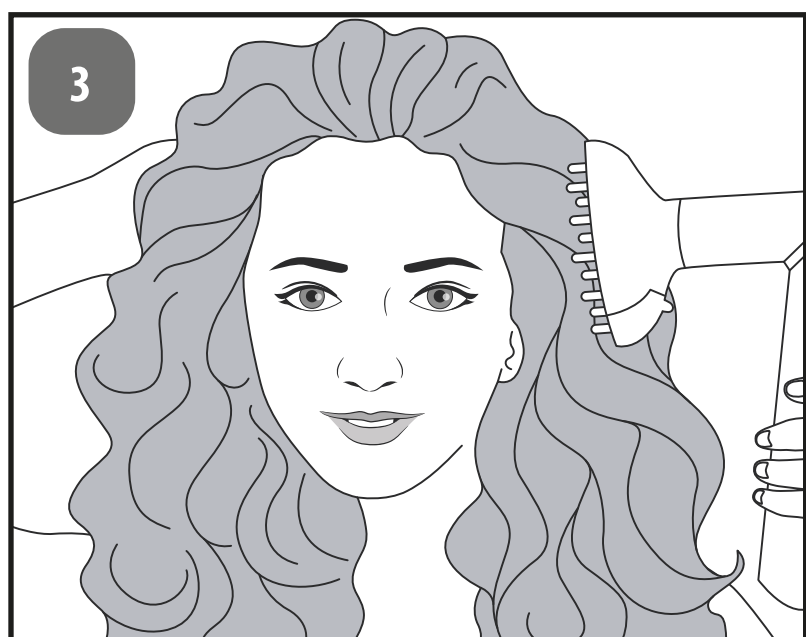

Place a strand or section of hair onto the diffuser and slowly move it towards the scalp. Hold it in this position for a few seconds, then gently remove it.

For even more volume, start with the diffuser fingers shortened and extend them at the scalp.

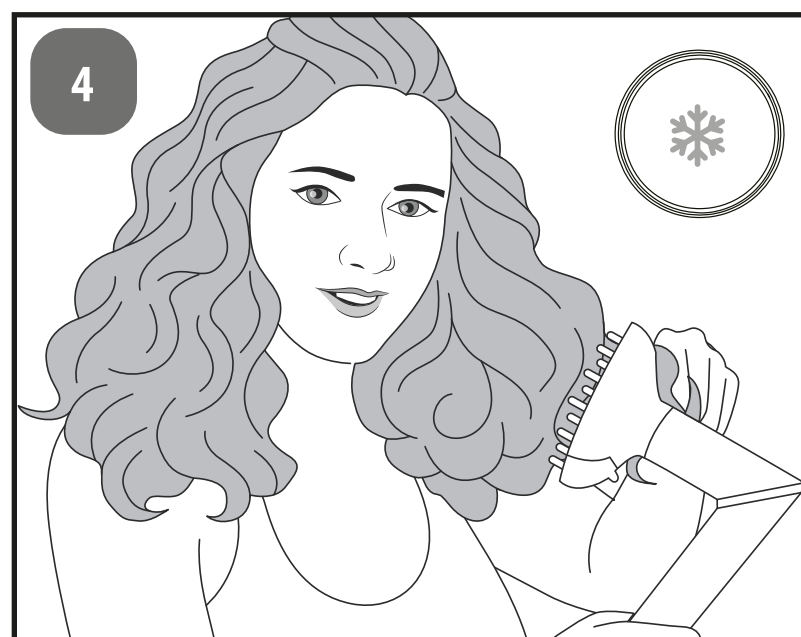

Once the hair is almost dry, use the cool air button while continuing to use the diffuser. The cool air helps to set the volume and gives the hair a fresh feel.

## Styling Tips

- Applying appropriate hair care products beforehand can help prevent frizz.
- For thicker hair, consider using a higher heat setting.
- Short, pulsing movements help gently lift and dry the hair. This promotes volume and reduces frizz.
- Once the hair is dry, shape it by hand and use a finishing product to complete the look.





## *Styling secrets*

### **1. The foundation of a perfect styling**

**Preparation is key:** Always start with clean, detangled hair. A heat protectant can help shield your hair from damage and achieve a smoother finish.

**Temperature selection:** Choose lower temperatures for fine hair, while thick or curly hair may require higher temperatures.

### **2. Curls like a pro**

**Beach waves:** Wrap the hair around the curling attachment in alternating directions for casual, beach-like waves.

**Classic curls:** Wrap the hair evenly and in the same direction for uniform, elegant curls.

### **3. Smooth hair without frizz**

**Segmentation:** Divide your hair into sections and straighten each section individually for a more even result.

**One pass is enough:** Glide the multistyler slowly and steadily through your hair to avoid overheating and the need for multiple passes.

### **4. Volume at the roots**

**Lift the roots while drying or styling with the round brush to achieve more volume at the base.**

### **5. Maintain your style**

**A light hairspray can help keep your look in place all day without weighing down your hair.**

### **6. Secret tip for more shine**

**Finish your styling with a cool blast of air. This closes the hair cuticles and gives your hair a natural shine.**

## *Styling secrets*

### **7. Experiment with textures**

Use the multistyler to style only certain sections of your hair to create interesting textures and looks.

### **8. Post-styling care**

A hair oil or serum can help nourish your hair and add shine after styling.

### **9. Multistyler for short hair**

Even with short hair, you can create great looks with the “Supreme Style”. Experiment with waves, curls, or simply adding volume at the roots.

### **10. Longer lasting curls**

After creating a curl, let it cool in your hand before releasing it. This helps set the curl and maintain its shape for longer.





## *Hair Care Supreme*

### **Gentle Shampoo**

**Use a mild shampoo that is free from harsh chemicals and sulfates. This prevents the hair from becoming overly dry.**

### **Conditioner**

**A good conditioner helps detangle hair, restore moisture, and keep it smooth.**

### **Gentle Brushing**

**Use a soft brush and be especially careful when hair is wet, as it is most prone to breakage at this time.**

### **Nutrition**

**A balanced diet rich in protein, vitamins, and minerals can promote hair growth and keep your hair healthy.**

### **Sleeping on Silk**

**A silk pillowcase can reduce hair breakage and prevent hair from knotting overnight.**

### **Sun Protection**

**Excessive sun exposure can dry out and fade your hair. Use products with UV protection or wear a hat when spending extended time in the sun.**

### **Gentle Styling**

**Avoid hairstyles that pull or strain the hair tightly, such as very tight braids or ponytails.**

### **Avoid Chlorine**

**When swimming, wear a swimming cap or immediately rinse your hair after swimming in chlorinated water.**

# Contact us



If you encounter any issues or have questions about our “Supreme Style” and its use, please contact Trisa Electronics before reaching out to your retailer.

## Opening hours of Trisa Electronics

Mo-Fr: 08:00 - 11:45  
13:30 - 17:00

Trisa Electronics AG  
Kantonsstrasse 121  
CH-6234 Triengen

info@trisaelectronics.ch  
+41 41 933 00 30



Information & downloads of digital instructions can be found at  
[www.trisaelectronics.ch/supremestyle](http://www.trisaelectronics.ch/supremestyle)

***Trisa***®  
E L E C T R O N I C S