

Concrete Production

EXTRABEND® and EXTRACURVE® Pipe Elbows

23 24



Description ▼

Short-radius EXTRABEND® and wide-radius EXTRACURVE® Pipe Elbows are inserted as a link in pneumatic silo filling pipes. Both models are manufactured from a one-piece SINT™ engineering polymer cast.

Wear-resistant EXTRABEND® and EXTRACURVE® Pipe Elbows deflect incoming cement, filler dust or microsilica minimising material degradation and elbow wear, avoiding at the same time any clogging or plugging.

Function ▼

The EXTRABEND® short-radius Pipe Elbow offers a substantially innovative geometry suitable to reduce wear during operation.

The body cavity next to the point of diversion generates an internal material turbulence which protects the elbow from wear caused by the material travelling through the duct.

The EXTRACURVE® represents the latest evolution in the development of wide angle pipe elbows. Due to its flexibility and adaptability installation has become quicker while durability is dramatically increased.



Application ▼

EXTRABEND® and EXTRACURVE® Elbows are used as a link in silo filling pipes and in ductworks of pneumatic conveying systems. They excel through their particular resistance to wear with abrasive materials.

Benefits ▼

- ✓ Long-life elbow with abrasive materials thanks to anti-wear SINT™ engineering polymer material;
- ✓ Reduced installation costs thanks to elastic properties (no extra work for connection on site is needed);
- ✓ Reduced installation and maintenance time because EB/EW are easy to handle thanks to lightweight design;
- ✓ Reduced costs for plant designing thanks to elastic properties (elastic elbows fit for different plant layouts);
- ✓ Considerable reduction of flow resistance, consequently energy saving pneumatic conveying.

Concrete Production

EXTRABEND® and EXTRACURVE® Pipe Elbows



Technical Features / Performance ▼

- ▶ SINT™ engineering polymer
- ▶ Range from 2" to 4"
- ▶ PN-type connecting flanges
- ▶ Up to 1.5 bar (22 PSI) in lean phase
- ▶ Max temperature : 80° C (176° F)
- ▶ Flexible and elastic
- ▶ Lightweight and easy to handle
- ▶ Reduced noise level

Overall Dimensions ▼

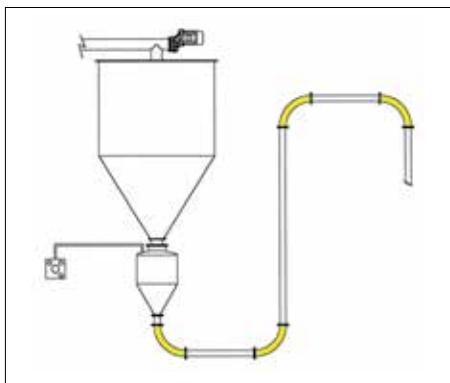
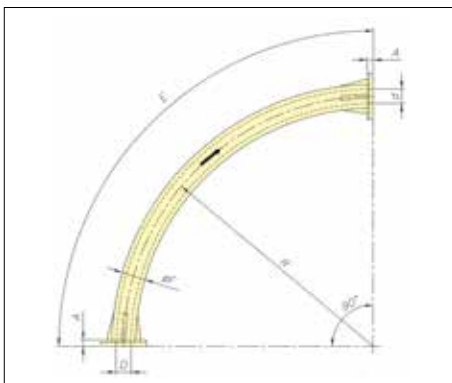

EXTRACURVE®

EW	A	Ød	ØD	E	ØF	R	kg
2"	23	52	55	1,400	85	900	7.3
3"	30	80	83	1,400	110	900	9.6
4"	30	105	108	1,400	140	900	13.4

Dimensions in mm

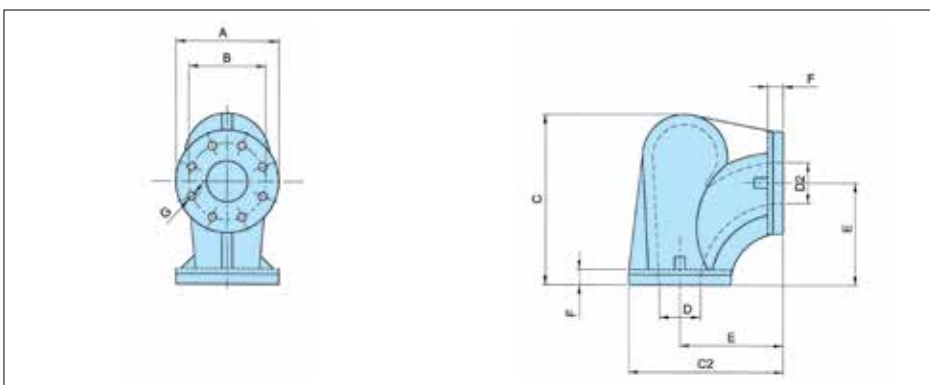

EXTRABEND®

Type	Ø Pipe	A	B	C	C2	Ø D	Ø D2	E	F	Ø G	Flange Drillings	kg
EB 2	2"	165	125	232	220	55	52	140	23	18	4	2
EB 3	3"	200	160	330	300	85	80	200	30	18	4	5
EB 4	4"	220	180	435	373	108	105	263	30	18	8	7

Dimension in mm

DS_110_EWEB_EN/March 2014_000 Rights reserved to modify technical specifications.

This datasheet does not show the complete range but only the models most suitable for the application.



www.wamgroup.com