

CON-E-CO®

An Astec Industries Company



G12L

concrete batch plant

G12L DECUM

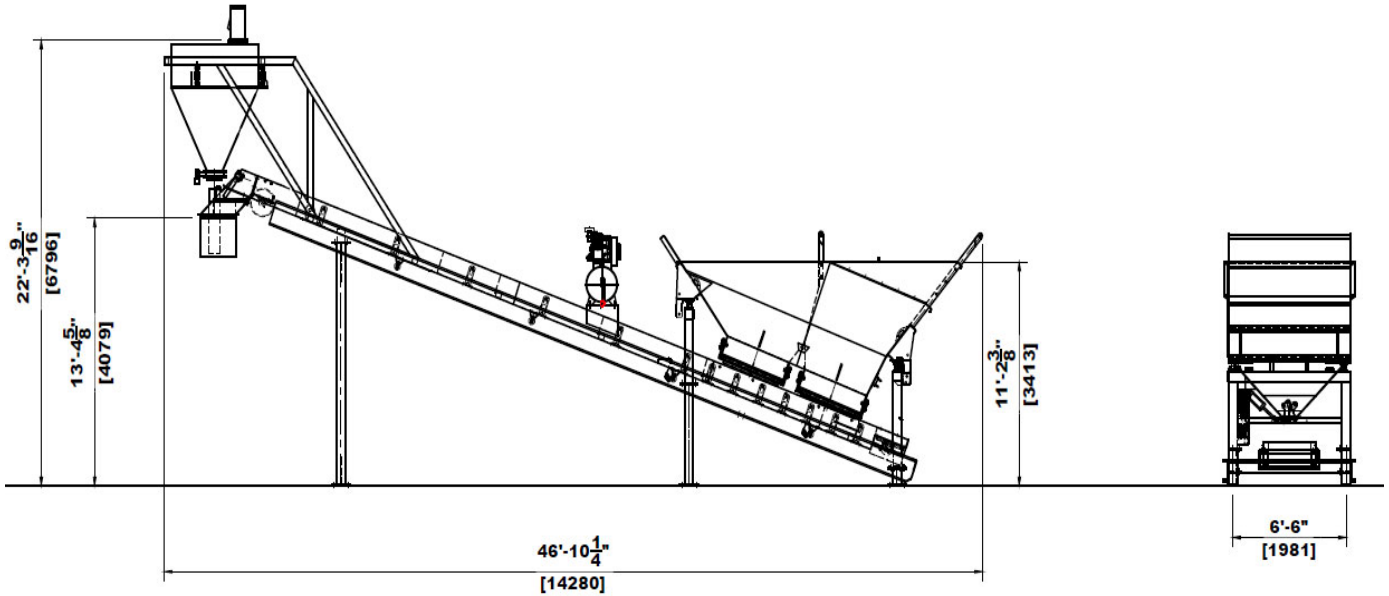

SPECIFICATIONS

PRODUCTION CAPACITY:

Theoretical Cycle Time - 2.5 to 3 minutes

AGGREGATE WEIGHING BIN CAPACITY:

477 cubic feet (13.5 cubic meters)

Scales - Direct Load Cells

2 compartments with option up to 4 compartments or 2 individual weigh bins

CEMENT BATCHER CAPACITY:

12 cubic feet (3.4 cubic meters)

Scales - Direct Load Cells

AGGREGATE DISCHARGE CONVEYOR:

24" wide (610 mm), 10 horsepower drive.

Optional 30" (762 mm), 15 horsepower drive.

HIGH PRESSURE AIR COMPRESSOR:

5 horsepower, 80 gallon (302 Liter).

Optional 10 horsepower, 80 gallon (302 Liter).

ELECTRICAL:

3-phase with 120 VAC transformer for control voltage. All motors are TEFC. All motor circuit wiring protected by individual circuit breakers. Electrical components housed in NEMA steel enclosures. Wiring in conduit.

BATCH CONTROL SYSTEM:

Semi-automatic cut-off of cement by presets on digital readouts. Push-button for electric over air on gates. Optional fully automatic computerized batch control system.

WATER METER:

3" diameter (77 mm) with up to 500 gallons (1,740 liters) per minute.

TRANSPORTATION SYSTEM:

Ships on a tractor trailer. Optional rear-mounted 19,000 lb. (9,090 kg) capacity single axle with four (4) 295/75R 22.5 tires, wheels, air brakes heavy duty spring suspension, tail and brake lights, and fifth wheel rub plate with king pin.

OPTIONAL CEMENT SILO AND FEEDER SCREW CONVEYOR:

Cement Silo - 1,600 cubic feet (45 cubic meters) ground mount.

Cement Silo - 1,400 cubic feet (39.5 cubic meters) containerized.

Feeder Screw Conveyor - 6" diameter (152mm), 10 horsepower drive x 25'-0" (7.62 m) or 9" diameter (229 mm), 20 horsepower or 12" diameter (305 mm), 30 horsepower. Includes bag breaker hopper for 1 cubic foot (0.3 cubic meter) bags or an optional 4'-0" (1.22 m) x 4'-0" (1.22 m) for super bags.

DIMENSIONS:

Towing length..... 38'-1" (11,593 mm)

Towing height..... 13'-4" (4,088 mm)

Towing width..... 7'-6" (2,286 mm)

Empty weight, total..... 22,000 lbs. (9,979 kg)

SHIPPING DIMENSIONS:

Length 47'-4" (14,426 mm)

Height 9'-2" (2,792 mm)

Width 7'-6" (2,286 mm)

Shipping Volume 3,254 cubic feet (92 cubic meters)

237 North 13th Street - Blair, Nebraska 68008 - 402-426-4181 - Fax 402-426-4180 - www.con-e-co.com

sales@con-e-co.com

PROUD MEMBER OF



CON-E-CO.
SOLID PRODUCTS. SOLID PERFORMANCE