

CON-E-CO[®]

An Astec Industries Company

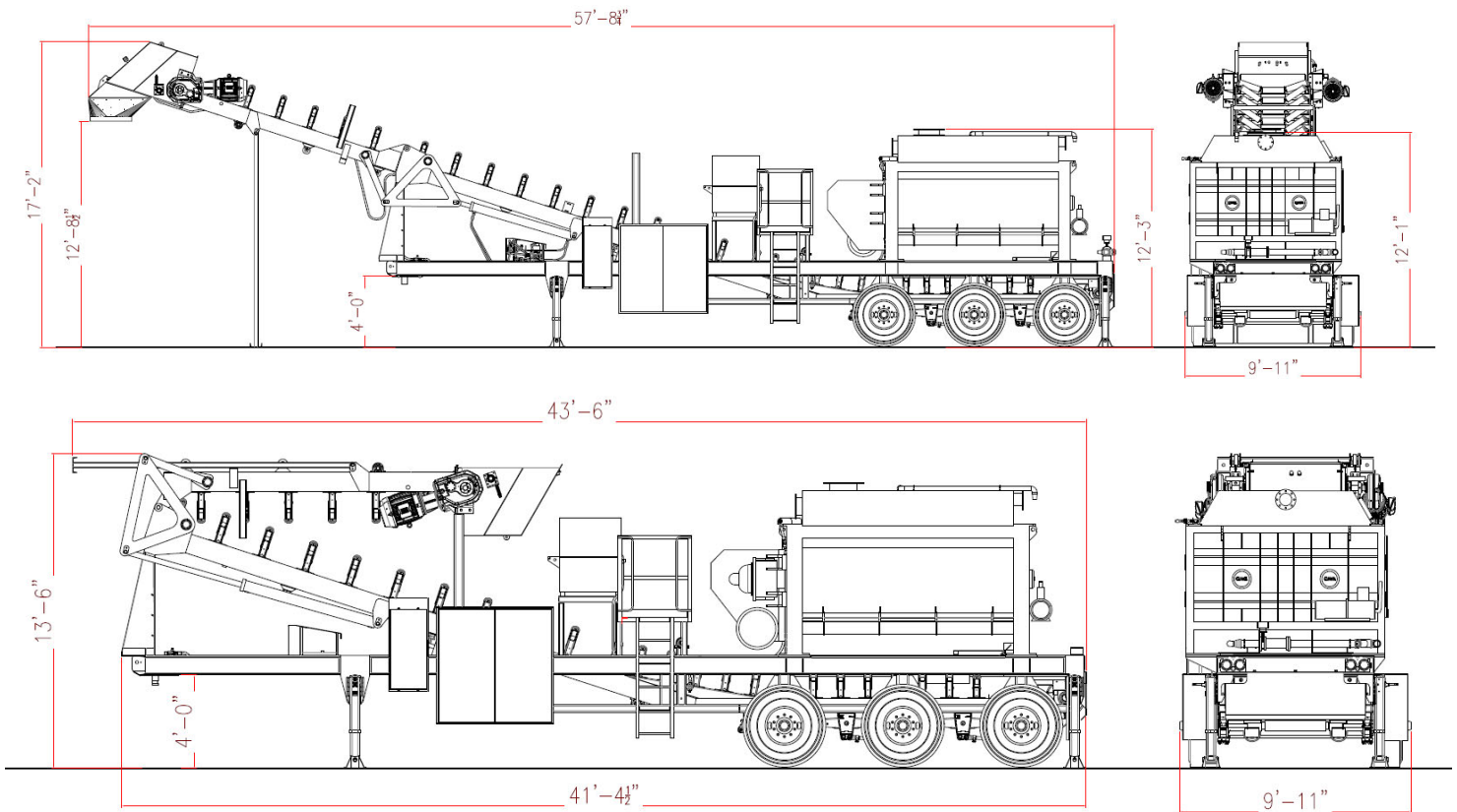

MOBILE TWIN SHAFT



SPECIFICATIONS

CONVEYOR TRANSPORTATION SYSTEM

MIXER CHARGING HEIGHT:

12'-3"

DISCHARGE HEIGHT:

12'-8"

DISCHARGE CONVEYOR:

42" wide (1,066 mm), 50 horsepower drive (dual 25 horsepower)

TRANSPORTATION SYSTEM:

Tandem axle (MAO 6000/4000 and MAO 7500/5000)

Triple Axle (MAO 9000/6000 and MAO 12000/8000)

Wheels, air brakes, heavy duty spring suspension, tail and brake lights, and fifth wheel rub plate with king pin.

ELECTRICAL:

460 volt, 3-phase with 120 VAC transformer for control voltage. All motors are TEFC. All motor circuit wiring protected by individual circuit breakers. Electrical components housed in NEMA steel enclosures. Wiring in conduit. UL Listed Panel.

DIMENSIONS:

Towing length..... 39'-11" (12,167 mm)

Towing height..... 13'-6" (4,115 mm)

Towing width..... 9'-11" (3,023 mm)

Empty weight, total..... 52,000 lbs. (23,587 kg) MAO 7500/5000

SICOMA MIXER SIZES AVAILABLE:

MAO 6000/4000

5.33yd³ (4m³)

MAO 7500/5000

6.6yd³ (5m³)

MAO 9000/6000

8yd³ (6m³)

MAO 12000/8000

10.5yd³ (8m³)

DISCHARGE GATE:

Hydraulically operated Single Discharge Door, optional Double Discharge Doors (Standard on Model 12000/8000)

LUBRICATION SYSTEM:

Automatic central lubrication system.

HIGH PRESSURE WASHOUT SYSTEM:

20 horsepower (MAO 6000/4000 and MAO 7500/5000)

30 horsepower (MAO 9000/6000 and MAO 12000/8000)

OPTIONAL TEMPER WATER:

3" diameter (77 mm) water meter with slump meter.

SHIPPING DIMENSIONS:

Length 43'-6" (13,259 mm)

Height 13'-6" (4,115 mm)

Width 9'-11" (3,023 mm)

Shipping Volume 8,814 cubic feet (165 cubic meters)

237 North 13th Street - Blair, Nebraska 68008 - 402-426-4181 - Fax 402-426-4180 - www.con-e-co.com

sales@con-e-co.com

PROUD MEMBER OF



CON-E-CO
SOLID PRODUCTS. SOLID PERFORMANCE