



# Pixel 9a Recycling Guide

Version 1.0



# Environmental sustainability at Google

**At Google, operating in an environmentally sustainable way has been a core value from our beginning.**

As our business has evolved to include the manufacturing of electronic products, we've continually expanded our efforts to improve each product's environmental performance and minimize Google's impact on the world around us.

This report details how recyclers can disassemble the Pixel 9a to recover raw materials.

To provide feedback or for questions about this guide, please email [Recycling@Google.com](mailto:Recycling@Google.com).

## Who is this Guide for?

**This guide is intended for professional recyclers who are trained in electronics recycling and understand the risks involved with doing so. This recycling guide is not intended in any way to serve as repair instructions.**

Please follow all relevant local-federal regulations and applicable international standards for electronic recycling as you follow this guide.

# Table of Contents

Topic	Location
Components Requiring Selective Treatment	<a href="#">Slide 4</a>
How Best to Approach Device End-of-Life	<a href="#">Slide 5</a>
General Personal & Environmental Safety	<a href="#">Slide 6</a>
Battery Safety	<a href="#">Slide 7</a>
Expanded View of Device	<a href="#">Slide 9</a>
Location of Battery	<a href="#">Slide 10</a>
Screw Map	<a href="#">Slide 11</a>
Material Constituents of Device	<a href="#">Slide 12</a>
Recommended Tools	<a href="#">Slide 13</a>
Processing Steps	<a href="#">Slides 14 - 26</a>
Frequently Asked Questions	<a href="#">Slide 27</a>

# Directive 2012/19/EU Annex VII Components Requiring Selective Treatment

The Google Pixel smartphone contains the following materials and components as listed in Annex VII in the European Union WEEE (recast) Directive 2012/19/EU.

Substance or Component	Location	Removal Instructions
<b>Display &amp; Cover Glass</b> Cover glass and organic light-emitting diode (OLED) display if the surface is greater than 100 cm <sup>2</sup>	Main Display	<a href="#">Step 13</a>
<b>PCB</b> Printed circuit board if the surface area is greater than 10 cm <sup>2</sup>	<b>Main Logic Board</b> This device employs a mid-frame architecture. MLB is located within the device enclosure and can be accessed through the back cover.	<a href="#">Steps 1 - 8</a>
<b>PCB</b> Printed circuit board if the surface area is greater than 10 cm <sup>2</sup>	<b>OLED FPC</b> Organic light-emitting diode flexible printed circuit	<a href="#">Step 1 - 8</a>
<b>Battery</b>	<b>Battery</b> Battery is located within the device enclosure and can be accessed through the back cover.	<a href="#">Steps 1 - 6</a>
<b>Charger</b> External electric cables	<b>Charge Cable</b> External charging cable is removable.	<a href="#">Step 1</a>

## Give Your Device New Life

Before you recycle this device to recover materials, please consider whether the useful lifespan of this device can be extended in other ways.

Repair your device



[Link](#)

Trade-In your device



[Link](#)

Sell your device



[Link](#)

Google Mail-In  
Take-Back Program



[Link](#)

---

## Recycle Properly

Again, this guide is intended for technicians and operators who are trained in electronics recycling and understand the risks involved with electronic recycling.

If you are not trained, equipped and capable of properly recycling this device, please use Google's complementary take back program.

## Personal Safety

Operators should always wear personal protective equipment (PPE) including protection from thermal events, fires and hazardous materials.

Hand protection



Protective Clothing



Eye protection



Burn Protection



Breathing protection



HazMat Protection



## Environmental Health & Safety

Operate in a safe, well-ventilated environment. Follow safety and ergonomic best practices. Outfit your workspace with fire and hazardous material mitigation equipment.<sup>1</sup>

Ergonomics



Fire Equipment



Ventilation



HazMat Equipment



Training



Always remember to ensure strict compliance with all local applicable health and safety rules.

## Battery Safety

Improper disassembly can be dangerous—especially if individuals are unfamiliar with safety critical components, such as lithium ion batteries.

Discharge Battery



Do not inhale hazardous fumes



Do not damage battery



Be fully prepared for thermal runaway



### Other Battery Handling Tips

**Battery must be carefully handled, and can be dangerous when damaged.**

- Fully discharge device battery before attempting disassembly.
- Never bend, dent or puncture battery.
- Do not use tools that may accidentally damage battery.
- Store batteries in a safe environment to prevent inadvertent damage.
- Take care not to store large quantities of batteries together.
- Take care to prevent shorting of battery terminals.
- If a battery begins to vent or a thermal runaway occurs, immediately cover in sand or use gloves and tongs to place battery in a fire safe.

# Battery Transport and Storage Safety

Follow regulations and best practices for lithium-ion battery safety.

Here are some resources that may help recyclers.

## Topic

## Resource

### Damaged, Defective or Recalled (DDR) lithium cell batteries

Learn how to identify a lithium cell battery that may be swollen, damaged, defective or recalled. Follow all Department of Transportation guidelines.

This QR code links to a PDF file from the United States Department of Transportation entitled "Understanding the Risks of Damaged, Defective or Recalled (DDR) Lithium Batteries"

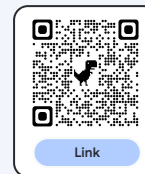

### Transporting Lithium Batteries

This QR code links to a webpage from the United States Department of Transportation entitled "Transporting Lithium Batteries"

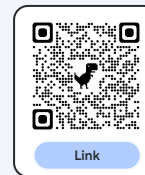

# Device Specific Warnings



## Caution

### Pixel 9a contains a class 1 laser module

The design of the device includes optics and protective housing to ensure that there's no access to a level of laser radiation above class 1 during normal use or approved servicing.

Use of controls or adjustments and performance of procedures except specified here may result in exposure to hazardous radiation.

# Pixel 9a: Expanded view

## Reuse indications

- Reusable without cleaning
- Reusable after cleaning
- Not reusable after disassembly

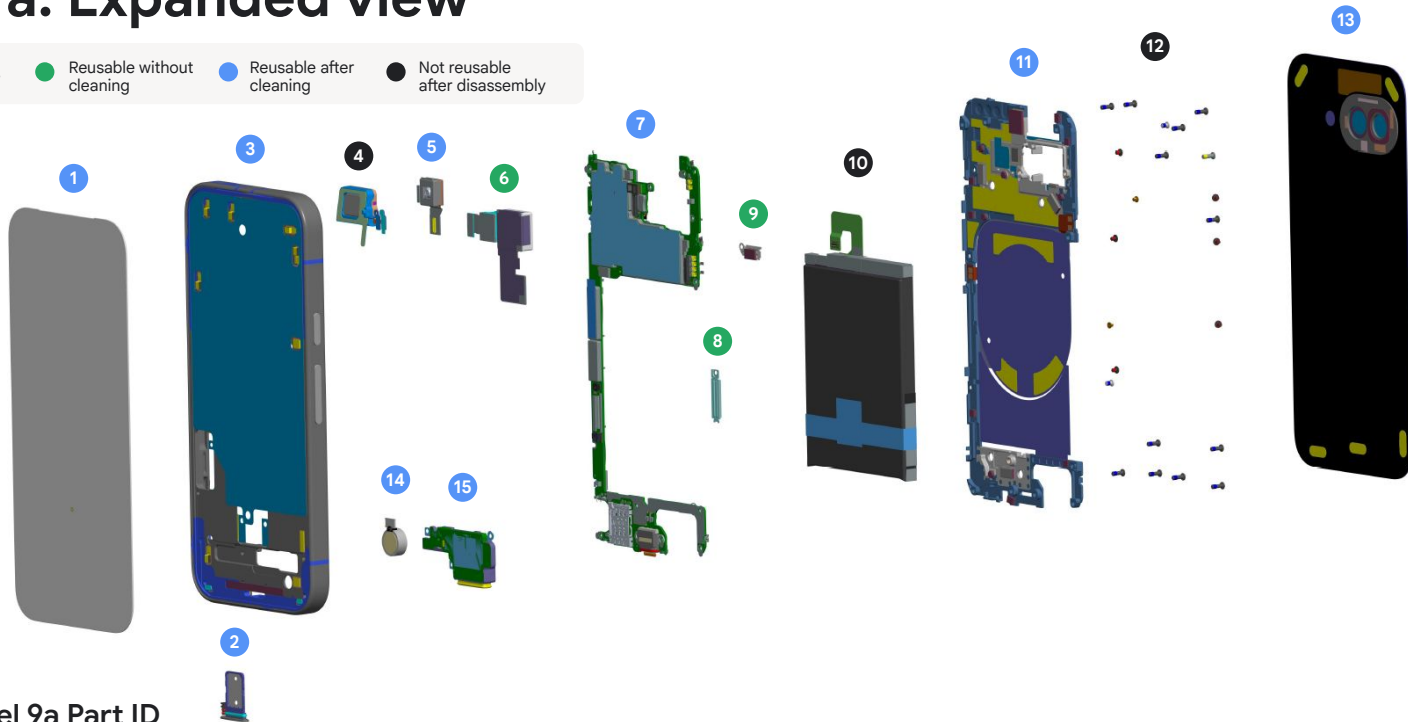

## Pixel 9a Part ID

1	<span style="color: blue;">●</span> Display	8	<span style="color: green;">●</span> Display B2B stamping plate	15	<span style="color: blue;">●</span> Bottom speaker
2	<span style="color: blue;">●</span> SIM tray	9	<span style="color: green;">●</span> Battery B2B stamping plate		
3	<span style="color: blue;">●</span> Enclosure	10	<span style="color: black;">●</span> Battery		
4	<span style="color: black;">●</span> Top speaker	11	<span style="color: blue;">●</span> Inner housing		
5	<span style="color: blue;">●</span> Front camera	12	<span style="color: black;">●</span> Screw		
6	<span style="color: green;">●</span> Wide and ultra wide rear camera	13	<span style="color: blue;">●</span> Back cover		
7	<span style="color: blue;">●</span> Logic board	14	<span style="color: blue;">●</span> Vibrator		

# Battery Location











There is one lithium-ion cobalt battery located in this device.

The approximate location of the battery is outlined.



# Screw map

These are the screws used in the Pixel 9a:

Screw G250-07426-00	Screw G250-07427-00	Screw G250-07428-00	Screw G250-07429-00	Screw G250-07430-00
				
				
Torx Plus 3IP	Torx Plus 3IP	Torx Plus 3IP	Torx Plus 3IP	Torx Plus 3IP

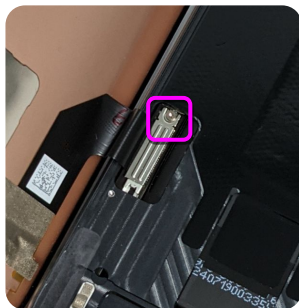

Display Bracket Screw  
(shown with display removed  
from front)

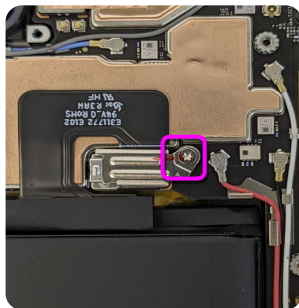

Battery Bracket Screw  
(shown with back)



Shown with Back Cover  
Removed



Shown with Back Cover and  
Inner Housing Removed

## What materials can be found in this device?

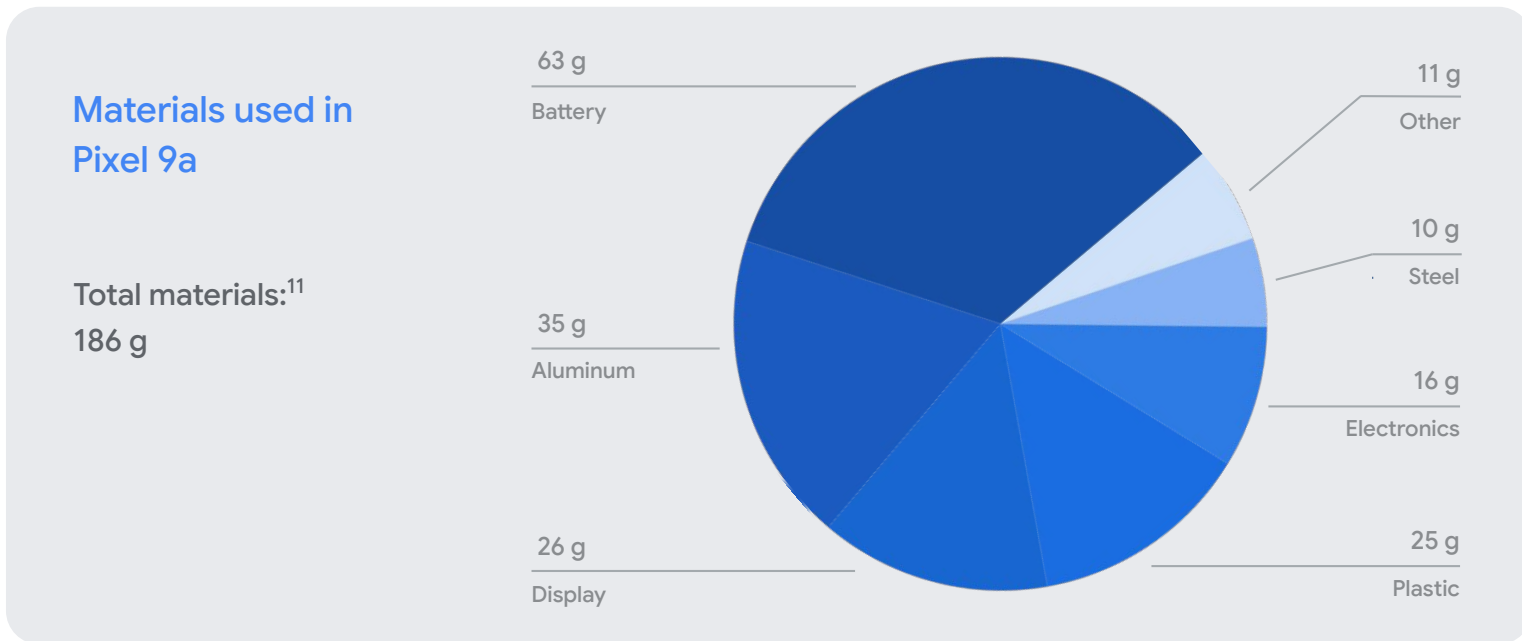

# What Tools Are Recommended to Disassemble This Device?

Flat Head Screwdriver



Prying Implement



Pliers



99.9% Isopropyl Alcohol



Torx IP 3 Driver



Universal disassembly shim or miniature pry tool



SIM Card Tray Ejector Pin



Heat Gun, Heat Pad or Heating Tools

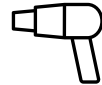

# 01

## Remove Charge Cable

Turn off device. Unplug charge cable and allow the device to drain battery charge.

### Target Recyclable Materials:

- Copper in Cable

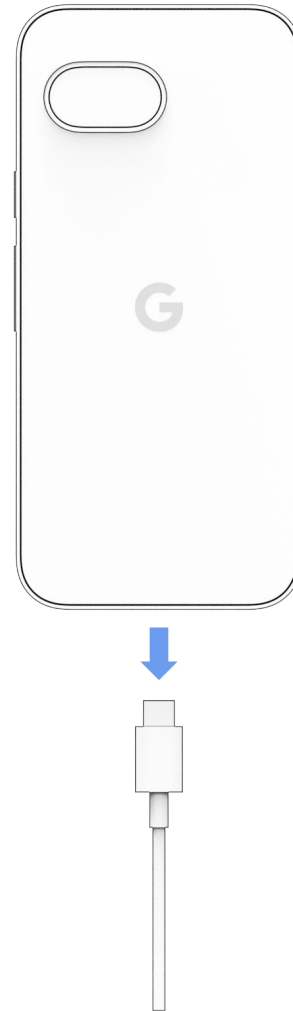

## 02

# Remove SIM Tray

Use Small Push Pin Ejector.

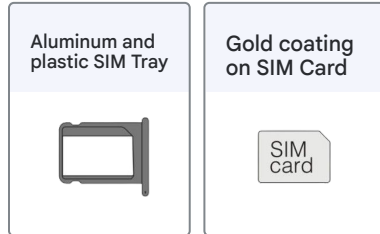

## 03

### Remove Back Cover

If possible, heat device to loosen adhesive. Use prying device with thin edge to lift back cover off of the enclosure.

**Target Recyclable Materials:**

- Aluminum Visor
- Back Glass



**Note**

Do not insert prying device too far into device as doing so may damage the battery.

# 04

## Remove Screws and Inner Housing

Use a Torx 3IP driver to remove the **16** screws that secure the inner housing to the enclosure.



## 05

### Remove Battery Connector Cover

- 1 Unfasten the screw to disconnect the battery stamping plate from the logic board.
- 2 Remove the metal plate from the logic board, and disconnect the battery flexible printed circuit.

**Target Recyclable Materials:**

- Steel



## 06

## Remove Battery

Although some recyclers may pry the battery out, we recommend first applying 99.9% isopropyl alcohol under the battery to compromise the adhesive.

Alternatively, a recycler could heat the adhesive under the battery to 158°F (70 °C) to weaken the adhesive bond. We recommend a duration of 10 minutes on the hot plate. Use caution. The heating plate is a hot surface and it could cause burns.

Battery must be recycled with specialized processes such as pyrometallurgy or hydrometallurgy.

### Target Recyclable Materials:

- Cobalt
- Lithium
- Nickel
- Copper
- Gold plating on connectors of flex cable

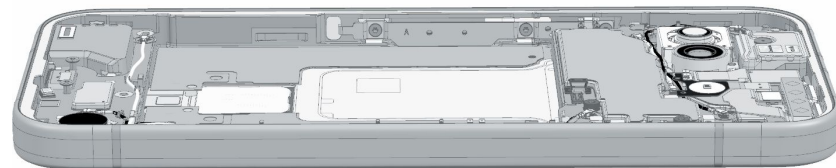

# 07

## Remove Main Logic Board Screws

Remove the four logic board screws.

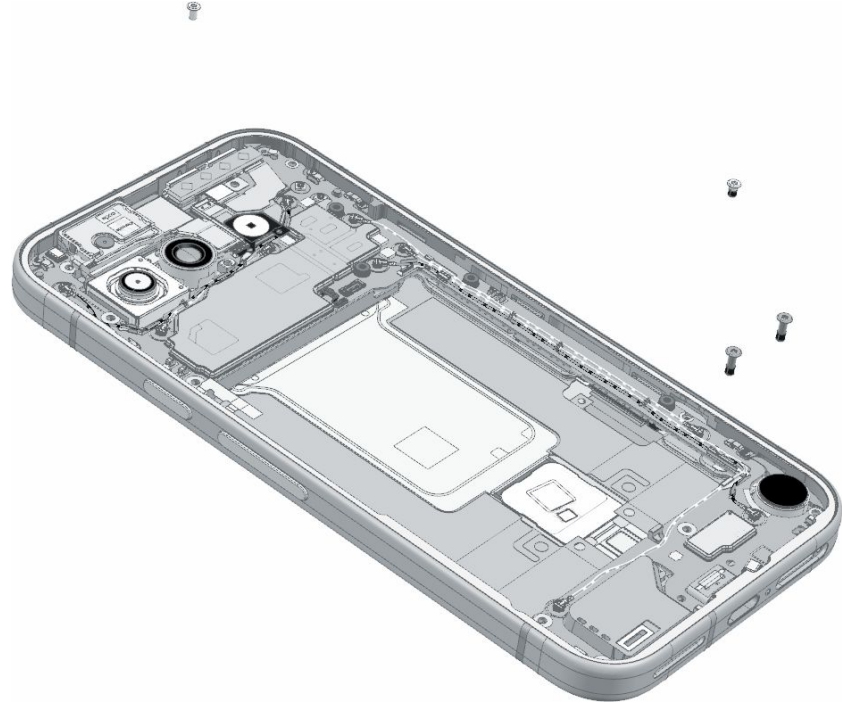

## 08

## Remove Main Logic Board

- 1 Lift Main Logic Board
- 2 If your recycling process is destructive, you can tear the display flex cable. Alternatively, you can use a screwdriver to remove the screw connecting the stamping plate and the logic board.

**Target Recyclable Materials:**

- SUS Rear Cam Backer
- Minimal Amount copper
- Minimal Amount Rare Earth Element in Front Cam Magnet
- Silicone
- Gold plating on flex cable Connector
- Neodymium (Rare Earth Element) Magnets in Wide Rear Cam

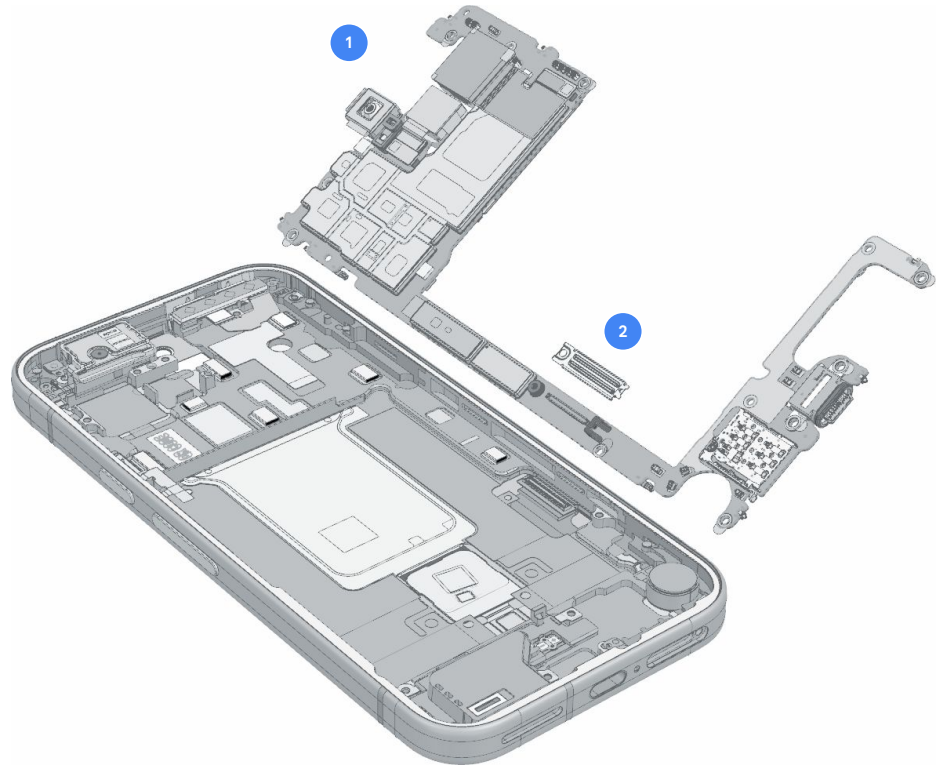

## 09

# Remove Front Camera and Back Camera from MLB

A recycler may wish to remove the front camera module from the main logic board.

Here the front camera module and rear cam module are highlighted.

### Target Recyclable Materials:

- SUS (sheet) Front Cam Backer
- Minimal Amount (0.06 g) Rare Earth Element in Front Cam Magnet
- Gold plating on flex cable Connector

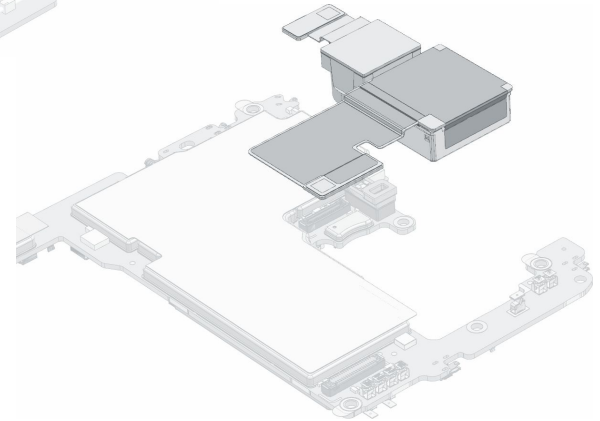
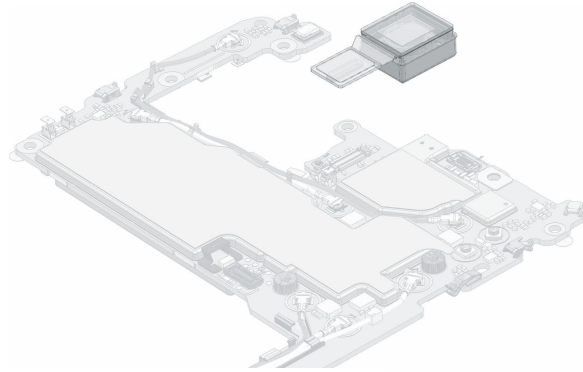

# 10

## Remove Bottom Speaker

Pry up the bottom speaker.

**Target Recyclable Materials:**

- Neodymium (Rare Earth Element) Magnets in Speaker
- Polycarbonate Casing
- Sheet Steel (internal)

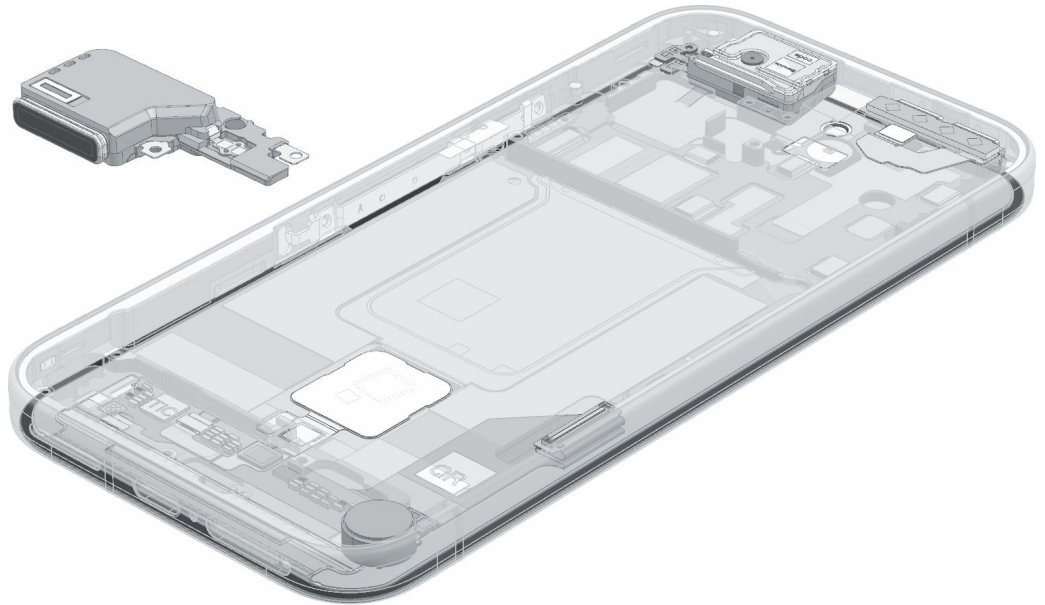

# 11

## Top Speaker

Use prying tool to lift up the top speaker.

**Target Recyclable Materials:**

- Neodymium (Rare Earth Element) Magnets in Speaker
- Steel Casing

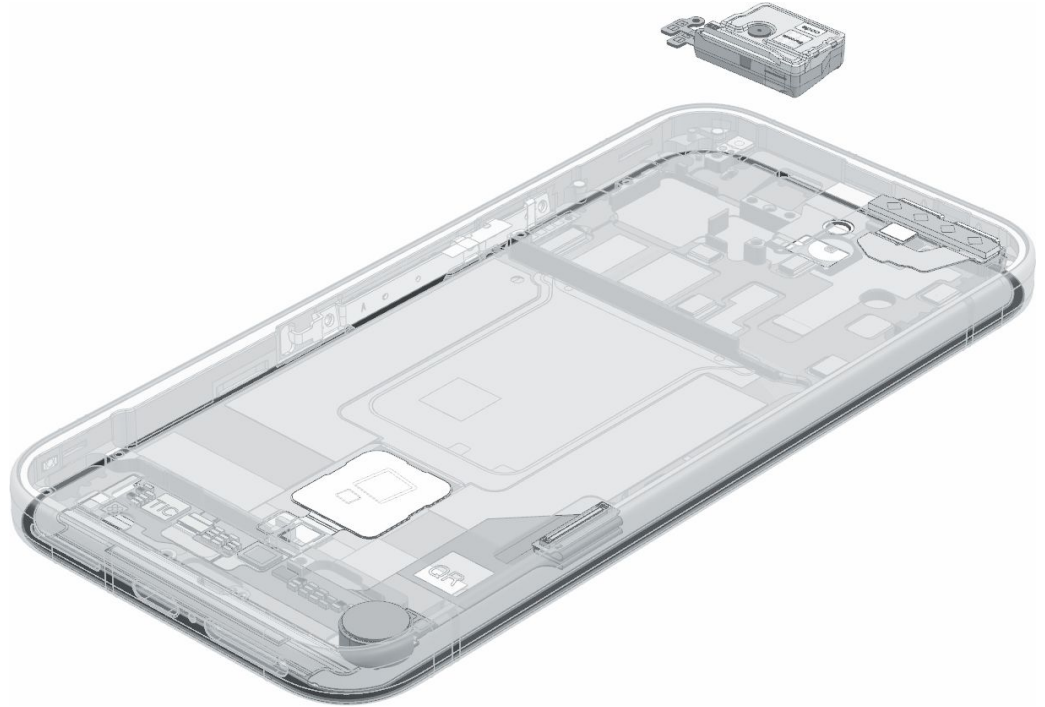

# 12

## Haptics / Vibrator

Use the prying tool to remove the haptics vibrator from the enclosure.

**Target Recyclable Materials:**

- Neodymium (Rare Earth Element) Magnets in Speaker
- Tungsten Alloy in vibrator mass
- SUS (sheet)
- Copper

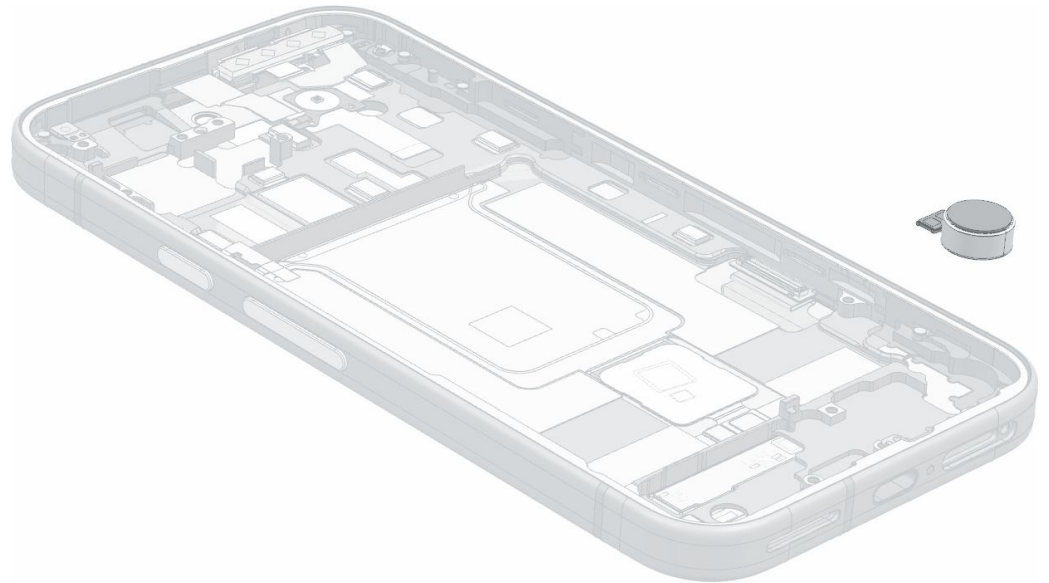

# 13

## Remove Display & Cover Glass

If possible, heat device to loosen adhesive. Use prying device with thin edge to lift back cover off of the enclosure.

The display also includes a number of flexible printed circuit boards, which can be pried off.

### Target Recyclable Materials:

- Glass
- Copper Film Backing
- Copper in Display Flex Cable
- Steel
- Gold plating on flex cable Connector



### Note

Wear protective gloves and safety glasses when handling damaged parts.

# Frequently Asked Questions

## Questions

**Is there information related to repair?**

## Answer

This recycling guide is for professional recyclers and is not intended in any way to serve as repair instructions.

For repair information or access to repair manuals, please visit:  
<https://store.google.com/magazine/repaircenter>

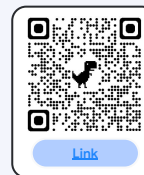

**Does Google offer spare parts to recyclers to refurbish or repair smartphones?**

This recycling guide is for recyclers and is not intended in any way to serve as instructions to test, refurbish or repair.

For access to Pixel spare parts, please visit:  
[https://www.ifixit.com/Parts/Google\\_Phone](https://www.ifixit.com/Parts/Google_Phone)

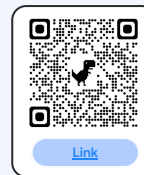

**How long does it take on average to recycle this device?**

Recycling times vary widely and depend on the how thoroughly the device is disassembled for material recovery and the specific tools and operational processes employed. To follow the steps in this guide, we estimate the device processing time will take approximately 1:30 - 5:00 minutes for a well-trained recycling technician.

**What hazards might there be when disassembling a device?**

The main hazards related to the end-of-life processing of this device are:

01. Damaging the battery in such a way that a thermal runaway occurs;
02. Broken glass causing cuts or abrasions;
03. Chemical inhalation—especially if thermal runaway occurs and
04. Exposure to the class 1 laser module