

SWIPBOX® INFINITY

TECHNICAL SPECIFICATION





ONE PLATFORM. INFINITE POSSIBILITIES.

SwipBox Infinity, SwipBox's flagship lean locker, communicates via Bluetooth, runs on a battery and is fully app operated from configuration to installation and parcel pickup. This lean version is ideal for markets that are digitally mature and carriers who are looking for a locker solution with minimum maintenance.

SwipBox Infinity Flex and SwipBox Infinity Connect build on the Infinity platform's lean-locker foundation. Both models are battery-powered and Bluetooth-enabled and may be fully app-operated.

Infinity Flex combines app control with a built-in PIN pad or screen interface, while Infinity Connect pairs app control with a standalone screen module for PIN code entry. This flexibility allows you to match each installation to user preferences and location needs without deploying multiple locker systems.

SWIPBOX INFINITY MODELS

14 COMPARTMENTS

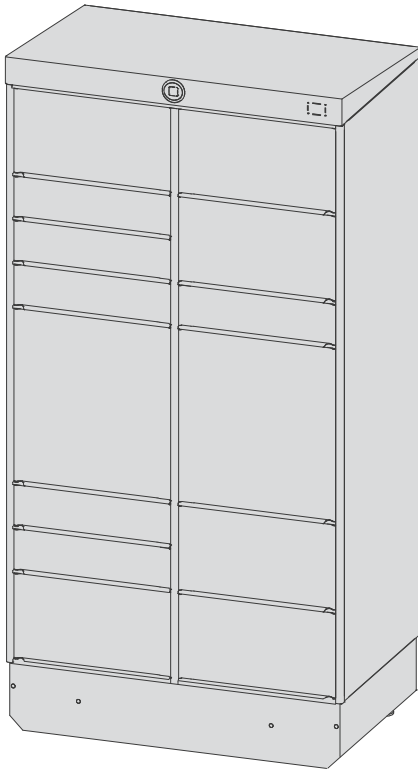

16 COMPARTMENTS

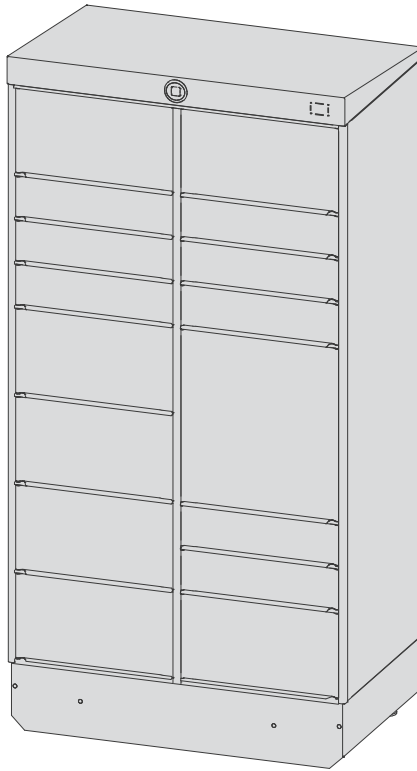

20 COMPARTMENTS

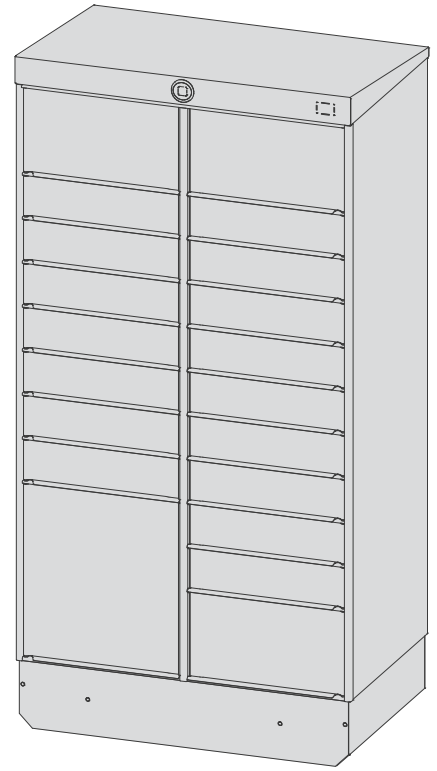

22 COMPARTMENTS

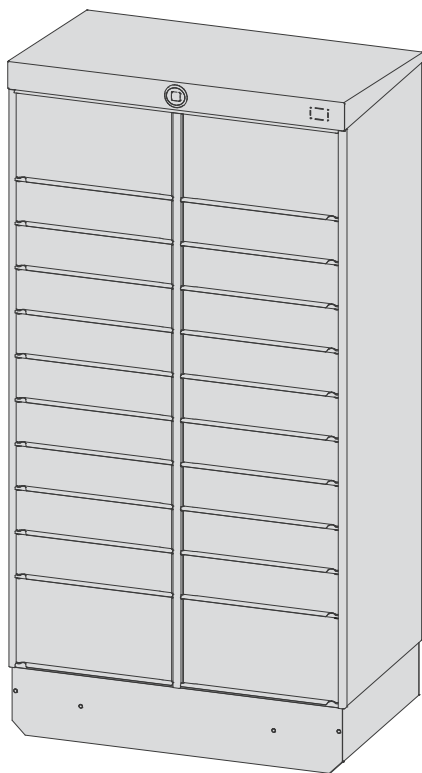

32 COMPARTMENTS

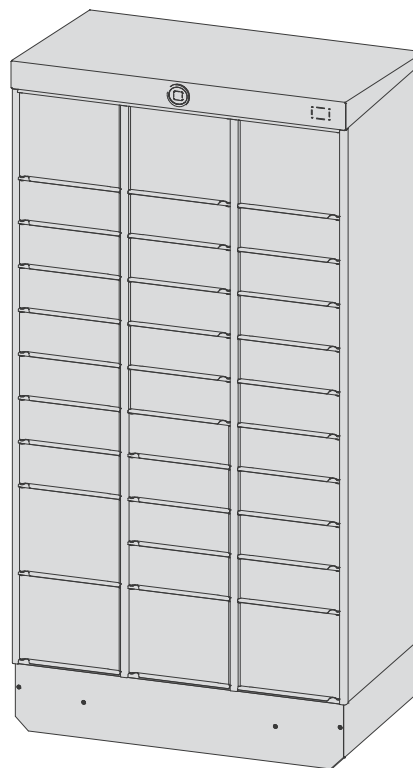

SWIPBOX INFINITY FLEX 10

28 COMPARTMENTS WITH A 10" SCREEN MODULE

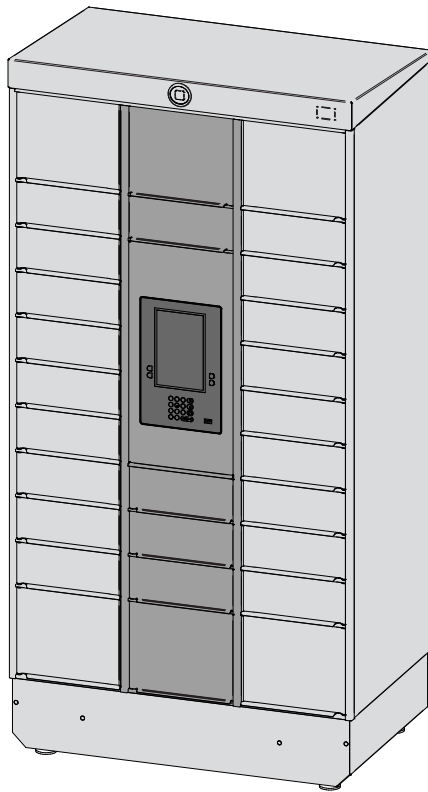

SWIPBOX INFINITY CONNECT 10

STANDALONE BUILT-IN 10" SCREEN MODULE

Combine with any Infinity model

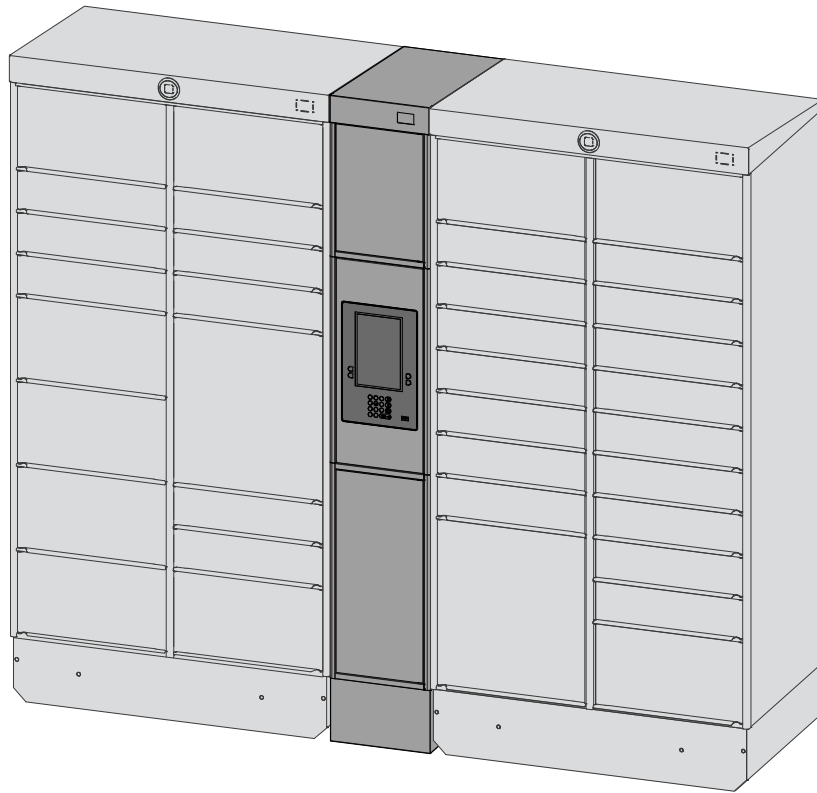
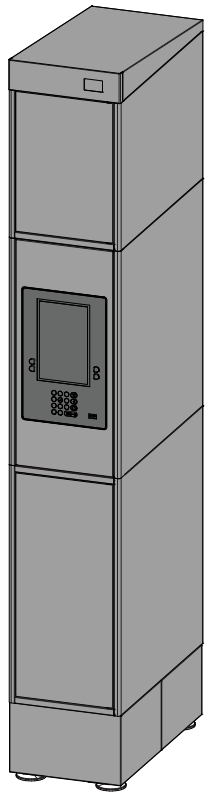

Sample setup

MEASUREMENTS AND WEIGHT

Indoor and outdoor models - Infinity and Infinity Flex

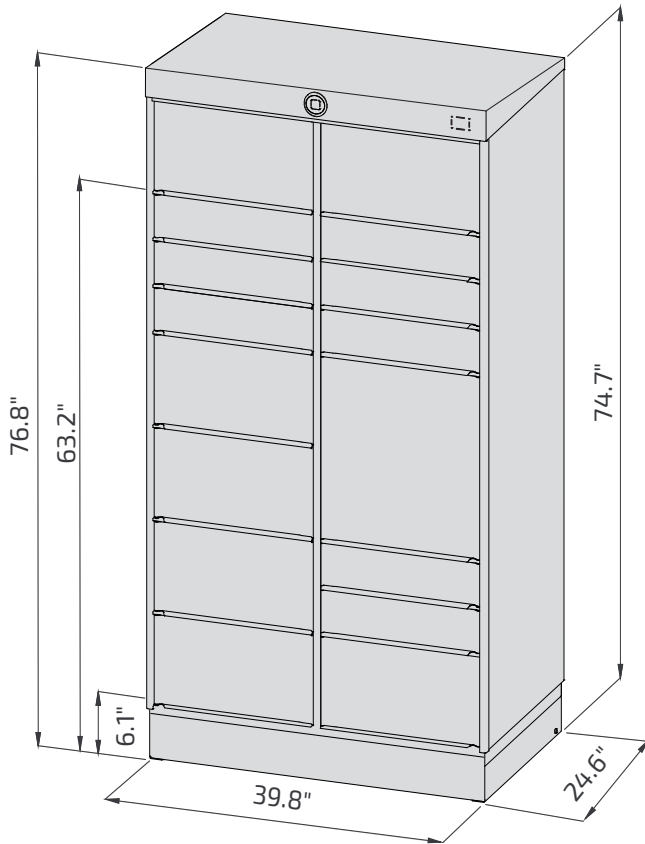

Outer dimensions are the same for all models

INDOOR

Weight

14 + 16 compartments	287lb
20 + 22 compartments	353lb
32 compartments	432lb

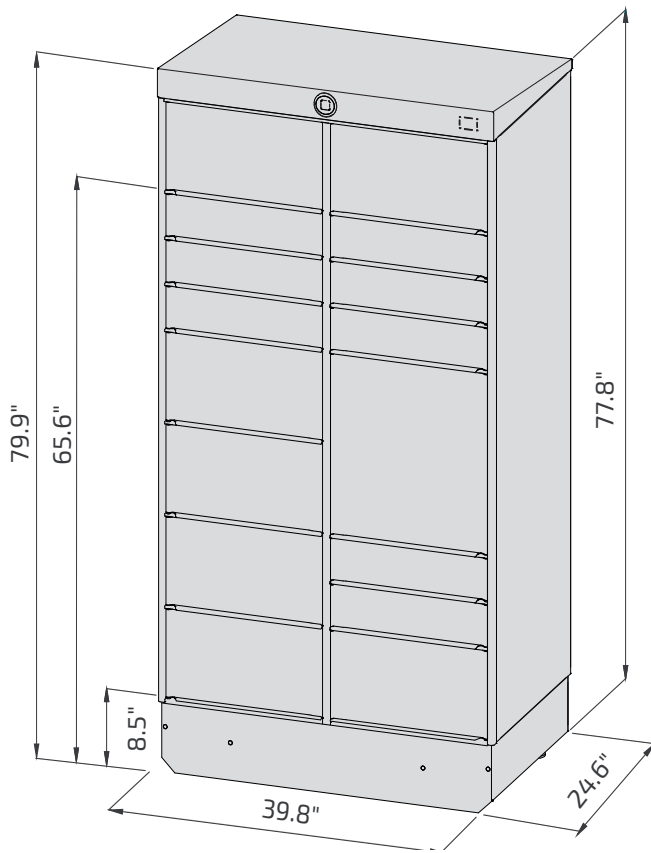

Outer dimensions are the same for all models

OUTDOOR

Weight

14 + 16 compartments	661lb
20 + 22 compartments	728lb
28 compartments*	807lb**
32 compartments	807lb

*Infinity Flex 10

**Additional battery weight 2x15,4lb



MEASUREMENTS AND WEIGHT

Outdoor model - Connect 10

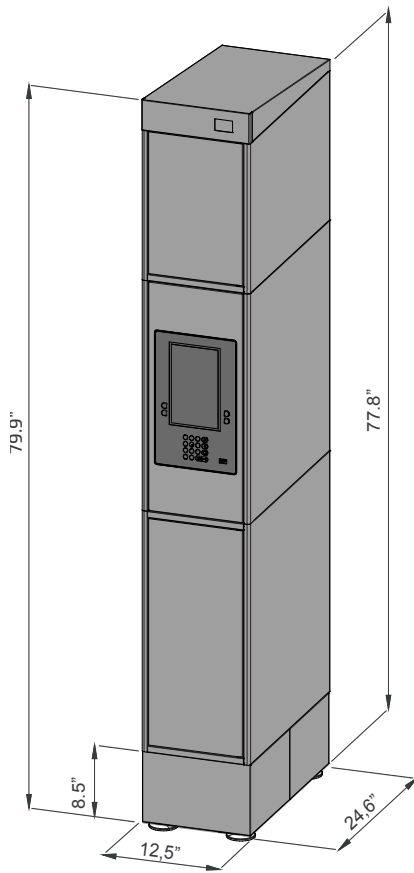

WEIGHT

Outdoor	165lb*
---------	--------

*Additional battery weight 2x15,4lb

COMPARTMENT SIZES

Measurements

	Small (HxWxD) 4.3x17.2x23in.	Medium (HxWxD) 9.4x17.2x23in.	Large (HxWxD) 19.7x17.2x23in.
14 compartments	6	6	2
16 compartments	8	7	1
20 compartments	16	3	1
22 compartments	18	4	-

	Small slim (HxWxD) 4.3x10.6x23in.	Medium slim (HxWxD) 9.4x10.6x23in.
32 compartments	25	7
28 compartments *	22	6

*Infinity Flex 10





TECHNICAL INFORMATION (INFINITY)

Materials and operational data

Power input	Battery operated. Min. lifespan of 10 years
Bluetooth® communication range	10ft from the parcel locker
Storage/transport temp.	-4°F to 122°F
Operating temp.	-4°F to 122°F
Operating humidity max.	95% (non-condensing)
Max. weight on shelf	70lb
Paint	Powder coating
Material	Aluminum and galvanized sheet metal

SWIPBOX INFINITY FLEX PIN

14 COMPARTMENTS

16 COMPARTMENTS

20 COMPARTMENTS



Wheelchair accessibility: All interactive elements are placed at a height between 14.9"–48.0" as dictated by the EN-301 549 standard.

22 COMPARTMENTS



32 COMPARTMENTS



TECHNICAL INFORMATION (PIN PAD)

Materials and operational data

Power input	Battery operated. Lifespan of 5 years*
Storage/transport temp.	-4°F to 122°F
Operating temp.	-4°F to 122°F
Operating humidity max.	95% (non-condensing)
Material	Plastic
Max. view angle (display)	80 degrees
Button backlight	Yes
Modem	LTE-M modem w. nano SIM card

*Based on standard firmware with 4 periodic synchronisations and 24 transactions per day. Battery lifetime will depend on usage pattern, firmware configuration and connectivity.

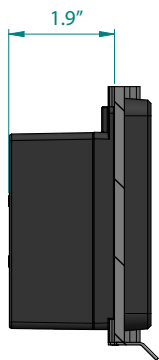
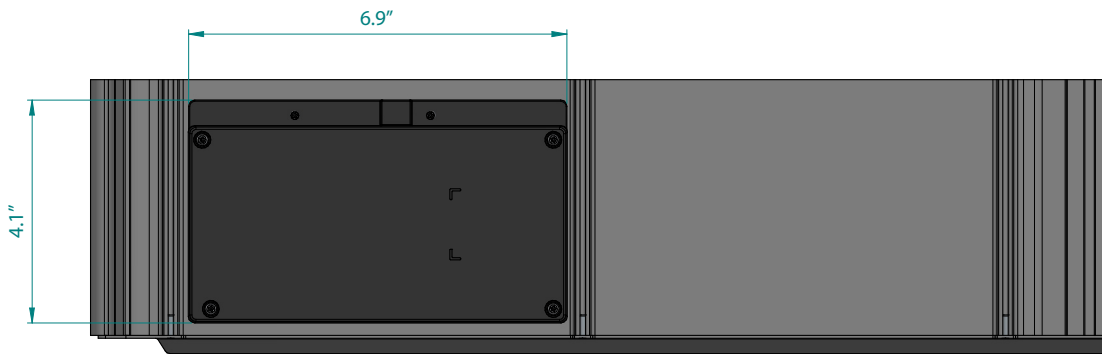
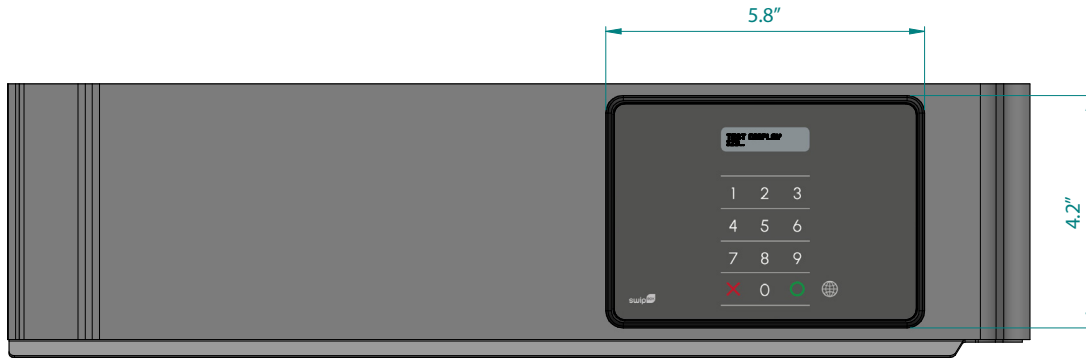

TECHNICAL INFORMATION (SCREEN SECTION)

Materials and operational data

SCREEN MODULE

Power input	Battery operated. Min. lifespan of 2 years*
Storage/transport temp.	-4°F to 122°F
Operating temp.	-4°F to 122°F
Operating humidity max.	95% (non-condensing)
Screen resolution	1280px x 800px
Viewing angle	Free
Button backlight	Yes
Modem	LTE Cat-1 bis modem w. nano SIM card and SoftSIM capabilities
Loudspeaker	Built in
Scanner	Built in
NFC	Prepared for NFC functionality

*Battery lifetime will depend on usage pattern.

SCREEN CABINET

Material	Galvanised sheet metal, powder coated
----------	---------------------------------------

Match your customers' needs. Today's customers expect fast delivery and flexible pickup options. Infinity offers multiple interface choices – app, PIN pad or screen – so you can select the solution that fits your users.

Adapt your network with ease. From small parcels to mixed sizes, Infinity models fit your operation. Fast installation means you can scale, relocate or respond quickly to changing customer needs.

Keep costs low with a lean design. Infinity's ultra-low energy consumption means that over 10 years, it uses the equivalent of a hairdryer running for just 7 minutes. A minimal mechanical design reduces maintenance needs, repair costs, and part replacements, helping you lower both operational expenses and environmental impact.



SwipBox International A/S

Ellegaardvej 7

DK-6400 Sonderborg

international@swipbox.com

www.swipbox.com

Version 2 2025